



LUND UNIVERSITY

CFD Modeling of A Large Complex Fire

Yan, Zhenghua

2000

[Link to publication](#)

Citation for published version (APA):

Yan, Z. (2000). *CFD Modeling of A Large Complex Fire*. (LUTVDG/TVBB--3120--SE; Vol. 3120). [Publisher information missing].

Total number of authors:

1

General rights

Unless other specific re-use rights are stated the following general rights apply:

Copyright and moral rights for the publications made accessible in the public portal are retained by the authors and/or other copyright owners and it is a condition of accessing publications that users recognise and abide by the legal requirements associated with these rights.

- Users may download and print one copy of any publication from the public portal for the purpose of private study or research.
- You may not further distribute the material or use it for any profit-making activity or commercial gain
- You may freely distribute the URL identifying the publication in the public portal

Read more about Creative commons licenses: <https://creativecommons.org/licenses/>

Take down policy

If you believe that this document breaches copyright please contact us providing details, and we will remove access to the work immediately and investigate your claim.

LUND UNIVERSITY

PO Box 117
221 00 Lund
+46 46-222 00 00

CFD Modeling of A Large Complex Fire

Zhenghua Yan

**Department of Fire Safety Engineering
Lund University, Sweden**

Report 3120, Lund 2000

Zhenghua Yan

Report 3120
ISRN: LUTVDG/TVBB--3120--SE

Number of pages: 21
Illustrations: Zhenghua Yan

Abstract

Numerical simulation of turbulent combustion and flame spread in a large complex fire has been carried out using a self-developed CFD code SMAFS to investigate the well-known Göteborg fire accident [1]. This comprehensive computation includes modeling of turbulence, turbulent combustion, sooting, radiation, heat conduction and pyrolysis of solid fuel. In order to reduce the wall clock time to an acceptable limit, the computation was parallelized based on domain and angle decompositions and performed using 8 processors on a SGI Origin 2000 super computer. The results, including the transient development of the smoke profile, heat flux distribution and flame spread over combustible material, etc., are presented and analyzed. It is found the simulation is in a good agreement with the real fire accident observation and helps explain the real fire phenomena.

© Copyright: **Department of Fire Safety Engineering, Lund University, Sweden, 2000**

CFD Modeling of A Large Complex Fire

YAN Z. H.

*Fire Safety Engineering Dept.
Lund University, Box 118
S-22100, Lund, Sweden*

ABSTRACT

Numerical simulation of turbulent combustion and flame spread in a large complex fire has been carried out using a self-developed CFD code SMAFS to investigate the well-known Göteborg fire accident [1]. This comprehensive computation includes modeling of turbulence, turbulent combustion, sooting, radiation, heat conduction and pyrolysis of solid fuel. In order to reduce the wall clock time to an acceptable limit, the computation was parallelized based on domain and angle decompositions and performed using 8 processors on a SGI Origin 2000 super computer. The results, including the transient development of the smoke profile, heat flux distribution and flame spread over combustible material, etc., are presented and analyzed. It is found the simulation is in a good agreement with the real fire accident observation and helps explain the real fire phenomena.

CASE DESCRIPTION

One-fourth Scale Simulation

Both one-fourth and full scales simulations were carried out. In the one-fourth scale simulation, the scenario was constructed largely based on the one-fourth experiment performed at SP [1], with some differences which are believed unimportant (except the heat release history) as far as the simulation is concerned. Figure 1 shows different views of the considered building. Initially, all the windows and doors were closed except the exit door at the stairwell (see Fig. 1(a)) and the backside door (see Fig 1(b)). Fire started at the stairwell and then penetrated into the dance hall through the connecting doorway, which was opened at 6 minutes after the fire started. Two and half more minutes later, several heated windows (marked by the green color in Fig. 1(d)) were assumed broken. It would be worth to note that the procedure of opening the door and windows is not exactly the same as that in the SP's experiment. Due to the strong oscillation and uncertainty of the experimental heat release curve, it is extremely difficult, if not impossible, to follow the actual heat release in the numerical modeling. Therefore, a modeled heat release history was used in the simulation instead, as shown in Fig. 2. The difference between the modeled and the actual heat release histories makes the comparison between computation and measurement rather groundless. With the growth of fire, the area of the fire source was modeled to expand until it reached the same area of wood crib used in the experiment [1].

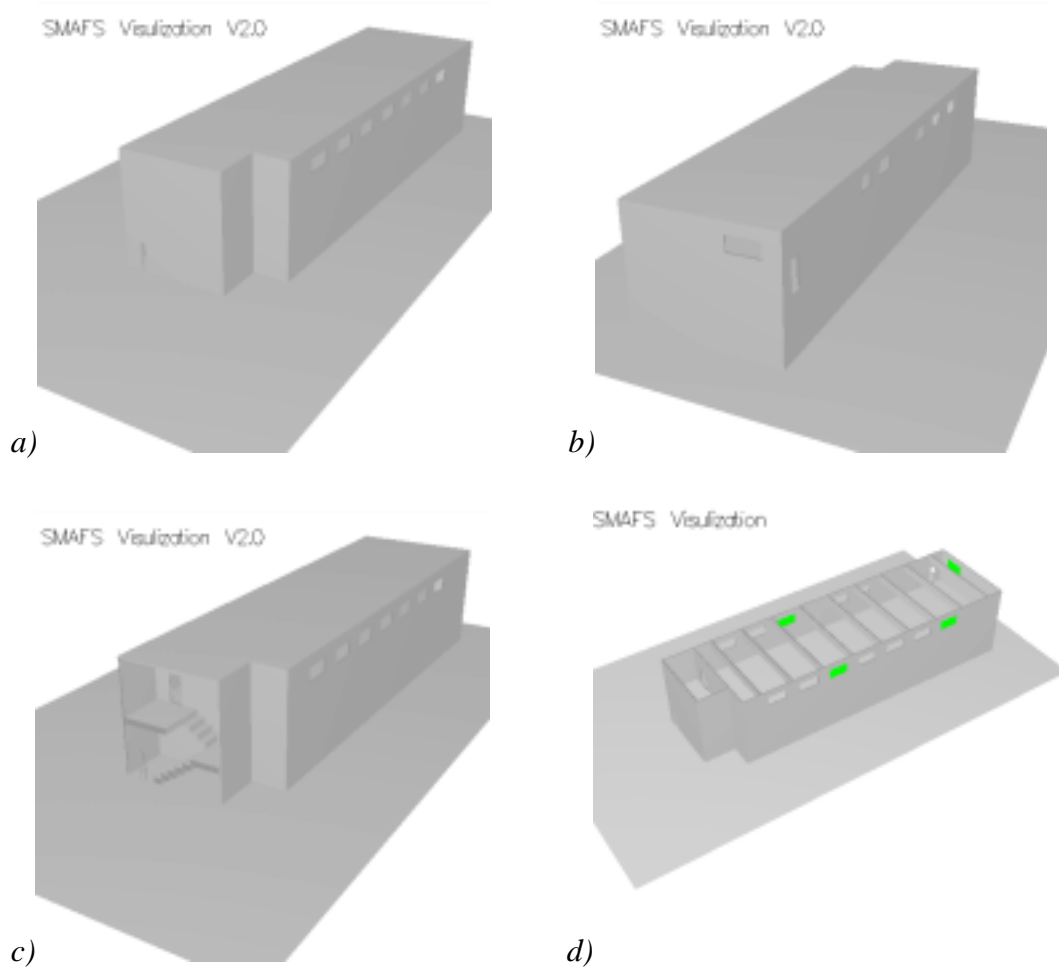

Fig. 1 Different views of the one-fourth scale building

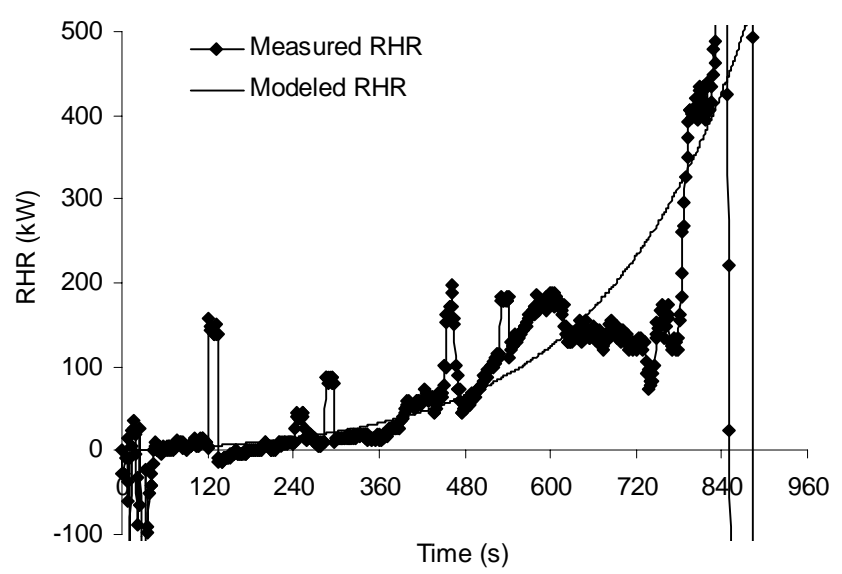

Figure 2 Heat release histories in the one-fourth scale fire

Full Scale Simulation

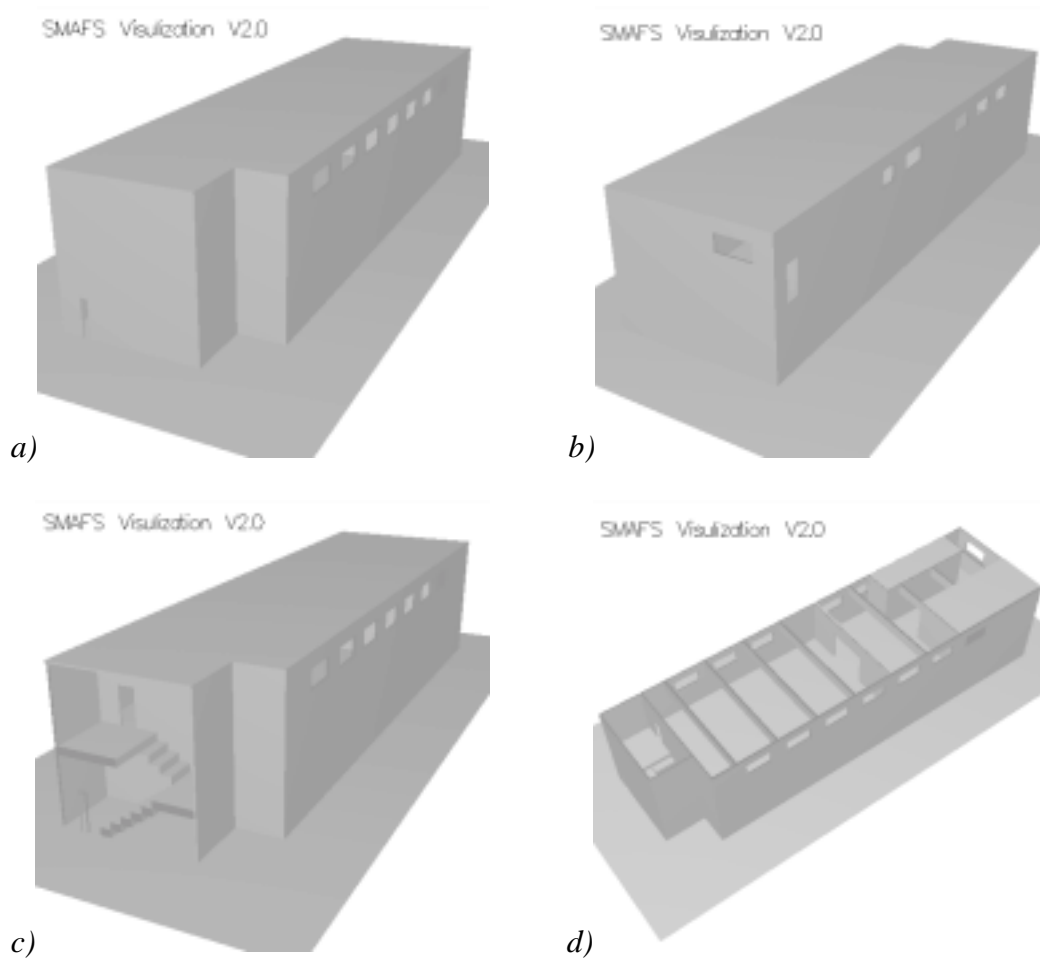

Fig. 3 Different views of the full scale building

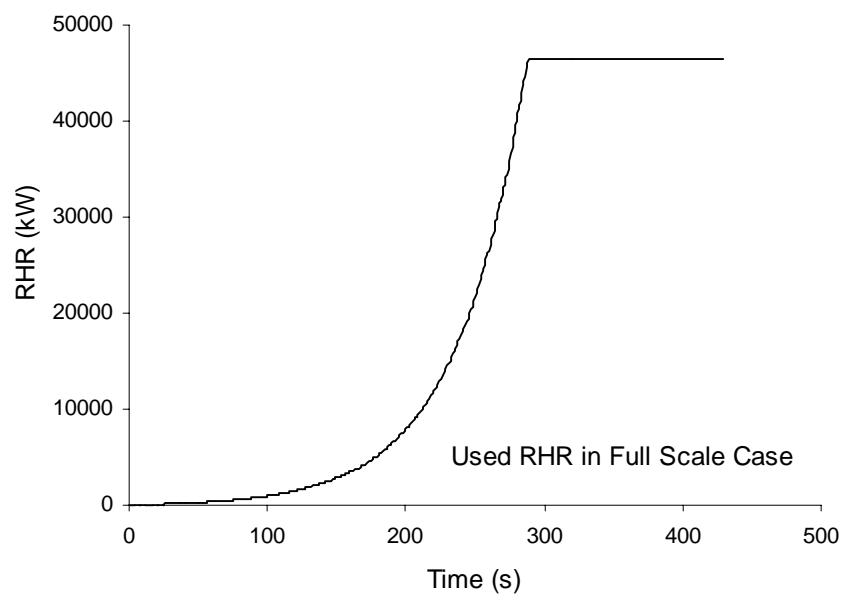

Figure 4 Heat release history used in the full scale fire simulation

The full-scale building came from the scaling of the one-fourth scale building by a factor of 4 in all three spatial dimensions and has a slightly different internal structure as shown in Fig. 3. Fire also started at the stairwell and then penetrated into the dance hall through the connecting doorway, which was opened during the fire. Since the object is to capture the major features of the fire accident, to reduce the computing labor to a reasonable limit, the whole fire process was somehow compressed on the time coordinate. As a result, the start fire was assumed to grow quicker than in the one-fourth scale case. Fig. 4 shows the start fire heat release history used in the computation. This used heat release history is based on a simple scaling of the heat release of the one-fourth scale fire by a factor of $16\sqrt{2}$, but with time coordinate compressed. The connecting door and all the windows were opened respectively at 3.5 and 4.5 minutes after fire started.

In this full scale simulation, as indicated by the wood color in Fig. 5, the side walls of the connecting doorway and the floor in the large dance hall were set combustible as they were in reality, although they were assumed to be particle board in material. The investigation was then made in the computation to study the possible flame spread.

In both simulations, the fuel in the starting fire was assumed to be propane.

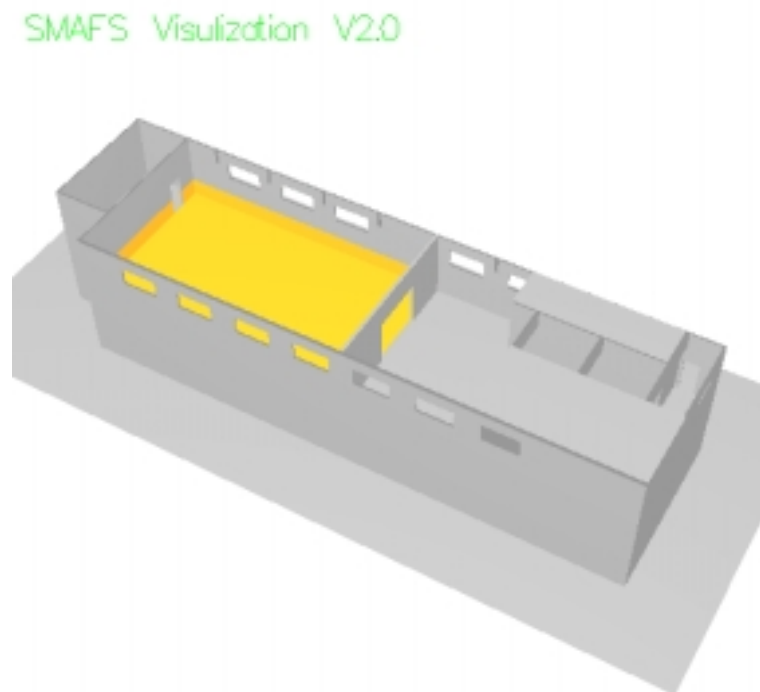

Fig. 5 Internal combustible floor and walls of the building

NUMERICAL COMPUTATION

Comprehensive computations were carried out to study the fire process, using about half million gas phase nodes, half million solid phase nodes, 16 radiation rays, and time steps varying from 0.25 to 2.0 seconds. Considering the physical difference of the processes in the gas and solid phases, two separate grids were adopted so that both

phases could be properly and economically resolved. The used gas phase grid for the full scale is illustrated in Fig. 6. The models activated in these two applied computations are: the standard buoyancy-modified $k - \varepsilon$ two-equation turbulence model [2], eddy dissipation turbulent combustion model [3], discrete transfer radiation model [4], an integral radiation property evaluation model [5], a simple empirical soot model and solid fuel pyrolysis model [6].

In order to reduce the wall clock time, the computation was run in parallel using 8 processors on the SGI Origin 2000 super computer named Embla in Lund University, Sweden. The parallelization was based on domain and angle decompositions.

SMAFS Visualization

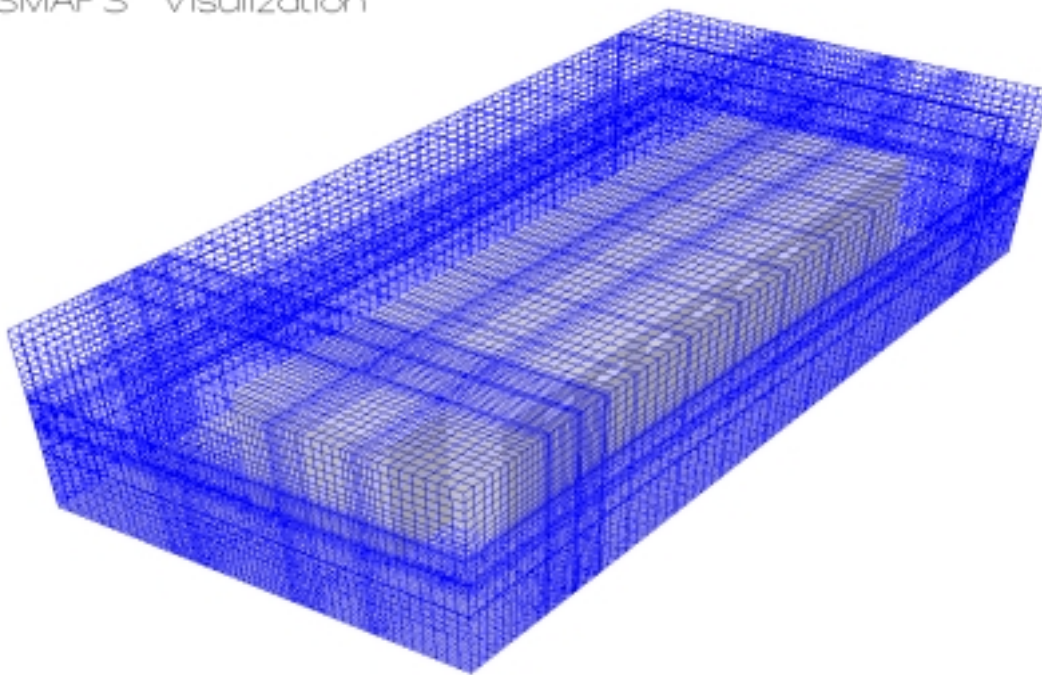

Fig. 6 Gas phase grid for full scale simulation

INITIAL AND BOUNDARY CONDITIONS

The whole system was assumed to stand initially still in an environment of uniform temperature of $300K$. The solid boundaries, including the wall surface and the floor, were assumed to be non-slip boundaries. As an approximation, the standard wall function treatment was used to calculate the convection heat transfer.

The computation domain was extended to the region where the free boundary condition was employed.

RESULTS AND DISCUSSIONS

One-fourth Scale Simulation

As mentioned earlier in the case description, due to practical difficulties, the simulation's setup did not map exactly with that of the referred experiment and consequently the comparison between the computation and measurement is not well grounded. As a result, the results of the one-fourth scale simulation shown below are only for reference although they are presented together with the available measurements.

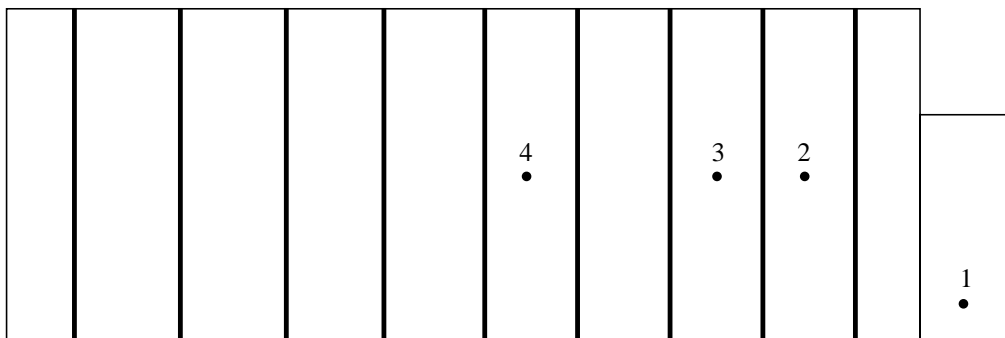

Fig. 7 Horizontal locations of four particular measurement points

Figure 7 shows horizontal positions of four particular temperature measurement points of the SP's experiment. Among these four points, point 1 was at 0.6 m above the upper floor of the stairwell and the other points were at 0.09 m below the ceiling. The predicted and measured transient temperature profiles of these four points are shown in Figs. 8-11.

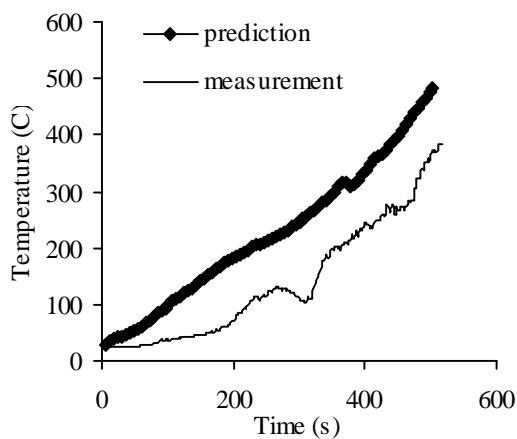

Fig. 8 Temperature vs time (point 1)

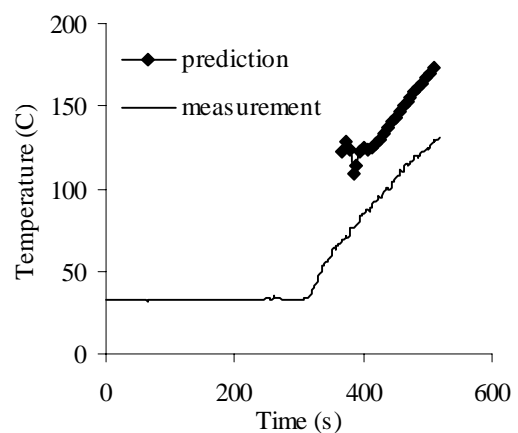

Fig. 9 Temperature vs time (point 2)

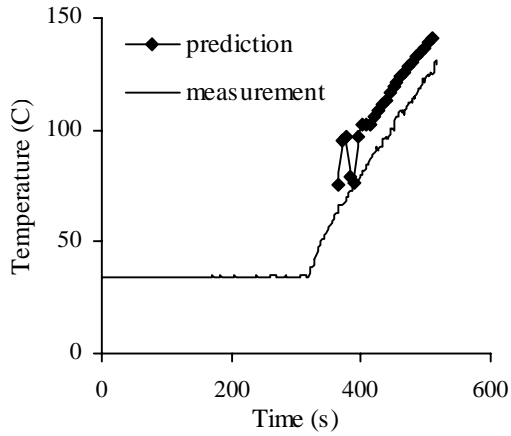

Fig. 10 Temperature vs time (point 3)

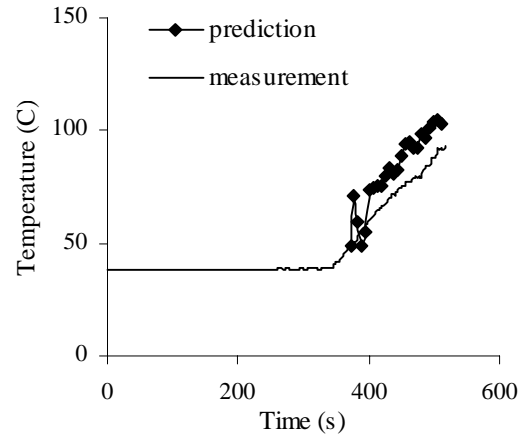
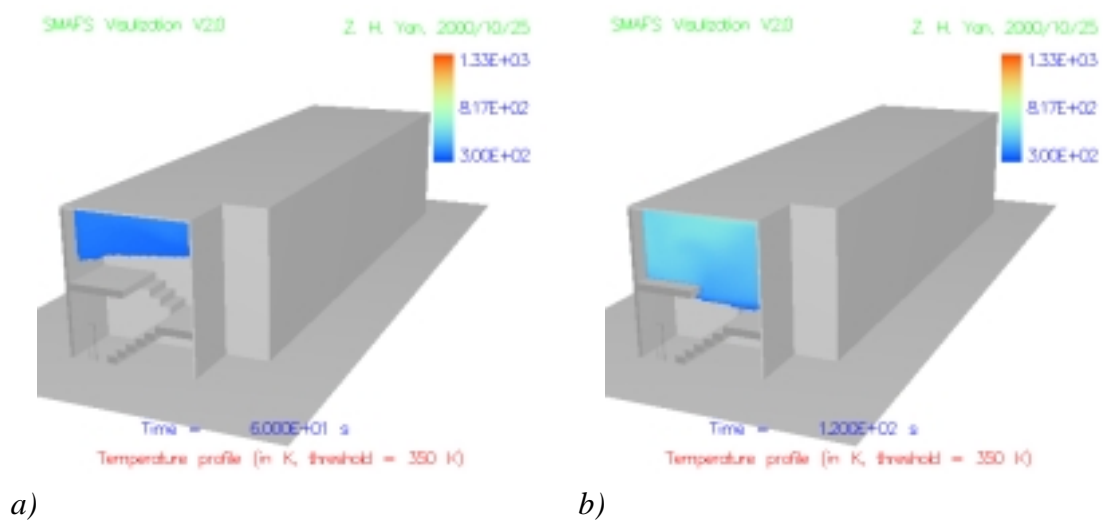

Fig. 11 Temperature vs time (point 4)

Full Scale Simulation

Figure 12 shows the predicted transient developing of an example temperature profile in the stairwell where the fire started. As can be seen, at the early stage, the hot gas filling was fast and gradually slowed down latter when the fire became ventilation controlled. After the door connecting the stairwell and dance hall was opened, due to the large leakage of the hot gas from the stairwell to the dance hall, the height of the hot gas layer in the stairwell reduced somewhat and then remained essentially stablized. The temperature profile shown in this figure also indicates that at late stage when the fire in the stairwell became ventilation controlled, the combustion mainly happened at place close to stairwell doorway where fuel could meet oxygen in stead of directly at fuel source. Due to the limited ventilation and quick growth of fuel release, oxygen supplied through the stairwell doorway was consumed well before it could reach the fuel source center.



a)

b)

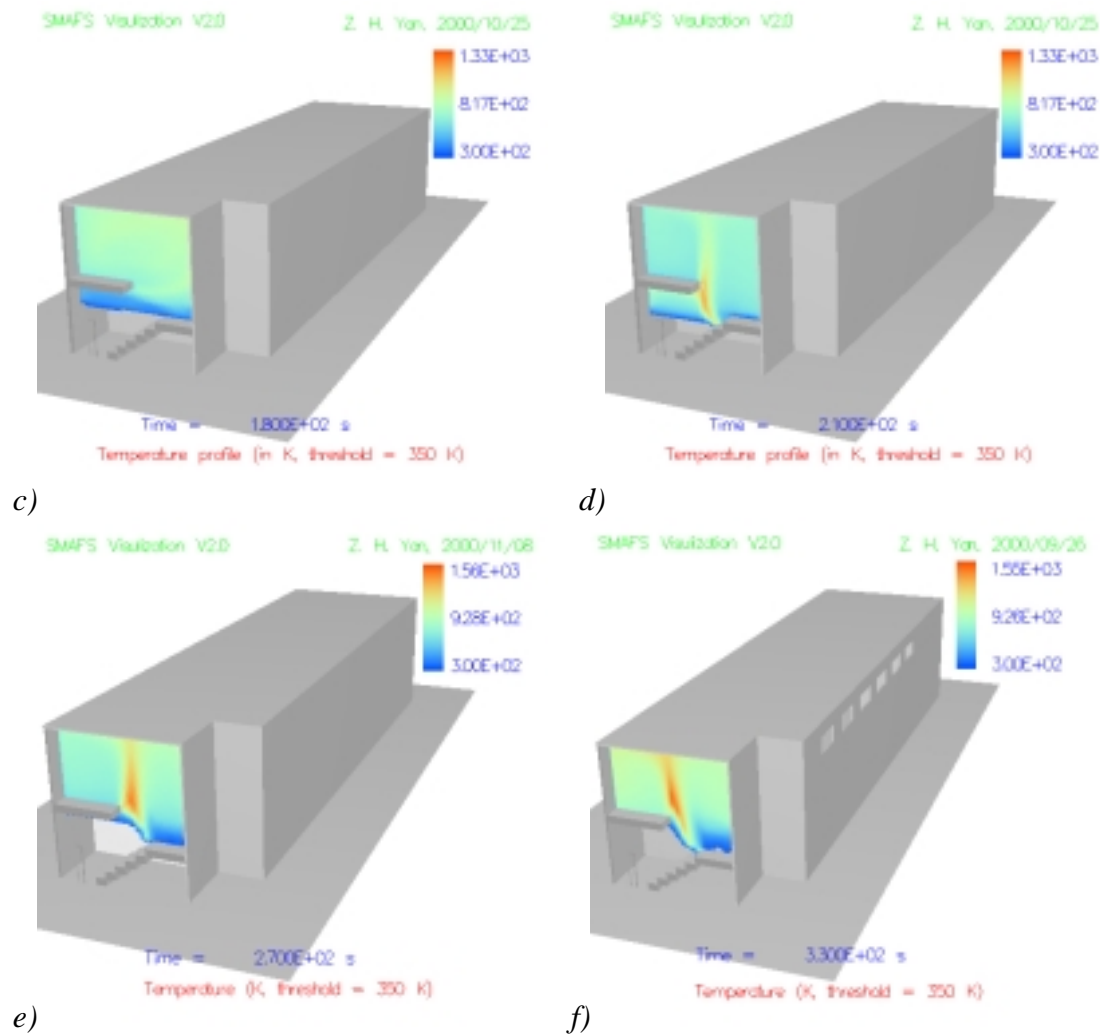
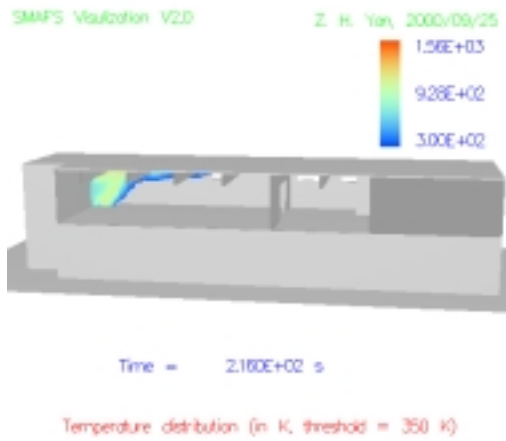
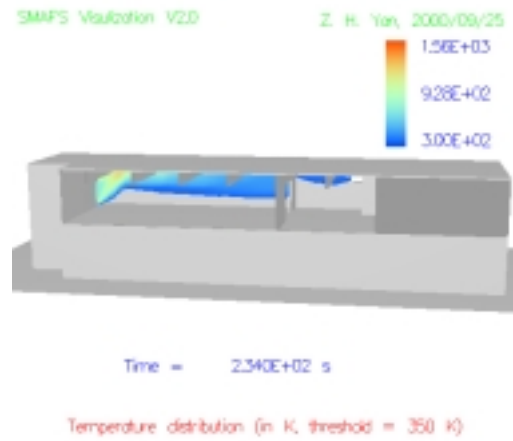

Fig. 12 Predicted transient developing of an example temperature profile in stairwell

Due to the quick growth in fuel release of the fire source and the limited ventilation, the combustion in the stairwell was incomplete and a large amount of fuel was accumulated. Once the connecting door is open, the accumulated hot fuel went into the dance hall through the connecting doorway and mixed there with oxygen. As a result, fire penetrated into the dance hall. A typical temperature profile sequence in the dance hall after the connecting door was opened is shown in Fig. 13. This sequence presents clearly the hot gas filling process and the shift of the flame front (indicated by the high temperature) from the connecting door to the back of the dance hall. After the windows were opened (at time = 270 s), the flow field changed accordingly in such a way that the back part of the dance hall was partly cleared by the fresh air sucked in from the backside door (compare Fig. 13 (d) with Figs. 13(e-f)). This phenomenon will be discussed in more detail later when the flow field is presented. In order to give a direct representation of the flame front, a plot of the fuel consumption rate is presented in Fig. 14.



a)



b)

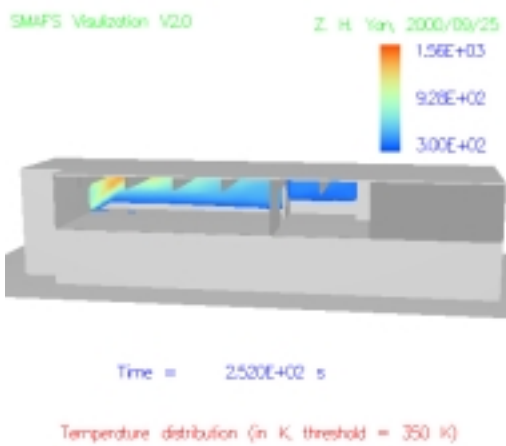

c)

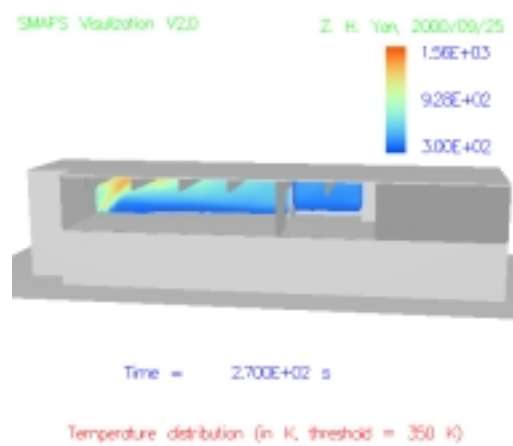

d)

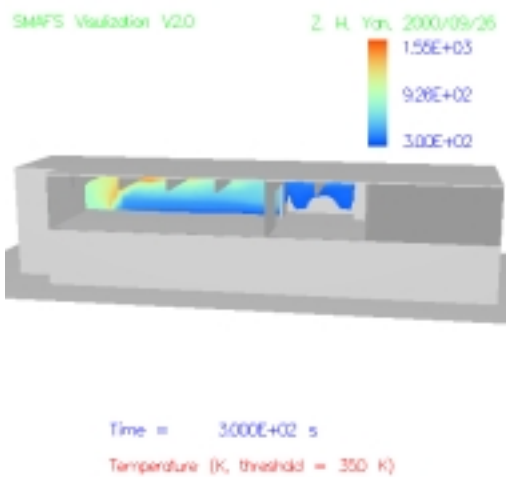

e)

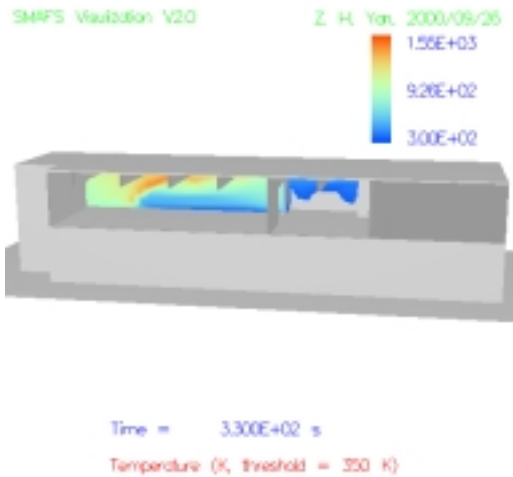

f)

Fig. 13 Predicted transient developing of an example temperature profile in dance hall

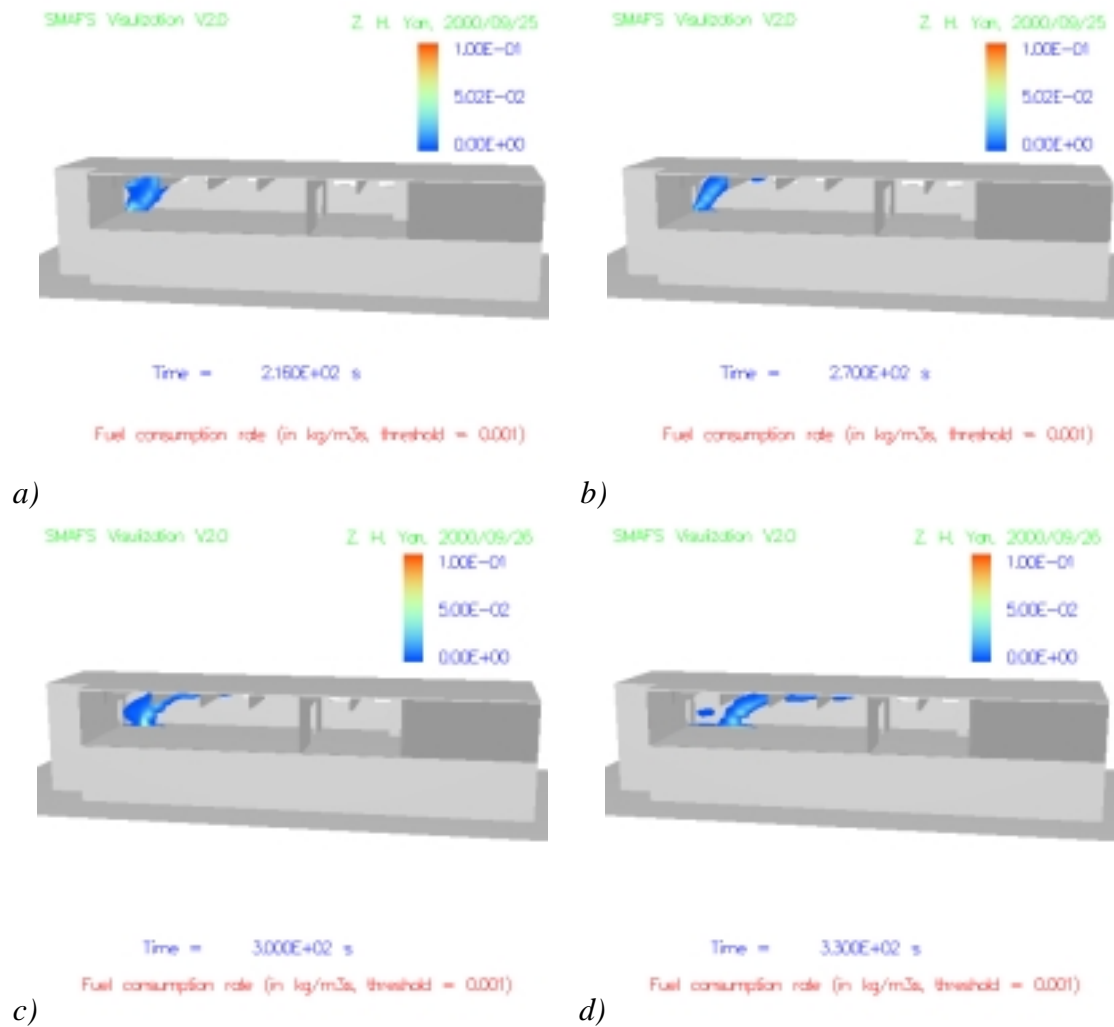

Fig. 14 Predicted fuel consumption rate in dance hall

The big flame in the dance hall imposed an intensive heating to its surrounding and presented a substantial potential of flame spread over combustible materials. Figure 15 shows the predicted net radiation flux distribution in the dance hall. Due to the strong heating, the combustible side walls and floor were ignited and flame spread over, as shown in Fig 16, where the predicted transient developing of the char layer on the combustible side walls and floor is presented. The ignition of solid combustible material could produce quite amount of smoke and toxic gases and thus increase the severity of the fire accident. It would be worth to mention that flame spread was also observed in the real fire accident.

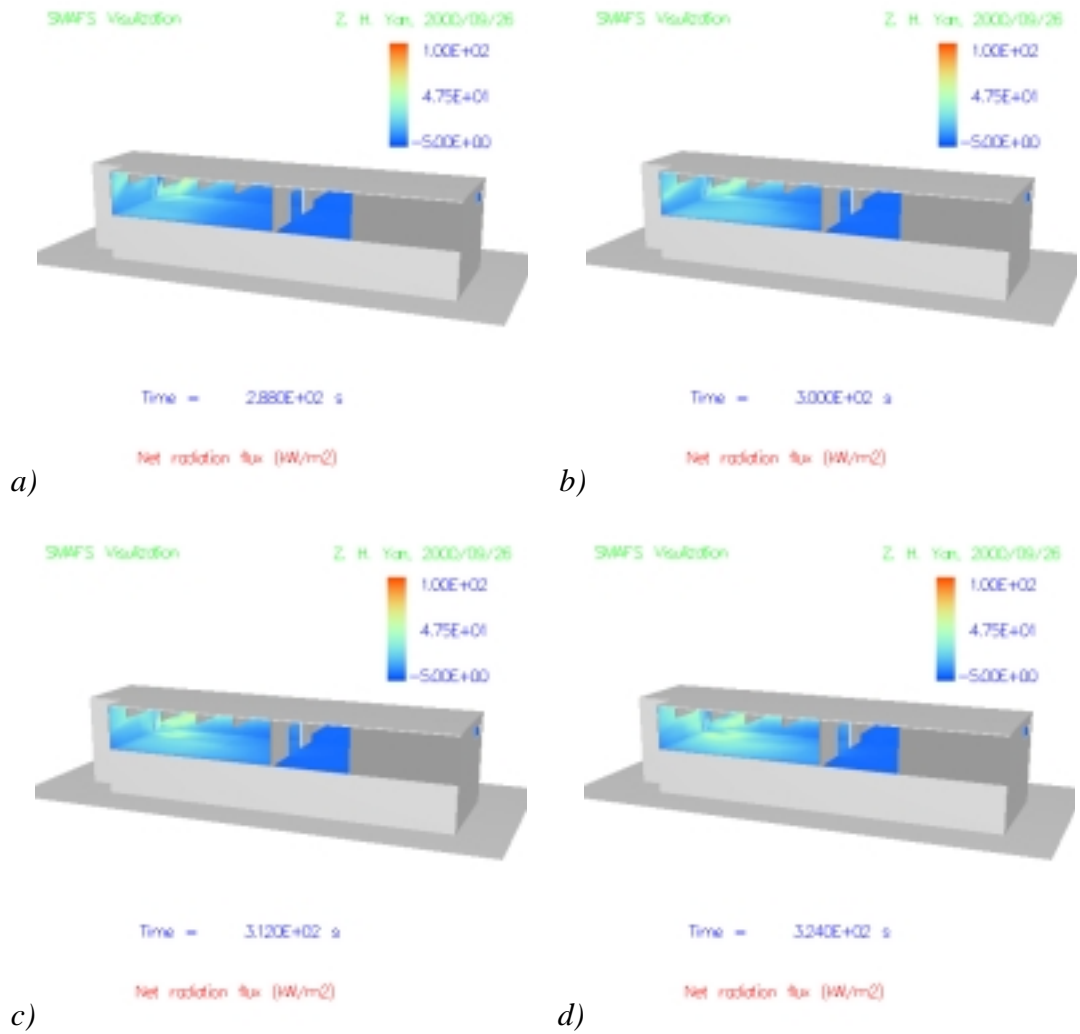
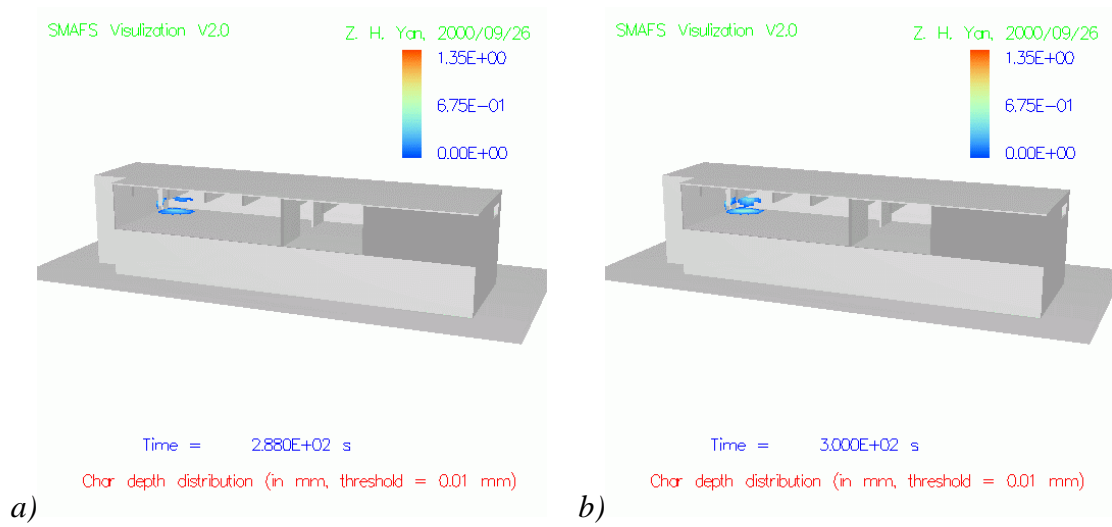

Fig. 15 Predicted transient developing of net radiation flux



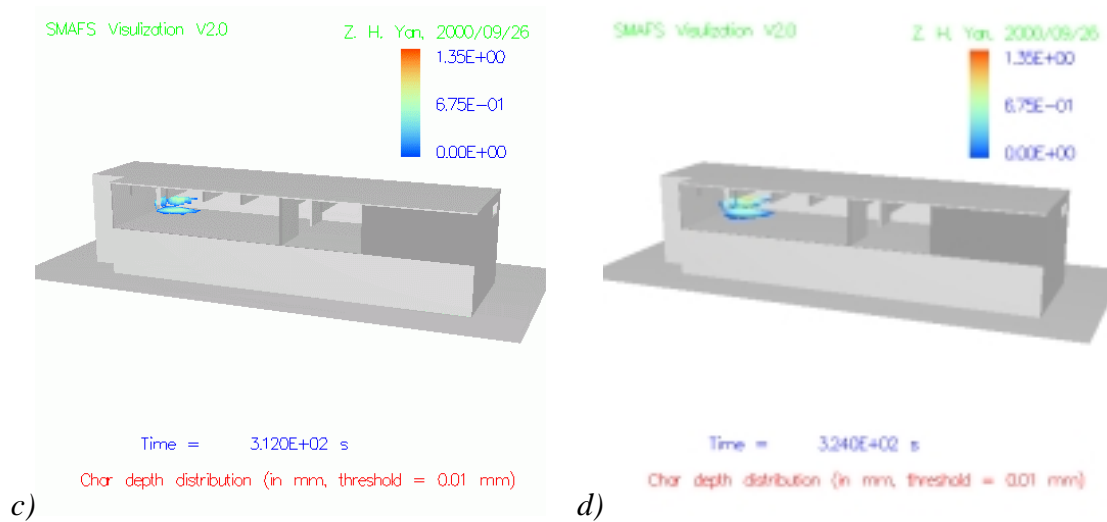

Fig. 16 Predicted transient developing of char layer

Due to the strong uneven heating, a substantial thermal stress could be generated in the glass windows and consequently these glass windows might break. Due to the insufficient supply of oxygen, an under ventilation condition was quickly reached in the dance hall. Therefore, once the windows were broken, flame came out from the windows and an intensive combustion extended outside of the building, as shown in Fig. 17. This big window flame, together with the combustion inside the fire building, imposed some strong heating and thus a considerable danger to the neighboring buildings. Fig. 18 shows the predicted radiation heat flux to a surface of building which was assumed to be located 3.3 meters away from the fire building.

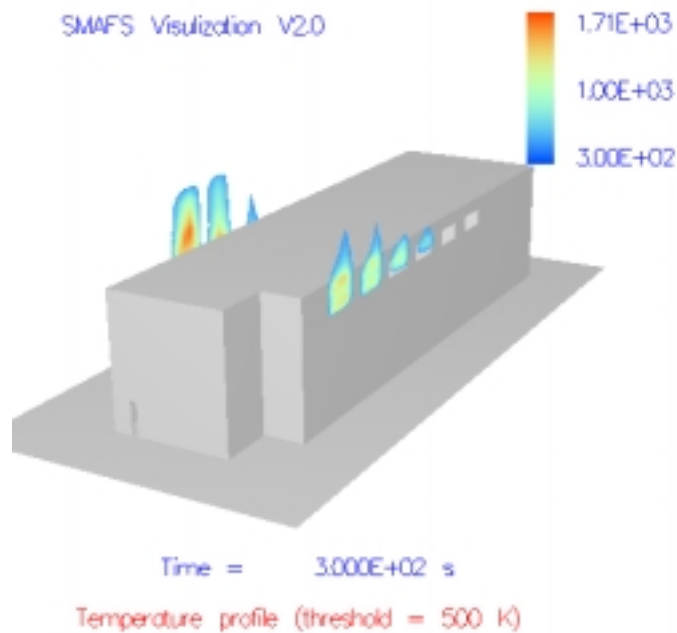

Fig. 17 Temperature profile of the window flame

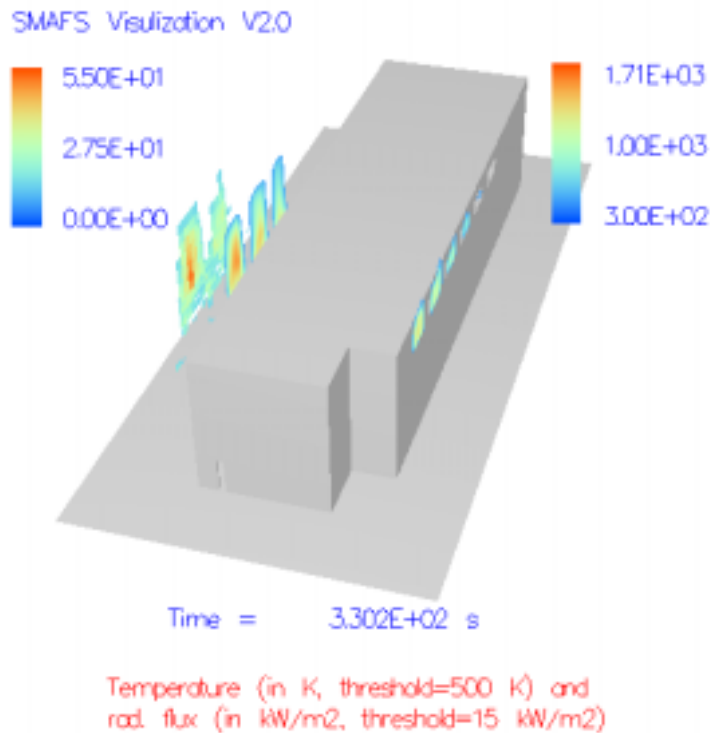
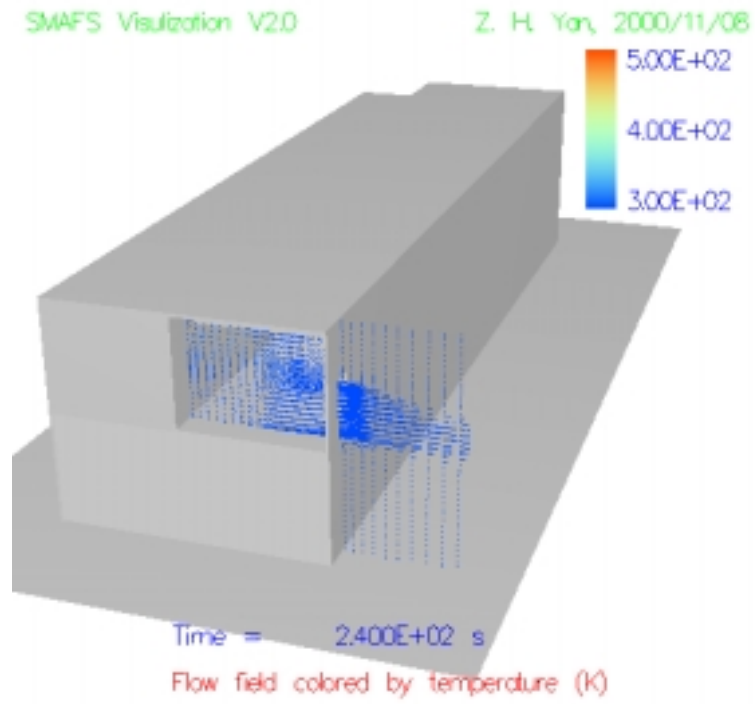
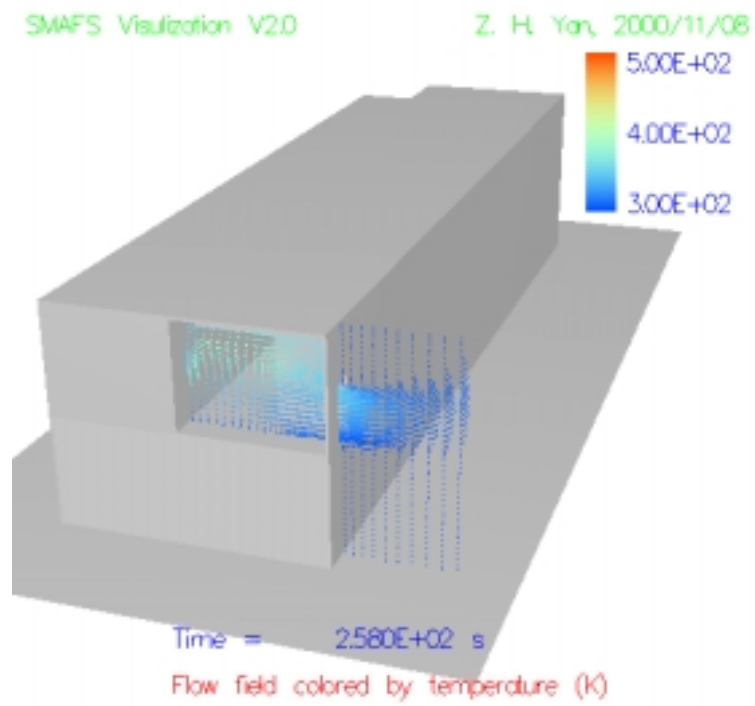

Fig. 18 Radiation flux to a solid surface 3.3 meters away from fire building

The breakage of windows also created significant influence on fluid dynamics. Driven by the pressure mainly generated by thermal expansion, the smoke came out of the building from the backside door of the building when the windows were closed. Once these windows were broken, some large smoke exits were created. At these exits, the path length is shorter and thus pressure-gradient is higher than at the backside doorway. As a result, smoke started to come out of the building mainly from the broken windows. With additional strong influence of buoyancy, flow at the backside door changed its direction and consequently the backside door became a route for the entrainment of fresh air. Due to the entrained fresh air, the backyard of the building became relatively safer. The transient flow pattern during this process is illustrated in Fig. 19. This predicted flow dynamics lies in an agreement with the observation of fire fighters.



a)



b)

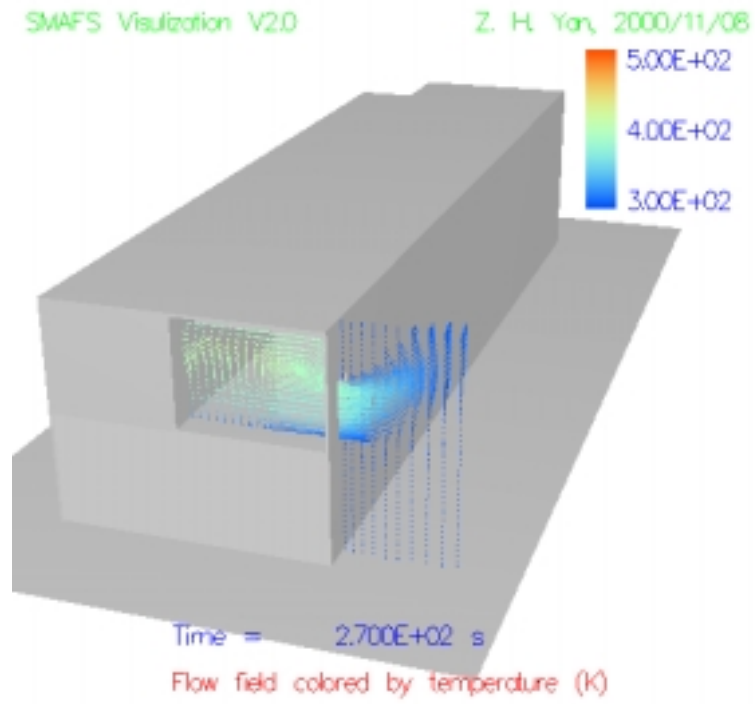

c)

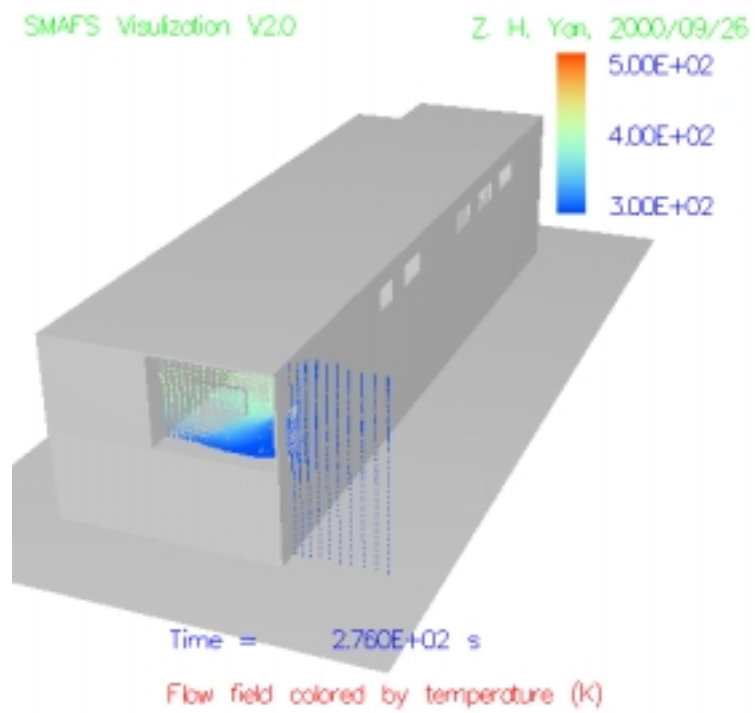

d)

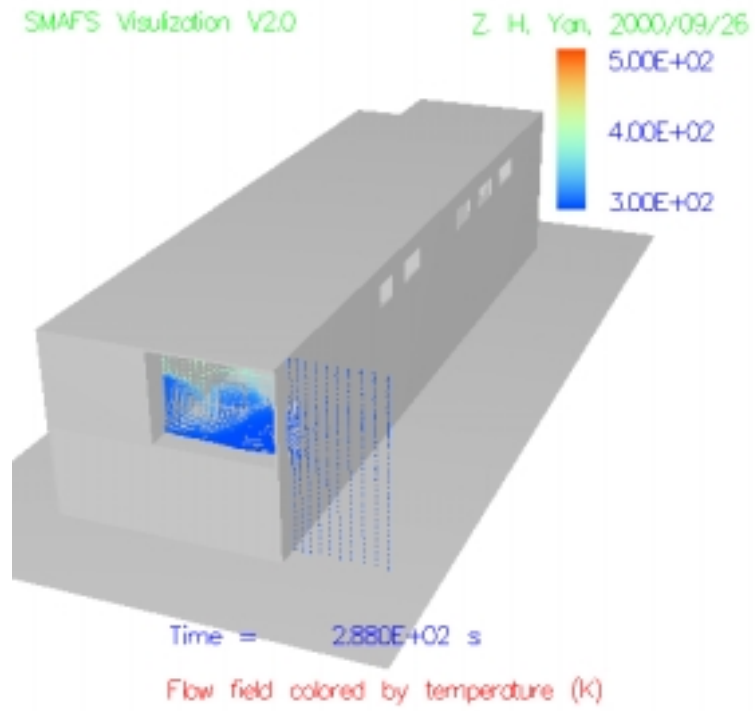

e)

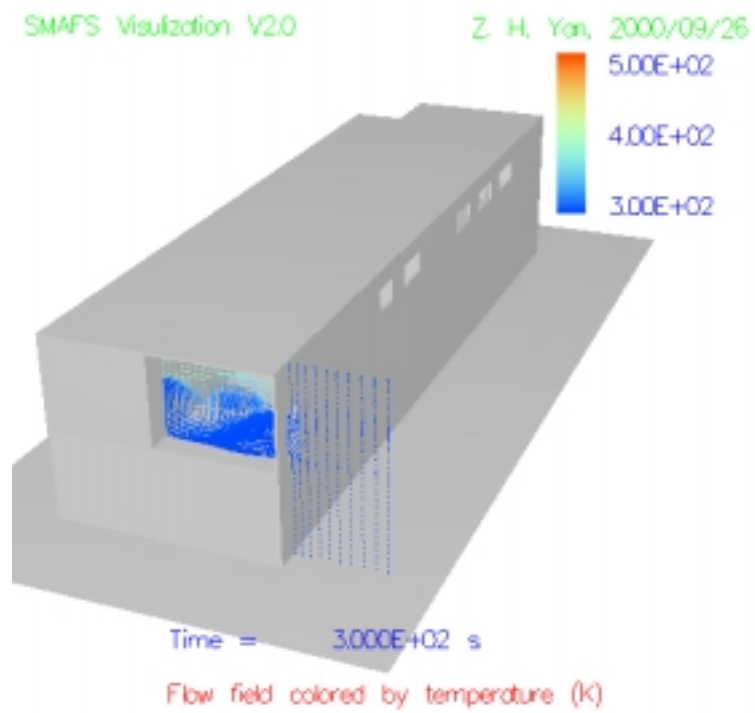

f)

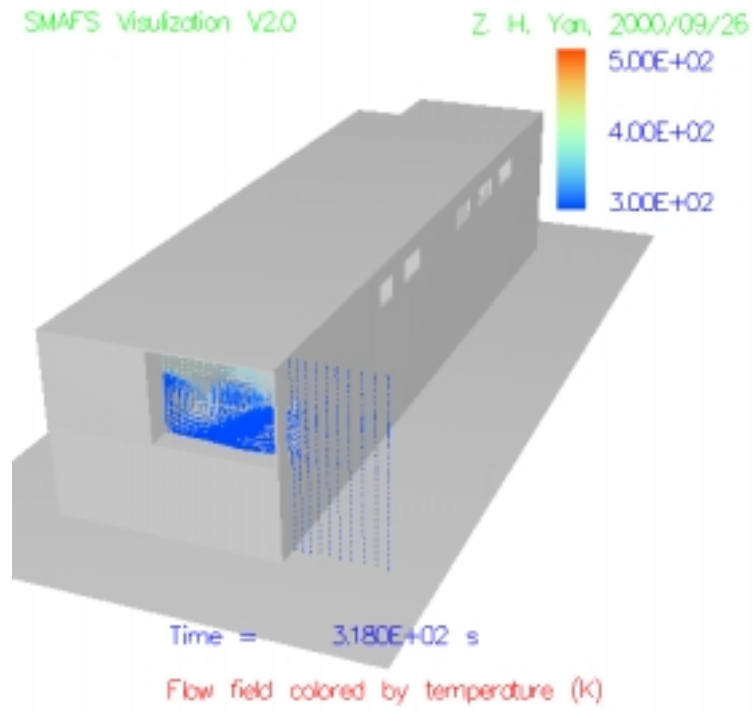

g)

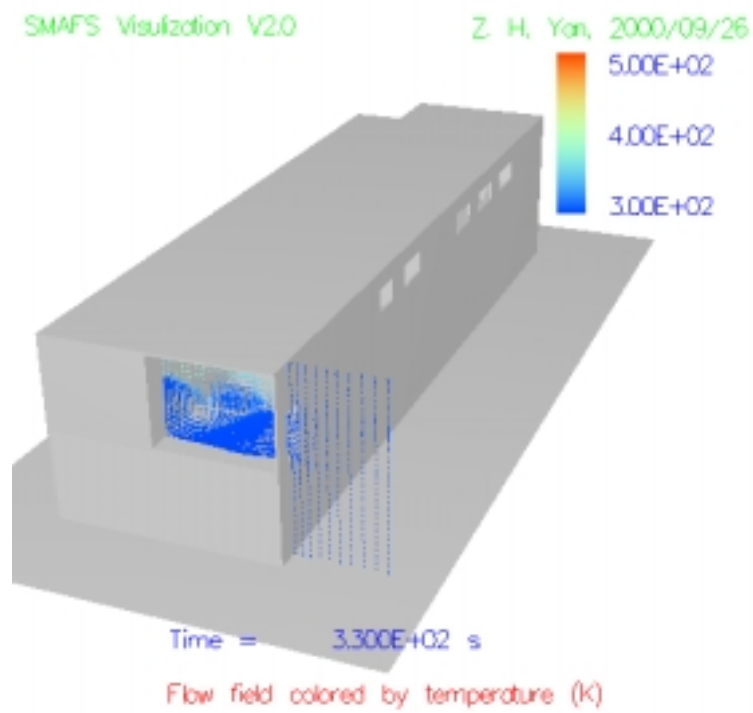

h)

Fig. 19 Transient development of flow field close to the backside door

To provide more detail information of the simulated fire process, some typical plots of heat flux in the stairwell, CO₂ and soot volume fraction profiles are given below in Figs 20-22. Since the fuel of the starting fire source was assumed to be propane in the simulation, the predicted soot volume fraction can be lower than the soot volume fraction in the real fire.

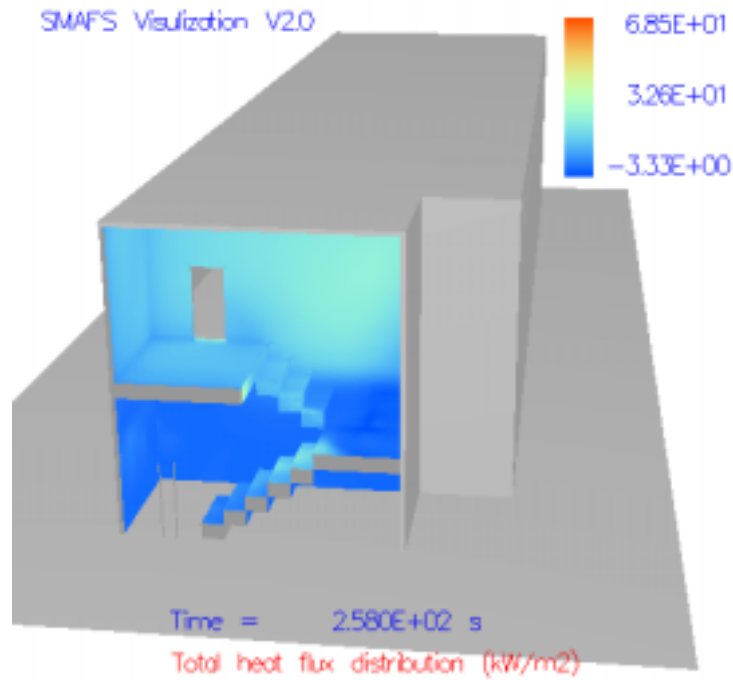
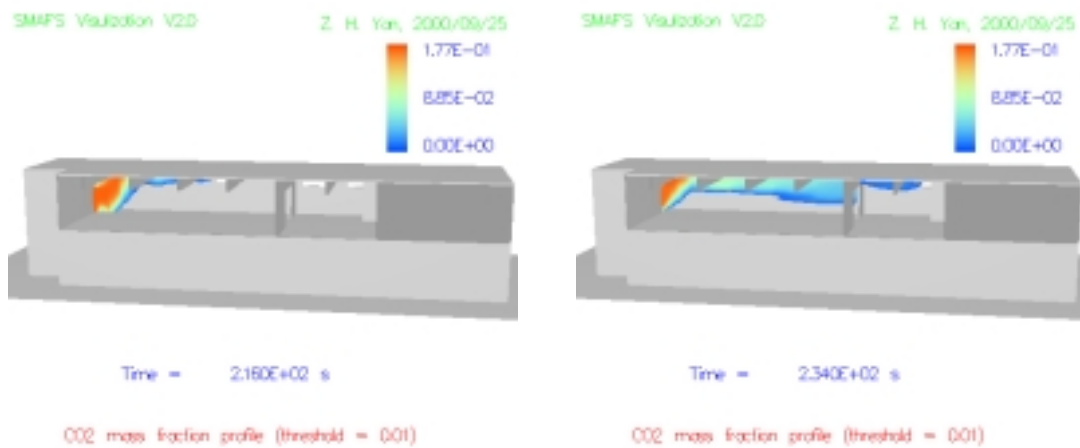
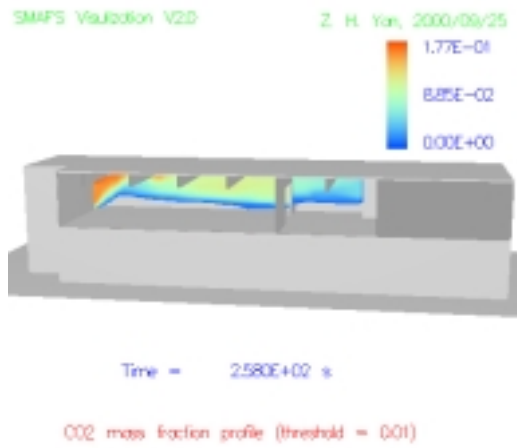

Fig. 20 Heat flux distribution in the stairwell at t= 258 s



a)

b)



c)

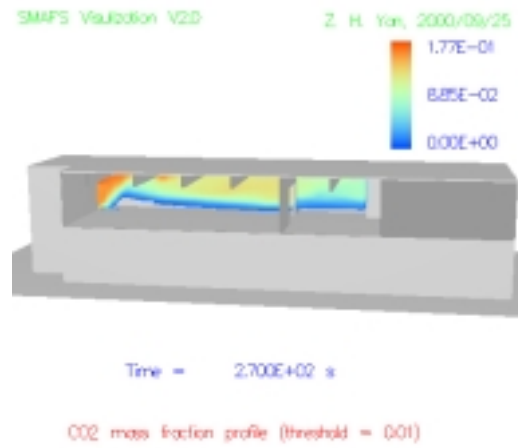

d)

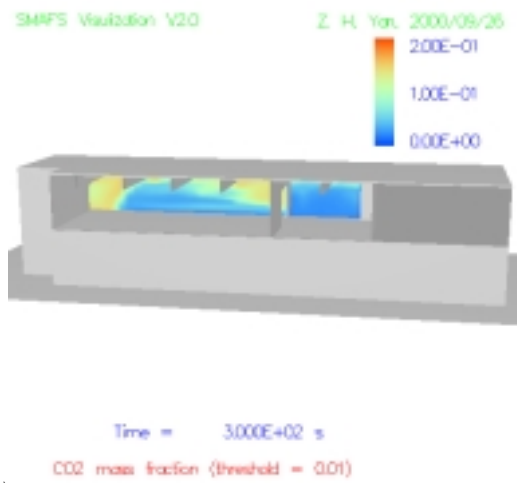

e)

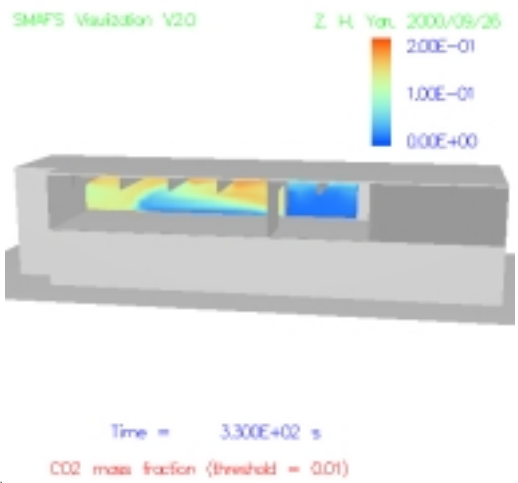

f)

Fig. 21 Predicted transient developing of an example CO2 profile in dance hall

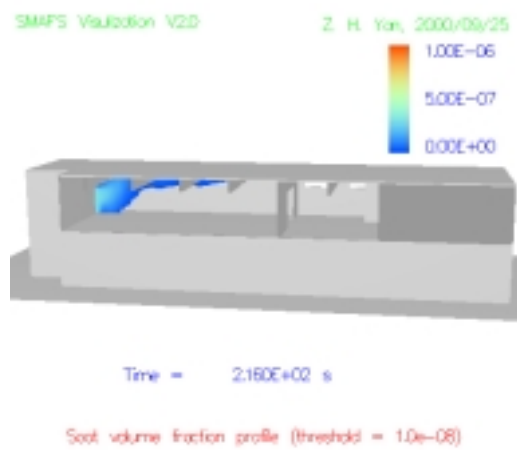

a)

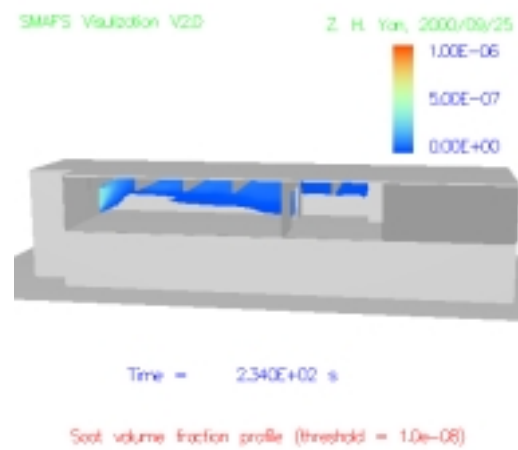

b)

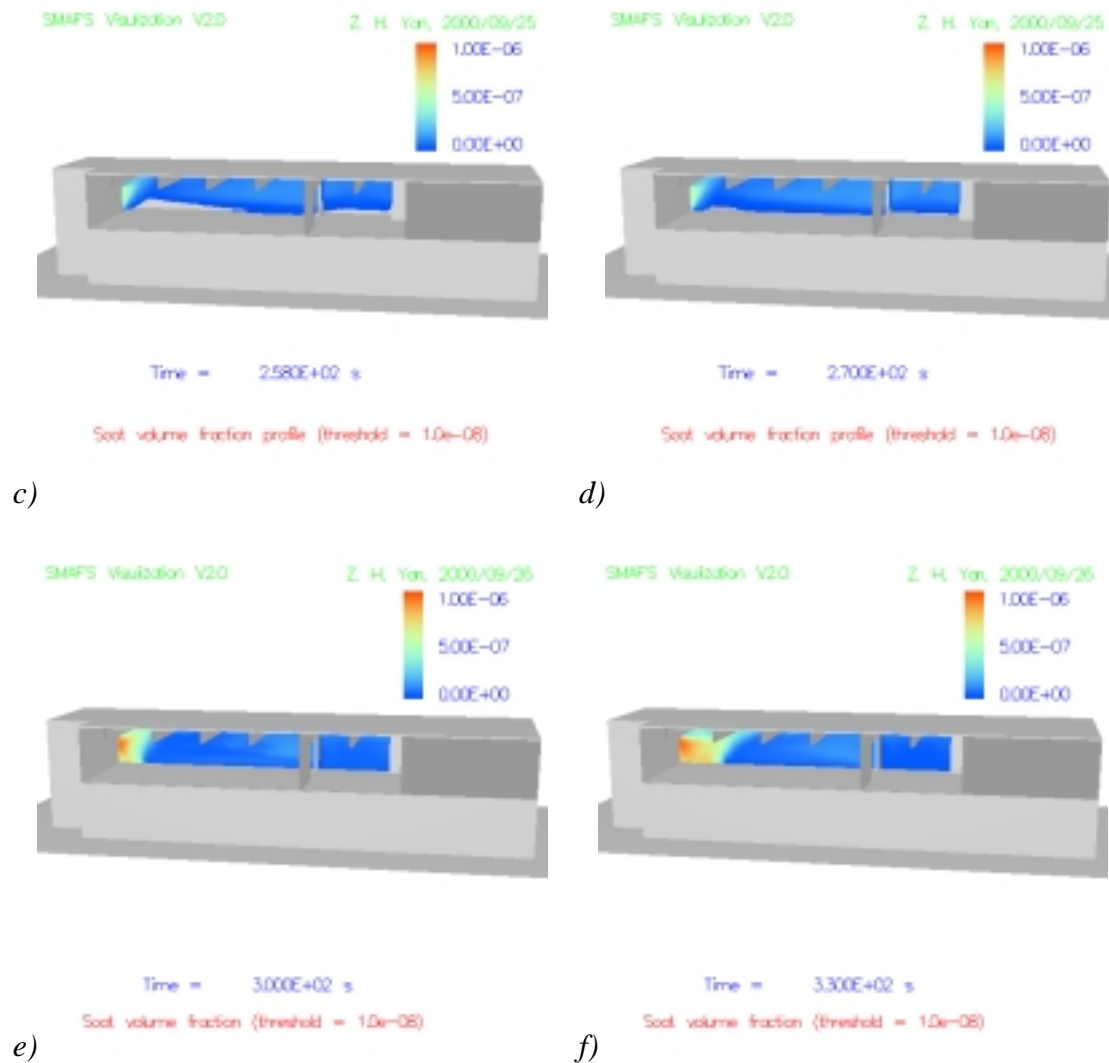

Fig. 22 Predicted transient developing of soot volume fraction profile in dance hall

CONCLUSIONS

Numerical simulation of turbulent combustion and flame spread in a large complex fire has been carried out to investigate the well-known Göteborg fire accident. This comprehensive computation includes modeling of turbulence, turbulent combustion, sooting, radiation, heat conduction and pyrolysis of solid fuel. The results of this simulation show a good agreement with the available observation of the real fire accident. With the obtained detail information on the fire dynamic and flame spread processes, the simulation helps explain the observed fire phenomena.

The accomplishment of this applied computation demonstrates the capability of the available modeling technology in fire safety design and fire accident investigation, and thus indicates a great potential usage of the modeling in practical applications.

ACKNOWLEDGEMENT

This applied computation was financially supported by SRV and SHK, which are gratefully acknowledged. The administrating board of the super computer Embla in Lund University is highly appreciated for providing the access to the computing resource.

REFERENCE

1. Haukur Ingason, Modellförsök av Diskteksbrände i Makedoniska Föreningens Lokaler, Report BRs1079, SP, Sweden, 2000
2. W. Rodi, Turbulence Models and Their Application in Hydraulics - A State of The Art Review, SBF Report 80/T/125, University of Karlsruhe (1980)
3. B. F. Magnussen and B. H. Hjertager, On Mathematical Modeling of Turbulent Combustion with Special Emphasis on Soot Formation and Combustion, 16th Symp. (Int.) on Combustion, The Combustion Institute, Pittsburgh, pp. 719-729, 1976
4. F. C. Lockwood & N. G. Shah, A New Radiation Solution Method for Incorporation in General Combustion Prediction Procedures, Eighteenth Symposium (International) on Combustion, The Combustion Institute, Pittsburgh, pp. 1405-1414, 1981
5. A. T. Modak, Radiation from Products of Combustion, Fire Research, vol. 1, pp. 339-361, 1978/1979
6. Z. H. Yan, Numerical Modeling of Turbulent Combustion and Flame Spread, Ph.D. thesis, Lund University, 1999