



LUND UNIVERSITY

Chloride concentration in preloaded compact tension concrete specimens

Hassanzadeh, Manouchehr

1993

[Link to publication](#)

Citation for published version (APA):

Hassanzadeh, M. (1993). *Chloride concentration in preloaded compact tension concrete specimens*. (Report TVBM (Intern 7000-rapport); Vol. 7067). Division of Building Materials, LTH, Lund University.

Total number of authors:

1

General rights

Unless other specific re-use rights are stated the following general rights apply:

Copyright and moral rights for the publications made accessible in the public portal are retained by the authors and/or other copyright owners and it is a condition of accessing publications that users recognise and abide by the legal requirements associated with these rights.

- Users may download and print one copy of any publication from the public portal for the purpose of private study or research.
- You may not further distribute the material or use it for any profit-making activity or commercial gain
- You may freely distribute the URL identifying the publication in the public portal

Read more about Creative commons licenses: <https://creativecommons.org/licenses/>

Take down policy

If you believe that this document breaches copyright please contact us providing details, and we will remove access to the work immediately and investigate your claim.

LUND UNIVERSITY

PO Box 117
221 00 Lund
+46 46-222 00 00



LUNDS TEKNISKA HÖGSKOLA
Byggnadsmaterial

UNIVERSITY OF LUND
LUND INSTITUTE OF TECHNOLOGY
Division of Building Materials

**CHLORIDE CONCENTRATION IN PRELOADED
COMPACT TENSION CONCRETE SPECIMENS**

Manouchehr Hassanzadeh

Rapport TVBM-7067

Lund, 1993



LUNDS TEKNISKA HÖGSKOLA
Byggnadsmaterial

UNIVERSITY OF LUND
LUND INSTITUTE OF TECHNOLOGY
Division of Building Materials

**CHLORIDE CONCENTRATION IN PRELOADED
COMPACT TENSION CONCRETE SPECIMENS**

Manouchehr Hassanzadeh

P-93:1

**CHLORIDE PENETRATION
INTO CONCRETE STRUCTURES**

Nordic Miniseminar, January 1993

(Byggnadsmaterial, CTH)

Edited by Lars-Olof Nilsson

Rapport TVBM-7067

Lund, 1993

CHLORIDE CONCENTRATION IN PRELOADED COMPACT TENSION CONCRETE SPECIMENS

Manouchehr Hassanzadeh
Division of Building Materials
Lund Institute of Technology

Introduction

The synergetic effect of the mechanical and environmental loads is usually neglected when long-term performance of concrete structures is studied. Disregarded synergetic effects may lead to erroneous estimation of the long-term behaviour of concrete structures designed to withstand severe environmental conditions and high mechanical stresses at the same time. The work of Schneider et.al. (1990 - 1992) and Piasta (1992) demonstrates the fact that deterioration of concrete in an aggressive medium is accelerated in the presence of mechanical stresses. Inversely, time to failure of the concrete specimens is shortened considerably in a sustained tensile loading, when an aggressive medium is presented.

In the literature, the synergetic effect of the mechanical and environmental loads is denoted as "stress corrosion". The stress corrosion phenomenon for metals and plastics has been studied extensively, while the knowledge about stress corrosion in cementitious materials is very limited.

In order to further understand the stress corrosion phenomenon in cementitious materials, a preparatory investigation has been initiated at the Division of Building Materials. The aim of the investigation is to determine whether the strength and the fracture energy of the preloaded "Compact Tension Specimens" (CT) are influenced by different environments such as Natrium Sulphate solution, sea water, tensides, fresh water and self-desiccation. Besides mechanical tests, the Chloride ingress into specimens is also measured. The experimental procedures and results of the Chloride measurements will be presented in the following sections, while results of the mechanical tests will be published later.

Experimental procedures

The CT specimens are made of notched prisms with the edge dimensions 150, 100 and 70 mm. The notches are imposed on the same plane from three different directions; see Fig. 1. The remaining uncut part of the specimen, viz. the fracture surface, is 70 x 40 mm². The arrows on the figure show the position and the direction of the loads applied during the mechanical testing.

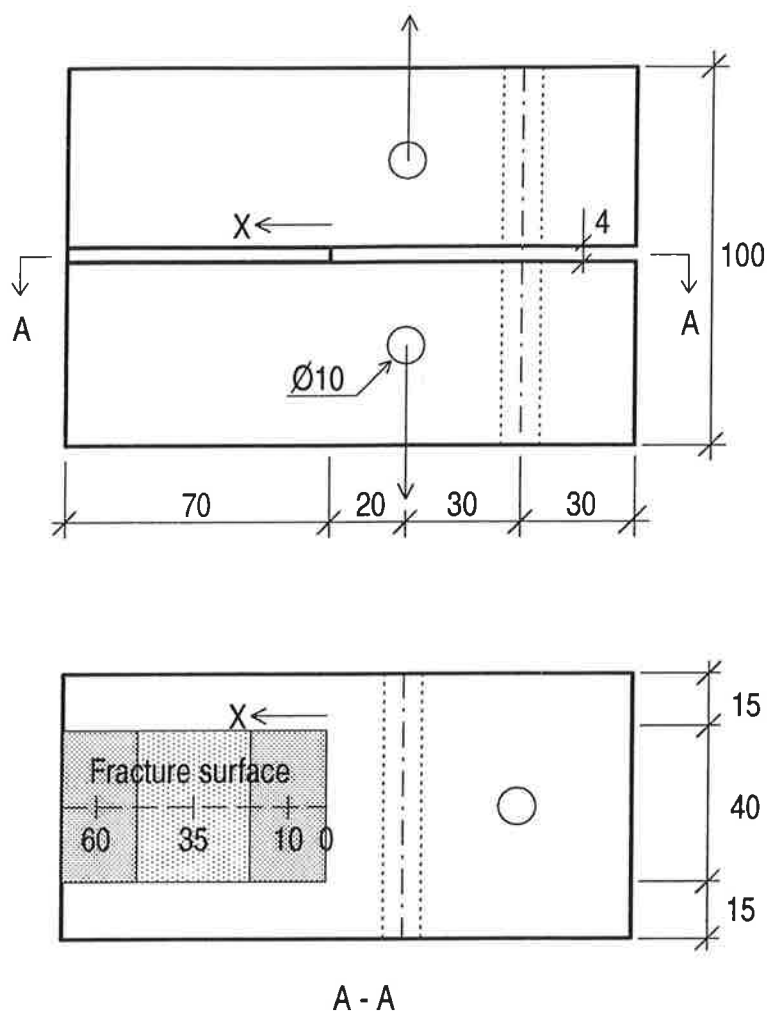

Fig. 1. Geometry of the compact tension specimen.

With respect to long-term loading the tests can be divided into three groups. The first group, the control group, is not loaded at all.

The second group is loaded to a certain level of their strength at 28 days of age and thereafter are subjected to stress relaxation during storage in sea water. Fig. 2 shows schematically the arrangement used for stress relaxation tests. As the figure illustrates, two unconnected threaded sockets are embedded in the specimen, located on both sides of the notch plane. The sockets contain bolts which can be screwed towards each other.

The load is applied to the specimen by a testing machine in displacement control. When the required load level is approached, the displacement is held constant while the bolts are screwed towards each other until they make contact and a small change in load is observed. Thereafter the specimen is unloaded, removed from the testing machine and stored in sea water. Since the bolts are in contact with each other, the specimen cannot be unloaded totally. Thus, residual stresses will arise within the specimen. The magnitude of the residual stresses depends upon the initial load imposed by the testing machine, and on the relaxation of the specimen which occurs during the storage in sea water.

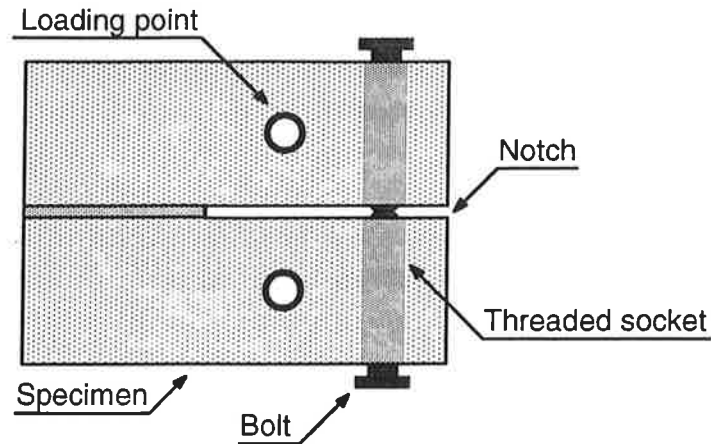

Fig. 2. Arrangement for stress relaxation tests.

The load levels which have been applied correspond to 30 and 60% of the specimens' strength. The strength of the specimens was determined by means of three tests.

The third group of specimens was subjected to an approximately constant load, viz. a load corresponding to 60% of the specimens' strength, during the storage in sea water. The loading arrangement is illustrated in Fig. 3.

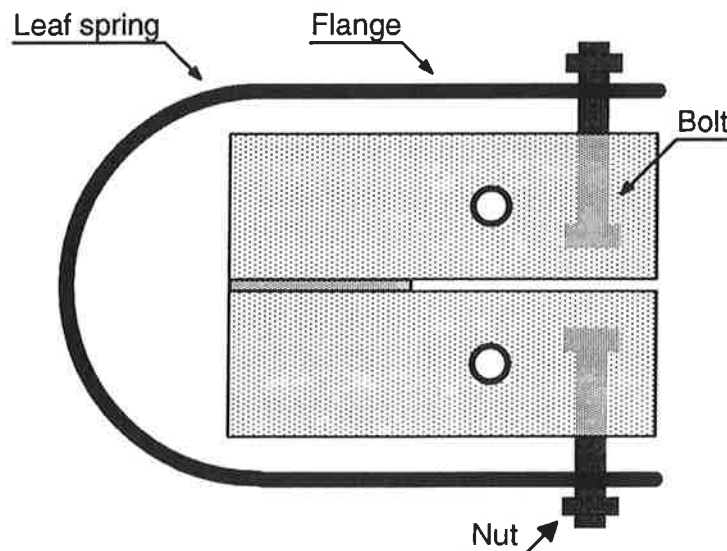

Fig. 3. Specimen subjected to constant load during storage in sea water.

As is illustrated, two bolts are embedded in the specimen on both sides of the notch plane. The bolts pass through holes on the flanges of the leaf spring. The load is imposed by compressing the flanges towards each other by an external load, fastening the nuts, and then removing the external load. Since the nuts oppose the reversed movements of the flanges, tensile load will be applied to the specimen through the bolts. The magnitude of the tensile load applied to the specimen will be somewhat lower than the initial external compressive load. The difference is caused by the displacement which occurs in the specimen. However, since the stiffness of the leaf spring (130 N/mm calculated for load - displacement at the

holes) and the displacement of the specimen (approximately 0.4 mm when separation of the specimen into two pieces occurs) are low, the difference between the external and the final load imposed on the specimen is negligible.

Experimental program

Two concrete qualities were tested. The composition of the concrete is given in Tab. 1.

Cement kg/m ³	Water kg/m ³	Water/Cement Ratio	Sand 0 - 8 kg/m ³	Quartzite 8 - 12 kg/m ³
299	172	0.58	812	1145
400	130	0.33	723	1214

Tab. 1. Concrete compositions used in the investigation.

The specimens were cast in wooden moulds. The specimens were demoulded the day after casting and stored in lime saturated water. 28 days after casting the specimens were removed from the lime saturated water and treated as described in the previous section.

All specimens were painted with epoxy prior to sea water storage. All sides of the specimens were painted. Furthermore, besides the notch tip at $x=0$, see Fig. 1, all other notch tips were also painted. However, the epoxy treatment of the notch tips was not effective due to the tightness of the notches.

Both control specimens and specimens for relaxation tests were stored 2 and 4 months in sea water, whereas the specimens loaded with leaf springs were stored 2 months. Tab. 2 concludes the test program.

Storage ↓	Control group	Relaxation test		Const. load test
	$P_i = 0 \times P_{max}$	$P_i = 0.3 \times P_{max}$	$P_i = 0.6 \times P_{max}$	$P_i = 0.6 \times P_{max}$
Two months	X	X	X	X
Four months	X	X	X	—

X = 3 specimens for each concrete quality.

— = Non.

Tab. 2. Test program.

Chloride measurements

After termination of the storage period in sea water and mechanical tests, the Chloride concentration on fracture surfaces was measured. The measurements were conducted on material dust produced by milling of the fracture surfaces. Determination of the Chloride concentration was conducted by means of a Chloride - Sensitive - Electrode test method. The milling was conducted on three sections, with the mid-sections located 10, 35 and 60 mm from the notch tip; see Fig. 1. The milling depth was approximately 2 mm on each half of the specimen. Results are presented in Figs. 4 and 5. It should be noted that the Chloride concentrations are given in percent of the concrete mass and nothing else.

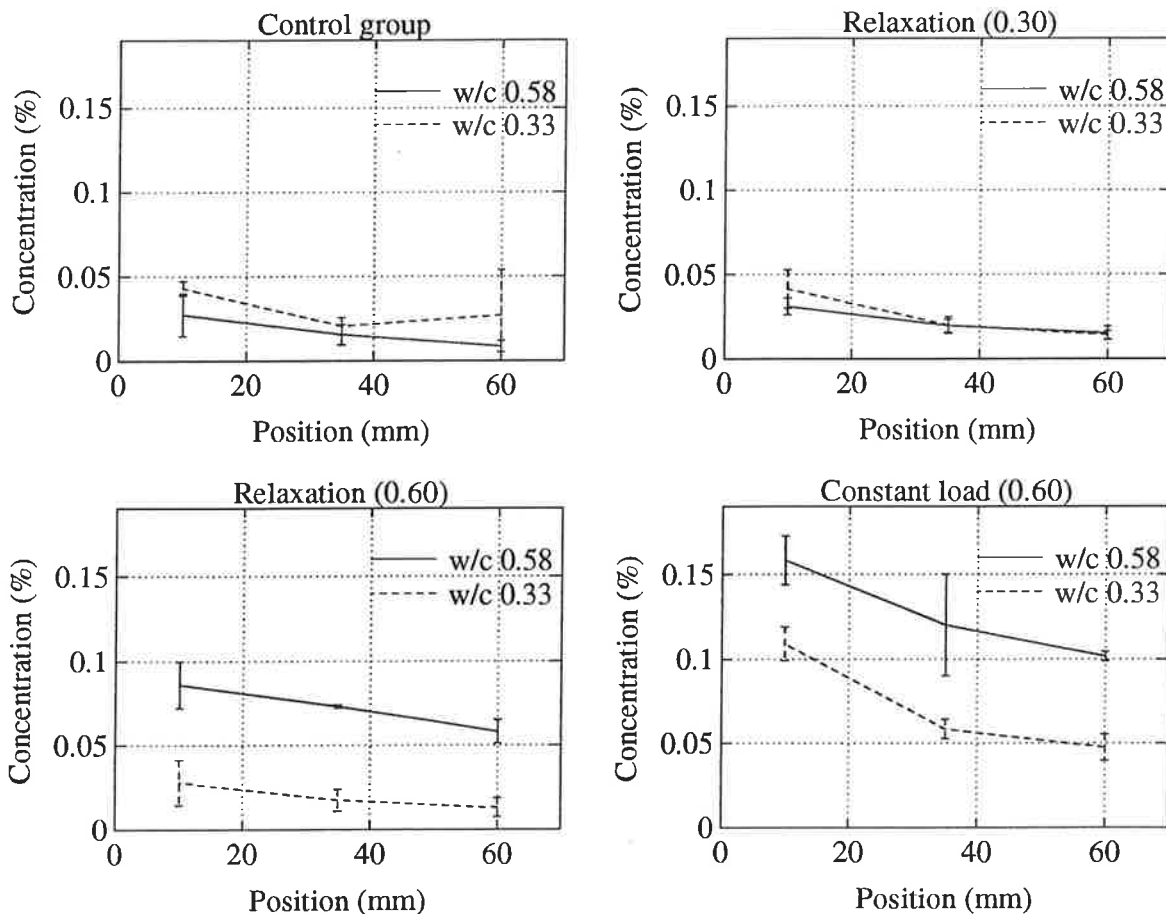

Fig. 4. Chloride concentration after two months of storage in sea water.

Discussions

The results of the control group demonstrate that the painting of the notch tips by epoxy did not give the protection which was expected. The Chloride ingress has occurred from all notch tips. However, the Chloride ingress from the notch tip which was not painted at all ($x=0$) is higher than the notch tips treated by epoxy; compare the positions $x=10$ mm and $x=60$ mm.

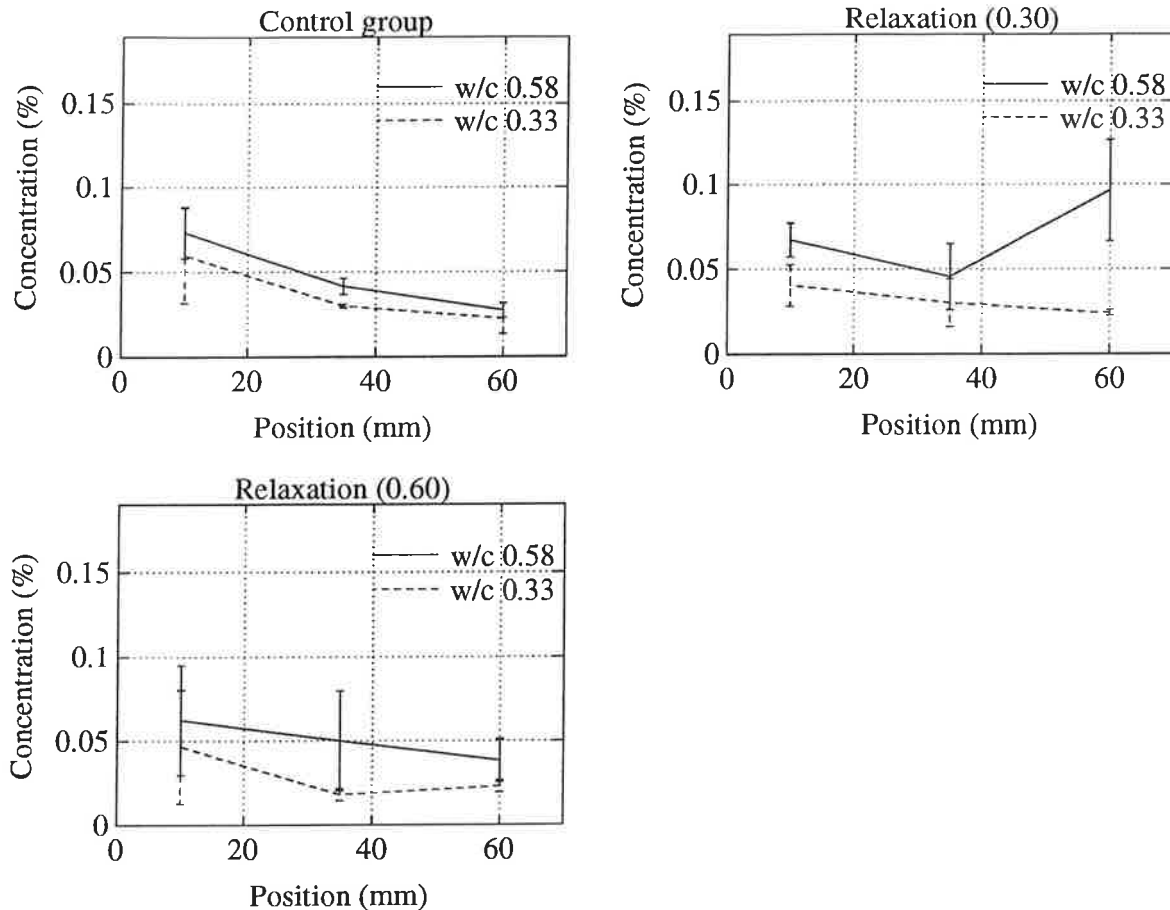

Fig. 5. Chloride concentration after four months of storage in sea water.

Comparison between results of the control group and results of the relaxation tests indicates that there is no significant increase of Chloride ingress due to the presence of residual stresses at notch tip. However, in contrast with the relaxation tests, the ingress of the Chloride is significantly increased in the case of constant load tests. The reason for the observed phenomenon is not known. However, the following explanations are somewhat realistic.

In relaxation tests, the stress concentrations at notch tips decrease and the self-healing process of concrete closes the micro cracks which may have occurred due to the stress concentration at the notch tips. In the case of constant load tests, however, creep occurs, which in spite of self-healing of concrete gives rise to continuous formation of new micro cracks.

In order to more closely examine the significant differences between control group, relaxation and constant load tests, a straight lines are fitted to the test results by means of the Least Square Method. The possible influences of the concrete quality and storage time on Chloride ingress into specimens have been neglected; see Fig. 6. The figure shows that there is no significant difference between Chloride ingress in control specimens and in the specimens of the relaxation tests. Furthermore, the figure shows that the Chloride ingress increases significantly in the case of the specimens subjected to constant load.

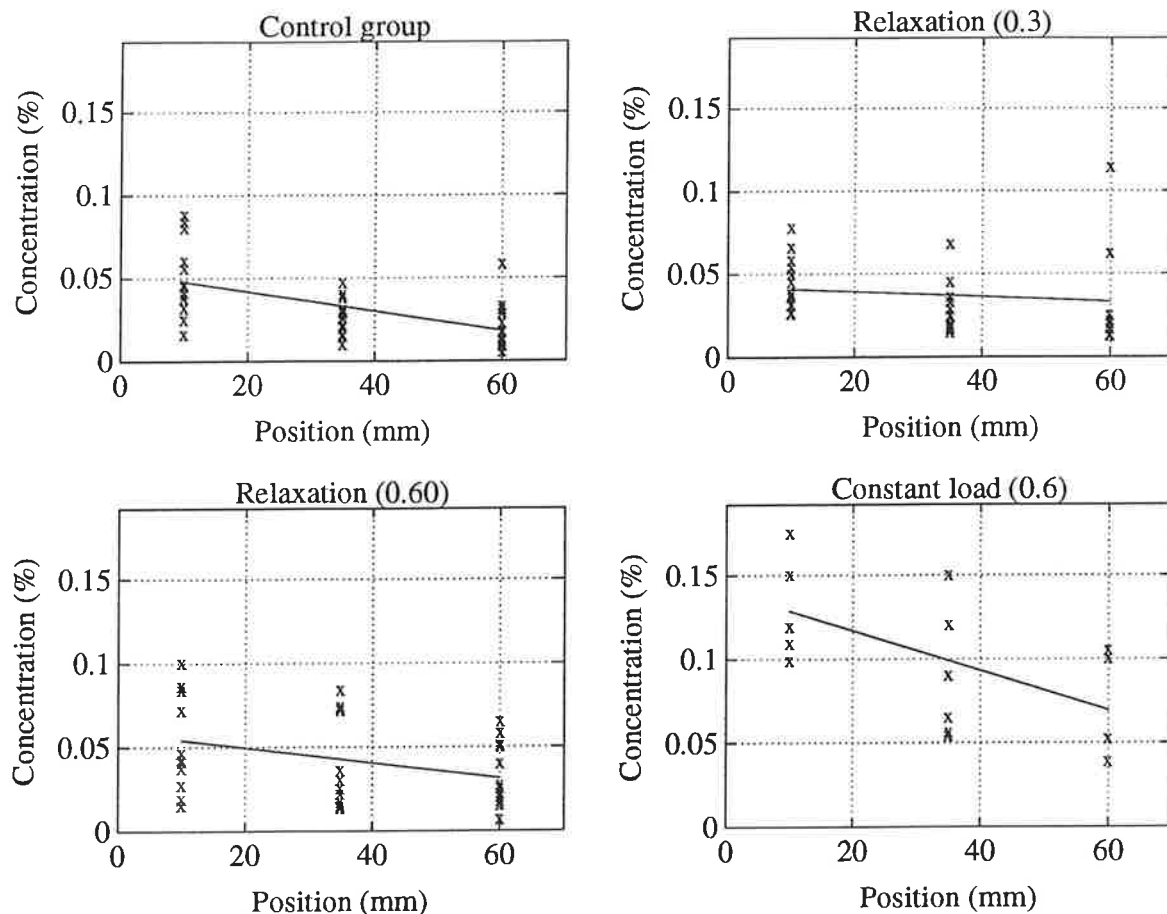

Fig. 6. Influence of stress on chloride ingress.

References

- Piasta, W.G. and Schneider, U. (1992) Deformations and elastic modulus of concrete under sustained compression and sulphate attack, *Cement and Concrete Research*, vol. 22, pp. 149-158.
- Schneider, U., Piasta, J., Nägele, E. and Piasta, W. (1990) Stress corrosion of cementitious materials in sulphate solutions. *Materials and Structures*, 23, 110-115.
- Schneider, U., Nägele, E., Dumat, F. and Holst, S. (1992) Der einfluß mechanischer spannungen auf den korrosionswiderstand zementgebundener Baustoffe. In *Deutscher Ausschuss für Stahlbeton*, Beuth verlag Gmbh, Berlin, Köln.