



# LUND UNIVERSITY

## A technical survey of wireless sensor network platforms, devices and testbeds

Omiyi, Peter; Bür, Kaan; Yang, Yang

2008

*Document Version:*

Publisher's PDF, also known as Version of record

[Link to publication](#)

*Citation for published version (APA):*

Omiyi, P., Bür, K., & Yang, Y. (2008). *A technical survey of wireless sensor network platforms, devices and testbeds*. (AIRBUS-01-190308 ed.) (Technical Report; Vol. EP/F004532/1 AIRBUS-01-190308). University College London.

*Total number of authors:*

3

### General rights

Unless other specific re-use rights are stated the following general rights apply:

Copyright and moral rights for the publications made accessible in the public portal are retained by the authors and/or other copyright owners and it is a condition of accessing publications that users recognise and abide by the legal requirements associated with these rights.

- Users may download and print one copy of any publication from the public portal for the purpose of private study or research.
- You may not further distribute the material or use it for any profit-making activity or commercial gain
- You may freely distribute the URL identifying the publication in the public portal

Read more about Creative commons licenses: <https://creativecommons.org/licenses/>

### Take down policy

If you believe that this document breaches copyright please contact us providing details, and we will remove access to the work immediately and investigate your claim.

LUND UNIVERSITY

PO Box 117  
221 00 Lund  
+46 46-222 00 00

# **A TECHNICAL SURVEY OF WIRELESS SENSOR NETWORK PLATFORMS, DEVICES AND TESTBEDS**

**A Report for the  
Airbus/ESPRC Active Aircraft Project  
EP/F004532/1: Efficient and Reliable Wireless Communication Algorithms  
for Active Flow Control and Skin Friction Drag Reduction**

**19 March 2008**

**Eitan Omiyi, Kaan Bür and Yang Yang  
Dept of Electronic and Electrical Engineering  
University College London  
Gower Street, London WC1E 6BT  
TEL: 020 7679 3973  
EMAIL: y.yang@ee.ucl.ac.uk**

## **Executive Summary**

This report presents a review of the state-of-the-art wireless sensor/actuator (WSA) node platforms, networks (WSN) and network testbeds. Three key node platform families are identified, namely the BTnode, Mica family and Imote2, as potential candidates for implementing a wireless sensor/actuator network testbed for the Airbus/ESPRC Active Aircraft Project. Furthermore, the review of the currently available testbeds offers useful insights into the design of the proposed new testbed.

1	Introduction.....	3
2	State-of-the-Art WSA Node Platforms .....	3
2.1	MSB430 .....	4
2.2	Tmote Sky.....	6
2.3	BTnode .....	9
2.4	EyesIFXv2.....	11
2.5	MICAz Mote.....	14
2.6	MICA2 Mote .....	16
2.7	MICA2DOT Mote .....	16
2.8	Imote2 .....	16
2.9	Summary .....	18
3	State-of-the-Art in WSN Testbeds .....	20
3.1	Institutes in the UK and Europe .....	20
3.2	Institutions in the USA.....	21
3.3	Summary .....	24
4	References .....	25

## 1 Introduction

This report reviews the current status of wireless sensor/actuator (WSA) node platforms, networks (WSN) and network testbeds. In the first part of the report, a set of the most widely deployed WSA node platforms are reviewed and analysed, on the basis of their components and capabilities. From this initial set, a sub-set of high performance nodes are identified for possible use in implementing the proposed wireless sensor/actuator network testbed for the Airbus/ESPRC Active Aircraft Project. The testbed is to be used as a development and evaluation platform for novel high performance medium access control (MAC) and routing algorithms for application in the proposed aircraft nervous system for active flow control. In the latter part of the report, a survey of existing testbeds is also presented in order to identify a suitable niche for the proposed new Airbus/UCL testbed.

## 2 State-of-the-Art WSA Node Platforms

The following is a selection of the state-of-the-art in WSA node platforms currently deployed in research and commercial applications.

- MSB430, ESB
- TmoteSky
- BTnodes
- EyesIFXv2
- MicaZ
- Mica2
- Mica2Dot
- Imote2

The different platforms are discussed and compared against one another on the basis of the following criteria.

- Microprocessor unit (MPU)
- Radio transceiver(s)
- Data rate
- Software and operating system
- Memory and storage
- Sensors and actuators
- Applications
- Protocol development interface
- External Interfaces
- Wireless programming interface
- Legacy network access
- Energy supply
- Size
- Support and availability
- Cost

## 2.1 MSB430

The Modular Sensor Board (MSB) is the new version of the universal module especially designed for research and education by ScatterWeb, a spin-off of the Free University of Berlin [1]. Its predecessor, the embedded sensor board (ESB), is in use at many universities and research institutions across Europe. It has the following key features.

**MPU:** The MSB430 uses a MSP430F1612IPM processor with 55 kB Flash, 5 kB RAM.

**Radio:** A Texas Instruments CC1020 radio transceiver is the default communication device of the MSB430. It operates in the 868 MHz ISM band and achieves a maximum data rate of 153.6 kbs (typical data rate is 19 kbps). Furthermore, several external connectors to the MPU exist that can be used to include additional transceivers. Thus, access to GSM/GPRS, Bluetooth, 802.11 and other commercial or local wireless networks possible.

**Sensors/Actuators:** The MSB430 has the following in-built sensors/actuators: humidity sensor (Sensirion SHT11), temperature sensor (Sensirion SHT11) and three-axis accelerometer MMA7260Q and a red LED. Additional sensors/actuators may be attached via the available external connectors to the MPU.

**External interfaces:** The external interfaces include an SD-card socket, JTAG interface, and several external connectors to the MPU.

**Wireless programming interface:** Remote wireless (re)programming of nodes is possible using the Embedded Gate/USB and the Embedded Gate/WEB devices that are connected to PCs. These interfaces also enable debugging and the collecting of sensor data. Additional transceivers can also be connected to the MPU to enable out-of-band remote wireless reconfiguration of nodes.

**Legacy network access:** Access to other wireless networks is possible using the Embedded Gate/USB and the Embedded Gate/WEB devices to connect nodes to a PC that is connected to a legacy network.

**Applications:** Applications include environmental monitoring, enhanced mobile entertainment, intelligent buildings, disaster recovery and ad-hoc networking.

**Protocol development interface:** Open access to configure MAC and Routing algorithm using the JTAG interface to program the MPU, which is directly responsible for writing data bytes to the radio transceiver via the MPUs UARTs. The degree of flexibility is subject to hardware constraints. The transceiver provides access to channel sensing and RSSI data that can be used in various protocol implementations.

**Software and operating system:** A C interface is available for programming the nodes with the ScatterWeb operating system but nesC with the tinyOS with can also be used.

**Energy Sources:** The MSB430 can be powered by both a battery pack containing three AAA (1.5 V) batteries and through an external power-supply interface using, e.g., an external mains-connected voltage generator, a solar panel, or a high-power capacitor.

**Power Saving Modes:** Low power operation is partly due to the ultra low power TI MSP430 microcontroller, which features extremely low active and sleep current consumption. In order to minimize power consumption, it is in sleep mode most of the time, with fast wake-up to process each new task, and fast return to sleep mode after completing the task. The CC1020 radio supports programmable transmit power that enables low power applications.

**Memory and storage:** In addition to the on-board MPU 55 kB Flash and 5 kB RAM, and SD-card socket is also available that allows scalable additional data storage capacity.

**Cost:** The cost is approx. 100 Euros per node, excluding accessories.

**Size:** The size is 36 by 41 mm.

**Support and availability:** Online documentation available from the ScatterWeb website, as well as at the website of Freie Universität Berlin. The MSB hardware is available from ScatterWeb, while the software is obtained from the Freie Universität Berlin website. The MSB modular sensor board is provided for research and demos in the area of wireless sensor networks. It has not been certified nor tested for usage in any critical environment outside research labs. Scatterweb's customer support is focused mainly on its commercial products, though limited support is available for MSB, as well as from the Freie Universität Berlin.

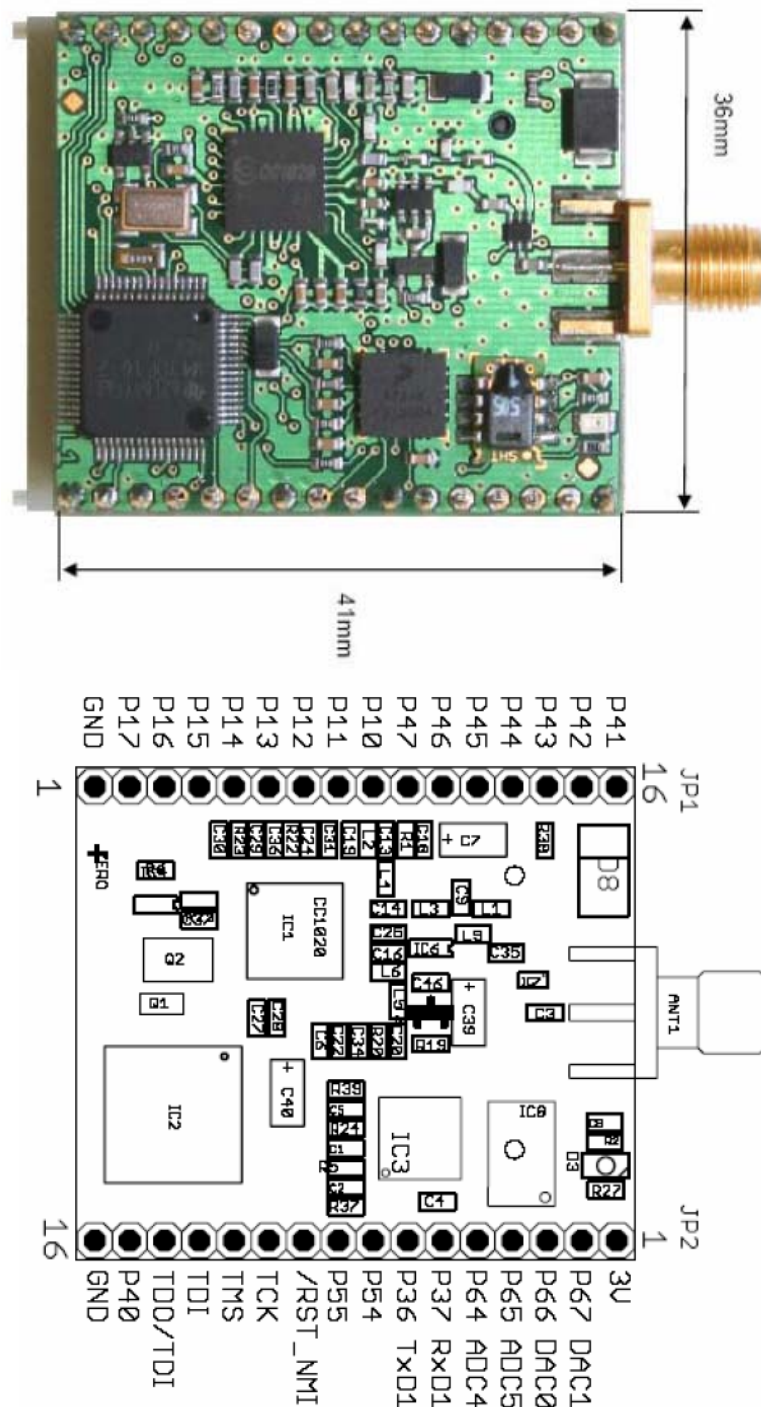

Figure 1. The MSB430 module

## 2.2 Tmote Sky

The Tmote Sky is a general purpose wireless sensor network platform with a large market share both in academia and industry. It is the successor of the popular TelosA and TelosB research platforms from UC Berkeley. Tmote Sky is one of the few FCC Certified wireless sensor network platforms available on the market. Tmote Sky was developed and supported by moteiv [2], which is now owned by Sentilla [3].

**MPU:** Tmote Sky uses a MSP430F1611 processor with 48 kB Flash, 10 kB RAM.

**Radio:** Tmote Sky uses an 802.15.4 compliant Texas Instruments CC2420 radio transceiver operating in the 2.4GHz ISM band at data rates of 250 kbps, 40 kbps, and 20 kbps. The transceiver employs a default CSMA-CA MAC.

**Sensors:** In addition to the internal temperature sensor of the MSP430 microcontroller, the Tmote Sky board has predefined positions for mounting a humidity/temperature sensor from Sensirion AG (models SHT11 and SHT15 are supported), as well as for light sensors like the Hamamatsu Corporation S1087 for sensing.

**External interfaces:** The external interfaces include USB and JTAG for (re)programming the CPU flash, as well as I2C, ADC, DAC and SPI. Tmote Sky has two expansion connectors and a pair of onboard jumpers that may be configured so that additional devices (analog sensors, LCD displays, and digital peripherals) may be controlled by the Tmote Sky module.

**Wireless programming interface:** Remote wireless (re)programming of nodes is not a standard feature of the Tmote Sky, and this can only be achieved by attaching a compatible transceiver to the JTAG connector that operates on a different channel than that of the default node communication device.

**Legacy network access:** Because each node has an 802.15.4 (ZigBee) compliant radio, it can communicate with legacy network gateway devices that are ZigBee compliant. Alternatively, an additional transceiver may be added to enable each node with access to a legacy network.

**Protocol development interface:** Tmote sky is equipped with a standard 802.15.4 protocol compatible transceiver. Thus, it offers limited flexibility for proprietary protocol development.

**Software and operating system:** It is tinyOS compatible.

**Energy Sources:** A battery pack containing two AA (1.5 V) batteries. The Tmote Sky can also be powered via the on-board USB interface when plugged into the USB port of a host computer for programming or communication.

**Power Saving Modes:** Low power operation is partly due to the ultra low power TI MSP430 microcontroller, which features extremely low active and sleep current consumption, as discussed in section 2.1. In order to minimize power consumption, it is in sleep mode most of the time, with fast wake-up to process each new task, and fast return to sleep mode after completing the task. The radio supports programmable transmit power that enables low power applications, and allows a power-off mode for low duty cycles.

**Memory and storage:** In addition to the on-board MPU 48 kB Flash and 10 kB RAM, a 1 MB serial flash, M25P80, that can be read and written by the MSP430.



**Cost:** The cost is approx. 130 USD per node, excluding accessories.

**Size:** The size is 3.2 cm by 6.55 cm by 0.66 cm.

**Support and availability:** There is online documentation but no customer support from Sentilla.

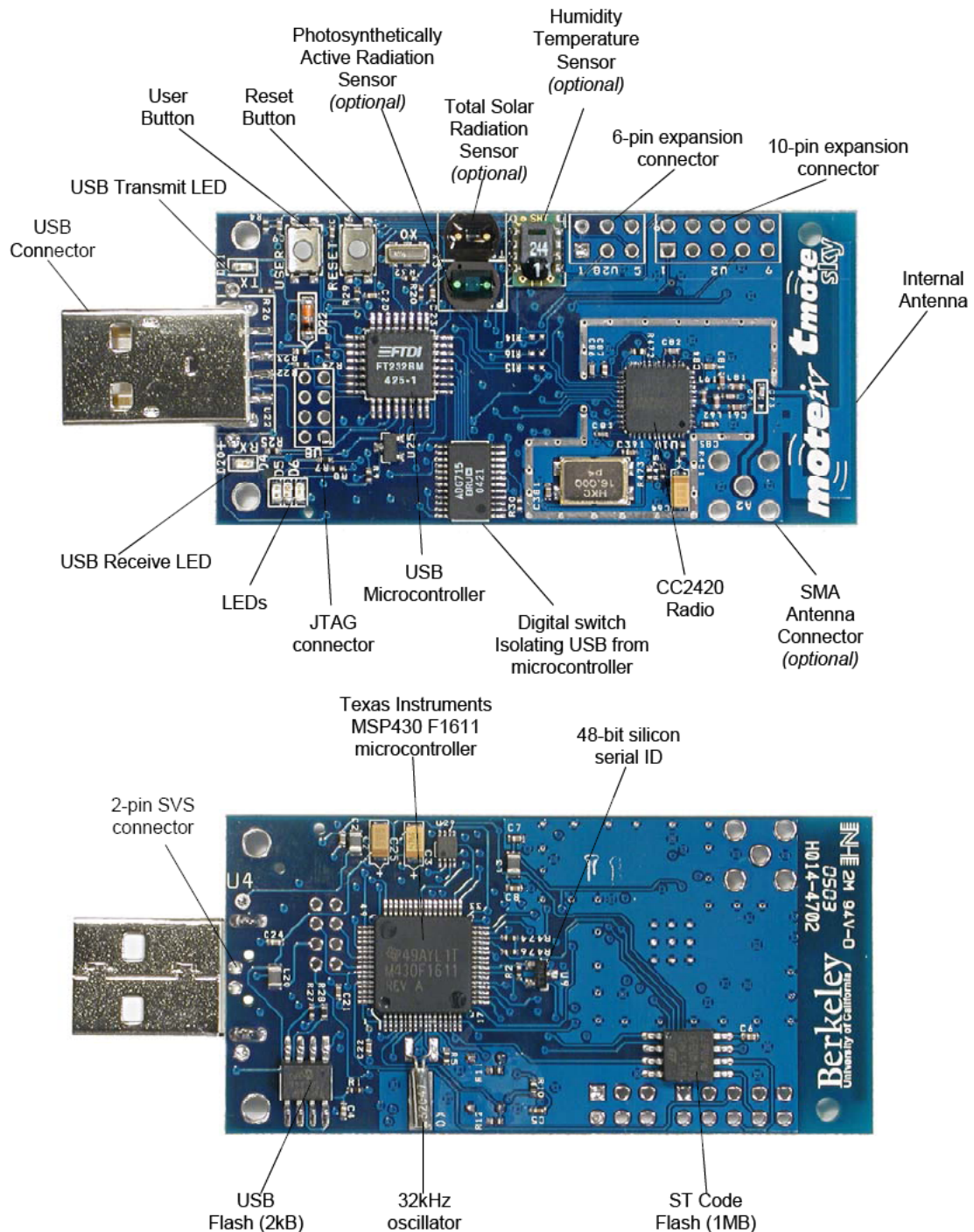

Figure 2. Front and Back of the Tmote Sky module

## 2.3 BTnode

The BTnode [4] is a versatile, autonomous wireless communication and computing platform based on a Bluetooth radio, a second low-power radio and a microcontroller. It serves as a demonstration and prototyping platform for research in mobile and ad-hoc connected networks (MANETs) and distributed sensor networks (WSNs). The BTnode has been jointly developed at the ETH Zurich (Swiss Federal Institute of Technology in Zurich) by the Research Group for Distributed Systems, and the Computer Engineering and Networks Laboratory. Its development had been primarily supported by the NCCR-MICS [5] and the Smart-Its [6] research projects, the latter being a part of the European initiative “The Disappearing Computer”, and funded by both the Commission of the European Union and the Swiss Federal Office for Education and Science.

There have been three major hardware revisions of the BTnode hardware platform: BTnode rev 1, BTnode rev2 and BTnode rev3. The BTnode rev3 is now successfully used in several research projects spanning from rather simple applications with few nodes to large, interactive networking applications. As a software system, the BTnode can run both the BTnut, and the TinyOS operating systems.

**MPU:** The Atmel ATmega128L processor is used, with 64+180 kB SRAM, 128 kB Flash and 4 kB EEPROM.

**Radio:** The BTnode uses a Zeevo ZV4002 single chip (Bluetooth v1.2 certified) radio, which employs adaptive/slow frequency hopping (AFH/SFH) Scatternets with 4 simultaneous Piconets, each having a maximum of 7 slaves. It operates in the 2.4 to 2.483GHz at a maximum data rate of 1Mbits/s. The BTnode has a second Radio, namely the Texas Instrument CC1000 operating in the 433-915 MHz band in general, and in the 868 MHz ISM band in particular. It is the same radio as used on the Mica2 Motes, as discussed below.

**Sensors/actuators:** There are no in-built sensors. Sensing capabilities on the BTnode platform are obtained by connecting single sensors or a sensor board to the appropriate lines of the J1 extension or J2 debug connectors (Molex 1.25mm Wire-to-Board and Hirose DF17 Board-to-Board connectors). The high flexibility of the BTnode platform allows users to add a variety of different sensors, thus enabling easy customization of the platform and prototyping a variety of sensor-based, ubiquitous applications. When adding new sensors to the BTnode, however, the correspondent custom sensor drivers must be implemented by the user. Available sensor boards are the ssmall sensor board from Particle Computer GmbH [7] and the BTsense.

There are two versions of the ssmall sensor board. One version, the ssmall medium sensor board, is equipped with the following sensors: TSL2500 daylight and IR light sensor, manufactured by TAOS (Texas Advanced Optoelectronic Solutions), TC74 temperature sensor (typical accuracy:  $\pm 0.5^{\circ}\text{C}$ ), 2 LEDs (can be replaced by other actuators), MAX8261 OP capacitive microphone (high precision, high linearity), ADXL210 2-axis acceleration sensor,

manufactured by Analog Devices (10g max,  $\pm 40$  mg resolution, responsiveness  $< 1$ ms). It is connected to the BTnode through the USP programming board. The other version, the small full sensor board, is identical to the medium board but features an additional 3 axis acceleration sensor (composition of 2 ADXL210).

The BTsense board can be easily affixed to the side of the BTnode. It features the TC74 temperature sensor (digital, I2C), TSL252R light sensor (analog), AMN1 passive infrared motion sensor and the 7BB-12-9 piezo buzzer. Additional I2C digital sensors, as well as one external analog sensor, can be added to the board.

Actuators can also be easily connected to the BTnode platform through the extension connector J1. For debugging purpose, 4 LEDs are embedded on the BTnode circuit board.

**External interfaces:** The external interfaces include UART, SPI, I2C, GPIO, ADC, standard Molex 1.25mm Wire-to-Board and Hirose DF17 Board-to-Board connectors.

**Wireless programming interface:** Remote wireless (re)programming of nodes is made possible by the existence of two independent radio modules. The Bluetooth radio, for instance, can be used as an unobtrusive programming/debugging and monitoring backchannel, while the Chipcon radio operates as the standard communication channel between nodes.

**Legacy network access:** The BTnode is able to easily interact (through the Bluetooth radio) with other devices like mobile phones or PDAs.

**Protocol development interface:** Open access to configure MAC and Routing algorithm using the JTAG interface to program the MPU, which is directly responsible for writing data bytes to the radio transceivers via the MPUs UARTs. The degree of flexibility is subject to hardware constraints.

**Software and operating system:** It uses BTnut operating system (multithreaded C programming) and TinyOS (NesC programming with contrib/tinybt).

**Energy Sources:** It uses separate switchable supplies for Bluetooth, low-power radio, peripherals, and MPU core. It is powered by an external DC supply 3.8–5 V or 2 AA cells with on/off switch. It is reported to have relatively high power consumption, and provides a battery monitor. The switchable power supply on the BTnode offers direct current access for in-situ profiling of the power consumption of both the radio systems and the microcontroller core under real-life operating conditions. This can be used for detailed performance analysis and the evaluation of the energy-efficiency of various protocols.

**Power Saving Modes:** Sleep modes enable the MPU to shut down unused modules in the thereby saving power. There are various programmable sleep modes allowing the user to tailor the power consumption to the application's requirements. The Bluetooth hardware is, however, optimal in terms of power consumption.

**Memory and storage:** The BTnode on-chip memory consists of 128 kbytes of in-system programmable Flash memory, 4 kbytes EEPROM, and 4 kbytes SRAM. The on-chip SRAM is extended to 64 kbytes through an external 256 kbytes memory module. 180 kbytes out of the remaining 196 of the external SRAM are provided as three data cache memory banks, of 60 kbytes each. The remaining 16 kbytes are unused.

**Cost:** The cost is approx. USD per node, excluding accessories.

**Size:** The size is 58.15 x 33 mm attached to a 2 AA cell battery holder.

**Support and availability:** The BTnode is a well-established prototyping platform and is used in more than 30 research projects. The BTnode website is a rich source of useful information and technical documentation. The active mailing list and an open-source community additionally offer the possibility to pose questions and problems and get assistance from expert BTnode users. Products are available from Art of Technology (contract manufacturer), Zurich, Switzerland, email: [btnode@art-of-technology.ch](mailto:btnode@art-of-technology.ch). The BTnode is a very robust hardware platform, that has been widely used in both research and teaching. Software development tools can be easily installed on top of the Windows, Linux or on Mac OS operating systems and detailed installation guides and tutorials are available from the BTnode website. The BTnode can be programmed in standard C language, when the BTnut system software is installed on top of it, or in NesC, when the TinyOS operating system is used.



Figure 3. BTnode rev3

## 2.4 EyesIFXv2

EyesIFXv2 is a sensor node developed by Infineon for the “Energy-efficient self-organizing and collaborative wireless sensor networks” project EYES (IST-2001-34734) [8]. Infineon has combined EYES baseband hardware with a number of optimized peripheral sets to create a series of chips aimed at specific automotive, industrial and consumer applications. Infineon has recently released a new version of the Eyes node, the EyesIFXv2.1. The components of this new board are almost the same of the older v2.0. Two leds have been added to show

the radio activity. The two node versions have the same radio unit, so they can communicate without problems.

**MPU:** The MSP430F1611 processor is used, with 10 kB on-chip RAM and 48 kB flash/ROM. Additionally, there is a 4Mb Atmel serial EPROM connect via an SPI bus.

**Radio:** The radio is a low power consumption single chip TDA5250 transceiver in the 868–870MHz range, operating with FSK modulation and up to 64 kbps (but typically as low as 19 kbps) half duplex wireless connectivity.

**Sensors/actuators:** The sensor equipment of the EYES platform encompasses a temperature sensor and a light sensor. The temperature sensor is the Model LM61 produced by National Semiconductor Range. The Light Sensor is the Model NSL19-M51 Light Dependant Resistor. Besides the onboard sensors, additional external sensors can be connected by using the extender port provided by the platform. To display status information, an array of 4 LEDs is available (in v2.1 there are 6 leds available). In addition, there is an expansion port that allows the connection of secondary boards with additional analog/digital sensors and actuators.

**External interfaces:** External data interfacing is possible through a USB or JTAG interface, which enables programming of the microcontroller and in-circuit debugging. In addition, there is an expansion port that allows the connection of secondary sensors/actuator boards or measurement instruments (e.g., logic analyzer). This connector provides access to the SPI 3-wire bus. Additionally, the RSSI analog level from TDA5250 can be measured and an external voltage reference for the A/D converter can be provided. Finally some bits from the MSP430 ports can be accessed for I/O operations.

**Wireless programming interface:** Remote wireless (re)programming of nodes is possible through the USB interface which may be connected to a wireless USB card for Bluetooth or other standard.

**Legacy network access:** Communication over different wireless networks may be enabled using wireless USB devices connected to the USB interface.

**Applications:** The EYES platform is targeted at extremely low-powered, low-data rate applications in demanding RF environments where robustness to noise and interference are essential.

**Protocol development interface:** The EYES nodes are fully programmable (through the USB or JTAG interface), so that users can design and develop customized functional blocks, such as MAC, routing and so on. Nevertheless, a very essential protocol stack is provided by Infineon and TinyOS for beginners. The stack includes an implementation of Carrier Sense Multiple Access (CSMA) for MAC.

**Software and operating system:** It uses TinyOS with NesC.

**Energy Sources:** The nodes run on lithium batteries with a capacity of 1000mAh. Alternatively, there is an external power connector to supply DC current as well as a USB port that can power the node.

**Power Saving Modes:** Eyes uses the low-power consumption MSP430 (as discussed in Section 2.1), as well as the low power consumption TDA5250. In comparison to earlier used ISM transceivers for TinyOS applications, the TDA5250 has lower power consumption. In transmit mode it needs only 12 mA; while receiving 9 mA are sufficient. For this reason, the transceiver is particularly suitable for battery-operated applications requiring very long operating times.

**Memory and storage:** The memory/storage capability is based on the on-board MSP430 microcontroller's 10 kB RAM and 48 kB flash/ROM and the 4Mb Atmel external serial EPROM.

**Cost:** The cost is approx. 70 Euros per node, excluding accessories.

**Size:** The size is 3.2 cm by 6.55 cm by 0.66 cm.

**Support and availability:** Documentation can be downloaded, free of charge, from Infineon website [9]. Additional information can also be found in the website of the academic research groups that are using the platform for experimentation, such as Twente University (Netherlands), Technical University of Berlin (Germany), CINI (Italy), and University of Padova (Italy).

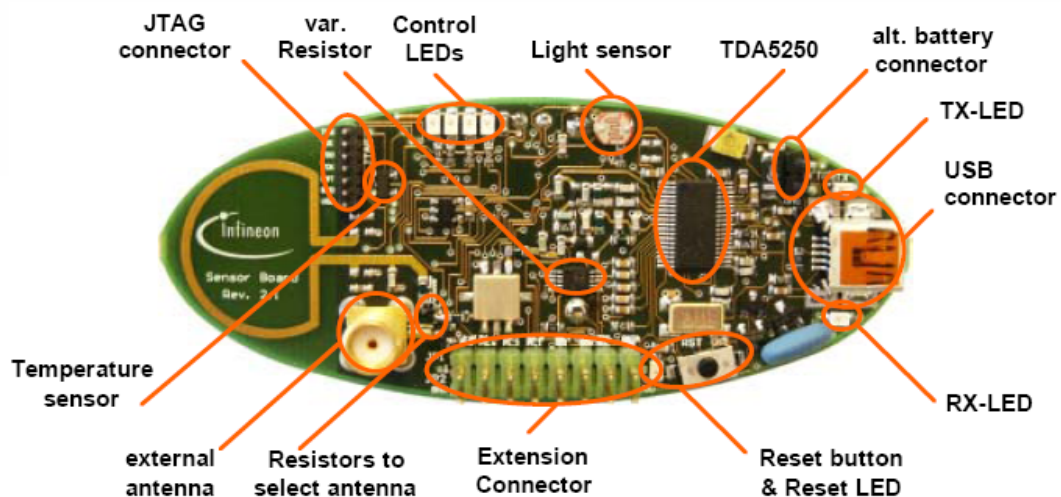

Figure 4. Top side of the node

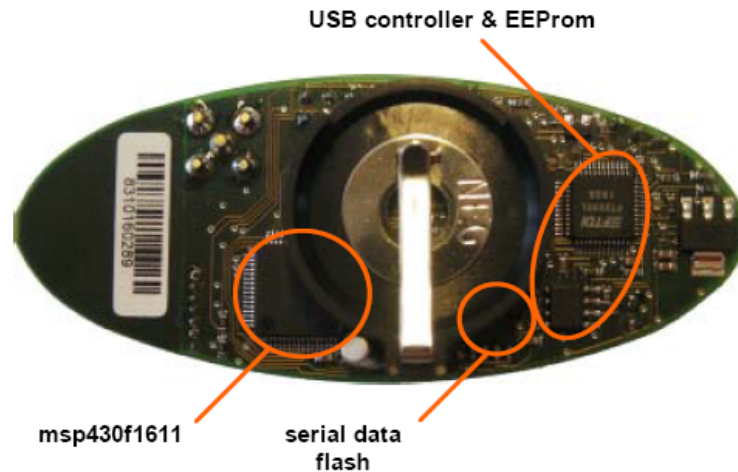

Figure 5. Bottom side of the node

## 2.5 MICAz Mote

Crossbow [10] ships three MICA Mote Processor/Radio module families – MICAz (MPR2400), MICA2 (MPR400), and MICA2DOT (MPR500). The MICAz radio works on the global 2.4GHz ISM band and supports IEEE802.15.4 and ZigBee.

**MPU:** The Atmel ATmega128L processor is used, with 128 kB of Flash, 4 kB of SRAM and External serial flash memory (512 kB).

**Radio:** The radio is a Texas Instrument CC2420 which is IEEE 802.15.4 (ZigBee) compliant operating at 2.4 to 2.48 GHz, with 250 kbps data rate.

**Sensors/actuators:** Crossbow offers a variety of sensor and data acquisition boards for the MICAz Mote. All of these boards connect to the MICAz via the standard 51-pin expansion connector. Custom sensor and data acquisition boards are also available. No in-built sensors. It also has 3 programmable LEDs.

**External interfaces:** External data interfacing is possible through 2 UARTs (Universal Asynchronous Receive and Transmit), Serial Port Interface (SPI) bus, Dedicated hardware I2C bus, 51-pin expansion connector, analog/digital I/O interfaces and a JTAG port.

**Wireless programming interface:** Remote wireless (re)programming of nodes is possible through the base station, which any MICAz Mote can function as by plugging the processor/radio board into a Crossbow MIB510CA serial interface board. The MIB510CA provides an RS-232 serial interface for both programming and data communications.

**Legacy network access:** Communication over different wireless networks may be enabled using the base station to connect to a PC, which may be enabled with an interface to any other network.

**Applications:** Applications include indoor building monitoring and security, and acoustic, video, Vibration, and other high speed sensor data collection. Large scale sensor networks (1000+ Points) possible.

**Protocol development interface:** MICAz is equipped with a standard 802.15.4 protocol compatible transceiver and offers limited flexibility for proprietary protocol development.

**Software and operating system:** It uses TinyOS with NesC.

**Energy Sources:** The nodes are powered by two AA batteries.

**Power Saving Modes:** Combines the power saving features of the ATmega128L MPU and the CC2420 transceiver as discussed in section 2.3 and section 2.2, respectively.

**Memory and storage:** The memory/storage capability includes the on-board MPU's 128 kB of Flash, 4 kB of SRAM and external serial flash memory (512 kB).

**Cost:** The cost is approx. 100 Euros per node, excluding accessories.

**Size:** The size is 58 x 32 x 7 mm.

**Support and availability:** Documentation and support from Crossbow website and contacts.

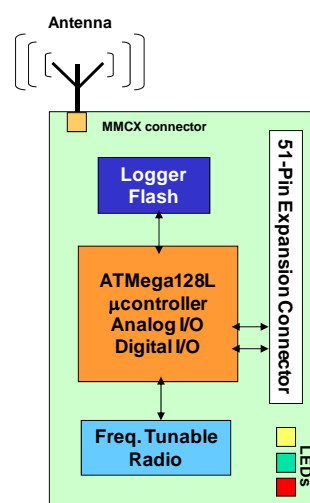
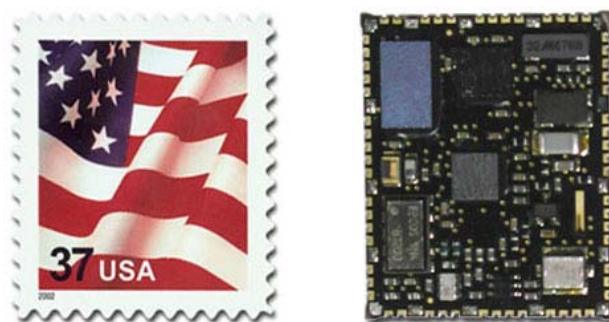

Figure 6. MicaZ



## 2.6 MICA2 Mote

The MICA2 is available in 868/900MHz multichannel configurations and supports frequency agile operation. Crossbow's Mica2 is similar to MicaZ, except that it uses a different radio: Texas Instruments CC1000 that operates at 868/900MHz with 38.4 kbps data rate. Thus it is used for lower data rate applications. There is also explicit support for wireless remote programming.

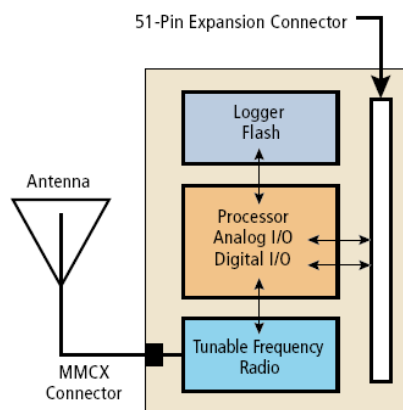

Figure 7. Mica2

## 2.7 MICA2DOT Mote

The MICA2DOT is available in 868/916 MHz, 433 MHz or 315 MHz multi-channel operation (MICA2 Compatible) with 38.4 kbps data rate and supports frequency agile operation. The Mica2Dot differs from Mica2 in its size (25 x 6 mm) and different transceiver with multiple channel operation. Its small size makes it suitable for active “two-way” smart tags, smart badges and wearable computing. It has 18-pin expansion connectors, as opposed to the 51-pins of Mica2 and MicaZ.

## 2.8 Imote2

The Imote2 is built around the low-power PXA271 XScale CPU and also integrates an 802.15.4 compliant radio. The design is modular and stackable with interface connectors for expansion boards on both the top and bottom sides. The top connectors provide a standard set of I/O signals for basic expansion boards. The bottom connectors provide additional high-speed interfaces for application specific I/O. A battery board supplying system power can be connected to either side.

**MPU:** The Marvell PXA271 CPU can operate in a low voltage (0.85V), low frequency (13MHz) mode, hence enabling very low power operation. The PXA271 is a multichip module that includes three chips in a single package, the CPU with 256kB SRAM, 32MB SDRAM and 32MB of FLASH memory. The PXA271 includes a wireless MMX coprocessor to accelerate multimedia operations. It adds 30 new media processor (DSP) instructions, support for alignment and video operations.

**Radio:** The Imote2 uses the CC2420 IEEE 802.15.4 radio transceiver from Texas Instruments. The CC2420 supports a 250kb/s data rate with 16 channels in the 2.4GHz band. Other radio options will be enabled through SDIO cards and UART/USB.

**Sensors/actuators:** No onboard sensors but sensor boards available.

**External interfaces:** The CPU integrates many I/O options making it extremely flexible in supporting different sensors, A/Ds, radios, etc. These I/O features include I2C, 2 Synchronous Serial Ports (SPI) one of which is dedicated to the radio, 3 high speed UARTs, GPIOs, SDIO, USB client and host, AC97 and I2S audio codec interfaces, fast infrared port, PWM, a Camera Interface and a high speed bus (Mobile Scaleable Link).

**Wireless programming interface:** Remote wireless (re)programming of nodes is possible through SDIO cards and UART/USB interfaces, which enable additional radio options to be included.

**Legacy network access:** Communication over different networks may be enabled using SDIO cards and UART/USB interfaces.

**Applications:** Applications include digital image processing, condition based maintenance, industrial monitoring and analysis, and seismic and vibration monitoring.

**Protocol development interface:** The use of an 802.15.4 compliant transceiver limits the flexibility of protocol development when using the primary transceiver. However, the possibility to attach other transceiver devices via the SDIO and UART/USB interfaces, allows protocol development using these secondary radios.

**Software and operating system:** It uses TinyOS, Linux, SOS, and a range of other operating systems and associated programming tools.

**Energy Sources:** Crossbow Imote2 Battery Board connected to either the basic or advanced connectors, rechargeable Li-Ion or Li-Poly batteries with a built-in charger, mini-B USB connector (also for charging an attached battery) and a suitable primary battery or other power source can be connected via a dedicated set of solder battery pads on the Imote2 board.

**Power Saving Modes:** Imote2's Intel PXA271 CPU can operate in a low voltage (0.85V), low frequency (13MHz) mode, hence enabling very low power operation. It has a number of different low power modes such as sleep and deep sleep.

**Memory and storage:** The memory/storage capability includes the on-board MPU's memories (256kB SRAM, 32MB SDRAM and 32MB of FLASH memory) and extendable memory/storage through the SDIO and USB interfaces.

**Cost:** The cost is approx. 100 Euros per node, excluding accessories.

**Size:** The size is 36mm x 48mm x 9mm.

**Support and availability:** Documentation and support from Crossbow website and contacts.

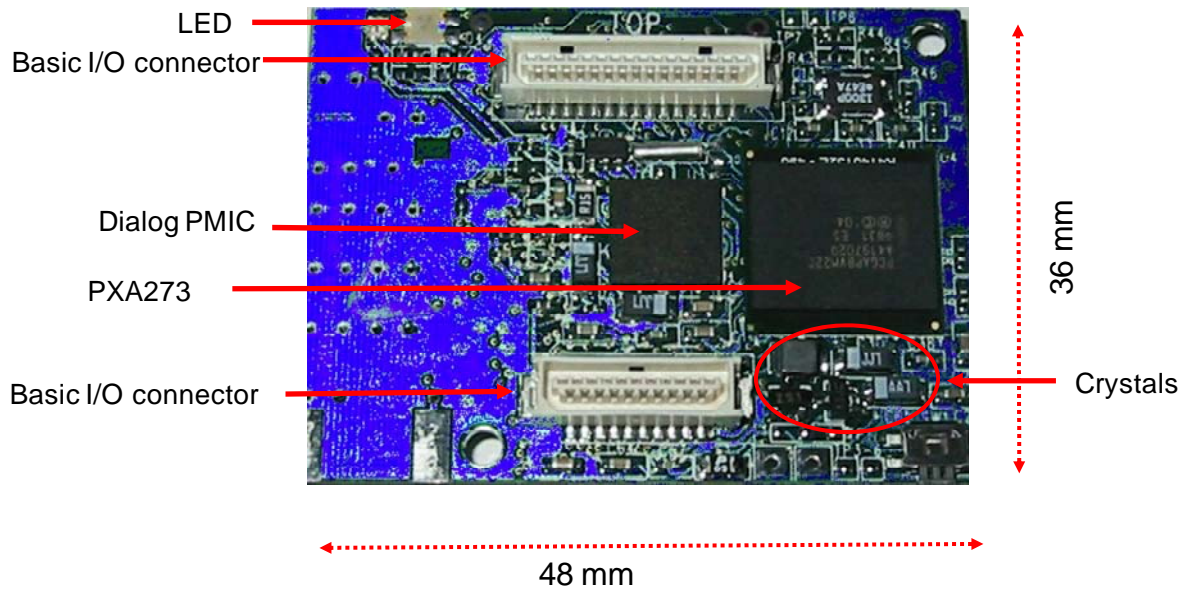

Figure 8. Imote2 (top view)

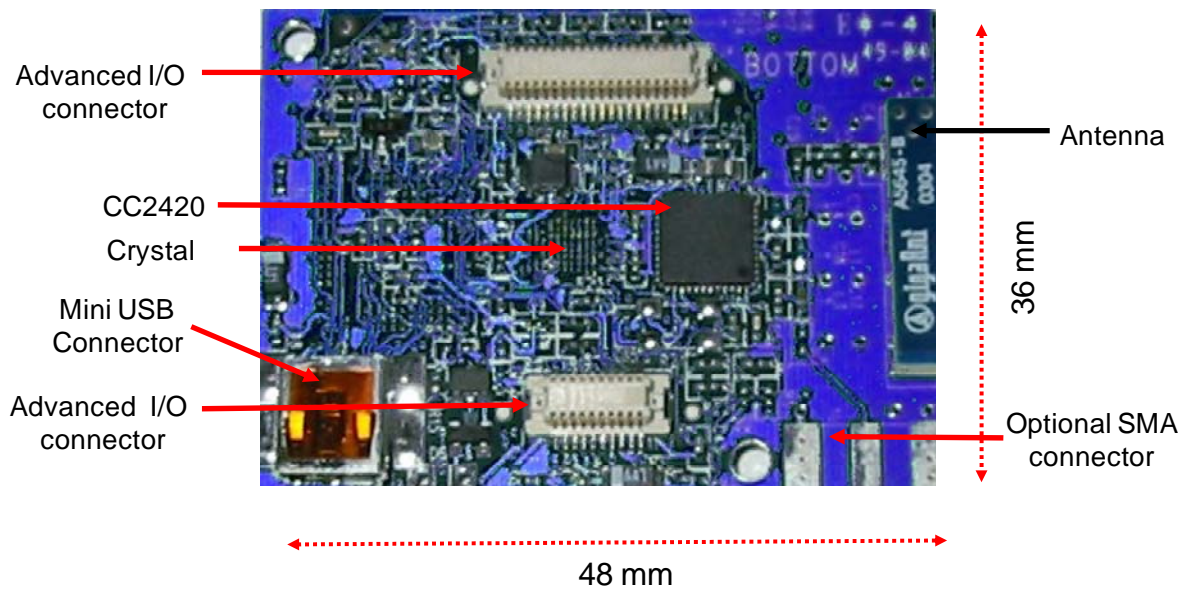

Figure 9. Imote2 (bottom view)

## 2.9 Summary

Table 1 and Table 2 summarise key features of the sensor node platforms. The Imote2, Mica family of motes (Micaz, Mica2 and Mica2dot) and the BTnode offer the most flexible platforms of the state-of-the-art. Furthermore, they offer the advantage of experience from several deployments and support from manufacturers and other users.

	Platform		
<b>Features</b>	MSB430	Tmote Sky	BTnode
<b>MPU@[MHz]</b>	MSP430F1612IPM@11	MSP430 F1611@8	ATmega128L@8
<b>MPU Memory</b>	55 kB Flash, 5 kB RAM	48 kB Flash, 10 kB RAM	128 kB Flash, 64+180 kB SRAM and 4 kB EEPROM
<b>Radio</b>	TI CC1020	TI CC2420 (IEEE 802.15.4)	Zeevo ZV4002 (Bluetooth 1.2), TI CC1000
<b>Freq. Band [MHz]</b>	402 – 470, 804 - 940	2400-2483	2400-2483 (ZV4002) 433-915 (CC1000)
<b>Data Rate [kbs]</b>	153.6 (19 typical)	250	1000 (ZV4002), 76.8 (CC1000)
<b>Software</b>	C/SactterWeb OS, NesC/TinyOS	NesC/TinyOS	C/BTnut OS, NesC/TinyOS
<b>Support Rating</b>	3/5	2/5	4/5
<b>Development Interface</b>	Open access	Constrained access	Open access
<b>Remote Programming</b>	Via wireless USB cards and gateway (in-band)	Via wireless USB cards and gateway (out-of-band)	Via in-built secondary radio (e.g. Bluetooth)
<b>Size [cm]</b>	3.6x4.1	3.2x6.55x0.66	5.8x3.3

Table 1. Summary of features of sensor node platforms – part 1

	Platform				
<b>Features</b>	EyesIFXv2	MICAz	MICA2	MICA2DOT	Imote2
<b>MPU@[MHz]</b>	MSP430 F1611@8	ATmega128L @8	ATmega128L @8	ATmega128L @8	IPXA271@13 – 416MHz
<b>MPU Memory</b>	48 kB Flash, 10 kB RAM	128+512 kB Flash, 4 kB SRAM	128+512 kB Flash, 4kB SRAM, 4 kB EEPROM	128+512 kB Flash, 4kB SRAM, 4 kB EEPROM	32MB Flash, 256kB SRAM, 32 MB SDRAM
<b>Radio</b>	TDA5250	TI CC2420 (IEEE 802.15.4)	TI CC1000	TI CC1000	TI CC2420 (IEEE 802.15.4)
<b>Freq. Band [MHz]</b>	868–870	2400-2483	868-916 (spectral-agile)	868-916, 433 or 315 (spectral-agile)	2400-2483
<b>Data Rate [kbs]</b>	64	250	38.4	38.4	250
<b>Software</b>	NesC/TinyOS	MoteWorks (TinyOS based)	MoteWorks (TinyOS based)	MoteWorks (TinyOS based)	TinyOS, Linux, SOS
<b>Support Rating</b>	3/5	5/5	5/5	5/5	5/5
<b>Development Interface</b>	Open access	Constrained access	Constrained access	Constrained access	Open access with add-on transceivers
<b>Remote Programming</b>	Via wireless USB cards and gateway	Via 802.15.4 gateway	Via gateway	Via gateway	Via wireless cards and gateway
<b>Size [cm]</b>	3.2x6.55x0.7	5.8x3.2x0.7	5.8x3.2x0.7	2.5x0.6	3.6x4.8x0.9

Table 2. Summary of features of sensor node platforms— part 2

The BTnode has the advantage over the Mica family of allowing more flexible custom protocol development. The Imote2 and Mica family have the advantage over the BTnode of guaranteed support from Crossbow. Imote2 offers a more power efficient processor than the Mica range, and flexibility to incorporate multiple radio operations, while having a default 802.15.4 compliant radio. Both Imote2 and the Mica family are deemed more power efficient than the BTnode.

### 3 State-of-the-Art in WSN Testbeds

The aim of this section is to provide the reader with a short survey on existing testbeds of academic institutions in the UK, EU and USA based on the information available on the Internet. The survey is not exhaustive. It rather gives a broad overview of the current status of wireless sensor network (WSN) testbeds in terms of (when available):

- Scope and size, devices used,
- Key functions, architecture, software,
- Wireless technologies used,
- Department, director.

#### 3.1 Institutes in the UK and Europe

The Wireless Sensor Network Research Laboratory of the University of Surrey hosts a state-of-the-art experimental research facility for WSN, which is used for the prototyping and evaluation of developed protocol solutions [11]. The WSN testbed serves as a basis for the development of novel mobile, context-aware services and applications. The testbed consists of wireless sensor nodes that can be organised in different network topologies and individually configured for various experiments. It uses the backbone infrastructure of a larger wireless network testbed. The testbed also includes servers and mobile devices, some of which serving as mobile gateways. There are 70 SensiNode Micro.2420 and 5 SensiNode Nano.2430 motes equipped with 802.15.4 radio in the testbed. There are 15 prototyping boards for these nodes and also 2 body sensor networks, with their own development kit, to be integrated to the system.

The University of Surrey was also a member of the EU-FP6-IST integrated project called e-SENSE [12] together with Fujitsu, Thales, King's College London from the UK and several other European universities such as Aalborg/Denmark, Aegean/Greece, TU Delft/Holland, Twente/Holland, ETH Zurich/Switzerland. The main objective of the e-SENSE project is to contribute to the evolution and definition of the future ambient intelligent mobile systems and platforms within the context of Beyond 3G by integrating ubiquitous WSN into Beyond 3G. WSN will capture the ambient intelligence surrounding mobile users. Testbeds are envisioned to validate the e-SENSE approach and it can be concluded from the project deliverables that the University of Surrey testbed was actively used in this project. Besides the e-SENSE project, the EU-FP7-IST Network of Excellence (NoE) project CRUISE intends to be a focal point in the planning and coordination of research on communication and

application aspects of wireless sensor networking in Europe [13]. CRUISE stands for "Creating Ubiquitous Intelligent Sensing Environments" and envisions among other issues also the integration of existing testbeds to open them within the NoE for joint experiments.

The Technical University of Berlin Telecommunication Networks Group headed by Adam Wolisz has a wireless indoor sensor network testbed called TWIST [14]. The hierarchical architecture of the testbed enabling users easy access to the motes and increasing the efficiency in reprogramming them as well as in reconfiguring the sensor network is also proposed by the same group. According to the proposed hierarchy, there are three tiers in the network architecture: The main server on the top tier is connected through Ethernet to microservers on the middle tier. The microservers are connected through USB to the motes on the bottom tier. No details are given on the size and capacity of the WSN testbed TWIST. However, cooperation with UC Berkeley (PicoRadio), Infineon Technologies (eyesIFX sensor network development kit), Mote IV (Telos), Texas Instruments and National Instruments are mentioned. In addition, the Washington University in St. Louis also has a testbed based on the TWIST architecture of TU Berlin.

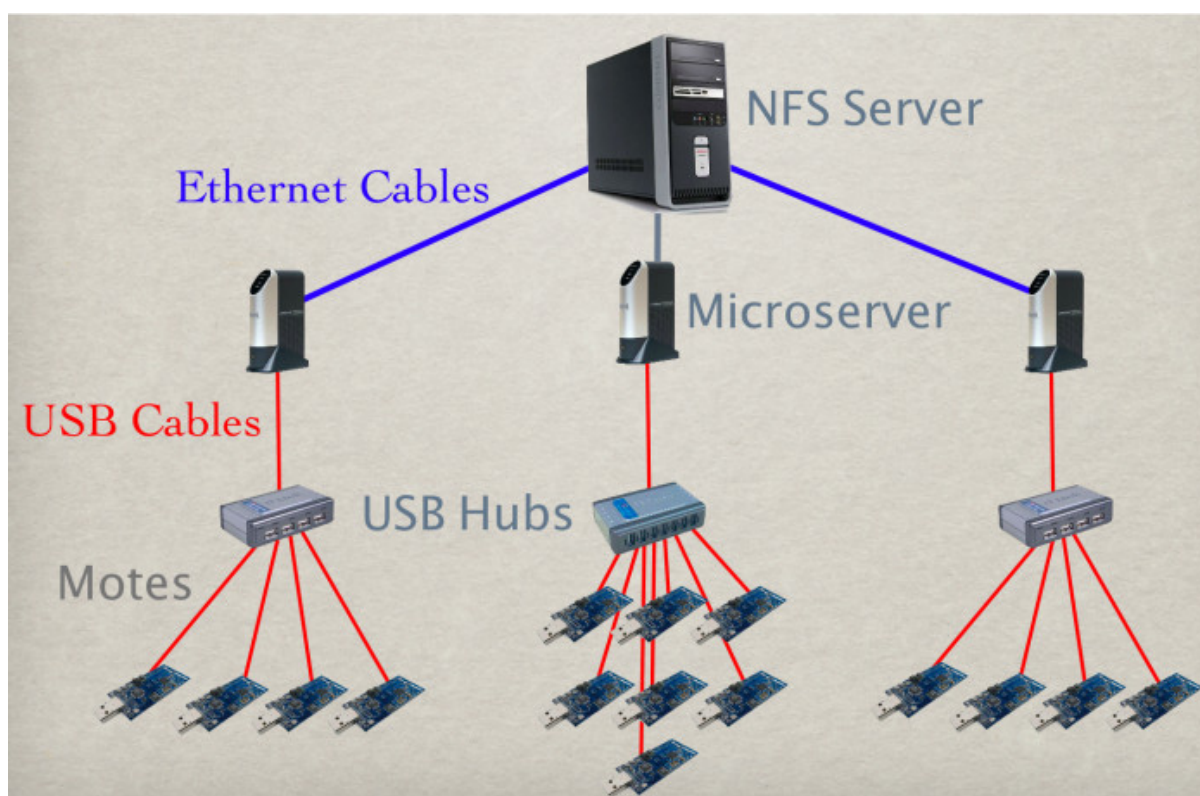

Figure 10. The TWIST Architecture of TU Berlin.

### 3.2 Institutions in the USA

Until recently, the research activities on WSN have been relatively more intensive in the USA than in Europe. As a result of this, there are quite a number of academic institutes that have developed an experimental testbed as part of their research. Some of these testbeds are summarised below.

The Clustered Computing Group of the Engineering Research Support Organisation, UC Berkeley, maintains general purpose computing cluster environments, which are open to researchers within the university community [15]. The WSN testbeds of the university are maintained by this group, although the main users are from the Wireless Embedded Systems Research Centre headed by David E. Culler from the Department of Electrical Engineering and Computer Sciences. For the development and testing of WSN applications, two permanent in-building testbeds are deployed in the computer science building. The aim of these testbeds is to facilitate research in programming environments, communication protocols, system design and applications. The first of these testbeds is called MOTESCOPE. It consists of 78 MICAz motes from Atmel (ATmega 128L) with a wireless transmission range of 20-30 m. There are plans to add IP-connected Telos motes to the testbed in the near future. The second indoor testbed is known as OMEGA. It comprises 28 Telos motes from Texas Instruments with 802.15.4 wireless transceivers from Chipcon. The motes are connected to a server via USB for power, programming and debugging purposes. In addition to these, UC Berkeley also has a testbed deployed in the campus field, which is called TRIO and has more than 500 Trio motes. The nodes of these testbeds run the TinyOS operating system and can be programmed in NesC. Applications can be simulated using TOSSIM or prototyped with a few motes on the user's desktop. The sMote web interface is used by researchers and students to upload software to the testbed.

MoteLab is an experimental wireless sensor network deployed by Maxwell Dworkin Laboratory, Department of Electrical Engineering and Computer Science, Harvard University [16]. It provides a public, permanent testbed for development and testing of sensor network applications via an intuitive web-based interface. Registered users can upload executables, associate those executables with motes to create a job, and schedule the job to be run on MoteLab. The aim of MoteLab is similar to that of UC Berkeley. There are 190 TMote Sky sensors for light, temperature and humidity in the testbed. The motes are wall-powered and do not contain any batteries. The wireless communication module of the motes is from Chipcon with an indoor coverage of 100 m. Ethernet connection is used for the debugging and reprogramming of the motes. The usage scheme is also similar to that of Berkeley, which means that only users within Harvard University are provided with access. Harvard University also has an urban-scale WSN testbed with 100 nodes made of Linux-based embedded PCs, which is part of their CitySense project.

The Georgia Institute of Technology, School of Electrical and Computer Engineering, Broadband Wireless Networking Laboratory headed by Ian Akyildiz runs a wireless multimedia sensor network project [17] funded by the National Science Foundation (NSF). As part of this project, the research group deploys an experimental testbed based on currently-off-the-shelf advanced devices to demonstrate the efficiency of their self-developed algorithms and protocols for multimedia communications through WSN. The testbed comprises scalar sensors from MICAz, Cyclops cameras for low-end imaging, Logitech webcams for medium-quality multimedia sensors and high-end pan-tilt video

cameras mounted on robots with 802.11 and 802.15.4 communication capabilities. The robots act as a mobile sinks and can move to the area of interest for closer visual inspection. The objective is to develop a high-quality mobile platform that can perform adaptive sampling based on event features detected by low-end motes. The mobile actor can redirect high-resolution cameras to a region of interest when events are detected by lower-tier, low-resolution video sensors that are densely deployed. Currently, the testbed consists of 6 imotes from Intel and 50 MICAz from Crossbow. The group plans to increase the number of MICAz sensors in order to deploy a higher-scale testbed that allows testing more complex algorithms and assess the scalability of the communication protocols under examination.

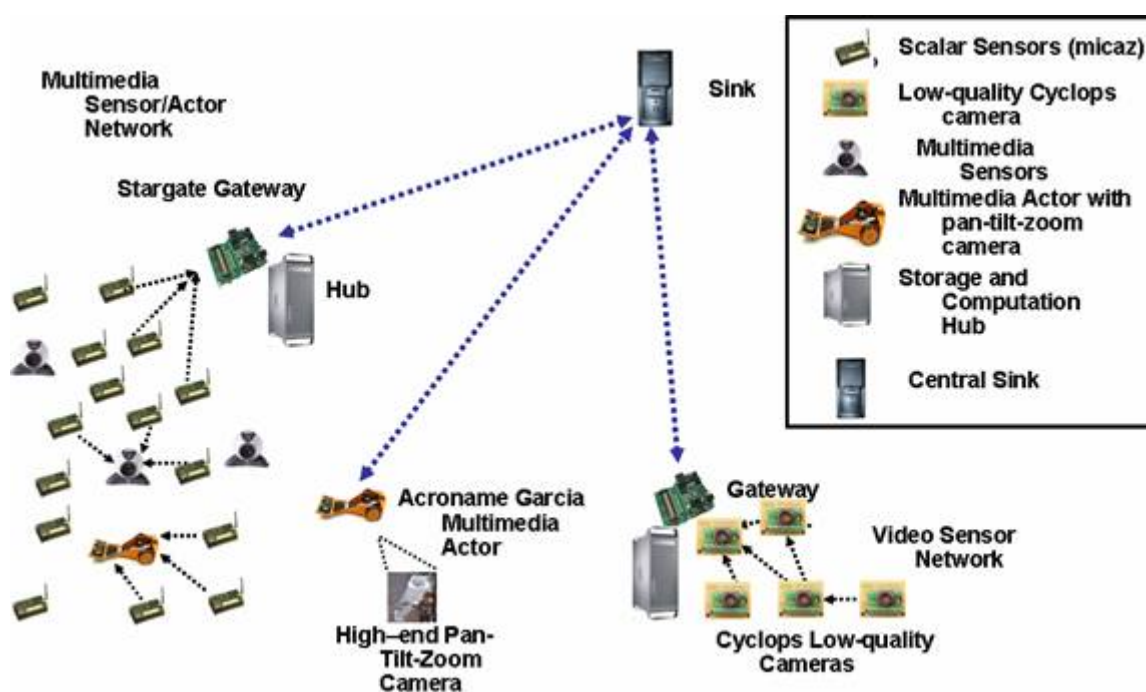

Figure 11. The Wireless Multimedia Sensor Network Testbed of Georgia Tech.

The KANSEI sensor testbed, managed by Anish Arora, is deployed by the Center for Enterprise Transformation and Innovation, Department of Computer Science and Engineering, Ohio State University [18]. The aim of the project is to develop a heterogeneous testbed with multiple communication networks and a reconfigurable, extensible, modular physical and topological architecture. The testbed was initially part of Extreme Scale (ExScal) Wireless Sensor Networking project to address the scalability issues in WSN funded by DARPA. There are 210 extreme scale motes (XSM) connected individually to 210 extreme scale Stargates (XSS) in the testbed. The motes build a physical grid structure. In order to achieve an out-of-band signalling channel for the instrumentation and configuration of experiments, Stargates are connected using wired Ethernet and wireless 802.11 network technologies. The infrastructure also allows the users to conduct experiments with 802.11b networking and XSMs. Experiment scheduling is made possible for users through a web interface.



The University of Southern California, Computer Science Department, Embedded Networks Laboratory, headed by Ramesh Govindan, owns a tiered WSN testbed called TUTORNET [19]. The network topology consists of 13 clusters with one Stargate as the head of each cluster. The Stargates communicate with a central testbed server over 802.11b, from where any node on the testbed can be programmed. They also contain a 7-port USB hub and an Orinoco Classic Gold PC card. A total of 104 motes (91 Tmote Sky and 13 MICAz) are attached via USB to the Stargate nodes. Thus, the testbed contains three tiers of hierarchy. The programming environment is comprised of Linux, TinyOS and NesC. The group has several ongoing WSN projects, where the TUTORNET testbed is used.

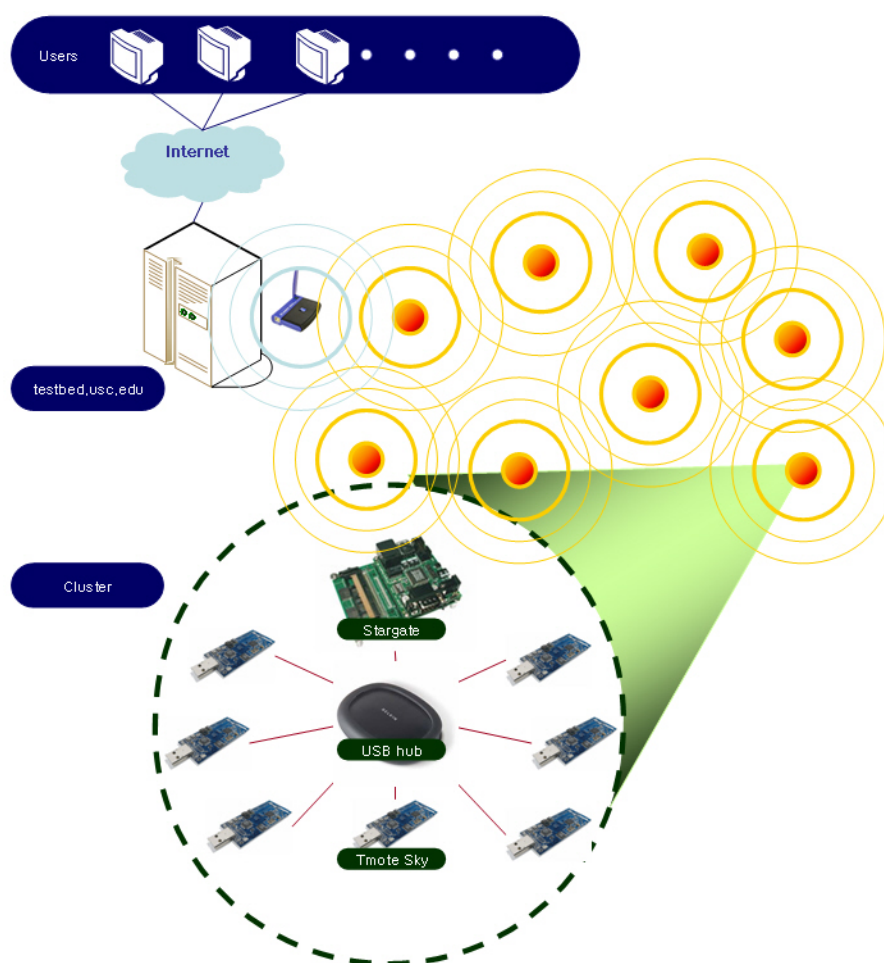

Figure 12. The TUTORNET Testbed Architecture of USC.

### 3.3 Summary

The design, implementation and evaluation of WSN applications and protocols is not an easy task due to their limitations on size, energy, processing capability as well as their distributed nature. Although initial design efforts can be conducted using simulations, this forces the designer to use an oversimplified version of the environment that the application will be running in. Therefore, much more realistic development and test conditions are essential as soon as the preliminary phase of the WSN design is completed. These conditions can only be provided using real hardware, realistic environments and realistic experimental setups.

The aim of our research group is to build a WSN testbed that meets the requirements mentioned above. We intend to investigate further the devices summarised in this survey and select the hardware corresponding to our design requirements listed in the appendix. We also intend to adapt a complementary approach to other well-known WSN testbeds, which are summarised in this report. The architecture of our testbed will naturally benefit from past experience within the UCL. Currently, the UCL computer science department has a testbed of 50 Sentilla Tmotes connected to a Tmote gateway. Based on our requirements, however, we need to design and build our own testbed, which will enable us to develop and test efficient and reliable medium access control and routing protocols for WSN.

## 4 References

- [1] <http://www.scatterweb.com>
- [2] <http://www.moteiv.com>
- [3] <http://www.sentilla.com>
- [4] <http://www.btnode.ethz.ch>
- [5] <http://www.mics.org>
- [6] <http://www.smart-its.org>
- [7] <http://www.particle-computer.net>
- [8] <http://www.eyes.eu.org>
- [9] <http://www.infineon.com>
- [10] <http://www.xbow.com>
- [11] [http://www.ee.surrey.ac.uk/CCSR/facilities/mobile/wsn/wsn\\_testbed.html](http://www.ee.surrey.ac.uk/CCSR/facilities/mobile/wsn/wsn_testbed.html)
- [12] <http://www.ist-esense.org/index.php?id=48>
- [13] <http://www.ist-cruise.eu/cruise>
- [14] <https://wg.tkn.tu-berlin.de/twiki/bin/view/TWIST/WebHome>
- [15] <http://www.millennium.berkeley.edu/sensornets>
- [16] <http://motelab.eecs.harvard.edu/index.php>
- [17] <http://www.ece.gatech.edu/research/labs/bwn/WMSN/index.html>
- [18] <http://ceti.cse.ohio-state.edu/kansei/index.php?page=main>
- [19] <http://enl.usc.edu/projects/tutornet/index.html>

## **Appendix:**

### **Technical Requirements of the UCL/AIRBUS Wireless Sensor Network Testbed**

This section is organised according to the phases of application development for WSN. It also includes some of the management aspects.

#### **Design and Implementation**

- Flexible support of different network topologies, in order to emulate dynamic and arbitrary changes in topology resulting from node failure and dynamic channel propagation conditions from in flight weather conditions.
- Advanced power management features to enable innovative, energy efficient network and MAC protocol development and testing.
- Modular nodes with replaceable processing, communication, sensing and power units to emulate the diverse range of capabilities of the devices of the AIRBUS sensor/actuator network.
- Local data processing capability for distributed open-loop control algorithms as required for real-time flow control.
- Ease of development on network and MAC layers including cross-layer approaches.
- Remote (re)programming/debugging. This enables mass configuration of the network, as well as facilitates the easy debugging of individual nodes in hard-to-reach locations in real aircraft deployments.
- Time synchronisation between nodes to setup controlled experiments.

#### **Experimenting and Validation**

- Flexibility in generating the different traffic patterns that result from the sensed physical parameters of the air-flow field, such as pressure, turbulence, temperature, and speed.
- Easy implementation of in-flight channel propagation and interference conditions.
- Remote individual and mass control of nodes to emulate node failure.
- Battery monitoring.