



LUND UNIVERSITY

Solar Collectors Combined with Ground-Source Heat Pumps in Dwellings - Analyses of System Performance

Kjellsson, Elisabeth

2009

[Link to publication](#)

Citation for published version (APA):

Kjellsson, E. (2009). *Solar Collectors Combined with Ground-Source Heat Pumps in Dwellings - Analyses of System Performance*. [Doctoral Thesis (monograph), Division of Building Physics]. Byggnadsfysik LTH, Lunds Tekniska Högskola.

Total number of authors:

1

General rights

Unless other specific re-use rights are stated the following general rights apply:

Copyright and moral rights for the publications made accessible in the public portal are retained by the authors and/or other copyright owners and it is a condition of accessing publications that users recognise and abide by the legal requirements associated with these rights.

- Users may download and print one copy of any publication from the public portal for the purpose of private study or research.
- You may not further distribute the material or use it for any profit-making activity or commercial gain
- You may freely distribute the URL identifying the publication in the public portal

Read more about Creative commons licenses: <https://creativecommons.org/licenses/>

Take down policy

If you believe that this document breaches copyright please contact us providing details, and we will remove access to the work immediately and investigate your claim.

LUND UNIVERSITY

PO Box 117
221 00 Lund
+46 46-222 00 00

Solar Collectors Combined with Ground-Source Heat Pumps in Dwellings

Analyses of System Performance

Elisabeth Kjellsson

Report TVBH-1018 Lund 2009
Building Physics LTH



LUND
UNIVERSITY

Solar Collectors Combined with Ground-Source Heat Pumps in Dwellings

Analyses of System Performance

Elisabeth Kjellsson

Doctoral Thesis

Building Physics LTH
Lund University
Box 118
S-221 00 Lund
Sweden

ISRN LUTVDG/TVBH--09/1018--SE(160)
ISSN 0349-4950
ISBN 978-91-88722-40-9
©2009 Elisabeth Kjellsson

*“You better live your best
and act your best
and think your best today,
for today is the sure preparation
for tomorrow and all the other tomorrows that follow.”*

Harriet Martineau

Preface

This report includes results from simulation work regarding the combination of solar collectors and ground source heat pumps in single family dwellings. The presented results are mainly produced within one project, but in the background there are results from earlier projects regarding solar energy, ground coupled heat pumps and energy efficiency in buildings. These are projects that I have been working with during my time at the Department of Building Physics at Lund University. My interest for solar energy has been strong since the beginning of the '80s, when I had the pleasure to work with the realization of a large solar collector plant with seasonal storage, at that time working for Uppsala Kraftvärme AB (The Combined Power and District Heating Company in Uppsala, Sweden).

My first supervisor and source of inspiration in Lund, was the former professor in Building Physics at Lund University, Arne Elmroth. Later on Göran Hellström (professor in Renewable Energy, Luleå Technical University), international expert in utilization of ground heat, took over the supervision together with professor Björn Karlsson (professor in Solar Energy Technique, Lund University) and Bengt Perers, researcher at that time in Lund University, now in Technical University of Denmark. They have all been important for the progress of my work and especially Bengt Perers have been very active in supporting the work of developing the simulation deck. Also my colleagues at the Department of Buildings Physics have given support of all kind, especially: Professor Jesper Arfvidsson, everlasting encouraging and problem solving, Birgitta Salmi, taking care of all economical matters and Lilian Johansson, excellent drawings and printing support. I will also thank all others that have come with valuable comments and support.

This work should not been possible without the grant from the Swedish Research Council Formas, who have financed the project. A first part was reported with a licentiate report in 2004, "Solar Heating in Dwellings with Analysis of Combined Solar Collectors and Ground-Source Heat Pump" (in Swedish). Special thanks to Björn Sellberg at Formas, who has been the helpful administrative officer.

Finally, thank you all who have helped and inspired me, and especially to my beloved family Thomas, Mårten, Love and Ludde.

Lund in August 2009

Elisabeth Kjellsson

Abstract

The use of ground-source heat pumps for heating buildings and domestic hot water in dwellings is increasing rapidly in Sweden. The heat pump extracts heat from the ground by a U-pipe in a vertical borehole. In order to reduce the electricity demand in the system, the combination with solar collectors is introduced. This system may be designed in many ways and the advantages differ a lot. Solar heat can also be used for recharging of boreholes when neighbouring boreholes are thermally influencing each other.

In order to analyze different systems with combinations of solar collectors and ground source heat pumps, computer simulations have been carried out with the simulation program TRNSYS.

Large differences were found between the systems. The optimal design in a new system is to use solar heat is directly for domestic hot water during summertime and (depending on the depth of the borehole) also for recharging of the borehole during wintertime. The advantage is related to the rate of heat extraction from the borehole as well as the whole design of the system. The demand of electricity for the circulation pumps increase with solar recharging, because of the increased operating time. For new, highly efficient circulation pumps this disadvantage decreases and longer operating times for recharging can be accepted.

In existing ground-source heat pump systems the advantage with solar heat in the system depends on the system design. In systems with undersized boreholes the advantage with recharging the borehole with solar heat is large. The optimal system is when solar heat is used directly for domestic hot water during summertime and for recharging of the borehole during wintertime, but for extremely short boreholes, recharging all solar heat is the optimal system.

Solar heat in combination with ground-source heat pumps gives an advantage when the neighbouring boreholes are drilled so close that they are thermally influencing each other. This may lead to decreasing temperatures in the ground, which gives decreased performance of the heat pump and increased use of electricity. The net annual heat extraction from the ground is reduced by recharging with solar heat.

Keywords: solar collectors, ground-source heat pumps, TRNSYS simulations, heating in dwellings, ground heat

Solfångare och bergvärmepump för bostäder – systemanalys

Sammanfattning

Användningen av bergvärmepumpar för uppvärmning av byggnader och tappvarmvatten har i Sverige ökat kraftigt under de senaste 10 åren. Bergvärmepumpar hämtar värme från marken genom U-rör i vertikala borrhål. För att ersätta en del av elanvändningen till värmepumpen har solfångare kommit till användning i systemet. Kombinationen med solfångare kan göras på olika sätt och fördelarna varierar avsevärt.

För att analysera olika system med kombinationer av solfångare och bergvärmepumpar har datorsimuleringar genomförts med simuleringsprogrammet TRNSYS.

Stora skillnader erhöles mellan systemen. Den optimala designen i ett nytt system är att använda solvärme direkt till tappvarmvattensystemet under sommarhalvåret (eller t.ex. mars-oktober) och ev. till återladdning under vintern. Fördelen med solvärme beror speciellt på hur stor del som är tillskottsel i systemet, samt på vilken energimängd per meter borrhål som hämtas ur marken och på hela systemets design. Vid återladdning används el till cirkulationspumpar och denna elanvändning kan överstiga den elbesparing till värmepumpen, som kan erhållas genom återladdning. Med mer energieffektiva cirkulationspumpar än vad som normalt används idag, kan dock längre drifttider och därmed mer återladdning ge elbesparing.

I befintliga bergvärmesystem med underdimensionerade borrhålsdjup är nyttan av återladdning med solvärme stor. För extremt korta borrhålsdjup ger återladdning av solvärme den mesta nyttan. För måttligt underdimensionerade borrhålsdjup är det mest optimala systemet att använda solvärme till tappvarmvatten under vår, sommar och höst, samt att återladda borrhålet under den kallaste tiden.

Vid alltför högt värmeuttag ur brunnen i förhållande till den naturliga återladdningen kan problem uppstå med sjunkande temperaturer i marken. Genom återladdning med solvärme minskar nettouttaget av värme och temperaturen kan återställas. Problemet kan inträffa vid alltför tätt borrade brunnar, men återladdning med solvärme kan därmed också användas för att kunna borra tätare.

Contents

Preface	1
Abstract.....	2
Sammanfattning.....	3
Contents	4
1 Introduction	7
1.1 Background	7
1.2 Objectives	7
1.3 Method	8
1.4 Limitations	9
1.5 Outline	10
1.6 List of papers by the author	12
2 Energy demand and solar irradiation.....	15
2.1 Solar irradiation	15
2.2 Energy demand in buildings	18
3 Solar collectors in combination with ground-source heat pumps.....	23
3.1 Introduction	23
3.2 Previous studies and experiments	28
3.3 The start during the 70s	29
3.4 Projects during the 80s	29
3.5 Activities in the 90s	33
3.6 Recent development from the 2000s to today	36
3.7 Summary of previous studies	41
4 Laboratory study of the heat transfer in water-filled borehole with different ground heat exchangers.....	43
5 Components.....	47
5.1 The heat pump system	47
5.2 Borehole and ground heat exchanger	50
5.2.1 The brine in the ground heat exchanger	53
5.2.2 The bedrock	55
5.2.3 Thermal influence	57
5.3 The solar collectors	59
5.4 The circulation pumps	62
5.5 Combined systems	63
6 Simulations.....	67
6.1 TRNSYS and Simulation Studio	67
6.2 Components used in the simulations	69
6.2.1 The weather model	70
6.2.2 Solar collector model	71
6.2.3 The heat pump	71
6.2.4 The ground heat exchanger	72

6.2.5	The thermal storage	72
6.2.6	The building load	72
6.2.7	The domestic hot water load	73
6.3	The simulation – background aspects	74
6.4	Simulated systems	75
6.4.1	The reference case – system 1	75
6.4.2	All solar heat to the heat pump and the borehole – system 2	77
6.4.3	All solar heat direct to the borehole - system 3	80
6.4.4	All solar heat to the domestic hot water – system 4	81
6.4.5	Solar heat to the ground and to domestic hot water – system 5	82
6.4.6	All solar heat to a brine tank and to the heat pump/borehole – system 6	84
7	Results of simulations	85
7.1	Studied parameters	85
7.1.1	Overview of the systems	85
7.1.2	Overview of the parameters	87
7.1.3	Overview of the figures with the simulation results	89
7.1.4	Minimized use of electricity	91
7.2	Temperature to the evaporator in different systems	92
7.3	COP for the heat pump for a year	95
7.4	Use of electricity	96
7.5	Seasonal Performance Factor (SPF) for the systems	99
7.6	Savings of electricity	100
7.7	Extraction of heat from the borehole	104
7.7.1	Study of the impact of special recharging	108
7.8	Thermal conductivity in the ground	113
7.9	Thermal resistance in ground heat exchangers	118
7.10	Area of the solar collectors	124
7.11	Years of operation	127
7.12	Climate in the south of Sweden	131
7.13	Costs	134
8	Energy balances.....	143
9	Conclusions and discussion.....	147
10	Used symbols and nomenclature	151
11	References	155
11.1	Internet	159
11.2	Software	159

1 Introduction

1.1 Background

There is an urgent need of turning the development in society to a sustainable future. Climate change is ongoing and a sustainable energy system must be built up. Energy is integrated in all activities in society and the building sector accounts for about 40% of the total energy use, both in Sweden and the European Union.

In Sweden, targets have been formulated in order to improve the planning and implementation of a sustainable future. National strategies are pointing at a more efficient use of energy and transport, in order to reduce emissions from the energy and transport sector. The emission of greenhouse gases in Sweden should be 4% lower for the mean value of 2008-2012 compared to the value from 1990. By 2050, the total emissions in Sweden should be lower than 4.5 tones of carbon dioxide equivalents per capita per year. This figure can be compared with the corresponding figure for 2005, which was 7.44 tones of carbon dioxide equivalents per capita (Energimyndigheten 2007).

There is a large potential to decrease the energy demand in buildings and to increase the use of renewable energy, specifically solar energy. New buildings may be constructed extremely energy efficient, but for the existing building stock, energy efficient measures must be implemented gradually.

One opportunity for the owners of single-family dwellings is to install a heat pump, which reduces the amount of bought energy. The transition from oil-boilers to heat pumps results in an increased demand of electricity, compared to replacing electric boilers with heat pumps, which reduce the demand of electricity. Combining solar collectors in a system with heat pumps may reduce the use of electricity, when the solar collectors are replacing the operation of the heat pump. Solar collectors may also be used in more ways in combination with ground-source heat pumps. This study analyses the possibilities and the effects in the systems.

1.2 Objectives

The objective with this study is to identify the conditions and possibilities of using solar heat in combination with ground-source heat pumps in single-family dwellings. The aim was to find systems with the optimal benefit of using solar heat.

One approach has been to analyse the need of electricity in different systems when using solar heat in combination with ground-source heat pumps. The depth of the borehole is important for the performance of the system and solar heat recharging has been studied for systems with different depths of the borehole.

The temperature in the borehole is an indicator of the performance of the ground-source heat pump system and one interesting objective is to analyse this temperature and the influence of solar heat in the systems.

Another objective was to study the advantages with solar heat recharging. The thermal influence of neighbouring boreholes is important and may become a problem in areas where ground-source heat pump systems are situated closely. If the heat extraction cools down the ground, this can be compensated with recharging with solar heat.

Finally, the overall objective was to strengthen the knowledge regarding the conditions for using solar heat in buildings in combination with ground-source heat pump systems and to find the most energy efficient applications.

1.3 Method

The work has been devoted to collecting information about the combination of solar heat and ground-source heat pumps regarding available components, systems, problems and earlier studies.

From the existing knowledge, a reference case was designed and from this reference case different systems were developed. In order to evaluate the performance and be able to make parameter studies, a simulation deck was built up in the simulation program TRNSYS. In the first simulations TRNSYS 15.3 in combination with IISiBat 3.0 was used, but in the final simulations, with the results presented in this report, TRNSYS 16 was used in combination with Simulation Studio 2006. By using this comprehensive tool it was possible to build up a system with a building and a heat load for heating and domestic hot water, the solar collector system and the ground-source heat pump system. The evaluation includes analyses of the performance of the different systems, with the temperature changing in the borehole, the energy flows and especially the demand of electricity.

A laboratory study was performed in order to investigate the thermal performance in a ground heat exchanger and to test the thermal resistance with different pipes, regarding dimension, number and material. By changing the

temperature and the heat injection, observations made in the test results pointed to an increased natural convection in the borehole.

1.4 Limitations

The study is focused on single-family dwellings, which normally has one borehole in a ground-source heat pump system. There is normally no cooling in single-family dwellings in Sweden, so only the heating of the building and domestic hot water has been analysed. In large buildings, multifamily dwellings, non-residential premises or group-system for many buildings, the configuration of many boreholes are critical and other, more specific aspects has to be taken into account. In non-residential premises there is also normally a cooling load which gives other circumstances. The large potential of installations with solar heat combined with a ground-source heat pump system is in single-family dwellings.

Of the ground-source heat pump systems, only these with vertical pipes have been analysed. The reason for this is the interesting possibility to recharge the borehole with solar heat. In the system without recharging, the solar heat replaces the heat pump during summer time, and this is similar to the other ground-source heat pump systems like an open loop ground-water or surface water heat pump system or a closed loop with horizontal piping.

The inputs for the simulations are based on Swedish conditions. The simulated systems are complex and the interpretation of the results should be regarded as a comparison between the systems. The quantified result for each system or simulation may be changed by other input in the systems. To be able to compare the systems, as little input as possible was changed between the simulations.

There are no real measurements to verify the simulations, which would be desirable. The majority of the simulations are done for 20 years of operation, in order to investigate the thermal performance in the ground. The used TRNSYS components are all verified and tested, especially the critical ground heat exchanger in the borehole. The system performance is also dependent of the heat and domestic hot water load in the building, especially the use of domestic hot water in the summer. In the simulations, this can be repeated in all systems and for all years, which gives the possibility to compare the systems.

1.5 Outline

In Chapter 2, the conditions regarding solar irradiation and the energy demand in buildings are presented for Swedish conditions. The northern latitude gives large annual deviations both for irradiation and energy demand. The comparatively low solar angle, due to the northern latitude, enhances the importance of using tilted solar collectors and the optimal tilt coincides with the normal tilt of roofs on buildings.

During summertime there is normally only demand for heating of domestic hot water and small solar collector systems are normally sized to fit this demand. Larger systems can also produce heat for the building during spring and autumn. In Sweden many of the single family dwellings are converting from oil or electric heating to different kind of heat pumps. The interest is large and about 30-40 000 ground-source heat pumps are installed in Sweden every year.

In Chapter 3 the combination of solar collectors and ground-source heat pumps are presented and the different possibilities and advantages of the combination are discussed. The impact of using solar heat in the system is presented for different operation modes.

The background and previous experiences for the combination of solar collectors and ground source heat pumps are presented in the following sections with the start during the 70's. During the 80's several field tests were conducted, also in Sweden. During the 90's the international interest was large regarding testing systems, but almost no plants were tested in Sweden. From the year 2000, the market in Sweden has grown, but the system performance has not earlier been analysed in detail. Although a test facility and simulations were conducted at SERC (Solar Energy Research Centre) in Borlänge, Sweden. The result of the simulations that were carried out, are that the cheapest, unglazed, low-temperature solar collectors have the best economic potential in combination with ground-source heat pumps. On the other hand, a more complex control strategy in systems with glazed solar collectors was not simulated. Field tests have shown that for small systems it might be difficult to follow up operations follow up and the complexity may lead to a decreased efficiency and increased use of electricity.

Chapter 4 summarizes a laboratory test regarding the thermal performance in different ground heat exchangers. Five types of ground heat exchangers were tested in a 3 m long double-walled steel cylinder, where the ground conditions were simulated with different temperatures. The ground heat exchangers were placed in a water-filled plastic pipe and the thermal resistance between the

heat carrier fluid and the borehole wall was determined. The higher the heat transfer is, the more impact the free convection has in the borehole, which improves the heat transfer, as the borehole thermal resistance decreases.

In Chapter 5, the components in a combined solar collector and ground-source heat pump system are described. The different ground-source heat pump systems and the increasing market in Sweden are described. A typical heat pump and the principle system are described as well as sizes and prices.

The borehole and the ground heat exchanger are presented and also the prices. The brine in the ground heat exchanger also has to fit with the solar collectors in systems with combined fluids. The normal temperatures in the bedrock and variations in thermal conductivity are described as well as the thermal influence between adjacent boreholes.

The principle of solar collectors is described in Chapter 5.3. The special features for solar collectors used in combination with ground-source heat pumps are discussed as well as the certification system for solar collectors. The energy efficiency of the circulation pumps is important during the recharging of boreholes and finally an overview of different systems with solar collectors and ground-source heat pump is presented.

In Chapter 6, the simulation program TRNSYS is described and the used models for the different components in the system are presented. In 6.4 the different simulated systems are described in more detail.

The results of the simulations are summarized in Chapter 7 and the different questions to analyse are stated. The minimized use of electricity in the systems is one of the most important questions. Another interesting task is to analyze the temperature in the brine from the borehole to the evaporator. The coefficient of performance for the heat pump (COP), the use of electricity as well as the seasonal performance factor (SPF) for the systems are important questions for the evaluation of the systems. The extracted heat from the borehole is important in areas with many boreholes. To be able to see the effects of recharging, a few tests are presented, where a defined power is injected and the systems performance is analysed. Also the system behaviour with varied thermal conductivity in the ground, thermal resistance in the ground heat exchangers, the area of the solar collectors, the number of years of operation and the climate were simulated. The Chapter ends with calculations of the costs.

The yearly energy balances in the reference systems are presented with Sankey-diagrams in Chapter 8. These diagrams give a visual presentation of the size of the energy flows in the different systems.

Finally, the conclusions and discussion are presented in Chapter 9. The used terms and symbols are listed in Chapter 10.

1.6 List of papers by the author

Parts of the content in this thesis have been presented and published in the following publications. The work input by the author is listed within each paper. The original papers are not included in the thesis. The content is used as a base in this updated, more coherent thesis.

Paper 1

Hellström G, Kjellsson E. (2000). Laboratory measurements of heat transfer properties of different types of borehole heat exchangers. Proceedings of Terrastock 2000, International Conference on Thermal Energy Storage, Stuttgart, Germany.

The paper presents laboratory measurements on different types of borehole heat exchangers in order to study the thermal resistance in the borehole. This study is described in Chapter 4 in this thesis. Work input: Responsible for the laboratory experiments. Evaluation and writing with supervision.

Paper 2

Kjellsson E, Hellström G, Tepe R, Rönnelid M, (2003). Combination of Solar Heat and Ground Source Heat Pump for Small Buildings. Proceedings from Futurestock 2003, Warsaw, Poland.

This paper presents the background and possibilities of using combinations of solar collectors and ground source heat pumps for heating buildings. The content is included in Chapter 3 in this thesis. Work input: Main author of the background material.

Paper 3

Kjellsson E, Hellström G, Perers B, (2005). Solar Collectors and Ground-Source Heat pump in Combination. Proceedings from NorthSun, Conference on Solar Energy on High Latitudes 2005, Vilnius, Lithuania.

This paper presents the first TRNSYS simulations of combinations of solar collectors and ground source heat pumps for heating buildings. Work input: Main author, development of modelled systems, simulations and analysis. The content is also included in the licentiate thesis:

Kjellsson E. 2004. *Solvärme i bostäder med analys av kombinationen solfångare och bergvärmepump* (in Swedish, Solar Heating in Dwellings with Analysis of Combined Solar Collectors and Ground-Coupled Heat Pump). Licentiate thesis, Building Physics, Lund University, Sweden, Report TVBH-3047, Lund.

Paper 4

Kjellsson E, Hellström G, Perers B, (2005). Combination of Solar Collectors and Ground-Source Heat pump for Small Buildings. Proceedings from ISES Solar World Congress 2005, Orlando, USA.

This paper presents the first TRNSYS simulations of combinations of solar collectors and ground source heat pumps for heating buildings. Work input: Main author, development of modelled system, simulations and analysis. The content is also included in the licentiate thesis, as above.

Paper 5

Kjellsson E, Hellström G, Perers B, (2008). Optimization of Systems with the Combination of Ground-Source Heat Pump and Solar Collectors in Dwellings. Proceedings from SET2008, International Conference on Sustainable Energy Technologies, Seoul. Korea.

This paper presents parts of the results from the TRNSYS simulations also presented in this thesis. Work input: Main author, development of modelled systems, simulations and analysis.

Paper 6

Kjellsson E, Hellström G, Perers B, (2009). Analyses of Ground-Source Heat Pumps Combined with Solar Collectors in Dwellings. Proceedings from Effstock 2009 Thermal Energy Storage for Efficiency and Sustainability, International Conference 2009, Stockholm, Sweden.

This paper presents parts of the results from the TRNSYS simulations also presented in this thesis. Work input: Main author, development of modelled systems, simulations and analysis.

Paper 7

Kjellsson E, Hellström G, Perers B, (2009). Optimization of Systems with the Combination of Ground-Source Heat Pump and Solar Collectors in Dwellings. Submitted to Energy (2009), Elsevier, Journal, status: in press, available at: sciencedirect.com

This paper presents parts of the results from the TRNSYS simulations also presented in this thesis. Work input: Main author, development of modelled systems, simulations and analysis.

2 Energy demand and solar irradiation

This Chapter describes the solar irradiation and the heating demand in single-family dwellings in Sweden.

2.1 Solar irradiation

The radiation from the sun falling on the earth outside the atmosphere is 1367 W/m^2 (Duffie & Beckman 1991). The annual global solar irradiation on the earth depends on the latitude, as the angle of incidence of the solar irradiance results in a lower radiation at higher latitudes. There are two reasons for this. One is that the distance through which the solar radiation has to travel in the atmosphere is longer at higher latitudes, resulting in increased absorption and reflection before reaching the earth. The other reason is that the higher angle of incidence results in a lower irradiance on the horizontal ground. However, this may be compensated by a tilted surface towards the sun. Normally the horizontal irradiation is presented and the northern latitudes, as for Sweden, get unfavourably low figures, see Figure 2.1

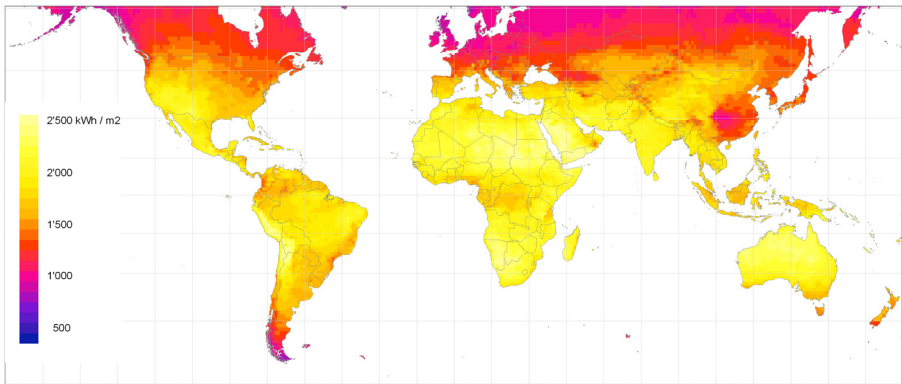

Figure 2.1 The annual global irradiation in the world on a horizontal surface (kWh/m^2) (Meteotest database Meteonorm).

When using solar energy integrated in buildings, the optimal conditions for the irradiation on the solar collectors is not always possible to achieve, as the design of the building depends on a large variety of factors. In single family dwellings the most common roof tilts are normally suitable as supporting structures for solar collectors.

The total global irradiation on all tilts and azimuth for the southern part in Sweden is shown in Figure 2.2. The optimum azimuth is about +/- 30° from the south and the optimum tilt is between 20-55° from horizontal.

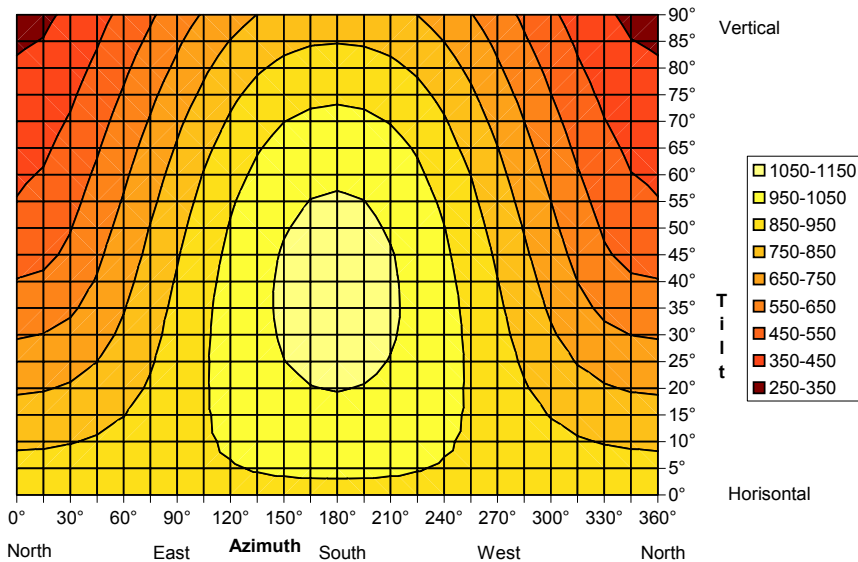

Figure 2.2 Global irradiation depending on different tilts and azimuth for the southern part of Sweden (Climate data for Jönköping average 1962-90) in kWh/m²,year (Kjellsson 2000).

The maximum annual global mean irradiation is around 1100 kWh/m² in the south of Sweden and about 900 kWh/m² in the north. The relative irradiation is shown in Table 2.1

Table 2.1 The relative irradiation towards surfaces with different tilts and azimuth for Jönköping weather data (average 1962-1990) (1.00 = maximal irradiation) (180°=south) (Kjellsson 2000).

Azimuth	Flat roof 0°	0° - 20°	20° - 35°	35° - 50°	50° - 85°	Wall 90°
0° - 15°	0.85	0.77	0.62	0.50	0.38	0.29
15° - 45°	0.85	0.78	0.65	0.55	0.44	0.34
45° - 75°	0.85	0.80	0.72	0.65	0.55	0.44
75° - 105°	0.85	0.84	0.81	0.78	0.68	0.55
105° - 135°	0.85	0.87	0.90	0.89	0.79	0.65
135° - 165°	0.85	0.90	0.96	0.96	0.87	0.71
165° - 195°	0.85	0.91	0.98	0.99	0.89	0.73
195° - 225°	0.85	0.90	0.96	0.96	0.87	0.71
225° - 255°	0.85	0.87	0.90	0.89	0.79	0.65
255° - 285°	0.85	0.84	0.81	0.78	0.68	0.55
285° - 315°	0.85	0.80	0.72	0.65	0.55	0.44
315° - 345°	0.85	0.78	0.65	0.55	0.44	0.34
345° - 360°	0.85	0.77	0.62	0.50	0.38	0.29

The annual variation in solar irradiation is large in high latitudes. In Figure 2.3 the horizontal irradiation for the southern part of Sweden is shown for the global, diffuse and theoretically clear day for weather data between 1962-1990. In Sweden the diffuse part of the global irradiation is just above 50%, which is relatively high. During the operation time for a conventional solar collector system, the diffuse part of the irradiation is about 25%. In Figure 2.3 the variation between the daily highest (with blue sky) and lowest (with only diffuse) is large and the annual variation may be $\pm 15\%$ from the mean value (Kjellsson 2004).

Meteo for Jönköping, Reference Year

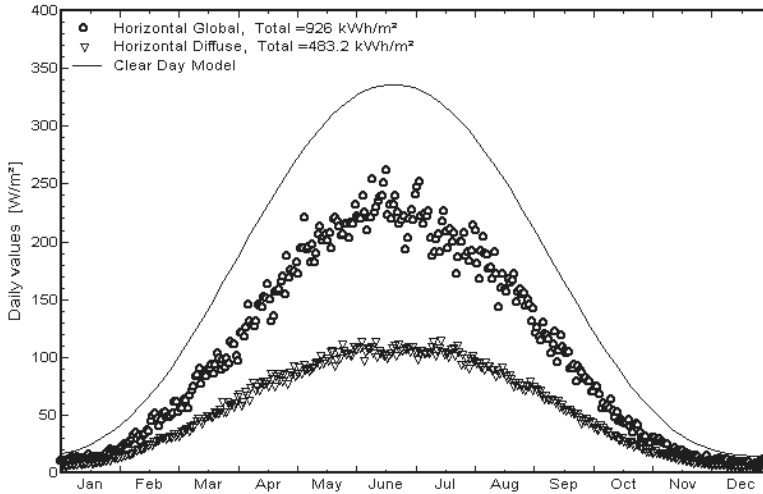

Figure 2.3 Distribution over the year of the horizontal global, horizontal diffuse and a theoretically clear day irradiation for Jönköping, as average for the southern part of Sweden ($W/m^2, day$). Weather data for Jönköping average 1962-1990 (Kjellsson 2000, PVSYST software).

2.2 Energy demand in buildings

The need of supplied energy to the buildings is determined by the demand of comfort in the building, e.g. temperature, humidity, air velocity and quality of the indoor air. The technical standard of the building, such as insulation and air-tightness, gives the dependence of the outdoor temperature. The seasonal variation of the energy demand in the building stock in Sweden is large, but will be decreased with a more energy efficient building stock, as the new constructions are improved and the existing will gradually be refurbished.

In Figure 2.4 the annual distribution of the heating demand including domestic hot water is shown for two levels of heat demand in single family dwellings in Sweden. The large heating demand represents a conventional building, with the total annual load of about 23 000 kWh, which is close to the average for all single-family dwellings in Sweden and the small represents a new, highly energy efficient building (Energimyndigheten and SCB 2007a). The annual variation is high in the conventional building, compared to the energy efficient dwelling. The normal sizing of a small solar collector system is that the production of solar heat covers the heating demand during summertime. In larger systems, the solar heat can be used also in the heating system during

spring and fall, but during summer the demand is smaller than the possible production. In very highly energy efficient buildings, the solar heat can deliver a large part of the heating demand, as shown in Figure 2.4.

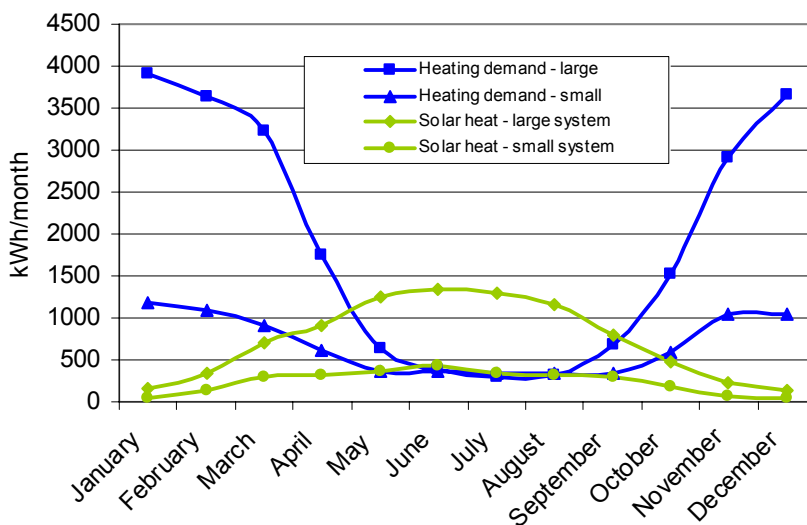

Figure 2.4 Example of the annual distribution of large and small heating demand (incl. domestic hot water) in single family dwellings and possible solar heat production in large and small systems respectively.

In Sweden, about 1 780 000 single-family dwellings are permanently inhabited. The number of dwellings heated with oil and combinations with oil (oil/electricity or oil/biomass) in Sweden is decreasing and the oil is replaced with biomass (mainly in combination with electricity) and heat pumps. In 2006, biomass and the combination of electricity and biomass were used in 33% of the single family dwellings. This is the same figure as for the use of only electricity for heating. Grounds-source heat pumps were used in 11% of the buildings and district heating in 9% (Energimyndigheten and SCB 2007b).

According to a survey from SCB, the percent of the heated area in single-family dwellings, totally or partly heated by heat pumps, was 17% in 2003 and 32% in 2006 (Energimyndigheten and SCB 2007b).

This means that the use of oil for heating buildings is decreasing rapidly and the consumption was in the year 2006, only half compared to 2004, see Table 2.2 (Energimyndigheten and SCB 2007b). Except for a small increase for single-family dwellings connected to district heating network, the total energy

use has decreased. This may be explained by increased energy efficiency in the buildings but also the transition from oil and electric heating to heat pumps. For the buildings using heat pumps, only the electricity is counted and the much larger part from the heat source is not included in the statistics at all.

Table 2.2 Estimated total use of energy for heating and domestic hot water in single family dwellings in Sweden, for the years 2001-2006 (TWh/year) (Energimyndigheten and SCB 2007b).

Heating system / fuel	2001	2002	2003	2004	2005	2006
Oil	9.9	9.0	8.1	7.8	5.4	3.4
District heating	2.8	3.0	3.6	3.7	3.7	4.7
Electricity*	16.2	16.5	15.8	16.3	15.3	15.3
Biomass	9.4	9.9	10.7	10.0	11.2	8.8
Gas	0.2	0.3	0.2	0.2	0.4	0.3
Total	38.4	38.6	38.4	37.9	36.0	32.4

*excl. household electricity

The average use of energy for heating and domestic hot water per heated area varies a lot between the different fuels or types of energy. The average in single family dwellings was 23 400 kWh in 2006. In buildings with ground-source heat pumps the use of electricity was 17 000 kWh and for buildings with oil or biomass the figure was around 30 000 kWh (Energimyndigheten and SCB 2007a).

In 2006 the total number of heat pumps in Sweden was 544 000. This number has increased by 15% during 2005 (Energimyndigheten and SCB 2007b). About half of the total number was ground-source or lake heat pumps, and the rest were air/air or air/water/exhaust air heat pumps, see Table 2.3.

Table 2.3 The total number of heat pumps in dwellings and non-residential premises in Sweden 2006 in (Energimyndigheten and SCB 2007b).

	Ground-source/lake heat pumps	Air/water /exhaust air heat pumps	Air/air heat pumps	Total
Single family dwellings ¹	215 000	102 000	198 000	509 000
Multi-family dwellings	10 000	9 000	2 000	21 000
Non-residential premises	6 000	3 000	5 000	14 000
Total	231 000	114 000	205 000	544 000

¹ 6000 single family dwellings have two types of heat pumps, which are added to both ground-source/lake heat pumps and air/air heat pumps

The official statistics might be too low, as there has been an extra real estate tax for heat pump installations, and when considering the numbers of drilled boreholes for energy use, the estimated figure of the total number is 350 000 – 400 000 ground-source heat pump installations for single-family dwellings.

3 Solar collectors in combination with ground-source heat pumps

This Chapter describes the system with the combination of solar collectors and ground-source heat pump in dwellings and possible variations for using solar heat in the system. It also summarizes previous studies, experiments and activities from the 70s and after, mainly in Europe and especially in Sweden.

3.1 Introduction

Combining solar collectors with ground-source heat pumps in dwellings provides opportunities for different system solutions that can be adapted to different conditions and applications. Figure 3.1 shows a schematic drawing of a system with solar collectors and ground-source heat pump.

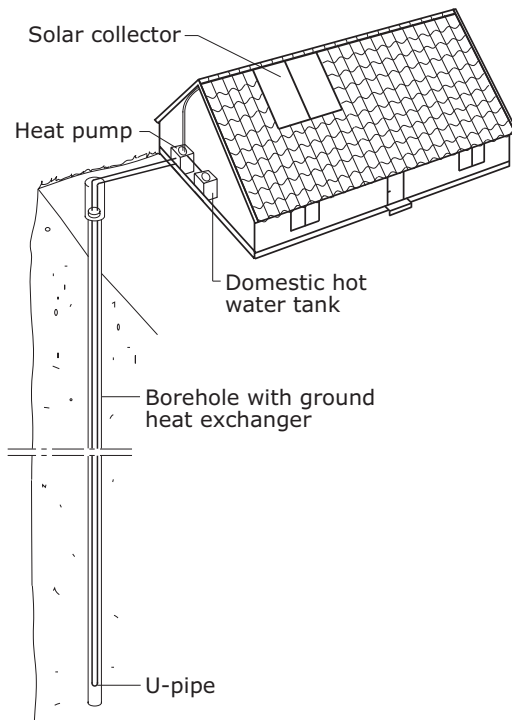

Figure 3.1 Single-family dwelling with solar collector and ground-source heat pump.

Both the solar collectors and the heat pump can get new operational conditions that provide better efficiency, when used in the same system. The solar collectors can produce useful energy at lower temperatures, as compared with conventional use of solar heat in dwellings, leading to better efficiency because of decreased heat losses, and increased time of operation, as the lower levels of irradiation may be utilized and the borehole can be recharged. The efficiency of the heat pump can be increased as the brine temperature to the evaporator is increased by the solar collectors. The system efficiency may be increased as the solar collectors during summertime replace the operation of the heat pump. Figure 3.2 shows an example of the system with solar collectors in combination with heat pump and borehole with ground heat exchanger.

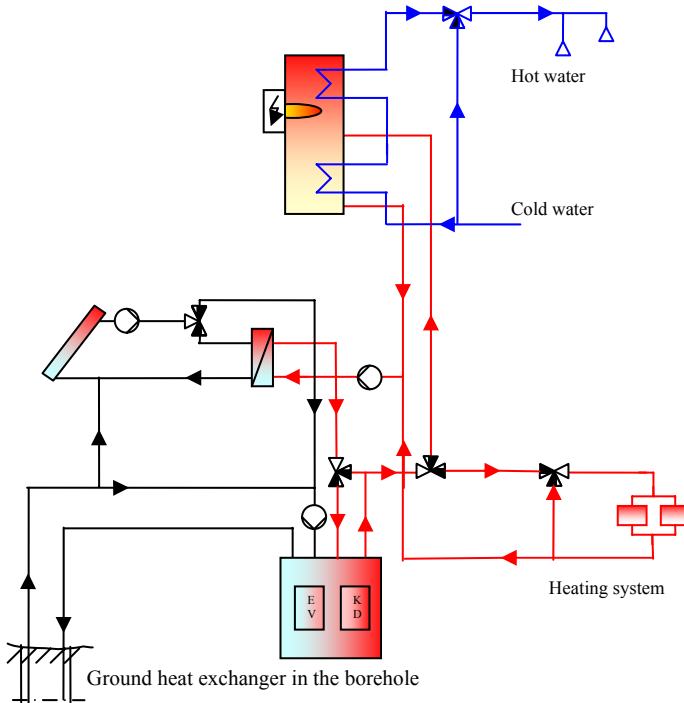
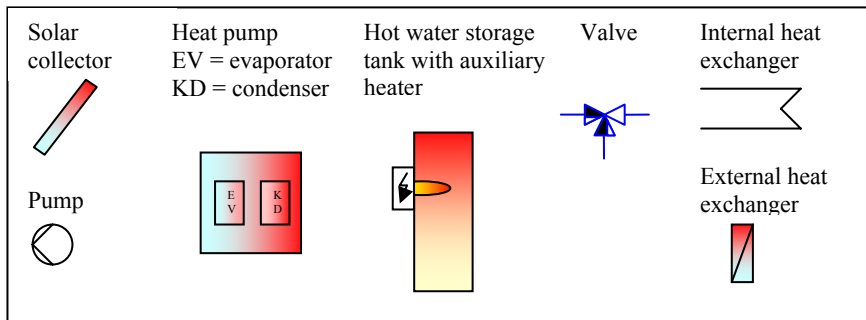

Figure 3.2 Example of a system with solar collectors in combination with ground-source heat pump. See legend below.



The benefits of a combination of solar collectors and ground-source heat pump are several and varied, depending on the type of solar collectors, the system and how the regulation of the system is designed. One advantage is that the solar collectors can produce all heat for the domestic hot water during the summer, when the heat pump otherwise works during many but short periods of operation. This wears the heat pump more than the relatively smooth operation during the rest of the year. The life span of the heat pump may be increased and the boreholes recharges naturally from the environment, as the heat extraction from the borehole is low for about 3 months.

With an efficient control strategy for the solar collector system, the solar heat can be used in other ways during the times when the solar collectors can not producing sufficiently high temperatures to be utilized for hot water or if there is no need to heat the domestic hot water. The solar heat may then be used for the heating system in the building, or if the temperature from the solar collectors is too low even for this, the solar heat may be used to raise the temperature of the brine to the evaporator, giving the heat pump better operational conditions. If there is no heating demand in the building, or if the temperature of the solar collectors is too low, the solar heat may be used to recharge the borehole, se Table 3.1.

Table 3.1 Different possibilities of using solar heat in combination with ground-source heat pump and effects on the system.

Mode of operation	Solar collector	Heat pump	Borehole
1. Solar collector is used to produce or preheat domestic hot water	Heat production at “high” temperatures (>50°C), or lower for preheating	Heat pump not in operation	No heat extraction
2. Solar collector is used to produce heat for the heating system	Heat production at lower temperatures (about 20-50°C) gives increased efficiency and longer operation time	Heat pump not in operation	No heat extraction
3. Solar collector is used to increase the temperature in the brine to the evaporator in the heat pump	Heat production at lower temperatures (about 5-20°C) gives increased efficiency and longer operating time	Heat pump in operation, increased COP because of high temperature to the evaporator, which increases the heat production and decreases the operation time	Reduced heat extraction
4. Solar collector is used to produce heat for recharging of the borehole	Heat production at lower temperatures, gives increased efficiency and longer operating time	Heat pump is not in operation – no other heating demand The operational conditions for the heat pump is improved for the season	Heat injection to the borehole gives increased temperature

The advantages of recharging of the borehole may be:

- increased fluid temperature which gives
 - possibility of using shorter boreholes or
 - possibility for a higher rate of extraction of heat from the borehole

- reduction of the thermal influence of neighbouring boreholes with reduced net heat extraction
- solar collectors and boreholes may be designed for seasonal heat storage in a system with a group of houses with a common heat distribution network

The reduction of the thermal influence is of special interest in densely populated dwelling areas, where a concern for long-term thermal influence between adjacent boreholes might lead to restrictions on the use of ground heat sources.

The recharging with solar heat may also be used to:

- increase the temperature to the evaporator when the active borehole depth is undersized e.g. because of
 - higher heating demand than designed
 - the ground thermal conductivity was lower than predicted
 - the ground water level was lower than predicted
- counteract freezing of boreholes
- counteract influence of adjacent boreholes

Furthermore, the problem of the right to the direct ground-heat may occur in densely populated areas with influencing boreholes drilled too close to each other. In these cases, recharging may be one solution. Finally, a large system with many configured boreholes, including a large volume in the ground, can be used for seasonal storage of solar heat.

The interest in the combination of solar heat and ground-source heat pumps started in the late 70's, when the use of solar energy was increasing, but it is only in recent years it has become a commercially viable solution. The conditions for the components have changed over the years, both technical and economical. Specially the advanced possibilities in a new control system have changed since the 70's, but also the costs of solar collector system and ground-

source heat pump system respectively, and not at least the cost of the conventional heating.

The interest in ground-source heat pumps has risen sharply in recent years and the number of installations for vertical and horizontal ground-source and lake heat pump systems has increased from about 12 000 per year in the late 90's to 30 000 - 40 000 in the recent years.

In the statistics from The Swedish Heat Pump Association (SVEP), the increase in sold ground-source heat pumps is large since the year 2000, see Figure 3.3.

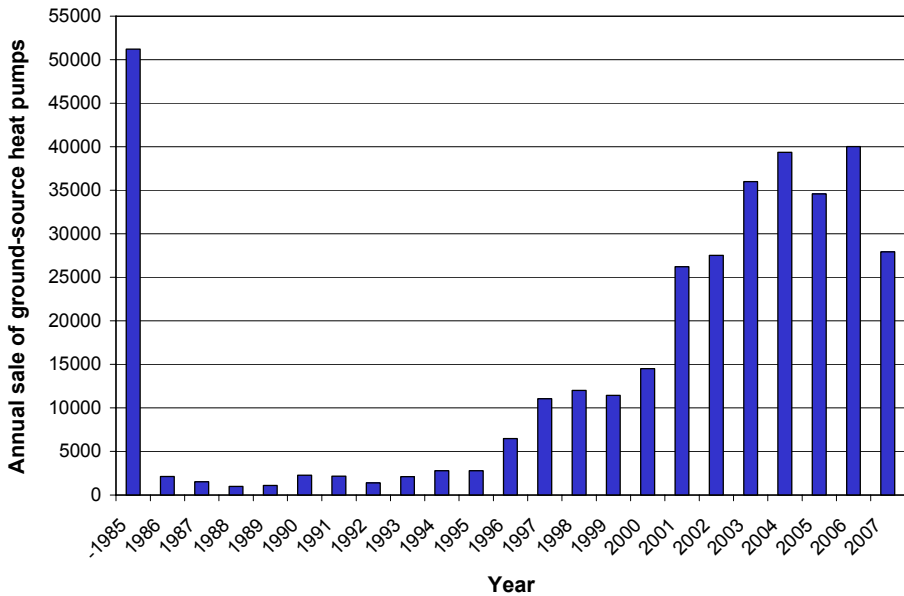

Figure 3.3 The annual sale of ground-source heat pumps in Sweden between 1986-2007 and the total before 1986. Statistics from Svenska Värmepumpföreningen (SVEP 2008).

3.2 Previous studies and experiments

A number of test projects with a combination of solar collectors and ground-source heat pumps, were carried out in Europe over the 80's and the 90's. The results indicate, in general, that the systems are so complex and diverse, that it

is difficult to draw any general conclusions about the usefulness and design for other conditions, such as climate, local conditions and energy performance.

3.3 The start during the 70s

As early as 1979, a Nordic symposium, *On Earth Heat Pump Systems*, was held in Gothenburg (Bäckström 1979). Although the focus of the symposium was on ground heat in combination with heat pumps, a case study from New York, where solar collectors were used to increase the temperature to a ground-source heat pump, was reported. Another project from Oklahoma in the US reported solar recharging of boreholes with ground heat exchanger including measurement results from 1978/79. The report shows a positive result with solar recharging, but no financial report is included.

3.4 Projects during the 80s

During the 70s the IEA (International Energy Agency) started the first international research work and the work was organised into different programmes:

- Solar Heating and Cooling Programme
- Energy Storage Programme
- Advanced Heat Pump Programme

The Solar Heating and Cooling Programme and the Advanced Heat Pump Programme organised, together with the CEC Joint Research Centre in Ispra, Italy, three workshops with the title: *Solar Assisted Heat Pumps Coupled with Ground Storage*, in Ispra 1982, in Vienna 1985 and in Gothenburg in 1989.

During the first workshop in Ispra 1982, a variety of system solutions for various projects were presented. The results of many of these projects were presented later in the second conference. The variety between the projects was large and general conclusions were difficult to draw. Total 26 projects were reported.

For the combination of solar collectors, heat pump and boreholes, 7 realised and 1 planned projects were presented in the second workshop in Vienna (Hattem 1985). As the title of the workshop indicates "*Solar Assisted Heat Pumps Coupled with Ground Storage*", the ground part in the system was more regarded as an opportunity for storing heat, rather than as a heat source

for the heat pump. The four projects carried out with single family houses, were simple unglazed solar collectors or air convectors. Flat plate solar collectors were mainly used in combination with water storages or tanks in the ground, except for two Swiss projects that combined flat plate solar collectors with horizontal pipes. There were no reported projects with the combination of flat plate solar collectors, heat pumps and boreholes. The result from the projects with vertical tubes is that they were relatively small to be effective as heat storage and that the recharging in these small systems is not yielding sufficient efficiency. It was concluded that this type of recharge was not viable for small systems.

The focus of the third workshop was on the design and economics (Dalenbäck 1990). The group of organizers was now also including the IEA Energy Storage Programme. The majority of the presentations were projects with seasonal storage, but in one project from Germany (Schaeffstall), the combination of domestic hot water demand and solar heat from unglazed solar collectors was reported. The storage consisted of 100 ground heat exchangers in 10 m deep boreholes. This project presented a promising economy with 13 year payback time and also presented the cheaper solutions for drilling, which would bring down the payback time to 9 years (Reuss et al 1990). Another project in Italy (Treviglio) reported design parameters and compared the measured results for three different system solutions. Two systems included 220 respectively 197 boreholes (11 m deep) and the third system was connected with horizontal pipes. The unglazed rubber solar collector (Pirelli), was connected to the evaporator or directly to the ground heat storage. The estimated COP was 4.2 and the measured was 4.0 respectively 3.6 for the two plants with vertical pipes (Mazzarella 1990).

In Sweden, Vattenfall performed extensive tests on solar heat in combination with small ground-source heat pump systems (Spante et al 1986), see example in Figure 3.4.

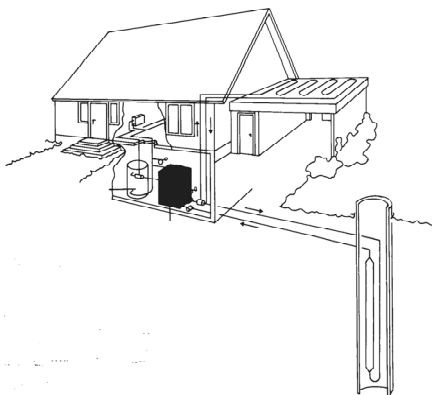

Figure 3.4 System with solar absorbers and ground heat exchanger, tested by Vattenfall during the 80's (Spante et al 1986).

Experiences from 19 plants with heat pumps in operation during 1984/85 were reported. In 14 of the plants, recharge of the borehole with simple unglazed solar collectors or air convectors were used, see Table 3.2. The systems performed well regarding energy performance, operating time and COP, but the conclusion was that it was more cost effective to drill deeper holes than trying to recharge, as the temperature rise was only about 2°C with this type of system.

Table 3.2 shows that the SPF for the heat pumps, ranged between 2.0 and 2.4, which is relatively low. The recharging was performed with simple solar collectors or air-convectors and the recharged energy consisted of a contribution from the direct solar energy and partly by a convective part from the outdoor air. The collected energy from the recharging equipments has only been used to heat the boreholes and the effect of this was so low that it was not possible to distinguish any difference between the systems with or without recharging respectively, regarding SPF or energy system fraction. The temperature in the boreholes increased although by about 2°C with recharging.

The extra cost in 1986 for the simple the solar collectors was about 7 000 SEK incl. VAT (about 13 000 SEK in 2007) and the cost of a heat pump (8 kW at 0/45°C) and a borehole with a depth 105 m was 80 000 SEK incl. VAT (approximately 145 000 SEK in 2007). The total cost to drill the hole was about 30% of the total investment and the additional cost to drill deeper was 230 SEK/m (420 SEK/m in 2007). As the advantage with the recharging was in the same order as to drill a 10 m deeper borehole, the result of the study was that it is more cost effective to drill deeper.

Table 3.2. Overview of 6 systems with ground-source heat pumps and solar heat recharging during 1984/85 (Spante et al 1986).

Place	Älvsjö	Sundby- berg	Lotorp	Älvsjö	Frösön	Öster- sund
Depth of borehole	110 m	110 m	142 m	85 m	135 m	127 m
Recharging equipment, see below, area	TRP (1) 18 m ²	TRP (1) 17 m ²	Solplåt (2) 9 m ²	Luftkv (3) 50m ²	Solplåt (2) 5 m ²	Luftkv (3) VENT TEKN
Heat pump manufacturer	Ahsell DST-5	Thorvent VV801-5	DEBE GM50	Thermia MODUL12	VENT TEKN VTVP010	VENT TEKN VTVP010
Cooling power (4)	7.5 kW	6.5 kW	7 kW	7.5 kW	6 kW	6 kW
Heating power	12 kW	10 kW	10 kW	12 kW	10 kW	10 kW
System fraction of load	77%	95%	78%	81%	87%	85%
SPF seasonal performance factor	2.4	2.0	2.1	2.3	2.4	2.2
Heating load (kWh/year)	38600	33800	59500	44400	42100	36100
Operating time Heat pump (h)	2654	4782	4420	3959	3956	3272
Heat production Heat pump (kWh)	29600	32000	46400	3600	36600	30800
Operating time recharging (h)	3503	4345	2973	4568	2652	4745
Heat extraction from borehole (kWh)	17300	16200	24500	20300	21600	16800
Energy used for recharging pumps (kWh) (5)	9500	5500	4200	4600	2200	4700
Heat power from borehole extraction (W/m) (6)		13	17	23	17	16

(1) TRP = Troughed, blackpainted sheets of aluminium (Area=external dimension)

(2) Solplåt = Blackpainted, flat sheets of aluminium (Area=external dimension)

(3) Luftkv = Absorbers with aluminium fins and copper pipes (Area= fin-area)

(4) Nominal cooling power at 0°C brine inlet temperature to the evaporator and 45°C condenser temperature

(5) Estimated or uncertain values of recharging with energy

(6) Yearly average heat power rate of extraction per meter effective borehole, corrected for recharged energy

3.5 Activities in the 90s

At the end of the 90s, there were more than 100 000 ground-source heat pump systems in Europe, with about half of them in Sweden and the rest mainly in Germany, Austria and Switzerland (OPET Seminar 1999). Despite the fact that there were many systems with ground-source heat pumps in Sweden, the systems, presented in international conferences and seminars, with solar collector combinations, were from the other three countries. Unfortunately, the reported projects are mostly examples of plants that were under construction or just put into operation and only a few projects have evaluated the performance with measurements.

Two projects from Austria with a combination of solar collectors and ground-source heat pump presented measured figures and energy balances. The project in Klagenfurt, consists of a single-family dwelling with 218 m² living space, 20 m² solar collectors and 1 m³ heat storage, linked to a ground-source heat pump. For 1994, the heat load in the building, including domestic hot water, was about 17 100 kWh. The solar collector system produced about 5 000 kWh. About 8 400 kWh were retrieved from the ground with the heat pump and about 3 700 kWh (22%) of electricity was used by the heat pump (Faninger 1999).

Another project in Linz was reported briefly for the year 1996. It is a multi-family dwelling with 9 apartments in Ökopark Linz, with about 490 m² of living space, linked to ground-source heat pumps and solar collectors. In this

project, the demand of electricity accounted for only 9% of the load for heating and domestic hot water, the rest was delivered from the solar collectors and the ground heat from the heat pump (Faninger 1999).

There are some projects that have been reported from Germany, which are not evaluated but can be seen as examples of applications. "Blumberger Mühle" is a visitors' centre in a nature reserve "Schorfheide" (Sanner and Lehmann 1997). In order to provide the information-centre an ecological profile, the building was equipped with several low-energy applications including an energy-efficient building, low-temperature-system, solar collectors, heat pump and ground-source heat storage. The solar collector system was designed to cover 75% of the domestic hot water load (totally of 21 000 kWh/year) and the heat pump together with the solar collectors, 91% of the total heat load (55 000 kWh/year). The remaining part of the heating demand was covered with a gas boiler. The system included 110 m² flat plate solar collectors and the ground-source heat pump system had 15 U-tubes with 32 m depth and finally a 32 kW heat pump.

Another example of ground-source heat pump with solar collectors is a project in Germany completed in 1997. It is situated in Stuttgart-Rohr and includes 28 U-tubes to a depth of 100 m, and a 175 kW heat pump, combined with 161 m² of flat plate solar collectors. The system is shown in Figure 3.5.

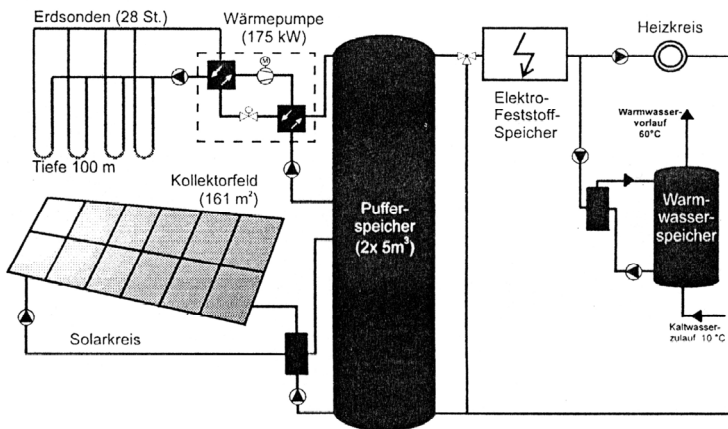

Figure 3.5 System with solar collectors and ground-source heat pump in the project in Stuttgart-Rohr (Sanner and Lehmann 1997).

In this system the heat pump delivers 75% and the solar collector system 15% of the total yearly heating demand of 550 MWh. The SPF for the heat pump is estimated to 3.8 (Sanner and Lehmann 1997).

A project was reported from Karlsruhe in Germany. The systems included a 40 kW heat pump linked with 3 vertical ground heat exchangers (50 meters deep), and 40 m² unglazed solar collectors, see Figure 3.6. The heat pump can either use the heat from the ground heat exchangers or from the unglazed solar collectors, depending on which temperature is the highest. The system also included 15 m² flat plate solar collectors connected to a buffer heat storage. The solar heat from these solar collectors is mainly used for heating the domestic hot water (Pfeil et al 1996).

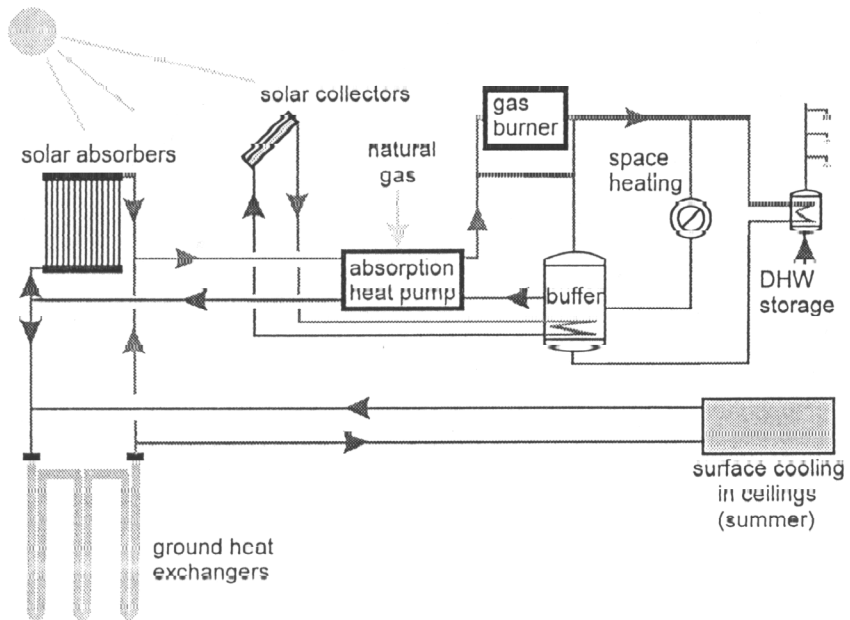

Figure 3.6 The system in Karlsruhe, with both flat plate solar collectors for domestic hot water and unglazed solar collectors connected to the heat pump (Pfeil et al 1996).

In Switzerland, a research project in 1998 identified the benefits of combining ground-source heat pump and solar collectors in a system where the solar collectors are linked to the domestic hot water system (Hässig et al 1998). By using the solar collectors during the summer time, there is no heat extraction from the ground during summer and a maximal, natural recharging from the surrounding ground is possible. The cost-effectiveness depends on several

factors like design of the boreholes, rate of heat extraction, thermal conductivity of rock, solar heat production etc. The results from Switzerland highlighted the complexity of optimization and that further studies are needed.

3.6 Recent development from the 2000s to today

SERC (Solar Energy Research Center) at the University of Dalarna in Borlänge, Sweden, investigated the energy performance of the combination of solar collectors and ground-source heat pumps. During 2001-2002, a study of the Swedish combinations of systems with solar collectors and ground-source heat pumps on the market was performed. Preliminary computer simulations of the selected combinations were conducted.

At SERC there was also a test facility with 28 m² unglazed solar collectors combined with a heat pump and a 145 m deep borehole. The test facility has been used to develop the low-temperature solar collector EMA (Elastomer-Metall-Absorber), which is designed as a tin plated roof with a built-in "rubber"-pipe (Tepe and Rönnelid 2002).

In the market overview of the Swedish system designs, five manufacturers were found with three system solutions. In these systems the solar heat either was used just to charge the borehole or to heat the domestic hot water with the possibility to charge the borehole in case of surplus solar heat. In one of the systems there were also options of using solar for heating the building and to increase the temperature to the evaporator (Tepe and Rönnelid 2002).

The results of simulations with the computer program TRNSYS was presented in 2003 by Tepe, Rönnelid and Perers. The results showed an increase in the SPF and a reduction of the demand of electricity by using solar heat in a system with a 4 kW_{el} heat pump and with 100 m depth of the borehole. Simulations were carried out for three different heating demands of a dwelling (7.0 MWh/year, 12.6 MWh/year and 19.5 MWh/year), 3 MWh/year domestic hot water for all three loads and two types of heating systems (low temperature, max 40°C respectively high temperature, max 60°C). Four different systems were simulated:

1. Reference system without solar collectors
2. 6 m² glazed solar collectors used only for domestic hot water
3. 50 m² unglazed solar collectors linked to the heat pump evaporator at times when the heat pump is in operation, or else to the borehole

4. A combination of systems 2 + 3, both the glass and unglazed solar collectors as described above.

The results of the simulations are shown in Tables 3.3 and 3.4.

Table 3.3 SPF for the three systems with solar collectors and ground-source heat pump, and the reference without solar collectors. The results of the simulations for the third year in operation, for two different heating loads and two different design flow temperatures in the heat distribution system (Tepe, Rönnelid and Perers 2003).

Seasonal performance factor (SPF)	Design flow temperature of heat distribution system 40°C		Design flow temperature of heat distribution system 60°C	
	Heating demand 10 MWh/year	Heating demand 22,5 MWh/year	Heating demand 10 MWh/year	Heating demand 22,5 MWh/year
1. Reference	3,3	2,6	2,7	2,3
2. Glazed solar collectors	4,2	2,9	3,3	2,5
3. Unglazed solar collectors	3,6	2,9	2,9	2,6
4. Combination of glazed and unglazed solar collectors	4,5	3,2	3,4	2,7

For systems with solar collectors, the SPF ranged from 2.5 to 4.5. Both the heating demand and the level of temperature in the heating system have a relatively high importance for the SPF, which increases with a decreased heating demand or decreased temperature level in the heating system (Tepe, Rönnelid and Perers 2003).

Table 3.4 Reduced demand of electricity for the three systems with solar collectors and ground-source heat pump compared to the reference system without solar collectors. The results of the simulations for the third year in operation, for two different heating loads and two different design flow temperatures in the heat distribution system (Tepe, Rönnelid och Perers 2003).

	Design flow temperature of heat distribution system 40°C		Design flow temperature of heat distribution system 60°C	
	Heating demand 10 MWh/year	Heating demand 22,5 MWh/year	Heating demand 10 MWh/year	Heating demand 22,5 MWh/year
1. Reduced demand of electricity (kWh/year)				
2. Glazed solar collectors	550	725	550	700
3. Unglazed solar collectors	275	1000	300	1025
4. Combination of glazed and unglazed solar collectors	700	1550	725	1550

The heating demand is important for the reduced demand of electricity, while the design temperature in the heat distribution system did not affect the reduced demand of electricity significantly (Tepe, Rönnelid and Perers 2003).

The variations of the temperatures in the borehole were described. The reference system showed temperatures around 4°C (with about 1°C variation over the year). Case 3 (as above) with unglazed solar collectors, showed significant seasonal variations, from 5-6°C (winter) up to 8-9°C (summer) (Tepe, Rönnelid and Perers 2003).

The results of the simulations showed that the temperature to the evaporator in the reference case without solar collectors was slightly above 0°C. In the case of unglazed solar collectors the temperature to the evaporator ranged between 0-7° C (Tepe, Rönnelid and Perers 2003).

Simulations of the system with unglazed solar collectors were carried out to study the impact on the SPF for different values of the thermal conductivity in the bedrock. The SPF increased by around 0.2, when changing the thermal conductivity in the ground from 2.7 W/m, K to 4.4 W/m, K. By increasing the depth of the borehole, the SPF increased from 2.3 with the borehole of 65 m to 3.0 for the depth of the borehole of 185 m (Tepe, Rönnelid and Perers 2003).

The economy of the systems depends on many factors, and in the systems reported above, the unglazed solar collectors are most promising. An estimate shows that 50 m² unglazed solar collectors are cheaper to install than to drill 80 m deep, which gives roughly the same reduced need for the demand of electricity, with the conditions above. For the glazed solar collectors the demand of domestic hot water must be high, otherwise it is a questionable investment. For large systems the conditions changes, as many boreholes in the optimal configuration reduces the heat losses from the downloaded solar energy and the group of boreholes may function as a seasonal storage (Tepe, Rönnelid and Perers 2003).

Results from a field test in Uppsala in September 2002 - September 2003 was reported by Rönnelid and Tepe (2004). The system consisted of a 6 kW ground-source heat pump, a 125 m deep borehole and 13 m² glazed solar collectors. The building was a residential single family dwelling with 185 m² living area. The estimated heating demand was 16-18 000 kWh per year for heating, 5000 kWh per year for domestic hot water and 5000 kWh per year for the household electricity. The measurements for the first year were disturbed by several corrections in the regulation system. The evaluation of the system was also complicated as the demand of the domestic hot water was almost close to zero for almost 8 weeks in the summer of 2003. This means that solar collectors could not deliver the amount of energy during the summer that could be possible, and heat production from the solar collectors stopped at 243 kWh/m². The SPF for the plant was 2.83, compared with a simulated system without the solar collectors, which was estimated to 3.30. The conclusion is that the performance of the system can be improved significantly and that there is a need for careful control so the system may behave as planned. More testing will be required to verify the simulation results (Rönnelid and Tepe 2004).

Another project in Sweden, Anneberg, involves 50 residential units partly heated by 2400 m² solar collectors and a seasonal storage with 100 boreholes, 65 meters depth fitted with double U-pipes. The system was in operation in 2003, but technical problems with leakages have resulted in delays in the evaluation of performance (Lundh 2007). Although there were initial plans of using heat pumps in the system, the additional heat is delivered from individual electrical heaters.

In Sweden many small systems (mainly in single-family dwellings) with solar collectors and ground-source heat pumps have been taken into operation since 2000. As these systems are complex and specific, the evaluation is complicated and so far no measurement and evaluation of performance is recorded. One example is a system in a nature centre, Fulltofta, close to Ringsjön, in the south of Sweden, see Figure 3.7. The exhibition building is constructed with several environmental friendly features including solar collectors and ground-source heat pump. It was taken into operation in 2006 and is only using renewable energy for heating. The heat pump and to the other demand of electricity, is supplied with “green electricity”.



Figure 3.7 The solar collectors at the Fulltofta Nature Centre are mounted on the ground in order to give a signal to the visitors about the environmental concern of the building. This exhibition building is heated with solar collectors and ground-source heat pump. During winter time, wood is also used in a stove.

3.7 Summary of previous studies

Since the 70s there has been an interest in combining solar collectors and ground-source heat pump. Various experimental projects and simulations have been carried out over the years, but the prospects of the projects have been so different and the possibility of combinations so many, that general applicable results are still not available. There are few reported measurements with systems including solar collectors that can deliver temperatures directly to the domestic hot water system.

The result of the simulations that have been carried out are that the cheapest, unglazed, low-temperature solar collectors have the best economic potential in the combination with ground-source heat pumps. On the other hand, a more complex control strategy in systems with glazed solar collectors, has not been not simulated. Field tests have shown that for small systems it might be difficult with operations follow up and that the complexity may lead to a decreased efficiency.

4 Laboratory study of the heat transfer in water-filled borehole with different ground heat exchangers

This Chapter describes a laboratory experiment regarding heat transfer in different ground heat exchangers and especially the impact of free convection in the water.

In order to study the thermal resistance in the borehole with various ground heat exchangers, a laboratory study was accomplished during the 1996-1999 at the department of Building Physics, Lund University. The heat transfer between the heat carrier fluid and the ground depends on the arrangement of flow channels in the boreholes and the thermal properties of the material involved in the thermal process.

The heat flow between two surfaces is determined by the temperature difference and the thermal resistance. The main interest is the thermal resistance R_b between the heat carrier fluid in the pipes and the borehole wall. This thermal resistance is defined by:

$$T_f - T_b = q \cdot R_b \quad [\text{K}] \quad (1)$$

The temperatures of the fluid and the borehole wall are denoted T_f and T_b respectively. The heat injection rate q (W/m) is given per unit length of the borehole. Thereby the unit of thermal resistance R_b becomes K/(W/m).

The steady-state thermal resistance R_b depends on the convective heat transfer between the fluid in the pipes and the pipe walls, the thermal resistance over the pipe walls, the convective heat flow outside the pipes in the water (or ice for borehole temperatures below 0°C) or refill, and the conductive heat flow in the ground outside the borehole. In the case of a purely conductive filling material, the borehole thermal resistance can be calculated analytically (Bennet et al 1987; Hellström 1991). A particular complication is the combined conductive-convective heat transfer, if there is (liquid) water in the borehole.

The first preliminary results indicated that the heat transfer in water-filled boreholes will induce natural convection also at moderate fluid temperatures (20-35°C) and moderate heat injection rates (10-35 W/m).

The region outside the pipes in the borehole contained groundwater or a refill with higher conductivity in order to increase the thermal contact between the heat carrier pipes and the borehole wall. The local heat transfer in and near the borehole is very important for the heat transfer capacity of the ground heat exchanger. The overall borehole thermal resistance has a strong influence on sizing of the total depth of the boreholes, which is required to achieve a certain performance from the ground heat system.

The objective for the laboratory study was to examine the possibility to improve the heat transfer between the liquid in the U-pipes (the brine) and the wall of the borehole. A 3 m vertical section was studied and a steel-cylinder with double-walls simulated the bedrock surrounding the borehole, see Figure 4.1. The temperature in the “bedrock” was simulated with a cryostat-controlled circulating fluid inside the steel-cylinder (Kjellsson and Hellström 1999).

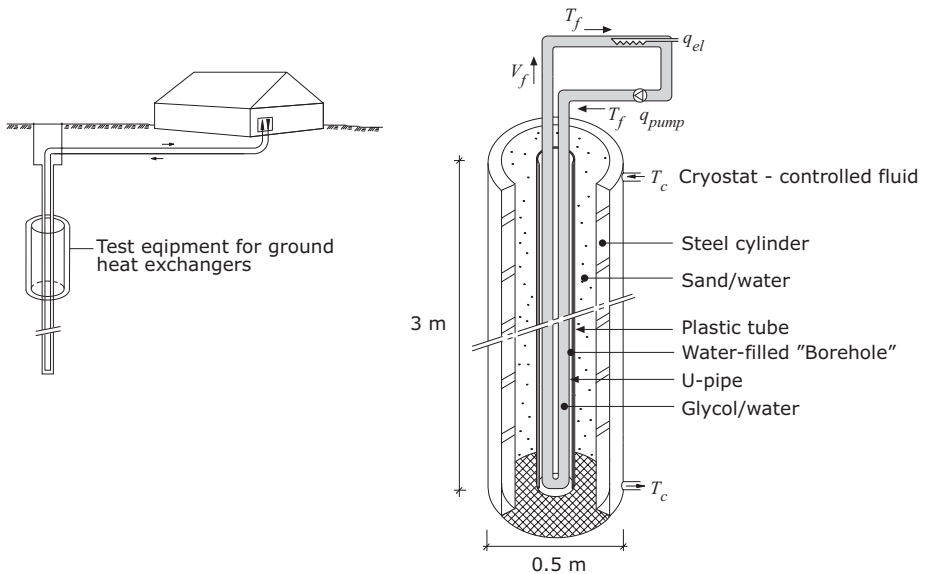

Figure 4.1. Laboratory test of ground heat exchangers.

Inside the steel-cylinder, the borehole was simulated with a PVC pipe and the volume outside the tube was filled with a mixture of sand and glycol/water.

For calibration of the laboratory installation one coaxial-pipe was tested. Here was the liquid in direct contact with the wall of the borehole. The experiment was performed with single U-pipes of polyethylene (PEM), 32 mm and 40 mm in diameter respectively. Also one single U-pipe of copper with 28 mm in

diameter was tested and an arrangement with double U-tube with 32 mm PEM-pipe was performed. Finally, a specially developed test prototype, consisting of 62 thin PEM-pipes inside the borehole wall was tested. The brine was pumped in the thin pipes down into the well and was in the bottom connected to one single PVC pipe in the centre for the outlet. This device was named C-pipe (Kjellsson and Hellström, 1999), see Table 4.1.

Table 4.1 Ground heat exchangers used in the laboratory study.

Test	Piping set-up	Material	Diameter	Comment
Co-axial				For calibration
PEM32	Single U-pipe	polyethylene	32 mm	
PEM40	Single U-pipe	polyethylene	40 mm	
PEM32x2	Double U-pipe	polyethylene	32 mm	
Cu28	Single U-pipe	copper	28 mm	
C-pipe	62 thin pipes arranged inside the borehole wall, concentric PVC pipe for outlet	polyethylene/PVC	3.8 mm	A test prototype

The temperatures were measured in the circulating liquid (the brine) in the test pipes, on the outside of the pipes, on the “borehole wall” and in the steel cylinder (“the bedrock”). Different temperatures in the “bedrock” were simulated and different heat injection was loaded into the brine. The influence of the pipe materials (polyethylene and copper) and the pipe geometry were studied for fluid temperature levels of 15 - 45°C and specific heat transfer rates of 50 - 100 W/m. The result of the measurements shows a substantial reduction of the borehole thermal resistance due to natural convection, see Figure 4.2.

Borehole thermal resistance

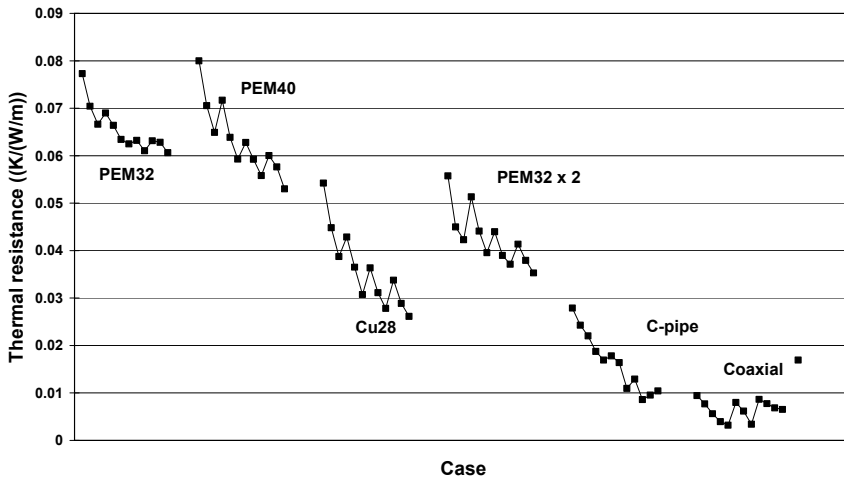

Figure 4.2 Measured thermal resistances in laboratory tests (K/(W/m)) (Hellström and Kjellsson 2000).

The variety of values in Figure 4.2 is due to the fact that the resistance was measured in 12 experiments for each installation, where the temperature in the cryostat (“the bedrock”) ranged from 0°C to 25°C in 4 different levels of temperature and the heat injection to the brine was varied with the three levels; 50, 75 and 100 W/m respectively. The **lowest values** of the thermal resistance for each of the experiments, were obtained for **high heat injection rate** (100 W/m) at **high temperature** in the borehole (35-40°C).

The borehole thermal resistance varied with the levels of heat injection for each tested case. This can be explained by the fact that a free convection in the water in the borehole influences the borehole thermal resistance. The higher the heat transfer is, the more impact has the free convection and thus improves the heat transfer, as the borehole thermal resistance decreases. The practical significance is that boreholes with water will get improved thermal properties compared with boreholes with fixed-filling, which is commonly used in countries outside Sweden (Hellström and Kjellsson 2000).

5 Components

This Chapter describes the different components in the combined system with ground-source heat pump and solar collectors.

5.1 The heat pump system

The heat pumps used for heating buildings in Sweden can be divided in outdoor air heat pumps (air/air or air/water), exhaust air heat pumps and ground-source heat pumps. In large systems in district heating network, sources like sewage water are also used.

A ground-source heat pump uses the ground (ground-source), ground-water or surface water as source of heat, and if used for cooling as “sink” for heat removed from the building in the summer. Cooling in dwellings is although not common in Sweden. Ground-source heat pump systems consist of three loops, except in the direct evaporating systems, where the refrigerant is circulating in the ground.

In the ground-water or surface water system, the water is directly cooled in the heat exchanger. In this open system, the water is discharged either to a surface water system, like a stream or a pond, or back to the underground through a separate well.

In the ground-source heat pump system, the heat is removed from the ground through a brine with a circulating, antifreeze solution. These closed-loop systems collect heat from the ground by horizontal or vertical piping in the ground. The antifreeze solution, which has been chilled by the heat pump’s refrigeration system to a temperature below the ground-temperature, circulates through the piping, absorbing the heat from the surrounding ground. Instead of an antifreeze solution the refrigerant can circulate in a direct evaporating system.

In the heat pump the heat from the ground is transferred to the refrigerant in the evaporator, see Figure 5.1. The refrigerant boils to a low-temperature vapour, which leads in to the compressor. Here the pressure increases, while the temperature also increases. The hot vapour then passes the condenser and the heat is transferred to the heating distribution system in the building and the vapour changes to liquid-phase. The pressure is still high and it passes the expansion valve. Here the pressure is decreased, which causes a decrease in the temperature. When the refrigerant passes the evaporator the liquid-phase

boils again and the process continues. The compressor needs energy and electricity is normally used in the Swedish systems.

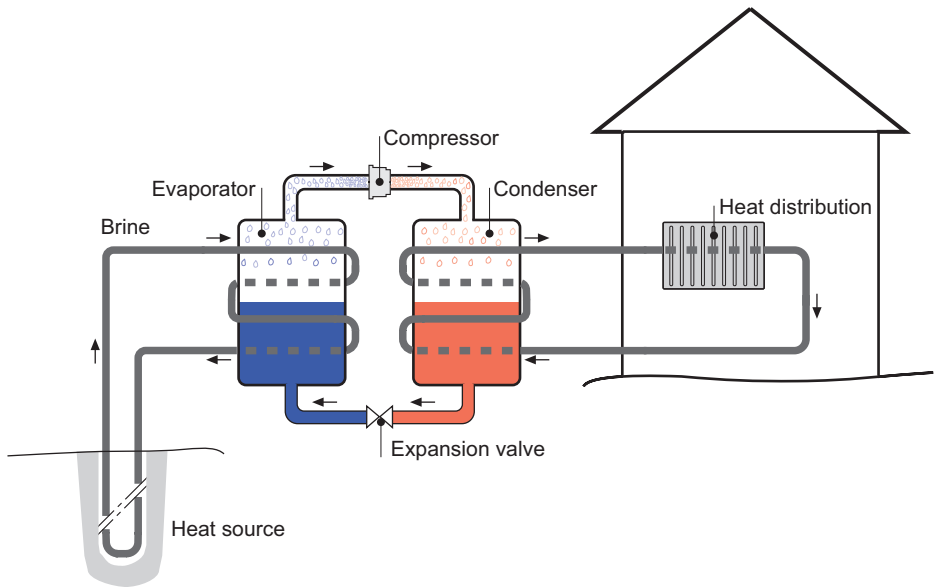

Figure 5.1 Principle of a ground-source heat pump.

The technique of heat pumps is not new, but the rapid growth of the market and the increasing environmental demands has put new requirements on the heat pump. The statistics from the insurance company Folksam in Sweden, report that the technology has not been fully tested and many damages are reported on new heat pumps (www.Folksam.se). Problems with the compressor is the most common one followed by the circuit card for the regulation and the reversing valve for the ground-source heat pumps installed between 1999-2006.

All types of heat pump systems can be used in combination with solar collectors, if the solar collector system can produce heat to the domestic hot water. The only system that is interesting for recharging is the ground-source heat pump with vertical pipes. It is of course also possible to use solar collectors in combination with horizontal piping but here the recharging is mainly natural as the pipes are closer to the surface with higher ambient temperature during summer time. If the heat extraction from the ground is higher than the natural recharging there is a possibility to recharge the ground

also with vertical piping. In ground-water and surface water systems there is no possibility to recharge as the water is not in a closed loop.

The design of a new heat pump system depends on whether it will part of an existing heating system or it will be a separate one. The latter case also includes domestic hot water heaters and an electrical heater, which automatically gives auxiliary heat when the heat pump is not sufficient during the cold days. Is there already an existing boiler, this may produce the auxiliary heat. What is important to take into account, when installing a heat pump in old dwellings, is that modern heat pumps for single family dwellings are normally designed for a low-temperature system in the building. This means that the design temperature of the condenser is often around 55°C and return-temperature 45°C, unlike the old heating system with the design temperature 80/60°C in the forward and the return pipes in the distribution system. In old buildings the radiators might be too small to maintain the desired temperature during the cold days.

In single family dwellings, the normal size of the installed ground-source heat pump covers approximately 50-70% of the maximum power load, which means that the heat pump accounts for approximately 85-90% of the annual energy requirements. In this case the heat pump is adapted to the total required heating demand in the building, and if this changes, the conditions of heat pump operation will also change. Depending on the building and the degree of insulation, the auxiliary heat will normally be needed when the outside temperature is less than about 0°C to - 5°C. However, there is a trend in recent years to install slightly larger heat pumps, which means that some additional minus-degrees can be covered. However, there is normally always a need of auxiliary heat during the coldest day of the year, which normally is the same day as for the peak load in the grid in Sweden. With buffer storage in the heat pump system, the heat pump could be shut down during the peaks.

The performance of a heat pump is often described with the COP, Coefficient of Performance, i.e. the relationship between the delivered heat and the input power (electricity). In catalogues with heat pumps, the values for the COP are given at different temperatures, such as 0°C to the evaporator and 35-50°C out of the condenser. The COP can in this application range between 3 and 5, depending on the temperatures on the hot and cold sides. A heat pump without losses could theoretically be able to reach up to a COP of about 6 at a temperature raise from 0 to 55°C (Perers 2004).

When comparing systems, COP does not describe the performance over a period and is normally not including other subsystems such as circulation

pumps etc. In this case, SPF takes not only one testing point into account, but also a period, e.g. a whole year. Also the rest of the system may be taken into account. SPF may describe the relationship between the supplied heat during the year, and use of all electrical energy in the system during the year. When making comparisons between systems, it may be uncertain what is included, for example, the electricity to the circulation pumps of various kinds.

The COP is primarily a result of the difference between incoming and outgoing temperatures in the heat pump, where small differences give high COP. The heat pumps for the single family dwellings are designed to operate optimally at normal existing temperature conditions. The COP for the heat pump for single-family dwellings can often be around 3. Electric power generated at the margin in Sweden, may come from coal-fired power plants from the neighbouring countries and the often used common primary-energy factor for marginal electricity is 2.5 (SOU 2008). From the environmental aspects of the use of heat pumps, it is important that the SPF is higher. The CO₂ conversion factor for the average electricity production in Sweden is 10 kg CO₂/MWh and for the marginal electricity between 400-750 kg CO₂/MWh (Elforsk 2008). On the other hand it is possible to use wind power to the electricity to the heat pump. Another environmental advantage is that it does not cause any emissions to the local environment where the heat pump is located.

The size of a conventional heat pump for single-family dwellings in terms of electric power may be from 1.5 kW_{el} (delivered heat around 4 kW) for dwellings with the energy demand of 20 000 kWh per year for hot water and heating, up to 2.5-3 kW_{el} (delivered heat 7.5 to 9.3 kW) of dwellings with the yearly demand 35 000 kWh. These figures assume the temperatures 0°C of incoming brine from the borehole and 45°C out of the condenser to the heating distribution system (Energimyndigheten 2006).

The price of a ground-source heat pump for a single family dwelling varies from 30 000 to 60 000 SEK without domestic hot water heater (including VAT) and about additional 10 000 SEK for heating of domestic hot water. The variation is mainly depending on the size but also on the type of additional equipment (Energimyndigheten 2006). The cost of installation is about 10 000 – 20 000 SEK and finally the cost of drilling will also be added.

5.2 Borehole and ground heat exchanger

The heat to a conventional ground-source heat pump is taken from boreholes. For single family dwellings it is normally enough with one borehole, but for

larger demand, several boreholes can be linked together. The depth of the borehole varies normally from 60 to 180 m, but deeper boreholes may also be drilled. A rule of thumb is that in the Stockholm area in Sweden, the need of borehole is about 20 m for each kW thermal output of the heat pump. The drilled depth depends on:

- heat load for the building
- thermal output for the heat pump
- thermal conductivity in the ground
- natural temperature in the ground
- distance to other ground-source heat pump systems
- depth of covering soil layer (down to the rock)
- ground water level and the ground water flow in the borehole
- geological conditions and drilling costs

In Sweden, the borehole (outside the U-pipes) is often filled with ground water but there are also other materials such as bentonite, concrete or mixtures with bentonite or concrete and quartz sand.

When sizing the depth, the required *active* borehole is calculated. The *active* borehole is the part of the borehole which is filled with a material with acceptable heat conduction, such as water or solid material. The heat transfer between the heat carrier fluid and the rock is negligible in the air filled part of the borehole. The distance between the ground surface and the ground water level can be large on hills or near tunnels.

The diameter of the borehole is usually between 114 and 140 mm, depending on the amount of energy needed for heating. In the borehole there is normally a collector consisting of one U-pipe heat exchanger with a circulating heat carrier fluid. In ground-source heat pump systems without solar collectors, the heat carrier fluid is normally an antifreeze solution with ethanol and water. The system is completely closed and is not in contact with the groundwater. However, in the ground-water heat pump system, the ground-water is pumped up from the borehole and is used directly in the heat pump. Normally, it is led back in the ground in another borehole or may be diverted by other means. With artesian water, a pump is not needed and the system is running by gravity.



Figure 5.2 Drilling a borehole to a single family dwelling.

Through the soil that is normally above the bedrock, a steel tube is lined 2 m down into the rock.

The U-pipe, inside the well, acts as a heat exchanger to the groundwater or the wall of the borehole. In order to provide the best heat transfer, the material should have a good thermal conductivity and the pipes should not be too thick. In addition, price plays a large role in the design of the heat exchangers. The material in the pipes is usually polyethylene (PEM) with the dimension 32 or 40 mm. Different pressure classes gives different thickness of the tubes, 2.0 to 3.7 mm.

Single U-pipes are the cheapest solution, but has the highest thermal resistance and does not fit into deep boreholes because of the large pressure drop, see Figure 5.3. Double U-pipes may be used instead in these cases.



Figure 5.3 Inlet of a single U-pipe in the borehole.

The cost of drilling a borehole is in the range of 20 000 to 60 000 SEK (including VAT). The price depends on the depth of the soil above the bedrock that will be lined with steel pipes, the depth of the well, the type of bedrock and soil. Marginal costs of additional casing pipes depends on the dimension and may in a normal system in a single family dwelling be 300 SEK/m, while the marginal cost of drilling deeper boreholes can vary between 150 to 250 SEK/m.

5.2.1 The brine in the ground heat exchanger

The brine is the fluid circulating between the borehole and the heat pump. In the ground-source heat pump system it is a closed loop. The brine is an anti-freezing liquid possible to use down to at least a temperature of -10°C without freezing. It should have a high specific heat capacity, a high thermal conductivity and a high density as well as a low viscosity, see Table 5.1. The environmental aspects are strong, as the liquid can leak into the ground if something fails.

Table 5.1 Thermodynamic data for different brines (Melinder 1997, Kylma 2000).

Brine	Freezing point (°C)	Thermal conductivity (W/m·K)	Specific heat capacity (J/kg·K)	Density (kg/m ³)	Dynamic viscosity (mPa·s)	Kinematic viscosity (mm ² /s)
Propylene-glycol 25% at 0°C	-10	0,450	3974	1026	5.51	5.37
Propylene-glycol 25% at 40°C	-10	0,486	3991	1010	1.37	1.35
Propylene-glycol 33% at 0°C	-15	0,416	3850	1035	8.17	7.90
Propylene-glycol 33% at 40°C	-15	0,445	3899	1015	1.74	1.72
Ethanol 24.4% at 0°C	-15	0,426	4288	972	5.85	6.02
Ethanol 30% at 0°C	-20	0,399	4170	966	6.49	6.72
VegoCool mixed at 0°C	-15	0,436	3320	1106	9.5	8.6
VegoCool mixed at 40°C	-15	0,488	3510	1090	2.5	2.3

The recommended and most commonly used brine in ground-source heat pump systems is a mix of about 30% ethanol and 70% water and the freeze protection in solar collectors is normally a mixture of 50% propylene-glycol and water. When combining solar collectors and ground-source heat pumps there are two possibilities regarding use of brine and collector fluid. One possibility is to keep the systems separated with heat exchangers and use the normally used mixtures. There are several brands available on the market. The disadvantage is that the system performance and the thermal efficiency are reduced with additional heat exchangers, as well as the costs are increased. The other possibility is to connect the systems without heat exchangers. In this case the liquid has to fit both in the solar collectors and in the ground heat

exchanger. The problem is that the ethanol mixture is not suitable to use in high temperature solar collectors, due to risk of explosion and that the propylene glycol may be regarded as toxically for the ground water and is not allowed to use in ground systems in many cities in Sweden. So far, a glycerol-based rapeseed oil-derivat, VegoCool has been used. This "rapeseed oil" is sold in ready-to use mixtures with a freezing point below -15°C and one advantage is that even if it freezes, there is no expansion of the volume, which can destroy solar collectors and other equipment.

As shown in Table 5.1 the specific heat capacity for VegoCool is lower compared to the mixtures with propylene-glycol and ethanol respectively, but is preferable to use in the ground for environmental reasons. Ethanol is not used in glazed solar collectors, as the temperature at the stagnation of the solar collectors can get over 150°C . The required amount of brine in a conventional system for a single family dwelling is 150 to 300 l (1 l liquid / m with 40 mm pipes).

In Sweden, the local Environmental office has to be contacted and informed before the start of a ground-source heat pump installation. This should include specification of the ground-source heat pump system and information regarding the brine. In areas with protection of the ground water, normally permission is also needed. There are differences between local regulations regarding the types of brine allowed in the ground heat exchanger.

5.2.2 The bedrock

The undisturbed temperature in the bedrock does not vary over the year, except in the upper level. The ground temperature is equal to approximately the average temperature over the year in the air, with an addition of 1.5°C for every 100 days with snow cover. The ground temperature increases with $1.5\text{--}3^{\circ}\text{C}$ per 100 meters of depth.

At 100 meters depth, the temperature in southern Sweden is around 10°C . In the Stockholm-area, the bedrock temperature is about 7°C , and in the north of Sweden down to 3°C , see Figure 5.4. This results in different conditions for a ground-source heat pump depending on the latitude.

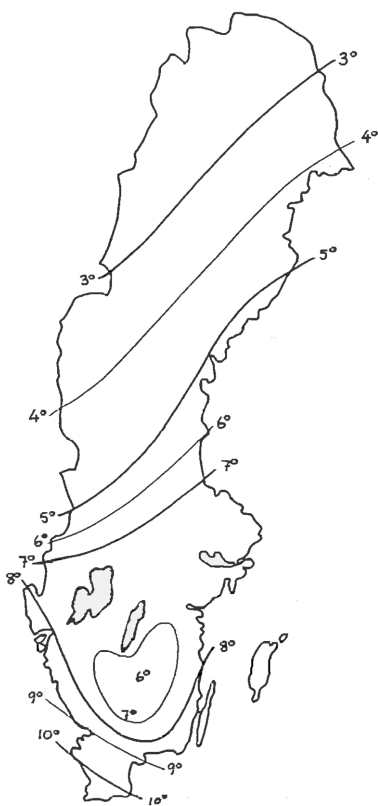

Figure 5.4 The temperature in the bedrock at 100 meters depth in Sweden.

The thermal conductivity varies with different rock and mineral compositions. The major part of Sweden's bedrock is composed of crystalline rocks, which has a relatively good thermal conductivity. Average for Sweden is about 3.5 W/m,K. Variations may occur within one rock-type and for granite is often an average of 3.4 W/m,K used, but the value can vary from 2.10 to 4.07 W/m,K. For gneiss is the average value is 2.9 W/m,K, but variations exist between 1.89 and 3.95 W/m,K. By comparison, the maximum value is for quartzite, with 6.0 W/m,K with a variation from 3.6 to 6.62 W/m,K (EED software). In Sweden such high values occur in Dalasandsten.

Ground water flow may lead to increased heat transfer in the borehole and the temperature during heat extraction from the borehole becomes higher than without ground water flow. The possibility of ground water flow is highly dependent on the local hydrological conditions in the close vicinity of the borehole. Information regarding these conditions is almost always missing as it

requires costly investigations of the ground. Normally the design of the boreholes is carried out with the assumption that all heat transfer in the ground takes place by heat conduction. The design is conservative in that regard. All ground water movements improve the performance of the system and in some cases significantly.

For boreholes with heat extraction without recharging, a low thermal conductivity in the bedrock results in a lower temperature, compared with bedrock with a high thermal conductivity. Solar recharging may compensate this.

5.2.3 Thermal influence

Heat extraction from boreholes cools down the surrounding ground and the cooled area increases with time. For a single borehole with ground heat exchanger this may be observed by the slightly decrease in the brine temperature during the 3-4 first years. Thereafter, the long-term decreasing in the temperature is small in comparison with the annual variation due to the heat extraction to the load; see Figure 5.5 (Hellström 2003).

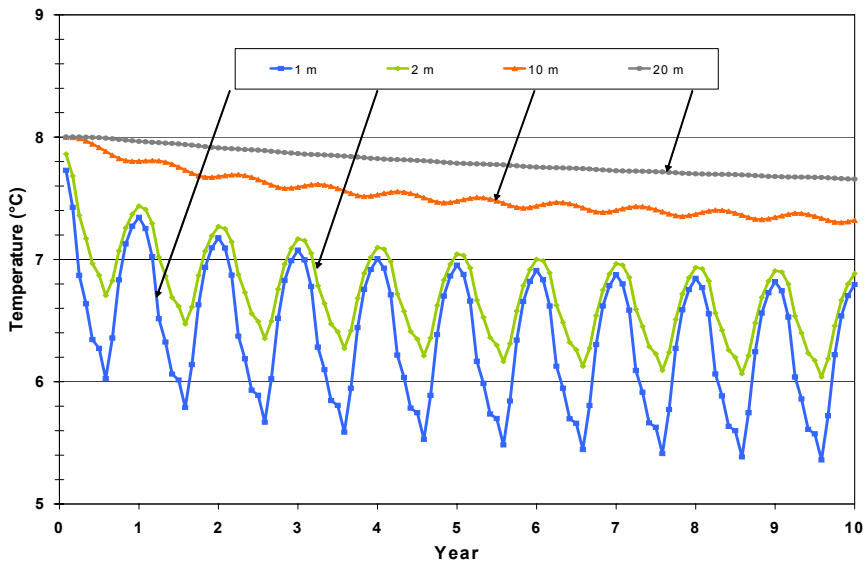

Figure 5.5 Examples of temperature variation in the surrounding rock during 10 years, at various distances from a single borehole with ground heat exchanger, extracting heat to a single family dwelling (Hellström 2003).

When several boreholes with ground heat exchangers are situated in the vicinity of each other, the cooling of the surrounding ground will lead to a mutual influence. This means that the brine temperature drops slightly faster compared to undisturbed boreholes. This may occur in areas with single family dwellings and can lead to undersized existing wells, if new wells are situated too close. In some cities there are restrictions regarding the distance between the boreholes and normally there is a recommendation of at least 15-20 m between the boreholes.

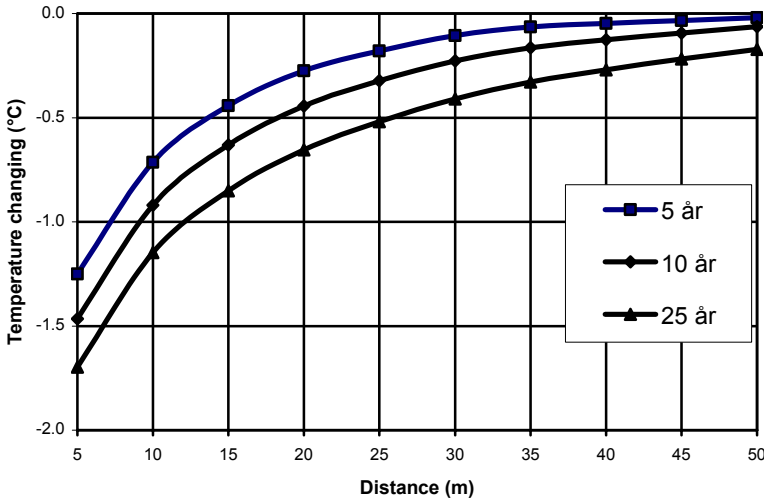

Figure 5.6 Example of changing in temperature in comparison with undisturbed borehole with ground heat exchanger, as a function of the distance to a nearby borehole after 5, 10 and 25 years respectively. The calculation applies to normal values for Swedish bedrock and shows the impact of a 90 meter borehole in another 90 meter borehole. Specifically design heat extraction 29 W/m borehole or 165 kWh/m/year (Hellström 2003).

Figure 5.6 shows the thermal influence on an undisturbed well, from the heat extraction from another borehole with a ground heat exchanger. The figure shows e.g. that the presence of a well of 20 meters distance results in a reduction of the temperature of 0.3°C after 5 years and 0.6-0.7°C after 25 years. Other nearby wells can provide the same type of contribution and the total additional decrease of the temperature from all the surrounding boreholes with ground heat exchangers, is the sum of all contributions.

5.3 The solar collectors

Solar collectors are normally used in dwellings for hot water production or in combisystems both for domestic hot water and heating the building. Unglazed collectors can be used for swimming-pool applications, but for higher temperatures glazed collectors are needed.

The conventional flat plate collector includes an absorber, where the solar energy is transferred to the heat carrier. The absorber is placed in a box with glass or plastic cover, with insulation under the absorber and at the sides of the box. Losses occur by multiple reflections in the glazing and in the absorber. When the absorber is heated up by the irradiation, the heat is transported to the heat carrier fluid. Heat losses occur from all heated parts and insulation is very important. See Figure 5.7.

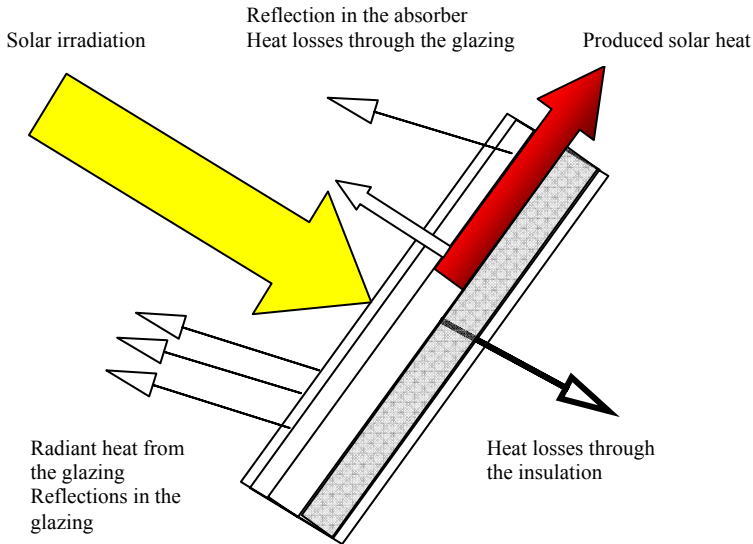

Figure 5.7 Optical losses and heat losses in a flat plate solar collector.

The thermal performance of a solar collector is dependent on its optical properties and insulation capacity. The efficiency is also dependent of the differences between the temperature in the collector and the ambient temperature, see eq. below.

$$\eta = \frac{q}{A * G} = F'(\tau\alpha) - a_1 \frac{(T_m - T_a)}{G} - a_2 \frac{(T_m - T_a)^2}{G} \quad (2)$$

η = Thermal efficiency of the solar collector

q = Power output from solar collector (W)

A = Solar collector area (in testing the aperture area is normally used – the area through which the solar radiation enters the solar collector) (m²)

G = Global irradiance on collector plane (W/m²)

$F'(\tau\alpha)$ = Optical efficiency, the combined efficiency of the transparent cover and the absorber ($\tau * \alpha$),

τ = transmittance for the glazing

α = absorptance for the absorber

a_1 = 1st order of heat loss coefficient at collector fluid temperature equal to ambient temperature (W/m², K)

T_m = Mean fluid temperature in the solar collector (K)

T_a = Ambient air temperature (K)

a_2 = 2nd order of heat loss coefficient, temperature dependent term of the heat loss coefficient a_1 (W/m², K²)

The difference in efficiency for different types of solar collectors increases with high temperatures. Figure 5.8 shows the principal efficiency for three types of solar collectors. There may also be large variations between solar collectors from different manufacturers.

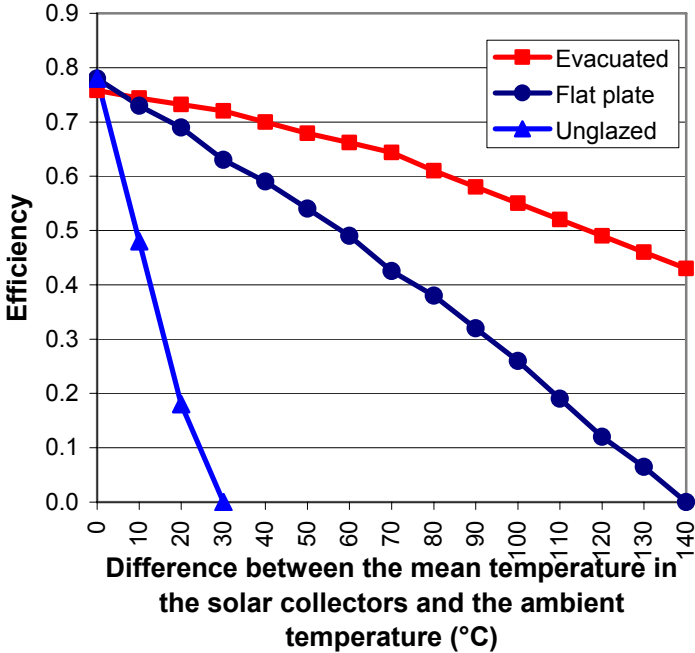

Figure 5.8 Example of efficiency for evacuated tube collectors, flat plate collectors and unglazed collectors at different temperature differences between the mean temperature in the fluid in the solar collector and the ambient temperature (Andr en 2001 and Solar Keymark homepage 2008).

An international certification system for solar thermal products is developed within Solar Keymark certification scheme. Solar collectors are tested according to European Standards (EN 12975 or 12976) and these collectors are certificated and receive a licence. The collectors are listed at the Solar Keymark homepage and the database with all certified collectors with the licenses is free to use for all. In Sweden, SP (Technical Research Institute of Sweden) issues the P-marking for tested and controlled solar collectors and the list of these collectors are also available at their homepage. The P-marking is also linked to the scheme for investment subsidies for solar collector systems, available in Sweden.

When combining solar collectors and ground-source heat pumps, the unglazed solar collectors can be used for charging the ground or increasing the temperature to the evaporator. The flat plate collectors and the evacuated tube collectors may be used as the unglazed collectors, but also directly for heating buildings and domestic hot water, when the heat pump is not in operation.

If the solar collector system and the ground-source heat pump have a common fluid system, the fluid must meet the requirements both from the environmental aspect when it is used in a ground-system as well as the aspect for explosion risk in a glazed solar collector, as discussed in previous section. The other possibility is to have heat exchangers between the systems and use the conventional fluids.

When the solar collectors are used to heat the evaporator in the heat pump, there is a high temperature limit in the heat pump, which will cause the heat pump to stop if the temperature exceeds the limit, in reality controlled by the pressure. There may be a shut-off function e.g. around maximum of 23°C to the evaporator. The temperature to the evaporator is often below 0°C in a ground-source heat pump system and the heat pump is designed for optimal performance for this operating conditions. Depending on design of the system, there must be an opportunity to decrease the temperature in the solar collector circuit before it reaches the evaporator.

Another limitation of the solar collector maximum power is that boreholes with ground heat exchangers have a limited capacity to cool the solar collectors. If the solar collector output is too high and the heat charges directly to a borehole which does not have enough cooling capacity, the temperature will raise in the solar collector system, with increasing losses and decreasing efficiency.

As both the solar collectors and ground-source heat pump systems require anti-freezing, there is normally at least one heat exchanger to separate these systems from the heat distribution system in the building. In an integrated system design, this heat exchanger is placed within the cover of the heat pump.

5.4 The circulation pumps

When solar collectors are combined with ground-source heat pumps, there is a need for several circulation pumps. In conventional solar collector systems the operating time of the circulation pumps is limited and so far cheap circulation pumps have been used. They have normally bad efficiency and the result from a test with 13 circulation pumps, made by the Swedish Energy Agency in

2007, was that the payback time for changing old circulation pumps to new, more efficient pumps, is only a few years in a heating distribution system (Energimyndigheten 2007b). One not earlier used circulation pump from 1970 with an efficiency of 4.9% was used as a reference pump. This pump was using 7 times more energy for circulating a heating distribution system 9 months/year, compared to the most energy efficient of the new pumps, and the double compared to the least energy efficient. So there is still a large variety in the efficiency in the new pumps, 7-25%.

The poor efficiency of the circulations pumps are also observed internationally and EU is encouraging the development in increasing the energy efficiency. There are competitions within Energy+ Award, regarding energy efficiency of circulation pumps. The EU-project “Energy+ Pumps” is a part of the “Intelligent Energy-Europe” working on introducing new, energy-efficient circulation pumps in heating systems (www.energypluspumps.eu). This is really an important issue in ground-source heat pump systems and if improved energy efficient circulation pumps are used in these systems, it will change the conditions for the operating time in systems with low energy yield, like recharging with solar heat.

5.5 Combined systems

The solar heat can be used in different ways in a system with a ground-source heat pump. The simplest way is to heat the borehole directly with solar heat. In this case, all kind of solar collectors can be used as the temperature in the system is low. The benefit in the system is increased temperature in the borehole and a decreased net heat extraction from the borehole. This can be positive for systems with thermal influence of neighbouring boreholes.

Another way of this system is to reverse the flow in the borehole. The solar collector will then heat the evaporator in the heat pump, during the time when the solar collector and heat pump is operating at the same time; otherwise the solar heat will heat the borehole as in the system above.

Another possibility is to link a conventional solar domestic hot water system to a ground source heat pump system. The solar collector produces heat to the storage tank for domestic hot water and the operating time for the heat pump is reduced, mainly during the summer. The solar heat decreases the use of electricity in the heat pump, as the operating time for the heat pump is reduced. The heat extraction from the ground will also decrease and the natural recharging increase.

A similar system is a solar combisystem, where solar heat also is used for heating the building. It requires normally a larger solar collector area and a storage tank, also connected to the heating distribution system in the building.

The most flexible system is when solar collectors can be used directly for heating domestic hot water, heating the house, heating the evaporator or recharging the borehole. The solar heat is used to the purpose of what is needed at the actual moment. The advantage is that it may save electricity to the compressor in the heat pump; the disadvantage is that it may also cause need of electricity to the circulation pumps.

An overview of different systems is shown in Table 5.2 and more information regarding the simulated systems is found in Chapter 6.4.

Table 5.2 Overview of considered systems with thermal solar collectors in combination with ground-source heat pumps and the effects in the system referring to the reference case without solar collectors.

System	Effect on the solar collector	Effect on the heat pump	Effect on the borehole
1. No solar heat - Reference case – a conventional ground-source heat pump system.	No solar collector	All heat production from the heat pump	Only natural recharging
2. Solar heat to the borehole passing the heat pump, increasing the temperature to the evaporator, when the heat pump is in operation	Production of solar heat at a low temperature (5-20°C) gives high efficiency and long operation time for the solar collector	Increased COP and decreased operating time	Recharging of the borehole with solar heat gives increased temperature in the borehole, or possibility of using shorter borehole
3. Solar heat direct to the borehole (This system was not promising and only a few simulations were done.)	Production of solar heat at a low temperature (5-20°C) gives high efficiency and long operation time	Increased COP and decreased operating time	Recharging of the borehole with solar heat gives increased temperature in the borehole, or possibility of using shorter borehole
4. Solar heat to domestic hot water (and heating system in the building)	Conventional solar collector system. Solar collector temperature >50°C.	Heat pump may be shut off during summertime	No or decreased heat extraction during summer
5. Combination of system 2 and 4. Solar heat to domestic hot water system during spring-autumn, and to the borehole, passing the heat pump during winter (or other times)*	Solar heat production directly when it is possible, short time recharging, saving electricity to the pumps	Increased COP and decreased operating time	No or decreased heat extraction during summer and increased temperature in the borehole due to recharging during winter, or possibility of using shorter borehole
6. All solar heat to a brine tank connected to the heat pump and the borehole	Increased temperature compared from the borehole, which decreases the efficiency	Increased temperature compared from the borehole, which increases the COP	Recharging of the borehole with solar heat gives increased temperature in the borehole, or possibility of using shorter borehole

*In the simulation performed (see also Chapter 6.4 and under 7 Results of the simulations) the system 5 was simulated: Solar heat to domestic hot water system during March – October, and to the borehole, passing the heat pump during November to February.

6 Simulations

In this Chapter describes the simulation program TRNSYS, the used components in the simulations and the simulated systems.

6.1 TRNSYS and Simulation Studio

To simulate the combined system with solar collectors and ground-source heat pumps, the simulation program TRNSYS (Transient Systems Simulation Program) has been used (Klein et al. 2006). TRNSYS is a complete and extensible simulation environment for the transient simulation of systems. It started to be developed in 1974 by the Solar Energy Laboratory at the University of Wisconsin, USA, and has since then been developed continuously. It is widely used by engineers and researchers around the world to validate new energy concepts, like various solar collector systems for heating and domestic hot water but also for design and simulation of buildings and installations, including control strategies, occupant behaviour, other alternative energy systems (photovoltaic, wind and hydrogen systems), etc.

One of the main advantages with TRNSYS is the open modular structure, which gives the possibility for a flexible structure for different systems. Components are available as separate modules that are connected together via inputs and outputs. They are linked together in order to solve a specific task. A simple solar collector system may include e.g. solar collectors, storage tank, auxiliary heat, a pump and several temperature controls. The performance of the system depends on a load, which is dependent on time due to weather conditions, domestic hot water load, internal load and demand on comfort for heating, cooling and ventilation.

TRNSYS is programmed in Fortran and the source code of the kernel as well as the component models are delivered to the end users. This makes it possible to extend existing models to make them fit the users specific needs or to create own modules if the desired component is not available in the program library. This flexibility gives the possibility to study systems or system components in detail. The disadvantage with the high flexibility and the great level of detail is that modelling of systems is time demanding and requires good knowledge of both the program and the physics of the system to be simulated. A large number of parameter values have to be handled with carefulness in order to prevent errors.

TRNSYS has the capacity to simulate the whole energy flow with the basis in the climate (wind, temperature and solar irradiation), heat losses, transmission

losses, ventilation, domestic hot water and demand of cooling. For modelling the components, also called Types, it is necessary that the mathematical model is describing the performance in a realistic and well adapted way. The component describing functions in systems have been developed, validated and been used during a long time of a large number of users, all of the world. New components are added subsequently.

TRNSYS distinguishes between input, which can be time dependent and parameters, which are constant through the whole simulation. All input and parameters must have a given value, either a constant through the simulation or a value given from another component. The output is the result from the internal calculations in the component module and is used as input in other components. Each module is defined by a number of properties that are given in the parameters. For a solar collector this may be the area, heat loss factors etc. The corresponding for a ground heat exchanger is borehole depth, radius, thermal conductivity, heat capacity, fluid properties. The Type for a ground heat exchanger used in the simulations is described by 33 parameters and 5 inputs.

In TRNSYS, the components are calculated in subroutines of the main program and are solved separately and sequentially. They are calculated one after the other and this is a difference to other component-based simulation programs where all equations are solved together at once. In TRNSYS, the result of the output from one component is given to the next component. If input has not been calculated as output, from the component for the actual time step, the value from the previous time step is used. If the components form a loop, where input from at least one component depends on the output from the same component, the equations are solved by iteration. A convergence tolerance limit value, which is defined by the user, defines the maximal number of iterations and the accuracy of the calculation results. The process with the calculation of all components continues until all components and loops have been completed. If a loop is not converging within the tolerance limits, the last value is saved and a warning is printed. If too many warnings arise in a simulation, it will be terminated and has failed.

The convergence tolerances influence the consistency of the result within a loop and so also the energy balances. A tight tolerance limit leads to a more consistent result, with small errors in the energy balances, but on the other hand demands more number of iterations and computational time. It is a compromise between accuracy in the result and computational time and in general it is necessary to check the simulation results carefully and compare them with measurements and/or separate calculations. A limitation of

TRNSYS is that systems can only be simulated with a fixed time step (Persson 2006).

There are possibilities to control the simulation by checking output and compare the performance of a real system under the same conditions. It may be done either by checking the total energy flows and energy balances in subsystems or by following the dynamic process in the system. This can be done with an “on-line plotter”, which on the screen draws the output that might be of interest to follow, e.g. temperatures, flows, operation of controls, pumps etc (Weiss 2003).

Together with TRNSYS there is a number of supporting programs for facilitating the use. In this study the TRNSYS version 16.01.0002 is used together with the user-friendly interface program Simulation Studio 2006, version 4.2.0.30. In Simulation Studio, the components are linked together and the input and parameters are given. For simple systems it is very illustrative and easy to follow and there are several functions for using different colours or layers to distinguish between different types of connections like hydraulics, controls, weather or output.

By using TRNSYS as simulation tool, this study follows up earlier work with the combination of solar collectors and ground-source heat pumps in Sweden (Kjellsson 2004, Tepe et al 2003) as well as other studies of the combination of solar collectors and other energy sources.

6.2 Components used in the simulations

In order to simulate systems with solar collectors in combination with ground-source heat pumps, a simulation deck including up to 65 units was built up. These units are representing all the components in the simulated systems and are in TRNSYS described with different Types. A Type can describe a system component like a pump or a printer, as well as include files with weather data, performance of the heat pump or the load for domestic hot water. Totally 46 different Types are used in the simulations. Some internal input and output has to be calculated in order to receive the requested result and this is done in 11 special “Equation” units, including a unit for changing of parameters. For checking the result on the screen 7 plotters are connected and finally a control card is used to set the global information like simulation time, simulation time step, tolerance integration and tolerance convergence. Here are also the settings for the acceptable number of warnings. An example of the used simulation deck with the main components, is shown in Figure 6.1.

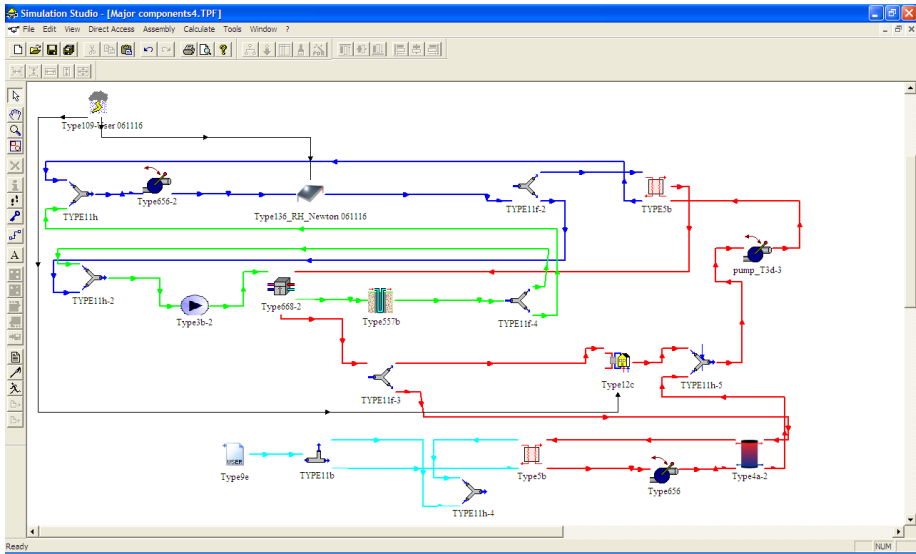

Figure 6.1 Main components (Types) and system used in the simulations.

The major components and input files in the simulation of the system are:

- Solar collector
- Thermal storage
- Heat pump
- Ground-source heat exchanger
- Weather
- Building load
- Domestic hot water load

6.2.1 The weather model

The component for the weather data in the simulation is Type 109, Combined data reader and solar radiation processor. This type reads the weather data at regular time intervals from a data file and converts it to a desired system of units. It generates direct and diffuse radiation output on an arbitrary number of

surfaces with arbitrary orientation and inclination. In this simulation it is used with a user-defined format fitting to the used solar collector type.

In Type 109 four different models for calculation of diffuse radiation on tilted surfaces are available and the chosen model is the Perez diffuse radiation model. This model is usually considered to be the best available model and it accounts for circumsolar, horizon brightening and isotropic diffuse radiation by empirically derived “reduced brightness coefficients” (Klein et al 2006).

In the simulations, Type 109 gives input to the solar collector and to the heating demand in the building. The used weather files are obtained from Meteornorm weather files, added with output for long wave radiation in order to use the same system for simulation of unglazed solar collectors.

6.2.2 Solar collector model

The used solar collector model for flat plate collectors is Type 136 (RH Newton 061116), which is an extension from the solar collector model used in the standard EN12975. Type 136 is developed from Type 132 in TRNSYS 15 and includes condensation, long wave radiation and wind (Perers 2006). The reason for using this model is that also simulations with unglazed solar collectors have been performed, but this is not included in this report.

A few simulations were also made with evacuated tube solar collectors, with the Type 538 developed by TESS (Thermal Energy System Specialists, Wisconsin US), but these results are either not included in this report.

6.2.3 The heat pump

Type 668, developed by TESS, is a model for a single-stage water to water heat pump. The model is based on user-supplied data files containing catalogue data for the capacity and power demand, based on the entering load and source temperatures. Type 668 operates with temperature level control and may be used either for heating or cooling. When the user defined control signal indicates that the unit should be ON, it operates at its capacity level until the control signal values changes (Mitchell and Braun 1997). Type 668 is able to interpolate data, within the range of input values specified in the data files, but it is not able to extrapolate beyond the data range and will print a warning in the TRNSYS list file and simulation log if conditions fall outside the data range.

In order to simulate different sizes of heat pumps, the data file was scaled down proportionally. This is an approximation as larger heat pumps may be

slightly more efficient, but the used changing of sizes was not considered to be so large so this would influence on the result.

6.2.4 The ground heat exchanger

The vertical ground heat exchanger model, Type 557, is the most commonly used model in ground-source heat pump applications. In the performed simulations it is used with one U-tube ground heat exchanger, with the heat carrier fluid circulating in the U-tube. Normally there is one U-tube per borehole but the model allows the user to have up to 10 U-tubes per borehole. The program assumes that the boreholes are placed uniformly within a cylindrical storage volume of the ground. There is a convective heat transfer within the pipes and conductive heat transfer to the storage volume. The temperature in the ground is calculated from three parts, a global temperature, a local solution and a steady-flux solution. The global and local problems are solved with the use of an explicit difference method. The steady state flux solution is obtained analytically and the temperature is then calculated using superposition methods (Klein et al 2006). The subroutine at the heart of Type 557 was originally written by the Department of Mathematical Physics in Lund University (Hellström 1982).

6.2.5 The thermal storage

In order to keep the numerical stability during the simulations, the stratified storage tank model Type 4 was chosen. It is a multi-node fluid storage tank with 2 optional internal auxiliary heaters. The model provides a very good accuracy and still keeping the parameter complexity and the computational effort reasonable. This is the most used tank model in TRNSYS standard library (Klein et al 2006).

In the simulations, the Type 4 tank was used as a tank for domestic hot water with an external heat exchanger for the tap water. Type 4 was used without any internal heat exchangers. Several tests were made with the more complex Type 60, but the system became instable and fragile. This made it not suitable for a variety of complicated systems including heat pump and ground heat exchanger, especially as the simulation time was normally 20 years, in order to see the changes of temperatures in the ground.

6.2.6 The building load

In TRNSYS there is a detailed multi-zone building model available, Type 56. This component models the thermal behaviour of a building having up to 25 thermal zones. As the objective in the present case was to investigate the

difference between systems, a simple degree-day model was chosen instead, Type 12c. In this Type, the space heating load estimates the hour by hour heating load of a structure, using minimal computational effort. The used mode models a single lumped capacitance house, compatible with temperature level control. The overall conductance for heat loss from the house is given as input and the thermal losses are calculated by:

$$Q_{loss} = UA * (T_{house} - T_a) - Q_{gain} \quad [W] \quad (3)$$

Q_{loss} = Conductive heat loss from the house (W)

UA = Overall conductance for heat loss from the house (W/K)

T_{house} = The temperature in the house (K)

T_a = The ambient temperature (K)

Q_{gain} = Internal gains (W)

The overall conductance is given a parameter value, as well as the house thermal capacitance and by varying these values, different “sizes” of the building is simulated. The thermal capacitance of a building is the effective heat capacity of a structure per unit change of interior temperature. The effective heat capacity is the sum of the products of mass, heat capacity and temperature changes of all the elements in a building:

$$C = \sum (m * C_p)_i \Delta T_i \quad [J] \quad (4)$$

C = Effective building thermal capacitance (J)

m = Mass of the building element (kg)

C_p = Heat capacity of the building element (J/(kg,K))

i = element i

ΔT_i = Temperature change in the element i (K)

6.2.7 The domestic hot water load

A data reader, Type 9e, was used to read the data file with the domestic hot water profile. One-hour data was used in order to simplify the simulations. The total demand for a year was around 3400 kWh. More detailed data files with

small time steps were tested (6 minutes), but the computer time was slowed down and as the scope for simulation was not dealing with details in the solar collector system, the one-hour data was sufficient to use.

6.3 The simulation – background aspects

One output of the simulation was to find the maximal use of solar energy defined as decreased use of electricity in systems with solar collectors compared to systems without solar collectors, se Figure 6.2. In order to make the comparisons between systems it is necessary to use the simple and robust models and only change as little as possible between the simulations.

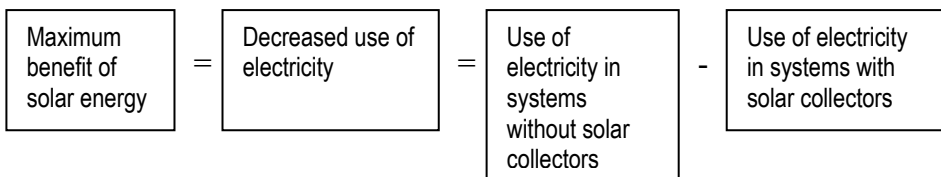

Figure 6.2 Defining of the benefit of solar energy in the simulations.

The start was to define the reference case, which is a single-family dwelling with a typical energy use for Sweden and a correctly dimensioned ground-source heat pump system. The energy demand corresponds to an average building today using oil or biomass, which is likely to install a heat pump, which means a heating demand exceeding the average for a single-family dwelling. The relatively high investment costs for a ground-source heat pump system makes it most interesting to install in buildings with a relatively high heating demand. The sizing of the heat pump and the borehole depends on the energy demand, the operation time for a year of the heat pump, as well as the temperature in the borehole.

When adding solar collectors this may be done in different systems, with different types and sizes of solar collectors and in order to get a comparable result the changes between each simulation must be reduced.

In order to check that the simulation is working properly it is possible to follow the detailed dynamic behaviour of the system with on-line plotters. All outputs and also results in equations can be linked to on-line plotters and subsystems may be checked and compared to real systems. The time scale can be varied and the plots may be enlarged and resized to the users demand.

All simulations were made with the same program versions and with the same computer.

There are a number of simplifications and assumptions that are built in the simulation in order to achieve a manageable system in TRNSYS and to have reasonable simulation time. For one simulation the needed computer time for 20 years was about 30 minutes (about 14 million time steps) with the used computer (997 MHz). The results from the simulations of the combined systems are dependent on a large variety of parameters. The used models of the simulated types in TRNSYS are validated. In order to get comparable results between the systems, only a minimum numbers of parameters were changed between the simulations. This means that there are excellent possibilities to investigate different parameters, but when comparing with other systems, e.g. realised projects, there might be other factors like control systems etc., that can influence the result. The parameter of major interest, the depth of the borehole, is not possible to change in a given system in reality, but in the simulations this can be compared in all systems.

6.4 Simulated systems

6.4.1 The reference case – system 1

Figure 6.3 shows the principle of the TRNSYS deck of the reference case.

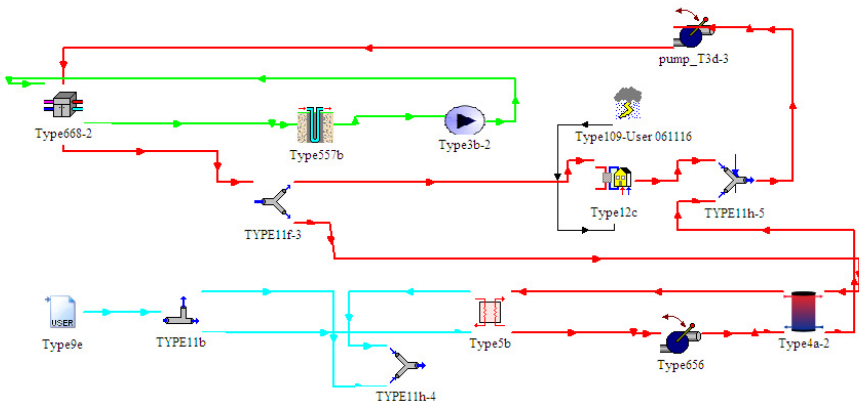

Figure 6.3 The principle TRNSYS layout of the reference system 1.

The reference case is a system with a ground-source heat pump in a single family dwelling. The heating load is about 26 000 kWh/year and the domestic

hot water demand about 3400 kWh/year, totally about 29 400 kWh/year. The area of the building is not stated – it may be a building with a high specific energy demand less than 150 m² or it may be a large, energy efficient building. The parameter for the heating demand is given as the overall conductance 250W/K. The building thermal capacitance is 10 GJ/K.

The average use of energy for heating and domestic hot water in single family dwellings in Sweden heated with oil or biomass, is around 200 kWh/m² (incl. boiler losses) and it is most likely those buildings that are subject to install ground-source heat pumps. The heated area may be from 150 m² and larger, depending on the energy efficiency and the selected values represent a typical building.

The statistic average for heating of domestic hot water in all single-family dwellings in Sweden is 3600 kWh/year, with 2.6 persons as average in the household.

The climate in the reference case is weather data from Stockholm and a user-defined Meteororm-file is used as the input file.

The input file for the heat pump is data for a conventional Swedish heat pump, scaled proportionally for the different sizes. A conventional sizing should be around 7 kW (delivered heat) (Energimyndigheten 2006). Simulations were conducted for 7 kW, but also for 6 and 8 kW respectively.

The borehole is varied between 60 and 160 m and the temperature in the borehole during operation of the heat pump was followed.

The reference case includes no solar collectors (see Figure 6.4), and the result is compared with different systems with solar collectors.

The systems were simulated for 20 years in operation and in order to have reasonable simulation time, the time step used was 7.5 minutes (0.125 hour). The error tolerance both for integration and convergence was 0.001.

In order to get comparable results between the different systems, as little as possible was varied. The same size and type of solar collectors were used in all systems, but the size of the storage tank was different between systems using solar heat for domestic hot water compared to systems without solar heat to the domestic hot water. Also the flow in the solar circuit was different between these systems.

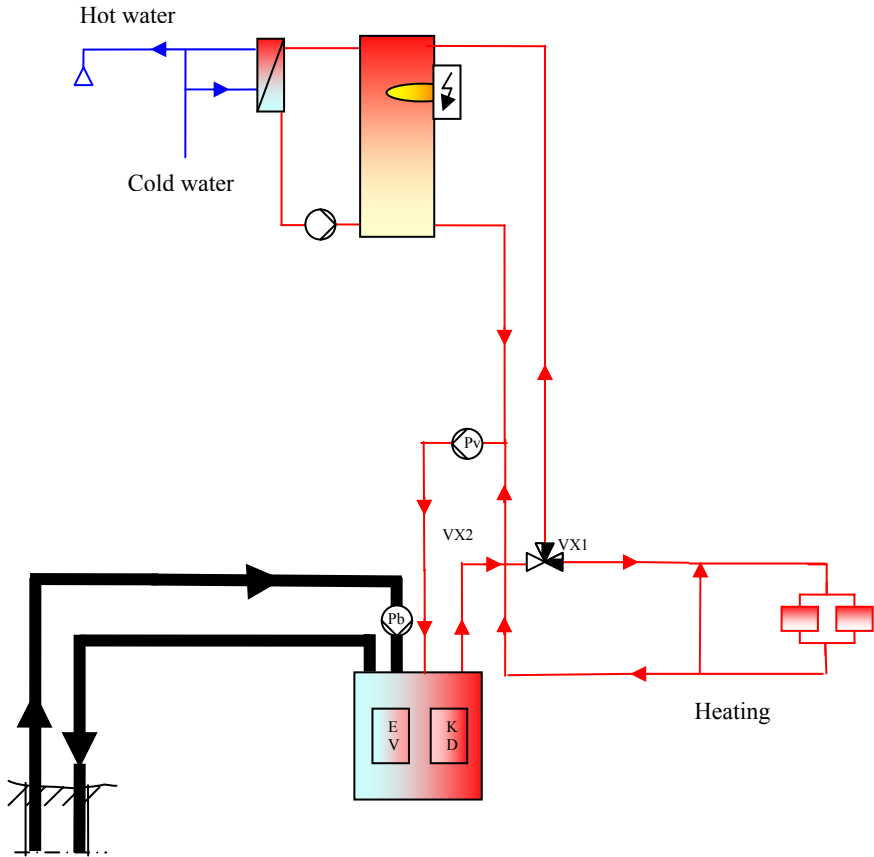

Figure 6.4 Reference case – ground-source heat pump without solar collectors.

6.4.2 All solar heat to the heat pump and the borehole – system 2

In order to investigate the maximal influence of recharging of the borehole, all solar heat in system 2 was directed to the borehole, Figure 6.5. To get comparable results with systems using solar heat for domestic hot water, conventional flat plate collectors were chosen. This means low operation temperature in the collector, between 0°C and up to 20°C . Condensation has not been included in the simulations. The heat pumps are normally constructed so they are shut off when the temperature increases e.g. above 23°C . In the

simulations this has not been taken into account, as it is unlikely to appear in this system.

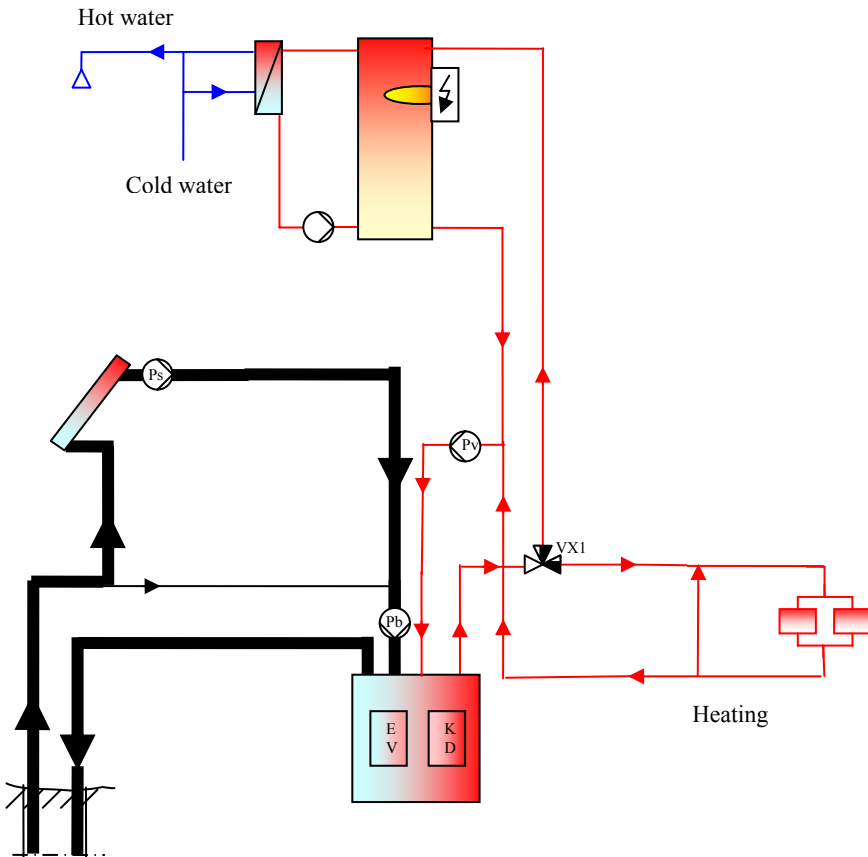

Figure 6.5. System 2 with all solar heat to the borehole, passing the heat pump.

In Figure 6.6, the temperature in and out of the heat pump is shown for a day in August. When the temperature increases in the system depending on as well increased ambient temperature as well as solar irradiation, the temperature to the evaporator increases and the delivered power from the heat pump increases. When the ambient temperature rises, the heating demand in the building decreases.

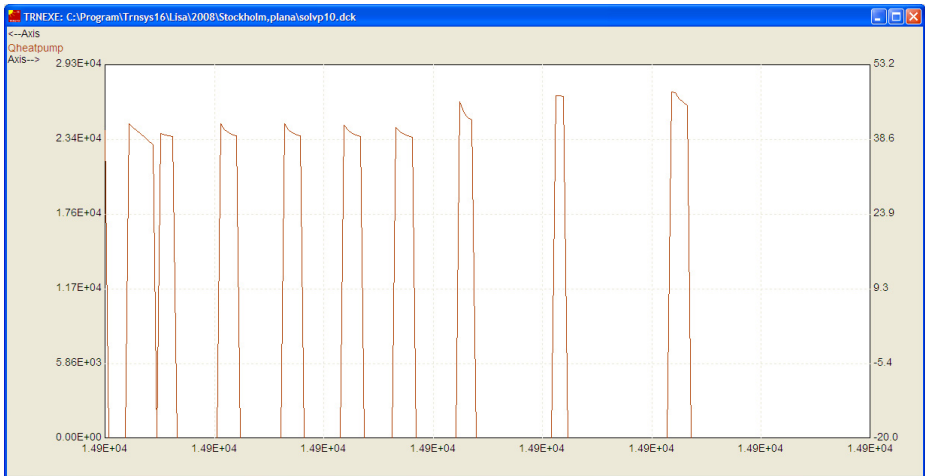
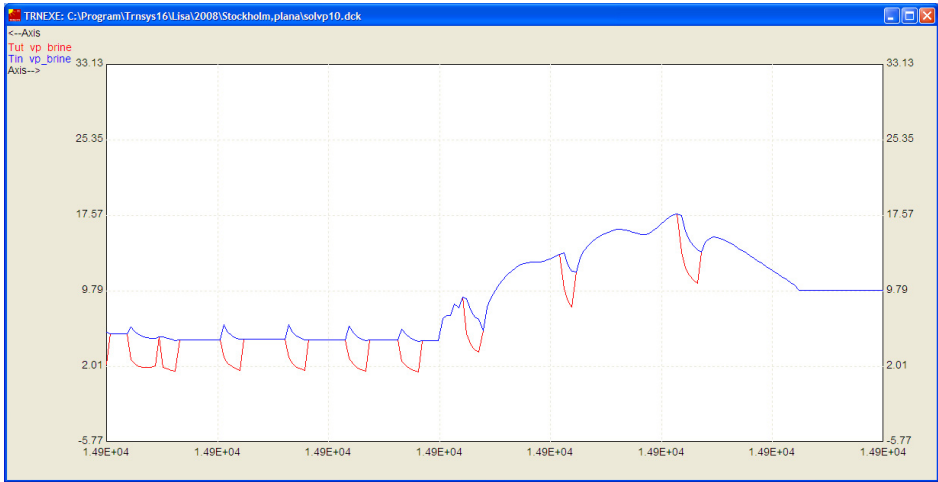

Figure 6.6 Temperatures in (upper curve) and out (lower curve) of the heat pump (upper diagram) and delivered heat power from the heat pump at the same time (lower diagram), a day in August in a system with 10 m² solar collectors recharging the borehole, 140 borehole depth and 6 kW_{heat} heat pump. The period is the number of hours from simulation start (14900-14924).

6.4.3 All solar heat direct to the borehole - system 3

Instead of connecting the solar collectors directly to the heat pump another possibility is to bring the solar heat directly to the borehole, see Figure 6.7. This is often proposed by the manufacturers in order to protect the heat pump from high temperatures.

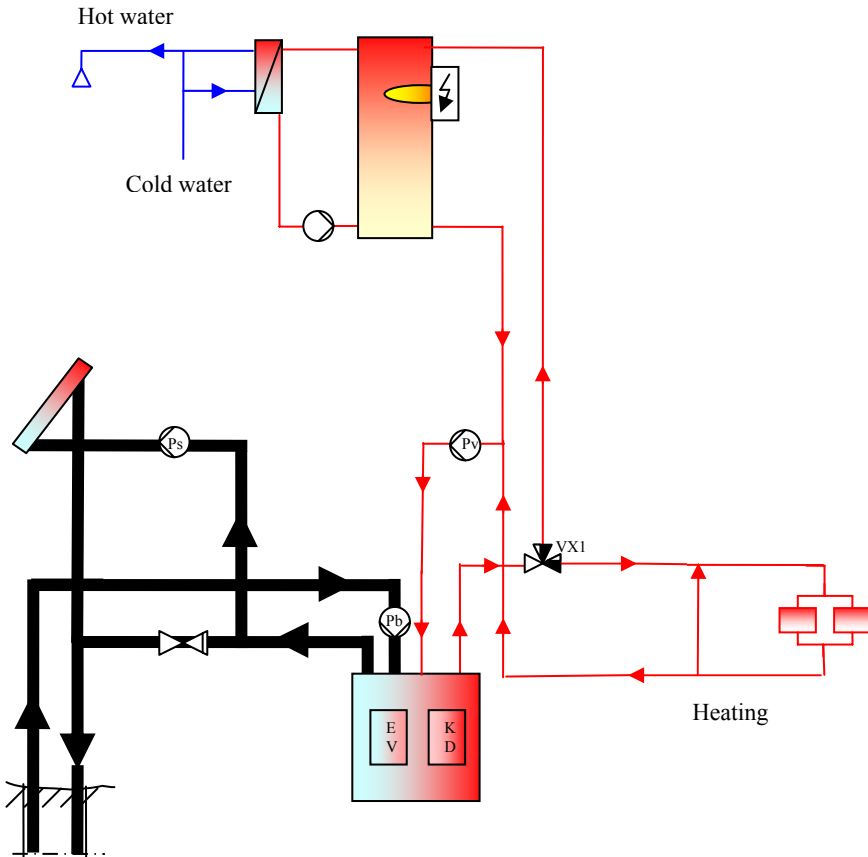

Figure 6.7 System 3 with all solar heat directly to the borehole.

6.4.4 All solar heat to the domestic hot water – system 4

In system 4, the solar collectors are connected to the storage tank, as a conventional solar collector system for domestic hot water, see Figure 6.8. In this system, the operation time of the heat pump is reduced during summer and the borehole is recharging naturally from the surroundings. The heat pump covers the whole heating demand and operates as auxiliary heat to the domestic hot water, when the solar collector can not cover the demand to the domestic hot water.

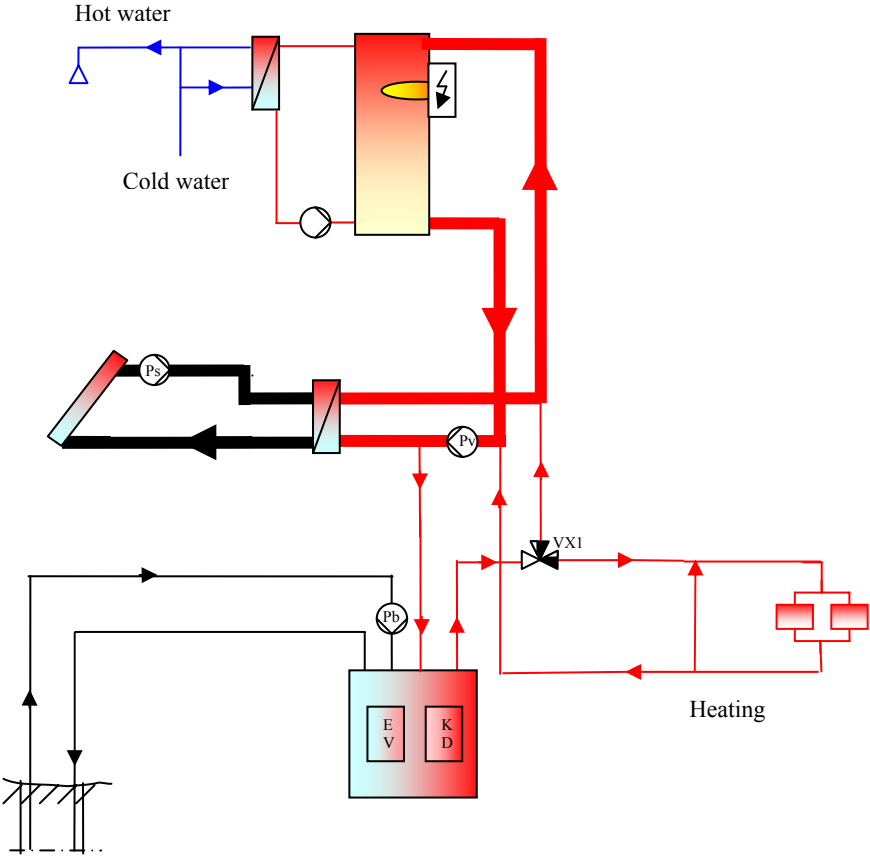

Figure 6.8 System 4 with solar heat to the domestic hot water.

6.4.5 Solar heat to the ground and to domestic hot water – system 5

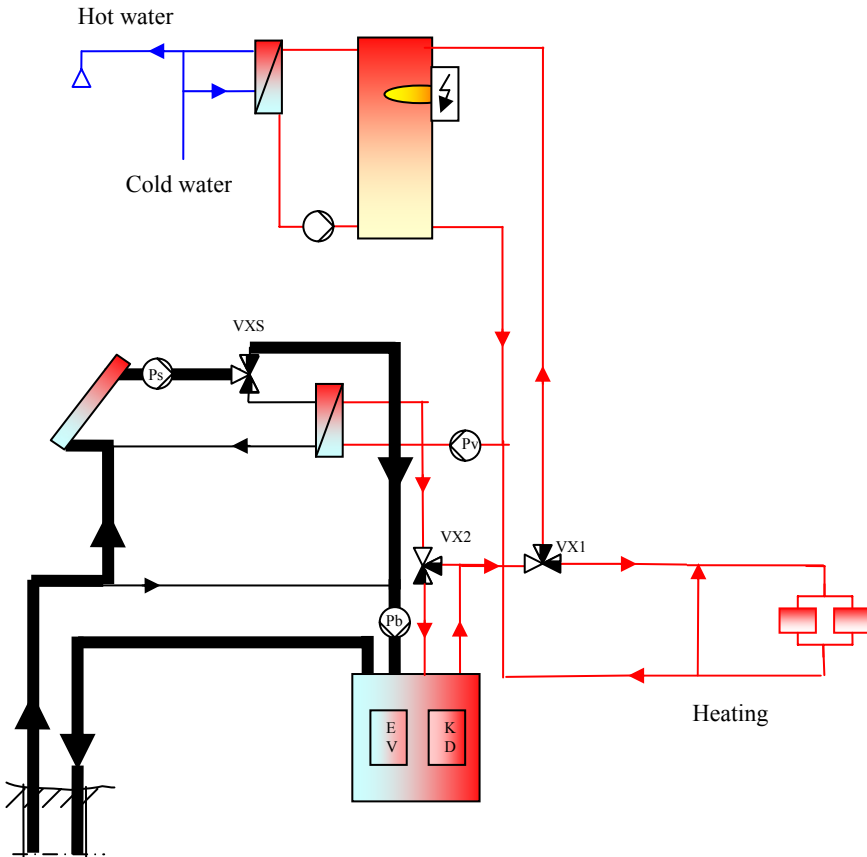

Figure 6.9 System 5, with flexibility - operation mode 1: solar heat to the ground, or the evaporator when the heat pump is in operation.

In system 5, there are possibilities to use the solar heat to recharge the ground, to increase the temperature in the evaporator and to use it for domestic hot water. The solar collector system and the borehole system are linked together in one common system. There are two modes of operation, depending on the season, see Figures 6.9 and 6.10.

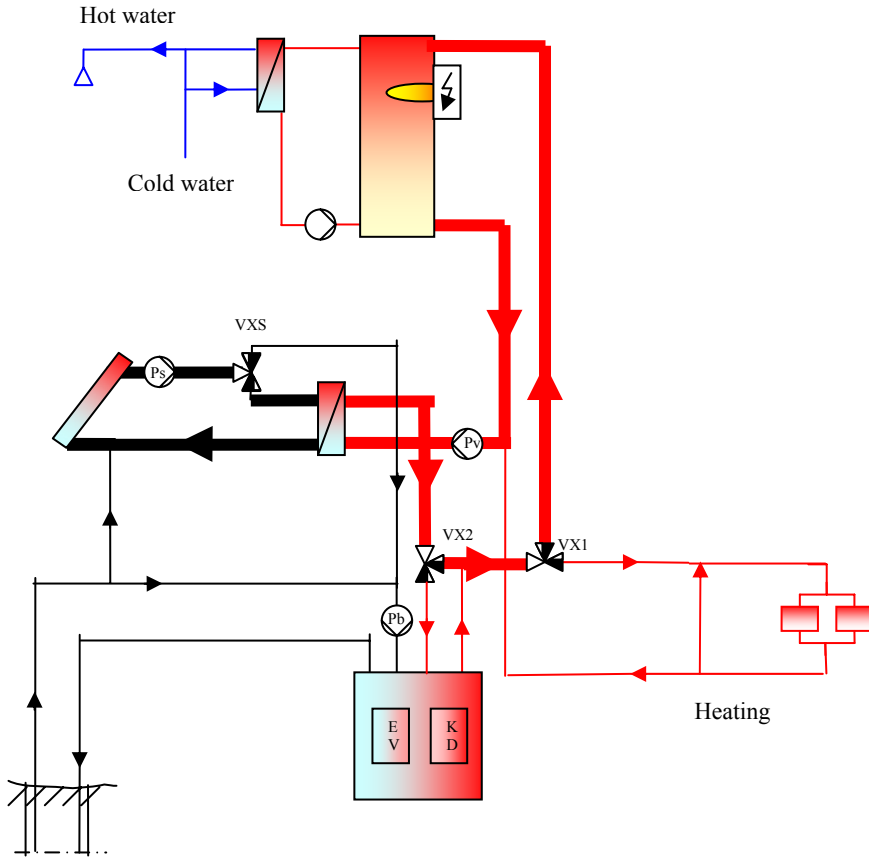

Figure 6.10 System 5, with flexibility - operation mode 2: solar heat to the domestic hot water.

In the simulated system, the two operation modes are switched between manually, so in wintertime all solar heat is used for increasing the temperature to the evaporator or recharging of the borehole (operation mode 1) and in summer all solar heat is used in domestic hot water system (operation mode 2). The actual dates for changing the modes may be optimized for different systems and in the simulated cases this was found to be November to February for mode 1 and March to October for Mode 2.

6.4.6 All solar heat to a brine tank and to the heat pump/borehole – system 6

In system 6, the impact of a brine tank was studied, see Figure 6.11. The solar heat was delivered to a brine tank in order to maintain the incoming temperature, before using it in the heat pump.

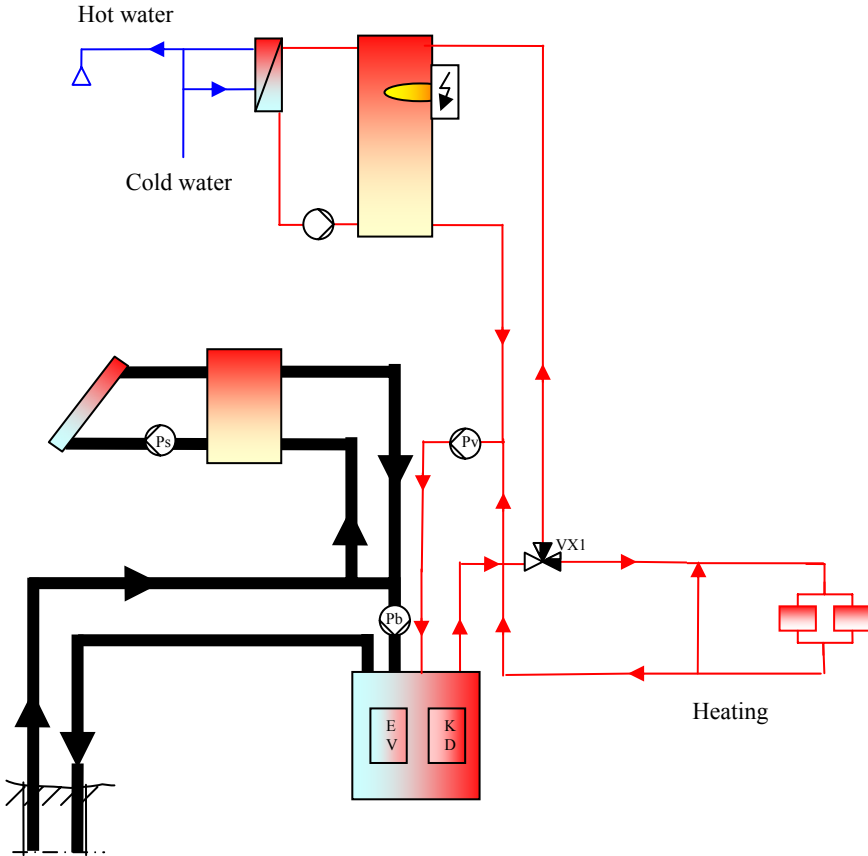

Figure 6.11 System 6 – all solar heat to a brine tank connected to the heat pump and the borehole.

7 Results of simulations

In this Chapter describes the results of the simulations. In the 7.1.1 there is an overview of the systems and 7.1.3 there is a table with an overview of the number of the figures with simulation results for different parameters.

7.1 Studied parameters

7.1.1 Overview of the systems

The main study was to compare a system without solar collectors with the most promising systems including solar heat, and investigate the savings in electricity for the different systems. Only single-family dwellings were simulated. Table 7.1 shows an overview of the systems.

Table 7.1 System overview.

1. No solar heat - Reference case – a conventional ground-source heat pump system.		
--	--	--

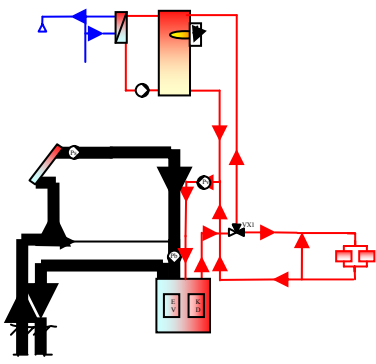
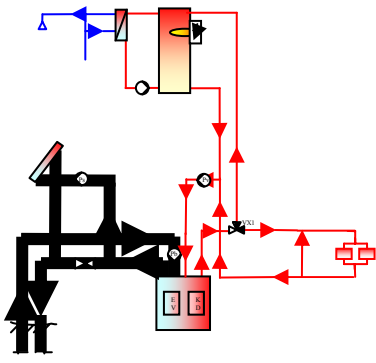
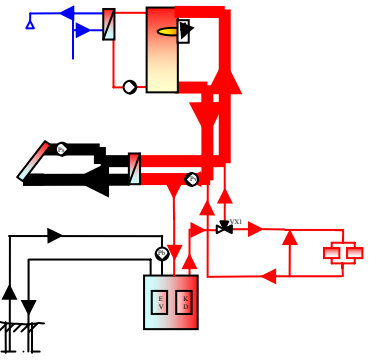
<p>2. Solar heat to the borehole passing the heat pump, increasing the temperature to the evaporator when the heat pump is in operation</p>		
<p>3. Solar heat direct to the borehole</p>		
<p>4. Solar heat to domestic hot water</p>		

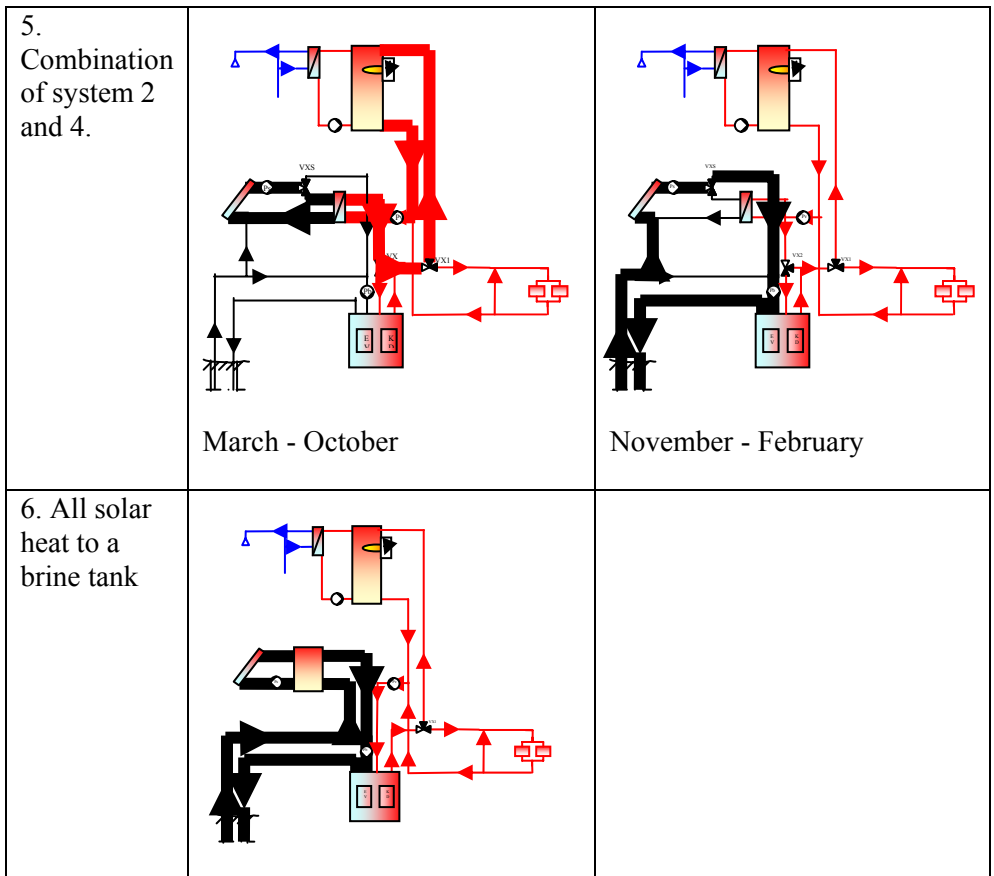

After the first simulations, the result indicated that system 3 and 6 was not promising in system efficiency, so major simulations were conducted with system 1 (as reference case), system 2, system 4 and system 5 (which is the combination between 2 and 4). All reported results are from simulations of system 1, 2, 4 and 5.

7.1.2 Overview of the parameters

The analysed outputs and parameters are:

1. Minimized use of electricity in the systems for different depth of boreholes, with acceptable minimum temperatures in the borehole
2. Analyse of temperatures to the evaporator

3. Coefficient of Performance (COP) for the heat pump in different systems
4. Use of electricity for all systems
5. Seasonal Performance Factor (SPF) for all systems
6. Savings of electricity with solar heat
7. Extracted heat from the borehole with different systems
8. Effect of special simulated recharging
9. Different thermal conductivity in the ground
10. Different thermal resistance in ground heat exchangers
11. Different area of solar collectors
12. Effect of numbers of years in the simulation
13. Result for climate in south of Sweden
14. Costs for the systems

The reference case 1, is a system without solar collectors. The bases cases that were analysed with a variation of depth of the boreholes, were the three systems with solar heat, varied with the heat pump size; 2 - Solar heat to the borehole passing the heat pump, increasing the temperature to the evaporator when the heat pump is in operation, 4 - Solar heat to domestic hot water and 5 - Combination of system 2 and 4, with solar heat to the domestic hot water during March – October and solar heat to the ground during November to February.

Input data used in the simulations for the reference cases and the simulated variations:

Climate: Stockholm, variation Malmö

Heating load, building: 26 000 kWh/year

Domestic hot water load: 3 400 kWh/year

Overall conductance of the building: 250 W/K

Building thermal capacitance: 10 GJ/K

Heat pump: 7 kW_{th}, variations 6 and 8 kW_{th}

Borehole depth: 60-160 m

Thermal conductivity in the ground: 3.5 W/m,K, variation 2.7 W/m,K,

Thermal resistance in ground heat exchangers: 0.1 K/(W/m), variations 0.03 and 0.07 K/(W/m)

Solar collectors: 10 m² flat plate, variations 5 and 15 m²

Result from year 20 of operation, variation 5 year

7.1.3 Overview of the figures with the simulation results

Table 7.2 is listing the figure numbers in Chapter 7, with the results of the simulations for different parameters and different systems.

Table 7.2 Overview of the number of the figures in Chapter 7 with presented results.

Analyse of	Results in figures
COP for the heat pump	Reference cases 7.4
Seasonal performance factor SPF for the systems	Reference cases 7.6-7.7
Temperatures to the evaporator	Reference cases 7.1-7.3
	During 20 years of operation, 100 m borehole 7.34-7.35
	Effect of recharging 7.18-7.20
	Thermal resistance in ground heat exchangers 7.29-7.31
Use of electricity	Reference cases 7.5
	Thermal conductivity in the ground 7.21-7.24
	Thermal resistance in ground heat exchangers 7.26-7.27
	Years of operation 7.36
	Climate 7.38-7.39
Savings of electricity	Reference cases 7.8-7.10
	Thermal conductivity in the ground 7.25
	Thermal resistance in ground heat exchangers 7.28

	Solar collector area	7.32-7.33
	Years of operation	7.37
	Climate	7.40
Extraction of heat from the borehole	Reference cases	7.11-7.15
	Effect of recharging	7.16-7.17
Costs	Reference cases	7.41-7.46

The overall question is the benefit of solar heat in the systems and the results are compared to a reference system without solar collectors. The advantage with solar heat can be described as reduced use of electricity in the system but also as the possibility of using shorter boreholes. If the system is undersized and the auxiliary electrical heater is used more than normal, the benefit of solar heat increases dramatically. Finally, solar heat can replace extracted heat from the ground in systems with neighbouring boreholes.

7.1.4 Minimized use of electricity

The electricity used in the system is calculated in the following way:

$$\sum Q_{el} = Q_{hp} + Q_{auxh} + Q_{auxs} + Q_{pb} + Q_{ps} \quad [\text{kWh}] \quad (5)$$

$\sum Q_{el}$ = Total use of electricity in the system (kWh)

Q_{hp} = Electricity used by the compressor in the heat pump (kWh)

Q_{auxh} = Electricity used by the auxiliary electrical heater in the heat pump (kWh)

Q_{auxs} = Electricity used by the auxiliary electrical heater in the storage tank (kWh)

Q_{pb} = Electricity used by the brine pump in the borehole system (kWh)

Q_{ps} = Electricity used by the circulation pump in the solar collector system
(kWh)

The electricity to the circulation pump in the heating distribution system in the building is not included in the analyses. This is regarded to be the same for all systems and of less importance to quantify.

In an ordinary and properly sized ground-source heat pump system for single-family dwellings, the heat pump covers 60-70% of the maximum house load for heating. This means that about 90% of the total, yearly heating demand, including domestic hot water, is covered by the heat pump. This means that in properly sized systems, the use of electricity in the compressor is the largest part and the use of auxiliary electricity is a minor part of the total use.

The use of electricity to the circulation pumps depend on type, size, system and operating time. In ground-source heat pump systems without solar collectors, the use of electricity to the circulation pump is proportional to the operating time of the heat pump and may be in the same order of size as the auxiliary heat. In systems with solar collectors, the use of electricity to the circulations pumps can be very high, if the operating time for the solar collectors is regulated to collect solar heat with a low temperature increase.

7.2 Temperature to the evaporator in different systems

In order to analyze the use of electricity, the systems were simulated with varying borehole depths between 60 - 160 m. The shortest boreholes are too short and clearly undersized. In order to analyze the behaviour in undersized systems, the energy-weighted, monthly mean temperature to the evaporator (when the heat pumps in is operation) was calculated. The simulation time was 20 years and the coldest month was in January, February or March depending on the system. In the systems with extreme undersized depth of boreholes, the coldest month was in December. The reason for this is that the auxiliary electrical heat is covering a major part of the energy demand in the coldest months (January and February) as the output of the heat pump is not sufficient.

When the temperature to the evaporator is below a critical temperature (predefined from the heat pump manufacturer and measured as a low pressure value), the heat pump shuts down and the auxiliary electrical heater takes over. The operating time and demand of auxiliary electricity depend on the size of power of the heat pump in correlation with the possibility of heat extraction from the borehole (varied by the depth of the borehole). With a larger heat pump installed in the system, less operating time for the heat pump and more

auxiliary electricity are needed for short boreholes. The lowest temperature for short boreholes is found in the system with the small heat pump compared to larger heat pump. On the other side the temperature is highest for deeper boreholes with the small heat pump, see Figure 7.1.

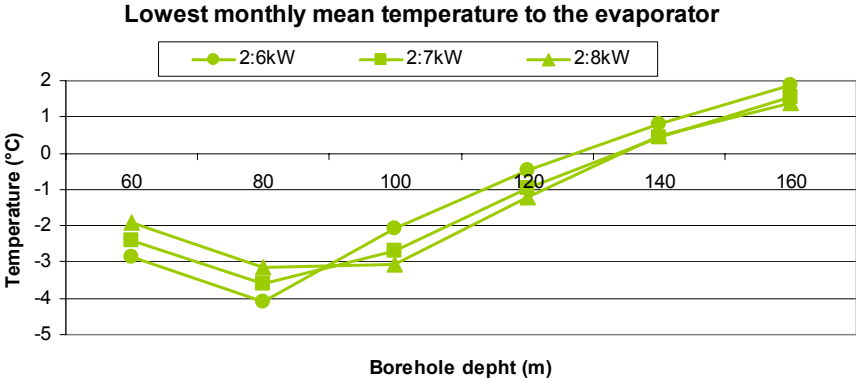

Figure 7.1 Lowest monthly mean temperatures to the evaporator with different depth of boreholes, for three sizes of heat pumps in system 2 – with all solar heat recharging of the borehole. Reference case: Stockholm climate, 10 m² flat plate solar collector, about 29 400 kWh/year heat and DHW demand, result from operation year 20.

When comparing lowest monthly mean temperature to the evaporator between the different simulated systems, the coldest temperatures was shown, as expected, in the system without solar energy, system 1, see Figure 7.2. In system 4, where all solar heat was used for domestic hot water, the temperatures were slightly higher, but almost similar. The advantage in increased temperature due to the difference in the natural recharging during the summer was about 0.15°C for the coldest month, February.

The highest temperature was found in system 2, but system 5 was very similar except for the shortest boreholes. In system 5, the solar heat was used for recharging during the coldest period, November – February, which was giving almost the same result in temperature increase for the coldest month (except for the shortest borehole) as if the recharging was going on the whole year.

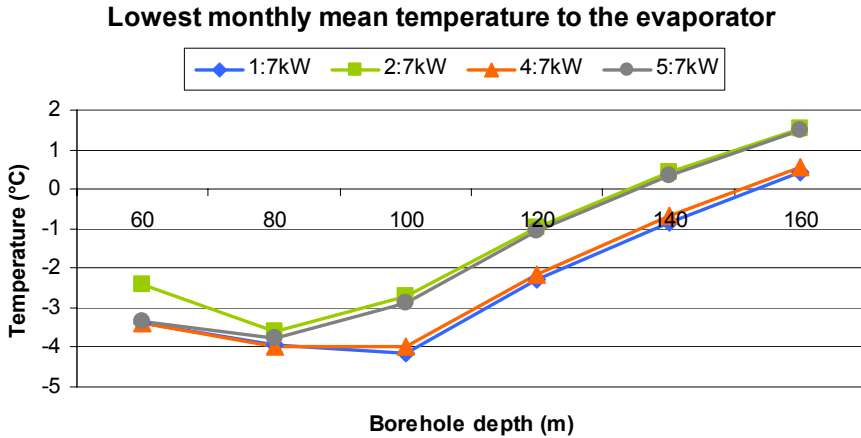

Figure 7.2 Lowest monthly mean temperatures to the evaporator with different depth of boreholes, for four different systems with heat pump 7 kW. Reference case: Stockholm climate, 10 m² flat plate solar collector, about 29 400 kWh/year heat and DHW demand, result from operation year 20.

The month with the coldest temperature to the evaporator is different between the systems, see Figure 7.3. In systems without solar heat it is normally in February, as this month normally is the coldest, which gives the highest heating demand. System 4, with no recharging with solar heat, follows the same pattern. In system 2, with all solar heat recharging the borehole, the temperature is lowest in January, but the temperature over the year is several degrees higher compared the other systems. In the mixed system 5, the coldest month is in this case March, as the recharging during November to February is keeping the temperature up. During the rest of the year it is similar in temperatures as system 4.

Monthly mean temperature to the evaporator for different systems, 100 m borehole (for the year 20)

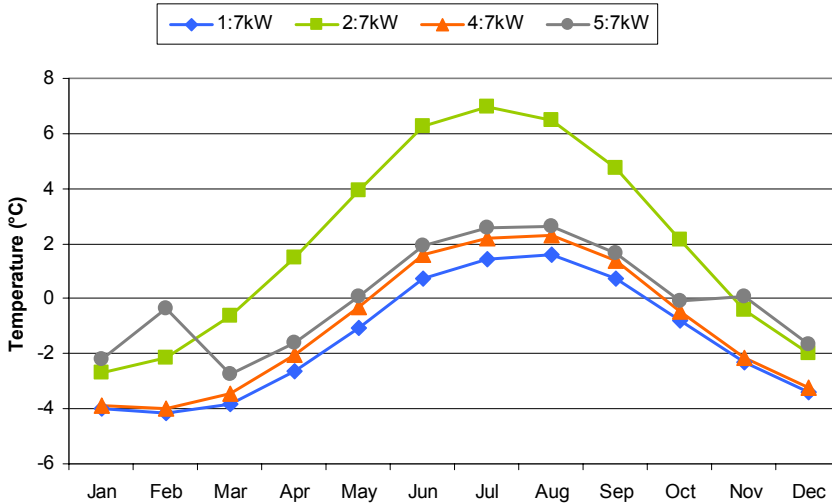

Figure 7.3 Monthly mean temperature to the evaporator for 100 m borehole, (heat pump power 7 kW) for four different systems. Reference case: Stockholm climate, 10 m² flat plate solar collector, about 29 400 kWh/year heat and DHW demand, result from operation year 20.

7.3 COP for the heat pump for a year

The coefficient of performance for the heat pump (COP) for the whole year depends on the whole system, as well as the operation and especially on the temperatures in the systems, the depth of the borehole and the power of the heat pump (in this case the load and the solar collector area are fixed). All systems show the same pattern with a minimum of the COP when the borehole gets too short for the heat pump. For shorter boreholes the COP increases when the auxiliary heater supplies energy to the system and the extraction from the boreholes decreases, see Figure 7.4.

For increasing depths of boreholes, the COP increases for all systems as the heat extraction/m in the borehole decreases and the temperatures in the systems increases.

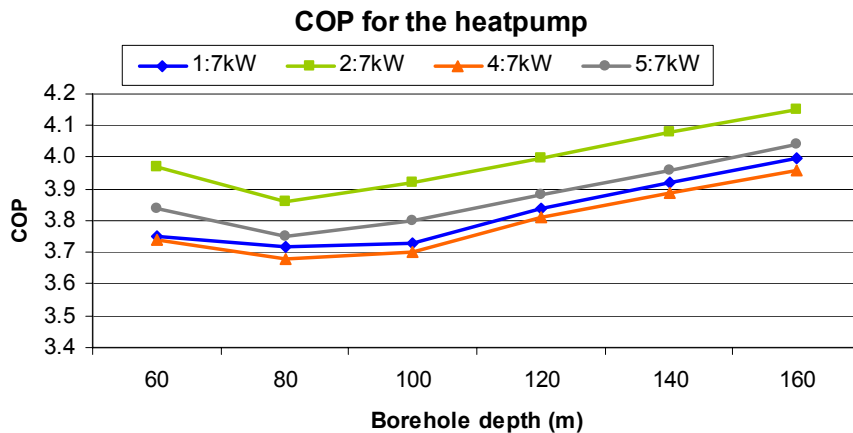

Figure 7.4 COP for the heat pump for four different systems for boreholes 60 – 160 m. Reference case: Stockholm climate, heat pump power 7 kW_{th} , 10 m^2 flat plate solar collector, about 29 400 kWh/year heat and DHW demand, result from operation year 20.

The difference between the systems, for varying depths of boreholes, shows an almost similar pattern compared to the differences in Figure 7.2, with the lowest monthly average temperatures to the evaporator. System 2, with all solar heat recharging the borehole, gives the best operational condition for the heat pump and also the highest COP. Although there is only recharging with solar heat to the borehole in four months during the winter, system 5 shows a higher COP compared to the other two systems.

7.4 Use of electricity

The use of electricity is calculated as the total sum of the electricity demand in the heat pump, the auxiliary electrical heaters for heating and domestic hot water, and the electricity to the brine and solar collector circulation pumps respectively.

The use of electricity increases rapidly for shorter boreholes, because of the increasing operating time for the electric auxiliary heater, see Figure 7.5. For the same load and solar collector area, the heat pump power also influences. A larger heat pump gives increased demand of auxiliary heat for short boreholes compared to a heat pump with less power. For smaller heat pumps the depth of

the borehole may be shorter, compared to larger heat pumps with the same use of electricity.

The load for the domestic hot water is in the reference case 3400 kWh/year and this is fulfilled in all systems. The load for the heating of the building is around 26 000 kWh/year and this is fulfilled in almost all systems, except for the systems with the shortest boreholes, 60 and 80 m respectively. This means that these systems were undersized and the temperature in the building was lower than the set point during the coldest hours. The lowest figure for the heating load was 23 400 kWh/year in the system without solar heat, with the borehole depth of 60 m. In this system, the operating time for the heat pump was decreased to less than half of the operating time compared with a properly dimensioned system. The actual behaviour in such a system depends on the regulation in the heat pump and the auxiliary heating system.

From about 100-120 m depth of boreholes and deeper, the use of electricity is only slightly decreasing for all systems and sizes of heat pumps. The differences between the systems are more discussed in Chapter 7.6, savings of electricity.

Use of electricity incl. circulation pumps, 6 kW heat pump

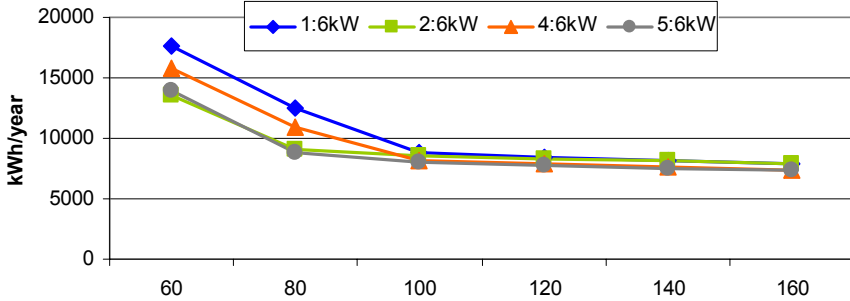

Use of electricity incl. circulation pumps, 7 kW heat pump

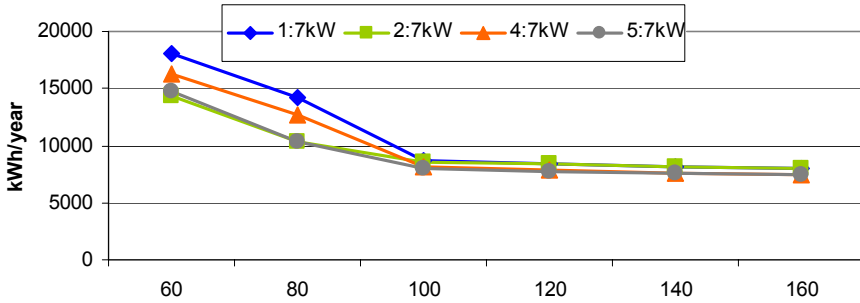

Use of electricity incl. circulation pumps, 8 kW heat pump

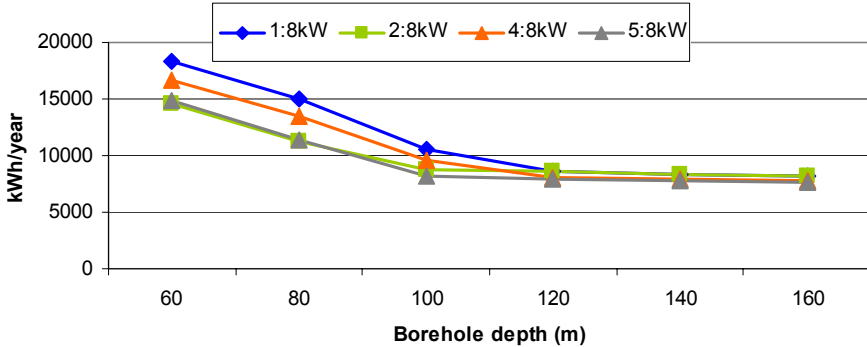

Figure 7.5 Use of electricity including circulation pumps for boreholes 60 – 160 m and heat pump power 6, 7 and 8 kW_{th} for four different systems. Reference case: Stockholm climate, 10 m² flat plate solar collector, about 29 400 kWh/year heat and DHW demand, result from operation year 20.

7.5 Seasonal Performance Factor (SPF) for the systems

The SPF for the system is defined as delivered heat from the heat pump divided by supplied electricity to the compressor, including electricity to the auxiliary heat and to the circulation pumps, over a year. SPF is sensitive to the depth of the borehole below a critical depth, see Figure 7.6. If the borehole is too short and the auxiliary electricity is used, the SPF decreases rapidly. For a properly designed system, the SPF increases slightly with deeper boreholes.

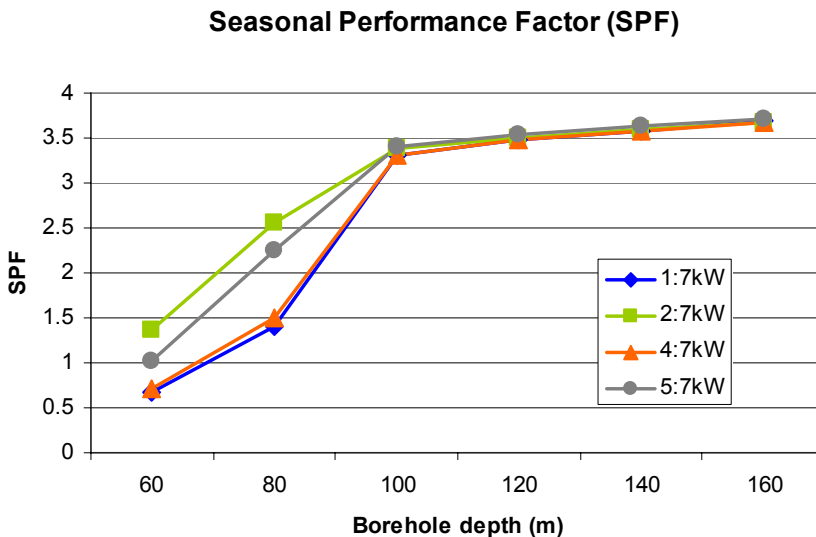

Figure 7.6 SPF for the system including auxiliary electricity and electricity to the circulation pumps for boreholes 60 – 160 m for four different systems. Reference case: Stockholm climate, heat pump power 7 kW_{th}, 10 m² flat plate solar collectors, about 29 400 kWh/year heat and DHW demand, result from operation year 20.

For different sizes of heat pumps, the smaller heat pumps give the highest SPF, but for the shortest boreholes, the heat load is not totally fulfilled during the coldest days. The heat load is 29 400 kWh/year, but in the systems with 60 m borehole, system 1 only delivers 26 100 kWh (heat pump 8 kW) up to 26 800 kWh (heat pump 6 kW) and for system 2 the corresponding delivered heat is 27 700 kWh (heat pump 8 kW) up to 28 000 kWh (heat pump 6 kW).

Comparing system 1 (without solar heat) and system 2 (charging borehole), system 2 has a higher SPF for boreholes shorter than 120 m, see Figure 7.7.

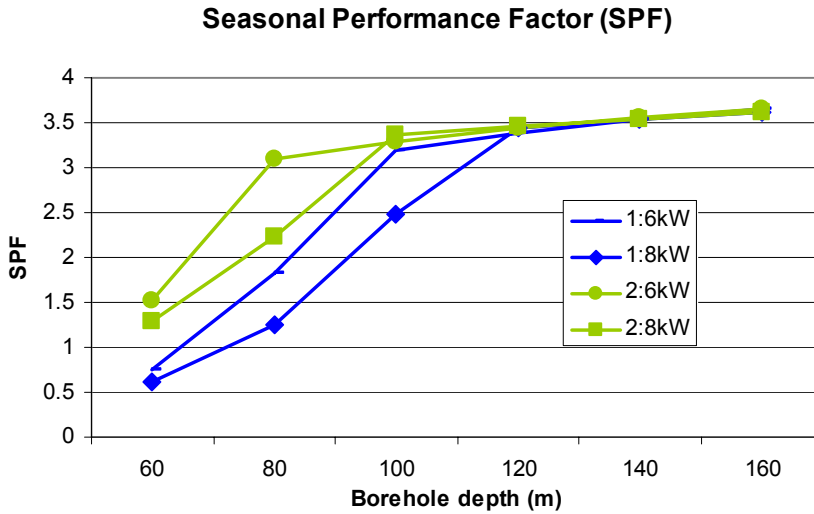

Figure 7.7 SPF for the system including auxiliary electricity and electricity to the circulation pumps for boreholes 60 – 160 m, for system 1 without solar heat and system 2 with recharging of the borehole with solar heat for the heat pump sizes 6 and 8 kW_{th}. Reference case: Stockholm climate, 10 m² flat plate solar collector, about 29 400 kWh/year heat and DHW demand, result from operation year 20.

7.6 Savings of electricity

The savings of electricity is defined as the difference in use of electricity between systems with and without solar heat respectively. When comparing different systems with and without solar heat, the savings of electricity gives comparable figures of the benefits of solar heat in the ground-source heat pumps systems.

In system 2, with all solar heat recharging of the borehole, savings of electricity for short boreholes is high, but there are no savings for deeper boreholes, Figure 7.8. Depending on the regulation and the demand of electricity to the brine pump, the need of electricity may exceed the savings in deeper boreholes. There is no advantage with recharging of the borehole, when the depth is enough for the natural recharging, but the advantage is large when the borehole is undersized.

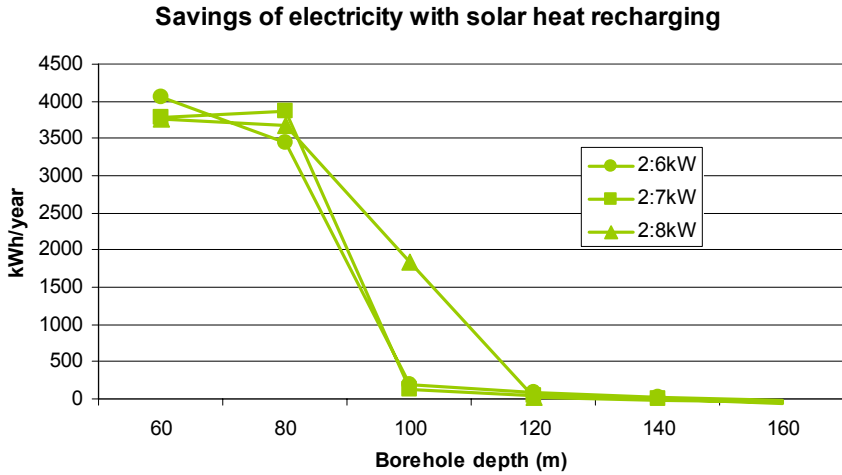

Figure 7.8 Savings of electricity with solar recharging in system 2 compared to system 1 without solar heat, for boreholes 60 – 160 m and for the heat pump sizes 6, 7 and 8 kW_{th} . Reference case: Stockholm climate, 10 m^2 flat plate solar collector, about 29 400 kWh/year heat and DHW demand, result from operation year 20.

For system 4, with all solar heat to the domestic hot water, the savings are less for the short boreholes compared to system 2, see Figure 7.9.

As solar heat is mainly replacing heat pump operation during summer time, the savings are at least 500 kWh/year for all depth of boreholes, and more for shorter boreholes, Figure 7.9.

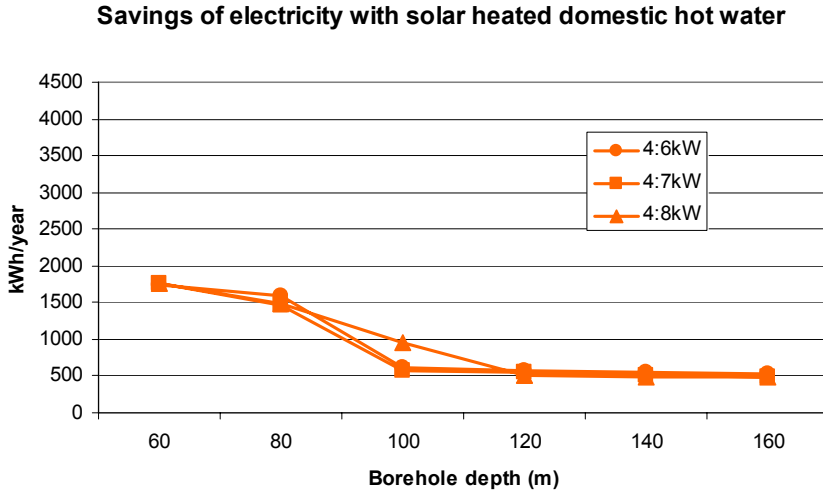

Figure 7.9 Savings of electricity with solar heated domestic hot water in system 4 compared to system 1 without solar heat, for boreholes 60 – 160 m and for the heat pump sizes 6, 7 and 8 kW_{th}. Reference case: Stockholm climate, 10 m² flat plate solar collector, about 29 400 kWh/year heat and DHW demand, result from operation year 20.

For the combined system 5, the savings of electricity is almost the same as for system 2 for the short boreholes and slightly higher than system 4 for the deeper boreholes, Figure 7.10.

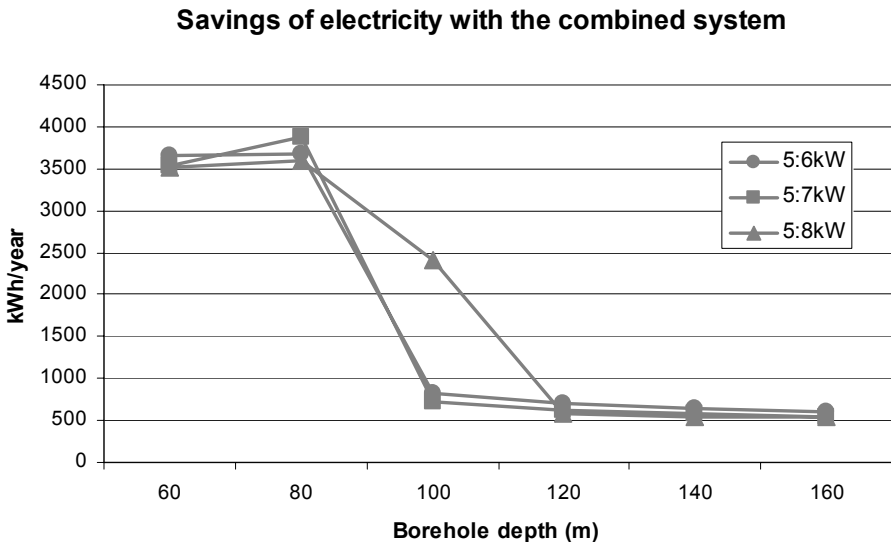

Figure 7.10 Savings of electricity in the combined system 5 with recharging in winter and solar heated domestic hot water in summer compared to system 1 without solar heat, for boreholes depths 60 – 160 m and for the heat pump sizes 6, 7 and 8 kW_{th}. Reference case: Stockholm climate, 10 m² flat plate solar collector, about 29 400 kWh/year heat and DHW demand, result from operation year 20.

Depending on the depth of the borehole, the savings with solar heat can be very different and may be discussed in three parts. For boreholes deeper than a system specific value, in this case 100 or 120 m depending on size of the heat pump, the savings with solar heat are relatively fixed within the different systems. In system 2, with all solar heat recharging of the borehole, there is almost no saving of electricity, while in system 4 and 5, the savings are mainly related to the demand of domestic hot water and is in the simulated systems in the order of 500-600 kWh/year.

For shorter boreholes the benefit of recharging of the boreholes increases rapidly to a specific depth, when the savings are not increasing and instead the temperature set point in the building is not fulfilled anymore. Too short boreholes give unbalanced systems and the result in savings is even more dependent of the interaction between the auxiliary heaters and the actual

heating demand. In the system with solar heat to the domestic hot water (4), the savings are also increasing with shorter boreholes, but only to a smaller part compared to systems with recharging. But in the combined system (5), the savings are the highest except for the shortest borehole (60 m), where the recharging gives higher savings in the simulated system.

7.7 Extraction of heat from the borehole

The net heat extracted from the borehole is defined as the extracted heat subtracted with the recharged solar heat. The net heat extracted from the borehole depends, except of the heating demand and the performance and size of the solar collector system, also on the size of the heat pump, the borehole depth and system. It is a large difference between the systems and when all solar heat is recharged (system 2), only about half of the heat is extracted during a year, compared to the system without solar heat, see Figure 7.11. This may be an important option in areas with thermal influence between adjacent boreholes.

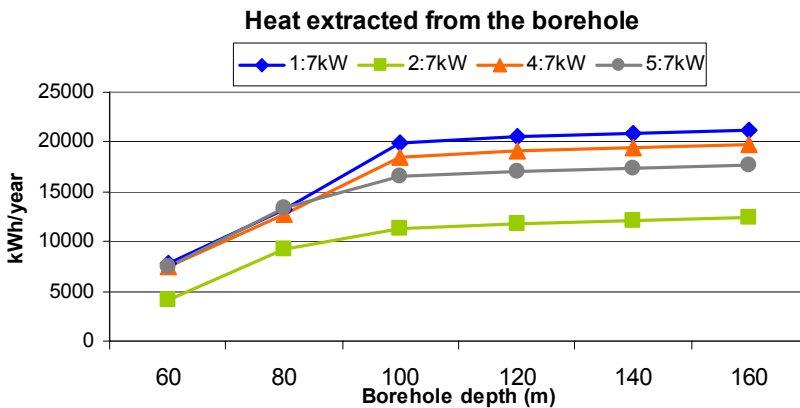

Figure 7.11 Heat extracted from the boreholes with the depths 60 – 160 m for four different systems. Reference case: Stockholm climate, heat pump power 7 kW_{th}, 10 m² flat plate solar collector, about 29 400 kWh/year heat and DHW demand, result from operation year 20.

The heat extracted per meter borehole shows a maximum for all systems but for different depths of borehole depending on system and heat pump power, Figure 7.12.

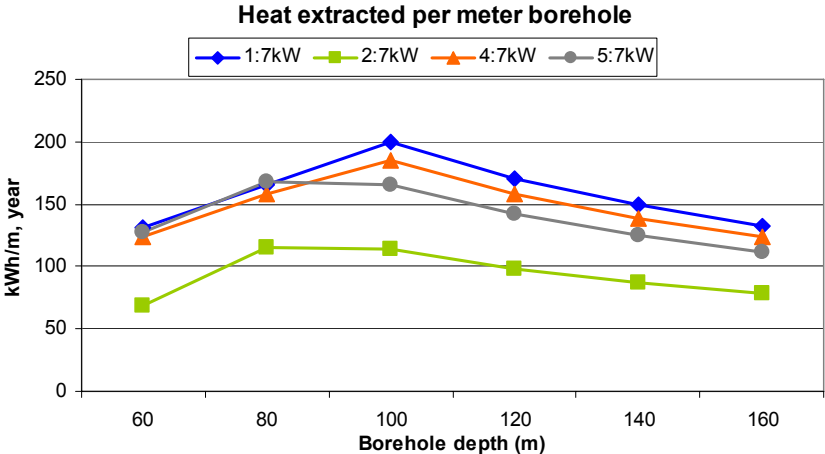

Figure 7.12 Heat extracted from the boreholes per meter with the depths 60 – 160 m for four different systems. Reference case: Stockholm climate, heat pump power 7 kW_{th}, 10 m² flat plate solar collector, about 29 400 kWh/year heat and DHW demand, result from operation year 20.

The power of the heat pump gives different result for shorter boreholes but almost no difference for deeper boreholes. For the system without solar heat, the maximum rate of heat extraction per meter borehole is 200 kWh/m, year for 100 m borehole, Figure 7.13. For deeper boreholes the rate of heat extraction decreases to less than 150 kWh/m, year.

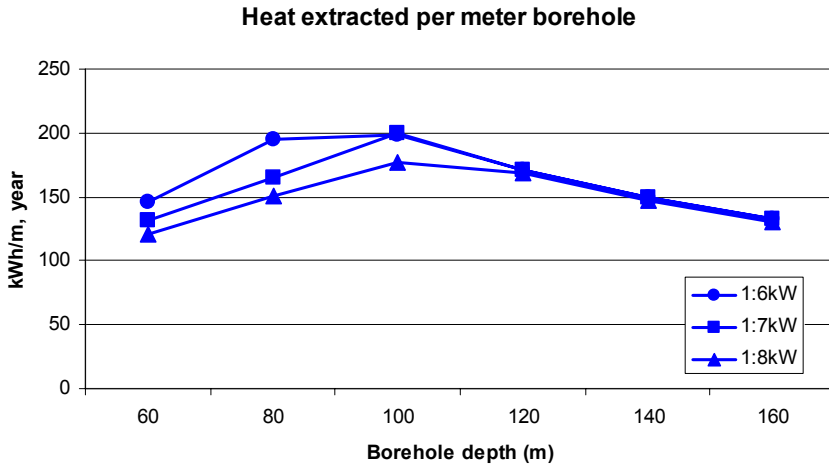

Figure 7.13 Heat extracted per meter from the boreholes with the depths 60 – 160 m for system 1 (without solar heat) and for the heat pump sizes 6, 7 and 8 kW_{th}. Reference case: Stockholm climate, about 29 400 kWh/year heat and DHW demand, result from operation year 20.

For the systems with solar heat, the same pattern is followed but with lower heat extraction rate and the maximum at 80 m borehole for the heat pumps with the power 6 and 7 kW, while the larger heat pump (8 kW) has a maximum at 100 m borehole, Figure 7.14. For deeper boreholes the heat extraction is almost the same for different heat pump power.

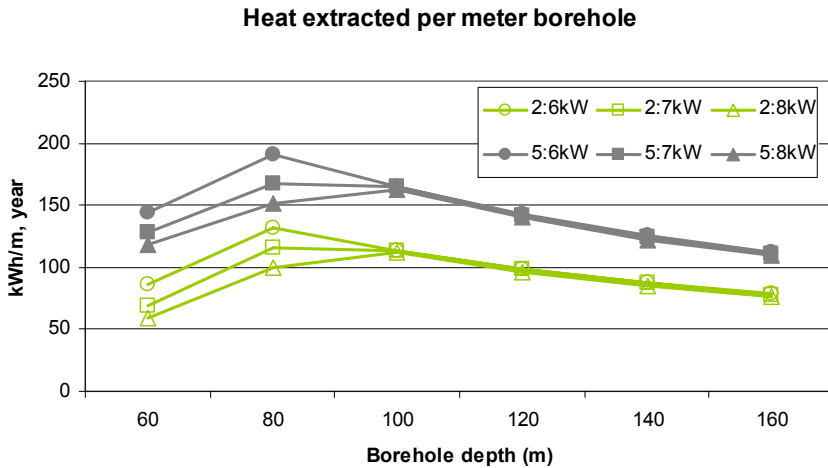

Figure 7.14 Heat extracted per meter from the boreholes with the depths 60 – 160 m for system 2 and 5 and for the heat pump sizes 6, 7 and 8 kW_{th}. Reference case: Stockholm climate, 10 m² flat plate solar collector, about 29 400 kWh/year heat and DHW demand, result from operation year 20.

The difference of extracted heat between the system without solar heat and the systems with solar heat is also describing the amount of heat recharged. The monthly variation over the year is shown in Figure 7.15, where the difference between system 1 and 2, shows the impact of the solar heat when all solar heat is recharged. During summertime the difference of heat extraction from the borehole is very large. In wintertime there is still less heat extracted from the borehole in system 2.

In system 4, with all solar heat to the domestic hot water, the difference of the extracted heat in a system without solar heat is less and there is almost no difference from November to the middle of February.

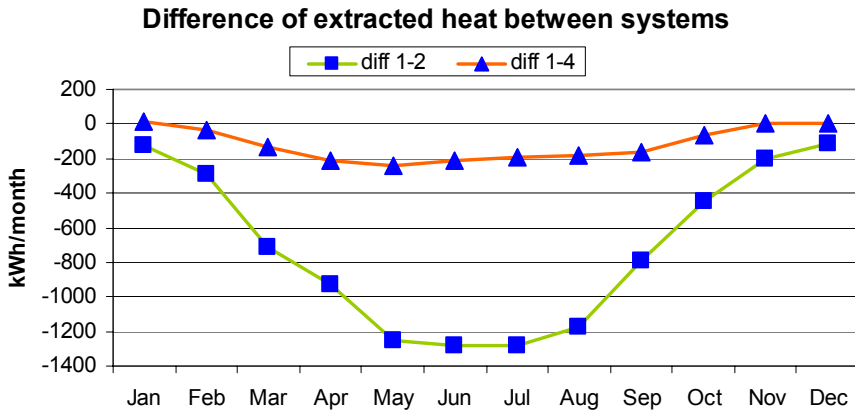

Figure 7.15 Difference of net heat extracted from the borehole between system 1 (without solar heat) and system 2 (all solar heat recharged), and system 1 and system 4 (all solar heat to the domestic hot water) respectively for a borehole with the depth 100 m and the power of the heat pump 7 kW_{th} . Reference case: Stockholm climate, 10 m^2 flat plate solar collector, about 29 400 kWh/year heat and DHW demand, result from operation year 20.

7.7.1 Study of the impact of special recharging

The impact of recharging of heat in the borehole is dependent of the energy flows in the system. Special simulations were conducted in order to study the performance in the system with different recharging power and schedules.

The performance in the system by recharging of heat during different times of the year shows that the best effect is achieved when the heat is used more or less simultaneously.

When recharging about 1000 kWh in February in system 1 (without solar heat) directly into the borehole, by using the brine pump when it is in operation for the heat pump, the result is that in the system with 100 m borehole and heat pump power of 7 kW, the extracted heat during February decreases with nearly the same amount that was recharged (830 kWh), see Figure 7.16. The power for the auxiliary heat for recharging was 1.7 kW.

Heat extracted from the borehole

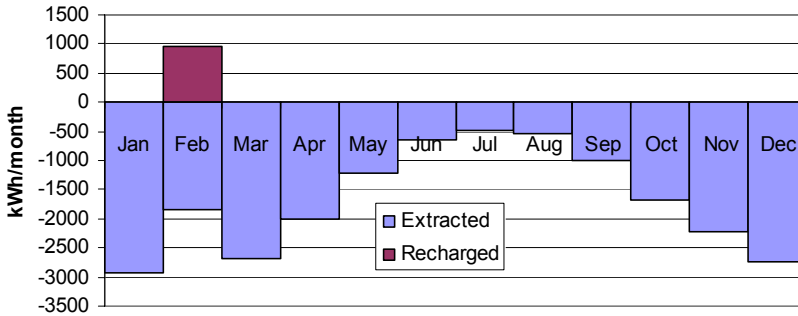

Figure 7.16 Heat extracted from the borehole in a simulation of system 1 (no solar heat) when heat is recharged just during February with an auxiliary heater (1.7kW) for a system with 100 m borehole and the power of heat pump 7kW_{th} . Reference case: Stockholm climate, about 29 400 kWh/year heat and DHW demand, result from the 3rd year of operation.

When testing the corresponding recharging for November a similar pattern is shown, see Figure 7.17. The same auxiliary power is recharged (1.7 kW) but as the operation time of the brine pump is less compared to February the recharged energy is about 800 kWh. The decrease in extracted energy is about 720 kWh during November.

Heat extracted from the borehole

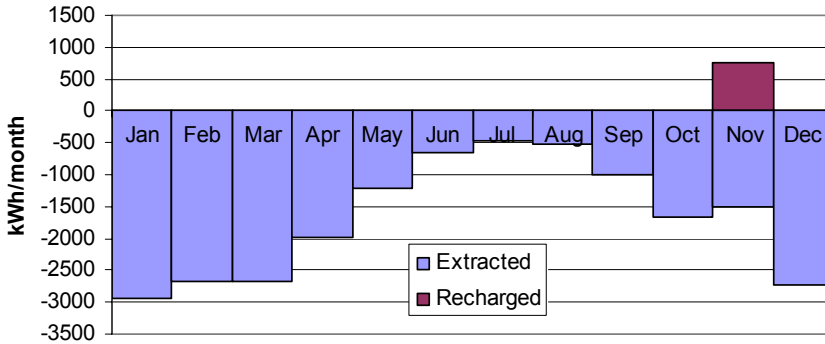

Figure 7.17 Heat extracted from the borehole in a simulation of system 1 (no solar heat) when heat is recharged just during November with an auxiliary heater (1.7kW) for a system with 100 m borehole and the power of heat pump $7kW_{th}$. Reference case: Stockholm climate, about 29 400 kWh/year heat and DHW demand, result from the 3rd year of operation.

The impact of recharging regarding the temperature in the borehole is similar, but depending on the energy flows in the system, there might be a remaining increased temperature also some months after the recharging. With a test of recharging 1400 kWh (17 kW) in July in system 1 (without solar heat) directly into the borehole, by using the brine pump when it is in operation for the heat pump, the result is that in the system with 100 m borehole and heat pump power of 7 kW, is the temperature in July almost 14°C (compared to about 2°C without recharging) and it is also a minor increase in the temperature during the following months, see Figure 7.18.

Temperature to the evaporator with recharging in July

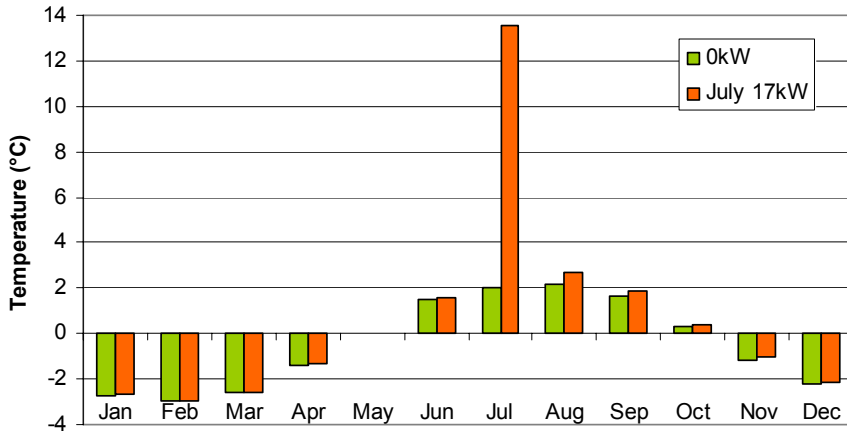

Figure 7.18 Monthly mean temperature to the evaporator in a simulation of system 1 (no solar heat) without recharging and when heat is recharged just during July with an auxiliary heater (17kW) for a system with 100 m borehole and the power of heat pump $7kW_{th}$. Reference case: Stockholm climate, about 29 400 kWh/year heat and DHW demand, result from the 3rd year of operation.

A test with recharging during July-September with 3400 kWh (10 kW), gives higher temperatures especially in October and a declining increase the following months, but even in June the following year, there is a minor impact on the temperature from the recharging, see Figure 7.19.

Temperature to the evaporator with recharging in July - September

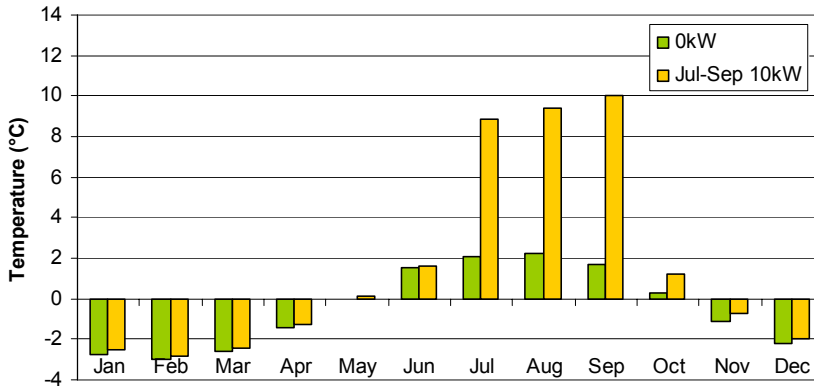

Figure 7.19 Monthly mean temperature to the evaporator in a simulation of system 1 (no solar heat) without recharging and when heat is recharged during July-September with an auxiliary heater (10kW) for a system with 100 m borehole and the power of heat pump $7kW_{th}$. Reference case: Stockholm climate, about 29 400 kWh/year heat and DHW demand, result from the 3rd year of operation.

In a shorter borehole, 80 m (with nothing else changed from the test above), the impact of the recharging is higher directly after the recharging but it is disappearing after a few months and there is no difference compared with a system without recharging after 3 months, see Figure 7.20.

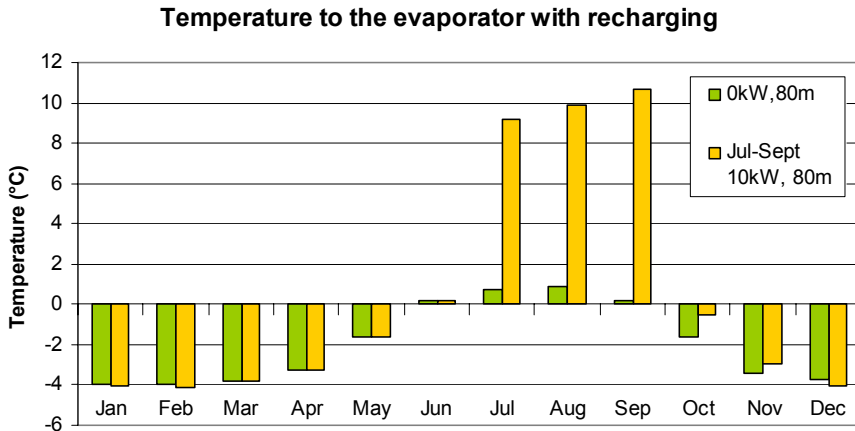

Figure 7.20 Monthly mean temperature to the evaporator in a simulation of system 1 (no solar heat) without recharging and when heat is recharged during July-September with an auxiliary heater (10kW) for a system with 80 m borehole and the power of heat pump $7kW_{th}$. Reference case: Stockholm climate, about 29 400 kWh/year heat and DHW demand, result from the 3rd year of operation.

The impact of the recharging depends on the proportion of the extracted heat, the depth of the borehole, the recharged heat and the timing for the energy flows in the system. Even if a large amount of heat is recharged in the borehole it gives a minor increase in the temperature to the evaporator, but this increase may be what is needed to stabilize a system where the temperature has become too low or is influencing another neighbouring system.

7.8 Thermal conductivity in the ground

The thermal conductivity in the ground influences the possibility of extracting heat. In the simulations presented above, the average value for Sweden, 3.5 W/m,K is used. If the thermal conductivity is lower, this is normally compensated with a deeper borehole. In Figure 7.21 the influence of the thermal conductivity is shown. The difference in electricity demand increases in systems with short boreholes, while there is only a small difference for boreholes deeper than (in this case) 120 m.

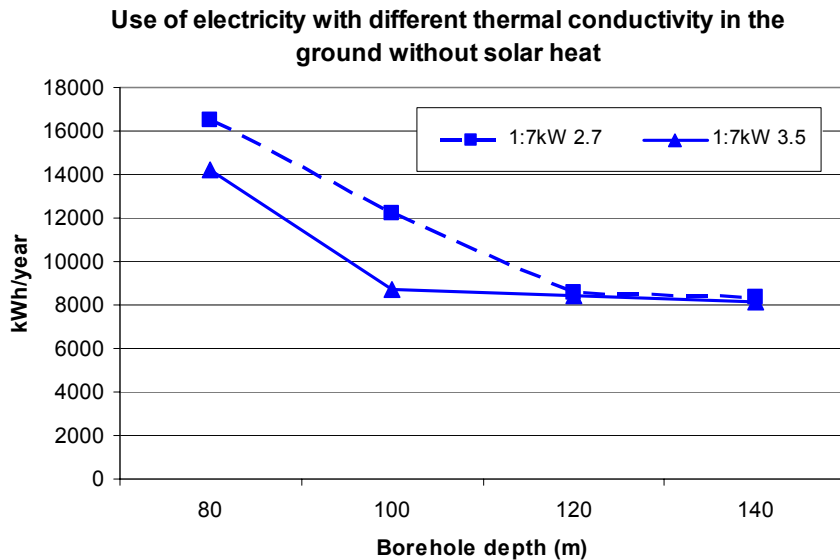

Figure 7.21 Use of electricity for two thermal conductivities in the ground, 2.7 and 3.5 W/m.K respectively in system 1 (without solar heat) with boreholes with the depths 80 – 140 m and the power of heat pump $7kW_{th}$. Reference case: Stockholm climate, about 29 400 kWh/year heat and DHW demand, result from operation year 20.

With solar recharging, the influence of the different thermal conductivities is decreased for the same depths of borehole, see Figure 7.22.

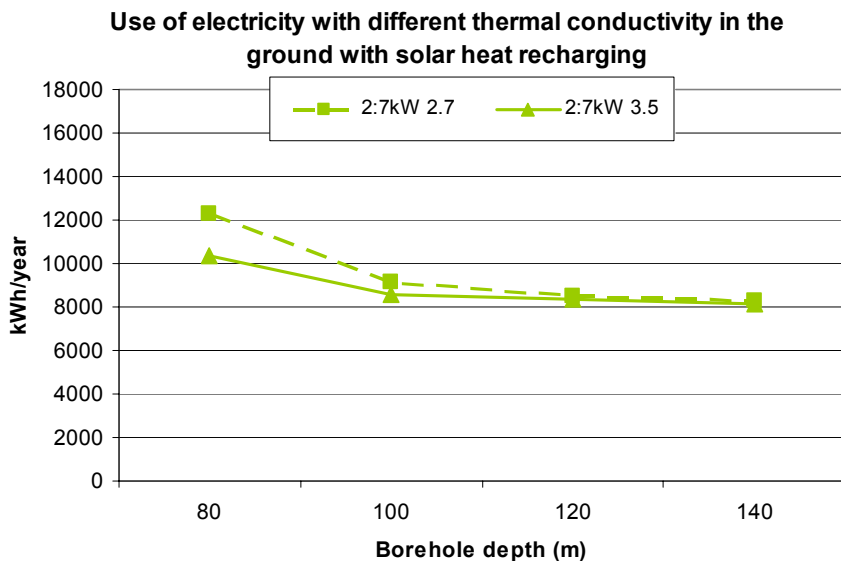

Figure 7.22 Use of electricity for two different thermal conductivity in the ground, 2.7 and 3.5 W/m,K respectively in system 2 (with all solar heat to the ground) with boreholes with the depths 80 – 140 m and the power of heat pump $7kW_{th}$. Reference case: Stockholm climate, 10 m^2 flat plate solar collector, about 29 400 kWh/year heat and DHW demand, result from operation year 20.

The combined system 5 (with recharging in winter and solar heated domestic hot water in summer) shows a similar pattern as system 2, see Figure 7.23.

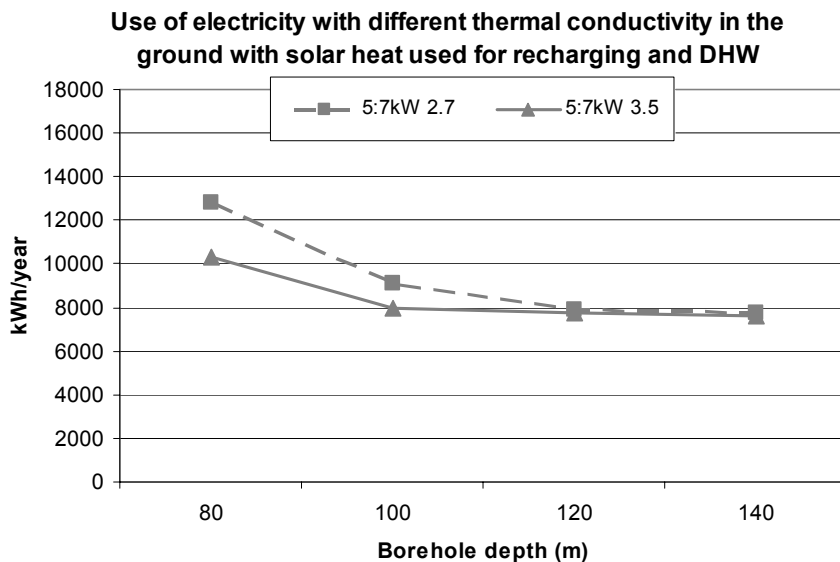

Figure 7.23 Use of electricity for two different thermal conductivities in the ground, 2.7 and 3.5 W/m,K respectively, in the combined system 5 with recharging in winter and solar heated domestic hot water in summer, with boreholes with the depths 80 – 140 m and the power of heat pump $7kW_{th}$. Reference case: Stockholm climate, 10 m^2 flat plate solar collector, about 29 400 kWh/year heat and DHW demand, result from operation year 20.

The use of electricity for the three systems; 1 (without solar heat), 2 (all solar heat to the ground) and 5 (with recharging in winter and solar heated domestic hot water in summer) is shown in Figure 7.24. Compared to Figure 7.5 (with thermal conductivity 3.5 W/m,K), there is a large difference for the borehole depth 100 m, regarding the influence of solar heat in the system.

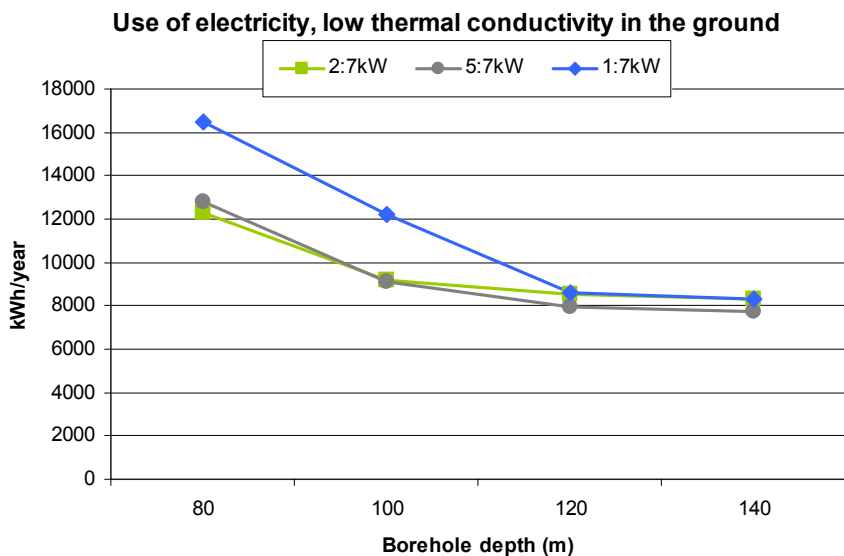

Figure 7.24 Use of electricity for low thermal conductivity in the ground, 2.7 W/m,K in system 1 (without solar heat), system 2 (all solar heat to the ground) and the combined system 5 (recharging in winter and solar heated domestic hot water in summer), for boreholes depths 80 – 140 m and the power of heat pump $7kW_{th}$. Reference case: Stockholm climate, 10 m^2 flat plate solar collector, about 29 400 kWh/year heat and DHW demand, result from operation year 20.

Figure 7.25 shows the savings of electricity with solar heat for system 2 (all solar heat to the ground) and combined system 5 (with recharging in winter and solar heated domestic hot water in summer). The influence of the different thermal conductivities 2.7 and 3.5 W/m,K respectively, is large for the short boreholes and small for the deep boreholes.

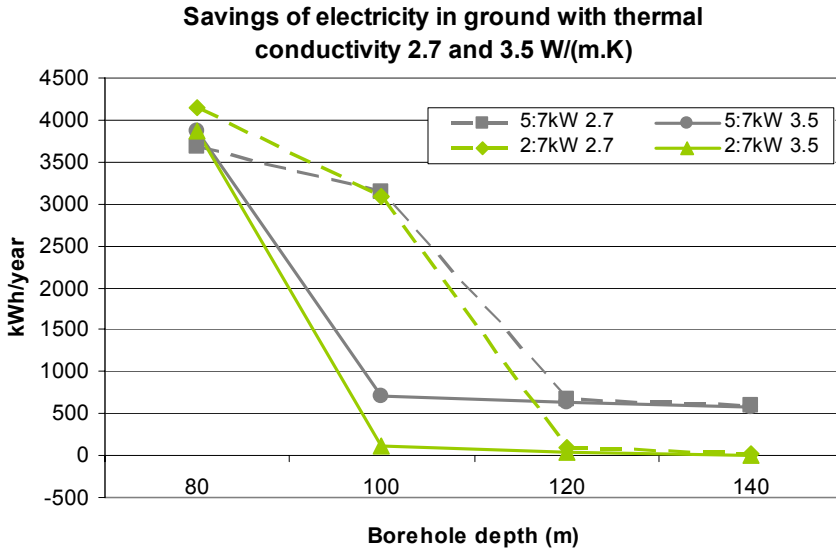

Figure 7.25 Savings of electricity for systems with solar heat compared to systems without solar heat for two thermal conductivities in the ground, 2.7 and 3.5 W/(m,K) respectively. System 2 (all solar heat to the ground) and the combined system 5 (recharging in winter and solar heated domestic hot water in summer), for boreholes depths 80 – 140 m and the power of heat pump 7 kW_{th}. Reference case: Stockholm climate, 10 m² flat plate solar collector, about 29 400 kWh/year heat and DHW demand, result from operation year 20.

7.9 Thermal resistance in ground heat exchangers

The thermal resistance in the borehole depends on the design of the ground heat exchanger. In the reference case a single U-pipe is used, as this is the most common type used in Sweden. The thermal resistance R_b , between the heat carrier fluid in the pipe and the borehole wall is normally 0.1 K/(W/m) for a single U-pipe. In order to analyse the influence of the different ground heat exchangers also a system with a double U-pipe and a C-pipe respectively are simulated. The thermal resistance of the double U-pipe is 0.07 K/(W/m) and for the C-pipe 0.03 K/(W/m). (The C-pipe is described in Chapter 4.)

In conventional ground source heat pump systems without solar heat (system 1), there is a large difference in use of electricity for short boreholes between systems with different thermal resistance in the ground heat exchanger. For properly designed systems, without an increased use of auxiliary electricity,

the difference in use of electricity is although small. In the simulated system, the difference between a system with a single U-pipe and a C-pipe may exceed 5000 kWh/year, compared to the total use for a C-pipe system which is about 8500 kWh/year, see Figure 7.26.

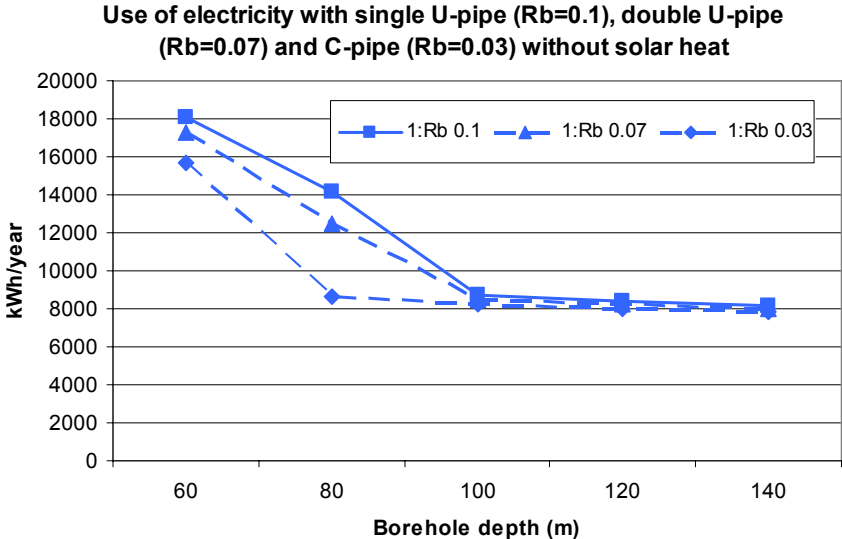

Figure 7.26 Use of electricity with single U-pipe ($R_b=0.1$ K/(W/m)), double U-pipe ($R_b=0.07$ K/(W/m)) and C-pipe ($R_b=0.03$ K/(W/m)) for system 1 (no solar heat) for borehole depths 60-140 m and the power of heat pump $7kW_{th}$. Reference case: Stockholm climate, about 29 400 kWh/year heat and DHW demand, result from operation year 20.

In systems with solar energy recharging of the borehole (system 2), the use of electricity is close to the systems without solar energy for properly sized systems. In systems with short boreholes the difference between the different types of ground heat exchangers are less, compared to systems without solar heat, see Figure 7.27.

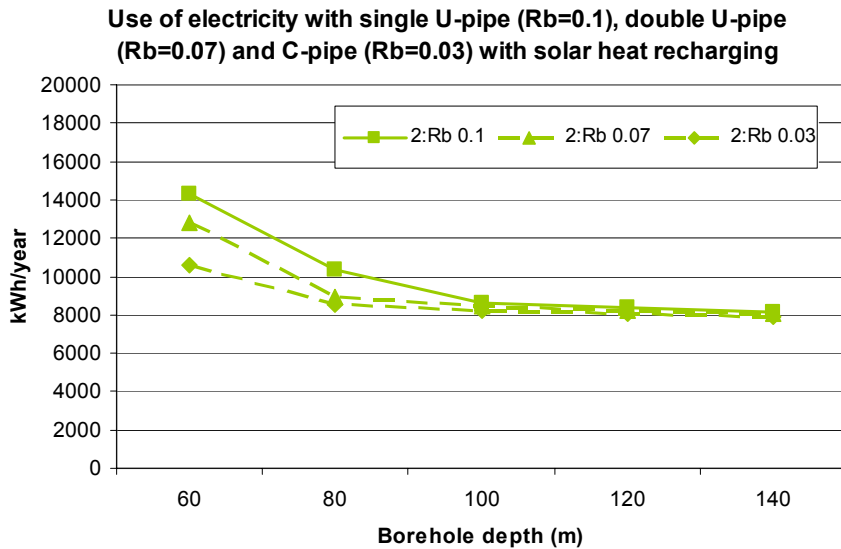

Figure 7.27 Use of electricity with single U-pipe ($R_b=0.1$ K/(W/m)), double U-pipe ($R_b=0.07$ K/(W/m)) and C-pipe ($R_b=0.03$ K/(W/m)) without solar heat for system 2 (all solar heat recharged to the borehole) for borehole depths 60-140 m and the power of heat pump $7kW_{th}$. Reference case: Stockholm climate, 10 m^2 flat plate solar collector, about 29 400 kWh/year heat and DHW demand, result from operation year 20.

When comparing the difference in savings between systems with solar heat recharging and without solar heat, there are minor savings in systems with improved thermal resistance in systems with sufficient depth of borehole, but the savings are large in undersized systems, see Figure 7.28.

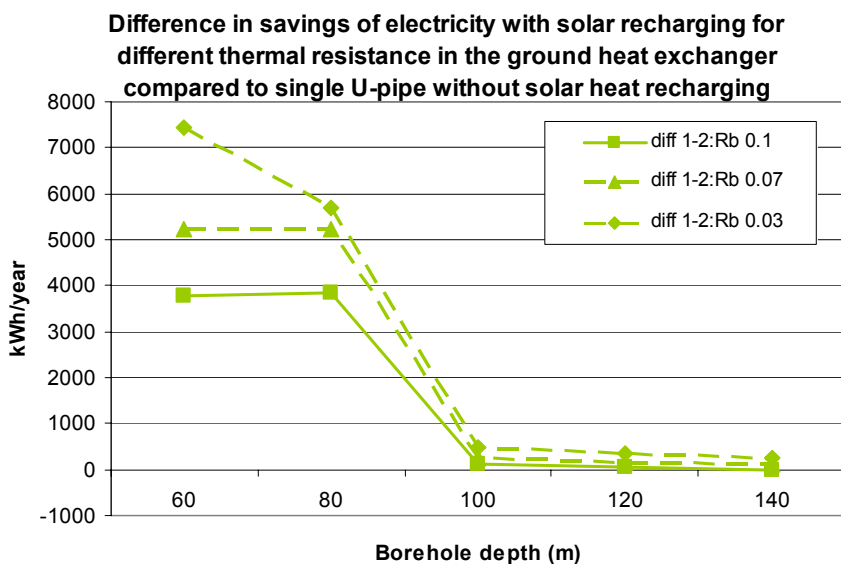

Figure 7.28 Difference of savings of electricity with solar recharging (system 2) for single U-pipe ($R_b=0.1$ K/(W/m)), double U-pipe ($R_b=0.07$ K/(W/m)) and C-pipe ($R_b=0.03$ K/(W/m)) compared to a single U-pipe without solar heat (system 1) for borehole depths 60-140 m and the power of heat pump $7kW_{th}$. Reference case: Stockholm climate, 10 m^2 flat plate solar collector, about 29 400 kWh/year heat and DHW demand, result from operation year 20.

Decreased thermal resistances in the ground heat exchangers gives increased lowest monthly mean temperature to the evaporator, except for very short boreholes, see Figure 7.29.

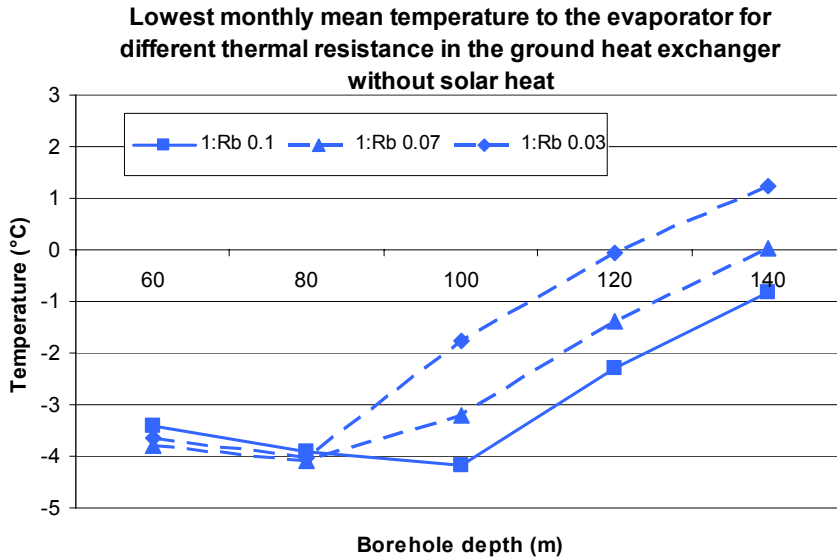

Figure 7.29 Lowest monthly mean temperature to the evaporator with single U-pipe ($R_b=0.1$ K/(W/m)), double U-pipe ($R_b=0.07$ K/(W/m)) and C-pipe ($R_b=0.03$ K/(W/m)) for system 1 (no solar heat) for borehole depths 60-140 m and the power of heat pump $7kW_{th}$. Reference case: Stockholm climate, about 29 400 kWh/year heat and DHW demand, result from operation year 20.

In the simulated systems without solar heat (system 1) the maximum difference of temperature (at 100 m depth of borehole) is about $2.4^{\circ}C$ for $R_b=0.07$ (C-pipe) compared to single U-pipe, decreasing slightly for deeper boreholes and with almost no difference for shorter boreholes. The minimum depends on the regulation of the auxiliary electricity and the shut off of the heat pump when the temperature is too low. For deeper boreholes the thermal performance is improved in the ground heat exchangers with decreased thermal resistance.

When solar heat is recharged in the systems, the lowest monthly mean temperature is increased and the minimum point is determined for shorter boreholes compared to without solar heat, Figure 7.30.

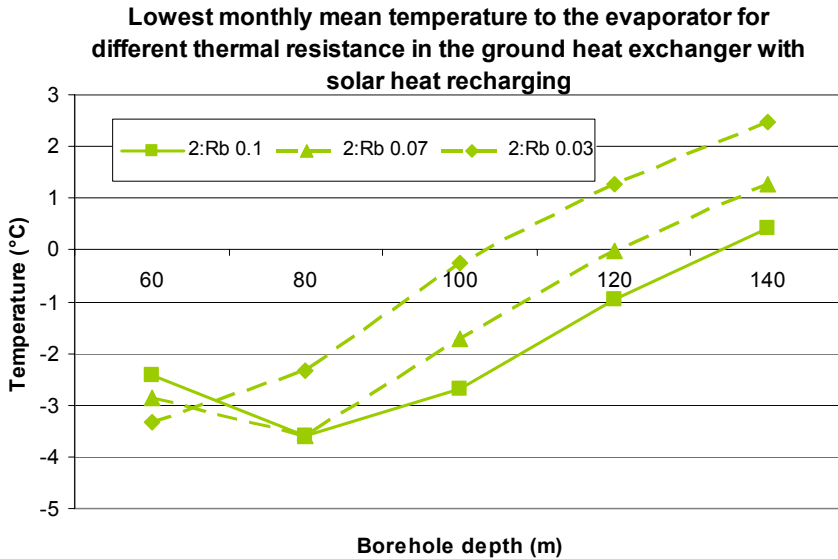

Figure 7.30 Lowest monthly mean temperature to the evaporator with single U-pipe ($R_b=0.1 \text{ K/(W/m)}$), double U-pipe ($R_b=0.07 \text{ K/(W/m)}$) and C-pipe ($R_b=0.03 \text{ K/(W/m)}$) for system 2 (all solar heat recharged to the borehole) for borehole depths 60-140 m and the power of heat pump 7 kW_{th} . Reference case: Stockholm climate, 10 m^2 flat plate solar collector, about 29 400 kWh/year heat and DHW demand, result from operation year 20.

The difference in depth of boreholes for e.g. the temperature -1°C is more than 25 m between the single U-pipe and the C-pipe and about 10 m between the single U-pipe and the double U-pipe.

When comparing the differences in the lowest monthly mean temperatures, between systems with solar heat and different thermal resistance in the ground heat exchangers, and the single U-pipe without solar heat, there is a maximum for the simulated systems at the depth 100 m. It is 4°C for the C-pipe and 2.5°C for the double U-pipe, see Figure 7.31.

Difference between lowest monthly mean temperature to the evaporator with solar recharging for different thermal resistance in the ground heat exchanger compared to single U-pipe without solar heat recharging

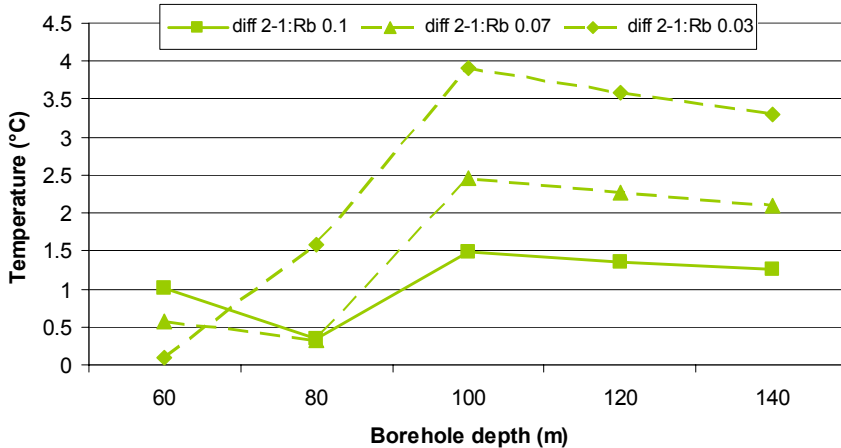

Figure 7.31 Difference between lowest monthly mean temperature to the evaporator with solar heat recharging (system 2) for single U-pipe ($R_b=0.1$ K/(W/m)), double U-pipe ($R_b=0.07$ K/(W/m)) and C-pipe ($R_b=0.03$ K/(W/m)) compared to a single U-pipe without solar heat (system 1) for borehole depths 60-140 m and the power of heat pump $7kW_{th}$. Reference case: Stockholm climate, 10 m^2 flat plate solar collector, about 29 400 kWh/year heat and DHW demand, result from operation year 20.

Although the difference in temperature is large for 100 m boreholes, the difference in savings of electricity is mainly achieved in shorter boreholes. The major explanation is that until a critical depth of the borehole, the ground heat is sufficient for the heat pump and the savings of electricity is moderate, but as soon as the auxiliary heat starts, the savings are large with thermal improvements in the system.

7.10 Area of the solar collectors

Increasing the solar collector area gives increased savings in use of electricity, although the amount may be limited, depending on the system. The savings are larger for shorter boreholes.

The area of the solar collectors was varied between 0, 5, 10 and 15 m^2 for system 2 (all solar heat to the ground) and system 5 (recharging in winter and

solar heated domestic hot water in summer). In system 2, no other parameters were changed, but in system 5 also the size of the hot water storage as well as the flow in the solar collector circuit were changed, see Table 7.3. In system 2 the circuits in the borehole and the solar collectors were linked together without a heat exchanger and that is the reason for the high flow in the solar collectors. Simulations with an extra heat exchanger and varying flow in the solar circuit showed increased gain in solar heat with decreased flow, but almost no changing in use of electricity.

Table 7.3 Parameters used in the simulations with different solar collector area.

System and solar collector area (m²)	1- No solar collectors	2 - All solar to ground, 5, 10, 15 m²	5 – Solar recharging winter/solar DWH summer, 5 m²	5 – Solar recharging winter/solar DWH summer, 10 m²	5 – Solar recharging winter/solar DWH summer, 15 m²
DHW storage tank volume (m ³)	0.3	0.3	0.5	1.0	1.5
Solar circuit flow rate (kg/h)	0	1620	300	600	900

For system 2 (all heat to the ground), the savings of electricity compared to a system without solar collectors, are large for short boreholes, see Figure 7.32. There is also a large difference between the three different solar collector areas, with e.g. in this case a 80 m deep borehole. When the depth of the borehole is increasing, the difference in savings of electricity between the three solar collector areas is decreasing. For the system with 5 m², there is in this case a negative result. The specific figure is also dependent on the pump regulation and pump efficiency and with an increased efficiency in the circulation pump, this may be positive instead, as well as it can be negative also for the other solar collector areas.

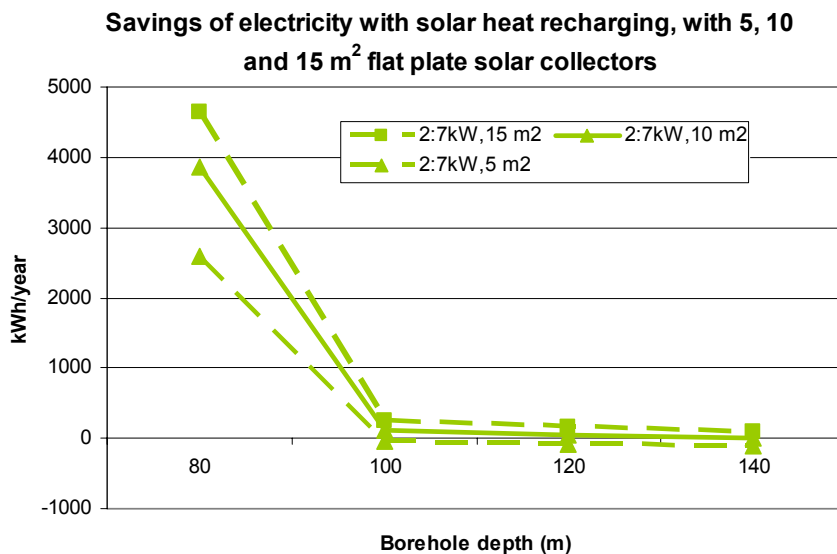

Figure 7.32 Savings of electricity for three different areas of solar collector (5, 10 and 15 m² flat plate solar collector respectively) in system 2 (all solar heat to the ground) compared to a system without solar collectors for borehole depths 80-140 m and the power of heat pump 7kW_{th}. Reference case: Stockholm climate, about 29 400 kWh/year heat and DHW demand, result from operation year 20.

For the savings of electricity in system 5 (with all solar heat to the ground in the winter and to the domestic hot water in the summer) is the influence of the solar collector area larger than in system 2, see Figure 7.33. The demand of heat during summer is of course important for the advantage of larger areas, as more heat during summer only may cause higher temperatures in the storage tank and also higher losses and decreased efficiency of the solar collector system.

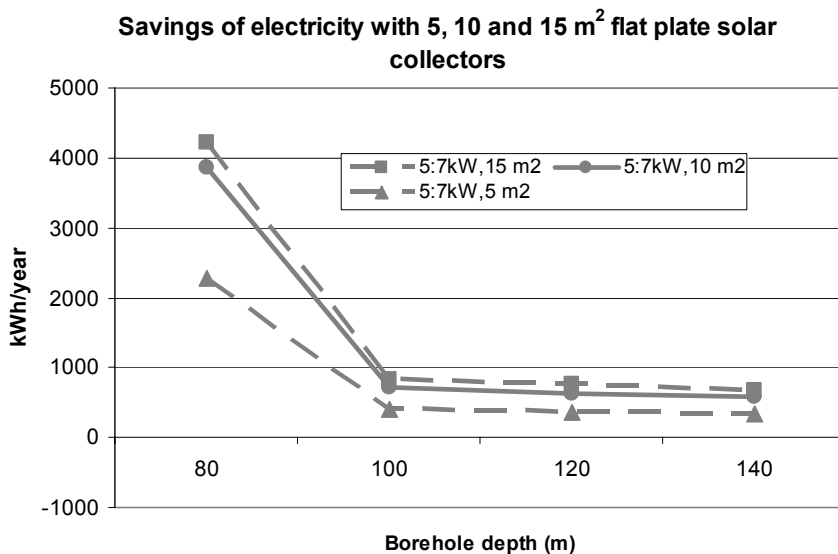

Figure 7.33 Savings of electricity for three different areas of solar collector (5, 10 and 15 m² flat plate solar collector respectively) in system 5 (recharging in winter and solar heated domestic hot water in summer) compared to a system without solar collectors for borehole depths 80-140 m and the power of the heat pump 7kW_{th}. Reference case: Stockholm climate, about 29 400 kWh/year heat and DHW demand, result from operation year 20.

7.11 Years of operation

In a ground-source heat pump system, the operational conditions may change over an operation period, depending on the energy flows in the ground. The major changes is normally taking place during the first 2-3 years, but if there is a large heat extraction from the ground, the differences may be significant during a longer time.

When comparing the lowest monthly mean temperature to the evaporator during 20 years of operation time, the large decrease is during the first year and followed by the next 2 years, see Figure 7.34. After 5 years the decrease is less and during year 5-20 the decrease is about 0.40°C for system 1 and 4. For system 2 the decrease is less, 0.23°C. Comparing between the systems the difference between system 1 and 4 is around 0.17°C during the operation time and the difference between system 2 and 1 is increasing from 1.32°C year 5 to 1.48°C year 20. During the year 15-20 the decrease is 0.013°C/year for system 1 and 4 but only 0.008°C/year for system 2.

Lowest monthly mean temperature to the evaporator

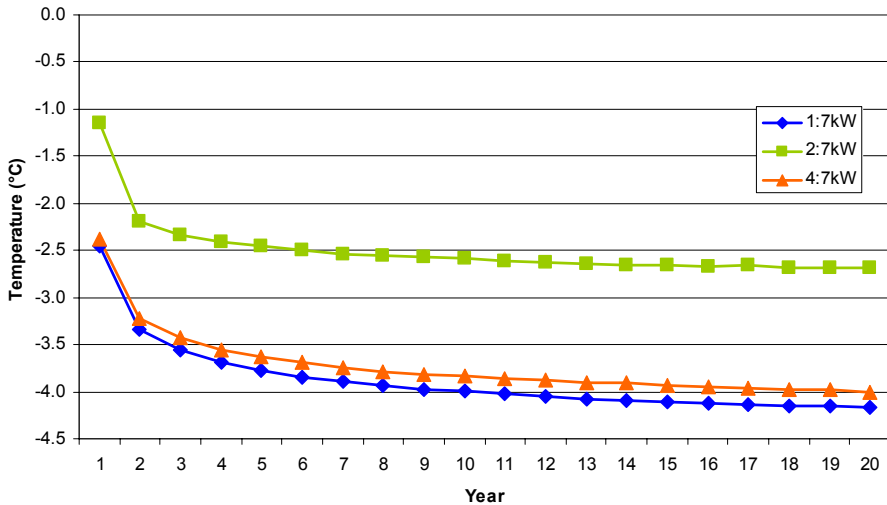

Figure 7.34 Lowest monthly mean temperature to the evaporator for system 1 (no solar heat), 2 (all solar heat recharged to the borehole) and 4 (all solar heat to domestic hot water) for a borehole with the depth 100 m and the power of the heat pump 7 kW_{th} during 20 years of operation. Reference case: Stockholm climate, 10 m^2 flat plate solar collector, about 29 400 kWh/year heat and DHW demand.

The variation of the temperature to the evaporator during 20 years operation time is shown in Figure 7.35 for system 1 (without solar heat), system 2 (all solar heat to the ground) and system 4 (all solar heat to the domestic hot water). During summertime the difference is large between system 2 and the others.

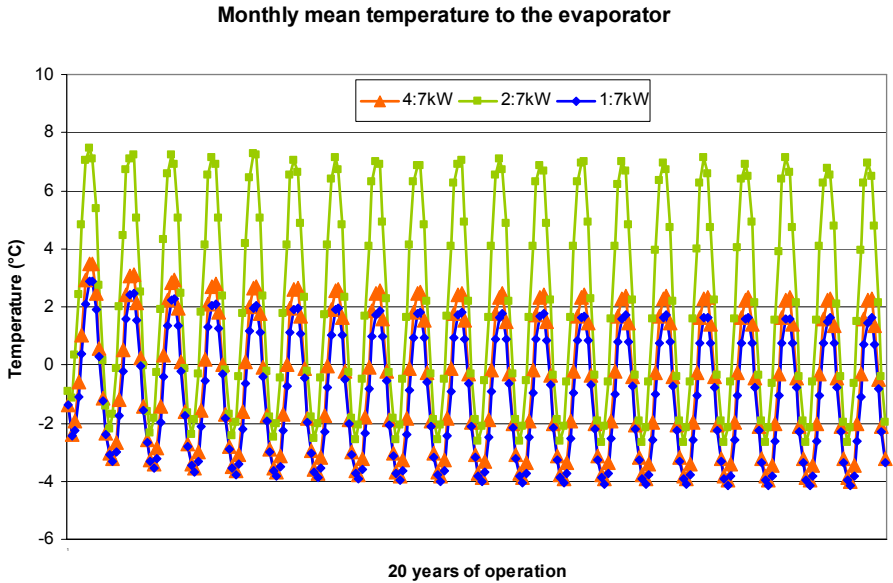

Figure 7.35 Variation of the monthly mean temperature to the evaporator for system 1 (no solar heat), 2 (all solar heat recharged to the borehole) and 4 (all solar heat to domestic hot water) for a borehole with the depth 100 m and the power of the heat pump 7 kW_{th} during 20 years of operation. Reference case: Stockholm climate, 10 m^2 flat plate solar collector, about 29 400 kWh/year heat and DHW demand.

Figure 7.36 shows the electricity demand for the 5th and the 20th year of operation for the system without solar heat and the system with all solar heat to the borehole (over the heat pump). For the system recharging solar heat there is almost no difference between the two years, but in the system extracting more heat from the ground, there is a difference for shorter boreholes (in undersized systems). The difference in use of electricity in properly sized systems between year 20 and year 5, are less than 0.5% with solar recharging and about 1% in systems without solar heat.

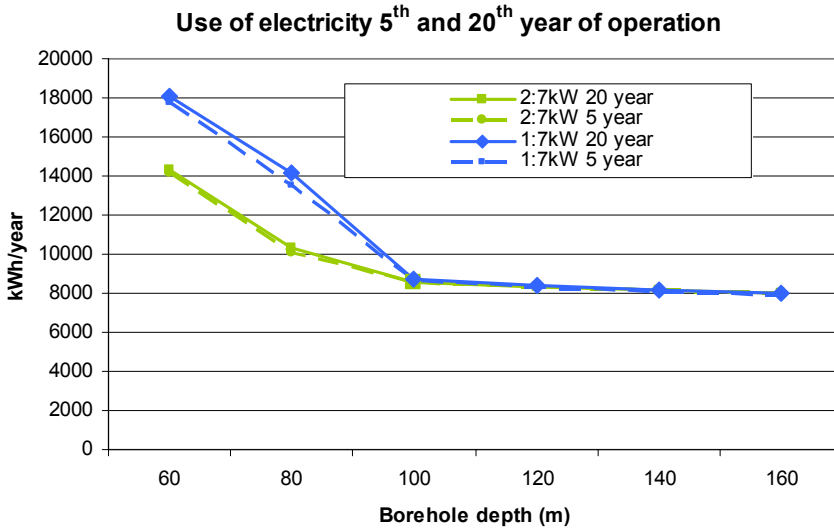

Figure 7.36 Use of electricity after 5 and 20 years of operation in system 1 (without solar heat) and system 2 (with all solar heat to the ground) for borehole depths 60-160 m and the power of heat pump 7 kW_{th}. Reference case: Stockholm climate, 10 m² flat plate solar collector, about 29 400 kWh/year heat and DHW demand.

The saving of electricity in system 2 with solar heat compared to system 1 without solar heat is shown for the 5th and the 20th year of operation in Figure 7.37. The difference between the years is high for short boreholes and almost negligible, even negative for deep boreholes.

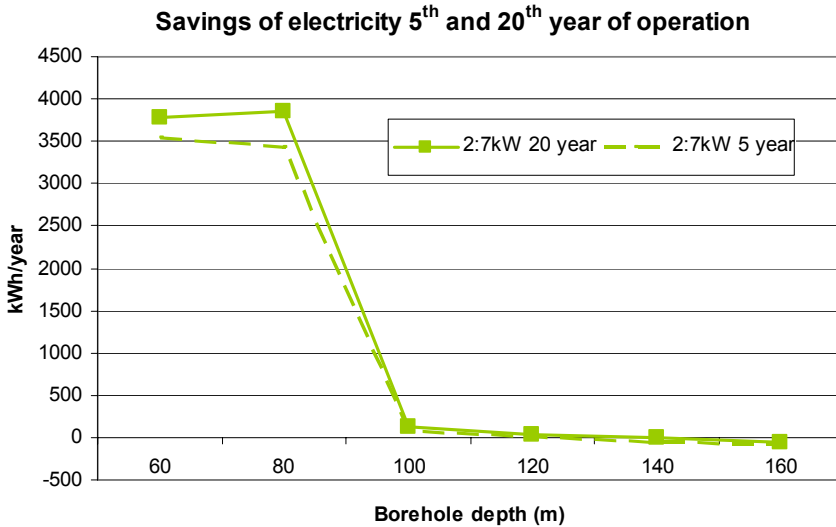

Figure 7.37 Savings of electricity after 5 and 20 years of operation with system 2 (with all solar heat to the ground) compared to system 1 (without solar heat) and the power of heat pump $7kW_{th}$. Reference case: Stockholm climate, 10 m^2 flat plate solar collector, about 29 400 kWh/year heat and DHW demand.

7.12 Climate in the south of Sweden

The influence of the climate is studied by simulation of the systems in Malmö in the south of Sweden. Malmö has a milder climate compared to Stockholm. In order to be able to compare the influence of the climate, all parameters except of the weather file have been kept the same as the simulations for the Stockholm climate. The energy demand (for the same building) decreases from 29 400 kWh/year in Stockholm to 26 600 kWh/year (incl. domestic hot water) in Malmö.

Figures 7.38 and 7.39 show the use of electricity for systems without solar heat (1) and with all solar heat recharged to the ground (2) for the climate in Stockholm and Malmö respectively. For shorter boreholes the difference in use of electricity increases.

Use of electricity, Malmö and Stockholm 5th year

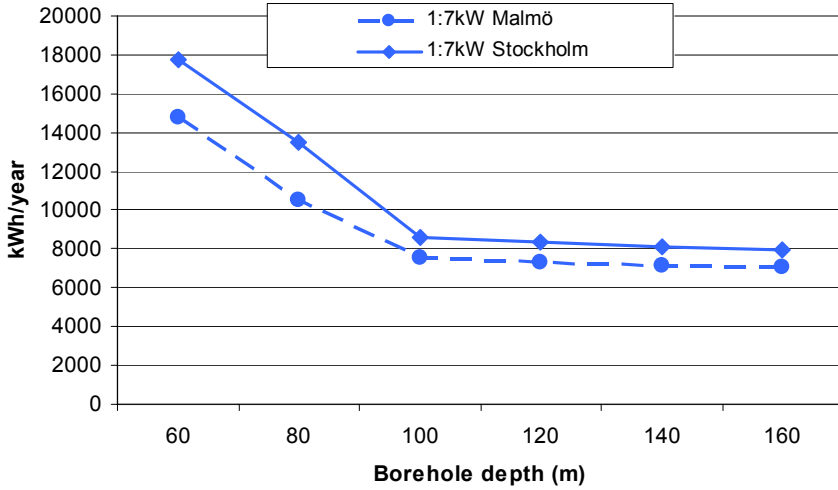

Figure 7.38 Use of electricity in system 1 (without solar heat) in Malmö and Stockholm respectively for borehole depths 60-160 m and the power of heat pump $7kW_{th}$. 5 years of operation.

Use of electricity, Malmö and Stockholm 5th year

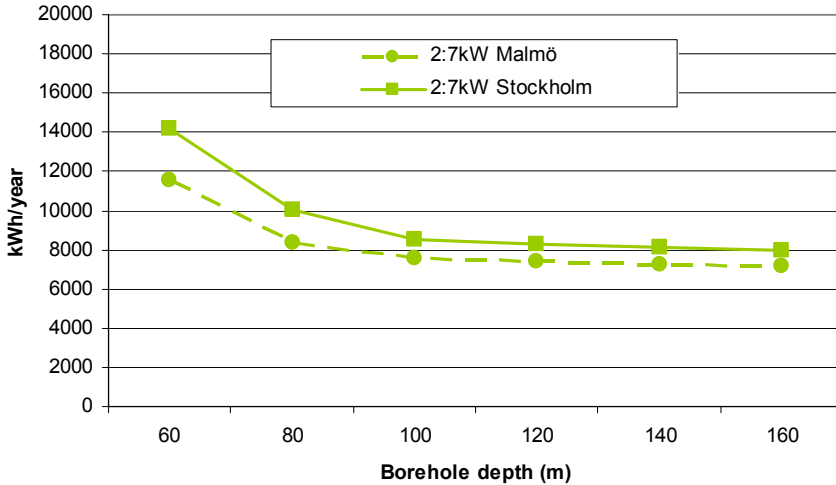

Figure 7.39 Use of electricity in system 2 (with all solar heat to the ground) in Malmö and Stockholm respectively for borehole depths 60-160 m and the power of heat pump $7kW_{th}$, $10 m^2$ flat plate solar collector, 5 years of operation.

The savings of electricity with solar heat compared to system without solar heat is shown in Figure 7.40. The system is identical as for the Figures 7.8 and 7.9 (except for the climate) and the result is also similar, but for the milder Malmö climate, the savings are negative in an ordinary sized system when all solar heat is recharged. This may be optimized by less operation time or better energy efficiency in the circulation pumps.

Savings of electricity with solar heat Malmö 5th year

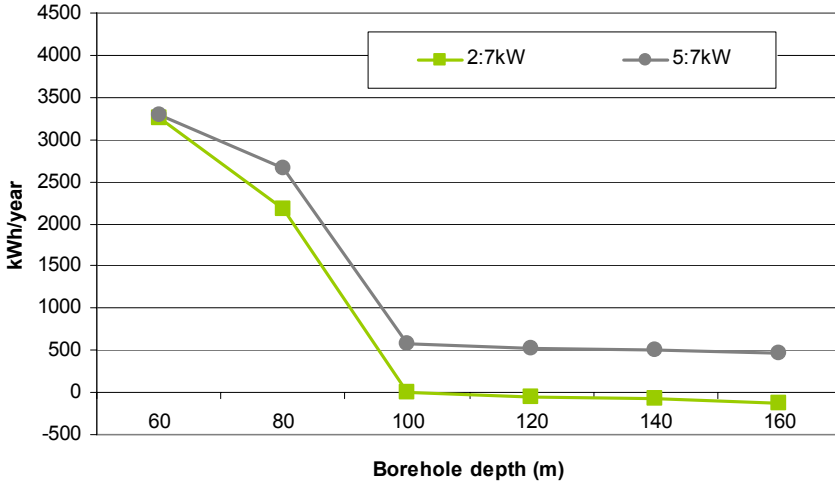

Figure 7.40 Savings of electricity in system 2 (with all solar heat to the ground) and the combined system 5 (recharging in winter and solar heated domestic hot water in summer), for boreholes depths 60 – 160 m and the power of heat pump $7kW_{th}$, $10 m^2$ flat plate solar collector, Malmö climate, 5 years of operation.

7.13 Costs

When designing a new ground-source heat pump system, the size of the heat pump and the depth of the borehole are fitted to the load and other climatic, geologic, technical and economic factors. The extra cost for drilling deeper is around 250 SEK/m and the cost for a flat plate solar collector system in single family dwellings is about 4000 - 8000 SEK/m². The actual cost for the solar collector system depends, except of the equipment cost, also on the size and the quality of the system, the home-owners own work and other factors. In Sweden there is also an investment subsidy, which is for a single family dwelling, at the moment a maximum of 7500 SEK.

In properly sized systems, the solar heat is mainly replacing electricity to the heat pump compressor and only a minor part is replacing the electricity to the auxiliary heater.

A simple economic comparison is made where the investment costs is calculated for the lifetime 20 years and with the rates of interest (minus the

inflation rate) of 3 and 5% respectively. The used fixed annual instalments factors are 0.0665 and 0.0790 respectively. The used drilling cost is 250 SEK/m and the costs for the solar collector system are calculated for 3500 and 7000 SEK/m² respectively. The input data for the heat pump is given in Table 7.4 and the electricity price is calculated for 1 SEK/kWh and 2 SEK/kWh respectively.

Table 7.4 Cost data for the heat pump used in the economic comparisons in SEK.

Heat pump costs in SEK	Including DHW	Excluding DHW	Changing compressor (once during lifetime)	Installation
6 kW	54 000	44 000	10 000	20 000
7 kW	55 000	45 000	10 000	20 000
8 kW	56 000	46 000	10 000	20 000

The total annual cost is the sum of the capital cost for the investment and the cost for the operation, which is defined as the cost for the electricity. For the heat pump, the cost for replacing the compressor once during the lifetime is included. The maintenance cost is not specified as this is regarded to be similar for the systems with solar collectors and small compared to the other costs.

There is a minimum of the total costs for a well sized system, see Figure 7.41. For all systems, the smallest heat pump gives the lowest costs for short or undersized boreholes. For deeper boreholes the difference between the sizes of the heat pump is very small.

Total cost per year, 5% interest rate

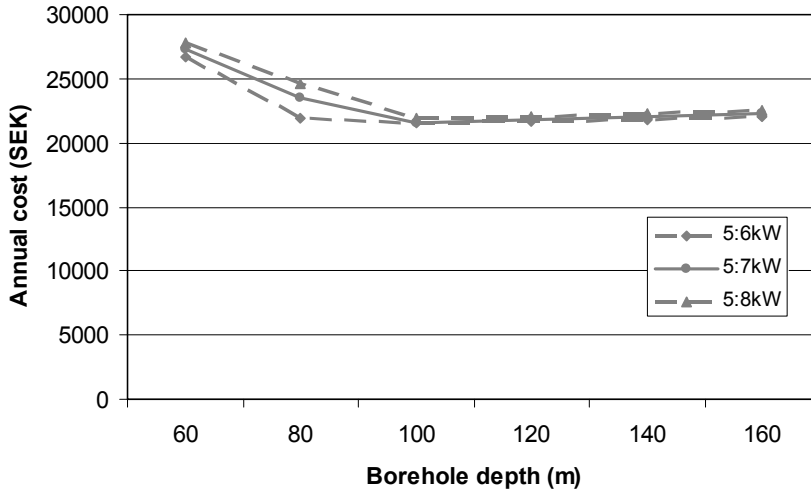

Figure 7.41 The total annual cost for the system 5 (recharging in winter and solar heated domestic hot water in summer) for the power of the heat pump 6, 7 and 8 kW_{th} respectively, with the cost of electricity 1 SEK/kWh, solar collector cost 7000 SEK/m interest rate 5%, 20 years lifetime and operation time, Stockholm climate for boreholes depths 60 – 160 m.

The lowest annual cost for system 5 with varying input data is shown in Figure 7.42. The lowest costs are found in systems with the heat pump power 6 kW_{th}. The corresponding borehole depths are 100 m for the electricity price 1 SEK/kWh. For the electricity price 2 SEK/kWh, the identified borehole depths are 140 m for the solar collector cost 3500 SEK/m² and 160 m for the solar collector cost 7000 SEK/m². This means that increased price of electricity as well as increased price of the solar collector system also gives deeper boreholes.

Lowest costs for system 5

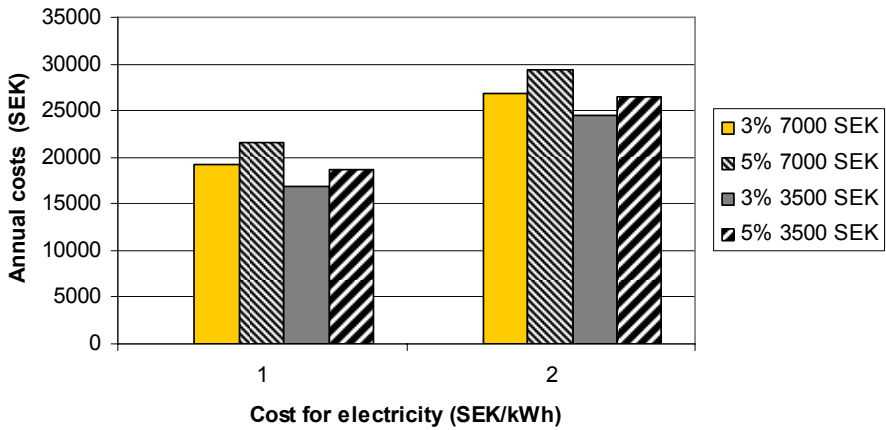

Figure 7.42 The lowest annual cost for system 5 (recharging in winter and solar heated domestic hot water in summer), with the cost of electricity 1 and 2 SEK/kWh, solar collector cost 3500 SEK/m² and 7000 SEK/m² respectively, and interest rate 3 and 5% respectively (20 years lifetime and operation time, Stockholm climate).

For the systems with solar collectors there is cost minimum for the borehole dept 100 m, but the increase in cost for deeper borehole are small, see Figure 7.43. The combined system 5, with recharging of the borehole during winter and solar heated domestic hot water in summer, gives the lowest cost, but for deeper boreholes, the total is almost the same as for the system with only solar heat to the domestic hot water (4).

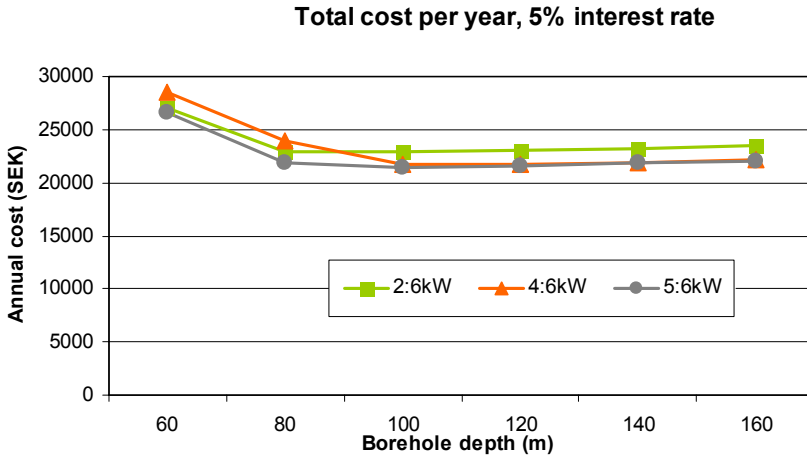

Figure 7.43 The total annual cost for the systems with solar collectors with the cost of electricity 1 SEK/kWh, solar collector cost 7000 SEK/m² and interest rate 5% (6 kW heat pump, 20 years lifetime and operation time, Stockholm climate). System 2 (all solar heat to the ground), system 4 (all solar heat to the domestic hot water) and the combined system 5 (recharging in winter and solar heated domestic hot water in summer), for boreholes depths 60 – 160 m.

In Figure 7.44 the annual cost for all four systems are shown for the 6 kW heat pump, 3% interest rate, solar collector cost of 3500 SEK/m² and the electricity price of 1 SEK/kWh. The minimum cost is for systems with 100-120 m borehole depth.

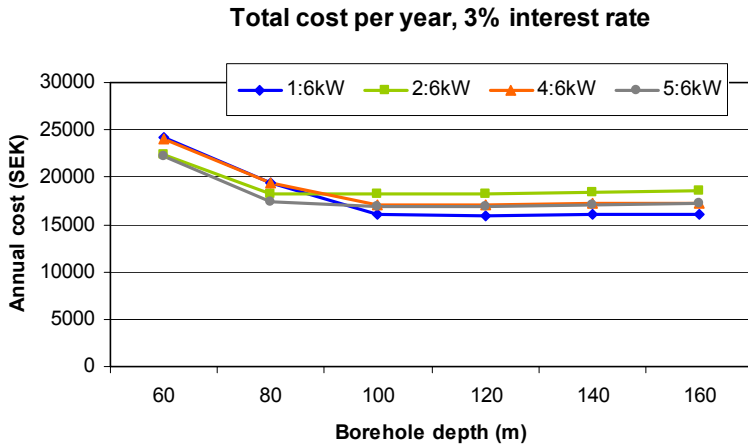

Figure 7.44 The total annual cost for all four systems with the cost of electricity 1 SEK/kWh, solar collector cost 3500 SEK/m² and interest rate 3% (6 kW heat pump, 20 years lifetime and operation time, Stockholm climate). System 1 (without solar heat), system 2 (all solar heat to the ground), system 4 (all solar heat to the domestic hot water) and the combined system 5 (recharging in winter and solar heated domestic hot water in summer), for boreholes depths 60 – 160 m.

With increased price of electricity the lowest annual cost is for deeper boreholes. If the electricity price is 2 SEK/kWh the lowest annual cost is a system with 160 m borehole for the systems not recharging with solar heat and 140 m for systems with solar recharging.

The total annual cost is the sum of the capital cost and the operation cost and the distribution between them shows in Figure 7.45 for system 1, without solar heat, and in Figure 7.46 for system 5, with the combination of recharging and solar heat to the domestic hot water.

Investment and electricity costs

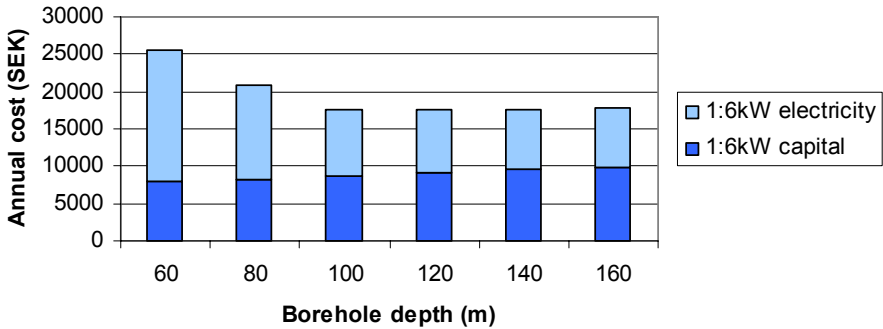

Figure 7.45 The capital and operation costs for system 1 (without solar heat) with the cost of electricity 1 SEK/kWh, solar collector cost 7000 SEK/m² and interest rate 5%, 6 kW_{th} heat pump, 20 years lifetime and operation time, Stockholm climate for boreholes depths 60 – 160 m.

Investment and electricity costs

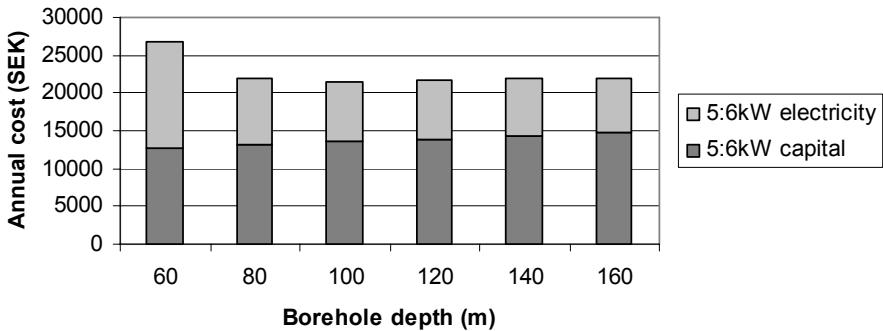

Figure 7.46 The capital and operation costs for system 5 (recharging in winter and solar heated domestic hot water in summer) with the cost of electricity 1 SEK/kWh, solar collector cost 7000 SEK/m² and interest rate 5%, 6 kW_{th} heat pump, 20 years lifetime and operation time, Stockholm climate for boreholes depths 60 – 160 m.

The advantage of using solar heat is increasing with shorter boreholes and system 5, with the combination of solar heat to the domestic hot water and recharging, gives the lowest cost, followed by system 2, only recharging.

For deep boreholes, the natural recharging is sufficient for the heat pump operation. Depending on the cost and use of solar heat, the total annual cost may be higher with solar collectors and the costs for solar heat is too high to make these systems economical when designing the system. But in an existing system with increased heating demand or decreased possibility for extracting heat from the borehole, solar heat may be economical in the system.

8 Energy balances

This Chapter shows the energy balances for the simulated systems in Sankey-diagrams.

The main energy inputs to the systems are the electricity to the heat pump, the heat from the ground and the heat from the solar collectors. The remaining input is electricity to the circulation pumps and auxiliary to heat the building and the domestic hot water. Examples of the energy balances for the four different simulated systems are shown in the Figures 8:1-4 for the reference case with the borehole depth 100 m.

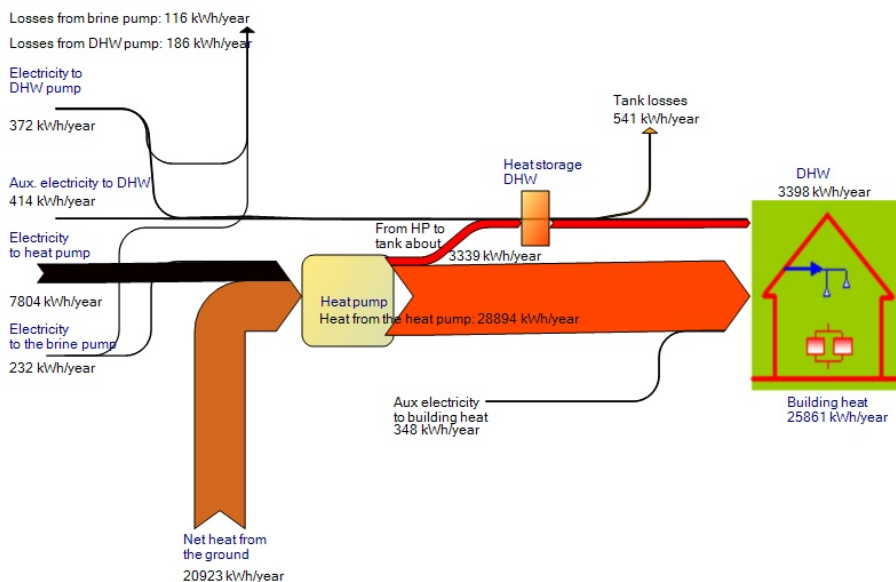

Figure 8.1. Sankey-diagram for the reference case with system 1, without solar collectors, borehole depth 100 m.

Figure 8.1 shows the result from the simulation with the energy balance for a reference case without solar collectors for 100 m borehole depth. The electricity to the circulation pumps are calculated with 50% losses. There is a small difference ($<0.2\%$) in the energy balance which is acceptable.

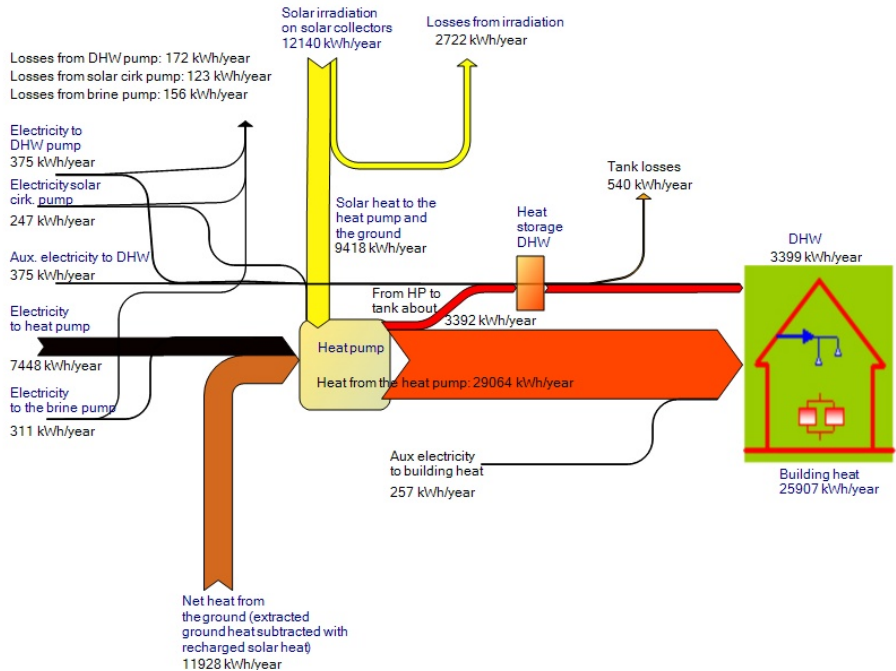

Figure 8.2. Sankey-diagram for the reference case with system 2, all solar heat to the heat pump and to the ground, borehole depth 100 m.

In system 2 (Figure 8.2), with all solar heat used in the heat pump or recharging of the ground, the net heat extracted from the ground is reduced almost to the half compared to the system without solar heat. The delivered solar heat from the solar collectors is in this case in the order of 80% of the net heat from the ground, but the electricity to the heat pump is only slightly reduced. By using solar heat for recharging of the borehole, the distance to adjacent boreholes may be reduced.

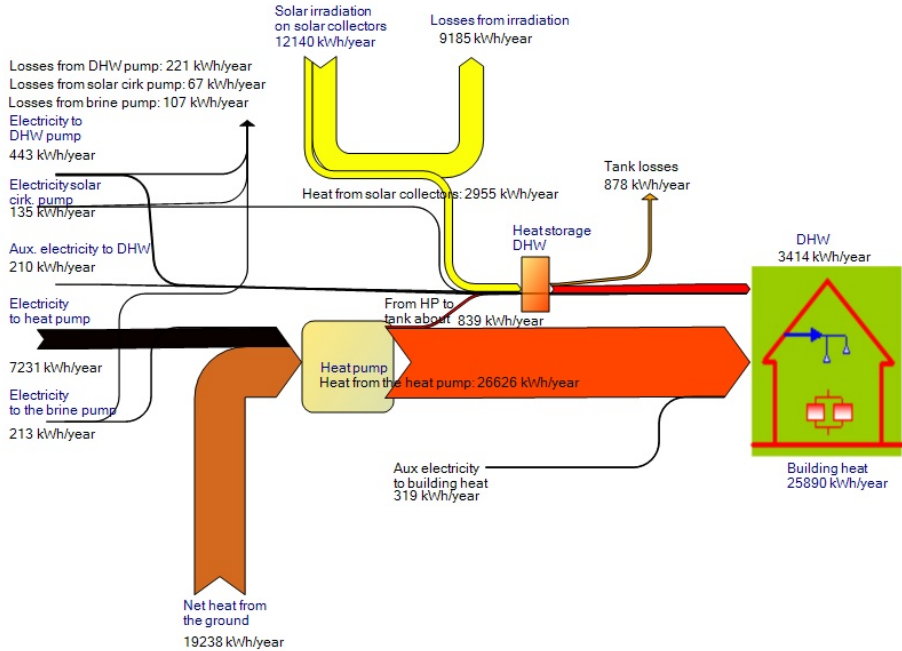

Figure 8.3. Sankey-diagram for the reference case with system 4, all solar heat to the domestic hot water, borehole depth 100 m.

When using the solar heat to the domestic hot water, the electricity demand to the heat pump is reduced more, compared to the system with all solar heat to the ground, see Figure 8.3. In this case the solar collector system is larger than the normal solar collector area in a domestic hot water system, in order to make comparisons between the systems.

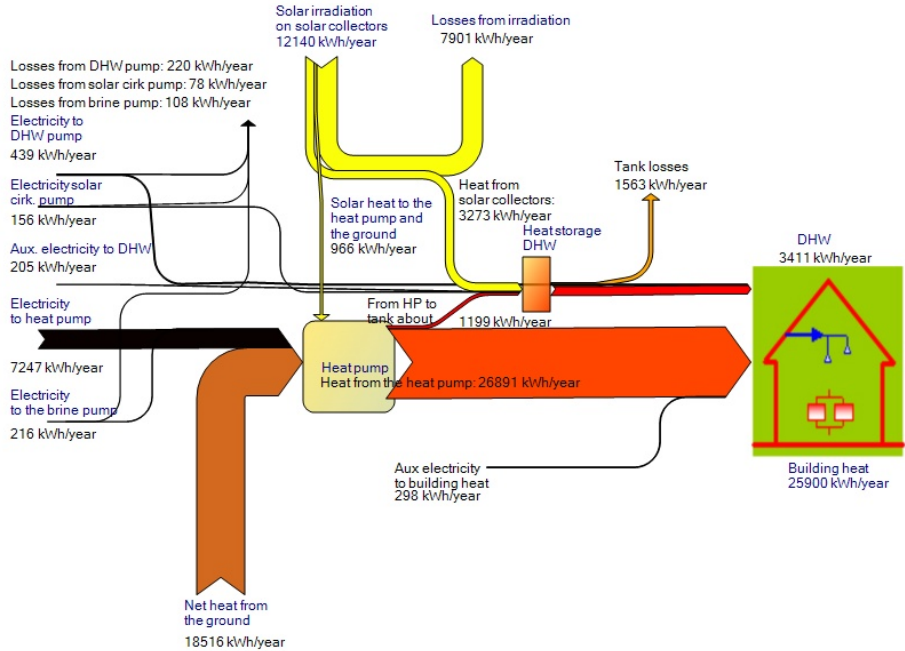

Figure 8.4. Sankey-diagram for the reference case with system 5, solar heat to the domestic hot water in March-October and solar heat to the heat pump and the ground in November-February, borehole depth 100 m and solar collector flow 1620 kg/h.

In the combination between system 2 and 4, a larger part of the solar heat is used for the domestic hot water and a smaller part during wintertime to the heat pump and the ground, see Figure 8.4. In order to get comparable systems, the flow is the same over the year in the solar system (1620 kg/h), which is higher than normal and also the solar collector area is larger as in system 4.

9 Conclusions and discussion

There are three major reasons for combining solar collectors and ground-source heat pump systems:

- To decrease the use of electricity in the system
- To raise the temperature in the borehole
- To decrease the net heat extraction from the ground

Other reasons might be the replacement of other types of heating plants with existing solar collectors e.g. replacement of a wood-fired heating plant with a ground-source heat pump - or giving a heat pump installation a green profile.

If the reason is to decrease the use of electricity, the best energy savings comes from a system where the solar collectors produce domestic hot water during summertime and, especially in systems with short boreholes, recharge the borehole during the winter. The benefit depends on the system design and for oversized depth of the boreholes, the savings of electricity from recharging might be negligible. The natural recharging from the surroundings is large during summertime, when the heating demand in the building is low. If the depth of the borehole is not undersized, the natural increase of the temperature in the borehole during summertime is enough. It is more energy efficient to use the solar heat during summer for domestic hot water, compared to recharging the borehole during summer. Recharging during summertime gives a higher temperature in the borehole, but it gives almost no savings in electricity if the system is properly sized. One reason for this is that the temperature increase is quickly lost in the ground and gives more or less only advantages in close timing with the heat extraction, the more simultaneously – the better. There is an increase in the borehole temperature when the heat pump is not in operation, but when it starts to operate, the temperature immediately decreases.

During wintertime, the temperature in the borehole is much lower as the rate of heat extraction is large, and normally the coldest month in the borehole is February. From November to February, the irradiation is low and the solar collectors are normally contributing only a small part to the domestic hot water system. The actual date for shifting the operating mode of the solar collectors may differ according to the latitude, weather conditions and system, but for the simulated system, the best efficiency was to change between domestic hot water and recharging respectively from November 1st to February 28th. The

recharging during winter increases the COP for the heat pump as the temperature in the borehole without recharging is low. The solar collector can produce heat at a low temperature and is efficient compared to the use for domestic hot water. The advantages or savings in electricity is although dependent on the size of the system. If there is almost no need for auxiliary electric heat, the advantage of recharging is low.

For systems with short boreholes, the savings in electricity may be large, especially if the solar heat can replace electricity from the auxiliary electrical heater. If the boreholes are deeper than the normal sizing, there is no savings at all with only recharging. Solar heat for domestic hot water always replaces electricity, as the operating time for the heat pump decreases, irrespective of the depth of the borehole.

If the reason for having solar heat in the system was a low temperature in the borehole, the system is probably undersized and recharging with solar heat may be very efficient. This is the same if the low temperature depends on influence from neighbouring boreholes. The net heat extraction from the borehole can be decreased and the problem with a decreasing ground temperature can be stopped. The sizing depends on the actual conditions regarding heat extraction and the thermal influence from other boreholes.

One disadvantage with recharging with solar heat with long operating times is the increased demand of electricity to the circulation pumps. The more energy efficient pumps that are used – the longer operation time may be accepted. The advantage is dependent on the sizing of the system, especially if the recharged heat is replacing auxiliary heat. The use of electricity for the circulation pumps can easily exceed the decreased use of electricity in the heat pump, if the circulation in the solar collector system and the borehole system runs whenever there is a possibility to charge to the borehole with solar heat.

In single family dwellings in Sweden, the majority of the heating demand is during wintertime and the performance of the system during this time is very important for the seasonal performance. So when comparing systems it is important to compare the performance for the whole year and to include all the electricity demands, especially to all circulation pumps.

The coefficient of performance (COP) for the heat pump can be very high in systems with solar heat, when the temperature to the evaporator is increased. Although this just gives the operating conditions for the heat pump and in the simulated systems, the SPF for the system (for a year) is low in systems with

undersized boreholes. Describing a system with a separate COP may be misleading for the overall system performance.

As systems with ground-source heat pumps and solar collectors are very complex, it is hard to give general recommendations. If the system is well-designed regarding power of the heat pump, depth of the borehole, building load and all subsystems work well, the best use of solar heat is to use it for domestic hot water during summer (March – October) and possibly recharging the borehole during winter (November – February). The optimized changing dates depend on the size of the load of the heat and the domestic hot water respectively.

A careful design of the system is important in order to minimize the use of electricity.

The decision of investments by a house owner is often a question of saving operating costs and maybe also with an environmental aspect, at least the question of installing solar collectors. In Sweden, many single family dwellings are changing their heating system to different kinds of heat pump systems. The ground-source heat pump systems normally yield the most energy savings of the heat pump systems, but as they are also the most expensive, they are normally installed in buildings with a relatively high heating demand. Converting from oil increases the electricity demand and converting from electric resistance heating, decreases the electricity demand. The electricity price will probably increase and one possibility to minimize the cost and the dependency of electricity is to install solar collectors. In heat pump systems there is a large dependency on electricity and one environmental solution is to use wind to power the heat pumps.

The savings of electricity with solar collectors depends on the system and in the simulations performed, different systems are analysed. By analysing all solar heat used for recharging the borehole or to all solar heat used to heat the domestic hot water respectively, the maximum advantage for each system is quantified. Different combinations can be nearly the sum of the saved electricity in well designed systems, but for undersized systems recharging is the most important.

New generations of energy efficient circulation pumps may imply longer operating times for recharging and can still be energy efficient for the system. Also, heat pumps are evolving continuously and they can be designed for the actual conditions e.g. the price of electricity.

Recharging with solar heat may be used in areas with thermal influence from the surrounding boreholes and this might open new possibilities to use ground-source heat pumps in areas with terraced houses with narrow gardens.

In large buildings or groups with many buildings, the possibility of using many boreholes gives other conditions for using the ground as heat storage or to the combination of heating and cooling. There is a large interest in the combination with solar collectors and the need for a careful design is even more important for large systems.

10 Used symbols and nomenclature

A = Solar collector area (in testing the aperture area is normally used – that is the area through which the solar radiation enters the solar collector (m^2))

α = absorptance for the absorber

a_1 = 1st order of heat loss coefficient at collector fluid temperature equal to ambient temperature ($W/m^2, K$)

a_2 = 2nd order of heat loss coefficient, temperature dependent term of the heat loss coefficient a_1 ($W/m^2, K^2$)

C = Effective building thermal capacitance (J)

C_p = Heat capacity of the building element ($J/(kg,K)$)

$F'(\tau \alpha)$ = Optical efficiency, the combined efficiency of the transparent cover and the absorber ($\tau * \alpha$)

G = Global irradiance on collector plane (W/m^2)

m = Mass of the building element (kg)

η = Thermal efficiency of the solar collector

Q = Heat injection rate per meter borehole (W/m)

Q_{aux} = Electricity used in the auxiliary electrical heater in the heat pump (kWh)

Q_{gain} = Internal gains (W)

Q_{hp} = Electricity used in the compressor in the heat pump (kWh)

Q_{loss} = Conductive heat loss from the house (W)

Q_{pb} = Electricity used in the brine pump in the borehole system (kWh)

Q_{ps} = Electricity used in the pump in the solar collector system (kWh)

$\sum Q_{el}$ = Total use of electricity in the system (kWh)

q = Power output from solar collector (W)

R_b = Thermal resistance of the borehole (K/(W/m))

T_a = Ambient air temperature (K)

T_b = Temperature at the borehole wall (K)

T_f = Temperature in the ground heat exchanger (K)

T_{house} = The temperature in the house (K)

T_m = Mean fluid temperature in the solar collector (K)

ΔT_i = Temperature change in the building element i (K)

τ = transmittance for the glazing

UA = Overall conductance for heat loss from the house (W/K)

Nomenclature

Absorber	The part in the solar collector where the irradiation from the sun is absorbed and converted to heat that is further transported.
COP	Coefficient of Performance. Delivered heat divided by supplied electricity.
Diffuse irradiation	Irradiation coming from the sun on a surface after the direction are scattered for the sunbeams by passing the atmosphere.
Direct irradiation	Irradiation coming from the sun on a surface, without being scattered by passing the atmosphere.
Ground source heat pump	Heat pump extracting heat from the ground (horizontal or vertical piping) or water (ground or surface water).
Global irradiation	Sum of the direct and diffuse irradiation on a surface.
SPF	Seasonal Performance Factor. Delivered heat divided by supplied electricity, over a year.

Symbols

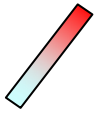

Solar collector



Temperature sensor



Pump



Auxiliary electric heater



Valve

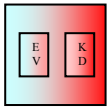

Heat pump
EV = evaporator
KD = kondenser

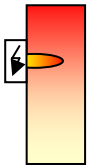

Hot water storage tank with auxiliary heater

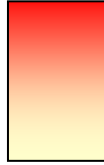

Hot water storage tank



Control central

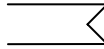

Internal heat exchanger

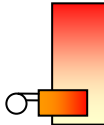

Boiler for heating

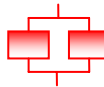

Heating distribution system

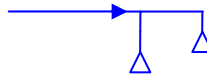

Shower



External heat exchanger

11 References

Andrén L. 2001. *Solenergi. Praktiska tillämpningar i bebyggelse* (in Swedish, Solar energy. Applications in buildings). AB Svensk Byggtjänst. Stockholm.

Bennet J., Claesson J., Hellström G. 1987. *Multipole method to compute the conductive heat flows to and between pipes in a composite cylinder*, Notes on Heat Transfer 3-1987, Depts. of Build. Physics and Math. Physics, Lund University, Sweden.

Bäckström B. 1979. *Nordic Symposium on Earth Heat Pumps Systems*. Proceedings from Symposium in Göteborg 15-16 October, 1979. Chalmers Earth Heat Pump Group.

Dalenbäck J.-O. 1990. *Third Workshop on Solar Assisted Heat Pumps with Ground Coupled Storage*. Proceedings from Workshop in Göteborg, 16-18 January 1989, Energiteknisk Analys Chalmers Industriteknik CIT 1990:3.

Duffie J.A., Beckman W.A. 1991. *Solar Engineering of Thermal Processes*. John Wiley & sons, inc., New York.

Elforsk 2008. *Miljövärdering av el – med fokus på utsläpp av koldioxid* (in Swedish, Environmental Assessment of electricity - with a focus on carbon dioxide emissions). Brochure by EME Analys AB and Profu i Göteborg AB, supported by Elforsk AB.

Energimyndigheten 2006. *Villavärmepumpar. Energimyndighetens sammanställning för värmepumpar för småhus*. (in Swedish, Heat Pumps for single-family dwellings. Compilation by Swedish Energy Agency). ET 2006:25, addition 2007.

Energimyndigheten 2007. *Energiläget 2006* (in Swedish, Energy in Sweden 2006). Swedish Energy Agency. ET 2007:49 Eskilstuna.

Energimyndigheten 2007b. *Test av cirkulationspumpar* (in Swedish, Testing of circulation pumps). Swedish Energy Agency testing laboratory. November 2007.

Energimyndigheten and SCB 2007a. *Energistatistik för småhus 2006* (in Swedish, Energy statistics for one- and two-dwelling buildings in 2006.) *Statistiska meddelanden* EN 16 SM 0701.

Energimyndigheten and SCB 2007b. *Energistatistik för småhus, flerbostadshus och lokaler 2006. Jämförande uppgifter för åren 2001-2006* (in Swedish, Summary of energy statistics for dwellings and non-residential premises for 2001-2006). Corrected version 2008-04-23 EN 16 SM 0704.

Faninger G. 1999. *Erdgekoppelte Wärmepumpen – Betriebsdaten von Anlagen in Österreich*. Proceedings from OPET-Seminar, 1999. *Erdgekoppelte Wärmepumpen zum Heizen und Klimatisieren von Gebäuden*. Brandenburgische Technische Universität Cottbus, 18-19 Mai 1999.

Hattem D.v. 1985. *Second Workshop on Solar Assisted Heat Pumps with Ground Coupled Storage*. Proceedings from Workshop in Vienna, Austria, 8-10 May 1985, Commission of European Communities, Ispra, July 1985.

Hellström G. 1982. *Duct Storage Model, Manual for Computer Code*. Dept. of Math. Physics, Lund University, Lund, Sweden.

Hellström G. 1991. *Ground Heat Storage, Thermal Analyses of Duct Storage Systems, Part I: Theory* (thesis). Dept. of Math. Physics, Lund University, Lund, Sweden.

Hellström G., Kjellsson E. 2000. *Laboratory measurements of heat transfer properties of different types of borehole heat exchangers*. Proceedings of Terrastock 2000, 8th International Conference on Thermal Energy Storage, August 28 – September 1, 2000. Stuttgart, Germany, Benner M. and Hahne E.W.P. (eds.), University of Stuttgart, Institute of Thermodynamics and Thermal Engineering.

Hellström G. 2003. *Termisk influens mellan närbelägna bergvärmebrunnar – En fallstudie för kvarteret Grönstensyxan, Norra Ängby* (in Swedish, Thermal influence between adjacent boreholes – A case study for the dwelling block Grönstensyxan, Norra Ängby). Internal report, Dept. of Mathematical Physics, Lund University.

Hässig W., Sutter D., Bigler R., Huber A. 1998. *Regeneration von Erdwärmesonden, Phase 1: Potentialabschätzung*. Forschungsprogramm Umgebungs- und Abwärme, Wärme-Kraft-Kopplung (UAW), Bundesamt für Energiewirtschaft, September 1998.

Kjellsson E. Hellström G. 1999. *Laboratory study of the heat transfer in a water-filled borehole with a C-pipe*. Internal report Dept. of Building Physics and Dept. of Mathematical Physics, Lund University, Lund 1999.

Kjellsson E. 2000. *Potentialstudie för byggnadsintegrerade solceller i Sverige. Rapport 2. Analys av instrålningsnivåer på byggnadsytor.* (in Swedish, Potential study of building integrated PV in Sweden. Report 2. Analysis of irradiation on building envelopes.) Dept of Building Physics, Lund University, Report TVBH-7216, Lund.

Kjellsson E. 2004. *Solvärme i bostäder med analys av kombinationen solfångare och bergvärmepump* (in Swedish, Solar Heating in Dwellings with Analysis of Combined Solar Collectors and Ground-Coupled Heat Pump). Licentiate thesis, Building Physics, Lund University, Sweden, Report TVBH-3047, Lund.

Klein S.A. et al 2006. *TRNSYS 16 – A TRAnSient SYstem Simulation program.* Solar Energy Laboratory, University of Wisconsin – Madison, USA, June 2006.

Kylma 2000. *Datablad för VegoCool-15.* (in Swedish, Datasheet for VegoCool-15) Kylma, AB Kylmaterial, Solna, December 2000.

Lundh M. 2007. *Evaluation of Domestic Solar heating using Case Studies and Models.* Dept of Engineering Sciences, Uppsala University, Lic. Thesis.

Mazzarella L. 1990. *Design versus simulated and measured performance of Treviglio System.* Proceedings from Third Workshop on Solar Assisted Heat Pumps with Ground Coupled Storage in Göteborg, 16-18 January 1989, Energiteknisk Analys Chalmers Industriteknik CIT 1990:3.

Melinder Å. 1997. *Termofysikaliska egenskaper för köldbärarvätskor – beräkningsprogram baserat på kapitlen 5 och 6 och tabell E1-11 i boken ”Termofysikaliska egenskaper för köldbärarvätskor – Diagram och tabeller”* (in Swedish, Thermo-physical properties of brines, calculation program based on Chapter 5 and 6 and Table E1-11 in the handbook ”Thermo-physical properties of brines – Diagrams and tabells”). Handbok nr 12. Svenska kyltekniska föreningen. Stockholm, 1997.

Mitchell J.W., Braun J.E. 1997. *Design Analysis, and Control of Space Conditioning Equipment and Systems.* Solar Energy Laboratory, University of Wisconsin – Madison.

OPET-Seminar 1999. ”Erdgekoppelte Wärmepumpen zum Heizen und Klimatisieren von Gebäuden”. Brandenburgische Technische Universität Cottbus, 18-19 Mai 1999.

Perers B. 2004. SERC, Solar Energy Research Center, Högskolan Dalarna. Personal contacts.

Perers B. 2006. *A Dynamic Collector Model for Simulation of the operation below dewpoint in Heat Pump Systems*. Proceedings from Eurosun 2006 in Glasgow 26-29 June, 2006.

Persson T. 2006. *Combined solar and pellet heating systems for single-family houses. – How to achieve decreased electricity usage, increased system efficiency and increased solar gains*. Department of Energy and Environmental Technology, KTH, Trita REFR Report No 06/56. Universitetservice US AB, Stockholm 2006.

Pfeil M., Hornberger M., Hahne E. 1996. *Solar Assisted Heating of a Business Building by Absorption Heat Pump, Vertical Ground Heat Exchangers and Solar Absorbers*. Proceedings from EuroSun'96, 16-19 September 1996, Freiburg, Germany, A. Goetzberger and J. Luther (eds.) DGS-Sonnenenergie Verlags-GmbH, München.

Reuss M., Schulz H., Wagner B. 1990. *Design and Construction of a Solar Assisted Heat Pump and Ground Coupled Storage with Vertical Heat Exchangers for Space Heating of a Two-Family House with Adjoined Office Building and Factory Hall*. Proceedings from Third Workshop on Solar Assisted Heat Pumps with Ground Coupled Storage in Göteborg, 16-18 January 1989, Energiteknisk Analys Chalmers Industriteknik CIT 1990:3.

Rönnelid M., Tepe R. 2004. *Solvärme och värmepump. Utvärdering av ett värmesystem i Uppsala* (in Swedish, Solar Collectors and Heat Pump. Evaluation of a Heating System in Uppsala). Internal report SERC, Högskolan Dalarna. January 2004.

Sanner B., Lehmann A. 1997. *Erdgekoppelte Wärmepumpen, Systeme zum Heizen und Kühlen*. Proceedings from 3.Symposium Erdgekoppelte Wärmepumpen, Systeme zum Heizen und Kühlen, 20-22 November 1997, Schloss Rauischholzhausen, IZW-Bericht 2/97.

SOU 2008. *Ett energieffektivare Sverige, Nationell handlingsplan för energieffektivisering, Bilaga till Energieffektiviseringsutredningens delbetänkande* (in Swedish, Energy-efficient Sweden. The National Action Plan for Energy-efficiency). SOU 2008:25. Stockholm.

Spante L., Bylander P., Larsson M. 1986. *Bergvärmesystem för småhus. Resultat och erfarenheter från fältmätningar* (in Swedish, Ground-Source Heat

Pumps in Dwellings. Results and Experiences from Field Measurements).
Vattenfall Älvkarlebylaboratoriet, Report no UL-FUD-B 86:14.

SVEP 2008. Facts from the Swedish Heat Pump Association SVEP (Svenska Värmepumpföreningen). Personal contacts.

Tepe R., Rönnelid M. 2002. *Solfångare och värmepump: Marknadsöversikt och preliminära simuleringsresultat* (in Swedish, Solar Collectors and Heat Pumps, Market survey and preliminary simulation results). SERC, Högskolan Dalarna ISRN DU-SERC—75—SE, March 2002.

Tepe R., Rönnelid M., Perers B. 2003. *Swedish Solar Systems in Combinations with Heat Pumps*. Proceedings from ISES Solar World Congress 14-19 June, 2003. Göteborg.

Weiss W. 2003. *Solar Heating Systems for Houses, A Design Handbook for Solar Combisystems*. IEA SHCP TASK 26, Werner Weiss editor, James & James Ltd, London, 2003.

11.1 Internet

www.energypluspumps.eu

Energy+ Pumps Project (EU) (visited 2008-08-07)

www.estif.org/solarkeymark

Solar Keymark (visited 2008-08-07)

www.folksam.se

Folksam (visited 2008-08-07)

www.sp.se

SP, Technical Research Institute of Sweden (visited 2008-08-07)

11.2 Software

EED Earth Energy Designer ver.3.09, Blomberg T., Claesson J., Eskilson P., Hellström G. and Sanner B. LTH, July 2008. www.buildingphysics.com

METEONORM, Meteotest Version 5.0 Edition 2003. www.meteororm.com

PVSYST 3.0, Ecole Polytechnique Federale de Lausanne, University of Geneva. www.pvsyst.com

TRNSYS 16.01.0002 with Simulation Studio 4.2. TRNSYS A Transient Simulation Program. S.A. Klein, W.A. Beckman, J.W. Mitchell, J.A. Duffie, N.A. Duffie, T.L. Freeman, J.C. Mitchell, J.E. Braun, B.L. Evans, J.P. Kummer, R.E. Urban, A. Fiksel, J.W. Thornton, N.J. Blair, P.M. Williams, D.E. Bradley, T.P. McDowell, M. Kummert and D.A. Arias. Solar Energy Laboratory, University of Wisconsin-Madison, USA, June 2006.
<http://sel.me.wisc.edu/trnsys/>

Dissertations from Building Physics, Lund University, Sweden

Bankvall C G	Natural Convective Heat Transfer in Insulated Structures. Report 38. Heat Transfer in Insulation and Insulated Structure. Report 39.	1972
Sandberg P-I	Moisture Balance in Building Elements Exposed to Natural Climatic Conditions. Report 43. (in Swedish)	1973
Bomberg M	Moisture Flow through Porous Building Materials. Report 52.	1974
Samuelsson I	Moisture Transfer in Steel Deck. Report 67. (in Swedish)	1976
Andersson A-C	Internal Additional Insulation. Thermal Bridges, Moisture problems Movements and Durability. TVBH-1001. (in Swedish)	1979
Kronvall J	Air Flows in Building Components. TVBH-1002.	1980
Jóhannesson G	Active Heat Capacity. Models and Parameters for the Thermal Performance of Buildings. TVBH-1003.	1981
Hagentoft C-E	Heat Loss to the Ground from a Building. Slab on the Ground and Cellar. TVBH-1004.	1988
Harderup L-E	Concrete Slab on the Ground and Moisture Control. Verification of some Methods to Improve the Moisture Conditions in the Foundation. TVBH-1005.	1991
Bornehag C-G	Mönsteranalys av inomhusluft – Undersökning av luftkvalitet i sjuka hus med flytspackelproblem. BFR Report no R23:1994. Swedish Council of Building Research. Stockholm. (in Swedish)	1994
Blomberg T	Heat Conduction in Two and Three Dimensions. Computer Modelling of Building Physics Applications. TVBH-1008.	1996
Roots P	Heat Transfer through a Well Insulated External Wooden Frame Wall. TVBH-1009.	1997
Arfvidsson J	Moisture Transport in Porous Media. Modelling Based on Kirchhoff Potentials. TVBH-1010.	1998

Harderup E	Methods to select corrections for moisture calculations at variable external climatic data. TVBH–1011 (in Swedish)	1998
Adalberth K	Energy Use and Environmental Impact of New Residential Buildings. TVBH–1012.	2000
Engdahl F	Air – for Health and Comfort. An Analysis of HVAC Systems' Performance in Theory and Practice. TVBH-1013	2002
Johansson D	Modelling Life Cycle Cost for Indoor Climate Systems. TVBH-1014	2005
Hägerhed Engman L	Indoor environmental factors and their association with asthma and allergy among Swedish pre-school children. TVBH-1015	2006
Svennberg K	Moisture Buffering in the Indoor Environment. TVBH-1016	2006
Burke S	Building Physics Tools: Needs, Use and the Lack of Use in the Building Process, Modelling Non-Isothermal Moisture Flow and Frost Penetration. TVBH - 1017	2009
Kjellsson E	Solar Collectors Combined with Ground-Source Heat Pumps in Dwellings – Analyses of System Performance. TVBH - 1018	2009