



LUND UNIVERSITY

Reliability-based Assessment of Concrete Dam Stability

Westberg, Marie

2010

[Link to publication](#)

Citation for published version (APA):

Westberg, M. (2010). *Reliability-based Assessment of Concrete Dam Stability*. [Doctoral Thesis (compilation), Division of Structural Engineering].

Total number of authors:

1

General rights

Unless other specific re-use rights are stated the following general rights apply:

Copyright and moral rights for the publications made accessible in the public portal are retained by the authors and/or other copyright owners and it is a condition of accessing publications that users recognise and abide by the legal requirements associated with these rights.

- Users may download and print one copy of any publication from the public portal for the purpose of private study or research.
- You may not further distribute the material or use it for any profit-making activity or commercial gain
- You may freely distribute the URL identifying the publication in the public portal

Read more about Creative commons licenses: <https://creativecommons.org/licenses/>

Take down policy

If you believe that this document breaches copyright please contact us providing details, and we will remove access to the work immediately and investigate your claim.

LUND UNIVERSITY

PO Box 117
221 00 Lund
+46 46-222 00 00

Report TVBK-1039
ISSN 0349-4969
ISRN:LUTVDG/TVBK-1039/10-SE(255)

Reliability-based assessment of concrete dam stability

Marie Westberg

Doctoral Thesis

Lund University
Division of Structural Engineering
P.O. Box 118
SE-221 00 Lund, Sweden

Telephone: +46 46 222 95 03
Telefax: +46 46 222 42 12
www: <http://www.kstr.lth.se>

Preface

The research presented in this thesis was first carried out as a part of the Swedish research consortium *VBT* (Road/Bridge/Dam/Tunnel, Väg/bro/damm/tunnel). Funding was provided by Elforsk AB, Vinnova and Lund University.

The later part was carried out as a part of the *Swedish Hydropower Centre* (SVC). SVC has been established by the Swedish Energy Agency, Elforsk and Svenska Kraftnät together with Luleå University of Technology, The Royal Institute of Technology, Chalmers University of Technology and Uppsala University.

Participating hydro power companies are: Andritz Hydro, E.ON Vattenkraft Sverige, Fortum Generation, Holmen Energi, Jämtkraft, Karlstads Energi, Linde Energi, Mälarenergi, Skellefteå Kraft, Sollefteåforsens, Statkraft Sverige, Statoil Lubricants, Sweco Infrastructure, Sweco Energuide, SveMin, Umeå Energi, Vattenfall Research and Development, Vattenfall Vattenkraft, VG Power and WSP.

The main part of the work has been carried out at Vattenfall AB Hydropower, but with regular visits and supervision at the Division of Structural Engineering, Lund University.

Many people have earned my gratitude during these years;

My supervisor Professor Sven Thelandersson, my co-supervisors Professor Jan Alemo and Lic. Eng. Stefan Berntsson, and my supervisor while visiting TU Delft, Professor Ton Vrouwenvelder, for encouragement, discussions and help

Those involved in different parts, giving ideas and help; my co-authors Dr. Fredrik Johansson, Professor Tarcísio B. Celestino, Dr Christian Bernstone and Dr. Joakim Jeppson, master thesis students M.Sc. Lucas Ahlsén Farell and M.Sc. Jill Holmberg, and Professor Georg Lindgren are especially worth mentioning

Those helping with comments on written material, special thanks to Dr. Martin Hansson, M.Sc. Malte Cederström and Dr. Des N. D. Hartford

My colleagues at Vattenfall AB Hydropower, especially Karin, Sezar and Claes-Olof, and my colleagues at the Division of Structural Engineering, Lund University, for support, amusement, encouragement, for answering lots of questions and for help in everyday-life

My friends, mother, father, sister and brother, and not least my loved ones Rickard and Kristian for everything.

Marie Westberg

Stockholm, February 2010

Abstract

Risk management is increasingly used in dam safety and includes risk analysis, risk evaluation and risk reduction. Structural Reliability Analysis (SRA) is a probabilistic methodology that may be used in the risk assessment process. SRA has been frequently used for calibration of partial factors in limit state design codes for structures (not dams). In a reliability analysis a mathematical description of the failure mode, a limit state function, is defined. All parameters describing the limit state function should be random variables and are described by stochastic distributions (or, where appropriate, a deterministic value). The safety index (or probability of failure) may be determined by e.g. First Order Reliability Method and the result is compared to a target safety index to determine if the structure is safe enough.

Several difficulties exist in the use of SRA for concrete dams, mainly due to the fact that only a few examples of such analysis for dams exist. One difficulty is how to define the failure modes. In this thesis a complete system of failure modes is identified, where failure is considered as a series system of “failure in the concrete part”, “failure in the concrete-rock interface” and “failure in the rock mass”. Failure in the concrete-rock interface may occur due to sliding or overturning. Sliding is the joint occurrence of sliding with a partially bonded contact (fails at very small displacement) and sliding with broken contact (fails at larger displacement) and both have to occur for sliding to occur, hence they are treated as a parallel system. Adjusted overturning is a combination of overturning and crushing of the concrete or crushing of the rock.

A substantial part of the work has been to define the necessary input data.

- Cohesion in the interface is very important. Due to the expected brittle failure in a partly intact interface, treatment of the shear resistance as a brittle parallel system is proposed.
- Description of the headwater results in a series system; either failure occurs for water levels at retention water level (rwl) or for water levels above rwl, the latter described by an exponential distribution.
- Uplift is one of the most important loads. A geostatistical simulation procedure is presented, where the hydraulic conductivity field of the foundation is described by a variogram and uplift is simulated by a FE-analysis. This methodology is demonstrated to be very useful and gives estimates of the statistical distribution of uplift. Three papers on this subject are included; the first is a description of the methodology, the second presents a sensitivity analysis performed for a large number of different combinations of input data and the last is an application to a Brazilian dam, where water pressure tests and monitoring results are available.

In two papers SRA is applied to concrete dams and the system reliability is determined. In the first paper a spillway section where information of e.g. cohesion, friction angles etc. were available is analysed. In the last paper an idealized dam and a power intake structure are analysed.

The conclusions are that SRA may be used for assessment of concrete dam stability and that it is well fitted for the dam safety risk management process. Every dam is a unique prototype and SRA enables specific behaviour and properties of a certain structure to be taken to consideration. The system reliability analysis is a very valuable tool in understanding the relationship between failure modes and enables the safety for the whole structure to be determined. In a reliability analysis the most important parameters may be identified and thus safety measures can be focused where it gives the best possible output. A general safety consideration is that development of the safety concept for concrete dams, from deterministic to probabilistic or semi-probabilistic, will give a known and more uniform level of safety.

Keywords: structural reliability analysis, probability, concrete dam, stability, assessment, uplift, system reliability

Sammanfattning

Systematisk riskhantering används allt mer inom dammsäkerhetsområdet och inkluderar riskanalys, riskvärdering och riskreducering. Tillförlitlighetsanalys (SRA) är en probabilistisk metod som kan användas i riskvärderingsprocessen. SRA har använts för att kalibrera partialkoefficienter för dimensioneringsriktlinjer för konstruktioner (dock ej för dammar). I tillförlitlighetsanalysen definieras ett så kallat gränstillstånd, en matematisk beskrivning, för varje brottmod. Alla parametrar som beskriver gränstillståndet ska vara slumpvariabler och beskrivas med stokastiska fördelningar (eller, där så är lämpligt, av ett deterministiskt värde). Säkerhetsindex (eller brottsannolikhet) kan beräknas med tex First Order Reliability Method (FORM) och resultatet jämförs med ett kravvärde på säkerhetsindex för att bedöma om konstruktionen är tillräckligt säker.

Flera svårigheter finns med användningen av SRA för betongdammar, framförallt eftersom få exempel på sådana analyser finns redovisade. En svårighet är hur brottmoder skall definieras. I denna avhandling identifieras ett komplett system av brottmoder och brott för dammen betraktas som ett seriesystem av ”brott i betongdelen”, ”brott i kontakten mellan betong och berg” och ”brott i bergmassan”. Brott i kontakten mellan betong och berg kan inträffa genom glidning eller stjälpning. Glidning sker om både glidning med delvis intakt kontakt och glidning med bruten kontakt inträffar (de sker vid liten förskjutning respektive större förskjutning) och betraktas därför som ett parallellsystem. Stjälpning är en kombination av stjälpning och krossning av betong eller berg.

En stor del av arbetet har handlat om att definiera nödvändig indata:

- Kohesion i kontakten är väldigt viktigt. Eftersom ett brott med existerande kohesion troligen är sprött, föreslås att skjuvhållfastheten i detta fall betraktas som ett sprött parallellsystem.
- Beskrivningen av uppströmsvattenytans nivå resulterar i ett seriesystem; antingen inträffar brott för vattennivåer vid dämningegräns (dg) eller för vattennivåer över dg, det senare beskrivs av en exponentialfördelning.
- Upptryck är en av de viktigaste lasterna. En geostatistisk simuleringsprocedur presenteras. I denna beskrivs det hydrauliska konduktivitetssfältet för berget under dammen med hjälp av ett variogram och upptryck simuleras med hjälp av en FE-analys. Denna metodik visas vara väldigt användbar och ger uppskattning av den statistiska fördelningen av upptryck. Tre artiklar på detta tema är inkluderade; i den första beskrivs metodiken, i det andra görs en känslighetsanalys för ett stort antal olika kombinationer av indata och den tredje visar tillämpning på en brasiliansk damm, där resultat från vattenförlustmätningar och upptrycksmätningar används som indata.

I två artiklar visas tillämpningen av SRA på betongdammar och systemtillförlitligheten beräknas. I den första analyseras en utskovsdel med hjälp av tillgänglig information om

kohesion, friktionsvinklar mm. I den andra analyseras en idealiserad dam och en intagsdamm.

Slutsatserna är att SRA kan användas för utvärdering av betongdammars stabilitet och att det passar väl i den systematiska riskhanteringsprocessen. Varje damm är en unik prototyp och SRA möjliggör att hänsyn tas till beteende och egenskaper hos en specifik konstruktion. Systemtillförlitlighetsanalys är ett mycket värdefullt verktyg för att förstå relationer mellan olika felmoder och möjliggör beräkning av säkerheten för hela konstruktionen. I en tillförlitlighetsanalys kan de viktigaste parametrarna identifieras och på så sätt kan säkerhetshöjande åtgärder fokuseras på de områden där det ger bäst effekt. En generell säkerhetsbetraktelse är att en utveckling av säkerhetskoncept för betongdamm, från deterministisk till probabilistisk eller semi-probabilistisk, skulle ge en jämnare säkerhetsnivå.

Sökord: Tillförlitlighetsanalys, sannolikhet, betongdamm, stabilitet, utvärdering, upptryck, systemtillförlitlighet.

Table of contents

PREFACE	I
ABSTRACT	III
SAMMANFATTNING	V
TABLE OF CONTENTS	VII
APPENDED PAPERS	XI
NOMENCLATURE	XIII
ABBREVIATIONS	XIII
DEFINITIONS	XIV
SYMBOLS	XV
1. INTRODUCTION	1
1.1 BACKGROUND	1
1.2 OBJECTIVES OF RESEARCH AND FUTURE AIM	2
1.3 LIMITATIONS	2
1.4 RESEARCH CONTRIBUTION	3
1.5 OUTLINE	3
2. RISK MANAGEMENT AND DAM SAFETY RISK MANAGEMENT	5
2.1 GENERAL RISK MANAGEMENT OF TECHNICAL SYSTEMS	5
2.1.1 Risk analysis	6
2.1.2 Risk evaluation process	9
2.1.3 Risk reduction	14
2.2 DAM SAFETY IN SWEDEN	14
2.2.1 Dam safety today	18
2.2.2 Comments	19
2.3 RISK MANAGEMENT IN DAM SAFETY	19
2.4 DAM SAFETY AT VATTENFALL	22
2.4.1 Risk management process	22
3. SAFETY CONCEPTS	29
3.1 UNCERTAINTY MODELLING	29
3.1.1 Modelling uncertainty	30
3.2 STRUCTURAL RELIABILITY ANALYSIS	31
3.2.1 Basic reliability problem	32
3.2.2 First-Order methods	34
3.2.3 Second-Order Methods	38
3.2.4 Simulation methods	38
3.2.5 Analysis of implicit limit state functions	38
3.3 SYSTEM RELIABILITY	39
3.3.1 Reliability bounds	41
3.3.2 Integration	42
3.3.3 Monte Carlo simulation	43
3.3.4 Failure of brittle parallel systems	44
3.4 BAYESIAN UPDATING	44
3.5 METHODS FOR RELIABILITY DESIGN	45
3.5.1 Method and calibration of partial factors	45
3.6 TARGET SAFETY INDEX	48
3.6.1 Target safety index in different structural codes	48
3.6.2 Calibration to existing practice	52

4. CONCRETE DAMS, FAILURE MODES AND DESIGN	55
4.1 CONCRETE DAMS IN SWEDEN	55
4.2 FAILURES OF CONCRETE DAMS	58
4.2.1 <i>Causes of failure</i>	58
4.3 FAILURE MODES FOR ANALYSIS	59
4.3.1 <i>Sliding</i>	60
4.3.2 <i>Overstressing</i>	65
4.3.3 <i>Overturning</i>	66
4.3.4 <i>System</i>	71
5. STRUCTURAL RELIABILITY ANALYSIS IN DAM SAFETY	73
5.1 TARGET SAFETY INDEX FOR DAMS	73
5.1.1 <i>Calibration of target safety index</i>	74
5.2 PREVIOUS WORK ON STRUCTURAL RELIABILITY ANALYSIS OF CONCRETE DAMS	77
5.3 PARTIAL FACTOR DESIGN GUIDELINES FOR CONCRETE DAMS	84
5.4 STRUCTURAL RELIABILITY IN DAM SAFETY IN THE NEAR FUTURE	88
6. RANDOM VARIABLES	91
6.1 SELF WEIGHT	92
6.2 STRENGTH OF CONCRETE AND ROCK	93
6.2.1 <i>Cohesion of concrete-rock interface</i>	93
6.2.2 <i>Internal friction angle of the concrete-rock interface</i>	100
6.2.3 <i>Basic friction angle and dilatation</i>	100
6.2.4 <i>Friction angle and cohesion of rock mass</i>	101
6.2.5 <i>Basic friction angle and dilatation angle of rock joints</i>	101
6.2.6 <i>Shear strength of concrete lift joints</i>	102
6.2.7 <i>Compressive and tensile strength of concrete</i>	102
6.3 HEADWATER	103
6.3.1 <i>Flows in unregulated and regulated rivers</i>	103
6.3.2 <i>Calculation of design flow</i>	104
6.3.3 <i>Treatment of headwater level</i>	105
6.3.4 <i>Operational or functional failures</i>	109
6.4 UPLIFT	109
6.4.1 <i>Geostatistical simulation methodology and results</i>	110
6.4.2 <i>Influence of increased head</i>	111
6.4.3 <i>Influence of temperature changes</i>	114
6.4.4 <i>Description of uplift for $h_w > h_{rwl}$</i>	116
6.5 ICE LOADS	118
6.5.1 REASON FOR ICE LOADS	119
6.5.2 <i>Creep</i>	121
6.5.3 <i>Time of peak loads</i>	121
6.5.4 <i>Other considerations</i>	122
6.5.5 <i>Testing and modelling</i>	123
6.5.6 <i>Load values</i>	124
6.5.7 <i>Distribution used</i>	126
6.6 SYSTEM	127
7. SHORT SUMMARIES OF APPENDED PAPERS	129
PAPER I	129
PAPER II	129
PAPER III	129
PAPER IV	130
PAPER V	130
OTHER PUBLICATIONS	130

8. CONCLUSIONS	133
8.1 GENERAL SAFETY CONSIDERATIONS	133
8.2 FURTHER RESEARCH NEEDS	134
9. REFERENCES	137
APPENDED PAPERS	

Appended Papers

- Paper I** *Westberg, M. C. & Johansson, F. System Reliability of Concrete Spillway with respect to foundation stability - application to a spillway. Submitted to Journal of Geotechnical and Geoenvironmental Engineering 2010.*
- Paper II** *Westberg, M.C. (2009). Reliability Analysis of Idealized dam and Power Intake Structure. In Proceedings of the 10th International Conference on Structural Safety and Reliability, Osaka, Japan.*
- Paper III** *Westberg, M. (2009). Geostatistical approach for statistical description of uplift pressures: Part I. Dam Engineering 19 (4): 241–256.*
- Paper IV** *Westberg, M. (2009). Geostatistical approach for statistical description of uplift pressures: Part II. Dam Engineering 20 (1): 39–58.*
- Paper V** *Westberg, M. C. & Celestino, T.B. Variogram Estimation of Hydraulic Conductivity Field Based on Water Pressure Tests for Probabilistic Evaluation of Uplift Pressure. Submitted to Computers and Geotechnics 2010.*

In Paper I the definitions of failure modes and parameters as well as writing was jointly done by Marie Westberg and Fredrik Johansson. Calculations were done by Marie Westberg.

In Paper V Tarcísio Celestino provided the results from water loss test, site and structure information and uplift monitoring results. Marie Westberg did most of the input data analysis, simulations, analysis of results and writing. Tarcísio Celestino was supporting with knowledge, improvements of simulations and analysis and comments and revisions on the paper.

Nomenclature

Abbreviations

ALARP	As Low As Reasonably Practicable
BKR	Swedish design regulation
CDF	Cumulative distribution function
CEB-FIP	The International Federation for Structural Concrete
CIB	International Council for Research and Innovation in Building and Construction
EN1990, Eurocodes	European design standard
ETA	Event tree analysis
FE	Finite element
FERC	Federal Energy Regulatory Commission
FERM	Finite element reliability method
FMEA, FMECA	Failure modes and effect analysis, Failure modes, effect and criticality analysis
FORM	First order reliability method
FTA	Fault tree analysis
HSE	Health and Safety Executive, UK
ICOLD	International Commission On Large Dams
IEC	International Electrotechnical Commission
IRGC	International Risk Governance Council
JCSS	Joint Committee on Structural Safety
LSF	Limit state function
MC	Monte Carlo
NKB	Nordic Committee on Building Regulation
PDF	Probability density function
RIDAS	Riktlinjer för Dammsäkerhet, Swedish guidelines on Dam Safety
rwI	Retention water level
SORM	Second order reliability method
SRA	Structural reliability analysis
VASO	Vattenregleringsföretagens samarbetsorgan

Definitions

Design point	Point on limit state surface giving the safety index
Consequence	Unwanted outcome of event
Deterministic	Describing a process with an outcome that is always the same for a given set of inputs
Failure criteria	Criteria in guideline/design code to account for a failure mode
Failure mode	The manner in which a failure can occur, failure mechanism
Hazard	Threat, source of potential harm
Limit state	A set of performance criteria (e.g. stability) that must be met when the structure is subject to loads. Can be either ultimate limit state or serviceability limit state.
Limit state function	Function describing the limit state of interest.
Probability	Estimate of likelihood of occurrence of event, or magnitude of uncertain quantity
Risk	A measure of the probability and severity of an adverse effect to health, property or the environment (Probability · consequence of unwanted event)
Risk assessment	Process of deciding if present risk is tolerable or not (includes risk analysis and risk evaluation)
Risk analysis	Process of identifying and estimating the risk to individuals, population, environment, society etc from hazards
Risk evaluation	Process to examine and judge the significance of risk
Risk management	Complete process of risk assessment and risk control
Safety factor	A multiplier applied to the calculated maximum load to which a structure will be subjected

Symbols

Notation	Explanation	Unit
α	Sensitivity factor	-
a	Parameter of Beta distribution	[--]
A	Base area	m ²
A_c	Area with cohesion	m ²
β	Safety index	-
β_{target}	Target safety index	-
b	Parameter of Beta distribution	[--]
c	Cohesion (in concrete-rock contact)	N/m ²
c_m	Cohesion of rock mass	N/m ²
c_n	Cohesion of an element	N/m ²
C	Random variable describing the uplift force	-
C_e	Random variable describing the uplift force for $h_w > h_{rwl}$	-
C_m	Random variable describing the moment of uplift	-
C_{me}	Random variable describing the moment of uplift for $h_w > h_{rwl}$	-
d	Part of area with $c = 0$	-
d_e	Head water level above rwl	m
E	Event	-
E	Expected value	[--]
E_d	Effect of actions	[--]
Φ	Cumulative distribution function of the standard normal distribution	-
ϕ	Friction angle	°
ϕ_b	Basic friction angle	°
ϕ_{bj}	Basic friction angle along joint	°
ϕ_i	Internal friction angle (in concrete-rock contact)	°
ϕ_m	Internal friction angle in rock mass	°
f_{ck}	Compressive strength of concrete	N/m ²
$f_{cm, is}$	Compressive strength of concrete in situ	N/m ²
f_x	Probability density function	-
$F_x = F(x)$	Cumulative distribution function	-
γ	Partial safety factor	-
G	Self weight	N/m ³
$G(\mathbf{x})$	Limit state function	-
$g(\mathbf{y})$	LSF in standard normal space	-
$g_L(\mathbf{y})$	Linearised LSF in standard normal space	-
h_{rwl}	Retention water level (depth)	m
h_w	Head water level (depth)	m
i	Dilatation angle	°
i_j	Dilatation angle along joint	°
I	Moment of inertia	m ⁴
I	Ice load	N
K	Hydraulic conductivity	m/s

λ	Parameter of exponential distribution	-
μ	Mean	[--]
M_R	Resisting moment	Nm
M_R^*	Resisting moment around *, * is defined by the capacity of concrete and rock	Nm
M_S	Overturning moment	Nm
M_S^*	Overturning moment around *, * is defined by the capacity of concrete and rock	Nm
M_x	Moment around point x	Nm
N	Normal force (normal to sliding surface)	N
n	Number of elements	-
n_{c0}	Number of elements with $c = 0$	-
P	Probability	-
p_f	Probability of failure	-
Q	Flow	m ³ /s
Q	Load effect	N
r	Range (correlation distance)	m
r	Parameter of Beta distribution	[--]
$\rho_{1,2}$	Correlation between E1 & E2	-
R	Resistance	[--]
R_{cr}	Crushing resistance	N/m ²
R_d	Design value of resistance variables	[--]
s	Water level above rwl	
S	Load action (Sollicitation)	[--]
σ	Standard deviation	[--]
S_f	Safety factor	-
σ_n	Normal stress	N/m ²
τ	Shear stress	N/m ²
τ_{peak}	Peak shear stress	N/m ²
t	Parameter of Beta distribution	[--]
T	Shear force (parallel to sliding surface)	N
T_R	Shear capacity	N
U	Uplift force	N
U_d	Uplift force in case of linearly decreasing uplift pressure	N
U_{dm}	Moment of uplift pressure in case of linearly decreasing uplift pressure	Nm
U_m	Moment of uplift pressure	Nm
V	Variance	[--]
V_x	Coefficient of variation	-
\mathbf{x}	Basic variables	-
\mathbf{y}	Standard normal variables	-
y^*	Design point	-
y_{ip}	Distance to centre of gravity	m
Z	Limit state function	-

1. Introduction

1.1 Background

Sweden has a large number of dams of increasing age. They represent a considerable value in terms of fixed capital assets and future generation profits. The consequences of a dam failure could be significant, in casualties and/or in economic and environmental damage, and safety is therefore given highest priority.

Design of infrastructures (dams, bridges, house etc) has been based on safety factors. During the 1970's new design guidelines, based on partial factors, were developed and later introduced in e.g. bridge and house design. By applying larger partial factors for loads and other parameters of large uncertainty than those with smaller uncertainty, the safety level was made more independent of load case and material (NKB 55, 1987). This resulted in better material use and more uniform, but sustained, safety level. Design guidelines based on partial factors are e.g. BKR (2003) and Eurocode (EN1990, 2004). Dam design is, in Sweden as well as most of the world, still based on safety factors. One reason is that the dam building era was coming to an end when the new design concepts were developed.

Partial factors in other areas were calibrated from existing design standards by use of reliability-based, or probabilistic, methodology. Reliability-based methodology is particularly useful for evaluation of existing structures and offers the possibility of rational integration of specific information concerning a certain object. It also offers good possibilities to implement successively additional information available, from e.g. investigations, testing and monitoring.

Probabilistic risk analysis is necessary to assess the relative contribution of different factors to the overall risk (Pate-Cornell, 1994). The results can be used at least in three different ways:

- For optimal allocation of a fixed safety budget
- To minimize the costs of achieving a target safety level or
- To prove to someone (corporate managers, regulators, interest groups etc) that the facility is safe enough or safer than it was before.

Design codes are formulated from a general point of view. High randomness in loads is difficult to handle, and simplifications are made to be on the safe side. This means that, in some cases, more refined statistical description of loads and resistances in the probabilistic analysis can be used to verify that the safety is sufficient in the existing state, so that expensive and unnecessary reconstruction measures can be avoided and resources be used more efficiently.

The combination of increasing age, with its associated problems, new methods for calculation of design floods and increasing demands by society to ensure a high level of

safety have resulted in upgrading and rebuilding needs for dams. When safety is re-evaluated it is important that evaluation is based on modern safety concepts.

1.2 Objectives of research and future aim

The objectives of this thesis is to

- Describe and demonstrate the capability of applying reliability-based methodology for assessment of concrete dams and how this fits into the dam risk management process.
- Compile and document present knowledge of relevant statistic information of resistance and load parameters for concrete dams.

To do this it is necessary to describe how dam safety assessment is performed today, what is meant by reliability-based evaluation and how this can be used in dam safety and, evidently, what further development is needed to implement it in this area. Special focus has been on

- Defining failure modes and limit state functions for concrete gravity and buttress dams
- Compile statistical description of shear strength properties and loads, especially uplift that is of major importance for dams
- Test the methodology for real dam structures

The motive for the above objectives is that this is the basis needed to

- Present a reliability based methodology to be used as part of the assessment phase of dams, e.g. when an existing structure does not fulfil general safety standards. This methodology should also be possible to use for design of new dams
- Formulate new guidelines for assessment of existing dams and design of new dams. To end up with a consistent handling of safety, this should be based on one safety concept only. This could be the partial factor concept, or if more appropriate, a reliability-based methodology.

1.3 Limitations

In dam safety context the use of reliability-based methods is not well developed, as will be seen in chapter 4. Some attempts have been made, but many questions remain to be solved. Dam safety is a complex area as it includes complicated technical systems and borders politics, social science and philosophy. In some aspects the area described in this thesis may be considered too vast, but the intention has been to give background of both safety concepts and dam safety and by doing so show how structural reliability fits into dam safety. Those areas are both huge and for this reason the summaries given does not claim to be complete.

Further limitations are that only ultimate limit states of concrete dams have been considered. Failure modes resulting in global failure, where the dam loses its ability to retain water are treated, while failure modes leading to partial loss of function are not treated.

Concerning the load bearing capacity and loads, this thesis is limited to describe self-weight of concrete, shear strength of concrete to rock interface, uplift, hydrostatic water pressure and ice loads. For a complete analysis, failure of foundation is of major importance and considerably more focus on this is necessary, as indicated by Paper I.

In some cases the statistical descriptions are based on no or limited information to be able to perform a reliability analysis. This is clearly mentioned where relevant.

1.4 Research contribution

As will be seen, the work presented in this thesis is one of few in the present research area. Progress in a number of areas have been made, the most important are

- Simulations of uplift based on a geostatistical description of the hydraulic conductivity beneath the dam. In general the uplift pressure is very difficult to measure and the result is large (but unknown) uncertainties. This method gives possible statistical distribution of uplift, for input to a reliability analysis or for use in an assessment procedure, and is shown to be a powerful tool.
- Treatment of headwater level in a way suitable for reliability analysis.
- Definition of failure modes, based on literature survey. The identified failure modes are sliding along the concrete/rock interface, sliding through rock mass and adjusted overturning. These failure modes are somewhat different from those usually applied in design and assessment.
- Definition of a system of failure modes, that allows the system reliability to be estimated. Failure of a structure is considered as a series system of all failure modes. However, for e.g. sliding along the interface to occur, both sliding with bonded/partially bonded interface and sliding with an unbonded interface has to occur, which result a parallel system. The system description is novel for dams.

In addition to this, structural reliability analysis of a few dams has been performed, as is shown in Paper I and Paper II. These papers show that the method works well for dams and point out some of the most important variables.

1.5 Outline

Chapter 2 gives a summary of technical risk management in general and a discussion on tolerable risk. Dam safety risk management in general, in Sweden and in the hydropower owning company Vattenfall is described with the objective to place structural reliability of concrete dams in its right context.

In Chapter 3 different safety concepts are discussed. Focus is on structural reliability analysis, but partial factor design is also briefly described. Target safety values in design guidelines are given.

Chapter 4 describes concrete dams in general and the failure modes generally applied in concrete dam design. A literature survey on the failure modes that should form the basis for limit state functions is given and limit state functions are defined. The system of failure modes for a concrete dam is defined.

Chapter 5 is related to structural reliability of concrete dams. Target safety index is discussed and a literature survey of papers where structural reliability is applied to concrete dams is given, followed by a short summary of two partial factor design codes for concrete dams and a short discussion of the possible use of structural reliability for concrete dams in the near future.

In Chapter 6 the main resistance parameters and loads acting on concrete dams are described more in detail. The objective here is to present distribution functions for stochastic variables to be used in future re-assessment situations. The system of failure modes presented in chapter 4 is updated.

Chapter 7 summarize the appended papers

In Chapter 8 conclusions and suggestions to further research are given.

2. Risk management and dam safety risk management

In this chapter the general risk management process is briefly described in order to show how it can be, and to some extent is, used in dam safety. Approaches to derive tolerable risk are briefly discussed and a short introduction to the dam safety work in Sweden is given. The advantages of risk management in dam safety are described. In the last section the dam safety work performed at Vattenfall is described.

2.1 General risk management of technical systems

Absolute safety is neither possible nor desirable to attain, as it would be achieved only by use of infinite resources. Instead a tolerable level of *risk* must be found. Risk is the result of uncertainty; when no uncertainties are involved we can say with complete confidence what will be the outcome of a certain event and thus avoid the dangers imposed. On the other hand, as mentioned in Hansson (2002), for the uncertainty to constitute a risk something must be known about it - otherwise it will not be regarded as a risk. In many technical contexts, dam safety included, *risk* is defined as the product of *probability* of occurrence and the associated *consequence* of an unwanted event. There are several other definitions of risk but those are not discussed here. A *hazard* is a condition with the potential for an undesirable consequence, while risk describes the potential effect that hazard is likely to cause on a specific target.

Humans perform risk analyses intuitively in every day life. The use of formal risk analysis in “risky” business has been developed in areas such as human health, nuclear power, space engineering and for chemical industries. In dam safety, risk analysis is finding increasing acceptance.

Risk management is generally used for the whole process of identifying, estimating and evaluating risk, and decisions, implementation and monitoring of risk reducing measures (Ljungqvist, 2005). According to IRGC (2006) risk management can suggest alternatives for the same need so that the hazard is removed, isolate activities so that exposure is prevented or make risk targets less vulnerable to potential harm (prevent, control, mitigate). Figure 2-1 shows the general risk management process (IEC:1995, (1995), similar to that by Kemikontoret (2001), Hartford and Baecher (2004), SS-EN 1050:1996 and Kolluru (1996)).

Risk assessment has at least two different definitions. In this thesis it is defined in accordance with i.e. ICOLD (2005), Ljungqvist (2005) and Hartford & Baecher (2004) and includes *risk analysis* (estimation of likelihood of unwanted events, estimation of their consequences and the uncertainties involved) and *risk evaluation* (consideration of the tolerability of the risk), see also Figure 2-1. This is however, not the only definition of risk assessment and there are important issues of interpretation that has to be taken into account by risk managers before definition of the risk assessment process is made.

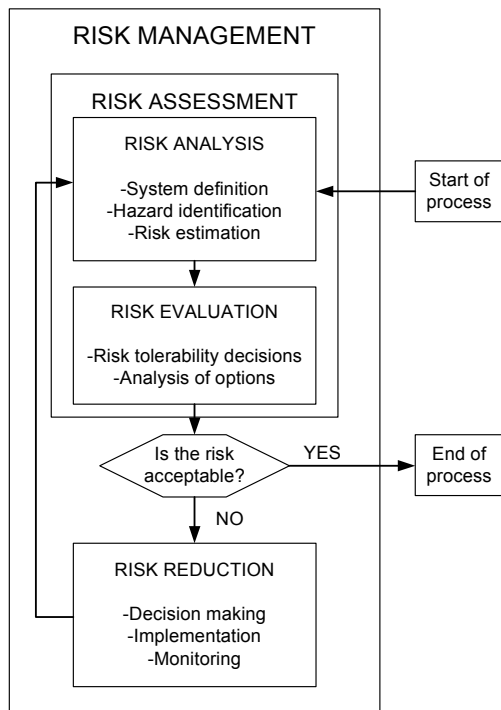


Figure 2-1 - Risk management process IEC:1995 (1995).

2.1.1 Risk analysis

The purpose of risk analysis is to describe and estimate the risks that a system poses on its environment. The fundamentals of risk analysis are to de-aggregate the system into subsystems and reveal the connections and functions in order to understand the sources and magnitude of risk.

The risk analysis process should, according to IEC:1995 (1995) and Hartford & Baecher (2004), be performed according to the following procedure (also shown in Figure 2-2):

- Scope definition
- Hazard identification and initial consequence evaluation
- Risk estimation
- Verification
- Documentation
- Analysis update

2. Risk management and dam safety risk management

The hazards should be identified together with the ways in which they could be realized. Known hazards should be stated and formal methods (as those described below) should be used to identify potential hazards.

The hazard identification may give rise to a very large number of possible scenarios and, in such case they can be qualitatively ranked, and quantification of the risk can sometimes be limited to those hazards giving the highest level of risk (Kolluru, 1996).

The risk estimation should “examine the initiating events or circumstances, the sequence of events that are of concern, any mitigating features and the nature and frequency of the possible deleterious consequences of the identified hazards to produce a measure of the level of the risks being analysed” (IEC:1995, 1995).

The list below gives short descriptions of some methods used for hazard identification and risk estimation. More information is found in e.g. Hartford & Baecher (2004), Berntsson (2001), Melchers (1999), Kemikontoret (2001).

- FMEA – Failure Modes and Effect Analysis.

A type of reliability analysis used to map out effects or consequences of individual component failure on the whole system. The system is broken down to component level, failure modes of each component are identified and effects of these on the system as a whole are systematically identified. If criticality of the considerations can be included the result is an FMECA. For analysis of failure modes FTA and ETA are useful.

- ETA – Event tree analysis.

Identifies the possible outcomes, and if required their probabilities, given the occurrence of an initiating event. The basic question is “What happens if...”. ETA reveals the relationship between functioning or failure of mitigating systems and are useful for identifying events that require further analysis by e.g. FTA. Figure 2-3 shows a simple example of an analysis where an event tree branch becomes the top event of the fault tree.

- FTA – Fault tree analysis.

A logic method focusing on an undesirable event (i.e. accident or malfunction of a system), called the top event. The fault tree is a graphical model showing the combinations of events that can result in the top event. It may also include human failures.

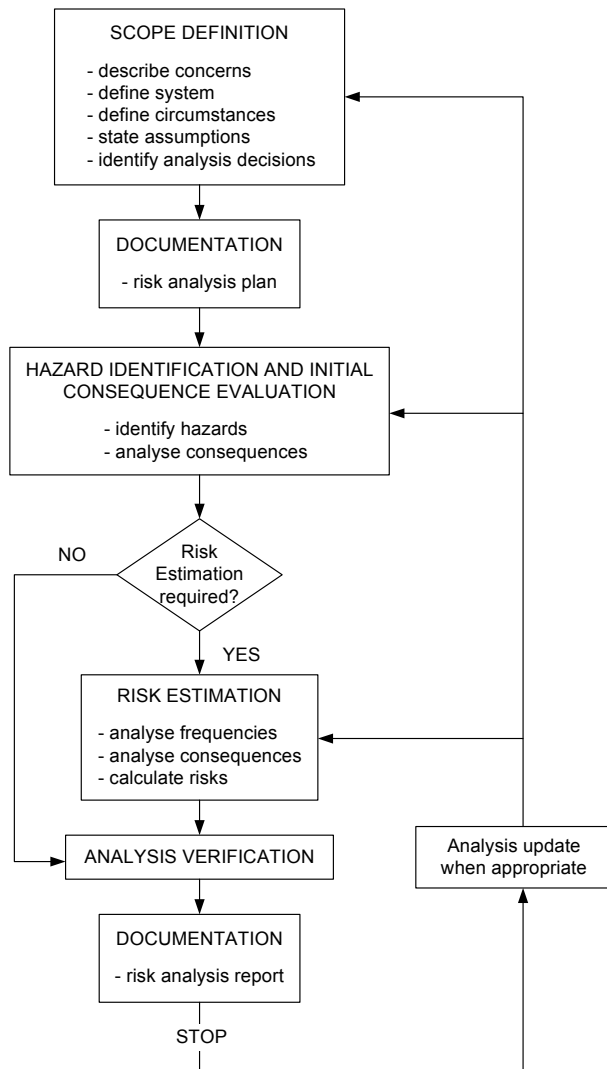


Figure 2-2 - The risk analysis process (adopted from IEC:1995, 1995).

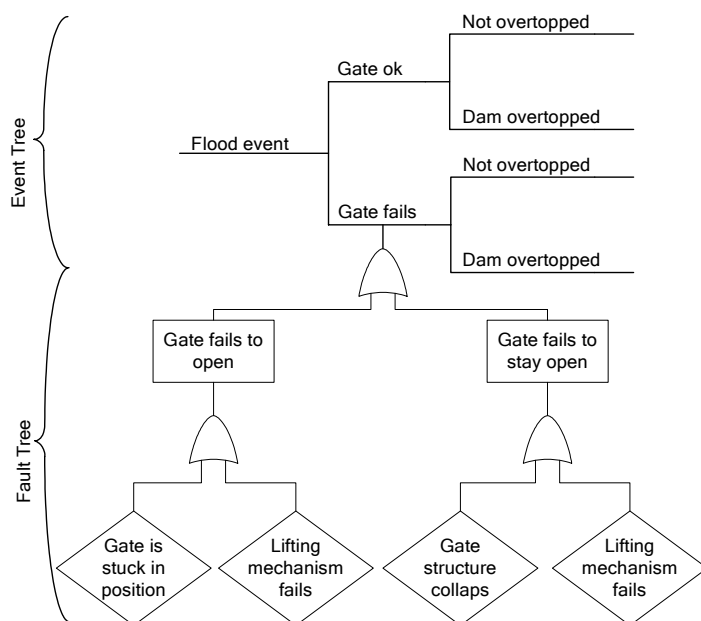


Figure 2-3 – Example of Event tree with Fault tree analysis of branch (incomplete chain).

2.1.2 Risk evaluation process

Risk evaluation is “the process of examining and judging the significance of risk” (ICOLD, 2005). In order to take decisions regarding the necessity to reduce risks, a tolerable level of risk has to be defined. The last step in the risk assessment process is to compare the risk resulting from the risk analysis with the tolerable risk from the risk evaluation process, to judge if risk reduction is necessary. The following part is important for the discussion on target safety index in chapter 3.

2.1.2.1. Tolerable risk

This section is a short summary and does not claim to be complete. The aim is to give some knowledge of the difficulties inherent in decisions of tolerability for some further discussions on tolerable levels and target safety index for dams.

The HSE (2001) carefully distinguishes between *acceptable risk*, which is the risk everyone who might be impacted is prepared to accept, and *tolerable risk*, the risk within a range that society can live with, that might not be regarded as negligible or something we might ignore, but something we need to keep under review and reduce if and when we can. IRGC (2006) add that “acceptable” refer to a situation where risks are so low that additional efforts for risk reduction are not seen as necessary.

2.1.2.1.1. *Perception of risk*

The idea of tolerable risk is rather novel and aims at protection or risk minimizing when risks are felt to be high. The way people perceive risks and apply value judgement is complex and an important basis for risk decision-making and risk evaluation criteria. Among many factors influencing or apprehension of risk can be mentioned (see e.g. Kemikontoret, 2001) :

- Degree of benefit. Larger risks are accepted if an activity is beneficial. An industry can, e.g., be accepted in one area but not in another depending on the unemployment rate and thus benefit.
- Voluntary or involuntary. Risks which we can not influence are less accepted than voluntary risks, we are willing to go skiing or mountaineering, but less willing to accept risks, orders of magnitude smaller, from e.g. industries near our home.
- Potential of societal catastrophe. Relatively frequent small accidents are more easily accepted than one single rare accident with large consequences, even if the total number of casualties in the small accidents is equal or greater. This phenomenon is called risk aversion.
- Possibility to control. If the person bearing a risk also controls the risk, it will be more easily accepted than if someone else is in control of the risk.
- Known or unknown sources. Unknown sources are less accepted. New technology is often treated more strictly than already established technology.

Historically, protective measures were not taken until the hazard had shown its consequences. Vrijling et al. (1998) points out that the public and political opinion of risk is to a large extent influenced by sudden and spectacular accidents (e.g. the Chernobyl catastrophe), and then not only by the accident itself but also by the attention paid to it by media and politicians.

2.1.2.1.2. *Principles and approaches to address tolerable risk*

As pointed out in Vrouwenvelder et al. (2001) (a summary of a larger study by working group 32 within CIB) it is not the engineer who makes the decision about acceptance of risk from civil engineering activities, but politicians. They are, in turn, influenced by e.g. media, public opinion and lobby groups. Vrijling et al. (1998) argue that decisions of acceptable risk should, in a modern and highly technological society, be based not only on historical and subjective ideas but on outcome of risk analysis and probabilistic computations based on an objective set of rules. Ramsberg (2000) points out that current societal decision-making about risk is most likely wasting resources and that potential gains from reducing the irrationality and arbitrariness are very large.

Hansson (2002), on the other hand, writes “the risk issues of different social sectors always have important aspects that connect them to other issues in these respective sectors. The technocratic dream, with its unified calculation for all social sectors, is insensitive to the concerns and the decision procedures of the various social sectors”.

2. Risk management and dam safety risk management

IRGC (2006) is of the opinion that for society to make prudent choices about risks the scientific process (in risk assessment) should include both the natural/technical and social sciences, including economics. The process should be that, first, technical scientists produce the best estimate of the physical harm that a risk source induce and, secondly social scientists and economists identify and analyse the issues that individuals or society as a whole link with a certain risk.

As summarised by ICOLD (2005) the top principles to find a tolerable level of risk, from which sub-ordinate principles and the associated tolerability of risk criteria are derived, are:

- Equity – the right of individuals and society to be protected, and the right that the interests of all are treated with fairness;
- Efficiency – the need for society to distribute and use available resources so as to achieve the greatest benefit.

According to Vrouwenvelder et al. (2001) acceptance limits originate from three different angles:

- Individual acceptable level of risk.
- Societal acceptable level of risk.
- Economic criteria

Individual acceptable level

The individual concern (HSE, 2001) is that of how a risk affects individuals, their family and things they value.

The tolerable level for individual risk can be derived from comparison with the overall risk of dying (this is approximately 10^{-3} /year for people below 60 years in developed countries and 10^{-4} for girls 10-14 years, who have the lowest death rate) and can be approximated by

$$P(\text{casualty}) < \xi \cdot 10^{-4} \quad (2.1)$$

where ξ depends on the voluntariness and profit. Involuntary risks of little benefit result in low ξ of 0.01-0.1 (Vrouwenvelder et al., 2001).

On individual level, Vrijling et al. (1998) note a tolerance of 1000 times greater risks for voluntary than for involuntary activities with the same benefit.

Paté-Cornell (1994) discuss a set of safety goals for industrial risk management strategy. There is an upper bound above which risk to an individual is unacceptable and has to be reduced or eliminated regardless of the costs. There is also a *de minimis* risk level which is so low as to be “below legal concerns”, because the benefits or risk reduction are so small as to be negligible to the individual. The *de minimis* is 10^{-7} - 10^{-8} /yr for members of the public, and 10^{-6} /yr for workers, while the upper bound for unacceptable individual risks is 10^{-5} - 10^{-6} /yr for members of the public, and 10^{-3} - 10^{-4} /yr for workers. Between the upper and lower threshold, risk reduction measures should be

adopted if they are cost effective (e.g. using the two million dollars per life criterion where a 10^{-4} /yr risk is eliminated if it costs less than US\$ 200 per person, a 10^{-5} /yr risk if its costs less than US\$ 20 and a 10^{-6} /yr risk if its costs less than US\$ 2).

Societal acceptable level of risk

Unlike the individual risk tolerability, where the risk is weighted against direct and indirect personal benefits, the societal risk tolerability must consider risk-benefit trade-off for the whole population. In the individual sphere, decisions can be amended if risks exceed the expected benefit, but in the societal sphere individuals can only choose their own risk acceptability to a limited extent. From the societal point of view the total damage in terms of casualties, material, environmental and economic damage must be considered. On a national level it is also important that the total risk is acceptable, implying that for a large number of locations of a hazardous activity the acceptable probability of accidents for each of the locations is lower than in a case of few locations (Vrijling et al., 1998).

The societal risk is often presented by F-N curves as that shown in Figure 2-4. The requirement is $P(N_d > n) < A \cdot n^{-k}$, where N_d is the number of people being killed in one year in one accident, A ranges from 0.001-1/year and k is from 1 to 2. High values of k express the social aversion to large disasters.

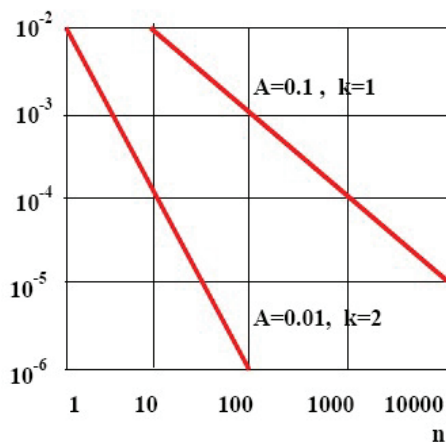


Figure 2-4 - FN-curve, from Vrowenvelder et al. (2001). The upper line may be considered unacceptable and the lower negligible. Between those limits ALARP principles may be adopted (discussed later).

Economic criteria

Vrijling et al. (2000) are convinced that the acceptance of risk can only be understood in a cost-benefit framework in the widest sense, where personal and national gain, capital and running costs, damage to environment as well as the risk play a part in the weighing process. A regulation where no attention is given to benefits of the activity is useless, as

the weighting process between alternatives then become distorted. The risk of a large hydropower dam and the damage it does to the environment (in the building and operation phase or in case of failure) cannot be discussed apart from the benefit it brings to the national and local economy.

There are different descriptions on how an economic criteria should be formulated, but should include investments (and net capitalised profits), direct and indirect costs of failure (direct damage, cost of repair, future failure costs of the repaired structure), as well as probability of failure (Vrouwenvelder et al., 2001, JCSS, 2001, Vrijling et al., 1998). Difficulties are to determine the cost of failure, where, in some approaches, the value of a human life has to be defined. This can be defined in a number of ways; the net national product per inhabitant, the amount of money the individual would earn, one's value to oneself etc. Vatn (1998).

Vrijling et al. (1998) suggest the economically optimal level of safety given as

$$\min(Q) = \min(I(P_f) + PV(P_f \cdot S)) \quad (2.2)$$

where Q is the total cost, I is the investment, PV is the present value, S is the total damage and if human life is involved the amount of damage is increased to $P_{df_i} \cdot N_{pi} \cdot s + S$

where P_{df_i} is the probability of being killed in case of the event, N_{pi} is the number of participants in activity i and s is the value of a human life.

One point to be made here is that, even though this approach is conceptually possible, it is not so easily applied and, above all, it is a matter of society (government) to decide which approach is to be used and, in case of this approach to be chosen, to put a value on human lives.

2.1.2.1.3. ALARP

The "As Low As Reasonably Practicable" (ALARP) principle states that only if further risk reduction measures (in time, money, etc) are GROSSLY disproportional to the risk reduction achieved, it is considered to be unreasonable (HSE, 2001, Ale, 2005). The ALARP principle is applied in the UK, where it is a matter for court to decide if the ALARP principle has been followed, and thus it can only be judged whether or not the ALARP demonstration is acceptable after the consequences has been incurred.

With reference to Figure 2-4, it can be said that if risks fall above the upper line risks are unacceptable, and below the lower line they are acceptable (no risk reduction needed). Between those lines the ALARP principle is valid.

Whether or not the ALARP principle should be applied is a governmental decision, or perhaps, if not prescribed by government, that of a company (for use within the company) to go beyond minimum legal requirements.

Unlike the UK, where the ALARP principle is applied and "everything that is not explicitly allowed is forbidden, unless it can be justified, where necessary in court", the Netherlands has (according to ICOLD, 2005) the only known example of legislatively

approved risk criteria. In the Netherlands “everything that is not explicitly forbidden is allowed” and risk reductions are weighted against risk in a much finer balancing act (Ale, 2005). In the Netherlands the onus is on the duty holder to get the risk modelling and numerical elements of analysis right and quantify the risk acceptability, and the political judgements are built into the risk acceptability criteria. Surety is provided by getting the numbers right (Hartford, 2006). In the UK acceptable risk is defined in terms of “not un-acceptable”, “not reducible”, and “worth taking”.

2.1.2.1.4. Tolerable risk in Sweden

Räddningsverket (1997) mention that several European countries have criteria for what is considered a tolerable risk. Risk analysis where tolerable risks are needed as input are increasingly used in Sweden as well, but common criteria or guidelines does not exist.

2.1.3 Risk reduction

When the risk analysis has resulted in an estimate of risk and the risk evaluation has given tolerable levels it is up to managers to decide if risk reduction is necessary. If the ALARP principle is applied, risk reduction when risks fall in the “ALARP-area” (between unacceptable and acceptable) has to be decided upon.

Risk treatment, according to ICOLD (2005), can be grouped into the categories:

- Avoid the risk. Do not build the facility or decommission the existing one.
- Reduce the probability of occurrence by rebuilding, upgrading, applying operational restrictions, education, changes in management procedures, increased redundancy, monitoring/surveillance/inspections
- Reduce the consequences by such as emergency planning, restrictions to accessibility, and relocation of exposed population at risk.
- Transfer the risk, i.e. sell the facility
- Retain the risk, i.e. tolerate or accept the residual risk.

The first three would actually reduce the risk, while the last two would not. Transferring the risk reduces the risk for the owner, but not for society. Even when risk reduction activities have been carried out, residual risks remain and the last option may apply.

No further discussion on this matter is given here.

2.2 Dam Safety in Sweden

In 1990 the Swedish Committee for Design Flood Determination published their Guidelines on flood determination (Flödeskommitténs riktlinjer, 1990) and a revised version was issued in 2007. Design flood determination is based on the potential consequences of dam failure during flood conditions and classified into Flood Design Category I (for dams where failure could cause loss of life or personal injury, considerable damage to infrastructure, property or environment, or large economic damage) and Flood Design Category II (where failure can only cause damage to

2. Risk management and dam safety risk management

infrastructure, property or environment). Dams causing only damage to the owner are not included. For Flood Design Class I the design flood is simulated by hydrological modelling techniques that describe the effects of extreme precipitation under particularly unfavourable hydrological conditions. For Class II a frequency analysis is applied. More information of the procedure of design flood determination is given in section 4.5.

The result after issuing these guidelines was that design floods were increased for many high consequence dams compared to the available discharge capacity, as was expected due to increased safety demands, necessitating measures to be taken. In preparation for the process of increasing dam safety, and to pinpoint problem areas, several studies were started by the power industry and resulted in 26 reports (the VASO-reports), e.g. on the ability to withstand water levels above the retention level and practically available spillway capacity.

For each river a common solution for all dams, in cooperation by all involved dam owners, was derived. The solutions applied included

- Use of larger reservoirs for retention of water. For these reservoirs the water is allowed to rise above retention water level, delaying and reducing the flood in the downstream area. The result is that downstream dams do not need rebuilding or that less rebuilding is necessary.
- Increased discharge capacity by rebuilding or modification of spillways
- Increased discharge capacity by temporarily allowing increased water levels, sometimes requiring stability increasing measures and/or heightening of crests and cores.

Projects to upgrade or rebuild dams for the new design floods should also give a result that fulfils modern criteria in other respects and, in general, other modification and rebuilding is performed simultaneously to the design flood modifications. The upgrading work is still on going.

According to Mill (2008) the Swedish model for dam safety can be separated into three parts:

- Demands by society expressed in comprehensive and general rules in Miljöbalken (the Environmental Act). Each dam owner has strict responsibility for all consequences resulting from a dam failure, meaning that the owner is liable to pay compensation (except in the case of war actions).
- RIDAS (2008), see explanation below.
- Supervision by authorities (Svenska Kraftnät and the County Administrative Boards (Länsstyrelserna)). This task will be developed to support dam owners ability to take their responsibility.

RIDAS is the Swedish Guidelines for Dam Safety (Kraftföretagens riktlinjer för dammsäkerhet), and the first edition was accepted 1997. The guidelines shall not be

considered as law or directions but Swedish dam owners who are members of the SwedEnergy (Svensk Energi) are committed to follow the guidelines.

The overall objectives of the guidelines are to

- Define requirements and give guidance to sufficient and uniform dam safety
- Form a basis for uniform assessment of dam safety and for identification of upgrading needs due to dam safety issues
- Support governmental dam safety supervision.

RIDAS is formulated as two parts; *guidelines* and *application guideline*, where the application guideline gives detailed information and guidance on how to use the guidelines in practice.

The level of dam safety prescribed in RIDAS shall be achieved. Since the guidelines does not have the binding status of a law, and their purpose is to provide objective support for dam safety work, deviations from the guideline are allowed if the same or higher dam safety is achieved, as long as motives and documentation is clear and RIDAS can be said to specify the minimum safety level (RIDAS, 2008, Berntsson, 2001). Dam safety shall be carried on with good quality in planning, design, building, operation, monitoring, maintenance and emergency preparedness.

One of the most important fundamentals in RIDAS is the *consequence classification*, where dams are classified according to the consequences if dam failure should occur. The consequences (more specific, the incremental consequences, i.e. the incremental impacts which would not have occurred under the same natural conditions (e.g. flood)) are evaluated in terms of probability for loss of human lives and probability of damage on environment, infrastructure and other economic values as shown in Table 2-1. Safety requirements are differentiated, with higher demands for higher consequence classes (the highest class is 1A and the lowest 3).

2. Risk management and dam safety risk management

Table 2-1– Consequence classes according to RIDAS (2008).

Consequence class	Consequence of a postulated dam-breach
1A	High probability of loss of many human lives or high probability for very serious damage on - important urban infrastructure - considerable environmental values or very large economic damage
1B	Probability of loss of human lives or serious personal injury is not negligible or noteworthy probability of damage on/to - important urban infrastructure - considerable environmental values or high probability of large economic damage
2	not negligible probability of noteworthy damage to - urban infrastructure - environmental values or economic damage
3	

According to RIDAS a dam owner shall perform dam safety inspections and reviews at the following levels and intervals:

Table 2-2 – Intervals of dam safety review according to RIDAS (2008).

Dam safety review	1A	1B	2
Operational inspections	Continuously	Continuously	Continuously
Dam monitoring	Continuously	Continuously	Continuously
Inspection	2/year	2/year	1/year
3-year inspection	1/3 years	1/3 years	1/6 years
Periodic Dam Safety Review (FDU)	1/15 years	1/24 years	1/30 years

In the Periodic Dam Safety Review a comprehensive and systematic analysis and valuation of the safety of the dam, based on a complete analysis of the whole system, is performed.

During all types of dam safety inspections and reviews, deviations from required or desired level of performance are noted. These have to be taken care of so that the dam fulfils required safety. For an owner of a large dam portfolio the dam safety work has to include some kind of prioritization of remediation works to use available resources in

the best way possible. This prioritization can be designed in different ways and is at present under development by some of the Swedish dam owners.

During the period from 2000 to present times, dams are redesigned and upgraded or rebuilt for the new design floods and also in other RIDAS aspects. The process of determining design floods for dams and the process of upgrading/rebuilding is quite complicated and the rebuilding/upgrading process will continue many more years.

2.2.1 Dam safety today

At present the majority of dams with insufficient discharge capacity have been rebuilt or upgraded for the new guidelines and focus is shifting to other areas such as (Cederström, 2009):

- Risk management/Risk analysis. Bench-mark studies have been performed and risk analysis is becoming increasingly used.
- System perspective on risks. This has been described earlier as fundamental in risk management. One area, currently under consideration, is gated discharge facilities where mechanical, electrical and structural issues are closely related and where the system perspective is necessary.
- Monitoring and surveillance. Historically this area was not well-developed in Sweden but recent research has come up with several new methods and these together with traditional methods and monitoring equipment are/will be installed and used for continuous or periodic surveillance. This is ongoing.
- PTO – People Technology Organisation. Dam safety operation, especially during complex situations, is influenced by uncertainties in human behaviour. Complex organization, instructions and/or technology can become critical during those conditions.
- Emergency preparedness. One of the areas addressed in the VASO-reports. A pilot project by the power industry in cooperation with the authorities involved to improve the emergency preparedness plans was completed in 2006 and since then the same has been started for a few rivers. New techniques with digital maps are being increasingly used. A pilot project on warning systems are ongoing.
- Ensuring human resources/competence. SVC (Swedish Hydropower Centre) is financing a number of PhD-projects and part-time Professors to strengthen the development in different areas concerning hydropower. Cooperation in ICOLD, DSIG (Dam Safety Interest Group) etc are also important for international exchange.
- Security and Public safety. Good security is necessary for dam safety and public safety concerns life and safety of the public and coincides with dam safety.

- Floating debris that may become a problem for the spillway function in case of (large) floods. An international project is to be reported in 2010.

From a general point of view it is also important to notice the gradual shift from analysis of details to systems analysis.

2.2.2 Comments

As the dam owner is strictly responsible, the government and authorities does not specify any target safety for dams. Instead it is up to the owners to decide what is safe enough, and RIDAS is used as guidance. Ultimately, however, it is up to each company to decide if further risk reduction should be applied, and if e.g. the ALARP principle is to be used.

2.3 Risk management in Dam Safety

Dams are used for e.g. water irrigation and energy production all over the world. Their contribution to economic and societal development and welfare is substantial. At the same time dams is a potential threat to the society due to the remote, but still real, possibility that a dam might fail. A dam failure could have huge impacts; considerable numbers of people could lose their lives, most of the property in the threatened area would be damaged, heritage and works of art could vanish and the environment would be threatened directly by the water and indirectly by the release of toxic substances from installations damaged by the flood waters (ICOLD, 2005). Dam engineers have known of this since the first dams were built and dam safety is a very important area. As pointed out in (ICOLD, 1987) even a smaller dam failure resulting only in operational loss will have serious economic consequences.

In ICOLD (1987) a safe dam is defined as “a dam with appropriate reserves, taking into account all reasonably imaginable scenarios of normal utilization and exceptional hazard which it may have to withstand during its life”. In RIDAS (2008) the concept dam safety refers to “safety towards emergence of uncontrolled discharge of water from the reservoir, which might cause damages in the vicinity or downstream area of the dam. It is also a conception of a qualified, interdisciplinary activity aiming at reducing the probability of accidents and minimizing their effects”.

During the history of dams, risks have been considered and taken care of, but by an engineering standards-based approach using large safety factors, conservatism and engineering judgement.

Figure 2-5 shows an example of the risk decision framework. Typically civil engineering activities fall into the upper part (A); codes and standards are extensively used and deal with most uncertainties, good practice and engineering judgement supplements where necessary. The risk analysis is thus made implicitly. In more complex situations risk-based analysis is used.

Dam safety decision-making, on the other hand, falls into the mid part. This is since in dam safety, codes and standards are not as well-developed and used and consequently decisions have to large extent been based on good practice and engineering judgement.

Decisions based on risk analysis or assessment is now becoming increasingly used. In cases where uncertainties or economic implications are large, decisions may even be dominated by company or societal values (Hartford & Baecher, 2004). The result is that decisions in dam safety are to larger extent than in other civil engineering activities influenced by the complex risk apprehension and acceptance of the public.

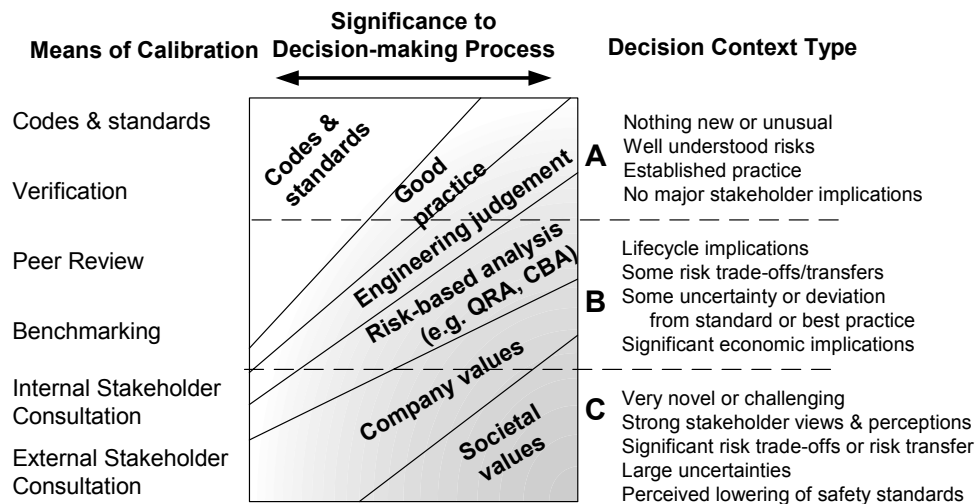


Figure 2-5 - Risk decision framework (from Hartford & Baecher, 2004, referring to UK Offshore Association, Brinded, 2000).

The use of risk analysis and assessment in dam engineering is still in its infancy, but becoming increasingly used worldwide. As pointed out by ICOLD (2005) uncertainties are all-present in dam design, but dealing with uncertainty is such an intrinsic part of work that managers and designers do not give this conscious consideration and overlook the fact that the main part of their work is risk management. This means that risk analysis is, and has been, performed at all times, but that this is often not performed in the structured and reflective way described in the preceding sections.

The application of risk analysis in dam safety management is, among other things used to (ICOLD, 2005):

- Determine the consequence category of a dam,
- Assist in developing more effective surveillance processes,
- Improve conventional dam safety assessment processes,
- Demonstrate a sound understanding of the sources of risk and their relative contributions,
- Determine resource requirements for investigations,

2. Risk management and dam safety risk management

- Determine how analysis and surveillance should be allocated to a particular dam,
- Prioritise dam safety modifications and improvements across a portfolio of dams,
- Communicate dam safety recommendations and/or decisions to financial planners, senior management, regulatory bodies and the public.

It has been mentioned already, but the importance of considering the whole system when performing the risk analysis must not be underestimated. When analysing a particular dam this usually means that the whole river system has to be seen as the system, as shown in Figure 2-6.

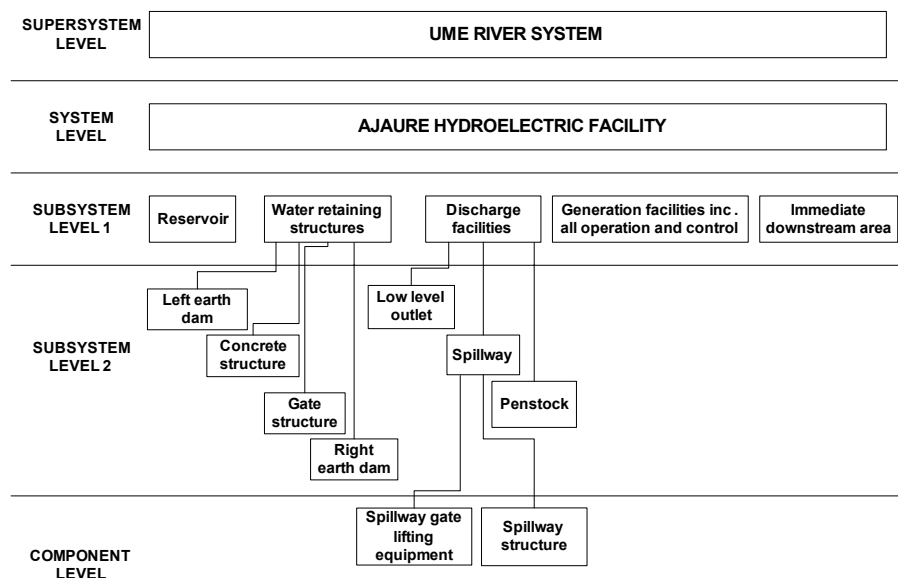


Figure 2-6 – Example of a block diagram (Vattenfall AB, 2000. By courtesy of Vattenfall).

The limitations of risk assessment for dams are among others the difficulty to reliably quantify the probability of failure, the difficulty to estimate the consequences of dam failure, the lack of widely recognised and accepted methodology for determining tolerable risks and the lack of acceptance in society of the concept of tolerable risk (ICOLD, 2005).

Risk reduction includes activities such as ensuring the structural integrity of the dams for all possible events, that operation of the dam does not endanger it in any way and that the operational personnel can deal with all possible situations, ensuring that discharge capacity is sufficient for design floods etc. Consequence reduction includes activities such as early warning and emergency preparedness plans, cooperation with

rescue corps, etc. All of these activities include uncertainty, sometimes to great extent, which make it difficult to know when safety is sufficient and when it is not.

2.4 Dam safety at Vattenfall

During the years 2002-2007 Vattenfall was upgrading and rebuilding approximately 40 dams to withstand floods with return period of about 10 000 years (flood calculation according to Flödeskommitténs riktlinjer). All the dams were designed for larger amount of water and the purpose is to increase the safety. In some cases dams were rebuilt to increase the discharge capacity and in others the height of the dam crests was increased to withstand larger water levels. Some dams were improved in both aspects. In addition, measures to improve e.g. stability and erosion protection were taken. During the years 2007-2014 this work is continued and other dam safety problems are also addressed.

2.4.1 Risk management process

The dam safety work at Vattenfall is risk based. The Dam Safety Management Process at used Vattenfall is shown in Figure 2-7 and follows the ideas of ICOLD (2005), Hartford & Baecher (2004) and others, previously defined. The aim of risk management is to collect all questions related to dam safety and ensure that no important questions are forgotten. The three main parts are

- *Operation and Maintenance* - the normal operation of the facilities, the maintenance of emergency preparedness plans, the on-going monitoring and surveillance, and other basic maintenance work that is carried out at the facilities.
- *Overall Risk Management* – overall planning, prioritization of measures to be taken, follow-up, etc in order to have good and uniform dam safety.
- *Risk Management in Depth for a Particular Dam* – when simple measures are not adequate to correct deficiencies of a dam, a number of possible measures can be taken, and to choose the right action an in-depth risk management/analysis is performed for the specific dam.

In Figure 2-7 the diamond boxes are the risk assessment, as shown in Figure 2-8. The systematic risk assessment described previously has been used in a number of studies and will be further developed and used as standard procedure, especially concerning the in depth risk management of a particular dam.

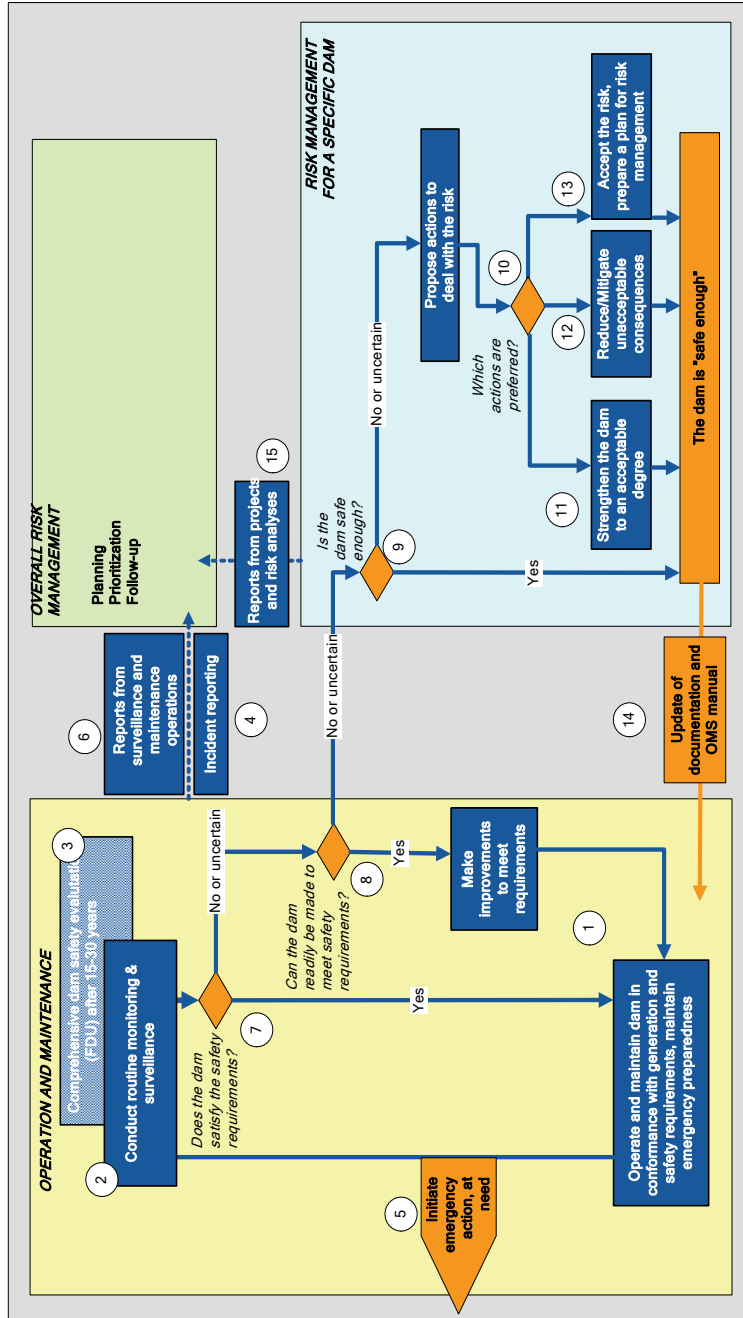


Figure 2-7 - Dam safety risk management process (Brandestien & Meyer, 2008, by courtesy of Vattenfall.)

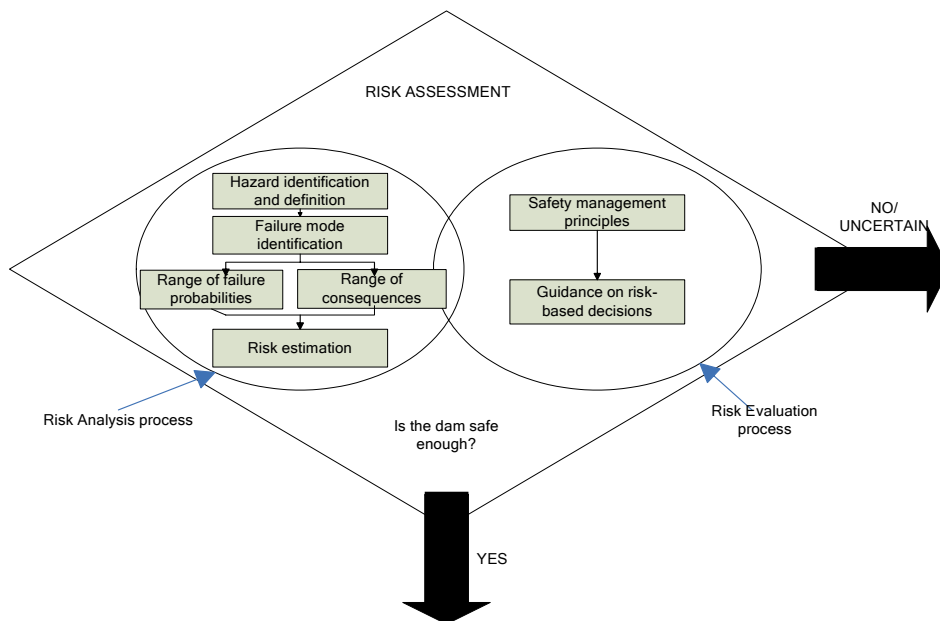


Figure 2-8 - Risk assessment (ICOLD, 2005).

To achieve a good safety level throughout the entire dam portfolio, and focus resources on the dams where it is most urgent, a prioritisation system for known deficiencies is necessary. This is a vital part of the overall risk management and one of the major challenges at the time being is to develop this system to become fully operational.

2.4.1.1. Deficiencies and valuation

Deviations from specified level or function of features are divided into three groups; *physical deficiencies of the dam*, *deficiency in dam surveillance* and *deficiency in management, surveillance methods or working routines*. All of these are serious for dam safety. Deficiencies are found by inspections or monitoring.

Physical deficiencies are divided into reported and potential deficiencies. Examples on physical deficiencies are ability to retain or discharge water, e.g. leakage through a dam or insufficient discharge capacity. Each identified deviation is analysed with respect to dam safety, based on four aspects linked together according to Figure 2-9 to give the *vulnerability index*. All criteria are represented by numbers between 1 and 5. The reason for the 1-5 scale is that deficiencies identified at the earlier Dam safety reviews (FDU) were given numbers from 1-5, which meant that already existing valuations was possible to use without re-work. The 1-5 rating is just a relative measure of safety and may be substituted by probabilities in the future. In the vulnerability index, rating 5 represents the most unfavourable event; large magnitude of deficiency, high criticality

2. Risk management and dam safety risk management

etc., and rating 1 represents the case of no magnitude of deficiency etc. The total vulnerability thus varies between 1 and 625. The aspects taken to consideration are:

- *Magnitude of the deficiency (M)* between performance capacity and desired capacity of the feature of interest, meaning that the capacity is compared to the capacity of a feature considered to be “safe” or “sufficient”. Here rating 1 is behaviour as desired and rating 5 complete or nearly complete loss of desired function. This is further described below.
- *Criticality of component or system (C)* of the feature. Rating 1 is a component with redundancy or a component not critical to the system while rating 5 is no redundancy of a critical component. In dam safety aspects many features are critical, e.g. gates and dams, as there exist no redundancy, resulting in 100% criticality.
- *Inability to detect and respond to deficiency (I)*. The ability to, in an emergency situation, detect and arrest the deficiency before it develops and leads to dangerous situations. When no measures are in place to prevent failure (interrupt started failure sequence) or mitigate the effects the “inability” is 100 %. Rating 1 corresponds to ability to detect and arrest while rating 5 means that no reliable method to detect and arrest the failure sequence is available.
- *Frequency of loading (F)*. Rating 1 corresponds to a loading frequency of approximately 1/1000 to 1/10000 years, while rating 5 is once or several times per year.

For each consequence class a *consequence index* is assigned. Combining the *vulnerability index* with the *consequence index* gives the *risk index*.

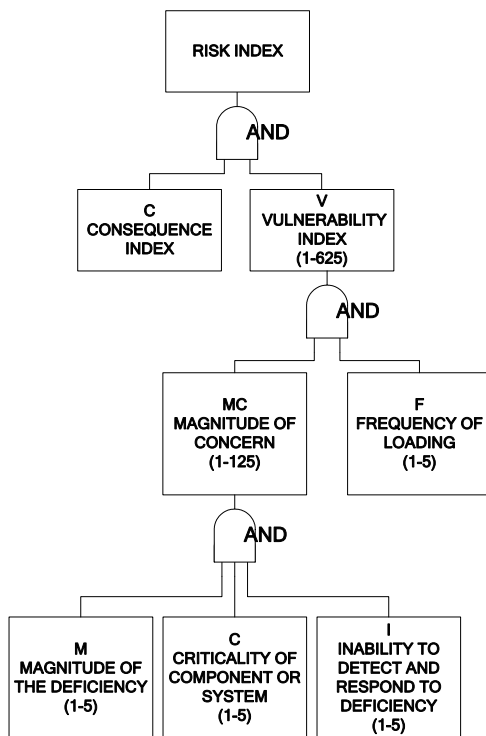


Figure 2-9 - Logic structure of risk index. (Brandesten & Meyer, 2008, courtesy of Vattenfall)

2.4.1.1.1. Magnitude of deficiency

The magnitude of deficiency can be illustrated as shown in Figure 2-10. The capacity can be described as a random variable due to inherent uncertainties in resisting factors, uncertainties in actual discharge capacity etc, and the demand can be described as a random variable due to uncertainties in loads, size of design flood etc. When the capacity is less than the demand, a deficiency exists.

Putting a rating on M is difficult and development is ongoing. A proposal on how to evaluate “magnitude of the deficiency” for stability of dams could be according to the following, where sf is the factor of safety. Other limits may be appropriate.

$sf > 1.5$	→ $M = 1$
$1.3 < sf < 1.5$	→ $M = 2$
$1.15 < sf < 1.3$	→ $M = 3$
$1.0 < sf < 1.15$	→ $M = 4$
$sf \leq 1.0$	→ $M = 5$

M could also be given a probabilistic interpretation and structural reliability analysis could be used to estimate it.

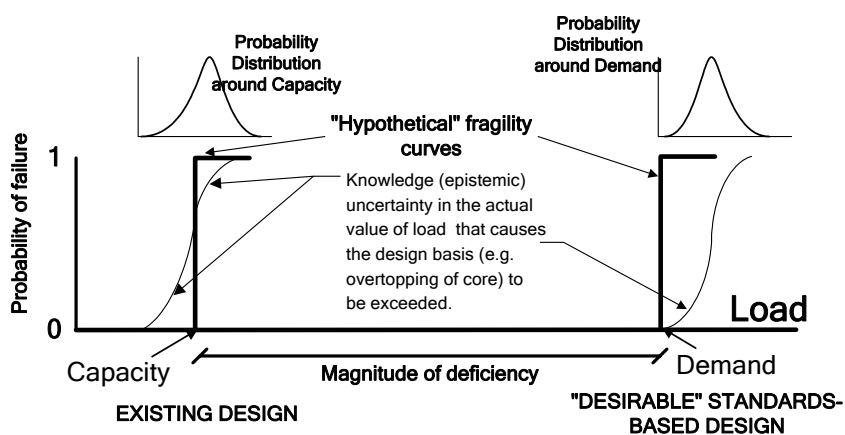


Figure 2-10 - Magnitude of deficiency (Vattenfall AB, 2006, by courtesy of Vattenfall).

2.4.1.2. Prioritisation or risk reduction measures

Risk and vulnerability indices are useful tools to describe present status of deficiencies for a dam, plant, river system, or dam portfolio, and for follow-up on changes. It can also be used for prioritisation of strengthening measures, as dams with higher risk index should preferably be attended to before dams with lower risk index.

In future applications the actual risk index is also to be compared to allowed risk index to make decisions of rehabilitation and reinforcement. A hypothetical example of vulnerability index plotted versus consequence index is shown in Figure 2-11 Here the facilities in the upper right corner has the largest vulnerability and consequence and should therefore be attended to first. Consequences are often difficult to reduce and therefore the total risk is reduced by reduction of the vulnerability index. By back-tracing the vulnerability index-input, the largest contributors to the total vulnerability can be identified and attended to.

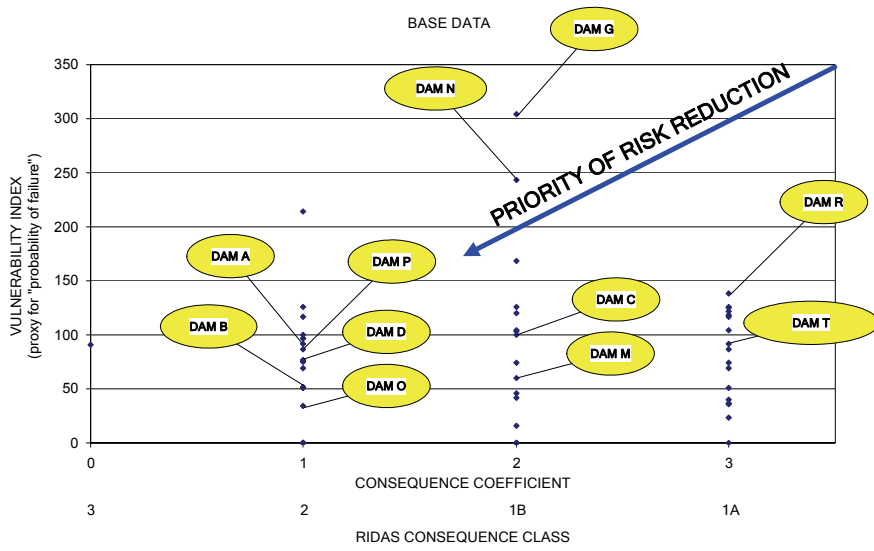


Figure 2-11 - Prioritisation of risk reduction based on vulnerability index and consequence coefficient, (Vattenfall AB, 2006, by courtesy of Vattenfall).

3. Safety concepts

The traditional method to define structural safety is through a *factor of safety*, sf , where the resistance R and the action S shall fulfil the following requirement:

$$S \leq \frac{R}{sf} \quad (3.1)$$

The factor of safety is selected on the basis of experimental observations, past experience, economical and political considerations and should be large enough to provide sufficient safety towards the unwanted event that is assumed to occur if

$$S \geq R.$$

The *partial factor method* is a development of the factor of safety implying that the permissible actions (or required resistance) shall fulfil the relation

$$\frac{R}{\gamma_R} \geq \gamma_{Di} \cdot S_{Di} + \gamma_{Li} \cdot S_{Li} + \dots \quad (3.2)$$

where R is the resistance, S_{Di} are the dead loads, S_{Li} the live loads and $\gamma_R, \gamma_{Di}, \gamma_{Li}$ partial factors. Actions with high variability can with this format be given greater partial factors than those with low variability, and thus allows for better representation of the uncertainties associated with actions and resistance (Melchers, 1999). Calibration of partial factors will be briefly discussed in section 3.5.1.

In structural reliability analysis, verification that the structure does not exceed a specified limit state is performed. This requires an analytical model describing the limit state and the model must include all the relevant basic variables. Basic variables are:

- Actions
- Material parameters
- Geometrical parameters

This thesis deals mainly with the structural reliability analysis described below, but the connection between the different safety concepts will be further described later (in chapter 3.5). There is substantial literature on structural reliability analysis, see e.g. Ang & Tang (1975), Melchers (1999), Thoft-Christensen & Baker (1982) and Schneider (1997).

3.1 Uncertainty modelling

Generally several different types of uncertainties exist (Melchers, 1999)

- *Phenomenological uncertainty*: the possible behaviour of a structure, during construction, service or extreme conditions, is uncertain

-
- *Decision uncertainty*: relates to the uncertain decision as to whether a phenomena has occurred, e.g. if limit state violation has occurred.
 - *Modelling uncertainty*: relates to the difference between the "real" behaviour and that anticipated by the used model. This is further discussed below.
 - *Prediction uncertainty*: uncertainty in the prediction of the state of a structure in the future. Can be reduced by more knowledge.
 - *Physical uncertainty*: inherent random nature of a basic variable. May be reduced by increased quality control, but can generally not be eliminated. May be described as a probability density function with associated parameters.
 - *Statistical uncertainty*: Observations of a variable does not represent it perfectly and different sample sets will produce different statistical estimators. Uncertainty due to a limited number of observations, neglecting systematic variations and possible correlations are also included. This uncertainty may be modelled by letting the parameters describing the probability density function (PDF) of a physical uncertainty be themselves random variables or by reporting different reliability values depending on PDF (sensitivity). This uncertainty may be reduced by a greater amount of data.
 - *Uncertainties due to human factors*: human errors and human intervention. Human errors are involved in the majority of cases of recorded failure. Some of these errors may be reduced by better procedures and knowledge. Modelling the uncertainty is possible for some human errors, but not for gross errors.

In this thesis the phenomenological and decision types of uncertainties are discussed to some extent (sections 4.3). Most attention is given to the physical uncertainties (chapter 6) and statistical uncertainties are implicitly included in this part. Prediction uncertainties and uncertainties due to human factors are not treated.

It is also common to distinguish between aleatory and epistemic uncertainty. Aleatory uncertainty is the intrinsic randomness of a phenomenon, while epistemic uncertainty is caused by lack of knowledge. This means that the aleatory uncertainty can not be reduced, while the epistemic is reduced by increased knowledge. In the above it is most likely that the phenomenological uncertainty, decision uncertainty, modelling uncertainty, prediction uncertainty and statistical uncertainty are epistemic, while the physical uncertainty is aleatory. The uncertainties related to human factors may be both epistemic and aleatory to different extent. It is, however, not easy to distinguish between aleatory and epistemic uncertainty.

3.1.1 Modelling uncertainty

In engineering practice, analysis is generally based on a physical understanding of the problem, but due to simplifications and approximations it is to some extent empirical (based on observations and tests) (Faber, 2001). Model uncertainty is related to the difference between the "real" behaviour and that anticipated by the model used.

The model uncertainty m may be assessed through observations according to

$$m = \frac{x_{\text{mod}}}{x_{\text{exp}}} \quad (3.3)$$

where x_{exp} is outcome of an experiment and x_{mod} is the outcome predicted by the model. According to Faber (2001) typical coefficients of variations for good models is in the order of 2-5 %, whereas for e.g. models of the shear capacity of concrete structural members it may be 10-20 %.

According to JCSS (2001) the model uncertainties may be described by

$$Y = f(X_1 \dots X_n, \theta_1 \dots \theta_n) \quad (3.4)$$

where Y is the structural performance, $f()$ the model function, X_i the basic variables and θ_i random variables containing the model uncertainties, derived from experiments. The mean of the parameters θ_i is often defined in such a way that, on average, the calculation model correctly predicts the test results.

Often model uncertainties are due to lack of knowledge and may thus be reduced by increased amount of data, or by research. In this thesis, model uncertainties are not further discussed.

3.2 Structural reliability analysis

The basis of any safety assessment is that the feasible failure mechanisms (failure modes) are identified and modelled as limit states.

For probabilistic calculations, the failure mode is described, based on a suitable model, by a limit state function

$$Z = G(\mathbf{x}) \quad (3.5)$$

where $\mathbf{x} = x_1, \dots, x_n$ are basic variables.

The basic variables should be all the parameters of importance; random variables (including the special case deterministic variables), stochastic processes or random fields (JCSS, 2001). All essential sources of uncertainties should be integrated; physical/mechanical uncertainty, statistical uncertainty and model uncertainty. It may be of advantage to separate model uncertainty from other uncertainties, such as knowledge uncertainty, but this is often difficult.

Negative values of Z correspond to “failure” and positive values to “non-failure”, and $Z = G(\mathbf{x}) = 0$ is the limit state. In n -space this equation describes a surface called the failure surface. Figure 3-1 illustrates the failure surface in 2D.

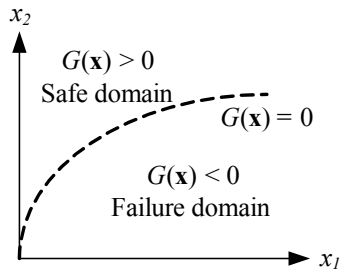


Figure 3-1– Safe domain and failure domain.

The probability of failure may be expressed as

$$p_f = P[G(\mathbf{x}) \leq 0] = \int_{g(\mathbf{x}) \leq 0} f_{\mathbf{x}}(\mathbf{x}) d\mathbf{x} \quad (3.6)$$

Where $f_{\mathbf{x}}(\mathbf{x})$ is the joint probability density function of \mathbf{x} .

The probability of failure is evaluated for a specified reference period, often, as in this thesis, the period is one year, and the statistical distributions of the basic variables should therefore be based on one year maximum values.

3.2.1 Basic reliability problem

For the basic reliability problem with only two independent variables, R = resistance and S = load, the joint distribution is shown in Figure 3-2a and equation (3.6) can be rewritten as

$$p_f = \int_{-\infty}^{\infty} F_R(x) f_S(x) dx \quad (\text{the convolution integral}) \quad (3.7)$$

where $F_R(x)$ is the probability that $R \leq x$ or the probability that the actual resistance R of the member is less than some value x . If the load effect S is in the interval $[x+dx]$, failure will occur. The probability of $x < S < x+dx$ as $dx \rightarrow 0$ is $f_S(x)$. The integral over all x gives the total failure probability. This is also shown in Figure 3-2b) where f_R and f_S are drawn on the same axis. (Melchers, 1999).

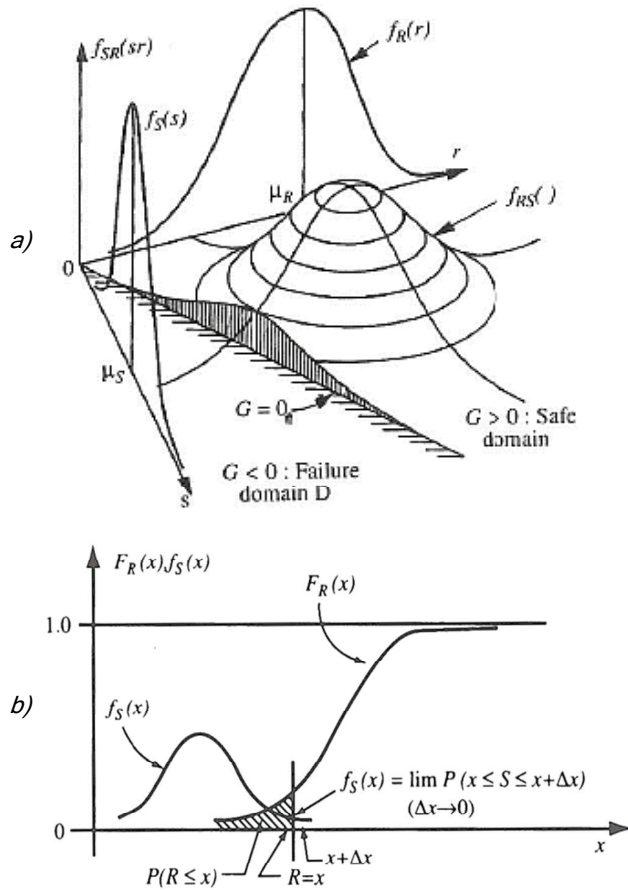


Figure 3-2 – a) Joint density function and b) basic R-S problem (from Melchers, 1999).

For independent normal random variables and linear limit state functions it is possible to make analytical integration of equation (3.7) to get the probability of failure (see e.g. Melchers, 1999), and in this case

$$p_f = P[G(\mathbf{x}) \leq 0] = \Phi\left(\frac{0 - \mu_G}{\sigma_G}\right) = \Phi(-\beta) \quad (3.8)$$

where μ_G and σ_G are the mean and standard deviation of the limit state function $G(\mathbf{x})$, Φ is the standardized normal distribution function and β is the safety index.

A low value of β thus corresponds to a large probability of failure (small margin μ_G and/or large uncertainty σ_G).

β can be seen as the number of standard deviations σ_G by which μ_G exceeds zero, as illustrated in Figure 3-3.

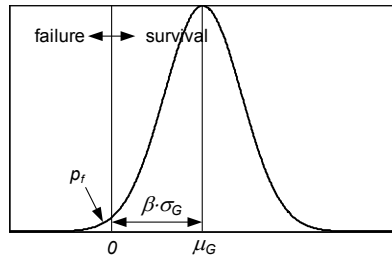


Figure 3-3 - Geometrical interpretation of β .

One problem with safety index according to (3.8) is that it is not invariant. This means that

$$G(R, S) = R - S$$

and

$$G(R, S) = \frac{R}{S} - 1$$

will not give same result, even though they are equivalent.

In general, input parameters are not independent normal variables and limit state functions are not linear. In that case it is generally not possible to solve the integral in equation (3.7) analytically. Several numerical methods exist to solve this problem as will be discussed, see also e.g. Melchers (1999) or Thoft-Christensen & Baker (1982).

3.2.2 First-Order methods

For a non-linear limit state function $G(\mathbf{x})$ a Taylor's series expansion around some point may be used to get a linearized limit state function. For normally distributed variables approximate values of μ_G and σ_G may be estimated for the linearized limit state function and the safety index may again be calculated according to equation (3.8). The problems related to this approach is that the safety index will depend on the choice of linearization point and that it is still not invariant.

Hasofer & Lind (1973) suggested to linearize the limit state function in the so called 'design point' in standard normal space. In standard normal space each variable has zero mean and unit standard deviation. The Hasofer-Lind safety index is thus defined as

$$\beta = \min \left(\sum_{i=1}^n y_i^2 \right)^{1/2} \quad (3.9)$$

where y_i represent the coordinates of any point on the limit state surface in the standard normal space. The point giving the minimum safety index β is the design point, in the following denoted y^* .

The design point represents the point of greatest probability density for the failure domain and the zone of the failure surface closest to y^* gives the greatest contribution to the total probability content in the failure region. α_i are the direction cosines of the design point, as illustrated in Figure 3-4, and the coordinates of y^* can be written

$$y_i^* = -\alpha_i \beta \quad (3.10)$$

$$(\alpha_1^2 + \dots + \alpha_n^2)^{1/2} = 1$$

α_i represent the sensitivity of the standardized limit state function to changes in y_i .

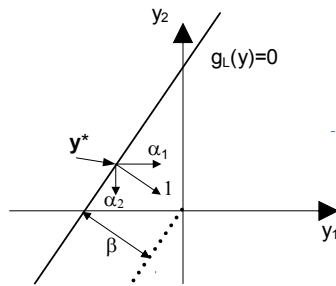


Figure 3-4 - Direction cosines α_i of the design point for a 2D limit state function.

When the limit state function is differentiable, the sensitivity factors may be calculated according to e.g. Thoft-Christensen & Baker (1982) as

$$\alpha_i = \frac{-\frac{\partial g}{\partial y_i}}{\sqrt{\sum_{i=1}^n \left(\frac{\partial g}{\partial y_i}\right)^2}} \quad (3.11)$$

where n is the number of basic variables in the limit state function, $\frac{\partial g}{\partial y_i}$ is the partial derivative of the transformed limit state function $g(\mathbf{y})$ for the normalized basic variable y_i .

Usually an iterative process is performed to determine the safety index and sensitivity factors. First, a design point is assumed. Next, sensitivity factors are determined by (3.11) and the safety index is calculated from

$$g(\beta \cdot \alpha_1, \beta \cdot \alpha_2, \dots, \beta \cdot \alpha_n) = 0$$

Then the new design point is given by $\mathbf{y}^* = \beta \boldsymbol{\alpha}$ and the iteration continues until it converges.

The Hasofer-Lind safety index is invariant to the definition of the limit state function.

From the above description, the safety index β is the minimum distance from the origin to the hyperplane $g(\mathbf{y})$ and α_i gives the direction of the normal to the hyperplane in the design point \mathbf{y}^* . The equation of the tangent hyperplane $g_L(\mathbf{y})$ to the transformed failure surface $g(\mathbf{y})$ through the design point is therefore given by

$$g_L(\mathbf{y}) = \beta + \sum_{i=1}^n \alpha_i y_i \quad (3.12)$$

which will be used in the system reliability discussion in section 3.3.

3.2.2.1. Transformation to standard normal space

For the Hasofer-Lind definition of the safety index, all variables must be independent standard normal variables. For normal distributions, the simple transformation

$$y_i = \frac{x_i - \mu_{x_i}}{\sigma_{x_i}} \quad (3.13)$$

transforms x_i to the standard normal variable y_i . This transformation also affects the limit state function resulting in a transformation according to $G(\mathbf{x}) = 0 \rightarrow g(\mathbf{y}) = 0$. A schematic picture of the transformation in 2D-space is given in Figure 3-5.

For correlated normally distributed variables, a set of uncorrelated variables may be identified by the transformation

$$\mathbf{Z} = \mathbf{A}^T \mathbf{X}$$

where \mathbf{Z} is the uncorrelated set of normal random variables, \mathbf{A} is the orthogonal matrix with column vectors equal to the orthonormal eigenvectors of the covariance matrix of \mathbf{X} (Thoft-Christensen & Baker, 1982). \mathbf{Z} now has to be transformed to standard normal variables \mathbf{Y} using (3.13).

Methods that only use information of the two first moments (mean value and standard deviation) are usually referred to as Second Moment methods. The linearization of the limit state function in the design point is a first order approximation, hence this method is called the First-Order Second Moment method, FOSM.

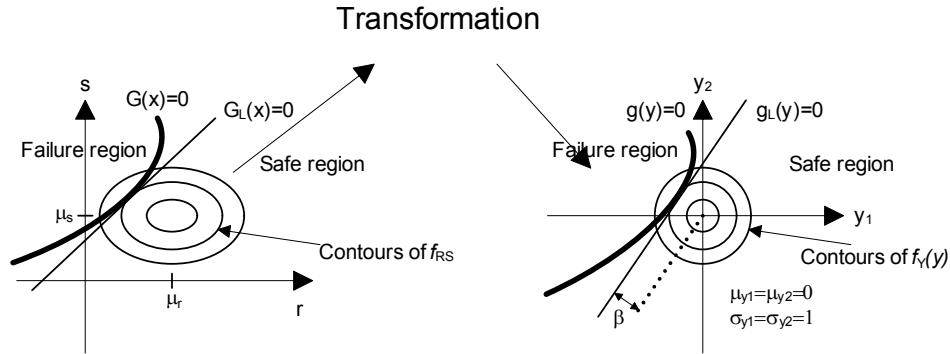


Figure 3-5 - Transformation of normal variable to standard normal space and linearization of limit state function.

In the First-Order Reliability Method (FORM) more information of the probability distribution of non-normal distributions is included in the analysis. This may be achieved by transforming the non-normal distribution to an equivalent normal distribution. One example is the normal tail transformation, where the real and approximated probability density function and cumulative distribution functions are equal in the design point according to

$$F_x(x^*) = \Phi\left(\frac{x^* - \mu_y}{\sigma_y}\right) \quad (3.14)$$

and

$$f_x(x^*) = \frac{1}{\sigma_y} \varphi\left(\frac{x^* - \mu_y}{\sigma_y}\right) \quad (3.15)$$

where Φ is the standard normal distribution and φ is the standard normal probability density function. After this transformation, the variable has to be transformed to standard normal space, using equation (3.13). Other transformation approaches exist, e.g. the Rosenblatt transformation and Nataf transformation that transform directly into standard normal space.

For correlated non-normal variables the Rosenblatt or Nataf transformations will result in a set of uncorrelated standard normal variables. The Rosenblatt transformation requires information of the joint PDF and gives an exact solution, while the Nataf transformation require the marginal PDF to be known and gives an approximate solution.

Common for all transformations is that they have to be performed in the design point. For non-normal distributions, a new approximation of the standard normal variable has to be performed for each of the iterations previously described.

3.2.3 Second-Order Methods

In FORM the limit state function is approximated by a linear limit state function in the design point. For limit state functions of significant curvature, FORM may over- or underestimate the safety index. In that case the Second-Order Reliability Method (SORM) may be applied. In this method, the limit state function is approximated by a second order function, fitted through the design point, e.g. by a Taylor series expansion. This means that the curvature is taken into account when the safety index is estimated. More information of the SORM procedure may be found in e.g. Melchers (1999). For very small probabilities, the FORM and SORM safety index will be nearly the same.

FORM and SORM are so called Level II reliability methods as they compute the probability of failure by means of an idealization of the limit state function and approximate all random variables by equivalent normal distribution functions. One disadvantage is that FORM/SORM can not deal with discontinuous limit state functions or multiple design points. Neither can the system reliability be directly estimated.

3.2.4 Simulation methods

Level III reliability methods are considered more accurate than Level II methods as they compute the exact probability of failure of the whole structural system (or elements) using the exact probability density functions of all random variables. Numerical integration and Monte Carlo simulation are two examples (Waarts, 2000).

In the Crude Monte Carlo sampling technique, values for all variables are randomly drawn from their respective cumulative probability function and the probability of failure is given by

$$p_f = \frac{n(G(x_i) \leq 0)}{N_{trial}} \quad (3.16)$$

where $n(G(x_i) \leq 0)$ is the number of simulations which resulted in violation of the limit state and N_{trial} is the total number of simulations. Crude Monte Carlo simulation requires a large number of simulations, increasing with decreasing p_f , and is not likely to be of use in practical problems. There are also more “clever” sampling techniques, to decrease the number of simulations needed, such as Importance sampling and Directional sampling, see e.g. Melchers (1999).

3.2.5 Analysis of implicit limit state functions

This thesis deals with analytical methods for safety assessment; combining analytical description of failure modes with FORM/SORM. In more demanding problems, where the failure mode can not be described by an analytical model, e.g. in case of non-linear behaviour such as cracking or in case of complex structures, explicit description of the

limit state function is not possible. In such cases, points of the limit state function can be calculated by Finite Element analysis. The combination of finite element analysis and reliability analysis is often called Finite Element Reliability Methods (FERM). Instead of computing the structural behaviour in terms of deformation or stresses, the behaviour is computed in terms of probability of failure and uncertainty contributions (Waarts, 2000). There are, however, some difficulties with this approach. The first is that some type of numerical method must be used and the standard ones (such as MC simulation) requires a very large number of simulations, n , to give an accurate estimate of p_f . As each FE-analysis may only have one set of indata, n different FE-analysis using different indata is needed. The computational effort for this is enormous, even with today's computers. This can be overcome (or at least reduced) by better techniques, such as Monte Carlo Importance sampling, Directional Sampling, Response surface (which may be combined with FORM) etc. see e.g. Waarts (2000) or Melchers (1999). The second is that failure has to be defined in a realistic way. In some cases this is easy, but e.g. for sliding of a concrete dam along the foundation it is a question of definition. When does failure occur? When one element cracks? When 10 elements crack? When all elements crack? This is, to large extent a problem of definition and thus includes decision and modelling uncertainty. Advantages of FERM is that it may give reliability estimates of structures where the analytical description of limit state function is not possible, and that all failure modes are analysed at the same time, hence the system reliability obtained.

3.3 System reliability

In the previous section the reliability of only one failure mode of a component is considered. For a structure with several elements, or where several failure modes may occur, the reliability has to be considered as a system of the elements.

An ideal series system fails if any of its components fail ("weakest link"), therefore

$$P_f = P(\cup E_i) = P(\cup \{G_i(\mathbf{x}) \leq 0\}) = P(\{\min G_i(\mathbf{x}) \leq 0\}) \quad (3.17)$$

where E_i is the event of failure of component i (or in failure mode i).

An ideal parallel system fails if all of its components fail, consequently

$$P_f = P(\cap E_i) = P(\cap \{G_i(\mathbf{x}) \leq 0\}) = P(\{\max G_i(\mathbf{x}) \leq 0\}) \quad (3.18)$$

(Hohenbichler & Rackwitz, 1982).

The difficulty in assessing the system probability of failure is in the calculation of the joint probability, as that is dependant on the correlation ρ_{ij} between the events E_i and E_j .

Figure 3-6 shows an illustration of two events E_1 and E_2 in the sample space Ω with different correlation ρ . An illustration of two limit state functions ($G_1(x_1, x_2)$ and $G_2(x_1, x_2)$) working as a series system and a parallel system is shown in Figure 3-7.

The probability of failure of the system may be easily estimated by simple bounds (i.e. an upper and a lower bound of p_f , with the real p_f somewhere on the interval), but they are often so wide that they are of little use. There are also more narrow bounds, e.g. Ditlevsen bounds that are more useful. p_f may also be calculated directly by integration or Monte Carlo simulation.

For the following discussion, assume that n failure modes (or n elements) have been identified. For each limit state function $G_i(x_1, \dots, x_k, \dots, x_m)$ the safety indices β_i has been derived. g_i is the transformed limit state function in standard normal space according to (3.12):

$$g_n = \beta_n + \alpha_{n1}y_1 + \alpha_{n2}y_2 + \dots + \alpha_{nm}y_m \quad (3.19)$$

where α_{ik} are the FORM influence coefficients for each stochastic variable k of failure mode i . The variables y_k are standard normal variables.

The event E_i is defined as the event of $g_i \leq 0$.

The correlation between failure modes i and j can be calculated according to

$$\rho_{ij} = \sum_{k=1}^n \alpha_{ik} \alpha_{jk} \quad (3.20)$$

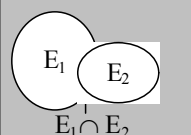
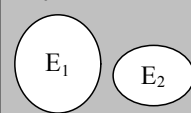
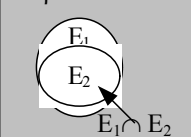
$0 < \rho < 1$  Ω	Series system $P_f = P(E_1) + P(E_2) - P(E_1 \cap E_2)$	Parallel system $P_f = P(E_1 \cap E_2)$
$\rho = 0$  Ω	$P_f = P(E_1) + P(E_2)$	$P_f = 0$
$\rho = 1$  Ω	$P_f = P(E_1) + P(E_2) - P(E_1 \cap E_2) = P(E_1)$	$P_f = P(E_1 \cap E_2) = P(E_2)$

Figure 3-6 - Illustration of correlation between events.

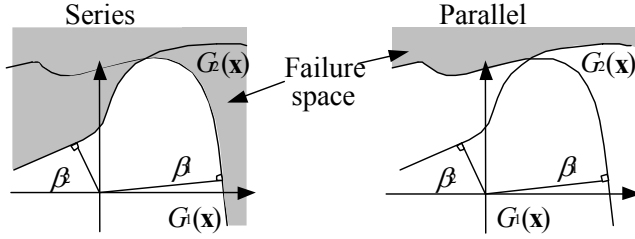


Figure 3-7 - Illustration of two limit state functions as series system and parallel system.

3.3.1 Reliability bounds

For a *series system* the simple bounds are

$$\max_{i=1}^n P(E_i) \leq P_f \leq 1 - \prod_{i=1}^n (1 - P(E_i)) \quad (3.21)$$

The Ditlevsen narrow bounds for the probability of failure of a series system, see e.g. CUR Publicatie 190 (2006) or Efstratidos (2005) are

$$P(E_i) + \sum_{i=2}^n \max \left[\left(P(E_i) - \sum_{j=1}^{i-1} P(E_i \cap E_j) \right), 0 \right] \leq P_f \leq \sum_{i=1}^n \left(P(E_i) - \max_{j < i} P(E_i \cap E_j) \right) \quad (3.22)$$

In the lower bound an estimation of the combined event E_i and E_j is

$$P(E_i \cap E_j) = \Phi(-\beta_i^*) \Phi(-\beta_j) + \Phi(-\beta_i) \Phi(-\beta_j^*) \quad (3.23)$$

and in the upper bound

$$P(E_i \cap E_j) = \Phi(-\beta_i^*) \Phi(-\beta_j) \quad (3.24)$$

where

$$\beta_i^* = \frac{\beta_i - \rho_{ij} \beta_j}{\sqrt{1 - \rho_{ij}^2}} \quad (3.25)$$

For a *parallel system* the simple bounds are

$$\prod_{i=1}^n P(E_i) \leq P_f \leq \min_{i,j=1}^n (P(E_i)) \quad (3.26)$$

for $\rho_{ij} > 0$

The more narrow Ditlevsen bounds are (see e.g. Efstratidos (2005) or CUR Publicatie 190 (2006))

$$\prod_{i=1}^n P(E_i) \leq P_f \leq \min_{i,j=1}^n (P(E_i \cap E_j)) \quad (3.27)$$

for $\rho_{ij} > 0$

$P(E_i \cap E_j)$ is calculated by integration, shown below, or according to the Ditlevsen assumption of upper bound shown in eqn (3.24).

3.3.2 Integration

The exact joint probability of failure of two components, $P(E_i \cap E_j)$ can be found from the bivariate standard normal distribution (Hohenbinchler & Rackwitz (1982), Efstratidos (2005)).

$$\Phi_2(E_i, E_j; \rho_{ij}) = \int_{-\infty}^{E_j} \int_{-\infty}^{E_i} \varphi_2(t_i, t_j; \rho_{ij}) dt_i dt_j \quad (3.28)$$

where

$$\varphi_2(t_i, t_j; \rho_{ij}) = \frac{1}{2\pi\sqrt{1-\rho_{ij}^2}} \exp\left(-\frac{1}{2(1-\rho_{ij}^2)}(t_i^2 + t_j^2 - 2\rho_{ij}t_it_j)\right) \quad (3.29)$$

Observe that the system is now in standard normal space and “exact” refer to this space.

An approximation of P_f for a series system of two elements can then be obtained (see e.g. Efstratidos, 2005) and β_{sys} can be calculated as

$$\beta_{sys} = -\Phi^{-1}(P_f) \approx -\Phi^{-1}(1 - \Phi_2(\beta_i, \beta_j; \rho_{ij})) \quad (3.30)$$

For a parallel system of two elements

$$\beta_{\text{sys}} = -\Phi^{-1}(P_f) \approx -\Phi^{-1}(\Phi_2(-\beta_i, -\beta_j; \rho_{ij})) \quad (3.31)$$

For a system with n elements this procedure is repeated with two elements until the whole system reliability is obtained, or the joint probability of failure for the n elements is calculated by a multivariate standard normal distribution of n -dimensions (Φ_n).

3.3.2.1. Finding sensitivity values of the system reliability

When the system reliability of two elements or failure modes is calculated, the sensitivity factors from the original limit state functions is no longer valid. To find the sensitivity factors for the system, the following procedure can be adopted:

- For the original limit state function, calculate β_i and associated α_{ik} and β_j and associated α_{jk} by some method (e.g. FORM). The transformed limit state functions in standard normal space can now be written as

$$\begin{aligned} g_i &= \beta_i - \alpha_{i1}y_1 - \dots - \alpha_{im}y_m \\ g_j &= \beta_j - \alpha_{j1}y_1 - \dots - \alpha_{jm}y_m \end{aligned} \quad (3.32)$$

- Calculate β_{sys} by integration or Monte Carlo simulation (shown below). The limit state function for the system is

$$g_{ij} = \beta_{\text{sys}} - \alpha_1y_1 - \dots - \alpha_my_m \quad (3.33)$$

- Increase the mean value of variable k in the g_i and g_j equations by ε , giving

$$\begin{aligned} g_i' &= \beta_i - \alpha_{i1}y_1 - \dots - \alpha_{ik}(y_k + \varepsilon_k) - \dots - \alpha_{im}y_m \\ g_j' &= \beta_j - \alpha_{j1}y_1 - \dots - \alpha_{jk}(y_k + \varepsilon_k) - \dots - \alpha_{jm}y_m \end{aligned} \quad (3.34)$$

and calculate the new β_{sys}' .

- Approximate values of α_k can be obtained from

$$\alpha_k = \frac{\delta\beta}{\delta\varepsilon_k} = \frac{\beta_{\text{sys}}' - \beta_{\text{sys}}}{\varepsilon_k} \quad (3.35)$$

If there are more than two failure modes, this procedure can be used successively until only the limit state and sensitivities for the complete system remains.

3.3.3 Monte Carlo simulation

In case the reliability is simulated using a Monte Carlo simulation, the system reliability of n elements or failure modes may be found directly by the following equations;

$$g_{sys} = \min(g(\mathbf{y})_1, g(\mathbf{y})_2, \dots, g(\mathbf{y})_n) \quad (3.36)$$

for a series system, and

$$g_{sys} = \max(g(\mathbf{y})_1, g(\mathbf{y})_2, \dots, g(\mathbf{y})_n) \quad (3.37)$$

for a parallel system. The Monte Carlo simulation will not give any indication of the sensitivities.

3.3.4 Failure of brittle parallel systems

Modelling of materials that exhibit brittle failure is complex as combinations of failed and un-failed components have to be studied. For the case of equal load-sharing there exist some asymptotic results, hence for a system of n components with brittle behaviour the resistance is given by Hohenbichler & Rackwitz (1981, after Daniels) as:

$$R_n = R_n(c_1 \dots c_n) = \max\{n \cdot \hat{c}_1, (n-1) \cdot \hat{c}_2 \dots \hat{c}_n\} \quad (3.38)$$

Where

$$\hat{c}_1 \leq \hat{c}_2 \leq \dots \hat{c}_n$$

are the order statistics of $c_1 \dots c_n$.

3.4 Bayesian updating

In the assessment of existing structures knowledge of the actual behaviour, loads and material properties can be used as input in the reliability analysis, by the use of Bayesian updating.

General information of material properties can often be obtained from building documentation and it is often also possible to estimate the V_x (coefficient of variation) from knowledge of the material (information of this is available in e.g. JCSS (2001)). This information is however generic in nature and not connected to a specific structure.

The generic information can be used as so called *a priori* information. In an existing structure material properties can be measured (e.g. by testing of samples) and by use of this new information and the *a priori* distribution an *a posteriori* distribution of the material property can be obtained. More information of Bayesian updating of material properties can be found in e.g. Thelandersson (2004), Melchers (1999) and JCSS (2001).

As pointed out by Vrijling & van Gelder (1998) it is important to discern between inherent uncertainty in time and space. The inherent uncertainty in time will remain uncertain and unlimited data will only affect the epistemic part of the uncertainty. An example of this is the ice load. In the start assumption, the ice load has both aleatory and epistemic uncertainty, but if it is monitored for a long time the epistemic uncertainty

will decrease with the gained knowledge. The aleatory part, on the other hand is still present due to the random nature of the load. The inherent uncertainty in space, on the other hand, will decrease with time - even without measuring. The reason is that this uncertainty is from a different kind. Properties of the foundation or the structural strength have only one realization per lifetime. This means that, without further investigation, the knowledge of the foundation will increase with time when a larger load than before is survived (Bayesian updating of strength). In this case the aleatory uncertainty is also possible to decrease.

As pointed out by Melchers (1999) a long service time does not necessarily imply that the structure has withstood large forces and these are the most likely to cause failure, hence caution is necessary when including this kind of information. If the structural strength is or may be assumed to decrease with ageing, Bayesian updating of the strength may not be applied.

3.5 Methods for reliability design

Often in the discussion of reliability analysis three categories are distinguished:

- Level 3 methods: attempt to obtain the best estimate of the probability of failure, making use of a full probabilistic description of the joint occurrence of various quantities and taking the true nature of the failure domain into consideration. These methods are not useful in practise.
- Level 2 methods: methods involve approximate iterative calculation procedure to receive the nominal probability of failure, using simplified representation of the joint probability distribution and idealisation of the failure domain. Structural reliability analysis as previously described falls into this category.
- Level 1 method: the partial factor approach; a semi-probabilistic version of the traditional safety factor, commonly used in design.

The factor of safety is not included in this categorization as it is deterministic.

Traditionally, safety factors were selected largely on the basis of intuition and experience, but level 2 methods (e.g. structural reliability analysis) made it possible to relate the partial factors of the level 1 methods to the safety index β or the failure probability p_f (Melchers, 1999).

3.5.1 Method and calibration of partial factors

Design of structures according to e.g. BKR (2003) and Eurocode (EN1990, 2004) is performed on basis of the method of partial factors. This method is based on characteristic values and partial factors. For calculation of limit states, load combinations are defined. Account is taken to the probability of one or more actions occurring simultaneously with high values. Strongly correlated actions are regarded as one action, whereas actions supposed to be mutually exclusive are not combined (NKB 55E, 1987).

In Eurocode (EN1990, 2004) a the general format of effects of actions, E_d , is described as

$$E_d = \gamma_{Sd} E \left\{ \sum \gamma_{G,j} G_{k,j} + \gamma_P P + \gamma_{Q,1} Q_{k,1} + \sum \gamma_{Q,i} \psi_{0,i} Q_{k,i} \right\} \quad (3.39)$$

where γ_{Sd} is the partial factor associated with the uncertainty of the action and/or action effect model, E is the “effect of actions”, $\gamma_{G,j}$ is the partial factor for permanent action j , $G_{k,j}$ is the characteristic value of permanent action j , γ_P is the partial factor for prestressing actions, P is the prestressing action, $\gamma_{Q,1}$ is the partial factor of for the leading variable action 1, $Q_{k,1}$ is the characteristic value of the leading action 1, $\gamma_{Q,i}$ is the partial factor of the accompanying variable action i , $Q_{k,i}$ is the characteristic value of the accompanying action i , $\psi_{0,i}$ is the combination value of variable action i .

The design value, R_d , of a resistance variable is given as

$$R_d = \frac{R \left\{ \frac{\eta X_k}{\gamma_m}; a_d \dots \right\}}{\gamma_{Rd}} \quad (3.40)$$

where R is the resistance, η is a conversion factor, X_k is the characteristic value of a material property, γ_m is the partial factor for a material property, a_d is design values of geometrical data and γ_{Rd} is the partial factor associated with the uncertainty of the resistance model.

The characteristic value is defined so that it has a certain probability of being exceeded, i.e. the $x\%$ -fractile.

- For resistance parameters the value of x depend on i.e. the variability, but is typically around 5 % for variables with significant variability.
- For action effect the characteristic value, in BKR (Boverket, 2003), is defined as the mean value (i.e. 50%-fractile) for permanent actions and the 98%-fractile of annual maximum for variable loads.

When the characteristic value of a variable action, $Q_{k,j}$ is combined with $\psi_{0,i}$ a frequent value is received (Melchers (1999), Eurocode (EN1990, 2004), NKB 55E (1987), BKR (2003)).

The procedure to calibrate the partial factors can be described by the flowchart shown in Figure 3-8. The boxes in grey are where structural reliability analysis is performed. More information is found in e.g. Melchers (1999), NKB 55E (1987), NKB 1995:02 (1995) and Thoft- Christensen & Baker (1982).

The aim is to end up with

- An acceptable probability of failure and which is, as far as possible, independent of the kind of load, type of structure and material, but differ between consequence classes.
- Partial coefficients of loads independent of type of structure and material, partial coefficients of strength values independent of the type of load.

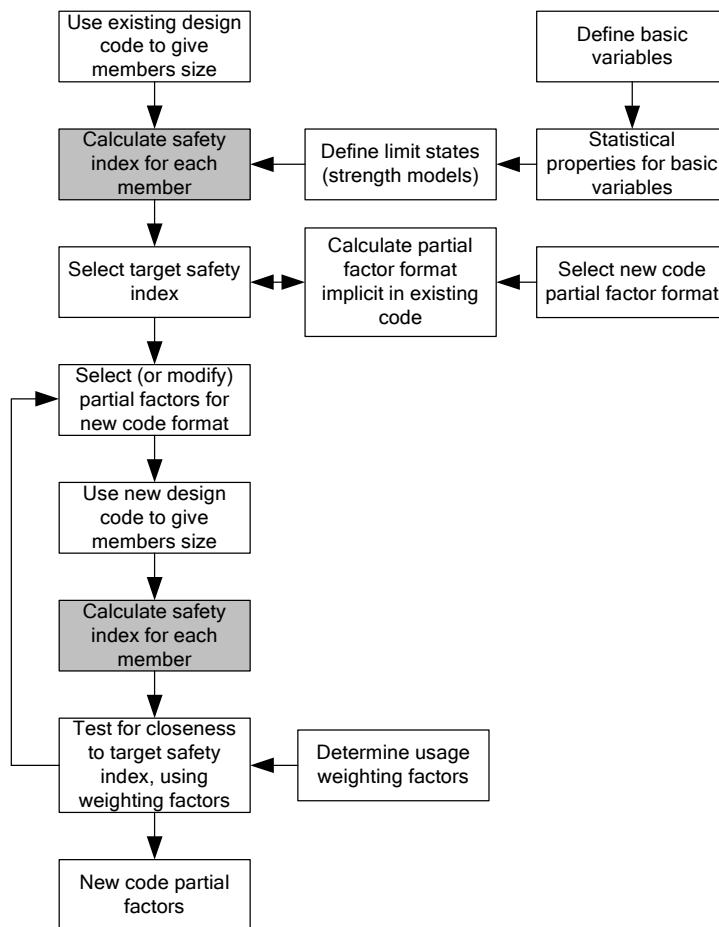


Figure 3-8 - Flow chart of code calibration, partly after Melchers (1999). Structural reliability analysis is indicated with gray.

Structural reliability analysis, definition of relevant limit states, definition of basic variables and statistical properties for basic variables are all essential elements needed if calibration is to be performed for concrete dams.

3.6 Target safety index

In order to determine if the safety index calculated for a specific structure is sufficient, i.e. if the structure is safe enough, comparison to a target safety index is necessary. The safety of the structures is expressed in terms of the accepted minimum safety index or the accepted maximum failure probability.

The derivation of a target safety index is very complex and should be made by scientists, designers and politicians in cooperation. This may be a utopian dream, but it must be emphasized that decisions on tolerable risk and target safety have impact on society as a whole and should not be performed solely on the basis of engineering judgement. Derivation of target safety index could be performed on the basis of tolerable risks, but this is a difficult and controversial approach.

It is important to note that the probability of failure (corresponding to the safety index) does not account for human error and human intervention effects and includes approximations. The result is that the failure probability becomes a nominal one. This is not a problem as long as it is used in a comparative manner between components. When it is used as a measure of the safety of a structure against more general societal risk criteria, human error and other effects may have significant influence and the comparison is thus not straightforward (Melchers, 1999).

3.6.1 Target safety index in different structural codes

For civil structures (houses, bridges etc) in Sweden, the EU and other parts of the world target safety indices are specified, but this is not so for Swedish dams (there is for Chinese dams (China Electricity Council, 2000), but this appears to be the only exception throughout the world). Two major arguments against the use of probability based evaluation of dams in Sweden are related to the lack of target safety index:

- The safety format used is based on safety factors and target safety index has thus not been needed
- The authorities does not specify the safety level, partly due to the strict responsibility of the dam owner discussed in chapter 2.

The most common way to find a target safety index for structural design is by calibration to existing practice as will be discussed.

Target safety index given in Schneider (1997), BKR (2003), EN1990 (2001) and JCSS (2001) will be compared here and those according to China Electricity Council (2000) are shown in section 4.4. Only values for the ultimate limit state are discussed. The purpose of this part is to give an apprehension of the possible region of the target safety index, and to describe variables that influence it.

The relation between safety index and probability of failure for normal variables is given by

$$p_f = \Phi(-\beta) \quad (3.41)$$

where Φ is the cumulative distribution function of the standard normal distribution and Table 3-1 show the relation.

Table 3-1 - Relation between safety index and p_f .

p_f	0.5	10^{-1}	10^{-2}	10^{-3}	10^{-4}	10^{-5}	10^{-6}	10^{-7}	10^{-8}	10^{-9}
β	0	1.28	2.33	3.09	3.72	4.26	4.75	5.20	5.61	6.0

In JCSS (2001) it is pointed out that risk-benefit (cost-benefit) analyses should be applied when expected casualties are of importance.

Since risk is a product of the probability and consequence of failure, different failure probabilities are tolerated for high and low consequences. Table 3-2 from Schneider (1997) gives target safety index depending on type of structure and type of failure.

Table 3-2 - Target safety index β /year, from Schneider (1997).

		Type of failure			
		Type A - serviceability	Type B - ductile	Type C - ductile, non-redundant	Type D - brittle, non-redundant
Consequences	Class 1 - no consequences	1	1.5	2	2.5
	Class 2 - minor consequences	1.5	2	2.5	3
	Class 3 - moderate consequences	2	2.5	3.5	4
	Class 4 - large consequences, medium hazards to life (bridges etc)	2.5	3	4.5	5
	Class 5 - Extreme consequences, high hazards to life (large dams etc)	3	4	5	6

Large dams often fall into the class 5 as the consequences can be extreme, either to human life or in economic consequences. Swedish dams are often placed in so called cascades, and the result of one dam breach can thus be the failure of several downstream dams as well. It must be pointed out, however, that this is not always the case. In many cases failure of a concrete dam would result “only” in loss of part of the dam and emptying of the reservoir (but still this might cause damage to downstream area). Emergency plans are available for most dams and consequences in human lives as well as in downstream consequences for other dams can thus be mitigated. Dams do not

have redundancy and will in many cases (e.g. sliding of a concrete dam) exhibit brittle behaviour with no or very short warning. If consequences are large the resulting required β value is thus around 6, corresponding approximately to a probability of failure of 10^{-9} /year.

In Swedish design guidelines (for bridge and buildings, dams not included) the required safety level is given in Table 3-3 below. The highest safety class, 3, is for structures where failure could result in loss of human lives.

Table 3-3 - Target safety index from BKR (2003).

Safety Class	β /year
1	3.7
2	4.3
3	4.8

In Eurocode (EN1990, 2004) target values for the reliability index β for the ultimate limit state is given for reference periods of 1 year and 50 years. Consequence classes CC1-CC3 are defined according to Table 3-4 and the reliability classes RC1 to RC 3 of Table 3-5 are associated with those consequence classes.

When the main uncertainty comes from actions that have statistically independent maxima in each year, the values of β for a reference period of n years can be calculated according to

$$\Phi(\beta_n) = [\Phi(\beta_1)]^n \quad (3.42)$$

where β_n is the reliability index for a reference period of n years and β_1 is that for a reference period of 1 year. This can also be expressed as

$$p_{fn} = 1 - (1 - p_{f1})^n \quad (3.43)$$

where p_{fn} is the probability of failure during the n year reference period and p_{f1} that during 1 year.

Table 3-4 - Definition of consequences classes. From Eurocode (EN1990, 2004).

Consequences class	Description	Examples of buildings and civil engineering works
CC3	High consequence for loss of human life, <i>or</i> economic, social or environmental consequences very great	Grandstands, public buildings where consequences of failure are high (e.g. A concert hall)
CC2	Medium consequence for loss of human life, economic, social or environmental consequences considerable	Residential and office buildings, public buildings where consequences of failure are medium (e.g. An office building)
CC1	Low consequence for loss of human life, <i>and</i> economic social or environmental consequences small or negligible	Agricultural buildings where people do not normally enter (e.g. Storage buildings, greenhouses)

Table 3-5 - Target safety index, from Eurocode (EN1990, 2004).

Reliability class	Minimum value for β	
	1 year reference period	50 years reference period
RC3	5.2	4.3
RC2	4.7	3.8
RC1	4.2	3.3

JCSS (2001) proposes target reliability values for ultimate limit states as shown in Table 3-6. These were obtained based on cost benefit analysis for the public at characteristic and representative, but simple, example-structures and are compatible with calibration studies and statistical observations. In this table ρ_c is defined as the ratio between total costs (construction costs plus direct failure costs) and construction costs.

It is pointed out that the type of failure is also of importance; a structural element that could collapse suddenly without warning should be designed for a higher level of reliability than an element where collapse is preceded by warning enabling consequence-reduction measures.

For most structures target values of the moderate consequences can be applied.

The relative costs of safety measure are given classes A-C. The normal class (B) is associated with medium variability, normal design life and normal obsolesce rate. If large uncertainties ($V_x > 40\%$) are associated with loading or resistance, a lower reliability class (A) should be used, as the additional costs to achieve a high reliability are prohibitive. For low uncertainties ($V_x < 10\%$) a higher reliability class (C) should be used as the increase of reliability can be achieved by very little effort.

For existing structures the costs of achieving a higher reliability level are high compared to the costs for a structure under design and therefore the target level should be lower. For structures designed for short service life, the safety index can be lowered by one or half a class.

Quality assurance (new structures) and inspections (existing structures) will make it possible to reduce the reliability class as uncertainties are reduced. Such measures, however, have an increasing effect on costs, and a higher class becomes more economically attractive.

Lower target reliability for existing structures is also pointed out by R ddningsverket (1997) "risks related to new activities should be lower than those tolerated for existing activities for the following reasons:

- o The aim of society is, and has been, to continuously improve the safety level
- o It is easier to achieve risk reduction during design of new construction than by making changes in existing ones
- o Choice of location can be used to reduce the risk level for the public in new activities (perhaps not applicable to dams, but rather to industries).

Table 3-6 - Target safety index β /year, from JCSS. ρ = total costs/construction costs.

Relative cost of safety measure	Minor consequences of failure $\rho_c < 2$	Moderate consequences of failure $2 < \rho_c < 5$	Large consequences of failure $5 < \rho_c < 10$
Large (A)	$\beta = 3.1$	$\beta = 3.3$	$\beta = 3.7$
Normal (B)	$\beta = 3.7$	$\beta = 4.2$	$\beta = 4.4$
Small (C)	$\beta = 4.2$	$\beta = 4.4$	$\beta = 4.7$

As is seen in the above comparison, a number of different target safety indices exist. Most systems define different target safety indices depending on safety level. Only JCSS (2001) specifically gives different target index if the structure is already existing or meant to be built.

Obviously there are many different variables that may be included when target safety index is defined; consequences of failure, type of failure, uncertainties in input parameters, if the structure is an existing one or to be built etc. Target safety index can be derived on the basis of calibration to existing practice or on the basis of cost-benefit, but as will be discussed in chapter 5 it could also be derived from tolerable risk, though this approach is not easily applicable.

3.6.2 Calibration to existing practice

According to Schneider (1997) target safety index can be calibrated to existing practice, assuming that existing practice is optimal. There are reasons to believe that this is true, as practice would change quickly if design of structures often resulted in failure. A way to proceed in the calibration of target safety index is to design a set of typical structures

or structural elements according to existing codes with random parameters (loads and resistance) and uncertainties fixed. From these assumptions the reliability index β of each of the elements with respect to their requirements can be calculated. Iteration back and forth will result in a set of β -values within acceptable bounds and within these bounds a target reliability level β_0 can be found. This procedure has been used to calibrate national codes in many countries as well as the Eurocode (see e.g. EN1990, 2004) and BKR (2003).

In the Chinese guidelines (China Electricity Council, 2000) a procedure for calibration of the target safety index is suggested and in short this is to

- Select typical structures or structural elements and divide into three groups in accordance with their safety grade (consequence class).
- For each structure or structural element a coefficient ω_i is assigned, according to frequency of use, cost and experience of the structural type, and for each group

$$\sum_{i=1}^n \omega_i = 1 .$$

- The typical structures are designed according to current codes and the amount of material used is minimized.
- Stochastic parameters and probability distributions of actions and resistance are used as input to determine β_{i1} for each of the typical structures.
- The weighted reliability index, β_1 , of a group of structures with the same safety level is determined. This reliability index is an index calibrated at this safety level according to relevant codes.
- Existing typical structures are grouped according to safety level and the reliability index is determined for each structure. For each group of structures of the same safety level, a weighted reliability index β_2 is determined.
- The target reliability index β_T is determined for each safety level according to β_1 , β_2 (i.e. taking account to both existing structures, β_2 , and typical “designed” ones, β_1) and taking account of the optimal balance of safety and economy.

In NKB 55E (1987) the determination of the target safety index was based on comparative calculations carried out for more or less specific structures chosen from structures of common occurrence. The result is normally a number of values varying within relatively wide limits, as the safety level is non-uniform, and the final choice of β_T must therefore be based on assessment of the calculation results.

4. Concrete dams, failure modes and design

In this chapter concrete dams common in Sweden are briefly described.

In section 2 a short discussion on known failures with the focus on failure causes is given.

Section 3 deals with failure modes and from the described failure modes, limit state functions are defined.

4.1 Concrete dams in Sweden

In principle dams can be divided into three groups, characterized by building material: earth or rock fill dams, masonry dams and concrete dams.

Concrete dams are, in turn, divided into three groups: gravity dams, buttress dams and arch dams. There are also hybrids, like arch-gravity dams, concrete faced rock fill dams etc, but in Sweden those are not represented. Arch dams are mainly built in narrow, steep valleys where the hydrostatic force from the reservoir can be transmitted horizontally to rock on the banks. Only a few arch dams have been built in Sweden, mainly because this is not the common type of Swedish valley as mentioned in Bernstone (2006). Instead, Swedish concrete dams are in general gravity or buttress dams, see Figure 4-1 and Figure 4-2. For gravity dams, see Figure 4-3, the self-weight of the dam is sufficient to withstand the hydrostatic forces and transmit them to the ground.

Buttress dams, see Figure 4-4, consists of an inclined or vertical front plate supported by columns that transfer the hydrostatic forces to the ground. This design significantly reduces the concrete volume compared to gravity dams.



Figure 4-1 - Gravity dam at Stadsforsen.



Figure 4-2 - Buttress dam at Stornorrfors.

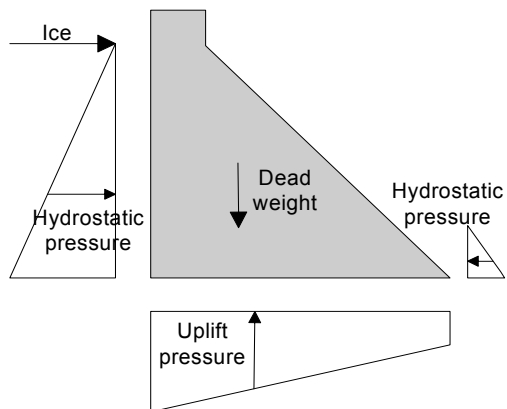


Figure 4-3 – Main forces of concrete gravity dam.

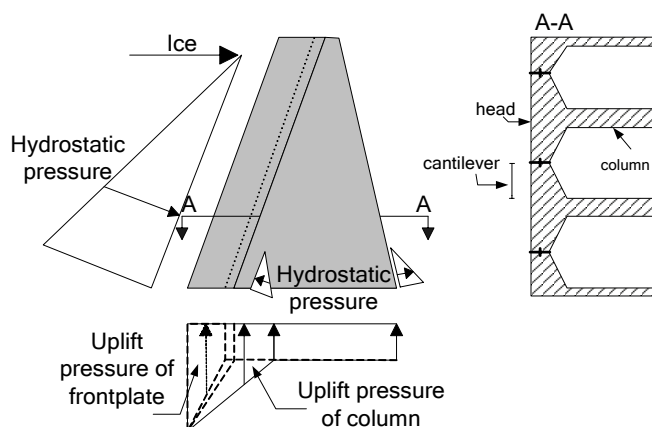


Figure 4-4 – Main forces of buttress dam.

Figure 4-5 is from Bernstone (2006) and show year of completion of 212 Swedish concrete dams (dams with > 80 % concrete parts). This figure includes both high dams (dams of height > 15 m according to ICOLD), and low dams. It should be noted that rock and earth fill dams are usually associated with concrete intake and discharge facilities, which means that almost all Swedish dam facilities has at least one concrete dam part. Sweden has few high dams, mainly because of the topography with wide valleys, as mentioned above. In addition to these concrete dams, most dam sites dominated of earth or rock fill dams has intake and discharge facilities made of concrete. The behaviour of these are similar to that of concrete gravity or buttress dams and the discussion in this chapter is thus applicable, even though geometries and loading conditions may be more complicated.

The situation in Sweden is, and has been during the last decade, that no new establishments of dams are under consideration. Instead focus has mainly been on maintaining the ageing dam portfolio at an acceptable safety level or to make improvements to reach this level, and building and construction of new dams has been essentially zero. This situation is now slowly changing, as some of the oldest dams have to be improved or completely rebuilt to fulfil today's safety requirements. It must be pointed out that the vision in the Swedish design guidelines RIDAS (2008) is continuous dam safety improvements, and thus the sufficiently safe level can change with time.

The resistance of a concrete dam is due to its geometry and self-weight and to shear, compressive and tensile strength of concrete, foundation and, where relevant, reinforcement. The most important forces are hydrostatic force, ice load and uplift pressure. These factors will be treated more in detail later. Forces from sediment and earthquakes are of importance in many parts of the world, but not in Sweden. Earth pressure and traffic load can be of importance and loads of temperature, shrinkage and creep are often substantial, but neither is treated in this thesis.

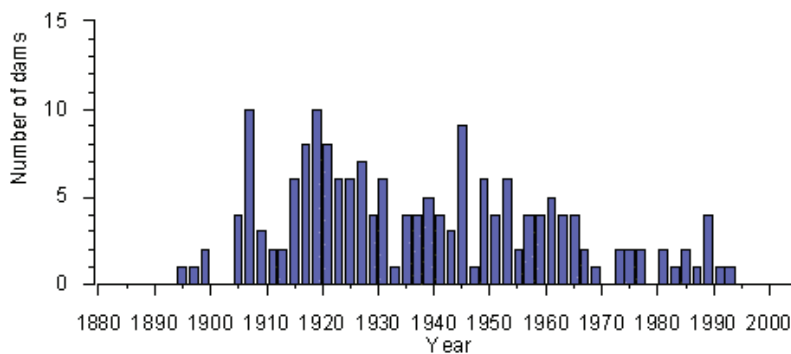


Figure 4-5 - Year of completion of Swedish concrete dams (from Bernstone, 2006).

4.2 Failures of concrete dams

According to ICOLD (1998) the frequency of dam failures is approximately the same for all dam heights. The largest number of failures is among new dams, with more frequent failure rate the first 10 years after construction and especially during first fill.

Douglas et al. (1999) summarized the historic failures of concrete and masonry gravity dams. All failure modes are included and the results are shown in Table 4-1. Obviously the dams built before 1930 has a much higher failure frequency than those built after this year.

Table 4-1 - Historic annual frequency of failure of concrete and masonry dams (after Douglas et al., 1999).

Year Commissioned	Annual frequency of failure x 10 ⁻⁵					
	Concrete gravity			Masonry Gravity		
	Overall	First 5 years	After 5 years	Overall	First 5 years	After 5 years
1700-1929	15	100	9	54	520	34
1930-1992	3.5	14	1.4	42	160	24

4.2.1 Causes of failure

As summarised by FEMA (2006) concrete dams fail for one or combinations of the following factors:

- Overtopping caused by floods that exceed the discharge capacity.
- Deliberate acts of sabotage.
- Structural failure of materials used in dam construction.
- Movement and/or failure of the foundation supporting the dam.

- Settlement and cracking of concrete dams.
- Inadequate maintenance and upkeep

ICOLD (1995) gives a summary of dam failures and Figure 4-6 shows the reasons for concrete dam failures. Foundation problems are the most common cause, internal erosion and insufficient shear strength of the foundation each account for 21 percent of the failures. Of all concrete dam failures, insufficient capacity of spillways during passage of maximum floods was the primary cause of about 22 percent of the dam failures and secondary cause in about 39 percent of the failures.

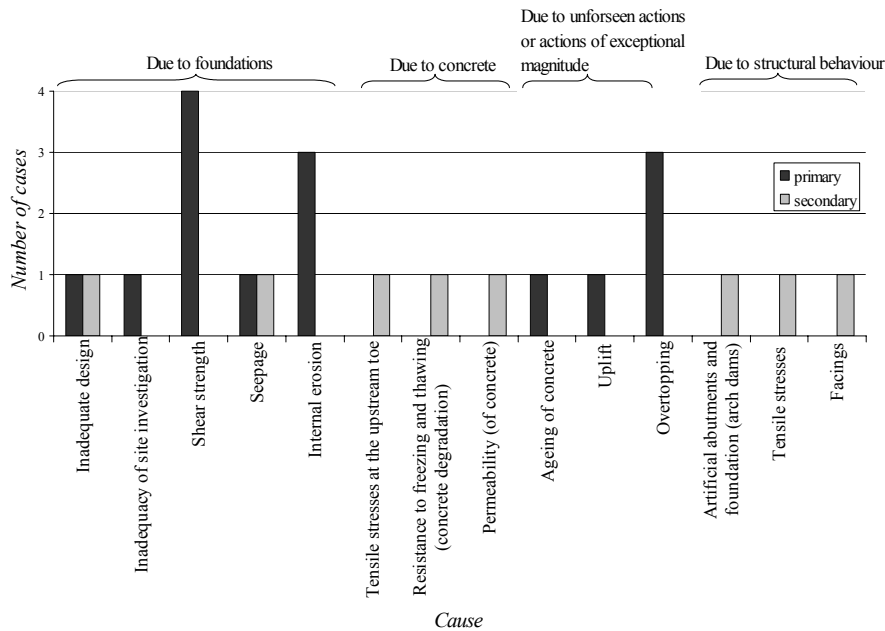


Figure 4-6 - Cause of dam failures, after ICOLD (1995).

According to ICOLD (1998) a concrete dam may withstand significant overtopping and the limiting factor in such conditions is the erosion of the foundation or abutments. Structural failure is usually due to weak foundation, structural deficiencies or sabotage. The failure of arch and buttress dams is usually assumed to be instantaneous while gravity dams are assumed to have relatively short but not instantaneous failure time.

4.3 Failure modes for analysis

The failure modes of concrete dams, described in literature and design guidelines, are:

- Sliding. Sliding of the whole dam section or a monolith, or part thereof along the concrete to rock interface, lift joints (construction joint) in the dam body or along weak planes in the foundation.

-
- Overstressing. Ultimate stresses exceed ultimate strength in foundation or dam body.
 - Overturning. Overturning of the whole monolith or part thereof. This failure mode is not explicitly accounted for in some guidelines, as will be shown later in this chapter.

The failure modes are of major importance in dam design and assessment. If the failure modes identified are not the most essential, meaning that there are unidentified or neglected modes which will occur with higher probability, or if the mechanical description of the failure mechanism is wrong, the outcome of the analysis will not reflect reality – no matter the refinement of calculation methods or knowledge of input parameters

The failure of a structure should be treated as a series system, where the reliability is defined by the weakest link. As pointed out in chapter 2 dam safety has to consider the safety of the whole system, hence the ability of the dam to retain water is only one piece of the puzzle.

The rigid body analysis, where the monoliths of the dam are considered and analysed as separate parts does not account for 3D effects that may give additional resistance. Those include e.g. friction between the monoliths and wedge effects. Du (2009) analysed the behaviour of a concrete core of a rockfill cofferdam, 4 m thick, 18 m high and with a total length of 86.4 m. This concrete core, despite not being stable according to calculation, survived overtopping where the supporting rockfill was washed away as well as serious scouring of the downstream rock (partly beneath the core), still withstanding the upstream water and sediment. A finite element back-analysis showed that the concrete core behaved as an “intrinsic arch”, i.e. that the compressive stress distribution in the concrete core is similar to that in an arch dam. The author concludes that this intrinsic arch action may exist in straight concrete dams in U-shaped valleys with a cord-height ratio of about five.

4.3.1 Sliding

The most used and accepted methods to evaluate safety against sliding regard the dam as a rigid body allowed to slide along its base or lift joints, or along critical surfaces in the foundation. Sliding surfaces are defined based on judgement of the most probable ones and occur when the resisting force (shear strength) is insufficient compared to the driving forces. Swedish dams are mainly founded on rock and this is in focus here.

4.3.1.1. Sliding along the concrete-rock interface

There are different approaches how to evaluate the shear strength; some methods use forces along the entire sliding surface, others differentiate the area of the sliding surface where normal stresses are compressive from that where tensile stresses exceed the tensile strength (cracked base analysis, which will be further discussed in 4.3.3.1) (Ruggeri et al., 2004).

4.3.1.1.1. Description in different guidelines

In all codes known to the author; RIDAS (2008), FERC (2002), Bureau of Reclamation (1987), U.S. Army Corps of Engineers (2003), Canadian Dam Association (1999), China Electricity Council (2000), FRCOLD (2006) and those described by Ruggeri et al. (2004) the sliding stability calculations are based on the Mohr-Coulomb constitutive model where the maximum allowed tangential stress τ for each point of the sliding surface is described as

$$\tau \leq c + \sigma_n \cdot \tan \phi \quad (4.1)$$

c is the cohesion, σ_n is the effective normal stress to the sliding surface and ϕ is the friction angle. For more information of the above, please refer to e.g. Ruggeri et al. (2004), Westberg (2007), Johansson (2005).

When σ_n and τ are integrated over the sliding plane, the safety condition becomes

$$T \leq \frac{cA + N \cdot \tan \phi}{sf} \quad (4.2)$$

where T is the resultant forces parallel to the sliding plane, N the resultant forces normal to it, ϕ the friction angle, c the cohesion and A the contact area and sf is the safety factor applied. As mentioned in Ruggeri et al. this expression considers that, at failure, the ultimate capacity is reached at each point on the sliding surface. This is, however, true for ductile materials, but sliding planes can often be considered semi-brittle.

Ruggeri et al. investigated the regulatory rules and guidelines concerning sliding stability of existing dams and found that only two of fourteen countries in the investigation (Sweden and Italy) apply the simple criteria where the safety assessment is based on the ratio T/N between the resultant of the forces parallel (T) and perpendicular (N) to the sliding surface, hence not accounting for any cohesion. Of the countries investigated, six applied one safety factor for both friction angle and cohesion, whereas six differentiate them from each other, applying larger safety factors for cohesion. In many countries it is not explicitly stated if peak or residual values are to be used for the shear strength parameters. Where it has been defined, the safety factors used vary depending on if peak or residual strength is used. Differentiation is also made depending on if the strength values are based on laboratory or in-situ testing or on values given in the code.

4.3.1.1.2. Background

According to Gustafsson et al. (2008) the failure of a concrete-rock interface where cohesion exists is brittle and will occur at no or very small relative displacement in the failure surface. Until failure occurs, the shear resistance may be described by the Mohr-Coulomb failure criteria with cohesion c and internal friction angle, ϕ . The shear capacity T_R when the contact is intact is

$$T_R = c \cdot A + N' \cdot \tan \phi_i \quad (4.3)$$

where A is the base area and N' the effective normal force ($N-U$, where U is the uplift force). Note the notation i for internal as this definition is different from that used in guidelines (above).

If the contact is not intact, either due to failure or because it simply never existed, the shear resistance is given by a total friction angle, which is the sum of a base friction angle ϕ_b and a dilatation angle i related to the inclination of larger asperities (length exceeding 5% of the dam height) in the contact surface. Commonly dilatation angles are present, as large man made asperities were deliberately introduced during construction. For this shear stress to develop a relative displacement has to occur. The *shear capacity when the contact is broken* is

$$T_R = N' \cdot \tan(\phi_b + i) \quad (4.4)$$

Failure may thus occur without relative displacement or with relative displacement, and the related failure mechanisms are different. For analysis of the shear strength of a contact that is partially intact Gustafsson et al. recommend that only the intact part is assumed to contribute. This is a conservative assumption, as some shear capacity from the broken contact by base friction and dilatation may be activated, even for these very small displacements.

Gustafsson et al. suggest that for a partially intact surface, only the part of the normal force acting on the area with cohesion will contribute to the shear resistance. The part of the normal force on the part with cohesion is denoted R . The reason for this may be understood if a dam with cohesion only in the upstream part is considered. The normal force is present mostly on the downstream side, hence the shear capacity may be overestimated by not considering R . This is illustrated in Figure 4-7. For a contact which is partially bonded, but where the un-bonded parts are evenly distributed over the whole surface, this assumption may be too conservative. The shear capacity for a partially intact surface may now be written

$$T_R = c \cdot A_c + N' \cdot R \cdot \tan \phi_i \quad (4.5)$$

here A_c is the intact area. Gustafsson et al. (2008) give recommendations for new guidelines for concrete dam sliding stability. For deterministic assessment they propose that (4.4) may be applied to all dams, whereas (4.5) may only be applied to dams of lower consequences. The reason is the large uncertainty related to cohesion.

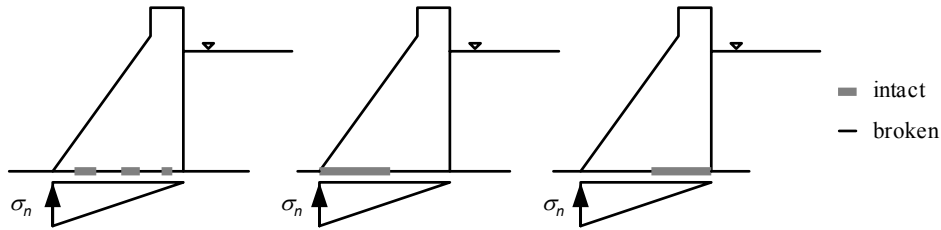


Figure 4-7 - distribution of intact part of contact in relation to normal stress distribution.

4.3.1.2. Sliding in the rock mass

Sliding in the rock mass may occur along joints in the rock mass. Sometimes, persistent joints exist in the rock mass. In other cases, shearing through the rock mass must first occur. According to Gustafsson et al. (2008) the *shear capacity of the rock mass* could be expressed by the Mohr-Coulomb failure criterion as

$$T = c_m \cdot A_{cm} + N' \cdot \tan \phi_m \quad (4.6)$$

where c_m is the cohesion of the rock mass, A_{cm} the intact area of the rock mass and ϕ_m the friction angle of the rock mass.

The *shear strength of joints* is affected by e.g. normal stress, uniaxial compressive strength of the joint surface, surface roughness, weathering of the surface, infilling material and scale (Johansson, 2009 and Bandis et al. 1981).

As the failure envelope is curved, the Mohr-Coulomb failure criterion does not provide a good description of the shear strength of rock joints. This was recognized by Patton in 1966 (Johansson, 2009) who made experiments on “saw-tooth” specimens and proposed a bi-linear failure criterion consisting of two equations. The first part describes the shear strength under low normal effective stresses, σ_n' , when sliding over the asperities occur.

$$\tau_f = \sigma_n' \cdot \tan(\phi_{bj} + i_j) \quad (4.7)$$

where ϕ_{bj} is the basic friction angle and i_j the angle of the “saw-tooth” of the discontinuity.

Under high normal stresses, when shearing occurs through the asperities, Patton proposed the following equation to be used:

$$\tau_f = c_x + \sigma_n' \cdot \tan(\phi_r) \quad (4.8)$$

where c_x is the cohesion when this occurs and ϕ_r is the residual shearing resistance of an initially intact material. The difference between the Mohr-Coulomb and the Patton failure criterion is illustrated by Figure 4-8.

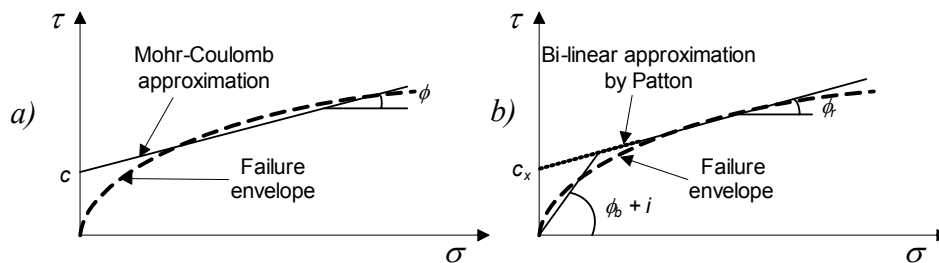


Figure 4-8 - a) Mohr-Coulomb failure criteria. b) Patton failure criteria.

There are a number of other failure criteria for rough unfilled joints, for a summary see Johansson (2009). The level of normal stress is important to determine the shear resistance. For a concrete dam the normal stress is generally small and for this level of stress the failure criterion are, according to Johansson, all built on the same principle: a total friction angle built by two parts, one is constant and depend only on rock type and the other is dependant on normal stress, strength of the joint surface and scale. Gustafsson et al. (2008) propose that equation (4.7) should be used for estimation of shear resistance in shallow joints beneath concrete dams.

4.3.1.3. Sliding in the concrete part

Sliding along lift joints in the concrete may occur. According to Ruggeri et al. (2004) the shear resistance may be described by the Mohr-Coulomb constitutive equation.

According to BBK 04 (2004) the shear strength is a function of the amount of reinforcement, $\rho (=A_{reinforcement}/A$, where A is the total area), through the joint, and the design tensile strength f_{st} of the reinforcement and the lowest compressive stress, σ_{fc} , through the joint. The capacity is also dependant on the roughness of the surfaces and if there are recesses (i.e. large man made asperities). The background of the guidelines in BBK 04 are explained more in detail in Betonghandbok Konstruktion (1990). This is not further discussed here.

4.3.1.4. Limit state functions for sliding

4.3.1.4.1. Along concrete-rock interface

For sliding along the concrete-rock contact two limit state functions are identified. When the contact is intact or partially intact the LSF is based on (4.5):

$$G_1(\mathbf{x}) = c \cdot A_c + N' \cdot R \cdot \tan \phi_i - T \quad (4.9)$$

where c is the cohesion of the interface, A_c is the area with cohesion, N' the effective normal load, R the part of the normal force on the part with cohesion, ϕ_i the internal friction angle and T the load parallel to the failure surface.

When the contact is broken the LSF is based on (4.4):

$$G_2(\mathbf{x}) = N' \cdot \tan(\phi_b + i) - T \quad (4.10)$$

where ϕ_b is the base friction angle and i the dilatation angle due to large-scale asperities. To be able to consider the dilatation angle, it must be ensured that shearing of asperities (intact rock) or shearing through the concrete will not occur, hence the required size is dependant on the load, i.e. the height of the dam.

Sliding along the contact will occur if both limit states 1 and 2 occur. If limit state 1 occurs (i.e. if the intact part of the contact is broken), there is still a possibility that limit state 2 will not occur if the base friction angle and dilatation angle are high. If there is a bonded part, but small in comparison to the whole area the same situation may occur. Limit state 1 and 2 can thus be treated as a parallel system; both have to occur for sliding along the concrete-rock interface and

$$P(G(\mathbf{x})_{slide\ contact}) = P(G_1 < 0) \cap P(G_2 < 0) \quad (4.11)$$

4.3.1.4.2. In the rock mass

For sliding in the rock mass there are also two limit state functions. The first for intact rock, based on (4.6):

$$G(\mathbf{x})_3 = c_m \cdot A_{cm} + N' \cdot \tan \phi_m - T \quad (4.12)$$

where c_m is the cohesion of the intact rock, A_{cm} is the area of the intact rock along the anticipated failure zone and ϕ_m is the internal friction angle of the intact rock. For sliding along a joint in the rock mass the LSF is based on (4.7):

$$G(\mathbf{x})_4 = N' \cdot \tan(\phi_{bj} + i_j) - T \quad (4.13)$$

here ϕ_{bj} is the base friction angle of the joint and i_j the dilatation angle of the joint.

Similar to sliding along the contact, this is also a parallel system

$$P(G(\mathbf{x})_{slide\ rock}) = P(G_3 < 0) \cap P(G_4 < 0) \quad (4.14)$$

Limit state functions are not defined for sliding along concrete joints.

4.3.2 Overstressing

Overstressing will occur if the stresses induced in the dam body or foundation exceeds the material capacity. For buttress dams the front plate (head) will function as a cantilever beam, see Figure 4-4, and one possible failure mode is overstressing of the cantilever beam.

Stresses for the dam body are often calculated based on “beam model” analysis using Navier’s equation:

$$\sigma = \frac{V}{A} \pm \frac{M_c \cdot y_{tp}}{I} \quad (4.15)$$

where V is the vertical force, A the base area, M_c the moment around an axis through the centre of gravity of the base area, y_{tp} the distance from the centre of gravity to the point of interest and I the moment of inertia.

As pointed out by Reinius (1962) the basic requirement behind Navier's equation, that plane cross-sections remain plane, is not fulfilled and larger stress concentrations will therefore occur at the heel and toe of the dam. Stresses from finite element analysis will represent the behaviour more accurately.

It is usually assumed (cracked base analysis) that if tensile stresses calculated by rigid body analysis occur at the dam heel, a crack will form and water will percolate the crack, causing full uplift pressure along the whole crack length.

As pointed out in ICOLD (1993), the concrete to rock interface has tensile strength that, for all practical purposes, is assumed to be zero. This is since joints or fractures may be located directly below the concrete/rock interface and the rock mass will then not be able to develop any tensile capacity (FERC, 2002).

In RIDAS TA (2008) allowable stresses are determined case-specifically and there is no recommendations regarding safety factors.

4.3.2.1. Limit state function for stress

Overstressing in itself is, generally, not a global failure mode. Local crushing or cracking does not necessarily lead to global failure and the failure mechanism will not be "overstressing", but sliding or overturning. Instead overstressing is related to the serviceability limit state and no limit state equation is defined for overstressing. However, overstressing may be the cause and initiating factor leading to global failure and must be analysed, as will be shown below.

4.3.3 Overturning

Overturning may occur if the stabilizing forces, mainly from the self-weight, are less than the overturning forces. The criterion, where used, is usually given as:

$$\frac{M_R}{M_S} > sf \quad (4.16)$$

where sf is the safety factor, M_R is the resisting moment and M_S is the overturning moment. The overturning moments are calculated around the dam toe or some other relevant point, i.e. for lift joints in the dam body or other weak planes.

4.3.3.1. Cracked base analysis

According to RIDAS TA (2008) and several other design guidelines for dams, two criteria shall be fulfilled to ensure the overturning stability; the one described above,

and that “resultant forces fall within the mid third of the base area (normal load case) or within the mid 3/5th of the base area. (exceptional load cases)”.

This criterion actually comes from the “cracked base criteria” mentioned above: if the resultant falls outside the mid third of the base area, tensile forces will occur at the upstream heel of the dam, resulting in full uplift pressure in the cracks thus appearing. This means that the criterion of resultant within the mid third of the base area is, similar to overstressing, not an ultimate limit state.

4.3.3.2. Adjusted overturning

Fishman, in several papers (Fishman 2007, 2008 and 2009), investigate and discuss the failure of concrete retaining structures on rock by literature studies, experimental and numerical work.

A number of different experiments were carried out (Fishman, 2007). Results from those with continuous models of gypsum or concrete (i.e. where the “dam” and foundation are of the same material and cast at the same time, which simulate block-foundation system with strong interface), loaded by a normal force N and a horizontal force at a level h above the foundation, show that

- for low σ_n , a tensile crack starts to propagate from the upstream side. Next the stress concentration on the downstream side increases and, at a shear stress of τ_{cr} , crushing of the foundation on the downstream side begins, resulting in what is referred to as a compressive crack (a thin crack appearing under principal compressive stresses at the compressed side). Increasing the load, the tensile and compressive cracks propagate, from the upstream and downstream sides respectively, until they coalesce at a mean shear stress of τ_{peak} . After this point no further load increase is possible and continued loading results in the formation of a crushing zone, an additional inclination and turning of the shear block and widening of the tensile crack.
- For high σ_n the compressive crack on the downstream side first initiates. Further loading makes the compressive crack propagate and a tensile crack forms at the upstream, propagating downstream. Again they coalesce at a shear stress of τ_{peak} .

Figure 4-9 is taken from Fishman (2007) and show the general behaviour of a test with increasing shear force T . Figure 4-10 shows the result of one of those experiments. The continuous models also showed that the larger the moment created by the shear force T , the lower the peak shear strength for a given crushing resistance R_{cr} .

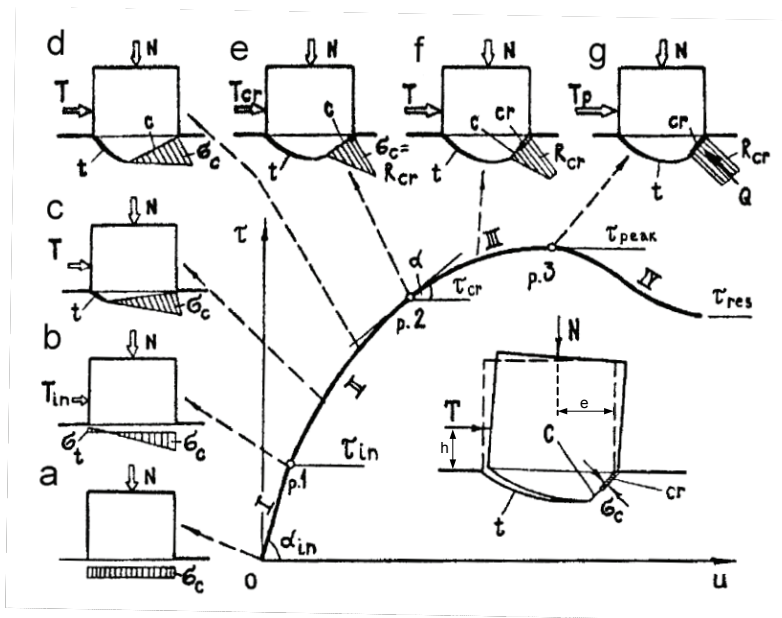


Figure 4-9 – General behaviour of continuous experiment, from Fishman (2007).

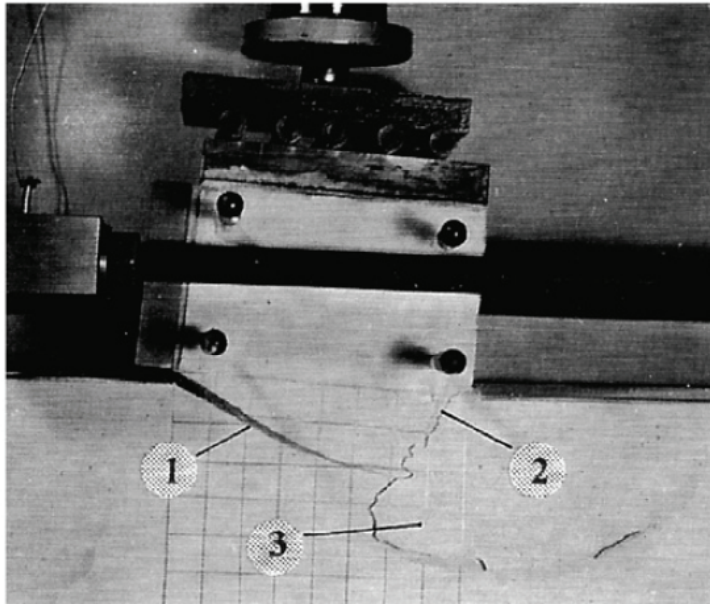


Figure 4-10 – Result of one experiment, from Fishman (2007).

The extreme shear load T_p on the block was found from a solution of the three static equilibrium equations ($\Sigma X=0$, $\Sigma Y=0$; $\Sigma M=0$) to be

$$T_p = \left[(htR_{cr})^2 + 2NetR_{cr} - N^2 \right]^{1/2} - htR_{cr} \quad (4.17)$$

where t is the thickness of the block, e and h are indicated in Figure 4-9, N is the normal force and R_{cr} is the crushing resistance of the rock.

The findings of experimental compound models, where a metal block was placed on a gypsum foundation without an adhesive, is that failure occurred in two ways: either by shear of the block along the contact or by the block turning with formation of deep fracture surface.

Shear failure occurred for low normal stress, while for higher normal stress the turning mode appeared. For low normal stress the ultimate capacity was determined by the Mohr-Coulomb failure criteria, while for higher normal stress the ultimate shear load was possible to describe by the relationship in (4.17). The transition between failure by shear or by turning was identified to occur when

$$\sigma_n > \sigma_n^{crit} = \frac{2R_{cr}(0.5 - m - n \tan \phi)}{1 + \tan^2 \phi} \quad \text{for } c = 0 \quad (4.18)$$

$$\tan \psi > \tan \psi^{crit} = \left[\left(\frac{nR_{cr}}{\sigma_n} \right)^2 + \frac{(1-2m)R_{cr}}{\sigma_n} - 1 \right]^{0.5} - \frac{nR_{cr}}{\sigma_n} \quad \text{For } c \neq 0 \quad (4.19)$$

where c is the cohesion, $m = (0.5-e/b)$ and $n = h/b$, b is the width of the compound model and $\tan \psi = c / \sigma_n + \tan \phi$.

Figure 4-11 show this transition by an abrupt change in shear stress.

According to Fishman (2007) the undesired seepage occurring in foundations of many high dams cannot be explained through shear failure. The turning failure, however, leads to rupture of grouting and drainage curtains and is proposed as the explanation.

From the experimental and analytical results summarized above, Fishman (2007, 2009) propose that the “limit overturning” stability factor

$$F_s = \sum M_r / \sum M_t \quad (4.20)$$

should be calculated. M_r and M_t are the moments of resisting and turning forces relative to the o-axis defined in Figure 4-12 (from Fishman 2007, 2009), the position of which may be found from

$$a = \frac{N}{tR_{cr}} \quad (4.21)$$

$$d = \left(h^2 + 2ae - a^2 \right)^{1/2} - h \quad (4.22)$$

The term “limit overturning” is in this thesis denoted “adjusted overturning”.

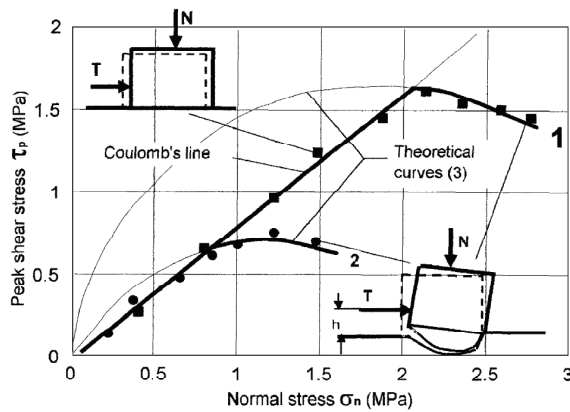


Figure 4-11 - Transition from shear failure to turning failure for 1) low moment created by T and 2) high moment created by T. From Fishman (2007).

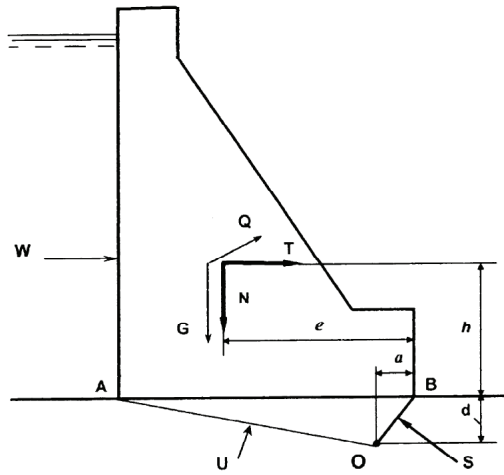


Figure 4-12 - definition of limit overturning from Fishman (2007).

The crushing resistance R_{cr} should best be determined from field tests on sheared blocks using

$$R_{cr} = \frac{N^2 + T_P^2}{2t(eN - hT_P)} \quad (4.23)$$

or it may be approximated by the relationship

$$R_{cr} = 13 \cdot 10^{-4} E$$

where E is the deformation modulus of the rock mass.

The size of the crushing zone is proportional to the strength of the rock. With poorer rock the crushing zone is larger, hence the overturning point is moved towards the upstream side. The adjusted overturning mode is included in the Russian National Construction Code (Fishman, 2007).

As previously mentioned the existence of a “compressive crack” is addressed by Fishman (2008). Still, to prove that this crack was actually formed from purely compressive stresses seem difficult. The final results when it comes to the formation of the failure are, however, not influenced by the compressive crack, hence the results by Fishman are thought to be very important for the limit state formulation for overturning.

4.3.3.3. Limit state function

Following the above description, overturning is considered possible, despite the citation from USACE (2003) “The analysis for determination of the resultant location in prior guidance has been termed an overturning stability analysis. This is a misnomer since a foundation bearing, crushing of the structure toe, and/or sliding failure will occur before the structure overturns”.

However, the overturning point should be chosen so that crushing of rock (and concrete) is not possible. In this way the bearing capacity failure mode is included in the overturning failure mode.

The limit state for overturning is now

$$G(\mathbf{x})_5 = M_R^* - M_S^* \quad (4.24)$$

where M_R^* is the resisting moment and M_S^* is the driving moment, taken around the point * which is determined by the capacity of concrete and rock. The position of this point can be calculated according to the procedure by Fishman.

Crushing of the downstream side will also reduce the shear capacity as the area of cohesion will be smaller and the stress distribution is changed, that may lead to (increased) cracking on the upstream side and higher uplift.

4.3.4 System

From the above discussion on failure modes and definitions of limit state functions, the failure of a concrete dam may occur in the concrete part (as sliding along joints or weak planes, or as adjusted overturning), in the concrete-rock interface (as sliding or as

adjusted overturning) or in the rock (as sliding along joints or through intact rock). In general failure of a concrete dam may thus be viewed as a system according to Figure 4-13.

L in Figure 4-13 refers to the length of the structure relevant for sliding in rock and L_x is the length of the longest joint in the rock mass. If $L - L_x = 0$ a through joint exist.

There may be situations when the above limit state functions are not appropriate, when failure will occur in a different way. The above limit state functions do not account for overtopping leading to scouring of the downstream area. This case may be treated by moving the overturning point to a position where scouring is not expected, similar to the treatment of crushing of concrete or rock.

The series system described above is based on the assumption that each monolith function independently of the others. 3D effects could improve the behaviour in that load distribution from the “weaker” monoliths to stronger would give parallel system behaviour or brittle parallel system behaviour.

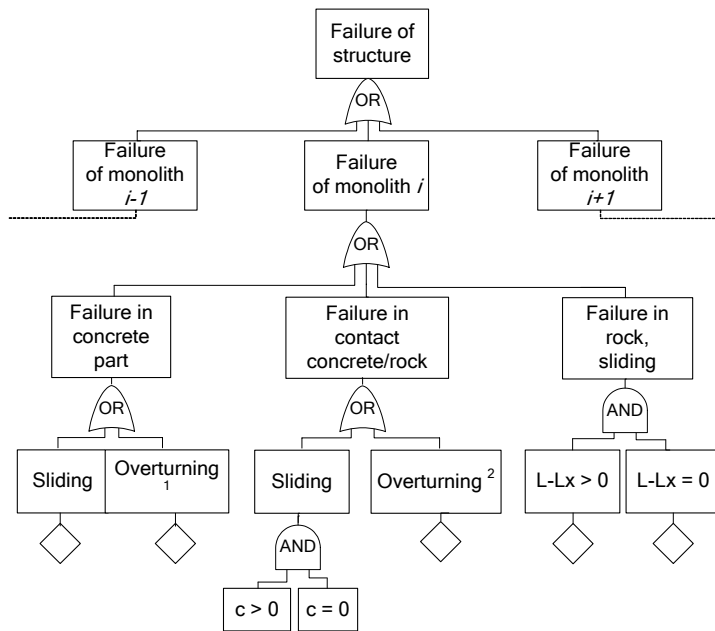


Figure 4-13- System of failure modes for concrete dam. AND gates indicate parallel system (i.e. both failure modes have to occur for failure) and OR gates indicate series system (i.e. failure occur if either one of the failure modes occur). ¹ overturning point determined by concrete crushing resistance, ² overturning point determined by concrete and rock crushing resistance

5. Structural reliability analysis in dam safety

This chapter is related to structural reliability of concrete dams. Target safety index is discussed and a literature survey of papers where structural reliability is applied for concrete dams is given, followed by a short summary of two partial factor design codes for concrete dams. A short discussion of the possible use of structural reliability for concrete dams in the near future is given.

5.1 Target safety index for dams

A risk assessment includes both risk analysis and risk evaluation. The structural reliability analysis can be used to give an estimate of the risk (in terms of the safety index or probability of failure), but for the risk estimation a target safety index is needed.

From the discussion of chapter 2 and 3, different approaches to derive a target safety index can be distinguished, but the only straightforward is that of calibration towards existing practice. Derivation based on tolerable risk, as that shown in Vrijling et al. (1998) may give hints on acceptable levels but is a matter for governmental decisions. As mentioned in chapter 2 the failure probability is nominal, hence when it is used as a measure of the safety against more general societal risk criteria, human error and other effects may have significant influence and the comparison is thus not straightforward.

If the ALARP principle (As Low As Reasonable Practicable, explained in chapter 2) is applied, the target safety index would give the lowest allowable safety index (maximum allowable failure probability) and any further risk reduction would be decided upon based on the ALARP-principle.

As described previously the way to set target safety index for civil structures has been by calibration to existing practice. The target safety values for other structures can not be “just” used for dams, the reasons are that

- The calculated safety index is a nominal one and comparison between components is helpful, but comparison between structures of different types (especially when failure modes and loading conditions differ) may not be correct
- Consequences might not be comparative
- Dam safety risk management is, as pointed out in chapter 2 to larger extent than other civil structures affected by value judgement (company and societal values) and this should be reflected.

Based on calibration and judgement by experts, the target reliability index of bearing capacity of concrete gravity dams and reinforced concrete hydraulic structures are listed in “The standards compilation of water power in China” (China Electricity Council, 2000), shown in Table 5-1. It is, however, not defined what reference period this table refers to. A reference period of 100 years for Grade I structures and 50 years for Grade

II and III is mentioned. Use of (3.42) (EN1990) then gives $\beta_T = 4.75$ for the first type of failure and $\beta_T = 5.15$ for the second type of failure of grade I structures based on a reference period of 1 year.

As pointed out in ICOLD (2005), comparisons between risk tolerability in different countries are not straightforward. “Since the risk evaluation stage is where societal, regulatory, legal, owners and other values and value judgements enter the decision process it should not be surprising that country to country variations, and indeed within country variations, will be more evident in risk evaluation than in any other risk assessment process” (ICOLD bulletin 130, 2005). This means that the target safety index from Table 5-1 can not be immediately used for Swedish conditions.

Table 5-1 - Target safety index given in (China Electricity Council, 2000).

Safety grade of structures		Grade III	Grade II	Grade I (highest importance/conseq. of failure)
Type of failure	First type (failure with "warning")	2,7	3,2	3,7
	Second type (sudden failure without apparent signs)	3,2	3,7	4,2

If a target value is to be specified for dams a broad discussion among government and dam owners is necessary. It must be pointed out that the setting of a target safety value should not be performed by engineers alone, but economists, politicians and social scientists should also be involved. There are a number of questions that need be discussed: Is the target value to be calibrated to existing practice? Is it to be based on societal values as well? Are new dams (or parts of dams) supposed to have higher safety index than existing ones? Are dams to be separated into different consequence classes (as in RIDAS) with different target safety indices?

But perhaps the setting of a target does not have to be very complicated: RIDAS is today used as a guideline and dams fulfilling the safety “requirements” are considered “safe enough”. This means that they should be considered safe even by use of structural reliability analysis, and thus a target safety index can be derived.

5.1.1 Calibration of target safety index

An attempt to derive target safety index for Swedish dams has been performed as a master’s thesis by undergraduate students Jill Holmberg and Lucas Ahlsén under supervision by Marie Westberg, Ahlsén Farell & Holmberg (2007).

The procedure was to

- Choose “typical” dam structures. Based on some data from Vattenfall “typical” dimensions of gravity and buttress dams were chosen. Gravity dams were defined to have a crest of certain width, the downstream side was considered to have a slope of 50 degrees and two types of buttress dams (one with vertical and one with inclined front) were tested. All dams were considered to have a

freeboard of 1.3-1.7 m (depending on height). The geometries are indicated in Figure 5-1 below.

- Design according to current practice. RIDAS application guideline was used to set the requirements. A dam with certain dimensions (height, crest width, etc) was given a width so that the safety factors of RIDAS (sliding and overturning) were fulfilled.
- Define basic random variables. This is the most difficult part, as the information is scarce. Also this is the most important part as the input affects the safety index. Sensitivity analysis of the basic variables was performed, but for the most part the basic variables are taken according to that shown in Westberg (2007). For exact information, see Ahlsén Farell & Holmberg (2007).
- Calculate the safety index. This was done using the computer software COMREL (RCP, 1997).

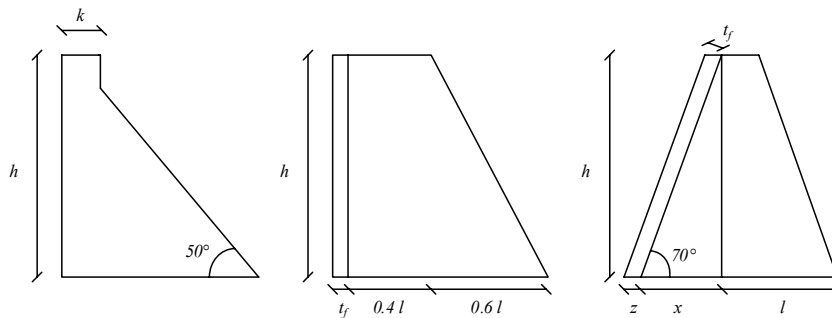


Figure 5-1 – Geometry of concrete gravity dam and two types of buttress dams.

The results indicate that for gravity dams the safety index (thus safety) decreases with increasing height as shown in Figure 5-2, whereas the safety of buttress dams increases with increasing height in case of overturning and decreases in case of sliding. The failure modes considered were sliding and overturning, and this might be questioned. In the sliding case cohesion was taken into account (even though this is not considered in RIDAS). The results indicate that the current guideline does not result in a uniform safety level.

The analysis of the results is all but simple, as many factors come into play. Here only some short notes are summarized:

- For the overturning of a gravity dam the chosen geometry has impact. When the same calculations were performed for a triangular-shaped geometry, the result is a more uniform overturning stability. However, completely triangular-shaped dams does not exist, which indicates that the design guideline is not very well fitted for “typical” dams.
- Sliding of a gravity dam is heavily influenced by the cohesion, in this case $c \sim \text{LN}(1.3; 0.9)$ was assumed. As cohesion is not taken into account in RIDAS, a

triangular-shaped geometry without cohesion gives a steady safety level with $\beta = 1.5-1.4$ (for $h = 15-30$ m), whereas if cohesion is taken into account the same geometry gives $\beta = 7.6-6.2$ for the same heights, i.e. decreasing with height (not shown in the below figure). This is since the base area (at which the cohesion is active) increases by only a factor of 2, while the vertical and horizontal forces increases with a factor of 4. If the “safe” dams had safety index of only 1.4 (corresponding to approximately $p_f = 0.07$, i.e. extremely high) they would have to be rebuilt and we would probably have seen dam failures due to sliding.

- For buttress dams the explanation of the sliding case is the same as for gravity dams.

Non-uniformity of the safety level of guidelines means that resources are likely to be used inefficiently – if the design code implies that a structure is unsafe, when in fact it is safe enough, and remedial works are performed, that would have better been spent on another structure, which might have in fact been deemed safe according to the code, but was not.

More information of procedure, input data and findings are given in Ahlsén Farell & Holmberg (2007).

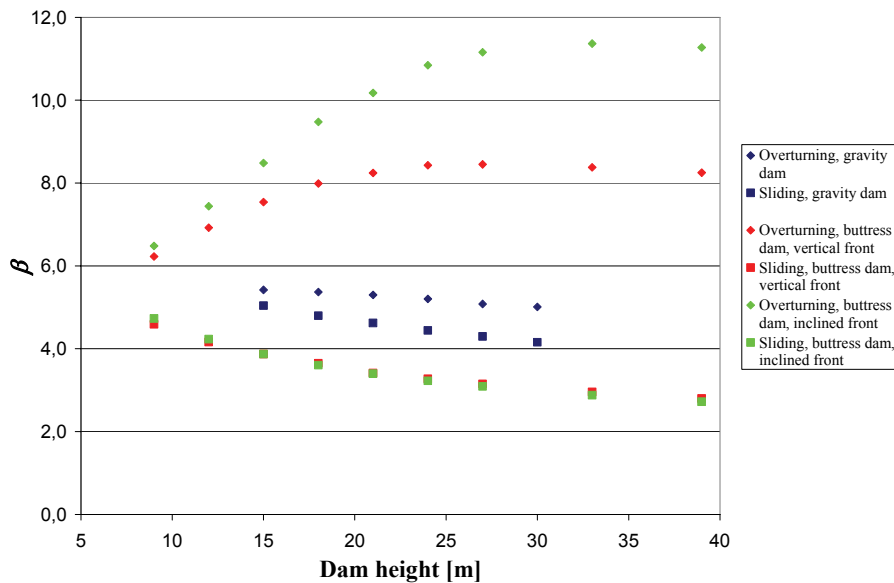


Figure 5-2 - β as function of dam height. Overturning and sliding of gravity dam, buttress dam with vertical front plate and buttress dam with inclined front plate.

5.2 Previous work on structural reliability analysis of concrete dams

The following section aims at summarizing what has been done in the field of structural reliability analysis for concrete dams. The amount of work in this area is, as will be seen, not very large. The presented papers are what have been found in this area, with one or two exceptions of things that could not be retrieved. The interest seems to be increasing with four papers presented in 2009. Table 5-2 shows some information of the papers and further details are given in the below summary, where focus is on limit state functions, models and input data rather than the resulting safety index. The reason is that results are highly case specific and, whereas the limit state functions, models and input data are more general.

Table 5-2 - Summary of papers on structural reliability of concrete dams. Full prob. = overall safety index, fragility curve = p_f presented as a fragility curves.

Authors	Year	Rigid body	FE	Seis-mic	Full prob.	Fragility curve	In data from tests	Focus
Bury & Kreuzer	1985	x		x	x		Partly	Show method
Baylousis & Bennett	1989	x		x	x		Partly	Show method
Ajaújo & Awruch	1998		x	x	x		Partly	Finite element analysis and show method
Ellingwood & Tekie	2001	x	x	x		x	Upper & lower bounds, uniform dist.	FE-model + fragility, show method
Tekie & Ellingwood	2003		x	x		x	Partly, mostly eng. judgement	FE-model + fragility, show method
Jeppsson	2003	x			x		Partly	Show the method
Saouma	2006		x	x	x		For fracture energy	Demonstrate method applied to fracture mechanics
Carvajal et al.	2007	x			x		For flood + shear strength	Show method + develop for guideline purpose
Lupoi & Callari	2009		x	x		x	Partly	Show method and discuss why not used more
Royet et al.	2009	x			x		For flood + shear strength	Show method + develop for guideline purpose
Krüger et al.	2009	x			x		No. Published data + dam safety review documents	Show method and discuss why not used more
Altarejos et al.	2009	x			x		Partly	Show method and discuss why not used more

1. *Bury & Kreuzer (1985)* made a rigid body analysis of a concrete gravity dam. The authors state that all feasible failure mechanisms must be identified, modelled & processed. In this paper only sliding was considered for the purpose of showing the method. Bury & Kreuzer are of the opinion that failure-causing loads for dams are rare events, essentially independent of one another, thus can be analysed separately. The worst-case scenarios in this case were identified as

1. The annual flood volume causing overtopping and scouring of the dam toe (decreasing the sliding resistance, modelled in this case as loss of a part of the dam toe + area of cohesion due to formation of a tension crack). The flood peak Q was modelled as a Gumbel distribution (m^3/s). Q is then converted to hydrostatic head, giving the load.
2. The earthquake acceleration, increasing the load on the dam (horizontal ground motion) and decreasing the resistance (vertical ground motion). The ground acceleration was also modelled as a Gumbel distribution and the number of earthquakes is modelled as a Poisson distribution. $P(1 \text{ or more EQ in one year}) = 0.54$.

Mean values and standard deviation of cohesion and friction angle were based on past experience and both were modelled by normal distributions. The non-normal distributions (Gumbel) were approximated by a normal distribution in the upper tail and thus p_f could be calculated. p_f was higher for earthquake load than for flood conditions.

By expressing parameter uncertainties in terms of normal distributions the uncertainty in p_f (second order uncertainty) can be explored. A maximum likelihood analysis of flood data gave $\Delta\mu$ and $\Delta\sigma$, which in turn gave $\mu_Q \sim N(\mu_Q, \Delta\mu)$ and $\sigma_Q \sim N(\sigma_Q, \Delta\sigma)$. Similar analyses were done on the resistance side and for the earthquake ground motion.

The results of the parameter uncertainty investigation showed that the upper 75% confidence limit on p_f (i.e. p_f when the second order uncertainty is included) was one order of magnitude larger than the original p_f , both for flood and earthquake.

The conclusions were that:

- The results indicated that caution should be taken in the use of p_f for consequence analysis
- For the flood the largest uncertainty lies in the model of how to get the load, knowing Q .
- For the earthquake the uncertainties relate to the database.
- Friction angle and cohesion influence the result far more than other parameters.
- “It seems also clear, in view of the expected inaccuracy in p_f , that neither greater sophistication in the failure model nor numerical integration of the interference integral are warranted in practice. A simple failure model and a simply obtained, approximate p_f -value appear justified unless the uncertainties in information inputs can be greatly reduced.”

2. *Bayliss & Bennett (1989)* evaluated the safety and probability of failure of an existing 146 m high gravity dam subjected to normal static loads and dynamic loads from earthquake. The failure modes analysed were sliding, overturning and overstressing. Two reservoir water levels were assumed; as a random variable ($hw \sim N(122.7; 10.1)$) and head water at the level expected in a flood situation. Earthquake acceleration time history records from a nearby power plant were used and thermal analysis based on measured temperature readings. The overall probability of failure was the conditional probability of failure multiplied by the probability of occurrence of a flood (0.00025/year) and the probability of occurrence of an earthquake (0.0001/year).

The results show that the static load combinations give negligible probabilities of failure, despite the fact that the factor of safety against sliding and overturning are significantly different. The probability of sliding during an earthquake is also negligible. The critical modes are overturning and overstressing during an earthquake. The conditional probability of failure was greater with the reservoir at the flood level, but due to the small likelihood of both a flood and earthquake, the overall annual probability of failure is greater for a random reservoir level.

3. *Ajaújo and Awruch (1998)* made a probabilistic finite element analysis of concrete gravity dams subject to seismic excitation. The expected value of safety factors, and the standard deviation of the safety factors and safety index (β) was calculated by 50 Monte Carlo simulations.

4. *Ellingwood & Tekie (2001)* made a rigid body analysis and a FE analysis of a dam for the limit states

1. Resultant outside of kern (rigid body) or tension of the heel (FEA*)
2. Resultant outside of middle half of base of dam
3. Resultant outside of the base of dam
4. Pool elevation above the top height of the dam
5. Material failure – foundation or concrete (at the toe)
6. Sliding failure at the dam-foundation interface
7. Material failure at the neck of the dam (FEA*)
8. Deflection of the top of dam relative to heel > 0.1 m (FEA*)

* indicate that only a FE-analysis was made for these limit states.

Uniform statistical distributions were used for drain effectiveness, grout curtain effectiveness, tail water elevation, effective uplift area, angle of friction, cohesion,

compressive strength of intact rock and a normal distribution for concrete compressive strength.

The rigid body analysis was performed to provide a benchmark for the FE analysis. The results show that only limit states 1, 2 and 4 (overtopping) occurred for the range of pool elevations analysed. The probability of achieving limit state at the original design pool elevation is very small.

The results are presented as fragility curves, i.e. the conditional probability of failure, and each limit state probability can be expressed as

$$P[LS] = \sum P[LS|Y = y]P[Y = y]$$

in which $P[Y = y]$ = hazard, expressed in terms of annual probability and $P[LS | Y = y]$ = conditional probability of structural failure, given that $Y = y$. This expression allows the overall risk to be deconstructed into its significant hazard contributors.

Hydrologic fragility of a concrete gravity dam displays the probability that the dam reaches a limit state of acceptable performance, conditioned on the occurrence of a particular value, y , of some random hydrologic demand, Y .

A lognormal distribution was found to fit the fragilities well, and this is also what may be expected in many cases. The largest sensitivity was for effective uplift area, followed by drain and grout curtain efficiencies.

The motive for Ellingwood & Tekie to perform a FE-analysis is explained by the following citation: “Several stages (limit states) of dam behaviour occur under progressively increasing levels of flood. At low levels, the dam-foundation system remains essentially elastic, displacements are small, drains are fully effective, and full control of the reservoir is maintained. The traditional 2D equilibrium analysis of the dam as a rigid body is sufficient. At the onset of non-linear behaviour, material cracking occurs, deformations may become permanent, drainage characteristics of the dam and the operation of gates begin to be affected, and 3D structural actions within the dam are initiated. At this stage, 2D rigid body analysis of a dam monolith may no longer provide a good model of structural action, and a finite element model may become necessary. Finally, at ultimate conditions prior to impending failure, the drains are ineffective due to large deformations, and structural behaviour becomes unstable and unpredictable due to sliding, flotation, or loss of foundation material bearing capacity. In extreme cases, loss of control of the reservoir may occur. Structural and geotechnical issues are interlocked in understanding the mechanics of how dam failure develops. “

A separate FEA was carried out to determine the uplift pressure distribution at the concrete-rock interface. Grout was considered by assuming a very low permeability relative to the surrounding rock. The uplift obtained compare well with other results. A number of deterministic FE-analyses showed that the stresses from the rigid body analysis compared well with those from the FE-analysis and also that the deformations of the top were very small. This indicates that the dam will behave like a rigid body in this case. For LS1 fragility curves are given for tension in at least one element and for at least two elements. The fragility curve of the rigid body analysis falls between these two

curves. The rigid body fragility curve exhibits larger variability than the FE fragility curves.

5. *Tekie & Ellingwood (2003)* made a seismic fragility assessment of a concrete dam (the same dam as they analysed in their 2001 paper). Commercial FE code Abaqus was used for the non-linear analysis and the limit states analyzed no 5-8 above (in their 2001 paper). Latin Hypercube sampling technique was adopted to minimize the cost of FE analyses required to develop the fragility curves. For each set of random variables the fragility of twelve ground motions (0-1.2 g, 1,2 g corresponding approximately to the acceleration of an earthquake of return period 12 000 years). Input data was the same as in their 2001 paper and the water level was constant at the most likely pool elevation (that necessary to drive all five turbines). The analysis showed that the overall deformations are in the order of 0.02% of the height of the dam, suggesting that a rigid body model might be an appropriate simplification of the problem, provided that one is not interested in LS 7. The results are fragility curves. The 5th percentile fragility of the limit states is presented (i.e. the ground motion that will not (with 95% certainty) cause limit state violation), e.g. the 5 percentile of a sliding of 0.1 inch is 0.52g, that of sliding of 6 inch is 1.02 g. The probability of limit state violation in case of a ground motion of 1g is also presented (100 % and 4 % for sliding of 0.1 inch and 6 inch, respectively). Tekie & Ellingwood consider that such quantitative measures of performance provide perspectives on decisions regarding rehabilitation and retrofit and can support the development of risk management policies for concrete gravity dams

6. *Jeppsson (2003)* made a safety assessment of a monolith of an existing spillway monolith using both the current Swedish deterministic guideline and reliability analysis. The limit states analysed was overturning and sliding (without cohesion) and the dam was safe for overturning, whereas for sliding the safety was not sufficient. Uplift monitoring results were incorporated in the analysis and the safety index for sliding was then increased to an acceptable level. Input data was based on translation from characteristic values using engineering judgment and monitoring.

7. *Saouma (2006)* demonstrate how reliability index calculations through point estimate method & Taylor's series finite difference estimation can be coupled with non-linear finite element fracture mechanics to determine the safety index β after rehabilitation. A dam in need of rehabilitation (increase of design flood) was analysed. The only source of non-linearity was the rock-concrete interface and the uplift pressure.

In case of cracking at the heel of the dam, full uplift was applied in the crack.

Linear elastic fracture mechanics (LEFM) was used for analysis of the original dam and NLFM was used for the retrofitted one. Density of concrete and E-modulus of concrete were taken as constant values, while pool elevation, fracture toughness, cohesion and friction angle were taken as normally distributed variables, with realistic mean value and standard deviation according to engineering judgement. The results showed that the

original dam was unsafe with low β and that the retrofitted one was safe with high β . Comparison however is not possible since input data and analysis type (LEFM/NLFM) is changed. Another conclusion is that the fracture energy was not important and that the two reliability methods tested gave different results, which the author interpreted as an indication of some limitations of the methods, perhaps because the failure design space was not sufficiently represented and the probabilities relate to rare events.

8. *Carvajal et al. (2007)* made a reliability analysis of a gravity RCC-dam. The hydraulic loads (i.e. head water level is received from an approach where

- a) The initial head water level in the beginning of the flood event is taken into consideration (from statistical analysis of monitoring) and
- b) Flood frequency is estimated by Simulated Hydrographs for flood Probability Estimation (SHYPRE) which combines a stochastic model for generating hourly rainfall with a model that transforms rainfall runoff into discharge.
- c) Rainfall events (from SHYPRE) are generated for each simulated year. Each event is associated with an initial head water level. Flood levels are evaluated taking into account the capacity of the spillways. A frequency distribution is evaluated for maximum floods.

The shear parameters are evaluated using an intrinsic curve formula and the variability is evaluated from variability of compressive and tensile strength.

The limit state functions analysed was sliding and cracking. The reliability analysis was performed by Monte Carlo simulation and FORM. The P_f received was lower than 10^{-7} for sliding, $6.4 \cdot 10^{-5} / 7 \cdot 10^{-5}$ for cracking (MCS/FORM) and $1 \cdot 10^{-5} / 9.2 \cdot 10^{-6}$ for shearing coupled with cracking.

A research project continues on characterization of the spatial and temporal variability of the strength parameters in the body of the dam, in the contact zone and inside the foundation.

9. *Lupoi & Callari (2009)* use probabilistic FE-analysis for seismic assessment of existing dams, to effectively manage uncertainties regarding structural data and external actions and to account for several potential failure mechanisms. For seismic analysis the behaviour of the reservoir water is of importance for the dynamic response of the system, thus at least three components are of importance: dam body, foundation rock mass and reservoir water. Lupoi et al. find it surprisingly that the assessment of dam structures is still carried out in professional practice in a deterministic fashion, largely employing empirically based methods. The paper presents the application of a probabilistic method based on the approach developed for building and bridge structures for dams. A two-dimensional finite element model was used to find the response of the analysed dam for seismic events relative to an operational limit state. Numerical simulations were carried out for a limited number of recorded ground motions and water reservoir levels (y_i) and responses of the dam were calculated for mean values of

capacity (\mathbf{x}_i) and the response-gradients (demand with respect to random structural properties) were evaluated. Then a plain Monte Carlo simulation (now simple and computationally inexpensive, since it did not require any structural analysis) was carried out to get the conditional exceedance probability $P_f(\mathbf{y}_i)$. Complete vulnerability curves were obtained by repeating this for a number of \mathbf{y}_i . Since this study was on the operational level, the failure modes identified were:

1. Excessive deformation of the dam body, inducing service limitation for equipments and installations
2. Cracking or sliding at dam base
3. Cracking at the dam neck
4. Cracking at the upstream face.

Results were presented as fragility curves for different levels of head water, P_f thus being a function of the ground motion. Depending on the definition of cracking at the base, the results differ. If cracking is assumed when one node cracks, this failure is the most probable. If cracking is taken as the failure of three contiguous nodes, cracking is no longer the most probable failure mode. The overall effects on P_f due to structural uncertainties are negligible in this analysis, partially explained by the uniform variability of material properties and linear material behaviour assumed.

10. Royet *et al.* (2009) describes the French guidelines for concrete dams in FRCOLD. These are discussed in section 5.3.

The paper also describes the research project described in Carvajal *et al.* (2006).

11. Krüger *et al.* (2009) made a reliability analysis for a gravity dam. The limit states investigated were tension/crushing and stresses were calculated based on Navier's formula. The Bootstrap-method was applied to the reliability bounds for the safety index. Some mistakes in the description of different methods for reliability were however made.

12. Altarejos *et al.* (2009) estimated the probability of failure against sliding along the dam-foundation contact plane for different water levels. The analysis was based on a two-dimensional limit equilibrium Mohr-Coulomb criteria and input data were assigned based on dam safety review documents and published data. Second moment method (level 2) was compared to Monte Carlo analysis (level 3). The results show that

- Cohesion and friction angle are the most important variables, and an analysis where those two were the only random variables gave similar results as the analysis where 10 parameters were random.
- The level 2 method overestimated p_f by an order of magnitude.

The authors state that “in the risk analysis environment, limit equilibrium models offer a useful tool as statistical reliability-based methods match very well with them. As knowledge of parameters influencing the behaviour of the dam increases, the use of more complex models becomes justified. In fact, outside risk analysis, a strong degree of complexity has been achieved in last decades involving numerical models (finite element and finite difference with large number of elements), fracture mechanics, fully non linear dynamic analysis and so on. “

To sum up, the attempts so far may be divided into simple rigid body analysis (Bury & Kreuzer, Bayliss & Bennett, Ellingwood & Tekie, Jeppsson, Carvajal et al., Royet et al., Krüger et al. and Altarejos et al.) and more advanced finite element analysis (Ellingwood & Tekie, Tekie & Ellingwood, Saouma, Lupoi & Callari). The above papers present very important research that will help improve stability analysis for concrete dams. The recent results presented in ICOLD indicate more focus and interest in this approach in recent years.

One problem, however, is that a lot of focus has been put in very advanced methods, but less effort is put on a reliable and sound estimation of the input parameters. As pointed out by Kreuzer & Bury, the uncertainty in input data is of major importance for the resulting failure probability.

For a reliable result, both model and input data must be of good quality. An advanced analysis based on guesses of input data will produce results that are of little use, as will a bad model with good input data. A balance between the two is necessary for practical use to get reliable results.

For many applications a rigid body analysis is likely to be sufficiently accurate, with obvious exceptions for extensive cracking or when 3D effects are large. In seismic analysis stochastic FE-analysis may be necessary, even though the analysis by Tekie & Ellingwood suggested that a rigid body analysis would have been sufficient.

As Altarejos et al. (2009) put it: “As risk analysis techniques evolve in time, become more familiar to users, and their results are applied by dam owners, the need to step beyond the simple limit equilibrium methods for better estimation of failure probabilities will arise. In particular, problems related to cracking on dam-foundation contact plane, can be faced with relatively simple tension-based criteria or with more complex fracture mechanics concepts. Better estimation of stress levels acting on the base of the dam can be achieved with models based on a deformable body approach, starting with the simplest linear elastic constitutive model for a dam and foundation in combination with the well-known Mohr-Coulomb model for the interface”.

5.3 Partial factor design guidelines for concrete dams

Most design guidelines related to concrete dams are based on a deterministic analysis, only two exceptions have been found: China Electricity Council (2000) (will be abbreviated CEC in the following part) and FRCOLD (2006). It is not known how these guidelines are used, but it is known that in China there are different guidelines

depending on main purpose of the project (mainly hydropower or mainly water irrigation).

Table 5-3 shows a comparison between those guidelines.

Common for both CEC and FRCOLD is

- The partial factor format (see section 3.5).
- Load classification.
- Load combinations.
- Characteristic values of load and resistance shall be used to calculate the load effect.

The limit state functions are similar, but in CEC limit state functions are divided into those related to bearing capacity (comparable to ultimate limit state) and those for normal operation (comparable to serviceability limit state). In FRCOLD no such distinction is made, but the limit state related to cracking of the interface/dam body might belong to the serviceability limit state rather than the ultimate limit state.

When it comes to target safety, no such is defined in FRCOLD. The partial factors are taken from literature and semi-probabilistic design guidelines in the civil engineering field. They would normally be calibrated in such a way that the structure will have a safety level above the target safety index. CEC on the other hand, describes the calibration procedure to define the target safety index (see section 3.6.2) and defines partial coefficients according to the same procedure as e.g. NKB 55E (1987) that is the basis for BKR (2003).

Partial factors are only defined for resistance parameters in FRCOLD. The reason is that the hydrostatic load is defined for different return periods or for different operational conditions and hence known with certainty for the different load combinations analysed. The seismic load is only applied in the accidental LS (no partial factor defined) and the ice load is only present in very special cases (not defined). The only remaining load is the uplift pressure, which is considered to be known for a defined level of water, hence no partial factors are considered to be necessary.

Another big difference is in the definition of characteristic values. In FRCOLD a characteristic values is a “cautious estimate”, or, where possible, the 0.05 fractile of the statistical distribution. The following is from Royet et al. (2009), (giving some introduction to FRCOLD), “in dam engineering, the use of statistical methods is not always relevant. Cautious estimating then has recourse to expert judgment, working from available test results or from guidance values found in the literature. The characteristic value then represents a cautious expert’s estimate of the value of the strength of the material, responsible for the appearance of limit states. Some authors have attempted to translate expert prudence as 90% fractile = “highly improbable”, 99 % fractile = “almost impossible” (Hartford & Baecher, 2004)”. In CEC on the other hand, characteristic values should be taken from tests or are defined in tables for different classification of rock and soil (hence are considered possible to estimate).

The method to identify partial factors described in FRCOLD is one possibility. However, since no probabilistic analysis has been made, no systematic analysis of the inherent uncertainties was performed. Instead the partial factors are related to other types structures (and possibly materials) than those they are applied to. In general, partial factors on the resistance side are associated with partial factors on the load side, hence the safety level may not be the same if partial factors are transmitted from one application to another. A better procedure would that used in CEC and NKB 55E (1987): to calculate the safety index for a number of structures that are considered safe according to the deterministic guideline and define the target safety from this. The partial factors are then calibrated for “common structures” from the target safety, based on sensitivity values and due to their inherent randomness.

The choice in FRCOLD not to assign partial factors on the loads is justified by the hydrostatic load to be known. Uplift pressure is a function of the hydrostatic pressure. The assumption in FRCOLD that the uplift pressure does not have any deviation compared to the design assumption is not considered reasonable, hence a partial factor related to uplift should be introduced. Earth pressure is also not assigned a partial factor, but as the uncertainties in earth pressure in terms of coefficient of pressure at rest and density may be large, a partial factor should be applied. In the safety format chosen, see eqn. 3.39 in section 3.5.1, it is common practice to assign partial factors to all variables, although in some cases this partial factor may equal one.

The assignment of characteristic values for concrete dams is associated with many obstacles and is by no means an easy task. Relying on “cautious estimates” is, however, not in accordance with the safety format described in Eurocode (EN1990, 2004).

These FRCOLD guidelines may be considered a good first step in the direction of a semi-probabilistic guideline for concrete dams. There are very good points in defining load combinations and design situations, but further work remains. The CEC guidelines are considered good, but are not possible to use directly for Swedish conditions due to target safety, load and resistance parameter definition.

These two guidelines, however, indicate that a semi-probabilistic partial factor design is possible to implement for concrete dams, even though there are several obstacles involved in the process.

Table 5-3 - Comparison between Chinese Electricity Council (2000) and FRCOLD (2006). wl = water level, y = year

	CEC	FRCOLD
Load classification	Permanent (G, E, P, Si), Variable (H, W, Pe, U, F, Te, Si, Ic, Fh, Gr, Li, Se), Occasional (Se)	Permanent (G, E, P, Si), Variable (H, U, Ic), Accidental (Se)
Design situations	Sustained (normal wl , high wl for flood control, ice condition), Transient (temporary wl during construction period), Occasional (Checked flood wl , seismic condition)	Permanent operational situations, Transient (wl during design flood (1000-10000 y return period, empty reservoir), Accidental (flood of return period > 10 000 y, seismic). Transient/accidental may also be: spillway gate malfunction, debris/ice jam blocking spillways, drainage pump failure, uplift pressure relief system failure, drainage system failure, loss of water tightness of upstream facing...
Limit state functions	1. Load bearing capacity: strength of dam body & foundation, sliding along interface, along lift joints in the dam body or in the foundation. 2. Normal operation: tensile stress at heel/upstream face	Cracking of dam body or interface, sliding (shear) in dam body lift joint, in interface or in foundation, lack of compressive strength in dam body or interface
Target safety	Yes. Depending on type of structure and type of failure. Calibration procedure to get target reliability is explained in 3.6.2.	Not defined
Characteristic values	Defined for all loads and resistance parameters. For resistance parameters it is the 0.05 fractile for synthetic materials, 0,2 for surrounding rock and foundation and 0.1 for earth and rock material and soil foundation. *	0.05 fractile where possible, otherwise a "cautious" estimate
Partial coefficients	Defined for all loads and resistance parameters.	Defined for resistance parameters only, from literature.

G = self weight, E = earth pressure, P = pre-stress, H = hydrostatic pressure, W = wave pressure, Pe = seepage pressure, U = uplift pressure, Fl = flow, Te = temperature, Si = sediment pressure, Ic = ice, Fh = frost heave, Gr = grouting pressure, Li = transient live load, Se = seismic

* = resistance: statistic parameters and probability distribution models should be defined according to data of specimens or tests in-situ for each project. If the data is insufficient, these may be defined according to the classifications of rocks and soils using data of the same sort of soils and rock masses in other projects.

5.4 Structural reliability in dam safety in the near future

Until further development in this area states differently, the routine risk and safety assessment should preferably be carried on as presently done, using deterministic approach (safety factors). When a dam does not fulfil performance goals and a more detailed risk and safety assessment process is initiated the use of structural reliability analysis is advantageous. The use of object specific information in the analysis gives more exact information of the performance, resistance and actions and may be used to calculate the safety index of that specific structure. The process can be illustrated as shown in Figure 5-3, where, first, an assessment is performed based on the present design guidelines and, secondly, if the required safety level is not fulfilled, structural reliability analysis is used in the assessment. Comparison to a target safety index will then answer the question “is it safe enough?”. Questions regarding target safety index and probabilistic descriptions of loads have to be solved before it can be used in practice.

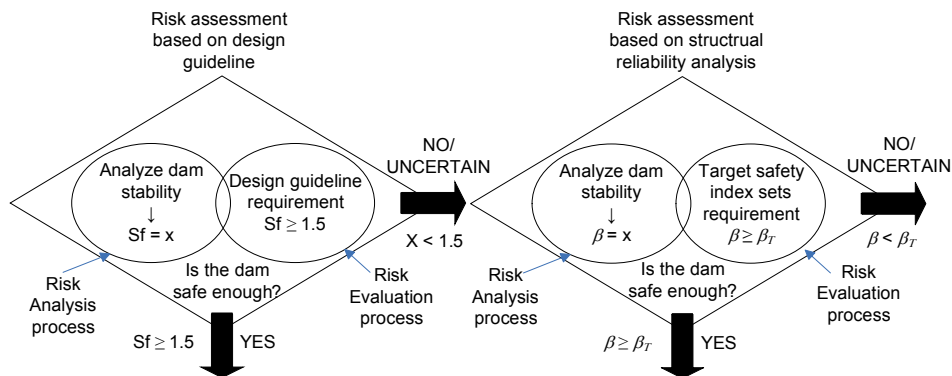


Figure 5-3 - Assessment procedure.

Some of the benefits of a reliability based assessment method are that the applications may be mentioned:

1. Calibration of partial factors for design model based on partial factor-design.
2. Design of more complex structures and structures where larger/smaller target safety (than according to design guideline) is required.
3. Use in analysis of a specific dam. When safety according to the design guideline (deterministic/semi-probabilistic) is insufficient, use of monitoring result, “proof-loading” (i.e. that a dam has survived for 40 years) etc can be used for thorough analysis of a structure.
4. Input to quantitative risk analysis or assessment.
5. Prioritization of remedial works

6. Identify main sources of uncertainty (which loads are most important for an “unsafe” condition) in order to focus remedial works where it gives the best results.

Hopefully calibration of partial factors for design model based on partial factor-design may be done quite soon. There are some areas where research is needed before this is possible (e.g. better model and knowledge of shear strength). The next step after defining this would be to perform reliability analysis of a number of “typical” structures in order to investigate the possibility of such calibration. Since each dam is unique, partial factors may become too large (to cover all possibilities) and in such case a reliability based design concept for more complex structures would be advisable. If attention is paid to this area it should be possible to investigate this and define a functioning methodology quite soon. What is needed for this is

- A group of qualified people (knowledge on stability assessment/design and reliability analysis for dams and if possible of calibration (in another area))
- Definition of input data
- Analysis of a number of objects
- Decision on how to determine the target safety index.

Points 3, 4, 5 and 6 may to some extent be done today, but some more research is needed for a fully functioning methodology.

As seen from the literature survey in this area above, it is also possible to combine a structural reliability analysis with a Finite Element analysis. This provides the possibility of very advanced investigations and should be further developed. In many cases a rigid body analysis is sufficient, but for complex structures where non-linear effects such as cracking occur finite element analysis is the only possibility.

6. Random variables

In this chapter, definition of random variables related to the previously defined limit state functions are considered.

In the last section the system of failure modes for a general concrete dam is presented.

In chapter 4, limit state functions and system for a concrete dam were identified. The main parameters contributing to the resistance of a concrete dam, as well as the main loads affecting the dam are shown schematically in Figure 6-1.

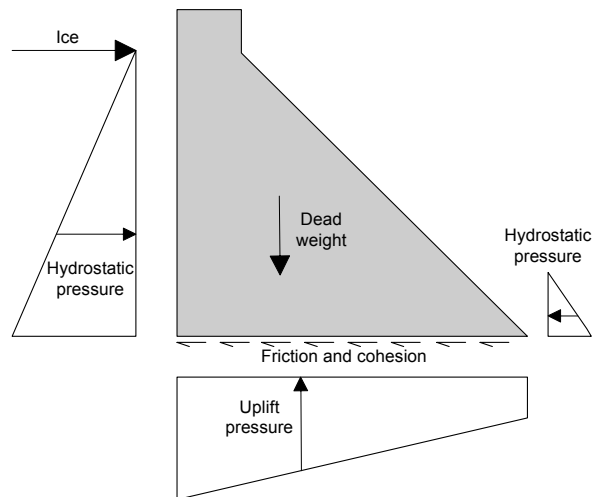


Figure 6-1 - Forces on gravity dam.

This chapter starts with the definition of resistance parameters and continues with loads.

The main *resistance* parameters are the properties of the concrete and rock. For gravity dams the most important factors are the

- Self-weight
- Shear strength
- Compressive and tensile strength

of concrete and rock. The geometry of the section is also important. For buttress dams, where the front plate function as a beam (plate) with one end fixed in the column, substantial forces has to be withstood in the head and the above factors are even more important. This is however, dealt with in e.g. Eurocodes (EN1990, 2004).

The *loads* that a dam must withstand are

- Headwater *

-
- Uplift *
 - Ice *
 - Earth pressures
 - Temperature loads

And in parts of the world also

- Earthquake ground motions
- Sediment loads

This chapter deals only with the loads marked with *.

For each parameter the input into a structural reliability analysis is discussed.

6.1 Self weight

The self-weight of a concrete dam is a function of the volume and density of concrete and both can be described as random variables, but it is generally difficult to specify them separately and the below values include both volume and density variability.

According to JCSS (2001) the uncertainty of the magnitude of variation in self-weight is normally small in comparison to other kinds of loads and the variability with time is normally negligible.

In JCSS the mean value of concrete density is set to 24 kN/m^3 . This is valid for concrete without reinforcement and with stable moisture content. In case of continuous drying under elevated temperature the stable volume weight after 50 days is $1.0\text{-}1.5 \text{ kN/m}^3$ lower. The coefficient of variation is 0.04. For large structures there also exist spatial correlation and the variability of the weight density may be taken as

$$V_x \cdot \rho$$

where ρ is the correlation coefficient. If other information is not available ρ may be taken as 0.85 for a large member and for a whole structure consisting of many members ρ may be taken as 0.7.

A gravity dam can be considered to be a large structure, and with this information the concrete density of a concrete gravity dam should be taken as

$$\mu = 24 \text{ kN/m}^3 \text{ and}$$

$$\text{COV} = 0.04 \cdot 0.85 = 0.034$$

The weight density of concrete is assumed to have a normal distribution and the resulting distribution is shown in Figure 6-2.

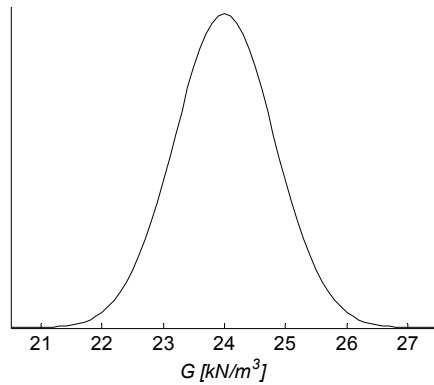


Figure 6-2 - distribution of self-weight, $\mu = 24$, $COV = 0.034$.

CIB (1989), which is the back-ground information to JCSS (2002), gives a mean value of 23.5 kN/m^3 and COV of 0.04 for concrete of compressive strength 20 MPa, and 24.5 kN/m^3 and $COV = 0.03$ for concrete of compressive strength 40 MPa.

In the assessment of a concrete dam the above information (from e.g. JCSS) could be used as *a priori* information and samples from the structure could be used for updating to give the *a posteriori* information. The structural reliability analysis would then be based on the *posteriori* distribution.

It is important to note that for a concrete dam the volume can be difficult to determine. Design drawings does not provide good information and as-built drawings may also be inadequate, but must in most cases be relied upon. If large uncertainty exist or if the structure is not likely to have dimensions according to the as-built drawings measuring of the structure and drilling to find the rock level may be used.

Dams are built in a quite hostile climate, where the leaching of water or mechanical damage may reduce concrete volume or density. If uncertainties exist as to the status of the material properties they should be tested.

The density of rock is dependant on rock type and has to be estimated case specifically.

According to JCSS (2001) the mean values of dimensions usually equal the nominal values. The variability of volume may be estimated from standard deviation for the dimensions. Nothing in specific is mentioned of concrete dams.

6.2 Strength of concrete and rock

6.2.1 Cohesion of concrete-rock interface

The cohesion in the interface between rock and concrete is of major importance for the sliding stability of concrete dams. The uncertainties concerning cohesion are however large, making use of cohesion difficult.

The following difficulties are typical:

- Tests are few (if any)
- The bond of a drilled core may be intact or broken, but it may not be immediately clear if a broken contact was broken from the start or during drilling

6.2.1.1. Magnitude and extent

The cohesion may be estimated by tensile tests, giving the cohesion as $c = 2f_t$, where f_t is the tensile strength (Griffith's failure criteria, Lo et al. (1991)). Combined uniaxial and triaxial tests can be used to determine the complete failure envelope, hence giving the cohesion.

In China Electricity Council (2000) the cohesion is assumed to be lognormally distributed. Re-calculation from characteristic values indicate the following mean values and standard deviations for different types of rock quality:

Table 6-1 – Cohesion of interface estimated based on China Electricity Council (2000).

Quality of rock	E [MPa]	$V^{-1/2}$ [MPa]	V_s
dense and sound	1.3-1.5	0.47-0.54	0.36
sound, weakly weathered, crack spacing 0.5-1 m	1.1-1.3	0.40-0.47	0.36
medium sound, weakly weathered, crack space 0.3-0.5 m	0.7-1.1	0.28-0.40	0.36-0.4

Other results, presented in Ruggeri et al. (2004) indicate the cohesion values in Table 6-2. For some results the size of specimens is known, for others it is not. Results by Lo and ISMES (see Ruggeri et al.) indicate that the cohesion is not sensitive to rock type. Several of the investigations (Lo, EPRI) conclude that failure along planes of weakness (bedding planes and joints) is common in tests and that the concrete-rock contact is not necessarily the most critical.

Table 6-2 – Cohesion of interface, from Ruggeri et al. (2004).

Institute/author	c [Mpa]	Comment	Size
Rocha	0.1 – 0.7	In situ tests	70*70 cm
Link	0.1-3.0	In situ	Unknown
EPRI	1.3-1.9	best fit line (shale excluded)	5-15 cm
	0.3-1.1	lower bound line (shale excluded)	

Lo & Grass (1994) performed direct tensile test of cores. Those that failed along the contact zone showed tensile strength of 0.92 MPa (based on 20 dams) and 1.08 (based on 13 dams), indicating cohesion of 1.84-2.16 MPa. The size of the specimens is not presented, but from pictures they are estimated to have a diameter of 5.5 cm. Lo & Grass also present results from tensile tests of the contact zone for two dams investigated, these are summarized in Table 6-3. From the first dam, 12 boreholes were drilled and seven cores were intact and five were broken. The locations of the intact samples indicate that the distribution is random, inferring that the bonded area of the

dam-foundation interface is evenly distributed. For the second dam, 21 boreholes were drilled. Nine were intact and twelve were broken, four of the broken ones were assessed to be weakly bonded. Seven of the intact cores were tested. Several of the unbonded/weakly bonded cores were found to originate from the same section, indicating weak to no bonding in this part.

Table 6-3 – Cohesion of interface, from Lo & Grass (1994).

Location	Tensile strength [Mpa]	Estimated c [Mpa]	Comment
1	0.92	1.84	dam 1, intact (tensile)
2	2.34	4.68	dam 1, intact (tensile)
3	0.95	1.9	dam1, intact (triaxial)
4	1	2	dam 1, partly intact (tensile)
5	0.97	1.94	dam1, intact (triaxial)
6	1.4	2.8	dam1, intact (triaxial)
7	0.46	0.92	dam 1, intact (tensile)
8	0.46	0.92	dam 2, partly intact (tensile)
9	0.9	1.8	dam 2, intact (tensile)
10	1.61	3.22	dam 2, intact (tensile)
11	0.53	1.06	dam 2, intact (triaxial)
12	0.64	1.28	dam 2, intact (tensile)
13	1.55	3.1	dam 2, partly intact (tensile)
14	0.23	0.46	dam 2, intact (tensile)

Mean value and standard deviation for dam 1 is 2.36 and 1.62 MPa, for dam 2 it is 1.8 and 1.14 MPa and for both dams 2.02 and 1.30 MPa, indicating $V_x = 0.64-0.69$.

In Paper I cohesion was estimated from tensile tests from a dam facility. Eight cores were taken, four were intact, and four were broken. One of the broken cores was considered broken by drilling and the others were considered broken beforehand as deposits were seen on the surface. The results of the tensile tests indicate cohesion is shown in Table 6-4.

Table 6-4 - Results of cohesion from Paper I.

No.	c [MPa]
1	0.48
2	1.40
3	1.78
4	1.68

The mean value and standard deviation from these tests are 1.33 and 0.59 MPa, respectively, giving $V_x = 0.44$. The ratio of intact cores to broken cores indicates that cohesion may be considered present at approximately 60 % of the area.

Results in the EPRI report (EPRI, 1992) of five large scale in situ tests show that three failed along weak planes rather than in the contact and that the other two failing along the contact were at the upper bound of small scale laboratory test results of the same rock type. EPRI, however, concludes that “Tests on the small samples tend to overestimate the actual field strengths. This phenomenon is known as the “scale effect”. Whether the scale effect occurs in the case of shear strength tests is controversial.”

The scale effect is also discussed by e.g. Bandis et al. (1981). They performed experiments to study the scale effect on the shear behaviour of rock joints. Their results show that increasing block size or length of joints leads to a gradual increase in the peak shear displacement and transition from brittle to plastic failure mode, as shown in Figure 6-3.

Fishman (2009) gives results of large-scale (exact size unknown) block shear tests from 32 geological sites in the foundations of 24 dams. Friction coefficient $\tan\phi$, cohesion c and E -modulus are presented for different types of rocks. The cohesion values presented range from 0.06 MPa (for a tectonic zone) to 2.6 MPa (for a dolomitic limestone) with a mean value of 1.13 MPa and a standard deviation of 0.74 MPa. If these results would be different for smaller size is not known.

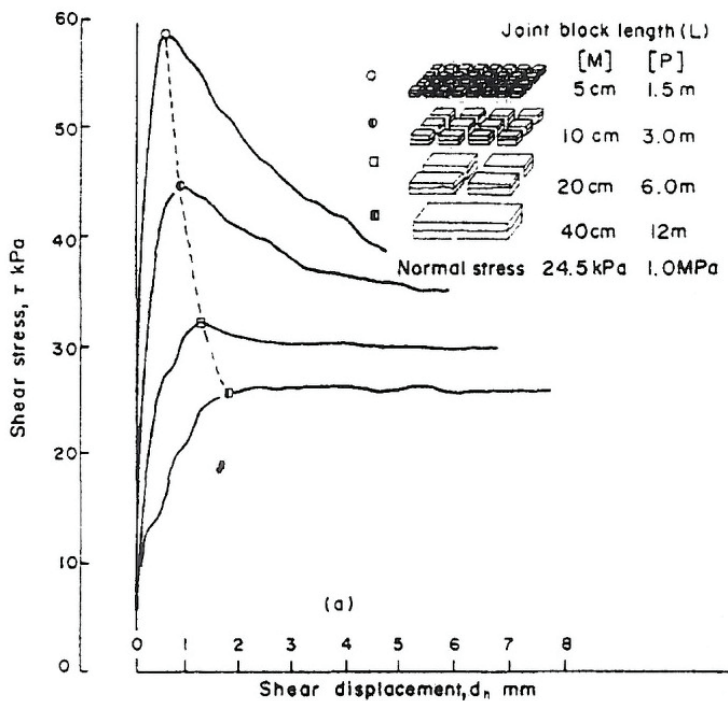


Figure 6-3 - Cumulative mean shear stress - shear displacement (from Bandis et al (1981)). M is the model size and P the size the model represents in the real world.

6.2.1.2. Representation for the interface

It must be recognized that the above cohesive strength are that of individual samples, representative for an area the size of drilled cores, taken at random locations of the structure. The shear strength is not constant for the whole surface, but rather a function of a number of small elements, each with certain cohesion. Most stability analyses presented in literature, if cohesion is included, assume a value for the whole interface (and where relevant combine this with the associated standard deviation), but if the values resulting from tests of cores is representative for the whole surface is not discussed.

Since sliding failure with cohesion present occurs at very small displacement, the ability to redistribute the load is very limited. This means that the cohesion may not be treated as a mean-value driven process, but rather as a brittle parallel system.

In this thesis a simulation procedure is proposed on how to deal with cohesion. Some problems remain to be solved, but the main ideas are thought to be useful and give better estimates than just assuming the cohesion to be a mean value for a large area. These results were applied to the reliability analysis presented in Paper I. Research on this method will continue.

Cohesion has been simulated by a procedure described below, based on the following assumptions:

1. The cohesion in the contact between rock and concrete may be described as a random field, divided into n elements. Each element has a cohesion of c_i , $i = 1 \dots n$.
2. $c_i \sim \text{LN}(E, V^{1/2})$.
3. There is a correlation with distance, a range of r m.
4. $n_{c0} = d \cdot n$ of the elements have $c_i = 0$. d is the part of the contact that is unbonded.
5. The cohesion of the interface is considered a brittle parallel system.

The lognormal distribution is used as this was used in China Electricity Council (2000) and because it does not result in values less than zero. Assumption 3 is considered reasonable since the cohesion is expected to be quite high when the rock quality is good, the rock surface was cleaned before concrete casting and the concrete was of good quality and without separation, whereas bad quality and cleaning may give low or no cohesion. The parts with good and bad quality are assumed more likely to appear in “clusters”, hence to have some range. The result of $r \approx 0$ is a random field where high values of cohesion are mixed with low values, while for $r > 0$ there will be larger areas of high cohesion and larger areas of small cohesion, the latter seems to be more likely.

As described in chapter 3 for a brittle parallel system the resistance is given by

$$R_n = R_n(c_1 \dots c_n) = \max\{n \cdot \hat{c}_1, (n-1) \cdot \hat{c}_2 \dots \hat{c}_n\}$$

where

$$\hat{c}_1 \leq \hat{c}_2 \leq \dots \hat{c}_n$$

are the order statistics of $c_1 \dots c_n$.

An example for a small surface with $n = 9$ elements is given here. The properties of the elements are randomly picked from $c_i \sim \text{LN}(1.3; 0.6)$, based on the results from Paper I. $r = 0$ is assumed. The area of one element is a_1 . The total area is thus $9a_1$.

1.04	1.15	0.72
1.60	2.76	1.49
0.85	1.32	0.83

$$\hat{c}_1 = 0.72; \hat{c}_2 = 0.83; \hat{c}_3 = 0.85; \hat{c}_4 = 1.04; \hat{c}_5 = 1.16$$

$$\hat{c}_6 = 1.32; \hat{c}_7 = 1.49; \hat{c}_8 = 1.60; \hat{c}_9 = 2.76$$

$$\rightarrow R_n = \max \left\{ \begin{array}{l} 0.72 \cdot a_1 \cdot 9 = 6.48; 0.83 \cdot a_1 \cdot 8 = 6.64; 0.85 \cdot a_1 \cdot 7 = 5.95; \\ 1.04 \cdot a_1 \cdot 6 = 6.24; 1.16 \cdot a_1 \cdot 5 = 5.8; 1.32 \cdot a_1 \cdot 4 = 5.28; \\ 1.49 \cdot a_1 \cdot 3 = 4.47; 1.60 \cdot a_1 \cdot 2 = 3.2; 2.76 \cdot a_1 \cdot 1 = 2.76 \end{array} \right\} = 6.64 \cdot a_1$$

$$c_{R_n} = \frac{6.64 \cdot a_1}{9 \cdot a_1} = 0.74$$

Figure 6-4 - Example of simulation for a brittle parallel system.

For a surface with the same properties as in the above example (and the properties used below) the maximum resistance is given by values corresponding to approximately the 25% quartile of the lognormal distribution. This means that approximately 25 % of the surface will have cohesion less than the cohesion giving the resistance. If the surface were a parallel system, failure would occur when the strongest element failed, and if it were a series system, failure would occur when the weakest element failed. The results here indicate failure when 25% of the elements fail (or 25% of the surface fail). For another type of distribution of c_i the result would be different.

6.2.1.3. Simulation procedure and results

1000 realizations of a random field with $c_i \sim \text{LN}(1.3; 0.6)$ and $r = [0, 2, 4, 12]$ m is made with the software R! (Hornik, 2006) using the package RandomFields (Schlater, 2001) and an exponential variogram (for further information of variogram, see Paper III). Different refinements are tested, $n = [800, 3200, 12800]$ for an area of $A = 22 \cdot 27.65 \text{ m}^2$. n_{c0} elements are randomly assigned $c_i = 0$, $n_{c0} = d \cdot n$, where $d = [0, 0.25, 0.5, 0.75]$. R_n is calculated for each realization, and the distribution of R_n for all the 1000 realizations are assumed representative for the cohesion of the whole surface, $c_{surf} = R_n/A$. Expected value and variance of c_{surf} are $E(c_{surf})$ and $V(c_{surf})$, respectively.

According to Hohenbichler & Rackwitz (1981) R_n will be asymptotically normal. In this analysis the best fit was however the lognormal distribution, probably because n is not large enough. Note also that for $r = 0$, $\lim_{n \rightarrow \infty} V(c_{surf}) = 0$ while for a large n

$$\lim_{r \rightarrow \infty} E(c_{surf}) = E(c_i) \text{ and } \lim_{r \rightarrow \infty} \sigma(c_{surf}) = \sigma(c_i)$$

Table 6-5 - Results of simulation of cohesion as a brittle parallel system. Expected value, standard deviation and coefficient of variation for c_{surf}

d	n	$r = 0$			$r = 2$			$r = 4$			$r = 12$		
		μ	σ	V_x	μ	σ	V_x	μ	σ	V_x	μ	σ	V_x
0	800	0,66	0,01	0,02	0,67	0,05	0,08	0,68	0,10	0,15	0,74	0,21	0,28
0	3200	0,66	0,01	0,01	0,67	0,06	0,08	0,68	0,10	0,15	0,75	0,22	0,29
0	12800	0,66	0,00	0,01	0,66	0,05	0,08	0,67	0,10	0,14	0,74	0,21	0,29
0,25	800	0,52	0,01	0,02	0,51	0,04	0,08	0,51	0,08	0,15	0,56	0,16	0,28
0,25	3200	0,52	0,01	0,01	0,50	0,04	0,08	0,51	0,08	0,15	0,56	0,17	0,30
0,25	12800	0,51	0,00	0,01	0,49	0,04	0,08	0,50	0,07	0,14	0,55	0,16	0,29
0,5	800	0,41	0,01	0,03	0,34	0,03	0,08	0,34	0,05	0,15	0,37	0,10	0,28
0,5	3200	0,4	0,01	0,02	0,34	0,03	0,08	0,34	0,05	0,15	0,38	0,11	0,29
0,5	12800	0,4	0,00	0,01	0,33	0,03	0,08	0,34	0,05	0,14	0,37	0,11	0,29
0,75	800	0,32	0,01	0,04	0,17	0,02	0,09	0,17	0,03	0,15	0,19	0,05	0,28
0,75	3200	0,31	0,01	0,02	0,17	0,01	0,08	0,17	0,03	0,15	0,19	0,06	0,30
0,75	12800	0,31	0,00	0,01	0,16	0,01	0,08	0,16	0,02	0,14	0,18	0,05	0,29

The results show that

- The refinement is not important for the refinements tested in relation to the surface dimensions. The refinements tested $n = (800, 3200 \text{ and } 12800 \text{ elements for a surface of } 22 \times 27.65 \text{ m}^2)$ showed no influence on the mean value or standard deviation.
- Increasing r increases the mean value and the standard deviation. The results of range $r = [0, 2, 4, 12] \text{ m}$ show that the large range gives larger mean value and larger variance, as expected.
- For the case when there is cohesion on only a part of the surface, the expected value and standard deviation may be estimated by

$$E(c_{surf} | d > 0) \approx E(c_{surf} | d = 0) \cdot d \quad \text{and} \quad V^{1/2}(c_{surf} | d > 0) \approx V^{1/2}(c_{surf} | d = 0) \cdot d,$$
 where d is the part of the area that is not intact. According to the simulation results this overestimates the standard deviation for cases when the intact part is small, but since this is an assumption on the conservative side it is considered acceptable.

To investigate the effect of random locations of elements with $c_i = 0$ compared to clustering, i.e. that the elements with $c_i = 0$ appear in larger numbers, three strategies were used in another simulation with an area of $5 \times 11 \text{ m}$ and [12800; 3200; 800] elements:

1. Random picking of n_{c0} elements that are assigned $c_i = 0$.

-
2. Random picking of $n_{c0}/4$ elements, and each of these elements and 3 of the surrounding elements are assigned $c_i = 0$. This gives the same n_{c0} , but the elements appear in clusters.
 3. Same as 2, but with clusters of 16 elements.

The results showed that the choice of elements with $c_i = 0$ (one by one or in clusters of 4/16) does not affect the end result, hence the choice of elements with $c_i = 0$ can be done randomly.

The above principle presupposes that the shear stress is evenly distributed. If this is not the case the parts subject to the highest stress will be more probable to break first. In that case the real stress distribution as well as the real resistance distribution will be very important. Uneven stress distribution may result in a brittle parallel system of less elements than assumed here, which will give smaller resistance.

6.2.2 Internal friction angle of the concrete-rock interface

The internal friction angle is dependant on material (strength). As the failure envelope is non-linear, the level of normal stress is important when ϕ_i is estimated. The failure envelope may be found by conducting uniaxial and triaxial tests.

A summary performed by EPRI (1992) showed that the internal friction angle of a bonded concrete-rock interface is usually in the range 54-68°.

Fishman (2009) gives results of internal friction angle from 32 tests from 24 dam sites, with a mean value of $\tan\phi_i = 1.29$ (52.2°), standard deviation 0.37, minimum value 0.52 (27.5°) and maximum value of 1.96 (63°).

The distribution for ϕ_i should be based on tests from cores taken at a dam site. In the papers presented in this thesis a normal distribution has been assumed where

$$\tan\phi_i \sim N(1.37; 0.15).$$

As noted in (4.9) in section 4.3.1.4.1, the amount of normal force on the part with cohesion, R , is important. To estimate R is not an easy task, since the distribution of cohesion in reality is unknown. For a gravity type dam where the correlation distance of cohesion and the amount of broken contact is known, R may be estimated, assuming linear stress distribution, in the same analysis as the cohesion is modelled (the methodology described above).

6.2.3 Basic friction angle and dilatation

In order to determine the basic friction angle shear tests of drill cores are usually performed. The best estimates are obtained from cracked surfaces when the measured friction angle is corrected for small-scale dilatation (the dilatation has to be measured during a test where the rate of shear displacement has to be low in relation to the dilatation).

According to Lo et al. (1991) the basic friction angle is 30-39° and no difference was found between different types of rock. A summary in EPRI (1992) shows $\phi_b = 34-39^\circ$.

To estimate the effective dilatation angle, i , knowledge of the rock surface along the foundation (or joint) is necessary. For dilatation to occur, the size of the asperities must be large enough in order to prevent that shearing along the base of the asperity or through the concrete do not occur. Gustafsson et al. (2008) estimates that for typical Swedish dams, with heights between 10-30 m, the length of an asperity has to be at least 5% of the dam height. A schematic picture of this is given in Figure 6-5.

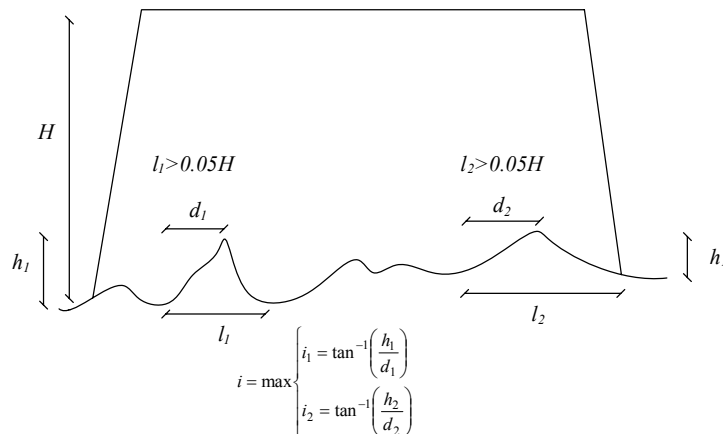


Figure 6-5 - Schematic picture of dilatation angle.

6.2.4 Friction angle and cohesion of rock mass

May be estimated as indicated in section 4.3.1.2.

To estimate the parameters of (4.6), large scale triaxial tests can be used, but this is cumbersome and expensive. Instead different types of rock mass classification systems, e.g. Q-index, Rock Mass Rating (RMR), Geological Strength Index (GSI) or Rock Mass Strength (RMS), may be used, see e.g. Gustafsson et al. (2008). These methods can be used to describe the quality of the rock mass and to estimate ϕ_m and c_m . There are also empirical failure criteria that may be used for this, e.g. the Hoek-Brown failure criterion. A procedure to determine the above parameters based on Hoek-Brown is described in Gustafsson et al. (2008).

6.2.5 Basic friction angle and dilatation angle of rock joints

The basic friction angle must be estimated based on tests on drill cores, following the procedure in section 6.2.3. In Paper I the basic friction angle was assumed to be 33° . Results from two test rounds presented in Johansson (2009) gave mean $\phi_b = 35^\circ$ and 37.4° , respectively. Tests performed by Johansson (2009) and Papaliangas (see ref in Paper I) indicate that the basic friction angle could have a coefficient of variation of about 0.05.

The dilatation angle can be estimated based on back calculation from JRC-values (Gustafsson et al., 2009). The dilatation angle is scale dependant, which has to be

considered, see e.g. Bandis et al. (1981). Gustafsson et al. present several studies where the dilatation angles for large in-situ joints ranged between 0-15°.

6.2.6 Shear strength of concrete lift joints

Table 6-6 summarize the shear strength for lift joints from tests (from Ruggeri et al, 2004 and EPRI, 1992), i.e. quite high friction angles and cohesion.

Table 6-6- Shear strength of lift joints.

	Procedure	Strength	ϕ [°]	c [MPa]	Comments
EPRI	Data from 10 dams (built 1906-1973), 223 specimens were tested (69 bounded, 154 unbounded)	<i>Peak strength</i>			For un-bonded samples an apparent cohesion is the result of small, high angle asperities on the surfaces.
		Best fit line:	57	2.1	
		Lower bound:	57	1	
		<i>Residual strength</i>			
		Best fit line:	49	0.5	
		Best fit line (bilinear) $\sigma < 0.3$ MPa	68	0	
$\sigma > 0.3$ MPa	49	0.3			
		Lower bound: $\phi = 48^\circ$, c = 0 MPa	48	0	
McLean and Pierece	Direct shear tests carried out on samples from USBR dams	<i>Peak strength</i>			Bonded lift joints had a peak strength nearly identical to concrete ($\phi = 58^\circ$, c = 2.5 MPa)
		Best fit line:	55	2.4	
		<i>Residual strength</i>			
		Best fit line:	47	0.6	

6.2.7 Compressive and tensile strength of concrete

For concrete the compressive resistance may be estimated according to Carlsson et al. (2006). Strength increase due to ageing may also be included. The characteristic value of compressive strength, f_{ck} , is usually known and the relation between mean value, f_{cm} , and characteristic value is

$$f_{cm} = f_{ck} \cdot \exp(1.64 \cdot V_x) \quad (6.1)$$

where V_x is the coefficient of variation. If V_x is not known $\sigma_{fc} = 5$ MPa may be representative. The in-situ 28 day strength may be calculated as

$$f_{cm, is} = \kappa \cdot f_{cm} \quad (6.2)$$

where $\mu(\kappa) = 0.85$ and $V(\kappa) = 0.06$.

The increase in compressive strength due to ageing (up to a certain age) is dependent on cement type, temperature and curing conditions. CEB-FIP Model Code (1990) recommends the following formula for compressive strength at age t (days):

$$f_{cm}(t) = \beta_{cc}(t) \cdot f_{cm} \quad (6.3)$$

where

$$\beta_{cc}(t) = \exp \left[s \left(1 - \left(\frac{28}{t} \right)^{1/2} \right) \right] \quad (6.4)$$

s is a coefficient depending on cement type (0.2 for rapid hardening high strength, 0.25 for normal and rapid hardening and 0.38 for slow hardening). A reasonable assumption is $COV\beta_{cc} = 0.3$.

The tensile strength in bending is, according to Carlsson et al. given as

$$f_{ctm} = 0.3 \cdot f_{ck}^{2/3} \quad (6.5)$$

6.3 Headwater

Any dam with a reservoir will be exposed to hydrostatic water pressure, determined by the head water level. The uplift pressure is also a function of the head water level. This section describes the characteristics of head water and suggest how to treat it in structural reliability analysis.

6.3.1 Flows in unregulated and regulated rivers

In unregulated rivers in the north part of Sweden the highest flow occurs in spring because of melting snow, while in the south part it occurs in autumn or winter because of large precipitation. In regulated rivers water is stored in reservoirs, either natural lakes or artificial ones built up by dams. The Swedish electrical energy production consists of about 45 percent hydropower, 45 percent nuclear power and about 10 percent from combined power and heating plants, wind and other. The consumption is highest in winter, autumn and spring and during these periods nuclear power is used to high extent, whereas the more flexible and adjustable hydropower is used as complement and in peak situations during the day. The reason is that hydropower, as water is stored in reservoirs, can be saved for periods of high demand and high energy prices. As high water levels (larger head) give higher utilisation water is kept as close to retention level as possible.

The result of storing water in the reservoirs is more uniform water flow in the rivers than in unregulated river systems and before construction of dams in the river, and in most cases lower peak flow. This is, however, not always the case since regulation can cause larger flows than the natural. The risk of large flows due to this increase in long periods of wet weather when reservoirs are filled and water must be discharged through several dams (Bergström, 1993).

For unregulated rivers the flow has an “inherent” randomness, resulting in aleatory uncertainty. The flow can be seen as a random process in time. To describe the flow, models are used, that are themselves subject of epistemic uncertainty. For more information of epistemic and aleatory uncertainties, see chapter 2. If, in theory, an infinite amount of data was available, the epistemic uncertainty could be eliminated and it would then be possible to describe the flow, but the aleatory uncertainty would still be

present (for definition and use of aleatory and epistemic, see e.g. Hartford & Baecher, 2004).

The situation in a regulated river is quite different. The runoff water from surroundings can still be described as a random process in time with an aleatory uncertainty, but the river flow is now also subject to other processes; water is saved for use in situations when it is needed, resulting in more flow in cold weather (when the natural situation would result in precipitation as snow), less water during spring due to lower energy demand, etc. The result is that the flow in a regulated river can not be fully described as a random process in time and the uncertainty is thus not aleatory. Or, more correctly, part of the uncertainty is aleatory but the greater part is assigned to the uncertainties of policy, of regulation etc that are largely influenced by humans and thus those uncertainties can be looked upon as a result of human factors.

The above description is true for “normal” situations. In case of extreme precipitation water flow can no longer be stored to great extent, as regulation of rivers reduce the ability of natural damping at high reservoir levels, and the result can be large floods that are not, or only partially, influenced by human activity. These situations are thus the result of more aleatory uncertainty, but due to the effect of regulation it is not the “same” aleatory uncertainty as for the natural flow.

6.3.2 Calculation of design flow

Where dam breach would cause loss in human lives or large economic or environmental damage the acceptable probability is very low, and return periods of 10 000 years are used for design floods. Calculation of the flow corresponding to this differ, however, between countries and regions, as there are, at present, no internationally accepted method for calculation of design flow in regulated rivers for large dams.

For most dam sites the statistical data of maximum yearly flood only extends for some 50 or 100 years, which is not sufficient to make a frequency analysis, as the tail, which is most important for extreme floods, is dependant on choice of distribution. In the USA federal governments therefore only accept extrapolation to return periods twice the observation period for data (Flödeskommittén, 2007).

There are different approaches to derive the design flood; methods based mainly on flow data or methods based mainly on rainfall data, such as the PMP. PMP (Probable Maximum Precipitation) is the “theoretically greatest depth of precipitation for a given duration that is physically possible over a given size storm area at a particular geographic location at a certain time of year” (Flödeskommittén, 2007).

In many countries design floods for large dams are based on PMP used in a hydrological calculation model to estimate the PMF. PMF (Probable Maximum Flood) is the flow that can be expected from the worst combination of critical meteorological and hydrological conditions that can reasonably be expected in the region (ICOLD, 1992). The PMP-concept is not useful in Sweden as it does not account for snowmelt, which significantly contributes to the largest floods.

In 1985 the Swedish Committee for Design Flood Determination (Flödeskommittén, 2007), was appointed to give new guidelines on the calculation of design floods for Swedish dams. The reason was that high floods during the summer and autumn of 1983 indicated that the discharge capacity of dams could be insufficient in case of extreme inflow and full reservoirs.

The design flood calculation for Flood Design Category I facilities (high consequence dams) proposed by the Committee is based on the HBV-model (a model taken out by SMHI (Swedish Meteorological and Hydrological Institute) in cooperation with the powerindustry) where a precipitation during 14 days (based on data of precipitation sequences from 1881-1988) over a 1000 km² area (updated based on altitude and size of the specific drainage basin) is combined with extreme snowmelt of a snowpack with return period of 30 years, a reservoir level corresponding to what might be expected at the time of year of interest and high amount of soil moisture (Bergström, 1993, Flödeskommittén, 2007). The committee estimated that a design flood calculated by this method has a return period that exceeds 10 000 years, but probabilities can not be assessed more closely.

For Flood Design Category II facilities, data from observed floods can be extrapolated to a longer return period (but not longer than 2-3 times the data) to give the design flood, which should be at least equal to the 100-year flood.

For a number of reasons; ecological, economical etc, head water for Swedish dams are kept between the minimum retention level and the retention water level which is the maximum level allowed. The water-rights court defines these levels and allowance for necessary violation has to be applied for in advance (or in extreme situations afterwards).

Apart from the difficulty to assess probabilities of flood, there are also difficulties related to determination of discharge capacity at different head water levels. Physical model tests are frequently used for this.

6.3.3 Treatment of headwater level

In a structural reliability analysis statistical distributions for loads and resistances are needed as input. From the above account it is obvious that this is not possible to attain for the flood, and hence for the head water level, but a method to deal with this in a structural reliability analysis is proposed. This method provides the complete CDF (cumulative distribution function) of headwater, even though the analysis have to be divided in two parts. An alternative would be to make a fragility analysis, as e.g. Ellingwood & Tekie (2001), Tekie & Ellingwood (2003), Lupoi et al. (2009) and some others did. Ellingwood (2009) points out that in cases where the annual frequency of the threat is unknown or amenable to traditional statistical modelling, one must envision a set of hazardous scenarios without regard to their probability or frequency of occurrence.

According to Tekie & Ellingwood (2003) each limit state probability can be expressed as

$$P[LS] = \sum_y P[LS|Y=y]P[Y=y] \quad (6.6)$$

where Y is the random variable describing the intensity of demand (e.g. head water level), $P[Y=y]$ defines the probability of this demand and $P[LS|Y=y]$ is the conditional probability of the limit state, given that $Y = y$. This conditional probability is denoted the fragility. One example of a fragility curve is shown below, where the probability of sliding is conditional on the head water level.

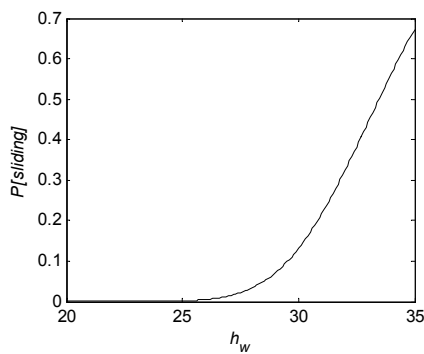


Figure 6-6 – Example of fragility curve for sliding of a concrete gravity dam. $h_{rwl} = 20m$ in this case.

A fragility curve gives the safety index or probability of failure as a function of one variable, but does not take into consideration the frequency of occurrence of the different levels of the variable. For this reason it may give valuable information of the sensitivity, but it does not provide information of the actual reliability. Where possible a full reliability analysis is preferable to fragility curves.

For Swedish conditions the following method for full reliability analysis should be possible to use for many dams.

According to the guidelines, a Flood Design category I facility should be able to discharge a design flood with a return period of approximately 10 000 years. In some cases the discharge facilities are capable of discharging this flow at rwl (retention level), but in others water levels above retention level has to be allowed to discharge sufficient amount of water.

The formulation of headwater h_w in the structural reliability analysis is divided into two parts. In the following d_e is the level of water exceeding the retention water level h_{rwl} .

1. h_w constant at rwl, i.e. $d_e = 0$ m. The annual frequency of occurrence is $P = 1 - P(d_e > 0)$, which can be considered to be 1.

Headwater at retention water level is considered the “normal case”. Water levels below retention water level may occur, but as the statistical distribution should be based on annual maximum values, and it is likely to reach retention

water level at least once in a year this possibility is conservatively neglected. If uplift pressure monitoring results are available, these can be used as input. If so, risk of drain clogging and grout curtain leaching has to be considered properly.

2. h_w above rwl i.e. $d_e > 0$ m. The annual probability of occurrence is $P(d_e > 0)$.

For facilities in consequence class 1 and 2 (according to RIDAS) (Flood Design category I or II according to Flödeskommittén) the 100-year flood shall be possible to discharge with headwater at retention water level. In many cases the floods corresponding to the 1000-year flood, or even the 10 000-year flood, is possible to discharge at retention water level for risk class I facilities. From this information $P(d_e > 0)$ may be approximated.

d_e is described by an exponential distribution and considered the exceptional case. Uplift for this case is described in section 6.4.2.

This gives the head water level according to Figure 6-7.

$$h_w = h_{rwl} + d_e \quad (6.7)$$

where

$$d_e \sim \begin{cases} 0 & | h_w \leq h_{rwl} & \text{normal case} \\ \text{Exp}(\lambda) & | h_w > h_{rwl} & \text{exceptional case} \end{cases} \quad (6.8)$$

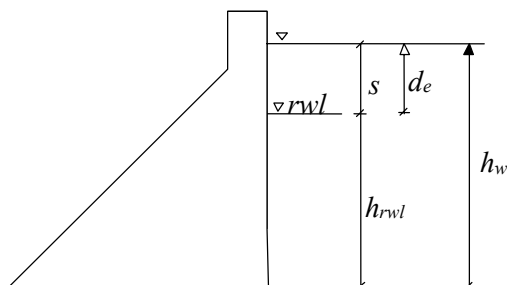


Figure 6-7 - Definition of h_w , h_{rwl} , d_e and s .

When $P(h_w > h_{rwl}) = P(d_e > 0)$ is known and $P(h_w > h_{rwl} + s) = P(d_e > s)$ for a specific water level s above h_{rwl} is known, the parameter λ in the exponential distribution can be calculated. Estimation of the probabilities and level needed for this is often done for dam facilities, or may be assessed from design flood calculation and discharge estimation.

The probability of a level s , conditional on the occurrence of $d_e > 0$ is given by

$$P(d_e > s | d_e > 0) = \frac{P(d_e > s)}{P(d_e > 0)} \quad (6.9)$$

In general, $P(X \leq x) = 1 - e^{-\lambda \cdot x}$ for an exponential distribution. Hence, from eqn. (6.8) we have $P(d_e \leq x | h_w > h_{rwl}) = 1 - e^{-\lambda \cdot x}$ for the exceptional case. Eqn (6.9) may now also be written as

$$P(d_e > s | d_e > 0) = 1 - P(d_e \leq s | d_e > 0) = 1 - (1 - e^{-\lambda \cdot s}) = e^{-\lambda \cdot s} \quad (6.10)$$

λ can be solved according to

$$\lambda = \frac{-\ln(P(d_e > s | d_e > 0))}{s} = -\ln\left(\frac{P(d_e > s)}{P(d_e > 0)}\right) / s \quad (6.11)$$

For the exceptional case ($d_e > 0$) the safety index β from analysis is conditioned on $P(h_w > h_{rwl})$ and β has to be adjusted to one year reference period by

$$\beta^* = \Phi^{-1}\left(\left[\Phi(\beta)\right]^{1/n}\right) \quad (6.12)$$

where β^* is the adjusted safety index and n is the return period in years of occurrences of the event water level above retention level (or $1/P(h_w > h_{rwl})$), see (EN1990, 2004).

The safety of the structure now have to be analysed as a a series system of

$h_w = h_{rwl}$ and $h_w = h_{rwl} + d_e$.

Apart from extreme floods resulting in large headwater levels there are other events that could give rise to the same problems. These are also briefly discussed in section 6.3.4, but not further analysed. The different cases are illustrated in Figure 6-8.

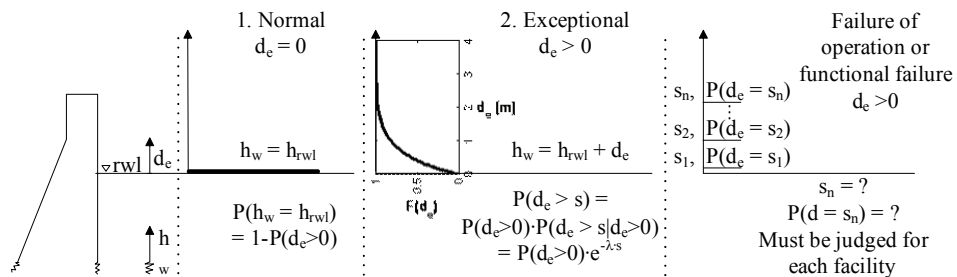


Figure 6-8 - Statistic description of headwater for normal operation, extreme floods and operational or functional failures.

6.3.4 Operational or functional failures

Other types of events can give significant contribution to the overall risk and sometimes be of larger importance than the extremely low-probability events such as the design flood. The reason is that they may be expected to occur more often. Examples are wrongful operation or mal-function of gates at medium floods or loss of control. The probability of these events and perhaps even more so, their consequences in terms of

water levels, are even more difficult to quantify than the extreme floods, but still has to be accounted for in a complete risk analysis.

Concerning operational loss of spillway gates, the probability of occurrence can be estimated from incident reports and by estimation from operation and maintenance staff. It must be remembered, however, that this information is for normal conditions, while the rate of failure functions might be higher in extreme weather conditions. The consequence in terms of higher headwater levels can then be judged based on number of gates, discharge capacity, etc for a specific flood.

When such information is available it is easily adopted in the structural reliability analysis, with calculations performed for the headwater level of interest and target safety index adjusted as in the case above.

The complete description of headwater in a structural reliability analysis is shown in Figure 6-8. Attention is not given to operational and functional failures in this thesis.

6.4 Uplift

Uplift pressure is produced in a dam rock foundation by water in fractures or pores in the foundation rock or soil. At the upstream side of the dam body the pressure equals the reservoir head, and at the downstream side it equals the tailwater head. Between these points, the uplift pressure varies depending on the loads acting on the dam, the temperature in the surroundings, the geology of the foundation rock, the type and extent of foundation treatment, and the operation of the foundation drainage system. (EPRI, 1992, Grenoble et al., 1995 and Guidicini & Andrade, 1988).

Uplift is difficult to quantify because it can only be measured at a limited number of points and may vary widely depending on the above factors (Grenoble et al., 1995). It is of major importance for the stability of concrete dams, especially concrete gravity dams which rely solely upon the weight of the structure for stability. Even so, it was not known and accounted for until the late 19th or beginning of the 20th century (Foster, 1989a), and even then it was the cause of several dam failures due to ignorance or disregard (Jackson, 2003).

The common design assumption is that the uplift is linearly decreasing from upstream to downstream water levels as shown in Figure 6-9 taking account for drainage and grout curtains by reducing the uplift as indicated in Figure 6-10. The real behaviour, in terms of “mean” uplift pressure is possible to estimate if the behaviour is indeed linear. However, for a rock foundation this assumption is not correct apart from cases where the discontinuities are numerous, evenly distributed and small (Grenoble et al. 1995). Another problem is that the variation (due to temperature changes, reservoir impoundment etc) is impossible to estimate.

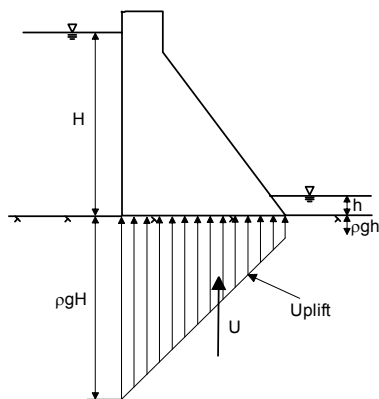


Figure 6-9 - Design assumption of uplift pressure distribution (linear case).

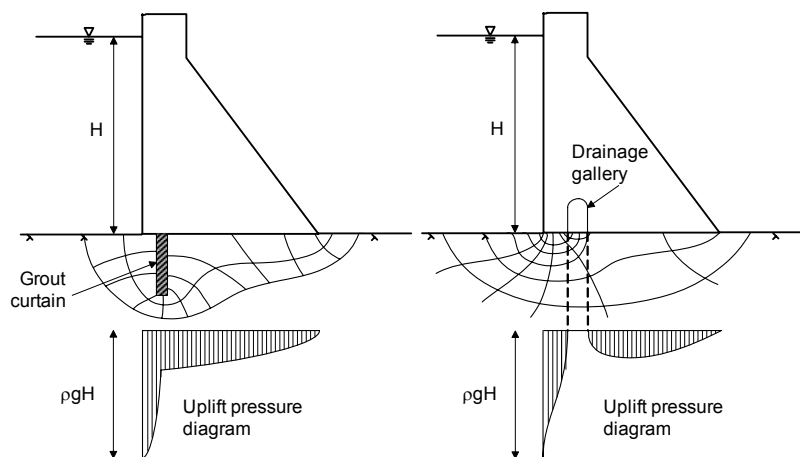


Figure 6-10 - Uplift reduction due to a) grout curtain and b) drainage gallery. After Reinius (1962).

6.4.1 Geostatistical simulation methodology and results

Due to the (often) large impact of uplift on the stability, a methodology was proposed and presented in Paper III & IV, where the uplift is obtained by solving the partial differential equation for Darcy's law for a hydraulic conductivity field. The hydraulic conductivity field was assumed possible to describe as a stochastic field with a certain mean value and variance of the hydraulic conductivity. The hydraulic conductivity field was also assumed to have a correlation distance (range), i.e. the variation is not completely random. By solving the Partial Differential Equations of a large number of different realizations of one set of indata for the hydraulic conductivity, a mean value and estimate of the variability was possible to get.

The uplift was now described as

$$U = U_d \cdot C \quad (6.13)$$

where U is the uplift force, U_d is the uplift force in the linear case (which is the result of a homogeneous foundation) and C is a random variable with mean value and standard deviation. The results indicate that $C \sim \text{Beta}(r,t,a,b)$, where r,t,a,b are parameters (for results, see Paper IV). Similarly, the moment due to uplift, calculated around the downstream toe, was described as

$$U_m = U_{dm} \cdot C_m \quad (6.14)$$

where U_m is the moment of uplift pressure, U_{dm} is the moment in the linear case and C_m is the uplift parameter. $C_m \sim \text{Beta}(r,t,a,b)$.

In Paper III & IV the properties of the hydraulic conductivity field was unknown and a number of different cases were analysed to investigate the methodology and effect of different assumptions. In Paper V indata from investigations for a dam in Brasil was used and the methodology was confirmed.

More information of uplift, the geostatistical methodology and results are found in Paper III, IV & V. As indata for the other papers, $C \sim \text{Beta}(1.96, 1.95, 0.08, 1.9)$ and for the moment due to uplift $C_m \sim \text{Beta}(2.22, 1.33, 0.11, 1.49)$ was assumed.

6.4.2 Influence of increased head

As uplift measurements are rarely available at high reservoir levels it is common practice (at least in the USA) to extrapolate the uplift from normal to high reservoir level as long as cracking (or de-compression) do not occur at the heel (Foster, 1989a). Since the relation between uplift and reservoir level is not always linear, as will be shown, this assumption can be questioned.

Grenoble et al. (1995) performed a simple finite element analysis of a concrete gravity dam section for seasonal changes in headwater level and temperature and investigated how this affects the stress distribution along the base of the dam.

For rise of reservoir, the stress distribution changes from highly compressive at the heel to less compressive and at the toe it becomes more compressive with increasing head water level. Thus, as the reservoir rises, horizontal joints below the base of the dam open near the heel and close near the toe. These deformations cause the permeability of the rock mass near the heel to increase and the permeability near the toe to decrease. Consequently, flow through the dam foundation can be simplistically viewed as flow through a tapered pipe. As the headwater level rises, the pipe becomes more tapered. Assuming that the joints do not deform will result in a non-conservative estimate of uplift pressure at higher headwater levels.

Figure 6-11 shows the result on uplift pressure; a tapered joint is subjected to different levels of headwater and as headwater rise the pipe tapers. Apparently the headwater rises cause the uplift pressure to change from a linear distribution to a curvilinear.

Grenoble et al. (1995) shows an example of a dam that exhibits curvilinear relationship between headwater level and uplift, see measurement data in Figure 6-12. In that case the joints were tight, and the deformations caused by changes in headwater level are large in relation to the initial aperture of the joints. For larger aperture joints, a more linear relation between headwater level and uplift may be expected.

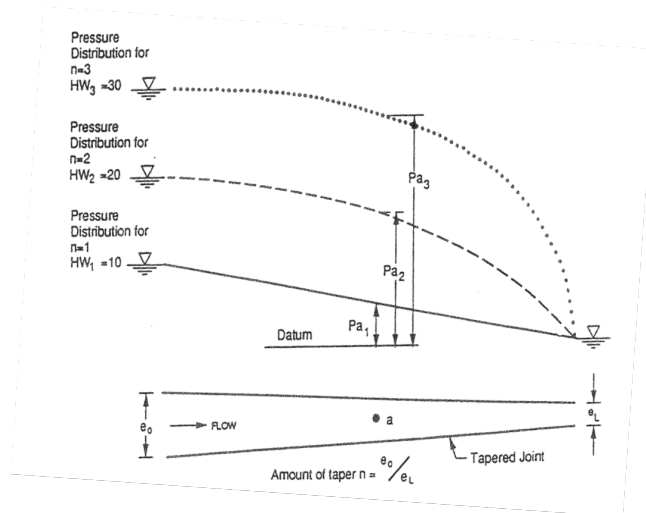


Figure 6-11 - Uplift pressure distribution caused by rise of headwater from HW1 - HW2 - HW3 (Grenoble et al., 1995).

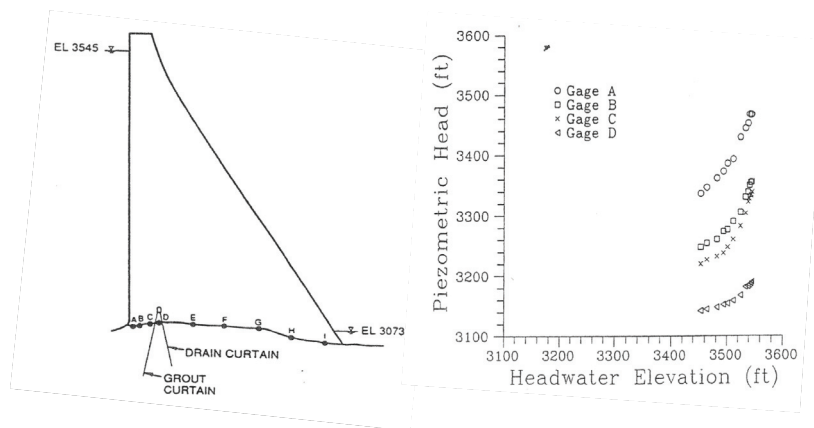


Figure 6-12 – Curvilinear relation between headwater level and uplift at Hungry Horse Dam (from Grenoble et al., 1995).

Ruggeri et al. (2001) mention that the practise of assuming that uplift pressures vary linearly with headwater is not confirmed. In three of the investigations presented in Ruggeri et al., the relations (study 1 (EDF, France), 3 (EPRI, USA) and 4 (EPRI, USA)) were non-linear.

- Study 3 showed that the increase in uplift pressure was not proportional to the rise in reservoir level, but somewhat lower. The explanation was thought to be the progressive closure of joints and other natural flow paths in the rock mass, that can be produced by increased compressive stresses resulting from increased reservoir levels. This supports the validity and logic of extrapolating uplift pressures relative to head water levels as a reasonable conservative approach.
- Study 4 (among the authors Grenoble et al. (1995) referred to above) showed that uplift pressure (data from gravity dams) exhibited non-linear variations where uplift pressures increased more than reservoir level. This behaviour was associated with the variations of the permeability of a dam foundation when the joints of the foundation rock deform as the reservoir level changes. This was also confirmed by a finite element model. It appeared that only small aperture joints deform sufficiently to give rise to non-linear uplift response. Large aperture joints will probably not deform enough under the stress changes caused by headwater variations to create noticeable non-linearity.
Grouting may stiffen joints sufficiently to prevent tapering of joints and the resulting non-linear uplift. None of the gravity dams which had extensive consolidation grouting (grouting to prevent consolidation, i.e. not with primarily uplift reduction purpose) showed non-linear uplift. Dams which would be expected to have non-linear uplift would consequently be those with tight, un-grouted joints and large variations in reservoir level.
- In study 1 both increasing and decreasing gradients of uplift pressures were observed for increased headwater levels, in rare cases for the same dam.

Ruggeri et al. (2001) concluded that it is essential to base the estimate of uplift pressure on measured pressures, because the actual uplift pressures can vary substantially from the assumption used in the design, and also underlined that measured uplift pressures can exhibit high spatial variability. Ruggeri et al. (2001) also recommend an extensive monitoring network to derive reliable uplift values for safety assessments from measured data, considering also that for gravity dams the safety assessment have to be carried out for independent monoliths. The possible variations of the measured relationship between external loads and uplift pressures must also be taken into account. In addition to possible slow and progressive variations (drifts), also the possibility of sudden variations related to the reaching of unusual or exceptional reservoir levels must be evaluated. Slow drifts can be associated to a slow variation in time of the permeabilities of the foundation. The opening of rock discontinuities can induce sudden and strong variations in uplift when the state of stress exceeds threshold values (more common for arch-gravity dams due to higher stress levels transmitted to the foundation). The extrapolation of measured uplift to higher water levels must therefore be based on a comprehensive understanding of the uplift under normal operating conditions and a

thorough understanding of how reservoir level, foundation, geology and drainage affect the uplift pressures.

6.4.3 Influence of temperature changes

Uplift pressure varies throughout the year and is strongly affected by the environmental thermal variations. Guidicini & Andrade (1988) analysed measurement from 752 piezometers from eight dams in Brazil and found that seasonal cyclic variation was found in six dams and especially in the piezometers near the concrete/rock interface and close to the upstream face, where about 10 % of the piezometers showed this type of behaviour. It was present for both hollow concrete structures, such as buttress dams, and gravity dams, but more significant for the former.

The highest uplift pressure figures occurred during the coldest winter. Noteworthy is that the temperature variation was only 10-15 degrees Celsius, and always above zero.

According to Guidicini & Andrade (1988) the uplift pressure variation due to thermal oscillation is influenced by:

- *Volumetric variations in the concrete structures.* Thermal variations cause volumetric changes in dam concrete structures that are reflected at foundation level as changes in the tensions. It is not the daily thermal oscillation, but seasonal thermal oscillation, although smaller in range, that gives the most significant results due to persistent action.
- *Volumetric variations of the discontinuous rock medium.* Any rock mass presents volumetric changes with seasonal thermal oscillations through direct incidence of the sun radiation. The temperature variation in depth will depend on thermal conductivity characteristics of the medium. The daily oscillation only reaches the approximate depth of one meter, while seasonal thermal oscillation can be detected at depths down to 20-25 meters. Presence of water strongly influences the thermal conductivity of the medium.
The part most sensitive to thermal variations are the first top meters where the most significant water percolation occur. A rock mass supporting a hydraulic structure is directly affected by thermal oscillations on the downstream side and indirectly on the upstream side. Nearby the downstream toe the discontinuities are very sensitive to volumetric variations, although the reservoir water mass reduces this effect, and small variations in hydraulic conductivity can cause considerable changes in the uplift pressure figure.
- *Influence of the water flow through the rock mass.* The water volume in a reservoir undergoes seasonal temperature oscillations. When water percolates through the rock mass the temperature drop or increase is transferred into the rock mass. Temperature drop widens the discontinuities due to volumetric contraction and temperature rise cause a decrease in width. This effect may occur not only in the concrete/rock interface but also deeper in the rock mass.

- *Variations in kinematic viscosity of the water.* A temperature drop cause an increase in the kinematic viscosity of the water, which hinders the flow.

The observed magnitude of increase in uplift pressure presented by Guidicini & Andrade (1988) was 23-45%. A time lag between low-peak of temperature and maximum uplift, where maximum uplift occurred up to two months after the lowest temperature, was observed.

According to Grenoble et al.(1995) deflection measurements typically show that the crest of the dam moves downstream in the fall and winter when the downstream face cools and contracts, and then moves upstream in the spring and summer when the downstream face warms and expands. These loads are transferred to the foundation and sub-horizontal joints near the heel will open in the winter and close near the toe. As a result the foundation can be idealized as a tapered joint where the degree of taper increases in the winter and decreases in the summer.

In Bernstone et al. (2009) and Bernstone (2006) uplift pressures under a spillway structure show increasing uplift during the cold periods, but here the maximum uplift seems to appear earlier in the season than that reported in Guidicini & Andrade, before the lowest temperatures, and time-lag is not present. The spillway section is shown in Figure 6-13 and the uplift pressure monitoring results in Figure 6-14.

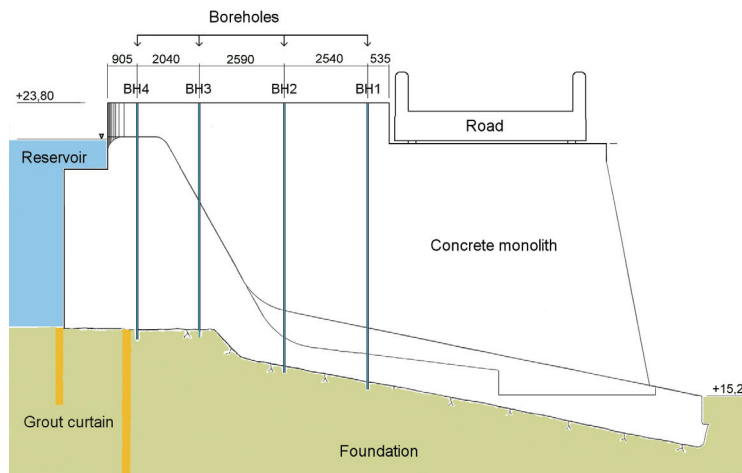


Figure 6-13 - Section of concrete monolith with installed TDR uplift pressure monitoring in BH1-4. From Bernstone et al. (2009).

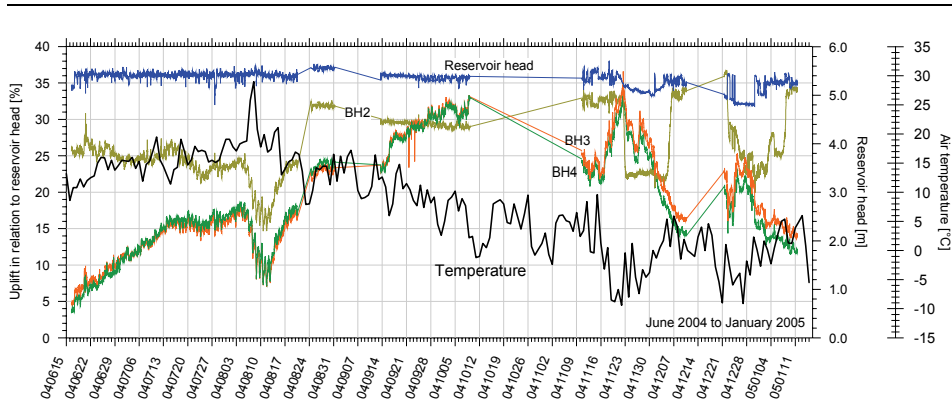


Figure 6-14 - Uplift pressure monitoring from Bernstone et al. (2009).

The joint deformations caused by changes in the reservoir and thermal loads are not necessarily in phase and can amplify or offset each other. Consequently, the maximum uplift pressure may not occur when the reservoir level is highest. The time difference between the peak in reservoir level and the peak in uplift pressure has been misinterpreted as a time lag in the response of uplift pressures to changes in headwater (Grenoble et al., 1995).

6.4.4 Description of uplift for $h_w > h_{rwl}$

As the assumption of linear increase of uplift in case of rising reservoir levels can be questioned, the use of parameters C and C_m for $h_w > h_{rwl}$ must be considered. In Paper II the uplift pressure was assumed to vary non-linearly with the increase in water level and

$$C_e = \alpha \cdot \left(\frac{d_e}{h_{rwl}} \right)^2 + \gamma \cdot C + \varepsilon \quad (6.15)$$

where C_e is the uplift force parameter in case $h_w > h_{rwl}$, and α , γ and ε are coefficients. Similarly for C_m

$$C_{me} = \alpha_m \cdot \left(\frac{d_e}{h_{rwl}} \right)^2 + \gamma_m \cdot C_m + \varepsilon_m \quad (6.16)$$

where C_{me} is the uplift moment parameter in case $h_w > h_{rwl}$, and α_m , γ_m and ε_m are coefficients

The coefficients α , γ , ε , α_m , γ_m , and ε_m are not known. In Paper II they were chosen, based on engineering judgement as $\alpha = \alpha_m = 50$, $\gamma = \gamma_m = 1$ and $\varepsilon = \varepsilon_m = 0$. There is also another point that need to be considered: the uplift force U can, due to physical restrictions, not become larger than twice that in case of linear reduction, U_d (for a flat foundation without artesian pressures beneath the dam). Similarly, U_m may not become

larger than $1.5 \cdot U_{dm}$ (different limits apply to U_m for buttress dams, see Paper III or IV). This is illustrated by Figure 6-15.

This means that for sliding when $d_e > 0$

$$G_{1,d_e>0}(\mathbf{x}) = c \cdot A_c + (G - U_d \cdot C_e) \cdot R \cdot \tan \phi_i - T \quad (6.17)$$

where

$$C_e = \min \left\{ \alpha \cdot \left(\frac{d_e}{h_{rwl}} \right)^2 + \gamma \cdot C + \varepsilon, 2 \right\}$$

As for a parallel system

$$P_f = P(\cap E_i) = P(\cap \{G_i(\mathbf{x}) \leq 0\}) = P(\{\max G_i(\mathbf{x}) \leq 0\}) \quad (6.18)$$

this treatment of uplift results in a parallel system. Hence

$$G_{1,d_e>0} = \max(G_{11,d_e>0}, G_{12,d_e>0}) \quad (6.19)$$

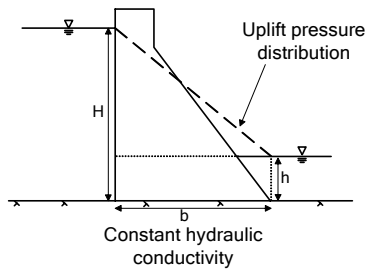
where

$$G_{11,d_e>0}(\mathbf{x}) = c \cdot A_c + \left(G - U_d \cdot \left(\alpha \cdot \left(\frac{d_e}{h_{rwl}} \right)^2 + \gamma \cdot C \right) \right) \cdot R \cdot \tan \phi_i - T \quad (6.20)$$

and

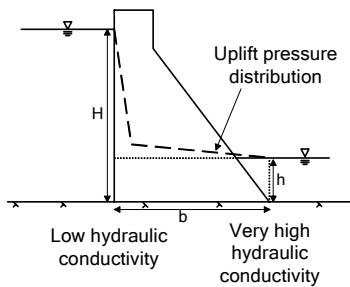
$$G_{12,d_e>0}(\mathbf{x}) = c \cdot A_c + (G - U_d \cdot 2) \cdot R \cdot \tan \phi_i - T \quad (6.21)$$

For the other failure modes (sliding with $c = 0$, adjusted overturning and sliding in rock) the same reasoning holds.



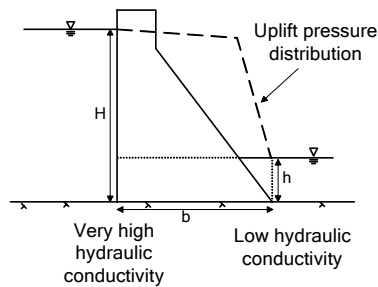
$$U = \rho g h b + \frac{\rho g (H - h) b}{2} = U_{tail} + u$$

$$M = \frac{\rho g h b^2}{2} + \frac{\rho g (H - h) b^2}{3} = M_{tail} + m$$



$$U_{min} = \rho g h b + 0 = U_{tail} + 0$$

$$M_{min} = \frac{\rho g h b^2}{2} + 0 = M_{tail} + 0$$



$$U = \rho g h b + \rho g (H - h) b = U_{tail} + u \cdot 2$$

$$M = \frac{\rho g h b^2}{2} + \frac{\rho g (H - h) b^2}{2} = M_{tail} + m \cdot 1,5$$

Figure 6-15 - Influence of physical restraints on uplift and moment.

6.5 Ice loads

This section gives only a summary of ice loads for the purpose of assigning a probability distribution for further calculations and should not be considered complete.

The magnitude of the ice load depends on the velocity and magnitude of the ice movement towards a structure, as well as on the mechanical properties of the ice and extent of restraint from shores etc. The mechanical properties depend on, among other things;

- Type of ice (sea ice, lake ice or river ice)
- Formation development (primary/secondary ice, with or without snow, frazil or not etc)
- Extent of cracking

6.5.1 Reason for ice loads

Ice movement occur due to temperature changes, water level fluctuations, wind, currents etc. Three main reasons for ice loads can be distinguished:

- Ice loads due to cracking –freezing.

The underside of the ice is in contact with water and will have a temperature of 0° C. If the upper side of an ice cover is cooled, that part will contract, while the under side still has a temperature of 0° C and resumes its length. This gives rise to bending moment in the ice, but since it is floating on water bending is restricted and stresses will be released by the formation of deep cracks. Cracks will be filled by water, slurry or snow and the freezing, with volume increase, will cause pressures in the ice cover. If the temperature change is very slow the ice will deform viscously without formation of cracks (Bergdahl 1977a).

- Ice loads due to increasing temperature in the ice cover.

Ice, like any material, expands during heating. The heat expansion coefficient is about 5 times that for steel (Ekström, 2002) and a temperature increase of 20 ° C will cause a 1 km long ice sheet to expand about 1m (ICOLD bulletin 105, 1996). When the free expansion is restricted by restraint from structures or shoreline, stresses will develop in the ice and give rise to forces of considerable magnitude.

The force depends on rate of change of temperature in the ice, the coefficient of thermal expansion, rheology of the ice, the extent to which cracks have been filled, thickness of the ice cover, degree of restriction from shores, rate of change of weater conditions; wind speed, air temperature, solar radiation, depth of snow etc (Ekström, 2002). For pure thermal events the ice loads increase steadily during the period of increasing temperature, see Figure 6-16.

Ice loads generated by ice temperature increase in combination with water level changes.

Water level fluctuations in combination with thermal loads with distinct (but not excessive) water level changes, result in ice loads much larger and more variable than “pure” thermal ice loads (Comfort et al., 2003). Figure 6-17 shows the steady increase of loads due to thermal changes and the spikes are due to water level changes.

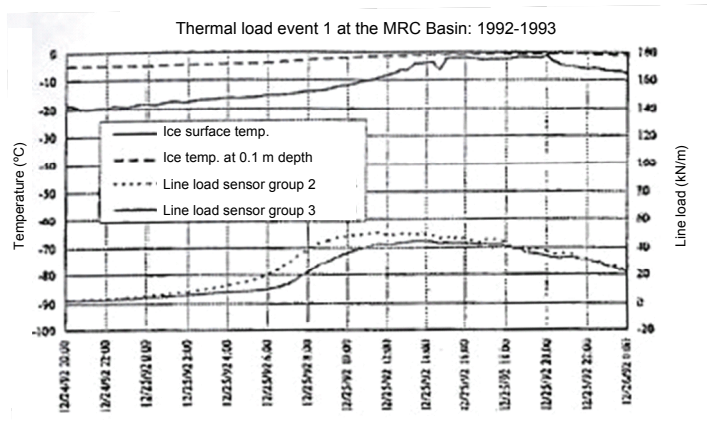


Figure 6-16 - Loads for pure thermal events. From Comfort et al. (2003).

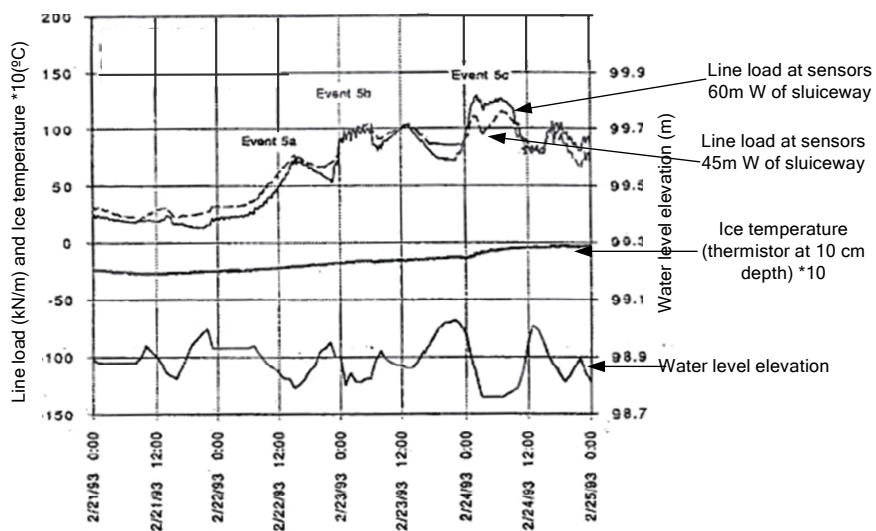


Figure 6-17 - Loads for combined thermal and water level changes. Comfort et al. (2003)

Loads induced by increasing temperature are in general larger than that due to cracking and freezing and the discussion to follow is focused on this.

6.5.2 Creep

The ice strength is significantly lower in case of slow loading compared to quick loading. In case of slow movements the contact pressure is limited by creep (BYGG, 1985).

When strain rate is low, ice can creep indefinitely without breaking because of recrystallization. When subject to rapid deformation it becomes as breakable as glass and splits into small pieces (ICOLD, 1996).

The deformation of a loaded ice specimen can be divided into three separate parts; elastic deformation, recoverable creep and irrecoverable creep. Figure 6-18 shows an idealized graph over the deformation following instantaneous loading and unloading of a sample. When loaded there appears elastic deformation, ϵ_e , which is completely recovered when the sample is unloaded. The recoverable creep, ϵ_d , is recovered after some time, while the irrecoverable creep, ϵ_y , is permanent deformation.

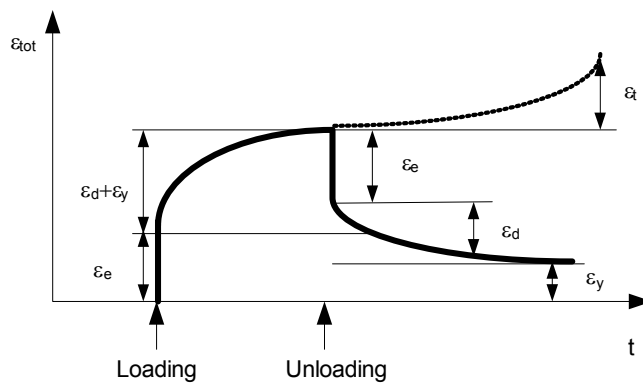


Figure 6-18 - Idealized deformation-time curve for ice body loaded and unloaded momentarily. After Ekström (2002) from Loset et al. (1998).

Bergdahl (1977a) uses, with reference to other authors, a non-linear rheological model of ice deformations.

6.5.3 Time of peak loads

Ice loads can be produced in early season when there is no or little snow cover, but they tend to be low. Larger loads are produced in late winter due to extended heating periods (Comfort et al., 2003, ICOLD, 1996). Comfort et al. (2003) found a strong relationship between thermal loads and the change in ice temperature area ΔA , see Figure 6-19 and Figure 6-20. They discovered that snowfalls contributed greatly to thermal loads by the insulation they added to the ice surface, causing rapid warming from the “bottom up”. Snowfalls initiated or contributed to 70 % of the thermal events noted. Long durations were required to cause large ice temperature changes and events with large ΔA tended to be of longer duration. When comparing events of the same ΔA but with different duration, lower loads were seen for the longer duration. This may be due to creep.

Larger ice thickness give larger ΔA and thus produce higher loads. There is less stress redistribution due to creep in thick ice which also give higher loads.

As summarized in Ekström (2002), Fransson & Cederwall (1984) found in field measurement of ice loads on bridge pillars that one of the most important load cases is

flooding of cold ice due to water level increase. The water, with temperature of zero degree C, give quick heating of the ice cover with resulting thermal expansion.

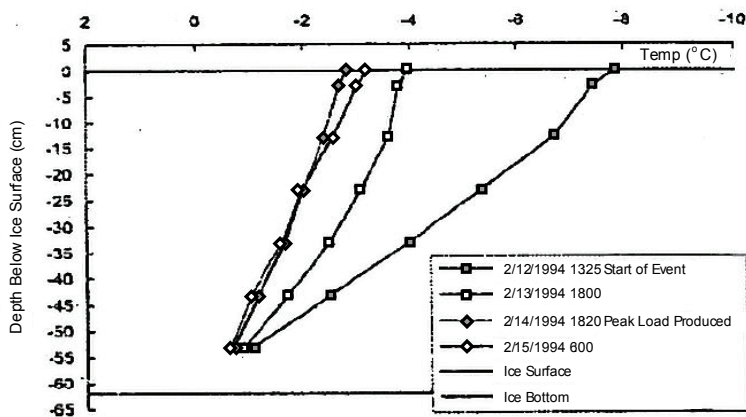


Figure 6-19 - Ice temperature profile changes for highest thermal load. From Comfort et al. (2003).

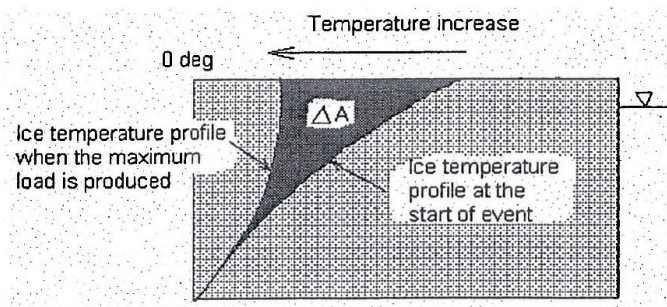


Figure 6-20 - Schematic picture of temperature profile changes. From Comfort et al. (2003).

6.5.4 Other considerations

- The failure mode will have impact on the load. Izumiyama, Irani & Timco (1994) (summarized by Ekström, 2002) showed that high loading rate gave crushing of the ice, while low loading rate caused buckling of the ice.
- When the ice freeze to a structure, water level changes may also cause vertical forces (ICOLD, 1996).
- Narrow structures will be exposed to larger forces than wide structures.
- Flexible structures between rigid ones will exhibit lower loads. This is of importance for spillway gates.

- Structures with vertical sides will exhibit higher ice loads than those with sloping sides, as the ice may bend and “follow” the structure.
- Ice loads measured in situ are often smaller than those measured in laboratory, probably due to extensive cracking in the ice cover.

6.5.5 Testing and modelling

Løset et al. (1998) (summarized by Ekström 2002) mention that laboratory tests, full-scale tests and theoretical modelling have to be combined to estimate the ice load on a structure.

6.5.5.1. Laboratory tests

Laboratory tests give important information of ice loads as the parameters affecting it can be controlled, but results are difficult to use for in situ ice.

Laboratory tests on small samples can not be used directly as the variable texture, thermal gradients, imperfections, impurities and biaxial state of stress of natural ice is largely varying (ICOLD, 1996).

Tests on small samples may give compressive strength of 5-10 MPa while in situ testing with natural blocks give 0.5-2 MPa (Ekström, 2002). Because of the anisotropy, with large crystals of varying orientation, imperfections and impurities, the mechanical properties vary significantly when testing in situ, even for blocks taken close to each other.

6.5.5.2. Field measurement

Field measurements could be thought to be the most reliable way to determine ice loads, but due to the nature of ice loads it is not (Løset et al., 1998, summarized by Ekström 2002). It is impossible to know all parameters of interest as they all vary at the same time, different failure modes affect each other and the result and it is extremely difficult to distinguish ice loads due to thermal events from those due to water level increase etc.

6.5.5.3. Theoretical modelling

Ekström (2002) and ICOLD (1996) both refer to several modelling attempts. There are, according to Løset et al. (1998) (summarized by Ekström 2002), no constitutive model that takes account of all parameters and can be used for numerical modelling.

Ashton (1986, according to Ekström, 2002) propose that a statistical analysis of ice loads is possible to perform by gathering data of ice characteristics and weather conditions and by performing numerical calculations of ice temperature and pressure based on rheological relationship. Bergdahl & Wernersson (1978) established a complete energy balance for the ice cover by using weather and ice data from 5 Swedish lakes. The weather parameters used were air temperature, extreme air temperature, wind speed, cloud cover and air vapour pressure. From weather information they calculated ice loads for a number of years and fitted statistical distributions to the results. They found that the normal or lognormal distribution was the best, but the series was too short

for the method used and the results can therefore be questioned. Even so, this represents one of few (if any) attempts to describe ice loads in terms of statistical distributions. Cox (summarized by Ekström, 2002) showed that the results from Bergdahl & Wernersson (1978) were conservative as it did not account for the stress distribution in the ice cover prior to the thermal event, and the parameters of the rheological model were a bit too conservative.

There are several more attempts to model ice loads, but as pointed out by Ashton (summarized by Ekström, 2002) they (including that by Bergdahl & Wernersson) give good approximations of thermal ice loads in an ice cover without cracks.

Ekström (2002) mentions several attempts to model ice loads by Finite element models, combined finite element and finite difference models, linear fracture mechanics etc.

Comfort et al. (2003) proposed an empirical model for the ice loads as

$$LL_{total} = LL_{residual} + \Delta LL_{thermal} + \Delta LL_{Water\ level} + \Delta LL_{contingency} \quad (6.22)$$

where LL_{total} is the total ice load, $LL_{residual}$ is the residual ice load, i.e. the ice load in the ice prior to the event, $\Delta LL_{thermal}$ is the “pure” thermal load, $\Delta LL_{Water\ level}$ is the ice load due to water level changes and $\Delta LL_{contingency}$ is a contingency to account for modelling errors and uncertainties. Equations for calculation of all loads are given in their paper. By use of long-term information of temperature, rain and snow etc, the thermal ice load on a dam can be calculated. Their model was derived on the basis of long time in situ monitoring.

6.5.6 Load values

From the above summary it is obvious that a reliable statistical description of ice loads is not easily established.

In RIDAS TA (2008) the design ice loads is set to:

	Ice load [kN/m]	Ice thickness [m]
Sothern Sweden (Skåne, Blekinge, Halland, Bohuslän and Västergötland)	50	0.6
North of southern Sweden, up to a line between Stockholm - Karlstad	100	0.6
North of a line between Stockholm - Karlstad	200	1.0

As design in RIDAS is based on a safety factor, it is, however, not stated what those values represent. It is likely some kind of “maximum values”, but if they correspond to characteristic values (50 year return period) or something else is not known.

According to ICOLD (1996) the Swedish design values are, just as former URSS and Norwegian design values, based on the work by Starosolsky (1970). This work has not been studied here. The design values given in ICOLD (1996) (for Canada, USA, URSS,

Norway, Sweden, Japan and China) are between $90 \cdot h$ (Norway) and $300 \cdot h$ (Siberia in URSS, China and by some Canadian/American standard). h is the maximum thickness of the ice cover. In this respect the Swedish values seem to be within the same bounds as are considered reasonable in other parts of the world as well.

According to Bergdahl & Wernersson (1978) the calculated ice loads for 100, 500 and 1000 year return period was 480, 509 and 520 kN/m for Torne träsk. For Runn (in Dalarna) the values were 353, 381 and 392 kN/m. Those values are significantly higher than in RIDAS. Log-normal distributions gave the best fit to the ice loads calculated by Bergdahl & Wernersson.

Comfort et al. (2003) reported ice loads due to thermal events of up to 85 kN/m (McArthur Falls Dam) and for thermal events and water level changes the highest load measured was 374 kN/m (Seven Sisters Dam). The only information found where statistical distributions were presented was that by Bergdahl & Wernersson (1978) and results from a master thesis (Fredriksson & Persson, 2005). In the master thesis temperature data from 40 years was used to simulate temperature for a 1000 year period using the Autoregressive Moving Average model. Ice growth was then simulated with and without snow cover on the ice. Loads were calculated according to

$$P = E \cdot \Delta T \cdot h \cdot \alpha \quad (6.23)$$

where E is the modulus of elasticity, ΔT is the temperature difference between the start and the end of an event, α is the heat expansion coefficient and h the ice thickness. The modulus of elasticity is very difficult to estimate. For short periods of loading $E = E_0 / 2$ was assumed and for long periods $E = E_0 / 4$ was used (due to creep). $E_0 = 6.5 \cdot (1 - 0.012 \cdot T_{average}) \cdot 10^9$ was used.

Ice loads were calculated for long and short time loads for ice with snow (the whole season) and without snow (the whole season). The result was fitted to Gumbel distributions.

The model to predict ice loads is perhaps too simplified to give accurate results of maximum ice loads, but the input data was from real temperature data and for this reason the coefficients of variation are considered representative. The simulation resulted in V_x ranging from 0.29 to 0.46 (8 values).

The modelling by Bergdahl & Wernersson (1978) give ice loads much higher than those received by others, but the procedure is thought to be valid. The high values are (according to Ashton, see Ekström 2002) thought to be the results of the modulus of elasticity being too high. In Bergdahl & Wernersson V_x ranged from 0.15 to 0.4.

6.5.7 Distribution used

It is extremely difficult to estimate a statistical distribution for ice loads as there is not sufficient data available and further research is needed. For the papers in this thesis, a Lognormal distribution was assumed and 200 kN/m was assumed to correspond to a 50 year value. If this is correct the value in RIDAS represent a characteristic value

according to the partial factor format. In this case the ice load is $I \sim \text{LN}(126; 31.5)$ as shown in Figure 6-21.

This assumption on ice is based on engineering judgement considering the previous literature study, but should not be used in a real assessment situation without further investigation. The basis for this choice is that

- 200 kN/m is the value used in RIDAS.
- Most countries use ice loads of around 200 kN/m (Ekström, 2002 and ICOLD, 1996).
- V_x was assumed to be 0.25. According to Bergdahl & Wernersson (1978) and Fredriksson & Persson (2005) the V_x may be even higher (above 0.4), which would give $I \sim \text{LN}(97.7; 39)$.

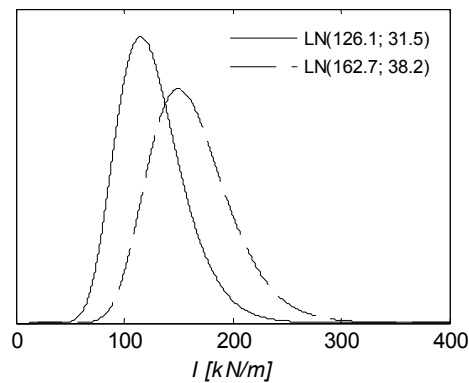


Figure 6-21 - Distribution of ice load, $I \sim \text{LN}(126; 31.5)$ and $I \sim \text{LN}(162.7; 38.2)$.

In Paper II an ice load $I \sim \text{LN}(162.7; 38.2)$ was also used to investigate the impact of large ice load. For this distribution $P(I > 200) = 0.157$

For the purpose of this thesis it is assumed that the ice loads above include both thermal loads and loads from any water level changes.

In future applications it seems wise to distinguish different cases for a specific dam, depending on the characteristics of operation and reservoir, related to the combination of thermal and water level fluctuations. The following is based on Comfort et al. (2003).

- Steady drawdown of the reservoir head. Broke the ice away from the dam and caused low loads.
- Large one-time drop or rise (i.e. more than ice thickness). Gave lower or no loads during the rest of the season.
- Large and frequent water level changes. Gave low loads as the water level changes inhibited the formation of a strong bond between ice and dam. Produced hinge-shaped ice cracks.

- Intermediate water level changes. Caused the highest ice loads because ice cracks and ice cover conditions that greatly resisted ice sheet movements were produced. Vertical cracks with a great deal of new ice growth.
- Small and slow water level changes. Ice loads were produced primarily by thermal events.

The type of water level fluctuation at the specific dam should be possible to use in the analysis of the ice loads. In this way conservative values would not have to be assumed for dams where it is not necessary to ensure stability of dams where higher ice loads are possible.

Ice loads may be avoided by e.g. building inclined structures (allowing the ice to break), heating structures (often applied to steel gates) or adding air bubbles to the water (avoiding it from freezing).

6.6 System

The system previously defined, shown in Figure 4-13 has to be updated due to

1. The treatment of head water as

$$h_w = h_{rwl} + d_e \quad (6.24)$$

where

$$d_e \sim \begin{cases} 0 & | h_w \leq h_{rwl} & \text{normal case} \\ \text{Exp}(\lambda) & | h_w > h_{rwl} & \text{exceptional case} \end{cases} \quad (6.25)$$

which resulted in a series system. The normal case is combined with ice load. Water levels above rwl are not combined with ice load, as the ice is expected to break for increasing water levels and flood situations occur in other seasons than ice.

2. The behaviour of uplift in case of $h_w > h_{rwl}$, where the limit state function is a

$$\text{function of } U_d \cdot \min \left\{ \alpha \cdot \left(\frac{d_e}{h_{rwl}} \right)^2 + \gamma \cdot C + \varepsilon, 2 \right\} \text{ which resulted in a parallel}$$

system. Similar description is valid for all failure modes related to the foundation or interface.

The final system is now given according to Figure 6-22. As before OR gates indicate series system behaviour (i.e. when one component fail the structure fail) and AND gates indicate parallel system behaviour (i.e. both has to fail for the system to fail).

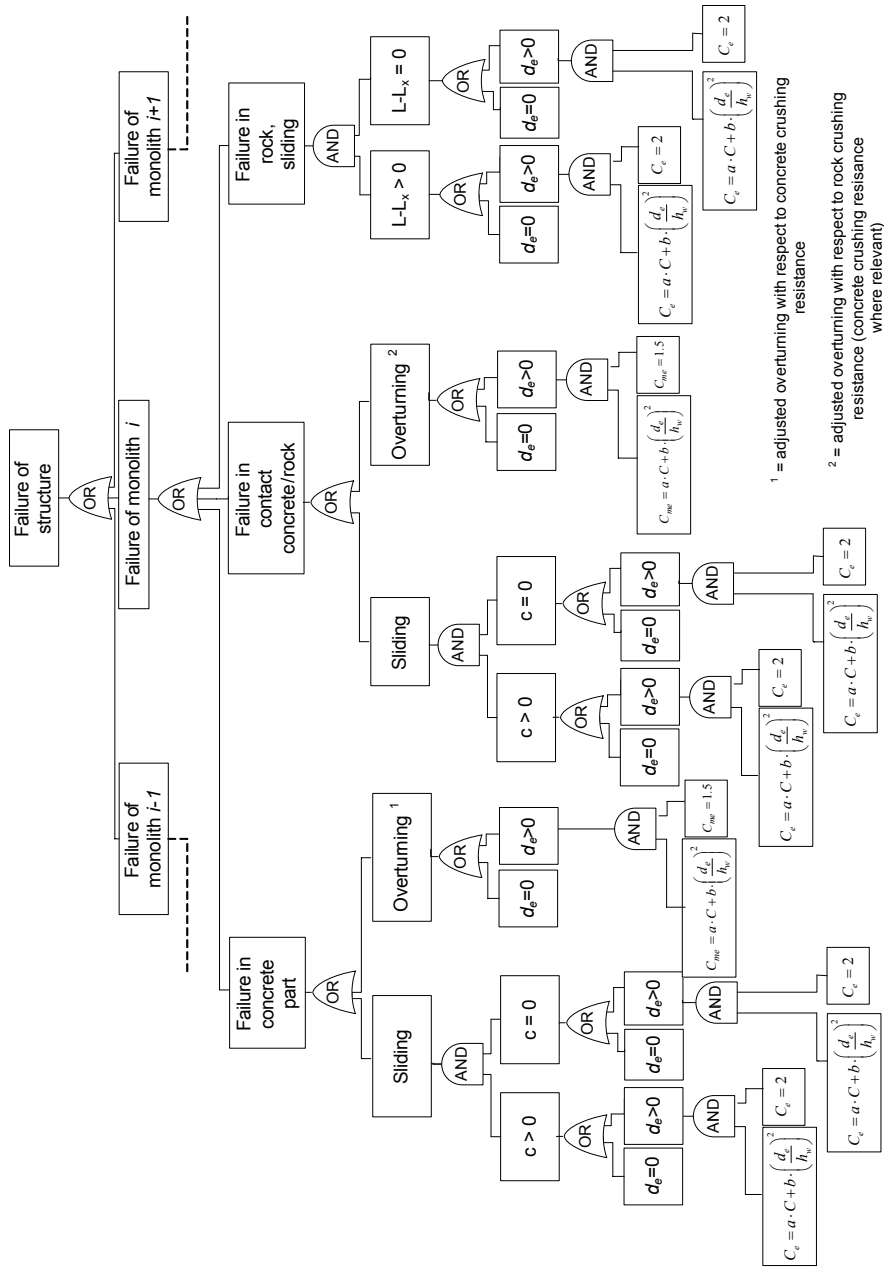


Figure 6-22 - Final system of failure modes.

7. Short summaries of appended papers

Five papers are appended to this thesis. In the first two the system reliability of concrete dam structures is calculated and the following three treat modelling of uplift pressure.

Paper I

Westberg, M. C. & Johansson, F. System Reliability of Concrete Spillway with respect to foundation stability - application to a spillway. Submitted to Journal of Geotechnical and Geoenvironmental Engineering.

In this paper a system reliability analysis of a concrete spillway structure consisting of two monoliths is performed. Input data is based on testing and literature survey and the failure modes analysed are sliding in the concrete-rock interface, sliding in the rock mass and adjusted overturning. The safety index for each failure mode and monolith is determined by FORM and the system reliability is approximated by integration, taking into account the correlation between failure modes and monoliths. The system safety is found to be governed by a persistent rock joint beneath one monolith and system reliability analysis is found useful in the dam risk management process.

Paper II

Westberg, M.C. (2009) Reliability Analysis of Idealized dam and Power Intake Structure. In Proceedings of the 10th International Conference on Structural Safety and Reliability, Osaka, Japan.

In this paper a structural reliability analysis of an idealized dam, that is safe according to the current Swedish guidelines, is performed. A structural reliability analysis of a power intake structure where pre-stressed rock anchors have been installed to increase the stability is also presented. The results show that the most important parameters are friction angle and cohesion of the concrete-rock interface and that if the cohesion is medium-high, the safety is sufficient, while for low cohesion the safety is insufficient.

Paper III

Westberg, M. (2009) Geostatistical approach for statistical description of uplift pressures: Part I. Dam Engineering 19 (4): 241–256.

This paper presents a methodology where the hydraulic conductivity beneath a concrete dam is described by a geostatistical approach. Points close to each other are more likely to have similar values than points far apart. This spatial dependence is described using a variogram. For a given realization of a the 2D hydraulic conductivity field beneath the dam (in this case the horizontal section), a FE-analysis is used to derive the uplift pressure, uplift force and uplift moment. Results are presented in Paper IV.

Paper IV

Westberg, M. (2009) *Geostatistical approach for statistical description of uplift pressures: Part II. Dam Engineering 20 (1): 39–58.*

This paper presents results of simulations using the methodology described in Paper III. Since no information of mean value, variance or range is available a large sensitivity analysis is performed, with 29 different combinations of variance and range. A Monte Carlo simulation is performed for each combination. It is found that uplift is can be described by the assumption usually used in design, multiplied by a random variable, C . Due to physical limitations C varies between 0-2. Similarly, for the moment of uplift pressure, a random variable C_m that varies between 0-1.5, is defined. The conclusion is that the methodology is useful and gives valuable statistical descriptions of the uplift pressure, that may be used as input when performing structural reliability analysis.

Paper V

Westberg, M. C. & Celestino, T.B. *Variogram Estimation of Hydraulic Conductivity Field Based on Water Pressure Tests for Probabilistic Evaluation of Uplift Pressure. Submitted to Computers and Geotechnics.*

In this paper, results from water pressure tests for a Brazilian dam founded on basalt is used to estimate the hydraulic conductivity. The hydraulic conductivity field is found possible to describe by a variogram with variance, range and nugget. A Monte Carlo simulation is performed, where uplift pressure for the intake structure is solved for 1300 possible realizations of the hydraulic conductivity field using 2D FE-analyses. The approach is similar to that described in Paper III and IV, but here the hydraulic conductivity field is that for a vertical section. The total uplift force is found to have a normal distribution. The most probable hydraulic conductivity field is identified by comparison to uplift monitoring results. It is concluded that the uplift is likely to be about 5% higher than that obtained with the design assumptions usually adopted. The methodology is found very useful.

Other publications

Bernstone, C., Westberg, M. & Jeppsson, J. (2009). Structural Assessment of a Concrete Dam Based on Uplift Pressure Monitoring. *Journal of Geotechnical and Geoenvironmental Engineering*. ASCE. 133-142.

Westberg, M. (2009). Structural reliability analysis of concrete dams – theory and case study. Proceedings of 23rd ICOLD Congress, Brasilia, Brasil.

Westberg, M. (2008). Structural reliability analysis of concrete dams – design concepts. Proceedings of Nordic Concrete Research Meeting, Bålsta, Sweden.

7. *Short summaries of appended papers*

Westberg, M (2007). Hydrostatic Pressure, Uplift Pressure and Their Combined Action in Structural Reliability Analysis. Proceedings of International Symposium on Modern Technology of Dams, Chengdu, China.

Westberg, M (2006). Structural Reliability Analysis of Concrete Dams – Geostatistical Approach to Describe Uplift Pressures. Hydropower 2006 International Conference, Kunming, China.

Westberg, M. & Bernstone, C. (2005). *Updated Reliability Analysis of Concrete Dam Based on Monitoring of Uplift Pressure*. Proceedings of Nordic Concrete Research Meeting, Sandefjord, Norway. Norsk Betongforening.



8. Conclusions

Structural reliability analysis may be used for analysis of dams in the assessment phase. Since every dam is a unique prototype and reliability-based analysis enables the specific behaviour and properties of a certain structure to be taken into consideration, the result may in many cases be very satisfactory, in terms of reduced uncertainties and thus increased safety, and identification of the most important parameters. This was clearly shown in Paper I and Paper II.

Structural reliability analysis is well fitted for use in the dam safety risk management process. As this concerns the risk of the whole dam facility system, a system reliability analysis, where all parts are considered as a system, gives an excellent input to a quantitative risk analysis. It should, however, be noted that the safety index or probability of failure is nominal.

Great difficulty is associated with limit state formulation and definition of statistical distributions of the random variables. In this thesis limit states formulation is defined in accordance with recent research, based on the mechanical behaviour.

- The modelling and simulation described for uplift pressure is shown to be powerful, as it gives a possible statistical distribution of uplift force and moment. By analysing the basaltic foundation of a dam site it is shown that the properties of the hydraulic conductivity on site may be described geostatistically by a variogram and the simulated uplift agrees very well with that measured. As input in the reliability analysis, uplift variability is a necessity and it is not possible to estimate in any other way.
- The treatment of head water level as series system of water at retention water level, and above retention water level with a low probability of occurrence, also proved useful.
- The system of failure modes is also new, and a useful tool in understanding relationship between the different failure modes and descriptions of loads. This also makes it possible to calculate the safety index for the whole structure, thus giving an estimate of the overall structural safety.

8.1 General safety considerations

Safety is, and should be, given highest priority in dam engineering. The stability criteria, and thus safety, of concrete dams is based on safety factors, where one safety factor is used for each criterion. This type of design formulation was used for other types of structures as well, but during the 1970's and 1980's the partial factor format was introduced. This format takes into account the statistical variability of loads and resistance and the partial factors that are assigned to the different variables differ in size depending on the variability of the parameter. In this way the safety of structures becomes more uniform, and resources are likely to be spent more efficiently. The partial

factors are calibrated by a reliability-based methodology, as was discussed in chapter 3. There is still conservatism inherent in the partial factor format, and when complex structures are designed, or when safety assessment is performed for existing structures, use of reliability-based methods is advantageous. Reliability-based methodology offers the possibility of rational integration of information of a certain object and refinement of statistical descriptions of loads and resistances, e.g. based on monitoring and testing.

The safety format used today is deterministic and as such it only tells us that a dam is “safe” or “unsafe”, but nothing of how safe, how un-safe etc. As was discovered in the 1970s the use of only one safety factor results in some structures to be much safer than others, when safety is given a probabilistic interpretation. The master thesis work by Ahlsén Farell & Holmberg (2007) indicates that the safety of dams is dependant on dam height, dam type and failure mode, which is exactly the situation we do not want.

We have to ask the question: how do we want our dams? The answer to this question is that we want them to be

- Safe “enough”
- Equally safe, the safety level for dams of a specified consequence class should be independent of dam height and dam type

If design and assessment should be based on the partial factor format some of the problems described above would be possible to “cure”. As each dam is a unique prototype there is a danger that such format would result in very large partial factors, as guidelines are often made general to be applicable to a large number of structures. In that case one further possibility is to base design and assessment directly on reliability based methodology. This means that statistical description of loads and resistance would have to be performed for each dam structure. It may be based on some general description, but would have to be adapted to every single structure, which is cumbersome and sometimes difficult. The advantage would be that all dam structures would have the “right” safety.

Development of the safety format has the possibility to give us:

- Different safety for different consequence classes. Target safety can be differentiated for different consequence classes, and if partial factors are used they can be related to different consequence class
- Uniform safety for each consequence class, independent of dam height, dam type and failure mode.

8.2 Further research needs

Clearly, several benefits can be gained by introducing reliability-based analysis for assessment, and perhaps also design, of concrete dams. There are, however, several obstacles that need to be solved to present a methodology useful on large scale for assessment of concrete dam structures, and to formulate new guidelines for assessment

and design, and the below areas need attention to various extent. These steps are also necessary if a partial factor format is to be introduced.

- Shear resistance parameters. May cohesion be modelled by a brittle parallel system? What is the expected value and variance? What may affect this? How large parts of the area has cohesion? How can results from the small test samples be included and used for updating of a priori assumptions? How large part of the normal force contributes to the shear resistance? Can shear resistance without cohesion be added to shear resistance with cohesion (when only part of the area is bonded)?
- Drain effectiveness. How can drain effectiveness be proved adequate? How large effect does this have on the safety?
- Bayesian updating of prior distributions of random variables, how can that be conducted for test results, monitoring, proof loading etc?
- Model uncertainties. How large are the model uncertainties? How should they be modelled?
- Ice loads, what is the statistical distribution? How can this be described for different reservoir conditions (water level variations, inclination of beaches etc)?
- Target safety index. How should this be defined? Who should do it?
- How and when is Finite Element Reliability Analysis necessary? What else is needed to do such analysis?
- How should combinations of different effects be described? Examples are temperature and uplift, ice and uplift, crushing of rock/concrete and sliding, uplift and head water level etc.
- Systematic analysis of several objects. This is very important to develop the methodology and gain knowledge on important/less important variable

9. References

- Ahlsén Farell, L & Holmberg, J (2007). *Utvärdering av säkerhet för betongdammar*. Master thesis. Avd för Konstruktionsteknik. Lund University. TVBK-5150. ISSN 0349-4969. In Swedish.
- Ale, B.J.M. (2005). Tolerable or Acceptable: *A comparison of Risk Regulation in the United Kingdom and in the Netherlands*. Risk Analysis. 25 (2) 231-241.
- Altarejos, L. , Escuder, I., Membrillera, M.G. & Serrano, A. (2009). *Risk analysis and probability of failure of a gravity dam*. Proceedings from ICOLD Conference, Brasilia.
- Ang, A. & Tang, W. (1975) *Probability Concepts in Engineering Planning and Design*. Volume I, Basic Principles. John Wiley & Sons, Inc. New York.
- Araújo, J.M. & Awruch, A.M. (1998) *Probabilistic finite element analysis of concrete gravity dams*. Advances in Engineering Software, Vol 29, No. 2, p 97-104.
- Bandis, S., Lumsden, A.C. & Barton, N.R. (1981) *Experimental Studies of Scale Effects on the shear behaviour of rock joints*. Int. J. Rock. Mech., Min. Sci. & Geomech. Abstr. Vol 18 pp 1-21.
- Baylous, R. & Bennett, R. (1989) *Safety Assessment of an Existing Concrete Gravity Dam*. Structural Safety and Reliability, Proceedings of Fifth International Conference on Structural Safety and Reliability, ASCE, 279-286.
- BBK 94 (1995) *Boverkets handbok om betongkonstruktioner*. The Swedish National Board of Housing, Building and Planning.. In Swedish.
- BBK 04 (2004) *Boverkets handbok om betongkonstruktioner*. The Swedish National Board of Housing, Building and Planning.. In Swedish.
- Bergdahl, L & Wernersson, L (1978) *Calculated and expected thermal ice pressures in five Swedish lakes*. Department of Hydraulics, Chalmers University of Technology, Sweden. ISSN 0348-1069.
- Bergdahl, L. (1977a) *Physics of Ice and Snow as Affects thermal pressure*. Department of Hydraulics, Chalmers University of Technology, Sweden.
- Bergström, S. (1993) *Sveriges hydrologi – grundläggande hydrologiska förhållanden*. Norrköping: SMHI/Svenska Hydrologiska Rådet.
- Bernstone, C. (2006). *Automated performance monitoring of concrete dams*. Doctoral thesis. Engineering geology, Faculty of Engineering, Lund University. ISBN 91-628-6982-5.
- Bernstone, C. , Westberg, M. & Jeppsson, J. (2009) Structural Assessment of a concrete Dam Based on Uplift Pressure Monitoring. *Journal of Geotechnical and Geoenvironmental Engineering*. 135:1 (133-142).

Berntsson, S. (2001). *Dam safety and risk management*. Licentiate Thesis, Department of Civil and Environmental Engineering, Royal Institute of Technology, Stockholm, Sweden. ISSN: 1400-1292.

Betonghandbok Konstruktion (1990). AB Svensk Byggtjänst och Cementa AB, Örebro. ISBN 91-7332-533-3.

BKR (2003). Boverkets konstruktionsregler. ISBN 91-7147-740-3. ISSN 1100-0856.

Brandesten, C-O. & Engström Meyer, A. (2008) *Manual for dam safety*. Internal Vattenfall document.

Bureau of Reclamation (1987) Design of Small Dams.
http://www.usbr.gov/pmts/hydraulics_lab/pubs/manuals/SmallDams.pdf

Bury, K.V. & Kreuzer, H. (1985). Assessing the failure probability of gravity dams. *Water Power & Dam Construction*. November 1985.

BYGG, Handboken (1985). ISBN 91-38-06081-7

Canadian Dam Safety Association (1995) *Dam safety guidelines*.

Carlsson, F., Thelandersson, S. (2006) *Probabilistisk modellering samt säkerhetsprinciper för befintliga broar*, Rapport TVBK-3052, Div. of Structural Engineering, Lund University, 164 p. In Swedish.

Carvajal C., Peyras L., Bécue J-P., Varon C., Bacconnet C., Clergue D., Boissier D. (2006) *Towards a probabilistic assessment of structural safety of gravity dams*. 14th German Dam Symposium, 7th European Club of International Commission on Large Dams (ICOLD), Munich (Germany), CD Rom (8p.), 17-19 September 2007.

CEB-FIP Model Code 1990 (1991), Comité Euro-International du Béton. *Bulletin d'information*, No. 213/214, Lausanne.

Cederström, M. (2009) *Personal communication*.

China Electric Council (2000) *The Standards Compilation of Water Power in China*. China Electric Power Press, Beijing. ISBN 7-5083-0392-X.

CIB (1989) *Actions on structures. Self-weight loads*. Report by CIB Commission W81.

Comfort, G., Gong, Y., Liddiard, A. (2003). *Static ice loads on dams*. Proceedings from ICOLD Congress, Montreal 2003.

CUR Publicatie 190 (2006) *Probability in Civil Engineering, Part 1, the theory of probabilistic design*. March 1997, Stichting CUR, Gouda, The Netherlands.

Douglas, K., Spannagle, M. and Fell, R. (1999) Analysis of Concrete and Masonry Dam Incidents. *The International Journal on Hydropower & Dams*. 6(4), pp.108-115.

Du, C. (2009) Arch action in concrete dams with straight axis. *Dam Engineering*. ISSN 0-617-00563-X, Vol XX, Issue 2.

- Efstratidos, N., Ghiocel, C. & Singhal, S. (2005) *Engineering Design Reliability handbook*. ISBN 0-8493-1180-2
- Ekström, T (2002). *Islaster mot hydrauliska konstruktioner. Inriktning mot betongdammar*. Elforsk rapport 02:03. In Swedish.
- Ellingwood, B. (2009) *Role of modeling uncertainties in assessing vulnerability and risk to civil infrastructure from rare events*. Proceedings of the Tenth International Conference on Structural Safety and Reliability (ICOSSAR).
- Ellingwood, B. & Tekie, P.B. (2001) *Fragility analysis of concrete gravity dams*. Journal of infrastructure systems, June 2001. ASCE, ISSN 1076-0342.
- EN1990. (2004) Eurocode – Basis of structural design. CEN, Brussels.
- EN1992 (2007). *Eurocode 2: Design of concrete structures – Part 1: General rules for buildings*. CEN, Brussels.
- EPRI – Electric Power Research Institute (1992). *Uplift Pressures, Shear Strengths, and Tensile Strengths for Stability Analysis of Concrete Gravity Dams. Volume 1. Final Report*. Stone and Webster Engineering Corporation, Denver, Colorado, USA. Report EPRI TR-100345
- Faber, M. H. (2001). *Risk and Safety in Civil Engineering*. Lecture notes. Swiss Federal Institute of Technology.
- FEMA (2007) *Federal Guidelines for Dam Safety*. <http://www.fema.gov/hazard/damfailure/why.shtm> (2007-01-02)
- FERC (2002) *Engineering Guidelines for the Evaluation of Hydropower Projects*, Chapter III Gravity dams. <http://www.ferc.gov/industries/hydropower/safety/guidelines/eng-guide.asp#skipnavsub>
- Fishman, Y.A. (2007) *Features of shear failure of brittle materials and concrete structures on rock foundations*. International Journal of Rock Mechanics and Mining Sciences V. 45, p. 976-922.
- Fishman, Y.A. (2008) *Features of compressive failure of brittle materials*. International Journal of Rock Mechanics and Mining Sciences 45 (2008) 993-998.
- Fishman, Y.A. (2009) *Stability of concrete retaining structures and their interface with rock foundations*. International Journal of Rock Mechanics and Mining Sciences V. 46, p. 957-966.
- Flödeskommittén (1990, 2007) *Riktlinjer för bestämning av dimensionerande flöden för dammanläggningar*. Slutrapport från Flödeskommittén. Statens Vattenfallsverk, Svenska Kraftverksföreningen & Sveriges Meteorologiska och Hydrologiska Institut. In Swedish.
- Foster, J.L. (1989a) *Uplift under concrete dams on rocks*. Water Power, pp.322-331.

-
- Foster, J.L. (1989b). *Uplift criteria for existing concrete gravity dams, past present and future*. Proceedings of the American Power Conference, pp. 766-771.
- Fredriksson, M & Persson, J. (2005) *Modellering av extrema istryck – studie av Pajala och Frösön*. Master thesis. Avd för Konstruktionsteknik och Teknisk Vattenresurslära. Lunds Tekniska Högskola, Lund, Sweden. TVBK-5131. In Swedish.
- Grenoble, B.A., Harris, C.W., Meisenheimer, J.K. and Morris, D.I.(1995) *Influence of rock joint deformations on uplift pressure in concrete gravity dam foundations: Field measurements and interpretation*. Fractured and Jointed Rock Masses, Myer, Cook, Goodman & Tsang (eds). 1995 Balkema, Rotterdam. ISBN 90 5410 591 7.
- Guidicini, G. & Andrade, R.M. (1988) *Seasonal uplift pressure in hydraulic structure foundation due to environmental thermal variations*. Rock Mechanics and Power Plants, Balkema, Rotterdam, ISBN 90 6191 8278, pp 467-471
- Gustafsson, A., Johansson, F., Rytters, K. & Stille, H. (2008) *Betongdammars glidstabilitet – förslag på nya riktlinjer*. Elforsk Rapport 08:59. In Swedish. English translation of title: Sliding stability of concrete dams – suggestion for new guidelines.
- Hansson, S.O. (2002). *Philosophical Perspectives on Risk*. Speech at conference Research in Ethics and Engineering, Delft university. www.infra.kth.se/~soh
- Hartford, D.N.D. & Baecher, G. B. (2004) *Risk and uncertainty in dam safety*. Tomas Telford Limited, Great Britan. ISBN: 0 7277 3270 6.
- Hartford, D.N.D. (2006) *On the harmonization of qualitative and quantitative risk assessment arguments in safety decisions pertaining to earthfill dams*. Proceedings from ICOLD Congress, Barcelona, June 2006.
- Hasofer, A.M. & Lind, N.C (1973) *An exact and invariant first-order reliability format*. Solid mechanics division, University of Waterloo, Waterloo; Ontario, Canada. Paper No. 19, May 1973.
- Hohenbichler & Rackwitz (1981). *On structural reliability of parallel systems*. Reliability Engineering 2: 1-6.
- Hohenbichler & Rackwitz (1982) *First-order concepts in system reliability*. Structural Safety. 1: 177-188.
- Hornik (2006) *The R FAQ*. ISBN 3-900051-08-9. <http://CRAN.R-project.org/doc/FAQ/R-FAQ.html>
- HSE (2001) *Reducing risks, protecting people*. Health & Safety Executive, United Kingdom. ISBN 0 7176 2151 0.
- ICOLD (1987) Bulletin 59: *Dam Safety guidelines*. International Commission on large dams, Paris.
- ICOLD (1993) Bulletin 88: *Rock foundations for dams*. International Commission on large dams, Paris.

- ICOLD (1995) Bulletin 99: *Dam failures – statistical analysis*. International Commission on large dams, Paris.
- ICOLD (1998) Bulletin 111: *Dam-break flood analysis*. International Commission on large dams, Paris.
- ICOLD (2005) Bulletin 130: *Risk Assessment in Dam Safety Management*. International Commission on large dams, Paris.
- ICOLD (1996). Bulletin 105 *Dams and related structures in cold climate. Design guidelines and case studies*. International Commission on large dams, Paris.
- ICOLD (1992) Bulletin 82. *Selection of design flood*.
- IEC:1995 (1995) International standard 300-3-9. Part 3: application guide – Section 9: Risk analysis of technological systems. CEI 1995.
- IRGC (2006) *White paper on risk governance*. International risk governance council, Geneva. Printed Sept 2005, reprinted Jan 2006.
- Jackson, D.C. (2003) *It is a crime to design a dam without considering upward pressure: Engineers and uplift, 1890-1930*. In Darcy and Hydraulics, pp 220-232.
- JCSS (2001) *Probabilistic model code*. <http://www.jcss.ethz.ch/>
- JCSS (2001b) *Probabilistic assessment of Existing structures*. RILEM Publications SARL. 161p. ISBN 2-912143-24-1.
- Jeppsson, J. (2003) *Reliability –based assessment procedures for existing concrete structures*. Doctoral Thesis. Lund University, Division of Structural Engineering. Report TVBK-1026, Lund, Sweden.
- Johansson, F. (2005). *Stability analyses of large structures founded on rock – an introductory study*. Licentiate Thesis in Soil and Rock Mechanics. Stockholm, Sweden. ISSN 1650-951X.
- Johansson, F. (2009) *Shear Strength of Unfilled and Rough Rock Joints in Sliding Stability Analysis of Concrete Dams*. PhD Thesis, Division of Soil and Rock Mechanics, Royal Institute of Technology, Stockholm, Sweden.
- Kemikontoret (2001) *Riskhantering 3 – Tekniska riskanalyismetoder*. Kemikontoret, Stockholm. In Swedish.
- Kolluru R (1996): *Risk Assessment and Management Handbook*. McGraw-Hill Inc. New York.
- Krüger, C.M., Neto, A.C. & Krüger, D.A.V. (2009). *Structural reliability analysis – a framework for roller-compacted concrete dams*. ICOLD Congress, Brasilia, May 2009.
- Ljungqvist, K. (2005) *A probabilistic approach to risk analysis. A comparison between undesirable indoor events and human sensitivity*. Doctoral thesis, Luleå University of Technology, Sweden. ISSN: 1402-1544.

-
- Lo, K.Y., Lukajic, B., Wang, S., Ogawa, T. & Tsui, K.K. (1990). *Evaluation of Strength Parameters of Concrete-Rock Interface for Dam Safety Assessment*. In Proc. of Canadian Dam Safety. Conference.
- Lo, K.Y., Ogawa, T., Lukajic, B., Dupak, D.D (1991). Measurements of Strength Parameters of Concrete-Rock Contact at the Dam-Foundation Interface. *Geotechnical Testing Journal*. Vol. 14, No. 4, pp. 383-394.
- Lo, K.Y. & Grass, J.D. (1994) Recent experience with safety assessment of concrete dams on rock foundations. *Dam safety* p 231-250.
- Lupoi & Callari (2009) *Probabilistic Seismic Assessment of Concrete dams*. Proceedings of the tenth international Conference on Structural Safety and Reliability
- Melchers R.E. (1999) *Structural Reliability Analysis and Prediction*. Second Edition. John Wiley & Sons. ISBN 0-471-98771-9.
- Mill, O. (2008). *Dammsäkerhet i Sverige*. Course material from Dammar & Dammsäkerhet. In Swedish.
- NKB 1995:02E (1995) *Basis of design of structures. Calibration of partial factors*. Nordic committee on Building Regulations. Monila Oy, Helsinki 1996. ISBN 951-53-0617-5.
- NKB 55E (1987) *Guidelines for loading and safety regulations for structural design*. Nordiska kommittén för byggbestämmelser. ISSN 0359-9981.
- Paté-Cornell (1994) *Quantitative safety goals for risk management of industrial facilities*. *Structural Safety* 13(3): 145-157.
- Ramsberg, J. (2000) *Comments on Bohnenblust and Slovic, and Vrijling, van Hengel and Houben*. *Reliability engineering and system safety* 67, p 205-209.
- RCP Consult (1997). *STRUREL, A Structural Reliability Analysis Program System, COMREL & SYSREL Users Manual*. RCP GmbH Barer Strasse 50, 80799 München, Germany.
- Reinius, E. (1962/1982) *Vattenbyggnad del 3 – Dambyggnader*. In Swedish.
- RIDAS (2008) *Kraftföretagens riktlinjer för dammsäkerhet (Swedish Hydropower companies guidelines for dam safety)*. Svensk Energi. In Swedish.
- RIDAS TA (2008). *Kraftföretagens riktlinjer för dammsäkerhet, tillämpningshänvisningar (Swedish Hydropower companies guidelines for dam safety, application guideline)*. Svensk Energi. In Swedish.
- Royet, P., Peyras, L., Becue, J.P & Carvajal, C. (2009). *Analytical review of gravity dam stability: from novel French limit-state guidelines to a probabilistic assessment of structural safety*. ICOLD Congress, Brasilia, May 2009.
- Ruggeri et al (2004) *Sliding stability of existing gravity dams – Final report*. ICOLD European Club. <http://cnpqb.inag.pt/IcoldClub/index.htm> under working groups.

- Ruggeri, G & European Working group (2001). *Uplift Pressures under Concrete Dams – Final report*. In Procs. From ICOLD European Symposium in Geiranger, 2001. <http://cnpgeb.inag.pt/IcoldClub/index.htm> under working groups
- Räddningsverket (1997) *Värdering av risk*. Statens räddningsverk, Karlstad, Risk- och miljöavdelningen, ISBN 91-88890-82-1.
- Saouma, V. (2006). *Reliability based nonlinear fracture mechanics analysis of a concrete dam; a simplified approach*. Dam Engineering Vol XVI, Issue 3.
- Schlather, M.(2001) *Simulation of stationary and isotropic random fields*. _R-News_*1*(2), 18-20.
- Schneider, J. 1997) Introduction to Safety and Reliability of Structures. IABSE document, www.iabse.ethz.ch.
- SS-EN 1050:1996 (1996) *Maskinsäkerhet – Principer för riskbedömning*. <http://www.sp.se/Electronics/RnD/projects/MaskinStandard/Standards/1050.htm>. In Swedish.
- Stille, H., Andersson, J. & Olsson, L. (2003). *Information based design in rock engineering*. SveBeFo Rapport 61. ISSN 1104-1773.
- Taylor, D.W. (1948) *Fundamentals of soil mechanics*. John Wiley & Sons, USA.
- Tekie, P.B. & Ellingwood, B.R. (2003) *Seismic fragility assessment of concrete gravity dams*. Earthquake engineering and structural dynamics. 32: 221-2240.
- The MathWorks, Inc. *Matlab 7.3.0*. www.mathworks.com
- Thelandersson, S. (2004). *Assessment of material property data for structural analysis of nuclear containments*. Report TVBK-3051, Division of Structural Engineering, Lund University, Sweden.
- Thoft-Christensen, P. and Baker, M. J. (1982). *Structural Reliability and Theory and its Applications*. Springer-Verlag. Berlin, Heidelberg, New York.
- U.S. Army Corps of Engineers (2003) *Gravity dam design – Engineering guideline*.
- Waarts, P.H.(2000).*Structural reliability using Finite Element Analysis*. Doctoral Thesis, Delft University, Delft, The Netherlands. ISBN 90-407-2073-8.
- Vatn (1998) *A discussion of the acceptable risk problem*. Reliability Engineering and System Safety 61, p 11-19.
- Vattenfall (2006). Handbok dammsäkerhet. Internal Vattenfall document.
- Vattenfall (2000). Risk analysis Ajaure. Internal Vattenfall document.
- Westberg, M. (2007) *Reliability-based evaluation of concrete dams*. Licentiate thesis. Division of Structural Engineering, Lund Institute of Technology, Lund University. Report TVBK-1033.

-
- Westberg, M. (2009) Geostatistical approach for statistical description of uplift pressures: Part I. *Dam Engineering*, Vol XIX, Issue 4.
- Westberg, M. (2009) Geostatistical approach for statistical description of uplift pressures: Part II. *Dam Engineering*, Vol XIX, Issue 4.
- Westberg, M.C. (2009) *Reliability analysis of idealized dam and power intake structure*. Proceedings of the tenth international conference on structural safety and reliability (ICOSSAR 2009), Osaka, Japan, 13-17 September 2009.
- Vrijling & van Gelder (1998) *The effect of inherent uncertainty in time and space on the reliability of flood prediction*. Safety and Reliability, Lyckersen, Hansen & Sandov (eds). ISBN 90 5410 966 1. Balkema, Rotterdam.
- Vrijling, J.K, van Hengel, W. & Houben, R.J. (2000) *Response to comments by J. Ramsberg on the paper Acceptable risk as a basis for design*. Reliability Engineering and System Safety. (67) 211-212.
- Vrijling, J.K, van Hengel, W. & Houben, R.J.(1998) *Acceptable risk as a basis for design*. Reliability Engineering and System Safety (59) 141-150.
- Vrouwenvelder, T., Lovegrove, R., Holicky, M., Tanner, P. & Canisius, G. (2001) *Risk assessment and risk communication in civil engineering*. Safety, Risk, reliability - trends in engineering. Malta 2001.