



# LUND UNIVERSITY

## Characterization and Enhancement of Antenna System Performance in Compact MIMO Terminals

Plicanic, Vanja

2011

[Link to publication](#)

*Citation for published version (APA):*

Plicanic, V. (2011). *Characterization and Enhancement of Antenna System Performance in Compact MIMO Terminals*. [Doctoral Thesis (compilation), Department of Electrical and Information Technology].

*Total number of authors:*

1

### General rights

Unless other specific re-use rights are stated the following general rights apply:

Copyright and moral rights for the publications made accessible in the public portal are retained by the authors and/or other copyright owners and it is a condition of accessing publications that users recognise and abide by the legal requirements associated with these rights.

- Users may download and print one copy of any publication from the public portal for the purpose of private study or research.
- You may not further distribute the material or use it for any profit-making activity or commercial gain
- You may freely distribute the URL identifying the publication in the public portal

Read more about Creative commons licenses: <https://creativecommons.org/licenses/>

### Take down policy

If you believe that this document breaches copyright please contact us providing details, and we will remove access to the work immediately and investigate your claim.

LUND UNIVERSITY

PO Box 117  
221 00 Lund  
+46 46-222 00 00



**Characterization and Enhancement of  
Antenna System Performance in  
Compact MIMO Terminals**

Vanja Plicanic

Doctoral Dissertation

Dept. of Electrical and Information Technology  
Lund University  
Lund 2011

Department of Electrical and Information Technology  
Lund University  
Box 118, SE-221 00 LUND  
SWEDEN

This thesis is set in Computer Modern 10pt  
with the L<sup>A</sup>T<sub>E</sub>X Documentation System

Series of licentiate and doctoral theses  
No. 30  
ISSN 1654-790X  
ISBN: 978-91-7473-120-0

© Vanja Plicanic 2011  
Printed in Sweden by *Tryckeriet i E-huset*, Lund.  
May 2011.

*Ad rem!*  
(Latin: To the point!)



# Abstract

Co-band multiple-antenna implementation in compact user terminals is necessary for harvesting the full potential of diversity and multiple-input multiple-output (MIMO) technology in cellular communication systems. The recent worldwide deployment of Long Term Evolution (LTE), which requires the use of MIMO technology in the downlink, adds to the urgency of achieving both practical and optimal multiple-antenna systems in user terminals. Contrary to conventional understanding, an optimal multiple-antenna implementation does not only involve the design and placement of antenna elements in the terminals, but extends beyond the antenna elements and common antenna parameters to comprise interactions with the near field user and the propagation environment. Moreover, these interactions are non-static, which implies that the multiple-antenna system must adapt to the prevailing overall communication channel in order to assure the highest performance gains. This doctoral thesis aims to address several key issues in optimal multiple-antenna system design for compact multi-band MIMO terminals, with the first half (Papers I to III) focusing on the performance characterization of such terminals in the presence of user interaction and propagation channel, under the challenging constraint that the terminals are compact. The second half of the thesis (Papers IV to VI) considers two performance enhancement approaches suitable for compact MIMO terminals in realistic usage conditions. In particular, the potential benefits of harmonizing compact multiple-antenna systems with the propagation channel and user influence are determined with respect to reconfigurability in antenna patterns and impedance matching circuits.

In Paper I, the diversity performance of internal multiple antennas with multi-band coverage in a mock-up with the size of a typical mobile handset is investigated in different user interaction scenarios. For comparison, a second mock-up with only one multi-band antenna is also evaluated in the same user cases. An ideal uniform propagation environment is assumed. The performance at frequency bands below and above 1 GHz are presented and analyzed in detail.

Paper II extends the study in Paper I by evaluating the single-input

multiple-output (SIMO) and MIMO capacity performance of the same antenna prototypes under the same user interaction scenarios and propagation environment.

In Paper III, the impacts of gain imbalance and antenna separation on the throughput performance of a dual-dipole configuration are studied at frequencies below and above 1 GHz in a repeatable dynamic multi-path environment, using a live HSPA network. Since the compactness of a user terminal has implications on the antenna separation and gain imbalance of the multiple antennas, the focus is to gain knowledge on how these two factors affect the end user experience in practice.

In Paper IV, three simple dual-antenna topologies implemented in compact smart phone prototypes of identical form factors are evaluated in MIMO channel measurements in noise-limited and interference-limited urban scenarios. Each dual-antenna topology is intentionally designed to provide a distinct set of antenna patterns. The goal is to investigate the potential of antenna system design as one of the key performance differentiators in real terminal implementations.

Paper V extends the work in Paper IV by introducing user interaction to the same MIMO channel measurement setup. Furthermore, the focus of this paper is on the evaluation of both the average and local channel performances and their potential enhancements.

Finally, Paper VI ascertains the potential capacity gains of applying uncoupled adaptive matching to a compact dual-antenna terminal in an indoor office environment, under a realistic user scenario. The performance gains are evaluated by means of extensive MIMO channel measurements at frequency bands below and above 1 GHz.

# Preface

This doctoral thesis is an anthology of six research papers that summarizes the research work conducted during my Ph.D. study at the Department of Electrical and Information Technology, Lund University and at Sony Ericsson Mobile Communications AB, Lund. The thesis is organized into two parts: the first part provides an introduction to the research field and summarizes in context the main scientific contributions, and the second part comprises the research papers in their published or submitted format. The included research papers are:

- V. Plicanic, B. K. Lau, A. Derneryd, and Z. Ying, “Actual diversity performance of a multiband diversity antenna with hand and head effects,” *IEEE Trans. Antennas Propag.*, vol. 57, no. 5, pp. 1547-1556, May 2009.
- V. Plicanic Samuelsson, B. K. Lau, A. Derneryd, and Z. Ying, “Channel capacity performance of multi-band dual antenna in proximity of a user,” in *Proc. IEEE Int. Workshop Antenna Technol. (IWAT’2009)*, Santa Monica, CA, USA, Mar. 2-4, 2009, pp. 5-8.
- V. Plicanic and B. K. Lau, “Impact of spacing and gain imbalance between two dipoles on HSPA throughput performance,” *Electron. Lett.*, vol. 45, no. 21, pp. 1063-1065, Oct. 2009.
- V. Plicanic, B. K. Lau, and H. Asplund, “Experimental evaluation of MIMO terminal antenna configurations in noise- and interference-limited urban scenarios,” in *Proc. European Conf. on Antennas and Propag. (EuCAP’2011)*, Rome, Italy, Apr.11-15, 2011, pp. 2909-2913.
- V. Plicanic, H. Asplund, and B. K. Lau, “Performance of handheld MIMO terminals in noise- and interference-limited urban macrocellular scenarios,” *submitted to IEEE Trans. Antennas Propag.*, 2011.

- V. Plicanic, I. Vasilev, R. Tian, and B. K. Lau, “On capacity maximisation of a handheld MIMO terminal with adaptive matching in an indoor environment,” *submitted to Electron. Lett.*, 2011.

During the graduate study, I have also participated in other closely related research activities. The resulting publications, though they are not included in this thesis, are listed in the following:

- V. Plicanic, B. K. Lau, and Z. Ying, “Performance of a multiband diversity antenna with hand effects,” *in Proc. IEEE Int. Workshop Antenna Technol. (IWAT’2008)*, Chiba, Japan, Mar. 4-6, 2008, pp. 534-537.
- V. Plicanic, M. Zhu, and B. K. Lau, “Diversity mechanisms and MIMO throughput performance of a compact six-port dielectric resonator antenna array,” *in Proc. IEEE Int. Workshop Antenna Technol. (IWAT’2010)*, Lisbon, Portugal, Mar. 1-3, 2010.
- R. Tian, V. Plicanic, B. K. Lau, and Z. Ying, “A compact six-port dielectric resonator antenna array: MIMO channel measurements and performance analysis,” *IEEE Trans. Antennas Propag.*, vol. 58, no. 4, pp. 1369-1379, Apr. 2010.

The research results throughout the graduate study have also been presented and discussed as temporary documents (TDs) in the European Cooperation in Science and Technology (COST) Action 2100 (Dec. 2006 - Dec. 2010). As a result of my active participation, I have been invited to write the section “*Practical considerations for compact terminal antenna systems*” within Chapter 4 of the COST2100 Final Report. The COST2100 Final Report will be published as a book:

- R. Verdone and A. Zanella, *Pervasive Mobile & Ambient Wireless Communications - The COST Action 2100*, Springer, in press.

# Acknowledgements

I love a challenge. Being an industrial Ph.D. student with one foot in the industry and one in the academia has indeed been a challenge. Nevertheless, it has also been an experience that I have fully enjoyed for the last four and the half years. I am very grateful for the opportunity to be part of the two worlds, to explore and to hopefully add value to both of them. This has been a very exciting professional and a personal journey for me. There are a number of people to whom I would like to express my gratitude, for making this journey even better than I imagined.

I would like to thank my main advisor Dr. Buon Kiong Lau for his firm commitment and endless support. I am grateful for his guidance and constructive criticism, which have added a new dimension in my way of thinking and have highly improved the quality of my scientific work and my scientific writing. His extensive knowledge of the research field, ambition and professionalism are a great source of inspiration for me. I would also like to thank my co-advisors Dr. Anders Derneryd and Prof. Gerhard Kristensson for all the fruitful discussions and the scientific guidance and tools they have provided me. My gratitude goes also to Prof. Jørgen B. Andersen from Aalborg University and Prof. Michael A. Jensen from Brigham Young University for the valuable discussions and the feedback that they have provided me on some parts of my work. I am grateful for the opportunity to have interacted with and learnt from all these knowledgeable and experienced researchers.

My gratitude goes to Sony Ericsson Mobile Communications AB (SEMC) that has sponsored and fully supported the work. In specific, I would like to thank my former manager Thomas Bolin and my current manager Dr. Peter C. Karlsson who have entrusted me with the lead of this research project and who have enabled vital technical support and encouragement. Together with my research colleague Zhinong Ying they have early on envisioned the need for this particular research topic and have always been great advocates of it.

Great appreciation goes to the people that have throughout my graduate study offered me their technical support and expertise in many fruitful col-

laborations and discussions. They are: Henrik Asplund, Dr. Jonas Fridén and Dr. Andres Reial from Ericsson Research Kista, Gothenburg and Lund, respectively, Robert Blaser, Richard Wittmer and Jesse Schwartz from former RNC Lab in Ericsson AB, Research Triangle Park, USA, and my former SEMC colleagues Rodney Williams, Osamu Kozakai and Stan Disbrow.

Special thanks goes to my colleague and officemate at the faculty department, Ruiyuan Tian, for all the productive discussions and the support that he has provided throughout the years. It was great fun and a pleasure sharing the workspace with you. Many thanks also goes to the latest group member Ivaylo Vasilev, who has in his short stay already proved to be a good team player and a great support. I am looking forward to our future collaboration. I sincerely thank all my colleagues at the Department of Electrical and Information Technology (EIT) and at SEMC who have provided great help with all the "small" things that really matter and made my time at the department and the office very enjoyable.

Finally, my most special and boundless gratitude goes to my husband Ola and my family. They have without doubt been my greatest cheerleaders, with my mother Greta in the forefront. We have all made a great spiritual journey together that has enriched both my personal and my professional life and will continue to do so. I am forever grateful for that.

The industrial Ph.D. work was conducted under and supported by VINNOVA grants 2007-01377 and 2009-02969.

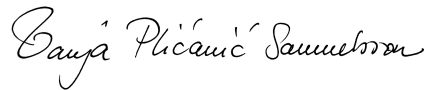

Vanja Plicanic Samuelsson

# List of Acronyms and Abbreviations

**ADG** Actual Diversity Gain

**APS** Angular Power Spectrum

**AoA** Angle of Arrival

**AoD** Angle of Departure

**BF** Beamforming

**BS** Base Station

**CENELEC** Comité Européen de Normalisation Électrotechnique

**CTIA** Cellular Telecommunications & Internet Association

**DG** Diversity Gain

**DL** Downlink

**EDG** Effective Diversity Gain

**EGC** Equal Gain Combining

**Ev-Do** Evolution-Data Optimized

**FS** Free Space

**GSM** Global System for Mobile Communications

**HSPA** High Speed Packet Access

**IEC** International Electrotechnical Commission

**IEEE** Institute of Electrical and Electronics Engineers

**IL** Interference-Limited

**INR** Interference-to-Noise Ratio

**ISI** Inter-Symbol Interference

**LOS** Line-of-Sight

**LTE** Long Term Evolution

**MEG** Mean Effective Gain

**MIMO** Multiple-Input Multiple-Output

**MRC** Maximum Ratio Combining

**MISO** Multiple-Input Single-Output

**NL** Noise-Limited

**NLOS** Non-Line-of-Sight

**OTA** Over-the-Air

**PDC** Personal Digital Cellular

**PER** Packet Error Rate

**RSSI** Received Signal Strength Indicator

**RF** Radio Frequency

**RX** Receive

**SAM** Specific Anthropomorphic Mannequin

**SCM** Spatial Channel Model

**SIMO** Single-Input Multiple-Output

**SINR** Signal-to-Interference-plus-Noise Ratio

**SIR** Signal-to-Interference Ratio

**SISO** Single-Input Single-Output

**SM** Spatial Multiplexing

**SNR** Signal-to-Noise Ratio

**TIS** Total Isotropic Sensitivity

**TRP** Total Radiated Power

**TX** Transmit

**UE** User Equipment

**UMTS** Universal Mobile Telecommunications System

**VNA** Vector Network Analyzer

**WCDMA** Wideband Code Division Multiple Access

**WiMAX** Worldwide Interoperability for Microwave Access

**WINNER** Wireless World Initiative New Radio

**XPR** Cross Polarization Ratio

**3D** Three-Dimensional

**3G** Third Generation

**3GPP** Third Generation Partnership Project

**4G** Fourth Generation



# Contents

<b>Abstract</b>	<b>v</b>
<b>Preface</b>	<b>vii</b>
<b>Acknowledgements</b>	<b>ix</b>
<b>List of Acronyms and Abbreviations</b>	<b>xi</b>
<b>Contents</b>	<b>xv</b>
<b>I Overview of the Research Field</b>	<b>1</b>
<b>1 Introduction</b>	<b>3</b>
<b>2 Multiple-Antenna Performance Characterization</b>	<b>9</b>
2.1 Diversity Performance . . . . .	10
2.1.1 Branch Power Imbalance . . . . .	10
2.1.2 Correlation . . . . .	12
2.1.3 Diversity Gain . . . . .	13
2.1.4 Actual Diversity Gain . . . . .	14
2.1.5 SIMO Capacity . . . . .	15
2.2 MIMO Performance . . . . .	15
2.2.1 Channel Gain . . . . .	16
2.2.2 Eigenvalue Dispersion . . . . .	16
2.2.3 MIMO Capacity . . . . .	17
2.3 Throughput . . . . .	19
<b>3 Multiple Antennas in Compact Terminals</b>	<b>21</b>
3.1 Compactness . . . . .	22

3.2	Near Field User Interaction . . . . .	25
3.3	Propagation Channel . . . . .	26
<b>4</b>	<b>Enhancement of Multiple-Antenna Performances</b>	<b>29</b>
4.1	Antenna Decoupling Techniques . . . . .	30
4.2	Channel Adaptiveness . . . . .	30
<b>5</b>	<b>Contributions and Conclusions</b>	<b>33</b>
5.1	Research Contributions . . . . .	33
5.1.1	PAPER I: “Actual Diversity Performance of a Multiband Diversity Antenna with Hand and Head Effects” . . . . .	33
5.1.2	PAPER II: “Channel Capacity Performance of Multiband Dual Antenna in Proximity of a User” . . . . .	34
5.1.3	PAPER III: “Impact of Spacing and Gain Imbalance between Two Dipoles on HSPA Throughput Performance” . . . . .	35
5.1.4	PAPER IV: “Experimental Evaluation of MIMO terminal Antenna Configurations in Noise- and Interference-limited Urban Scenarios” . . . . .	36
5.1.5	PAPER V: “Performance of Handheld MIMO Terminals in Noise- and Interference-limited Urban Macrocellular Scenarios” . . . . .	37
5.1.6	PAPER VI: “On Capacity Maximization of a Handheld MIMO Terminal with Adaptive Matching in an Indoor Environment” . . . . .	38
5.2	Conclusions and Future Work . . . . .	39
	<b>References</b>	<b>41</b>
<b>II</b>	<b>Included Research Papers</b>	<b>47</b>

## Part I

# Overview of the Research Field



# Chapter 1

## Introduction

The unquenchable thirst for ever increasing wireless data transfer rates is challenging the wireless communication community to evolve existing communication systems and introduce better candidate solutions in future standards. In particular, the long term aim to expand *cellular* wireless communications beyond conventional circuit-switched services has resulted in the new third generation (3G) standard releases: High Speed Packet Access (HSPA) (Release 5-6) and HSPA Evolution (Release 7-8) for the Third Generation Partnership Project (3GPP) standardization track, and Evolution-Data Optimized (Ev-Do) for the 3GPP2 standardization track. Moreover, fully packet-oriented systems, Long Term Evolution (LTE) from 3GPP (Release 8-9) and Worldwide Interoperability for Microwave Access (WiMAX) (Institute of Electrical and Electronics Engineers (IEEE) 802.16 standard), which are considered the predecessors of fourth generation (4G) cellular systems, are currently being deployed around the world [1–4].

Today, multiple-antenna technologies have matured enough to become an increasingly prevalent solution in both existing and upcoming wireless communication systems for leveraging high data rates, as well as ensuring reliable link connections and good coverage. In the early days, multiple antennas and appropriate intelligent algorithms to combine the receive (RX) signals have been applied at only one link end, *e.g.*, at the base stations (BSs) in the cellular systems. The main purpose is to increase the reliability of signal reception. However, in the late 1990's, a second RX antenna and selection combining was incorporated into the user equipment (UE) for the Japanese Personal Digital Cellular (PDC) system as a requirement for combating inter-symbol interference (ISI) [5], [6]. No requirement on an additional radio frequency (RF) path enabled a low cost alternative for link quality improvement in that particular

system. Multiple antenna elements at both link ends, accompanied by more sophisticated algorithms, are presently the key technology in evolved 3G and 4G systems. For example, the implementation of dual RX antennas is available as an option for UEs in the HSPA family of standards (3GPP Release 6 and onwards) and it is the minimum requirement in the LTE cellular communication system (from 3GPP Release 8 and onwards) [2]. Since it is far more challenging to implement multiple antennas in compact UEs, in comparison to significantly larger BSs, much of the current research interest is on designing multiple antennas for UEs [7].

The concept of multiple antennas originates from the research work on physically separated antennas in the 1920's and 1930's [8], [9], where it was observed that the received signal fluctuations at different antennas were statistically independent of one another. It was demonstrated that selecting the antenna with the strongest signal at the receiver at each time instant reduced the negative effect of multi-path fading on the overall received signal over time. Hence, the *selection RX diversity* technique was born. By the late 1960's, the choice of linear signal combining methods was expanded to include *maximum ratio combining* (MRC) and *equal gain combining* (EGC) [10], which further improve the average received signal level (*i.e.*, due to array gain). With more recent developments, the concept of multiple-antenna techniques now also covers *transmit (TX) diversity*, *beamforming* (BF) and *spatial multiplexing* (SM). While TX diversity enables reliable transmissions and better cell coverage even without channel knowledge at the TX link end, spatial multiplexing facilitates multiple-data stream to be transmitted in parallel, resulting in a higher throughput. In fact, the increased throughput with spatial multiplexing is the primary reason for the popularity of multiple-antenna systems in recent years. The principle behind spatial multiplexing is the demultiplexing of a bit stream into a number of parallel streams which are then simultaneously coded (sometimes jointly), modulated and transmitted over multiple-antenna elements. Since the receiver has the knowledge of the channel through training signals, it can differentiate between co-channel signals from the RX array elements and it can therefore extract the streams before combining them into the original bit stream. Under ideal conditions, spatial multiplexing facilitates a transmission rate that is proportional to the number of TX/RX antenna pairs [11].

In short, multiple-antenna techniques have enabled the evolution of conventional *single-input single-output* (SISO) communication systems to *single-input multiple-output* (SIMO), *multiple-input single-output* (MISO) and *multiple-input multiple-output* (MIMO) systems, with multiple-antenna configurations at the RX end, TX end, and at both ends, respectively. Nevertheless, the performance benefits of multiple-antenna techniques are accompanied by significant technical challenges. One important challenge lies in the use of multiple

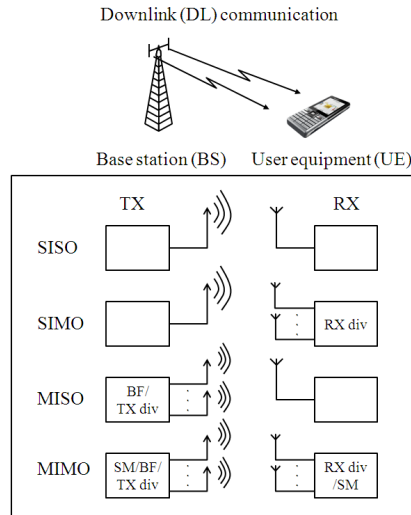

**Figure 1.1:** Downlink cellular communication with multiple-antenna techniques.

antennas in downlink (DL) cellular SIMO and MIMO setups, see Fig. 1.1. In contrast to BSs at the TX link end, UEs at the RX link end are of compact sizes. The overall size of a UE, and more strictly speaking, the restrictive volume(s) allocated for the antennas within the UE, such as a mobile phone, forces the antennas to be closely spaced. Consequently, these antennas suffer from high signal correlation and mutual coupling, which in turn limit the performance improvements of the multiple-antenna systems relative to the SISO case [7]. Moreover, the internal antennas in today's UEs are designed to cover multiple frequency bands, which due to limited implementation space can degrade the antenna efficiency and the gain balance in the multiple-antenna system. The practical utilization of UEs accounts for an additional challenge, since they are required to perform well in an arbitrary propagation environment and when handled by a user. Depending on the number of available multi-paths, their angles of departure (AoDs) and arrival (AoAs), polarization, Doppler frequency and path gains, different propagation scenarios hold different potential for diversity and spatial multiplexing gain. Moreover, the presence of user hand and body induces detuning of the antennas and absorption of the radiation power, thus affecting the efficiency and correlation performance of the antenna array. The constant mobility of the UEs when in usage further reinforces the need for sustainable performance for any user and propagation scenario.



**Figure 1.2:** From the left: three representative multiple-antenna prototypes evaluated in this thesis. First from the right: a Sony Ericsson Xperia10 smart phone shown for size comparison.

As described earlier, the concepts and principles behind the multiple-antenna techniques have been known for many years. However, the implementation of (co-band) multiple antennas as well as their performance in realistic compact UEs is a relatively new research topic. The topic involves traditionally distinct disciplines of antenna, propagation and communication theory, and hence it is interdisciplinary by nature. Moreover, the topic is also very important and practical, since it is of great interest to the worldwide wireless telecom industry, which has recently started commercializing high data rate UEs that employ MIMO technologies.

This doctoral thesis originates in early attempts by the wireless telecom industry to explore the main issues behind multiple-antenna implementations in compact terminals for diversity purposes. It eventually evolved into the distinct purpose of characterizing diversity and MIMO performance of compact terminals in realistic usage scenarios. In particular, the first half of the thesis summarizes extensive investigations that are focused on characterizing and understanding multiple-antenna systems in compact terminals (see Fig. 1.2), with and without user interaction, and in ideal and realistic propagation environments. The investigations extend beyond common antenna parameters to also encompass communication channel performance and end user experience, and thus it comprises simulations and measurements of system level parameters such as capacity and throughput for evolved 3G and 4G systems. The second half of the thesis looks into the potential of antenna system design to be

one of the key differentiators among different user terminals. The performance enhancement of multiple-antenna terminals is very much in line with the demand of the wireless telecom industry, which aims to achieve optimum designs of multiple-antenna UEs for high data rates.

The thesis presentation is organized into five chapters that introduce the field, methodology and synopsis of the work performed. This is followed by research papers that are included in this thesis in their original published or submitted format. Chapter 2 is dedicated to a brief description of several common metrics that are used to characterize the diversity and MIMO performance of multiple-antenna terminals. Chapter 3 comprises a discussion on three key challenges of implementing co-band multiple antennas in physically small terminals. Chapter 4 follows with a brief introduction of the area of performance enhancement, and it focuses on the subject of antenna system adaptivity through the use of antenna switching or adaptive matching networks. Finally, Chapter 5 summarizes the contents of the papers included in the thesis and highlights the contributions of the research performed.



## Chapter 2

# Multiple-Antenna Performance Characterization

The first step in understanding the mechanisms behind multiple-antenna implementations in compact terminals, or multiple antennas in general, is to understand the underlying performance characteristics of the antenna system. The requirements on antenna performance in user terminals in conventional cellular SISO systems are exclusively about good efficiency and omni-directional coverage. Hence, the standardized ways of characterizing the over-the-air (OTA) performance of single antenna configurations are confined to the power based metrics of efficiency, total radiated power (TRP) and total isotropic sensitivity (TIS) [12]. These parameters can be used for the estimation of the link budget and thus the cell coverage, if line-of-sight (LOS) wireless channel is assumed. Though partly useful, these parameters are not sufficient on their own for the characterization of multiple-antenna configurations. This is because multiple antennas in MIMO systems are required to facilitate spatially independent signals for the enhancement of link reliability (through diversity schemes) and/or support parallel spatial sub-channels (*i.e.*, spatial multiplexing). Moreover, the wireless channel in a cellular environment typically comprises random multi-polarized multi-path wave propagation, in which the interaction between the antenna system and the channel is decisive of the overall performance. Hence, the performance characterization needs to be further extended to cover the propagation channel, in order to accurately estimate the link budget.

This chapter takes up the task of introducing parameters which are suitable

for characterizing the interaction among the multiple antennas and between the antenna system and the surrounding channel (*i.e.*, user proximity and/or propagation channel). The focus is on the system level parameters of diversity gain, MIMO capacity and throughput, although other parameters that are helpful for acquiring important insights into the observed system performance characteristics are also described.

## 2.1 Diversity Performance

Since the focus of the research presented in this thesis is exclusively on DL multiple-antenna performance, the diversity performance discussed in this section is consequentially the RX antenna diversity. The principle of RX diversity is based on minimizing the signal-to-noise ratio (SNR) variations of the RX antenna system caused by multi-path fading. Hence, the link reliability can be improved as compared to a system with the same average SNR but with no RX diversity. The RX antenna diversity is commonly enabled through separating the radiation properties of the individual antennas in the configuration, *i.e.*, using spatial, angular and polarization diversity mechanisms. It can be utilized in both SIMO and MIMO systems to improve the overall system performance.

RX diversity can also be utilized by means of time and frequency based techniques, however, these come with the drawbacks of requiring additional time and bandwidth, as well as lacking the possibility of array gain. These techniques are omitted in the following description.

The diversity performance is dependent on two characteristics of the antenna array: the power imbalance between the antenna branches and the correlation between the signals received at the antennas.

### 2.1.1 Branch Power Imbalance

In order to achieve high diversity gain, it is important to design multiple antenna branches that provide output signals of similar average powers. Any *branch power imbalance* will cause a diversity loss proportional to the size of the imbalance between the branches (see Papers I, II and III and Fig. 2.1). Even though the imbalance can be obtained from antenna efficiencies or TRP performances, these parameters lack the directional and polarization properties of the antennas, due to the implicit assumption that the parameters are evaluated in an ideal propagation channel with 3D uniform angular power spectrum (APS). Introduced in [13], *mean effective gain* (MEG) is the preferred alternative to efficiency and TRP as a power parameter, since it accounts for possible antenna-channel mismatch and more accurately represents antenna

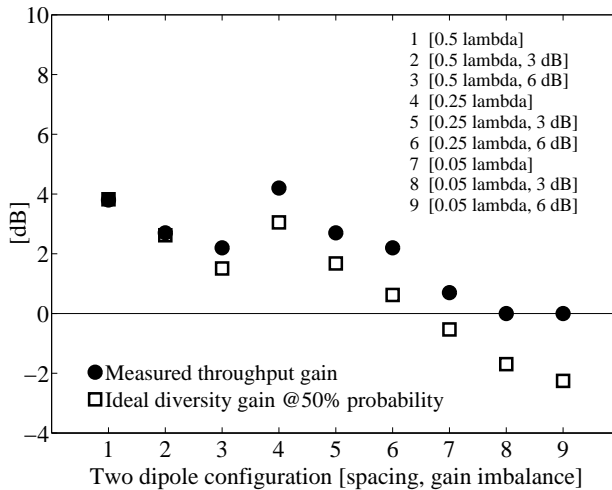

**Figure 2.1:** Impact of branch imbalance and antenna spacing on measured throughput gain in multi-path environment and calculated diversity gain in ideal isotropic propagation environment.[Paper III]

performance in non-ideal propagation environments [14]. Since the overall performance of multiple antennas is based on all the individual antenna elements and the interaction among them, each of the multiple antennas can be characterized by a MEG. The antenna branch power imbalance can then be obtained from differences among the MEGs.

## MEG

In a multi-path environment, assuming averaging over a random route, MEG is defined as the ratio between the mean received power at a mobile antenna and the total mean incident power. In spherical coordinates, MEG is given as [13]

$$MEG = \oint \left( \frac{XPR}{XPR + 1} G_{\theta}(\Omega) P_{\theta}(\Omega) + \frac{1}{XPR + 1} G_{\phi}(\Omega) P_{\phi}(\Omega) \right) d\Omega \quad (2.1)$$

where  $\Omega = (\theta, \phi)$ ,  $d\Omega = \sin\theta d\theta d\phi$ ,  $G_{\theta}(\Omega)$  and  $G_{\phi}(\Omega)$  are  $\theta$  and  $\phi$  components of the antenna gain pattern, respectively, and  $P_{\theta}(\Omega)$  and  $P_{\phi}(\Omega)$  represent the  $\theta$  and  $\phi$  components of the incident power spectrum. The antenna gain is the *realized* antenna gain, which includes mismatch, dielectric and conductive losses. The propagation properties of the incoming radio signals can be considered through the statistical power spectrum distributions of the incoming polarized

waves in elevation  $P_\theta(\Omega)$  and azimuth  $P_\phi(\Omega)$ :

$$P_\theta(\Omega) = P_\theta(\theta, \phi) = P_\theta(\theta)P_\phi(\phi) \quad (2.2)$$

$$P_\phi(\Omega) = P_\phi(\theta, \phi) = P_\phi(\theta)P_\phi(\phi) \quad (2.3)$$

Here, it is assumed that the power distributions in elevation and azimuth are separable, *i.e.*, the power distribution in elevation is independent of the distribution in azimuth. Additionally, cross polarization ratio (XPR) describes the ratio between the powers of the vertical and horizontal polarization components in the channel [13]:

$$XPR = \frac{P_\theta}{P_\phi} \quad (2.4)$$

Different propagation scenarios, such as isotropic, indoor, outdoor micro, outdoor macro can be modelled with different APSs in elevation and azimuth and different XPR distributions. A completely uniform environment (*i.e.*, isotropic) is characterized by  $XPR=1$  and  $P_\theta(\Omega) = P_\phi(\Omega) = \frac{1}{4\pi}$  [15].

### 2.1.2 Correlation

Antenna correlation describes the independency of the incoming signals at the multiple antenna ports. For the most accurate estimation of the correlation, complex signals are required. The general expression of the complex correlation coefficient, based on embedded far field patterns is given by [16]:

$$\rho_c = \frac{\oint \left( XPR \cdot E_{\theta X} E_{\theta Y}^* P_\theta + E_{\phi X} E_{\phi Y}^* P_\phi \right) d\Omega}{\sqrt{\oint \left( XPR \cdot G_{\theta X} P_\theta + G_{\phi X} P_\phi \right) d\Omega} \sqrt{\oint \left( XPR \cdot G_{\theta Y} P_\theta + G_{\phi Y} P_\phi \right) d\Omega}} \quad (2.5)$$

where  $G_{\theta,\phi}(\Omega) = E_{\theta,\phi}(\Omega) \cdot E_{\theta,\phi}^*(\Omega)$ ,  $E_{\theta,\phi X}$  and  $E_{\theta,\phi Y}$  and are the embedded, polarized complex electric field patterns of two antennas X and Y in the multiple-antenna configuration. Incident power spectrum components  $P_\theta(\Omega)$  and  $P_\phi(\Omega)$ , and XPR bring out the channel-dependency of the correlation parameter.

Conventionally in mobile communications, due to the accessibility of the envelope signals from, *e.g.*, the received signal strength indicator (RSSI) voltage, the envelope correlation coefficient is used. The envelope correlation  $\rho_e$  can be expressed as [15]:

$$\rho_e \approx |\rho_c|^2 \quad (2.6)$$

### 2.1.3 Diversity Gain

The improvement in the time-averaged SNR of the combined signal in a multiple-antenna system relative to that of the best single antenna element in the same configuration is commonly expressed in terms of *diversity gain* (DG). For the simplest combining technique, *i.e.*, the selection combining of the RX signals assuming *two* signal branches, the probability that the instantaneous SNR for the combined output is a certain value  $\gamma_c$  is given by [17]:

$$P(\gamma_c) = 1 - \exp\left(-\frac{\gamma_c}{\Gamma_X}\right)Q(A_X, B_X) - \exp\left(-\frac{\gamma_c}{\Gamma_Y}\right)(1 - Q(B_Y, A_X)) \quad (2.7)$$

where

$$A_{X,Y} = \sqrt{\frac{2\gamma_c}{\Gamma_{X,Y}(1 - |\rho_c|^2)}} \quad (2.8)$$

$$B_{X,Y} = \sqrt{\frac{2\gamma_c|\rho_c|^2}{\Gamma_{X,Y}(1 - |\rho_c|^2)}} \quad (2.9)$$

$\Gamma_X$  and  $\Gamma_Y$  are mean SNRs at the two branches, respectively, and the assumption is that  $\Gamma_X > \Gamma_Y$ .  $\rho_c$  is the complex correlation coefficient defined in (2.5) and  $Q(\bullet)$  is the Marcum Q-function.

For another combining technique, the MRC, the probability that the instantaneous SNR for the combined output is a certain value  $\gamma_c$  is expressed as [18]:

$$P(\gamma_c) = \frac{1}{\lambda_1 - \lambda_2} \left( \exp\left(\frac{\gamma_c}{\lambda_1}\right) - \exp\left(\frac{\gamma_c}{\lambda_2}\right) \right) \quad (2.10)$$

where  $\lambda_1$  and  $\lambda_2$  are the eigenvalues for the covariance matrix of complex received signals calculated as:

$$\lambda_1 = \frac{1}{2}(\Gamma_X + \Gamma_Y + \sqrt{(\Gamma_X + \Gamma_Y)^2 - 4\Gamma_X\Gamma_Y(1 - |\rho_c|^2)}) \quad (2.11)$$

$$\lambda_2 = \frac{1}{2}(\Gamma_X + \Gamma_Y - \sqrt{(\Gamma_X + \Gamma_Y)^2 - 4\Gamma_X\Gamma_Y(1 - |\rho_c|^2)}) \quad (2.12)$$

The signal improvement gained from combining signals, *i.e.*, DG, is extracted by comparing the combined output with the output from a single antenna reference at a certain signal probability  $P(\gamma_c)$ . If the reference is one of the branches at the antenna array the ratio between the combined signal and the reference signal is the *apparent* DG [15]:

$$DG = \frac{\left(\frac{\gamma_c}{\Gamma_c}\right)}{\left(\frac{\gamma}{\Gamma}\right)_{\text{best branch}}} \Big|_{P(\gamma_c)} \quad (2.13)$$

where  $\gamma_c$  and  $\gamma$  are instantaneous SNRs, and  $\Gamma_c$  and  $\Gamma$  are mean SNRs for the combined and best branch signals, respectively. Conventionally, the reference is the best performing branch in the array, *i.e.*,  $\gamma$  is the highest individual SNR in the array. If instead an antenna with 100% efficiency in free space is used as the reference, the DG metric is known as the *effective* DG (EDG), which can be calculated as [19]:

$$EDG = \frac{\left(\frac{\gamma_c}{\Gamma_c}\right)}{\left(\frac{\gamma}{\Gamma}\right)_{\text{best branch}}} \Big|_{P(\gamma_c)} \cdot e_{\text{best branch}} \quad (2.14)$$

The total efficiency  $e_{\text{best branch}}$  takes into account mismatch, dielectric, conductive and mutual coupling losses for the diversity branch with the highest SNR performance.

MEG can be used in place of mean SNR, if the noise is assumed to be the same across the antenna branches.

#### 2.1.4 Actual Diversity Gain

The diversity gain from replacing a single antenna system with a multiple-antenna system can be obtained by referring the diversity combined signal to the signal from a realistic single-antenna implementation in the same user interaction and propagation cases. In particular, this comparison would be useful to examine if the single-antenna implementation should in practice be replaced by the diversity solution. Due to its practical predisposition this diversity metric is especially suitable for designers of terminal antennas. Furthermore, the metric is a good alternative to DG and EDG, which give the two extremes in diversity performances, as described in the Paper I. *Actual diversity gain* (ADG) is formulated as [19]:

$$ADG = \frac{\left(\frac{\gamma_c}{\Gamma_c}\right)}{\left(\frac{\gamma}{\Gamma}\right)_{\text{single antenna solution}}} \Big|_{P(\gamma_c)} \quad (2.15)$$

### 2.1.5 SIMO Capacity

The concept of capacity originates in the evaluations of SISO channels. However, it has received very little attention in single-antenna characterization. The Shannon capacity for static and deterministic noise-limited channel is defined as [20]

$$C_{\text{SISO}} = \log_2(1 + SNR|h|^2) \quad (2.16)$$

where  $h$  is a single channel response, *i.e.*, complex scalar for the SISO case. The expression shows a distinct power dependency akin to the previously mentioned power metrics for single-antenna systems. However, in the multiple-antenna case, this dependency is extended to comprise the antenna system's ability to resolve different uncorrelated multi-paths of the transmitted signal. Appropriately, the capacity as a metric gives insights on the overall performance of the multiple antennas in the communication channel. The SIMO capacity in a non-fading channel is defined as [20]:

$$C_{\text{SIMO}} = \log_2\left(1 + SNR \sum_{m=1}^M |h_m|^2\right) \quad (2.17)$$

where  $h_m$  is the single channel response for the  $m$ th antenna, with  $M > 1$  antennas at the RX end.  $SNR$  is the mean SNR per received branch. The SIMO capacity in Eq. (2.17) corresponds to the MRC and hence represents an alternative metric to diversity gain, with the same combining method, when compared to a single-antenna capacity performance [20].

## 2.2 MIMO Performance

MIMO communication enables spatial multiplexing, which has the potential of increasing the capacity of the communication channel linearly with the number of distinct TX/RX antenna pairs ( $\min(M, N)$ ) without sacrificing any additional bandwidth or power. The practical realization of spatial multiplexing is however dependent on the conditions of the actual communication channel. For low SNRs, the Shannon capacity for MIMO systems, as given later in Eq. (2.20), is linearly proportional to the SNR. For high SNRs, the capacity is logarithmically proportional to the SNR. Hence, spatial multiplexing gains are less important at low SNRs as compared to high SNRs. High SNRs alone are, however, not sufficient to guarantee spatial multiplexing gain. Rich scattering in the propagation environment, which enables a channel rank of  $\min(M, N)$ , is required for  $\min(M, N)$  parallel spatial sub-channels.

In the communication system LTE (Release 8), different options of multiple-antenna techniques are implemented, in order to adapt to the different channel

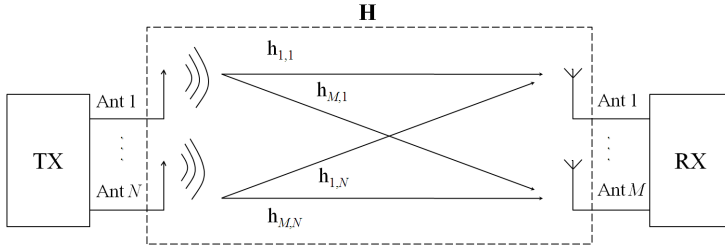

**Figure 2.2:** Downlink MIMO channel with  $M$  receive antennas and  $N$  transmit antennas.

conditions in the DL MIMO channels. For poor channel conditions with low SNR/signal-to-interference-plus-noise ratio (SINR) or low scattering (rank=1), the so called “single stream” communication is applied by combining TX BF and RX diversity. For high SINR and rich scattering (*i.e.*, full rank), the “multi-stream” communication is enabled through spatial multiplexing [2].

### 2.2.1 Channel Gain

The power and scattering that enable good MIMO capacity performance are conditioned by the characteristics of the interactions among the TX array, the propagation environment (commonly including the user), and the RX array. Hence, the appropriate power metric for the characterization of multiple antennas at the RX end of the MIMO channel that includes the aforementioned interactions is *channel gain*.

The channel gain per RX branch is obtained from the single  $M \times N$  MIMO channel response  $\mathbf{H}$  (see Fig. 2.2):

$$G_{\text{MISO}} = \left( \frac{\|\mathbf{H}\|_{\text{F}}^2}{M} \right) \quad (2.18)$$

where  $\|\bullet\|_{\text{F}}$  denotes the Frobenius norm operator. In a realistic wireless channel with channel fading, the channel gain is calculated and averaged over a number of channel responses or realizations (*e.g.*, commonly denoted as expectation  $\mathbb{E}(\bullet)$ ). This averaging step is also applicable for other figure-of-merits that will be discussed further on.

### 2.2.2 Eigenvalue Dispersion

For a full rank channel  $\mathbf{H}$  with an arbitrary SNR, the capacity performance is highly dependent on the distribution of the eigenvalues of the matrix  $\mathbf{H}\mathbf{H}^{\dagger}$  (if

$M < N$ ) or  $\mathbf{H}^\dagger \mathbf{H}$  (if  $M > N$ ). Ideally, the eigenvalues should be equally strong. However, this does not occur in practice, due to the random mixing of the signals from different TX antennas in the multi-path propagation environment before they arrive at the RX antennas. Any difference among the eigenvalues will cause gain imbalance between the parallel sub-channels, which in turn decreases the capacity. Moreover, any correlation experienced at the TX and/or RX link ends will increase the spread of the eigenvalues, which further decreases capacity.

In this thesis, the relative spread (or dispersion) of the channel eigenvalues is referred as *eigenvalue dispersion* (ED), where a higher ED indicates a lower scattering richness in the communication channel, and vice-versa. ED is parameterized by *ellipticity statistic* (ES) [21], [22], as defined by

$$ES = \frac{\left(\prod_{k=1}^K \lambda_k\right)^{\frac{1}{K}}}{\frac{1}{K} \sum_{k=1}^K \lambda_k} \quad (2.19)$$

for a single channel response  $\mathbf{H}$ . The numerator is the geometric mean of the eigenvalues ( $\lambda_k$ 's) of  $\mathbf{H}\mathbf{H}^\dagger$ , whereas the denominator is arithmetic mean of the eigenvalues.  $(\bullet)^\dagger$  is the conjugate transpose operator and  $K$  is the full channel rank of the measured channel, *i.e.*,  $K = \min(M, N)$ .  $ES$  is given as a real scalar value between 0 and 1.  $ES \rightarrow 1$  indicates low ED and thus high channel richness, whereas  $ES \rightarrow 0$  implies correlated sub-channels due to the lack of multi-paths or polarization diversity. The concept of ED gives a more comprehensive representation of the ability of the channel to support parallel subchannels than correlation at one or both link ends, since it also considers possible correlation between TX and RX link ends.

### 2.2.3 MIMO Capacity

Given a set of channel realizations, the capacity performance can be expressed as *ergodic* capacity or *outage* capacity. The ergodic capacity is average capacity over the given channel realizations. On the other hand, an  $x\%$  outage capacity represents the capacity that is guaranteed with  $(100-x)\%$  reliability for the given channel realizations. Since any attempt to transmit packet data at higher capacity than the capacity that the channel can support will lead to an error, the concept of outage capacity can give an indication of packet error rate (PER), when very large packet size and optimal coding are used [11]. Nevertheless, in this thesis, it is the ergodic capacity that is mainly utilized for simplicity reasons.

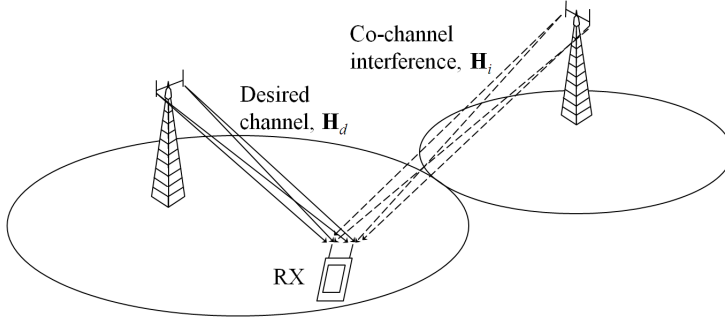

**Figure 2.3:** Desired  $2 \times 2$  MIMO channel and  $2 \times 2$  co-channel interference.

The capacity evaluation is conventionally performed for *noise-limited* (NL) scenarios. However, realistic urban and suburban scenarios, where most of the cellular users are located, are usually *interference-limited* (IL) due to dense cell infrastructures. Therefore, capacity with co-channel interference is also evaluated for selective cases in this thesis. An illustration of co-channel interference in a cellular setting is given in Fig. 2.3.

### Noise-Limited Scenario

MIMO capacity with no channel knowledge at the transmitter, thus assuming the power to be evenly allocated (or equal power) across the TX antennas, is given by [23]:

$$C_{\text{ep}} = \sum_{k=1}^K \log_2 \left( 1 + \frac{SNR \lambda_k}{N} \right), \quad (2.20)$$

where  $K$  is number of orthogonal sub-channels (*i.e.*, rank) and  $\lambda_k$ 's are the eigenvalues of the matrix  $\mathbf{H}\mathbf{H}^\dagger$  (if  $M < N$ ) or  $\mathbf{H}^\dagger\mathbf{H}$  (if  $M > N$ ).  $SNR$  is the mean SNR per received branch. With channel knowledge at the transmitter, MIMO capacity can be obtained with “waterfilling” or “waterpouring”, where power is preferentially allocated to the stronger sub-channels rather than the weaker ones [15]:

$$C_{\text{wf}} = \sum_{k=1}^K \log_2(\lambda_k D) \quad (2.21)$$

and

$$D = \frac{1}{\lambda_k} + p_k \quad (2.22)$$

where  $D$  is the “water level” for each of the sub-channels to be filled up to and  $p_k = SNR_k/\lambda_k$  is the input power to the  $k$ -th sub-channel.

### Interference-Limited Scenario

The channel capacity with interference, when neither the desired channel nor the interference channel is known at the transmitter, is given in [24] as

$$C_{\text{in}} = \log_2(\det(\mathbf{I} + \frac{SNR}{N} \cdot \mathbf{R}^{-1} \mathbf{H}_d \mathbf{H}_d^\dagger)) \quad (2.23)$$

where

$$\mathbf{R} = \frac{INR}{L} \sum_{k=1}^L \mathbf{H}_i \mathbf{H}_i^\dagger + \mathbf{I} \quad (2.24)$$

$\mathbf{H}_d$  is the  $M \times N$  single desired channel matrix response and  $\mathbf{H}_i$  is the matrix response for the  $i$ -th interference source.  $\mathbf{I}$  is  $M \times M$  identity matrix.  $INR$  is the ratio of the total interference power to noise power.  $L$  denotes the number of interferers. The definition assumes spatially colored interference. However, spatially white interference, *i.e.*, interference with high channel richness, is applicable as it can be seen as increase in noise. The co-channel interference is studied in Papers IV and V.

## 2.3 Throughput

In communication systems, throughput is a common network performance parameter. As an end user parameter it is defined as the average rate of successful data transmissions over the overall propagation channel (including the antennas), as experienced by the user of the receiving terminal. In contrast to the context of SISO network performance, throughput has not been a preferred choice as a performance characterization parameter in single-antenna terminal evaluations. However, for multiple-antenna terminal evaluations the interest in it is increasing, especially within the standardization activities of MIMO terminal OTA measurement. International research and standardization frameworks such as 3GPP RAN4 [25], Cellular Telecommunications & Internet Association (CTIA) ERP Workgroup [26] and EU COST Action 2100 Subworking Group 2.2 [27] are currently focusing their efforts on bringing forward fast and cost-effective OTA measurements techniques for MIMO terminals. Throughput has been chosen by these groups to be the candidate parameter for evaluating the overall terminal OTA performance. However, throughput in any communication network is dependent on a number of parameters such as network protocol settings, traffic in the cell, interference, propagation

scenarios and technology platform performance (including antenna configurations and receiver baseband solutions). Due to the large number of variables involved, throughput evaluation of multiple-antenna configurations typically requires certain assumptions and simplifications, if it is to be related to the actual performance of the antenna array under evaluation.

In Paper III, the performance study was performed with throughput as the characterization parameter of the RX multiple antennas in a SIMO communication system. Substantial effort was put into minimizing the number of variables in the test setup, so that the observed throughput differences between the evaluated antenna configurations could be directly related to the antenna system design.

## Chapter 3

# Multiple Antennas in Compact Terminals

In the majority of theoretical studies on SIMO and MIMO systems, the antennas at both TX and RX link ends are typically assumed to be ideal. Specifically, it is often assumed that there is no mutual coupling among the antenna elements, and that the antennas are separated far enough to obtain low correlation - favorable conditions which facilitate high diversity and multiplexing gains. In addition, the ideal antenna elements also have equal gains and high total antenna efficiencies. Moreover, the ideal elements are polarized according to the polarizations of the incoming signals. The radiation patterns of the ideal multiple antennas should also efficiently cover the angular region(s) of the incoming signals and yet maintain orthogonality to one another. In practice, such requirements are to some extent feasible for multiple antennas at the BS end, due to less restriction in implementation space and no user interaction. However, for the user terminal end, these requirements are highly challenging. The potential or ideal performance gain that *can* be practically achieved is heavily conditioned upon the *overall communication channel*, as illustrated in Fig. 3.1. Hence, in contrast to single-antenna implementation, the implementation of multiple antennas in compact terminals should take into consideration the compact design and implementation of the antenna array, together with its interaction with the user and the propagation channel (including the impact of the TX array). These components of the overall communication channel and their challenges are addressed in this chapter.

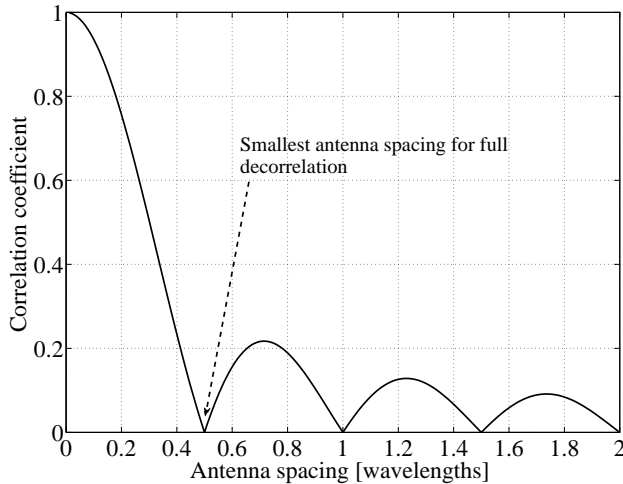

**Figure 3.1:** The overall communication channel comprising multiple-antenna terminal in non-static user and propagation scenario.

### 3.1 Compactness

Today's UEs are both small and lightweight, and they testify of the years of effort and achievement in the development of user terminals, particularly when compared to the bulky and heavy ( $>1$  kg) user terminals of the late 1980's. Yet, in the interest of achieving compact design, new challenges arise, with one of these being the challenge of finding an appropriate antenna separation in the terminal to sufficiently decorrelate incoming signals for multiple-antenna technologies.

Due to their typical usage environments, the UEs commonly experience moderate to large angular spread for the incoming signals. Hence, to enable low enough correlation for spatial diversity, the antenna separation requirement is  $>0.5$  wavelengths (see Fig. 3.2). In Fig. 3.2, the correlation behavior with antenna spacing is plotted for a channel with uniform 3D APS, assuming isotropic antennas. For cellular frequency bands that are lower than 1 GHz, *e.g.*, 700/850/900 MHz, this requirement translates to antenna separations of at least 210 mm. At these frequencies, the terminal length (100-120 mm for a typical smart phone) is less than the required half-wavelength separation. In addition, each of the electrically compact antenna elements tends to excite the entire ground plane structure of the terminal, making the antenna elements *and* the ground plane a common radiation source [28]. This so-called chassis



**Figure 3.2:** Correlation for different antenna separations in uniform 3D APS [11].

wavemode phenomenon greatly increases antenna coupling, due to the different elements sharing the same ground plane for radiation, and this effect further complicates the implementation of compact multiple antennas. The effects of mutual coupling lead to high signal correlation and lower antenna efficiencies, *i.e.*, received power. At higher cellular frequencies, where the terminal is electrically larger, achieving spatial diversity in compact handsets is less challenging, particularly if only a small number of antenna elements are used.

Polarization and angle diversity are alternative methods for achieving high isolation between compact multiple-antenna elements. In a cellular propagation channel, the transmitted wave of a given polarization is commonly depolarized into orthogonal polarizations with uncorrelated fading variations. A multiple-antenna design that employs polarization diversity can be a good solution for compactness, since low correlation can be achieved without antenna separation. However, for the cases where the chassis wavemode is excited at low frequencies, the excitation of two orthogonal chassis polarizations with sufficient bandwidth is hard to achieve [28], [29].

Angle diversity can be exploited by designing the radiation patterns of the multiple-antenna elements to cover different AoAs of the signal. Signals arriving from different directions are typically uncorrelated multi-path components. Since the focus of the design is on angular coverage, the name “angle diversity” is commonly used. It is noted that the term “pattern diversity” is also used

in the literature to represent the same mechanism, although strictly speaking, pattern diversity includes both spatial and angle diversity, with the spatial diversity being introduced by antenna separation.

Spatial, polarization and angle diversity mechanisms may not necessarily be mutually exclusive concepts for internal antennas in compact user terminals. The allocation of volume(s) for antenna implementation may result in antennas with different designs, sizes and placements within the terminal. At high frequencies, spatial, angle and polarization diversity can be simultaneously achieved; however, at low frequencies, standard antenna design techniques originally intended for single-antenna terminals tend to result in angle diversity as the predominant diversity mechanism. Spatial and polarization diversities are limited due to the small terminal size, as previously mentioned. Hence, from the perspective of exploiting multiple diversity mechanisms, the design of multiple antennas at low frequencies poses a significantly more difficult challenge than at high frequencies.

Furthermore, the issue of compactness is not confined to the decrease of terminal size, since it can also be caused by the packing of more hardware inside the same compact shell of the terminal. In particular, user terminals for the existing and upcoming communication systems are expected to operate in several different frequency bands to serve the global wireless market. For example, smart phone antennas today cover at least five frequency bands used by Global System for Mobile Communications (GSM) and Universal Mobile Telecommunications System (UMTS)/HSPA. With the recent deployment of LTE, additional frequency bands are introduced. The number of bands that will be supported by a user terminal depends primarily on transceiver technology development and prospective market infrastructure [3]. However, from the perspective of antenna design, a multi-band antenna occupies a larger volume than a single-band antenna and the efficiency performance is likely to be traded at some frequencies in the attempt to optimize the overall frequency coverage or antenna volume. Fortunately, in the current 3G and 4G standard releases, multiple antennas in UEs are only intended for DL communication. Therefore, only one antenna is required to cover both TX and RX frequencies at a specific band for MIMO operation, whereas the second antenna only needs to cover the RX part of the specific band. In addition to limited antenna efficiencies, the aforesaid trade-offs may cause gain imbalance between multiple antenna branches. Since SIMO and MIMO capacities depend on correlation and power performance of the multiple-antenna system, the challenge is to enhance these performances despite compactness.

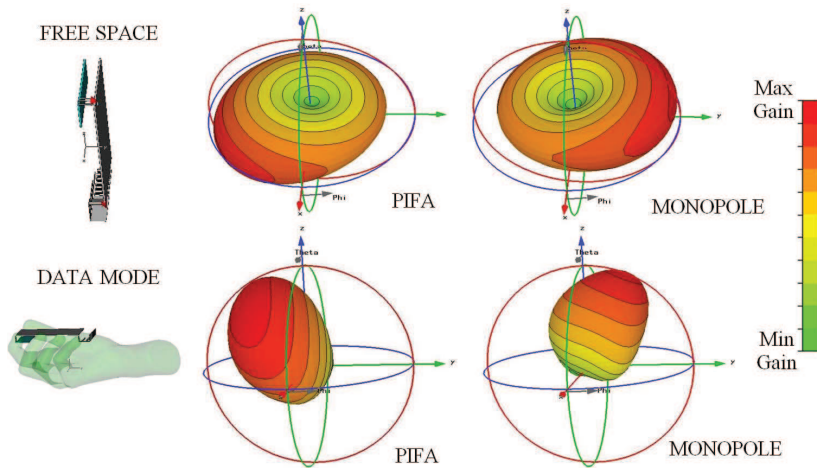

**Figure 3.3:** Radiation pattern distortion of the dual antennas of a compact terminal in the presence of the user hand. [37]

### 3.2 Near Field User Interaction

Regardless of the compact terminal device used, the user is an integral part of the communication channel. Early numerical and experimental studies of the influence of user interaction on single antennas in a mobile handset show that the most severe user effect is the absorption of radiated power, which causes degradation in antenna efficiency and distortion in the effective radiation pattern (see *e.g.*, [30–32] and references therein). Detuning of the antenna is yet another consequence of user interaction. More recent studies confirmed the effects seen on single antennas and further extended the observations on user effects to multiple-antenna figure-of-merits, such as correlation and diversity gain [18], [33–36]. However, these studies are performed mainly on multiple external antennas for mobile handsets in proximity of a user. In this thesis, internal compact antenna arrays are considered and user effects on SIMO and MIMO performance are explored in greater details (see Papers I and II). As an example, one of the user effects observed in the studies is illustrated in Fig. 3.3. The figure shows the differences in radiation patterns of the dual antennas of a compact terminal, when in free space (FS) (*i.e.*, without user) and in proximity of a user, respectively. The consequences of the distortion is discussed in Paper I and II.

The interaction between the user and the UE exists in different forms, depending on the type of UE and the application considered. For example, smart

phones can have versatile applications, and thus several forms of user interactions may be relevant. Today, for single-antenna handsets, the requirements are mainly based on voice application, thus the required test scenario is with the user head present, in the so-called talk position [38]. For packet-oriented communications, it is likely that the testing requirements need to be extended to data transfer scenarios (*e.g.*, file download, browsing and gaming mode). Hence, it is highly relevant to evaluate the performance of terminals with multiple-antenna implementations for high data transfer in handheld scenarios.

At the moment, there is no standard or requirement on test scenarios for terminals involving co-band multiple antennas. Therefore, the studies performed until now, numerical as well as experimental, have used different sizes, shapes and tissue characteristics of the studied user. In this thesis, we have chosen the user head and hand simulation files and their corresponding real-life assemblies from IndexSAR [39]. The phantom head is based on the specifications of the Specific Anthropomorphic Mannequin (SAM) defined in IEEE [40], Comité Européen de Normalisation Électrotechnique (CENELEC) [41] and International Electrotechnical Commission (IEC) [42] standards and standardized for RF power and receiver performance evaluation of single-antenna handsets. Even though the phantom hand is yet to be standardised, the left and right hands used in the thesis were the state-of-art assembly at the time the studies were performed. Both one and two hand grip positions were evaluated in this thesis.

For single-antenna mobile terminals, measurements at both the right and left side of the head are required [12]. While the efficiency performances for both sides are very similar, the MEGs are different [43]. Working with MEG as one of the primary diversity metrics, measurements on both sides of the user head are, thus, to be considered. However, if the APS of the incident fields is uniform in azimuth and elevation, the difference in the MEG performances are the same as the difference in the efficiencies, hence measurements for one side are adequate [43].

### 3.3 Propagation Channel

The transmission medium between the transmitter and receiver, *i.e.*, the propagation channel, makes the transmitted signals undergo a number of propagation phenomena before reaching the RX side. Reflections, diffractions and scattering of the signals are caused by physical objects in the channel, such as buildings, mountains, and moving objects in outdoor environments and walls, furniture, and windows in indoor environments. In a rich reflection, diffraction and scattering environment, the transmitted signal follows a large number of propagation paths en route to the RX end. This condition enables many

copies of the same signal with distinct amplitude, phase, delay, polarization and Doppler characteristics to be received. Assuming the scattering objects to be uniformly distributed around the RX and no direct propagation path between the transmitter and receiver, the scenario is thus non-line-of-sight (NLOS) and the propagation behavior is statistically described by the Rayleigh distribution [1]. Such a NLOS scenario has a large angular spread, which provides a high potential for multiple antennas at the receiver to exploit spatial and angle diversity mechanisms. For multiplexing gain, the NLOS situation is especially important, since it enables full channel rank to be obtained. In the case where there is a direct path between the transmitter and receiver, or LOS, there may be a dominant signal that drowns the independently faded multi-paths, causing a narrow angular spread at the receiver and less potential for exploiting diversity and multiplexing gains. On the other hand, the dominant signal path increases the power in the channel, which increases the SNR [44]. The statistical behavior of a LOS channel is given by the Rice distribution [1]. The dominance of the LOS path in the propagation channel is commonly evaluated with the Rician  $K$ -factor [1]:

$$K = \frac{A^2}{2\sigma^2} \quad (3.1)$$

where  $A^2$  is the power of the dominant component and  $\sigma^2$  is the power of the scattered multi-path components. If  $K \rightarrow 0$  the propagation channel can be characterized with Rayleigh distribution and the assumption of no dominant signal path (*i.e.*, NLOS) would be correct.

The propagation channel is an important part in the evaluation of multiple antennas and their performances. The propagation environment alone sets the underlying conditions or potential for exploiting one or more of different MIMO schemes, including diversity, beamforming and spatial multiplexing. The antenna design and the user interaction further decide the extent to which the potential can be exploited. For example, in dominant LOS cases, the low scattering environment restrains the effective channel rank to be 1, assuming that only spatial diversity is exploited at both the TX and RX ends. However if dual polarization is applied at the TX and RX ends, the rank of 2 can be attained for a  $2 \times 2$  MIMO system, since two orthogonal sub-channels are achieved in polarization. In Paper IV, this observation is confirmed for mobile terminal with polarization diversity in a communication system with dual polarized TX configurations, which are commonly utilized in cellular systems today. However, the extent to which the potential for polarization gain as afforded by the channel is extracted depends on the antenna implementation and the user interaction with the UEs. Hence, the challenge lies in designing multiple antennas with a specific mix of spatial, angle and polarization diversity characteristics in order to exploit the full potential of the channel.

As is standard practice, the noise-limited environment has been frequently used as an example of a realistic environment. However, since the introduction of UMTS communication system and the corresponding wideband code division multiple access (WCDMA) technology, frequency reuse across close-by cells has increasingly become the norm. As a result, the realistic environment has become more interference-limited than noise-limited, particularly for urban cellular deployment. One or more interference sources can be experienced, which have a negative impact on the achievable capacity performance in the cell, see Fig. 2.3. Whereas there are receiver techniques already implemented in mobile terminals to combat interference, the effect of the interference in the context of multiple antennas is a relatively unexplored research topic. It is therefore of interest to gain an understanding on how interference influences the overall communication channel, *i.e.*, how it interacts with the multiple-antenna terminal in different user and propagation scenarios. In Papers IV and V, this subject is studied to obtain some first insights on the radiation and polarization properties of the interference channel and its effects on the MIMO performance of the desired channel.

However, it is common to simplify the propagation environment in order to study specific antenna system issues. This is the case with the studies performed in Papers I and II, where the ideal channel of uniform 3D APS is conveniently chosen, so that the focus is kept on the performance evaluation of a compact multiple-antenna terminal in different user interaction scenarios.

In reality, no two propagation environments are identical if they are not intentionally created. However, on average, some scenarios can be statistically characterized using the same model parameters. For MIMO system level simulations, there are today standardized propagation scenarios provided within the spatial channel model (SCM) in the 3GPPs Release 7 [45], the extension SCME [46] and the Wireless World Initiative New Radio (WINNER) models [47], [48]. Nevertheless, measurements in real environments are still critical to substantiate numerical evaluations and ultimately demonstrate the actual performance of the evaluated antenna system. Furthermore, they are important for the local and instantaneous performances in the scenarios as shown in Papers IV and V. In Papers III, IV, V and VI, the multiple-antenna evaluations were all performed by means of measurements in real propagation channels. The overall communication channels in Papers IV, V and VI are measured with channel sounder and vector network analyzer (VNA) measurement systems. Details on the principles of the utilized measurement techniques can be found in [49], [50].

## Chapter 4

# Enhancement of Multiple-Antenna Performances

As pointed out in the previous chapter, the performance of compact multiple-antenna terminals is strongly influenced by its compactness, its interaction with the user, as well as its interaction with the propagation channel in which the terminal is utilized. The high antenna correlation and severe degradation in radiation performance due to mutual coupling among closely spaced antennas, as well as absorption and antenna detuning due to interaction with the user, call for enhancement techniques that can partly restore the performance potential offered by the propagation channels. If the issue of compactness is considered in isolation, the main goal of the enhancement techniques (commonly referred to as *antenna decoupling techniques*) should be to reduce or to completely eliminate mutual coupling, which indirectly decreases correlation and improves the radiation properties of the antenna systems. However, if the communication channel is considered as a whole, the enhancement techniques need to extend beyond the antenna parameters, to also comprise user interaction and propagation channel. Since the user interaction and the propagation environment are time-varying, particularly in cellular applications, enhancement techniques that enable *channel adaptiveness* are of interest in this thesis.

## 4.1 Antenna Decoupling Techniques

Implementing external circuits after the RX antenna and before the RF components for the purpose of matching the antenna for the maximum power performance is a common and well known approach for single-antenna devices. The optimal matching for single antenna is achieved with conjugate impedance matching of the antenna. The same circuit approach is extended to multiple antennas in form of *multi-port coupled matching*. In this case, multi-port conjugate matching (an extension of the single-port conjugate matching concept) is shown to facilitate optimal power transfer by enabling perfect self-matching and full decoupling across the ports. In addition, the full coupling cancellation also offers zero correlation in an environment with uniform 3D APS [51]. However, in an arbitrary propagation environment, zero correlation does not necessarily facilitate good diversity performance, since it may come at the expense of unequal branch powers. Therefore, the zero correlation case can end up offering the same performance as a case with somewhat higher correlation but having equal branch power [51]. Moreover, it should be noted that multi-port conjugate matching comes with limitations on the bandwidth, which depends on antenna separation. The closer the antennas are spaced, the more narrow-band is the perfectly decoupled solution [52]. Furthermore, there is no generalized approach to the practical realization of multi-port conjugate matching, since most of the existing studies are based on the assumptions of ideal (*i.e.*, lossless) antennas and components.

Additional approach to antenna decoupling is by means of modifying the antenna array structure. Specifically, three techniques have been proposed: modification of ground plane, neutralization line and parasitic scattering [7]. However, these techniques also suffer from narrow bandwidth when the antennas are closely spaced. Furthermore, depending on specific implementations (*e.g.*, placement and available volume for antennas), it may not be feasible to change the antenna or ground plane structures to achieve decoupling.

A more extensive coverage of antenna decoupling techniques for fixed multiple-antenna configurations, which have been briefly presented here, can be found in [7] and the references therein.

## 4.2 Channel Adaptiveness

In order to enable the multiple antennas in compact terminals to be optimized for system level performance in a non-static channel, it is first noted that the antenna structure based techniques for antenna decoupling offer no convenient way of adapting the antenna system to the prevailing channel conditions (which

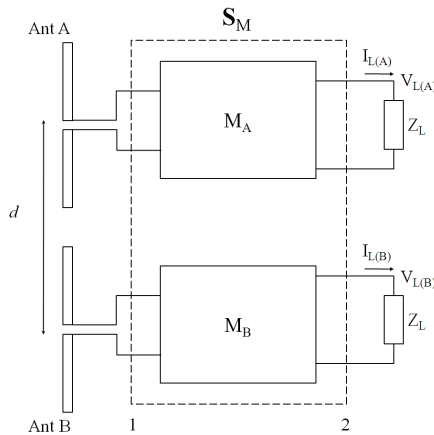

**Figure 4.1:** Uncoupled matching networks ( $M_A$ ,  $M_B$ ) for dual antennas at the RX end, separated by distance  $d$ .

include user interaction and propagation environment). On the other hand, it is relatively straightforward to reconfigure an impedance matching network with tunable circuit elements and components, for the purpose of adapting the antenna system to time-varying channel conditions to achieve better performance. This is particularly the case for uncoupled matching, which employs a separate matching network per antenna (see Fig. 4.1) [53–55].

Uncoupled matching can be performed by means of balanced or unbalanced matching: balanced matching uses identical matching networks for all antennas, whereas unbalanced matching does not require identical matching networks across the antennas. Whereas balanced matching works well for two identical and symmetric antennas in a uniform 3D APS propagation environment, the numerical study in [56] shows that when there are more than two antenna elements and the propagation environment is non-uniform, better adaptation to the propagation environment can be achieved with unbalanced matching. Hence, unbalanced uncoupled matching is preferred for realistic multiple-antenna implementations in an arbitrary propagation environment. A further benefit of unbalanced matching is that, in general, user interaction can cause even two identical and symmetric antennas to behave differently in a uniform environment, *e.g.*, when a hand grip affects one antenna more than the other one. Furthermore, in realistic multiple-antenna implementations, the antennas may not necessarily be of identical design. It is also noted that the antenna design is decisive of the potential of matching in different user and

propagation scenarios, since its radiation and polarization characteristics may not be adaptive enough with matching to suit different characteristics of the communication channel.

The instantaneous  $M \times N$  MIMO channel matrix including uncoupled matching is defined in the full scattering (S-) parameter representation as [57]

$$\mathbf{H}(\mathbf{S}_M) = Z_0^{1/2} \mathbf{S}_{21} (1 - \mathbf{S}_{RR} \mathbf{S}_{11})^{-1} \mathbf{S}_{RT} \quad (4.1)$$

where  $\mathbf{S}_{RR}$  is the  $M \times M$  S-parameter representation of the RX antenna array and  $\mathbf{S}_{RT}$  is the  $M \times N$  channel transfer function between the TX/RX antenna pairs, assuming that there is power transfer in only one direction, and thus no power is coupled back from the RX antenna array to the TX antenna array. The full matching network representation comprises  $M \times M$   $\mathbf{S}_{11}$  and  $\mathbf{S}_{21}$  diagonal matrices, since the matching is uncoupled. Subscripts 1 and 2 refer to input and output ports, respectively (see Fig. 4.1). Both  $\mathbf{S}_{RR}$  and  $\mathbf{S}_{RT}$  can be obtained with a  $(M \times N)$ -port vector network analyzer (VNA), as was the case in Paper VI.

Additional technique for channel adaptiveness is antenna selection, which has been extensively studied in the context of signal processing in [58–60]. Conventionally, the technique implies a large number of ideal antennas from which an optimal subset of the antennas is chosen on the basis of directionality, optimum power or capacity. In compact terminals and for RX purposes, switching between two subsets for maximizing the power is studied in [61], [62]. In papers IV and V in this thesis, switching between antenna topologies for both maximized power and capacity are used to illustrate the benefits of instantaneous channel adaptiveness.

# Chapter 5

## Contributions and Conclusions

This chapter provides a summary for each of the included papers and highlights the main research contributions. It concludes with a discussion on future work.

### 5.1 Research Contributions

#### 5.1.1 PAPER I: “Actual Diversity Performance of a Multi-band Diversity Antenna with Hand and Head Effects”

The inconsistency of correlation behavior and its relation to MEG as well as the consistently high diversity gains for simple, single-frequency, dual-antenna terminals in the proximity of a user in existing literature evoked our interest to better understand the main mechanisms behind the performance of antenna diversity solutions for realistic compact devices. Hence, this study focuses on the diversity performance evaluation of a realistic terminal solution in the proximity of a user. Two internal antennas with multi-band functionality (850/1900/2100 MHz) on a chassis size common to the todays compact mobile phones are evaluated in a reference case of no user interaction (free space) and three user interaction scenarios: handheld (data mode), talk position (*i.e.*, head only position, as is the standard practice for single-antenna terminal evaluations) and talk position with the hand. Extensive simulations and measurements of MEG and correlation were performed assuming a uniform propagation environment, for simplicity reasons. Furthermore, ADG is presented as an appropriate metric

to ascertain the potential of replacing a single antenna with co-band multiple antennas in the mobile handset, and hence it is expected to be of practical interest to antenna engineers in the industry. As a reference, a single multi-band antenna prototype was evaluated in the same user scenarios as the multi-band diversity antenna prototype.

The general decrease of MEGs observed in the presence of a user concurs with previous research. Nevertheless, the absolute values are very much dependent on the antenna design, the type of user interaction and the operating frequency band. The correlation results also demonstrate such dependencies. At the low frequency band, in the case of handheld prototype (data mode), magnitude perturbations in the radiation patterns caused by the presence of the hand is responsible for a decrease in correlation, whereas in other user cases it is the phase behavior of the multiple antennas that is primarily responsible for the overall low correlation. At higher frequencies, the correlation is observed to be almost unaffected by the user.

The ADG performance reveals the realistic gain of replacing a single-antenna solution with a dual-antenna solution in the same user scenario. Specifically, the metric shows higher gains in the handheld case at low frequency as compared to the free space scenario. This is in fact due to the de-correlation of the antenna patterns that results from the presence of the user hand. Moreover, the observed gain depends on the fact that similar body absorption and antenna detuning are experienced by both the single-antenna reference and the diversity prototype. The metric strikes a good balance between DG and EDG, where DG is shown to be an optimistic measure of diversity performance and EDG is the opposite extreme.

I am the main contributor to the paper. I was involved and responsible for all parts of the scientific work: the antenna array design optimization and fabrication, antenna measurements and simulations, data analysis and writing of the paper.

### 5.1.2 PAPER II: “Channel Capacity Performance of Multi-band Dual Antenna in Proximity of a User”

The study in this paper is an extension of the work from a previous research contribution (Paper I). The extension comprises the numerical capacity evaluation of both the reference single-antenna and dual-antenna diversity prototypes in the presence of a user. SISO, SIMO and MIMO ergodic capacities were obtained for two frequency bands (850/2100 MHz) by combining the measured antenna radiation patterns with a channel of 3D uniform APS in simulation. As a reference, a  $2 \times 2$  i.i.d. Rayleigh channel was used.

For different user cases, the behavior of the channel eigenvalues concurs

with the results from the previous study, showing the effects of degradation in capacity due to high correlation and body absorption in the low frequency band and primarily body absorption in the high frequency band. The decrease in MEG in presence of a user causes a decrease in capacity; yet, relative to the single-antenna prototype, the dual-antenna prototype attains significantly higher capacity performance for the same user cases.

I am the main contributor to the paper. I was involved and responsible all parts of the scientific work: numerical analysis and writing of the paper.

### 5.1.3 PAPER III: “Impact of Spacing and Gain Imbalance between Two Dipoles on HSPA Throughput Performance”

The motivation behind the study presented in this paper lies in the conventional rule-of-thumb requirements on equal gain across antenna branches and minimum antenna separation of 0.5 wavelength at the operating frequency for effective signal de-correlation and good spatial diversity gain. In system performance evaluations, the assumption that the antenna arrays at both ends of the link fulfill these requirements is commonly made. In reality, these requirements are hard to achieve in a compact user terminal. Hence, it is of interest to gain knowledge on how the gain imbalance and antenna separation affect the end user experience in practice, that is, if the conventional requirements can be relaxed to a certain extent. For this purpose, a dual dipole configuration with different combinations of gain imbalances and antenna separations is evaluated for throughput at two frequencies (890/1930 MHz) in a repeatable (non-uniform) multi-path environment and in a live HSPA network. A single dipole is also measured as a reference.

It was observed that for the dual dipoles, a gain imbalance of up to 6 dB and an antenna separation of 0.25 wavelengths at both the low and high frequencies are adequate to achieve higher throughput performance than the single dipole at the same transmit power from Node B (*i.e.*, BS). As expected, the performance benefit of the dual-dipole diversity takes effect near the cell edge, when the increased reliability from diversity reception becomes crucial.

I am the main contributor to the paper. I was involved and responsible for all parts of the scientific work: antenna array design, throughput measurements, data analysis and writing of the paper.

#### 5.1.4 PAPER IV: “Experimental Evaluation of MIMO terminal Antenna Configurations in Noise- and Interference-limited Urban Scenarios”

Despite the current deployment of multiple antennas in compact devices for new communications systems such as LTE, today there is still no satisfactory solution to implement these antennas practically or optimally. Moreover, to our knowledge, there is no prior work in investigating the performances of different terminal antenna topologies for the same compact device (with the same ground plane size and outer casing). Therefore, the study presented in this paper focuses on the evaluation of the MIMO performances of three simple dual-antenna topologies that are based on the available space for antenna implementation in a realistic, typical size, smart phone prototype. The goal of the study is to investigate whether antenna system design has the potential to be a key performance differentiator among different terminals. To tie the contribution to realistic cellular communications, extensive  $2 \times 2$  MIMO channel measurements were performed in an urban setting and the performances of the three antenna topologies were analyzed in noise-limited and interference-limited scenarios. Furthermore, the extensive measurement campaign was performed both with and without user interaction at the compact device end; however, this particular contribution focuses specifically on the case of FS, and thus no user is present. A more extensive presentation of the findings, including user interaction, can be found in the next research contribution (see Paper V).

Choosing one of the three antenna topologies over the others for implementation in compact MIMO terminals provides only a modest gain of at most 5% in capacity in FS, when the 50% outage capacity over a 600 m urban route is considered. Nevertheless, the differences in local performances (*i.e.*, for smaller sections of the 600 m route) indicate some potential benefits of antenna reconfigurability to maximize capacity. If switching between configurations for maximum capacity is applied along the entire 600 m route, up to 8% gain can be expected at 50% outage, depending on the choice of the reference (fixed) antenna configuration. Locally, capacity enhancements of up to 16% and 20% for NL and IL cases, respectively, can be obtained when compared to a reference configuration. This gain is higher and dependent on how fast the switching is performed. Note that these antenna topologies are not designed nor optimized for reconfigurability, notwithstanding they are indicative of its potential.

I am the main contributor to the paper. I was involved and responsible for all parts of the scientific work: antenna array design, fabrication and evaluation, channel measurements, data analysis and writing of the paper.

### 5.1.5 PAPER V: “Performance of Handheld MIMO Terminals in Noise- and Interference-limited Urban Macrocellular Scenarios”

Whereas the previous paper gives insights on the performances of three MIMO antenna topologies without user present, as is the standard practice in drive tests (*i.e.*, measurements of devices along pre-defined drive routes), in this paper the contribution is extended to an evaluation of the same prototypes held by hand phantoms in a two-hand user grip position. The chosen hand grip is representative of common grip styles for data communication. The same goal as in the previous paper also applies here, and that is to investigate whether antenna system design has the potential to be a key performance differentiator among different terminals. However, more realistic differentiation in the topologies can be investigated in the present case due to the joint consideration of the antennas, user and propagation environment, *i.e.*, the overall communication channel. Moreover, spatial and cross polarization configurations are also evaluated as reference cases, in order to obtain more insights.

The performances of the reference configurations show the importance of ED for harvesting the potential of MIMO, when the channel gains are equal. In particular, polarization and angle diversity offers significantly lower ED (*i.e.*, higher channel richness), and hence higher capacity, than spatial diversity in both LOS and NLOS noise-limited scenarios. This is because orthogonal channels are achieved in the case of cross polarized antennas whereas the correlation for the  $0.5\lambda$ -separated co-polar dual-dipole set-up is expected to be significantly higher in the presence of one or a few dominant paths.

Contrary to ED being the decisive factor in the capacity performance of the reference antenna configurations, the capacity performance of the handheld terminal configurations largely follows the channel gain. Hence, in general, the best option for enabling maximum capacity in the handheld position is enabled by the topology that offers the best channel gain, sideration of the antennas, user and propagation environment, *i.e.*, the spatial topology. For the 50% outage capacity over the entire route, switching between the three handheld antenna terminal configurations for maximum capacity gives similar performance to that of switching for maximum power.

However, locally along the route, the ED or the channel gain, or a synergy of the two, in both the desired and interference channels, enables different topologies to offer the best performance in different local propagation conditions. Capacity enhancements of up to 17% and 30%, relative to one fixed antenna configuration, are observed by switching for local 20 m route sections in the noise-limited and interference-limited scenarios, respectively. Faster switching (*i.e.*, switching over 1.1 m) is found to offer even greater improvements.

The interference with different power and ED properties along the route causes different effects on the capacity performance. The findings from the evaluation of the reference configurations show that assuming the same signal-to-interference ratio (SIR), spatially white interference in the multi-path rich desired channel can degrade capacity more than the case of spatially colored interference in the low richness desired channel. This is due to the angular spreads of the desired and interference channels. For the case of the desired channel with low richness and the colored interference channel, the angular spread is small and there is a higher probability that the angles of arrival and departure of the multi-path components between the desired and interference channels are misaligned, as compared to the multi-path rich channel with white interference. Hence, whereas rich multi-path channel is of interest when there is no or low interference, less dispersive desired channel can be beneficial when the interference is high and spatially colored.

I am the main contributor to the paper. I was involved and responsible for all parts of the scientific work: antenna array design, fabrication and evaluation, channel measurements, data analysis and writing of the paper.

### 5.1.6 PAPER VI: “On Capacity Maximization of a Hand-held MIMO Terminal with Adaptive Matching in an Indoor Environment”

The final paper included in this thesis goes deeper into the area of capacity enhancement by means of channel adaptiveness. Here, potential MIMO capacity gain from uncoupled adaptive matching, previously unexplored in context of multiple-antenna terminals, is investigated for a compact dual-band MIMO antenna prototype handheld in a two hand grip position. The goal of the study is also to understand the underlying mechanisms.

The capacity performance evaluation is based on  $2 \times 2$  MIMO channel measurements at 0.825 GHz and 2.35 GHz in NLOS and LOS scenarios of an indoor office environment. Ideal, instantaneous adaptive matching, *i.e.*, adaptive matching at each channel realization, is applied in post-processing. The results show that adaptive matching enhances capacity by up to 51% and 22% at the low and high frequency bands, respectively, relative to no matching. The matching states that maximize the capacity at the low frequency is a trade-off between maximum power transfer and maximum channel richness. At the high frequency, the optimal matching states at the high frequency correspond to the conjugate matching of the antenna input impedances, thus only maximum power transfer is enabled. A higher capacity gain is achieved at 0.825 GHz, since the presence of the user affects the dual-antenna terminal performance significantly more at this frequency than in the case of 2.35 GHz, due to the

entire chassis acting as the antenna. Moreover, the antenna performances at 2.35 GHz are much more affected by the absorption in the hands, which results in lower power gain with adaptive matching when compared to the low frequency.

I am the main contributor to the paper. I was involved and responsible for all parts of the scientific work: antenna array design optimization, fabrication and evaluation, channel measurements, performance analysis and writing of the paper.

## 5.2 Conclusions and Future Work

Since ideal requirements of balanced and highly efficient, uncorrelated antenna branches can be unrealistic in the context of multiple-antenna implementation in compact devices, the full potential of spatial sampling may not be achieved. In a real multi-path channel, it was found that even when the power imbalance and antenna separation of the dual-dipoles do not meet the ideal requirements, they may still provide adequate gains in coverage and throughput (Paper III). This indicates that we may be able to relax these requirements in real applications. At the higher cellular frequencies (*i.e.*, approximately 2 GHz and above), this finding is immediately relevant for multiple-antenna implementations in compact user terminals, since the radiations excited by the antenna elements are not strongly bound to the chassis, and thus the chassis does not influence the coupling among the antenna elements significantly. At the lower frequencies (*i.e.*, below 1 GHz), the chassis wavemode excitation brings a further challenge to the implementation of the multiple antennas, as it causes strongly coupled antenna ports and high signal correlation, far above what is expected from only over-the-air coupling. User interaction is shown to partially decouple the antenna ports in the ideal uniform propagation environment. However, due to high radiation absorption, the overall performance is lower than that at higher frequencies (Papers I and II). In real propagation environments, the channels have non-static directional and polarizations properties. In addition, the presence of the user alters the radiations patterns of the antenna array and thus changes the effective angular spread as seen by the antennas. Consequently, optimal interactions between the channel, user and antennas are critical for attaining good capacity performance, which includes proper interference suppression in an interference-limited scenario (Paper V).

It is found that a specific (fixed) multiple-antenna topology may not offer significant performance benefits over another topology, according to the common evaluation approach of considering the statistical performance for a large number of channel realizations, *e.g.*, a long driving route in an urban scenario

(see Papers IV and V). However, in the presence of a user and for instantaneous channels (*e.g.*, over some local sections of the driving route), antenna topology can be a highly significant performance differentiator (Paper V). Hence, a significant potential for performance enhancement is achievable through channel adaptiveness (Paper V). Nevertheless, implementation of different antenna topologies for the purpose of antenna selection to the instantaneous user and propagation scenario in compact devices is at this time impractical and costly. Ideal uncoupled adaptive matching in compact multiple-antenna terminals, on the other hand, shows not only significant capacity enhancements (Paper VI), but it is also considered to be more flexible and practical for implementation as compared to some enhancement techniques based on antenna design and topology selection.

The implementation of multi-port antenna systems in compact user terminals faces a number of significant challenges. Nevertheless, the implementation can be successful if the multiple antennas are designed to exploit all available degrees of freedom in the communication channels. Thus, designs that can optimally exploit the available volume and the effective angular spread (caused by the user and the propagation channel) are necessary in the future to obtain further improvements in the end user experience. Moreover, the challenging problem of body absorption by the user would be interesting and important to address. This is because absorption induces severe power loss in the antenna performance, and therefore there is much to gain from reducing it. To accommodate the non-static properties of the communication channel, adaptive enhancement techniques should also be further explored. Specifically, real, lossy uncoupled matching networks and their impact on the achievable performance gain should be investigated. Moreover, there are still many open issues left to be studied, such as the required speed of adaptation and the design of efficient circuits and adaptive algorithms.

# References

- [1] A. F. Molisch, *Wireless Communications*. New York: Wiley, 2005.
- [2] E. Dahlman, S. Parkvall, J. Sköld, and P. Beming, *3G Evolution: HSPA and LTE for Mobile Broadband*. UK: Academic Press, 2008.
- [3] S. Sesia, I. Toufik, and M. Baker, *LTE-The UMTS Long Term Evolution: From Theory to Practice*. UK: Wiley, 2009.
- [4] <http://www.wimaxforum.org/>.
- [5] D. D. Falconer, F. Adachi, and B. Gudmundsson, “Time division multiple access methods for wireless personal communications,” *IEEE Commun. Mag.*, vol. 33, no. 1, pp. 50–57, 1995.
- [6] J. Fujimoto, *Mobile Antenna Systems Handbook*. US: Artech House, 2000.
- [7] B. K. Lau, “Multiple antenna terminals,” in *MIMO: From Theory to Implementation*, C. Oestges, A. Sibille, and A. Zanella, Eds. San Diego: Academic Press, 2011, ch. 10, pp. 267–298.
- [8] A. de Haas, *Radio-Nieuws*, vol. 10, pp. 357–364, Dec. 1927.
- [9] H. H. Beverage and H. O. Peterson, “Diversity receiving system of RCA communications,” *Proc. IRE*, vol. 19, pp. 531–561, Apr. 1931.
- [10] D. Brennan, “Linear diversity combining techniques,” *Proc. IRE*, vol. 47, no. 6, pp. 1075–1102, Jun. 1959.
- [11] A. Paulraj, R. Nabar, and D. Gore, *Introduction to Space-Time Wireless Communications*. UK: Cambridge University Press, 2003.
- [12] 3GPP TR 25.914, “Technical Specification Group Radio Access Network: Measurements of radio performances for UMTS terminals in speech mode,” V7.0.0, Tech. Rep., Jun. 2006.

- 
- [13] T. Taga, "Analysis for mean effective gain of mobile antennas in land mobile radio environments," *IEEE Trans. Veh. Technol.*, vol. VT-39, no. 2, pp. 117–131, May 1990.
- [14] A. A. Glazunov, A. F. Molisch, and F. Tufvesson, "On the mean effective gain of antennas in a wireless channel," *IET Microw. Antennas Propag.*, vol. 3, no. 2, Mar. 2009.
- [15] R. Vaughan and J. B. Andersen, *Channels, Propagation and Antennas for Mobile Communications*. London, U.K.: Inst. Elect. Eng., 2003.
- [16] M. B. Knudsen and G. F. Pedersen, "Spherical outdoor to indoor power spectrum model at the mobile terminal," *IEEE J. Sel. Areas Commun.*, vol. 20, no. 6, pp. 1156–1168, Aug. 2002.
- [17] M. Schwartz, W. R. Bennett, and S. Stein, *Communication Systems and Techniques*. New York: McGraw-Hill, 1966.
- [18] K. Ogawa and J. Takada, "An analysis of the effective performance of a handset diversity antenna influenced by head, hand and shoulder effects - A proposal for the diversity antenna gain based on a signal bit-error rate and the analytical results for the PDC system," *Electron. Commun. Jpn.*, vol. 84, no. 6, pp. 10–23, 2001.
- [19] P.-S. Kildal and K. Rosengren, "Correlation and capacity of MIMO systems and mutual coupling, radiation efficiency, and diversity gain of their antennas: Simulations and measurements in a reverberation chamber," *IEEE Commun. Mag.*, pp. 104–112, Dec. 2004.
- [20] G. J. Foschini and M. J. Gans, "On limits of wireless communications in a fading environment when using multiple antennas," *Wireless Personal Communications*, vol. 6, pp. 311–335, Mar. 1998.
- [21] J. Salo, P. Suvikunnas, H. M. El-Sallabi, and P. Vainikainen, "Some results on MIMO mutual information: the high SNR case," in *Proc. IEEE Global Telecommuni. Conf (Globecom'2004)*, Dallas, TX, Nov.29-Dec.3, 2004, pp. 943–947.
- [22] —, "Ellipticity statistic as a measure of MIMO multipath richness," *Electron. Lett.*, vol. 42, no. 3, pp. 45–46, Feb. 2006.
- [23] J. Winters, "On the capacity of radio communication systems with diversity in a Rayleigh fading environment," *IEEE J. Select. Areas Commun.*, vol. SAC-5, pp. 871–878, Jun. 1987.

- [24] Y. Song and S. D. Blostein, "MIMO channel capacity in co-channel interference," in *Proc. 21st Biennial Symp. Commun.*, Kingston, Canada, Jan. 2002, pp. 220–224.
- [25] <http://www.3gpp.org/>.
- [26] <http://www.ctia.org/>.
- [27] <http://www.cost2100.org/>.
- [28] P. Vainikainen, J. Ollikainen, O. Kivesäs, and K. Kelander, "Resonator-based analysis of the combination of mobile antenna and chassis," *IEEE Trans. Antennas Propag.*, vol. 50, no. 10, pp. 1433–1444, Oct. 2002.
- [29] D. A. Sánchez-Hernández, *Multiband Integrated Antennas for 4G Terminals*. US: Artech House, 2008.
- [30] J. Toftgård, S. N. Hornsleth, and J. B. Andersen, "Effects on portable antennas of the presence of a person," *IEEE Trans. Antennas Propag.*, vol. AP-41, no. 6, pp. 739–746, Jun. 1993.
- [31] G. F. Pedersen, J. Ø. Nielsen, K. Olesen, and I. Z. Kovacs, "Measured variation in performance of handheld antennas for large number of test persons," in *Proc. 48th Veh. Technol. Conf. (VTC'1998)*, Ottawa, Canada, May 18–21, 1998, pp. 505–509.
- [32] H. R. Chuang, "Human operator coupling effects on radiation characteristics of a portable communication dipole antenna," *IEEE Trans. Antennas Propag.*, vol. 42, no. 4, pp. 556–560, Apr. 1994.
- [33] G. F. Pedersen and S. Skjaeris, "Influence on antenna diversity for a handheld phone by the presence of a person," in *Proc. IEEE 47th Veh. Technol. Conf. (VTC'1997)*, vol. 3, Phoenix, AZ, May 4–7, 1997, pp. 1768–1772.
- [34] B. M. Green and M. A. Jensen, "Diversity performance of dual-antenna handsets near operator tissue," *IEEE Trans. Veh. Technol.*, vol. VT-48, no. 7, pp. 1017–1024, Jul. 2000.
- [35] K. Ogawa, T. Matsuyoshi, and K. Monma, "An analysis of the performance of a handset diversity antenna influenced by head, hand and shoulder effects at 900 MHz - Part I: Effective gain characteristics," *IEEE Trans. Veh. Technol.*, vol. VT-50, no. 3, pp. 830–844, May 2001.

- [36] —, “An analysis of the performance of a handset diversity antenna influenced by head, hand and shoulder effects at 900 MHz - Part II: Correlation characteristics,” *IEEE Trans. Veh. Technol.*, vol. VT-50, no. 3, pp. 845–853, May 2001.
- [37] V. Plicanic, B. K. Lau, and Z. Ying, “Performance of a multiband diversity antenna with hand effects,” in *Proc. IEEE Int. Workshop Antenna Technol. (IWAT’2008)*, Chiba, Japan, Mar. 4-6, 2008, pp. 534–537.
- [38] CTIA Certification, “Test Plan for Mobile Station Over the Air Performance: Method for measurement of the radiated RF power and received performance,” rev. 3.0, Tech. Rep., 2009.
- [39] <http://www.indexsar.com/>.
- [40] IEEE Standard P1528, “Recommended Practice for Determining the Peak Spatial-Average Specific Absorption Rate (SAR) in the Human Head from Wireless Communications Devices: Experimental techniques,” Tech. Rep., Apr. 2003.
- [41] CENELEC Standard ENS 50361, “Basic Standard for the Measurement of Specific Absorption Rate Related to Human Exposure to Electromagnetic Fields from Mobile Phones (300 MHz-3 GHz),” Brussels, Belgium, CENELEC, Tech. Rep., Jul. 2001.
- [42] IEC Standard 106 PT62209 part 1 Ed. 1.0, “Procedure to Measure the Specific Absorption Rate (SAR) in the Frequency Range of 300 MHz to 3 GHz - Part 1: Hand-held mobile wireless communication devices,” part 1, Ed. 1.0, Tech. Rep., 2005.
- [43] J. Krogerus, C. Icheln, and P. Vainikainen, “Dependence of mean effective gain of mobile terminal antennas on side of head,” in *Proc. Europ. Conf. on Wireless Technol.*, Paris, France, Oct.3-4 2005, pp. 467–470.
- [44] J. B. Andersen, “Propagation aspects of MIMO channel modelling,” in *Space Time Wireless Systems: From Array Processing to MIMO Communication*, H. Bölcskei, D. Gesbert, C. Papadias, and A. J. van der Veen, Eds. UK: Cambridge University Press, 2006, pp. 3–22.
- [45] 3GPP TR 25.996, “Technical Specification Group Radio Access Network: Spatial channel model for multiple input multiple output (MIMO) simulations,” V7.0.0, Tech. Rep., Jun. 2007.

- 
- [46] D. S. Baum, J. Salo, G. D. Galdo, M. Milojevic, P. Kyösti, and J. Hansen, "An interim channel model for beyond-3G systems: extending the 3GPP spatial channel model (SCM)," in *Proc. IEEE Veh. Technol. Conf. (VTC'05-Spring)*, Stockholm, Sweden, May 30-Jun. 1, 2005.
- [47] IST-2003-507581 WINNER D1.1.2, "Final report on link and system level channel models," D5.4 v. 1.4, Tech. Rep., Nov. 2005.
- [48] IST-4-027756 WINNER II, "WINNER II Channel Models," D1.1.2 V1.1, Tech. Rep., Sept. 2007.
- [49] E. Thoma, D. Hampicke, A. Richter, G. Sommerkorn, A. Schneider, U. Trautwein, and W. Wirnitzer, "Identification of time-variant directional mobile radio channels," *IEEE Trans. Instrum. Meas.*, vol. 49, no. 2, pp. 357–364, April 2000.
- [50] J. Kåredal, "Measurement-based modelling of wireless propagation channels - MIMO and UWB," Ph.D. dissertation, Lund University, 2009.
- [51] J. W. Wallace and M. A. Jensen, "Termination-dependant diversity performance of coupled antennas: Network theory analysis," *IEEE Trans. Antennas Propag.*, vol. 52, no. 1, pp. 98–105, Jan. 2004.
- [52] B. K. Lau, J. B. Andersen, G. Kristensson, and A. F. Molisch, "Impact of antenna matching network on bandwidth of compact antenna arrays," *IEEE Trans. Antennas Propag.*, vol. 54, no. 11, pp. 3225–3238, Nov. 2006.
- [53] B. K. Lau and J. B. Andersen, "On closely coupled dipoles with load matching in a random field," in *Proc. IEEE 17th Int. Symp. Personal, Indoor and Mobile Radio Commun. (PIMRC'2006)*, Helsinki, Finland, Sep. 11-14, 2006.
- [54] Y. Fei, B. K. Lau, A. Sunesson, A. J. Johansson, J. B. Andersen, and J. Thompson, "Experiments of closely coupled monopoles with load matching in a random field," in *Proc. 1st Europ. Conf. Antennas Propag. (EuCAP'2006)*, Nice, France, Nov. 6-10, 2006.
- [55] Y. Fei, Y. Fan, B. K. Lau, and J. S. Thompson, "Optimal single port matching impedance for capacity maximization in compact MIMO arrays," *IEEE Trans. Antennas Propagat.*, vol. 56, no. 11, pp. 3566–3575, Nov. 2008.
- [56] R. Tian and B. K. Lau, "Uncoupled antenna matching for performance optimization in compact MIMO systems using unbalanced load impedance,"

- in *Proc. 67th IEEE Veh. Technol. Conf. (VTC'2008)*, Singapore, 2008, pp. 299–303.
- [57] J. W. Wallace and M. A. Jensen, “Mutual coupling in MIMO wireless systems: A rigorous network theory analysis,” *IEEE Trans. Wireless Commun.*, vol. 3, no. 4, pp. 1317–1325, Jul. 2004.
- [58] D. A. Gore and A. J. Paulraj, “MIMO antenna selection with space-time coding,” *IEEE Trans. Signal Process.*, vol. 50, no. 10, pp. 2580–2588, Oct. 2002.
- [59] A. F. Molisch, M. Z. Win, Y.-S. Choi, and J. H. Winters, “Capacity of MIMO systems with antenna selection,” *IEEE Trans. Wireless Commun.*, vol. 4, no. 4, pp. 1759–1772, Jul. 2005.
- [60] M. A. Jensen and M. L. Morris, “Efficient capacity-based antenna selection for MIMO systems,” *IEEE Trans. Veh. Technol.*, vol. 54, no. 1, pp. 110–116, Jan. 2005.
- [61] F. Harrysson, A. Derneryd, and F. Tufvesson, “Evaluation of user hand and body impact on multiple antenna handset performance,” in *Proc. IEEE Int. Symp. Antennas Propagat.*, Toronto, Canada, Jul. 11–17, 2010.
- [62] R. Valkonen, S. Myllymaki, A. Huttunen, J. Holopainen, J. Ilvonen, P. Vainikainen, and H. Jantunen, “Compensation of finger effect on mobile terminals antenna by antenna selection,” in *Proc. Int. Conf. Electromagn. Adv. Appl. (ICEAA'2010)*, Sydney, Australia, Sept. 20–25, 2010.