



LUND UNIVERSITY

Experimental and Theoretical-studies of the 4s2 N P 2p Sequence In Neutral Gallium

Jonsson, G; Levinson, C; Lindgren, I; Persson, Anders; Wahlström, Claes-Göran

Published in:

Zeitschrift für Physik A Hadrons and Nuclei

DOI:

[10.1007/BF01412069](https://doi.org/10.1007/BF01412069)

1985

[Link to publication](#)

Citation for published version (APA):

Jonsson, G., Levinson, C., Lindgren, I., Persson, A., & Wahlström, C.-G. (1985). Experimental and Theoretical-studies of the 4s2 N P 2p Sequence In Neutral Gallium. *Zeitschrift für Physik A Hadrons and Nuclei*, 322(3), 351-356. <https://doi.org/10.1007/BF01412069>

Total number of authors:

5

General rights

Unless other specific re-use rights are stated the following general rights apply:

Copyright and moral rights for the publications made accessible in the public portal are retained by the authors and/or other copyright owners and it is a condition of accessing publications that users recognise and abide by the legal requirements associated with these rights.

- Users may download and print one copy of any publication from the public portal for the purpose of private study or research.
- You may not further distribute the material or use it for any profit-making activity or commercial gain
- You may freely distribute the URL identifying the publication in the public portal

Read more about Creative commons licenses: <https://creativecommons.org/licenses/>

Take down policy

If you believe that this document breaches copyright please contact us providing details, and we will remove access to the work immediately and investigate your claim.

LUND UNIVERSITY

PO Box 117
221 00 Lund
+46 46-222 00 00

Experimental and Theoretical Studies of the $4s^2 np^2P$ Sequence in Neutral Gallium

G. Jönsson, C. Levinson, I. Lindgren*, A. Persson, and C.G. Wahlström

Department of Physics, Lund Institute of Technology, Lund, Sweden

* Department of Physics, Chalmers University of Technology, Göteborg, Sweden

Received July 1, 1985

Using time-resolved laser spectroscopy lifetime values as well as hyperfine coupling constants have been determined for the $4s^2 np^2P_{3/2}$ ($n=7-11$) states in ^{69}Ga and ^{71}Ga . Theoretical calculations of hyperfine structures based on many-body perturbation theory have been performed in the same sequence ($n=4-8$) for both fine-structure components. The theoretical values are compared with existing experimental data.

PACS: 31.30. Gs; 32.70. Fw; 35.10. Fk

Introduction

During recent years, groups in Lund and Amsterdam have been studying the group IIIA elements Al, Ga and In, using laser spectroscopy techniques. A large number of lifetime values have been determined using time-resolved techniques [1-3]. High resolution techniques employing cw lasers have been used to determine hyperfine structures (hfs) and isotope shifts in lower-lying states [4-6]. With the quantum beat method small hfs splittings in higher-lying states have also been determined [7-9]. Calculations using many-body perturbation theory (MBPT) [10] have given values for the magnetic dipole constant of low-lying states [11]. However, since correlation effects were not included in these calculations large deviations from experimental data were found. In this paper we present new experimental data concerning lifetimes and hfs in the $4s^2 np^2P$ sequence ($n=7-11$, $J=3/2$) in gallium. Extended MBPT calculations for both fine-structure components in this sequence ($n=4-8$) have been performed, including core polarization, correlation and relativistic effects.

Experimental Arrangements

The experimental set-up is shown in Fig. 1. Two dye lasers pumped by an excimer laser (Lambda Physik

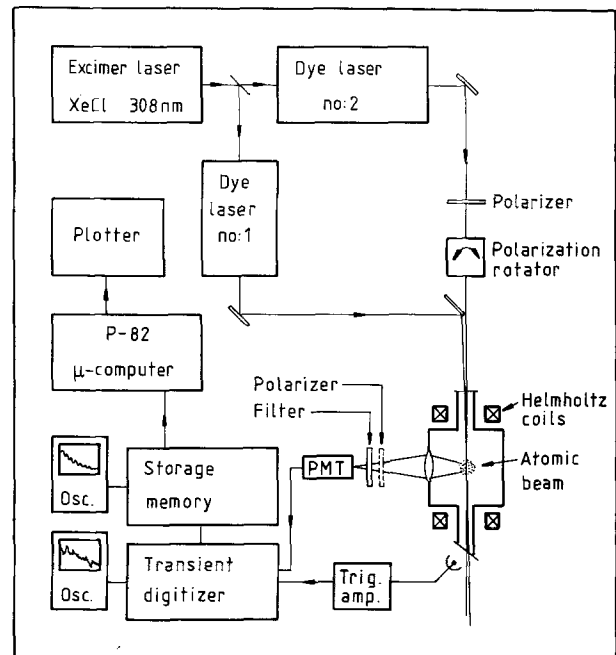

Fig. 1. Experimental set-up for lifetime and quantum beat measurements on $^{69,71}\text{Ga}$

EMG 102E with XeCl gas) were used for step-wise excitation. A home-built Littman cavity dye laser, operating on Stilbene 1, was used to populate the $4s^2 5s^2 S_{1/2}$ intermediate level (417.2 nm). About 90% of the excimer light was used to pump the second step laser (Lambda Physik FL 2002) which was

operated on Coumarin 47 or Coumarin 307 dye. The two dye laser beams were temporally and spatially overlapped in an atomic beam of gallium. The polarization angle of the second step laser could be set with a polarization rotator. The magnetic field in the excitation region was controlled by Helmholtz coils. The fluorescence light from an excited state passed through appropriate filters and was imaged on a fast photomultiplier tube (EMI 9816 QB). During the quantum beat measurements a plane polarizer was inserted on the detection side. Signals coming from the photomultiplier tube were captured by a transient recorder (Biomation 8100) and added in a storage memory. Typically 1,000 transients were collected before a recording was transferred to a P-82 microcomputer for evaluation.

Measurements and Results

A schematic energy level diagram is shown in Fig. 2. The wavelength settings of the second-step laser could be found in the literature [12] except for the $4s^2 8p^2 P_{1/2, 3/2}$ states. The air wavelengths for these states were 493.95(5) and 493.71(5) nm, respectively, when taken from the dye laser setting.

The lifetime measurements were performed on a low-density atomic beam in order to avoid multiple scattering and nonradiative decay via collisions. A fairly large magnetic field (~ 5 mT) eliminated distortion of the decay curves due to slow Zeeman quantum beats. The lifetime values of both $4s^2 np^2 P_{1/2, 3/2}$ fine-structure components were measured separately but no significant difference was found. In Table 1 lifetime values of the doublets are given. Lifetime values in a hydrogen-like sequence are expected to follow a $(n^*)^3$ dependence, where n^* is the effective principal quantum number. In this case we found

$$\tau = 6.0 \cdot (n^*)^{2.67}; \quad (n = 7-11).$$

However, it should be noted that long-lived states are vulnerable to transitions induced by black-body radiation [13, 14] and that the stated values refer to room temperature.

During the quantum beat measurements of the hyperfine structure the Earth's magnetic field was compensated for. The current through the compensating coils was determined using Zeeman quantum beats in the $6s6p^3P_1 - 6s^21S_0$ transition in ytterbium. The two isotopes of gallium, ^{69}Ga and ^{71}Ga , have natural abundances of 60% and 40%, respectively, and both have a nuclear spin of $I = 3/2$. With right-angle geometry (between the atomic beam, excitation and

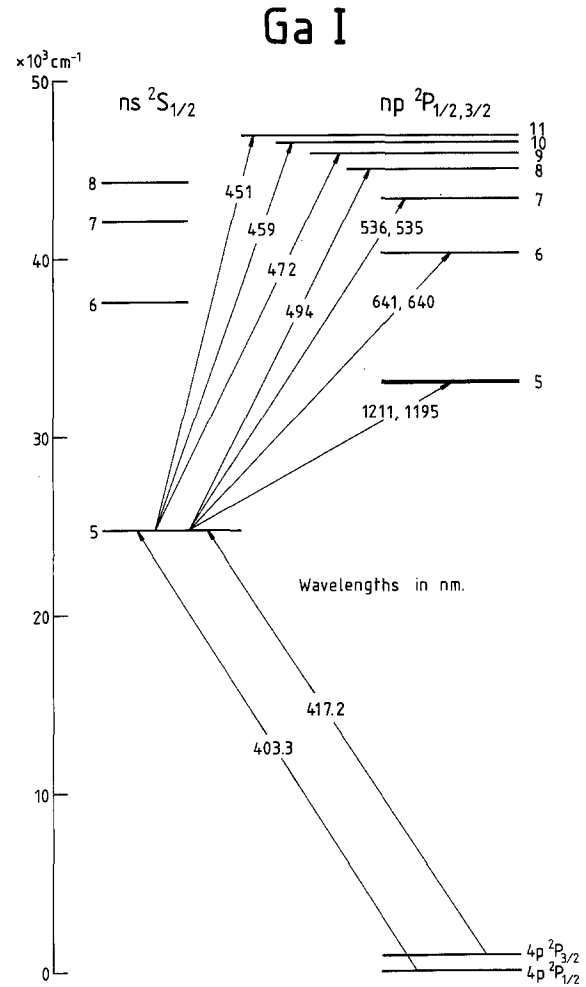

Fig. 2. Energy level diagram of neutral gallium

Table 1. Observed lifetimes

n	Lifetimes (ns)
7	380 ± 20
8	660 ± 40
9	920 ± 60
10	$1,450 \pm 100$
11	$2,000 \pm 200$

detection), only the $J = 3/2$ fine structure component in the $4s^2 np^2 P$ sequence will cause beats [15]. The selection rules for hyperfine quantum beats are $\Delta F = 1, 2$. If the splittings in the $4s^2 np^2 P_{3/2}$ states are expressed in terms of the magnetic dipole constant, A , and the electric quadrupole constant, B , two sets of beat frequencies corresponding to $5A$, $3A + B$, $3A - 2B$, $2A - B$ and $A - B$ are possible. A maximum beat amplitude is obtained when the polarizers for the excitation and detection light are parallel. In order to find as many as possible of the ten beat frequencies the following procedure was used. To

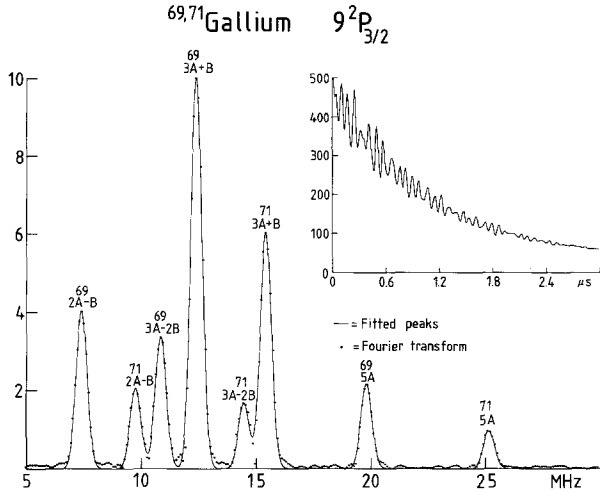

Fig. 3. Fluorescence decay and Fourier transform of the $9^2P_{3/2}$ state. The intensities on the vertical axes are given in arbitrary units

each recorded curve an exponential function, on a background, was fitted. The experimental curve was then divided by the exponential leaving an undamped beat structure. The divided curve was centred around zero and multiplied by an apodization function. Since the time spectrum is cut off, the peaks in the Fourier transformed spectrum will always have side-lobes. An apodization function can suppress these extra peaks at the price of somewhat broader lines. A number of apodization functions [16] were tested and a so-called Hamming window was used in our evaluation. The apodized curve was transformed into the frequency domain using a Fast Fourier Transform [16]. The peak positions were calculated from the amplitude spectrum by repeatedly fitting a gaussian curve to the highest peak and subtracting it from the spectrum. In this way we could determine eight of the ten possible lines. The intensity of the two $A-B$ peaks was too weak for the peaks to be identified. Figure 3 shows an experimental curve and the corresponding frequency spectrum. From the peak positions values of A and B were calculated using a multiple regression analysis program. The experimental A and B constants are given in Table 2. The experimental data for $n=7-11$ have a behaviour very close to an $(n^*)^{-3}$ dependence

$$\begin{aligned} A_{3/2}(69) &= 1,036.3 \cdot (n^*)^{-2.921} \text{ MHz} \\ A_{3/2}(71) &= 1,328.6 \cdot (n^*)^{-2.926} \text{ MHz} \\ B_{3/2}(69) &= 180.4 \cdot (n^*)^{-3.076} \text{ MHz} \\ B_{3/2}(71) &= 111.5 \cdot (n^*)^{-3.075} \text{ MHz}. \end{aligned}$$

This yields $\frac{\mu_{71}}{\mu_{69}} = 1.282$ and $\frac{Q_{71}}{Q_{69}} = 0.618$ which is in good agreement with $\frac{\mu_{71}}{\mu_{69}} = 1.270$ and $\frac{Q_{71}}{Q_{69}} = 0.629$ [17].

Table 2. Measured hyperfine constants

n	A (MHz)	B (MHz)
^{69}Ga		
7	11.13 ± 0.02	1.52 ± 0.03
8	6.35 ± 0.02	0.85 ± 0.01
9	3.96 ± 0.01	0.51 ± 0.02
10	2.64 ± 0.01	0.34 ± 0.01
11	1.84 ± 0.01	0.22 ± 0.02
^{71}Ga		
7	14.12 ± 0.03	0.95 ± 0.05
8	8.07 ± 0.02	0.52 ± 0.02
9	5.03 ± 0.01	0.31 ± 0.01
10	3.35 ± 0.01	0.21 ± 0.01
11	2.33 ± 0.01	0.13 ± 0.02

Theoretical Calculation of the Hyperfine Structure Using Many-Body Perturbation Theory

For the analysis of experimental hyperfine data as well as for the ab-initio evaluation of the hyperfine interaction (hfi) it is convenient to use the effective-operator formalism [18]. For an atomic system with an np configuration (outside closed shells) the magnetic dipole and electric quadrupole interaction constants can then be expressed

$$A(^2P_{1/2}) = C \cdot g_I \cdot \left\{ \frac{4}{3} \langle r^{-3} \rangle_{01} + \frac{4}{3} \langle r^{-3} \rangle_{12} - \frac{1}{3} \langle r^{-3} \rangle_{10} \right\} \quad (1a)$$

$$A(^2P_{3/2}) = C \cdot g_I \cdot \left\{ \frac{2}{3} \langle r^{-3} \rangle_{01} - \frac{2}{15} \langle r^{-3} \rangle_{12} + \frac{1}{3} \langle r^{-3} \rangle_{10} \right\} \quad (1b)$$

$$B(^2P_{1/2}) \equiv 0$$

$$B(^2P_{3/2}) = D \cdot Q \cdot \frac{2}{5} \cdot \langle r^{-3} \rangle_{02}.$$

Here, the parameters $\langle r^{-3} \rangle_{ij}$ correspond to the effective hyperfine parameters of rank i, j in spin and orbital space respectively (01 = orbital, 12 = spin-dipole, 10 = contact and 02 = quadrupole). g_I is the nuclear magnetic g factor and Q is the quadrupole moment of the nucleus. If the hyperfine constants are measured in MHz and the nuclear moments in nuclear magnetons (n.m.) and barns, then the constants C and D have the following values for ^{69}Ga

$$C = 95.40943 \text{ MHz/n.m.}$$

$$D = 234.9730 \text{ MHz/barn}$$

using the values $\mu_{69} = +2.011 \text{ n.m.}$ and $Q_{69} = 0.178 \text{ barns}$ [17].

The effective hyperfine parameters can be given a well-defined interpretation by means of many-body perturbation theory (MBPT), and a particularly simple representation when the diagrammatic form of

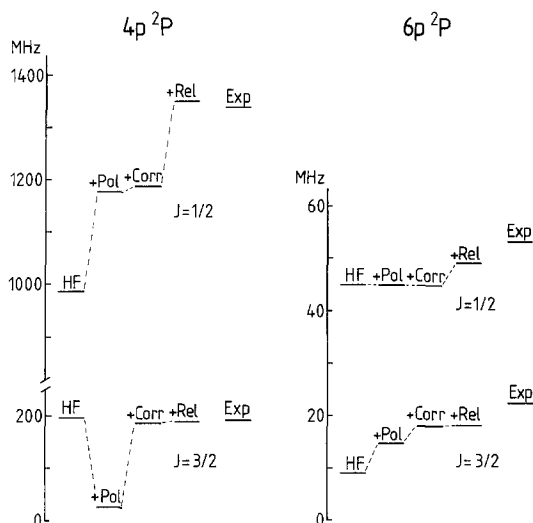

Fig. 4. Different contributions to the theoretical dipole-coupling constants. Illustrated by two of the investigated 2P states

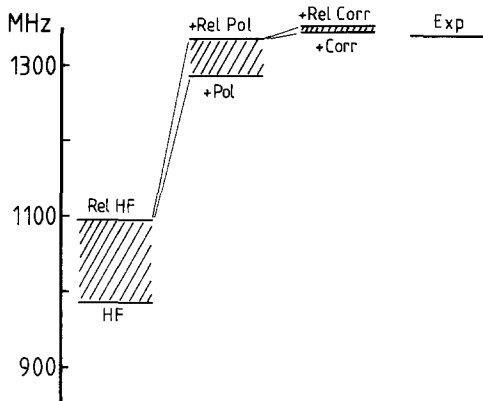

Fig. 5. Illustration of how relativistic effects add to the different contributions. Shown for the magnetic dipole-coupling constant for the $4p\ ^2P_{1/2}$ ground state

this theory is used. In the present work we have used the form of MBPT developed, in particular, by the Chalmers group [10] to evaluate the hyperfine interaction for the $4s^2np$ states of gallium with $n = 4-8$. This procedure, which is based upon the numerical solution of inhomogeneous one- and two-particle equations, has been described in detail in the literature, and therefore we restrict ourselves here to a brief description of its main features.

The starting point for our calculations is with the non-relativistic Hartree-Fock (HF) functions, generated in the electron core of the singly ionized system (with the np electron removed), which we refer to as “HF $^{-1}$ ”. The remaining interaction, i.e. the electron-electron interaction not included in HF $^{-1}$ and the hyperfine interaction, is then treated by means of perturbation theory. (For the moment we disregard

spin-orbit coupling and other relativistic effects.) The effect of the perturbation is to mix other (virtually excited) HF states with the HF state under consideration. These effects can be separated into one-, two-, ... body types, depending on the maximum number of electrons involved simultaneously in the “excitation”. The one-body (single-particle) effects correspond to polarization of the core due to the interaction with the valence electron, and the polarized core interacts with the nucleus, leading to a hyperfine contribution. (Alternatively, the same effect can be regarded as a polarization, due to the nuclear moments, which interacts with the valence electron.) For core s electrons this effect is the important spin polarization, which leads to an induced contact interaction, also for non- s valence electrons ($\langle r^{-3} \rangle_{10}$ in (1)). Non- s electrons of the core also contribute to the polarization and affect the magnetic dipole as well as the electric quadrupole interaction – the latter effect usually being referred to as the Sternheimer effect [19].

In the present work the polarization effect is evaluated to all orders of perturbation theory by solving a set of inhomogeneous single-particle equations iteratively – a procedure which is essentially equivalent to unrestricted Hartree-Fock [20].

Two-particle- or pair-correlation effects can similarly be evaluated by solving inhomogeneous two-particle (pair) equations [21]. In the present work the pair functions are evaluated to first order, and by combining first-order single-particle and pair functions all third-order hyperfine effects can be evaluated. Since all-order single-particle functions are used in the present work, important higher-order effects are automatically included in this procedure [22].

The pair correlation can also lead to single-particle effects in higher orders, which can be regarded as a modification of the HF orbitals towards Brueckner orbitals (BO) [22]. Such modifications of the occupied orbitals are evaluated in the present work by means of the first-order pair functions. The new orbitals are then used to re-evaluate the core polarization and the “third-order” diagrams. Using this procedure it is expected that the most important fourth-order effects are included.

The gallium atom is a relatively heavy atom and it is obvious that relativistic effects cannot be neglected in an accurate calculation. No fully relativistic MBPT procedure is yet available and therefore we have applied the following approximate scheme.

The non-relativistic Hartree-Fock, polarization and correlation effects are first evaluated as described above. Then relativistic Hartree-Fock [23] and single-particle [24] programs are used to evaluate the relativistic effects on the HF and the polarization

levels. From these calculations, a “relativistic correction” for the correlation effect is finally estimated and included.

The numerical results obtained in the present work are given in Tables 3–5 and will be further discussed below.

The procedure employed here is quite easy to use, and represents a suitable compromise between accuracy and convenience. The procedure is also designed to include pair-correlation effects to higher orders [25], and it has been applied in this form to hyperfine calculations on some lighter atoms [26]. Such a procedure, however, requires considerably more computer power as well as manpower, and is motivated only when high accuracy is required.

Discussion

From the effective parameters compiled in Table 3 several interesting observations can be made. In the $4p$ state there is a large *negative* spin polarization, while for the higher states this contribution is positive (and decreases with decreasing n). This is evidently due to the large overlap between the $4p$ and $4s$ orbitals, causing a particularly large spin polarization of the $4s$ shell in the ground state. For the same reason there is a particularly large correlation effect in the ground state; this is reduced by one order of magnitude in going from $4p$ to $5p$. In addition, it can be found – as in other similar calculations – that a large fraction ($\sim 80\%$) of the correlation effect, relative to HF, is included in the Brueckner orbitals.

From the comparison between the theoretical and experimental results in Table 4 it is found that the agreement is very good for the ground state but less so for the excited states. Due to the large overlap between the $4p$ and $4s$ orbitals and the large correlation effects in the ground state one would expect a comparatively slow convergence in that state and therefore less accurate results using first-order pair functions. For the excited states, on the other hand, there is reason to believe that such an approximation should be quite adequate. However, the results in Table 4 do not seem to verify these assumptions. The very good agreement obtained for the ground state is probably partly fortuitous. The lack of agreement for the excited states, on the other hand, is more difficult to understand. The relatively small contributions due to the correlation (including the Brueckner-orbital contribution) indicate that the results would not be substantially improved by iterating the pair functions and thereby including pair correlation to higher orders.

Table 3. Theoretical effective hyperfine parameters for ^{69}Ga (in atomic units)

	$\langle r^{-3} \rangle_{01}$	$\langle r^{-3} \rangle_{12}$	$\langle r^{-3} \rangle_{10}$	$\langle r^{-3} \rangle_{02}$
4p				
HF ⁻¹	2.67500	2.67500	0.00000	2.67500
Polarization (HF)	0.20301	0.36505	-3.93925	0.72970
Brueckner orbitals	0.47912	0.47912	0.00000	0.47912
Polarization (BO)	0.02527	0.04087	0.38751	0.07770
Correlation (BO)	-0.08278	-0.09866	2.70912	-0.16447
Total	3.29962	3.46138	-0.84262	3.79706
5p				
HF ⁻¹	0.34740	0.34740	0.00000	0.34740
Polarization (HF)	0.02925	0.04481	0.24890	0.08517
Brueckner orbitals	0.03070	0.03070	0.00000	0.03070
Polarization (BO)	0.01889	0.00114	0.14199	0.00076
Correlation (BO)	-0.00074	-0.00645	0.08346	-0.00200
Total	0.42550	0.41759	0.47435	0.46202
6p				
HF ⁻¹	0.13179	0.13179	0.00000	0.13179
Polarization (HF)	0.01132	0.01688	0.11862	0.03135
Brueckner orbitals	0.00815	0.00815	0.00000	0.00815
Polarization (BO)	0.00050	0.00007	0.04081	-0.00053
Correlation (BO)	0.00004	-0.00262	0.02171	-0.00051
Total	0.15181	0.15428	0.18115	0.17026
7p				
HF ⁻¹	0.06442	0.06442	0.00000	0.06442
Polarization (HF)	0.00558	0.00823	0.06181	0.01513
Brueckner orbitals	0.00334	0.00334	0.00000	0.00334
Polarization (BO)	0.00019	-0.00005	0.01806	-0.00043
Correlation (BO)	0.00031	-0.00111	0.00927	0.00004
Total	0.07384	0.07484	0.08914	0.08251
8p				
HF ⁻¹	0.03626	0.03626	0.00000	0.03626
Polarization (HF)	0.00368	0.00462	0.03578	0.04472
Brueckner orbitals	0.00167	0.00167	0.00000	0.00167
Polarization (BO)	-0.00044	-0.00004	0.00916	-0.03655
Correlation (BO)	0.00022	-0.00099	0.00502	0.00008
Total	0.04139	0.04152	0.04996	0.04617

Similar calculations to those performed here are presently under way for the Al sequence [27]. Here also, higher-order pair correlation effects are included for the ground state as well as for the excited states, and these results may also shed some light on the Ga results presented here. In any case, more advanced calculations on the Ga sequence will not be performed until the Al results have been properly analysed.

Table 4. Hyperfine coupling constants for ^{69}Ga in MHz. (The theoretical B -factors were calculated using the quadrupole moment $Q_{69}=0.178$ barns [17])

	$A_{1/2}$	$A_{3/2}$	$B_{3/2}$
4p			
HF $^{-1}$	912.3	182.5	44.8
Core polarization	264.8	-156.9	15.2
Correlation	11.8	161.0	3.5
Relativistic effects	162.8	2.0	-2.4
Total	1,351.7	188.6	61.1
Experimental [28]	1,338.994	190.794	62.522
5p			
HF $^{-1}$	118.5	23.7	5.8
Core polarization	2.0	12.3	1.4
Correlation	3.1	13.4	0.5
Relativistic effects	15.1	-1.2	0.3
Total	138.7	48.2	8.0
Experimental	-	-	-
6p			
HF $^{-1}$	44.9	9.0	2.2
Core polarization	-0.1	5.7	0.5
Correlation	-0.3	3.3	0.1
Relativistic effects	4.8	0.2	0.1
Total	49.3	18.2	2.9
Experimental [4]	53.3(7)	22.4(2)	3.2(3)
7p			
HF $^{-1}$	22.0	4.4	1.1
Core polarization	-0.3	3.0	0.2
Correlation	-0.2	1.4	0.1
Relativistic effects	2.3	0.1	0.0
Total	23.8	8.9	1.4
Experimental (this work)	-	11.13(2)	1.52(3)
8p			
HF $^{-1}$	12.4	2.5	0.6
Core polarization	-0.2	1.7	0.2
Correlation	-0.2	0.8	0.0
Relativistic effects	1.3	0.1	0.0
Total	13.3	5.1	0.8
Experimental (this work)	-	6.35(2)	0.85(1)

Table 5. The effect of grid extrapolation [21] illustrated by the nonrelativistic calculations for the ground state

Points in grid	$A_{1/2}$	$A_{3/2}$	$B_{3/2}$
41	1,195.5	211.5	64.7
51	1,192.7	202.2	64.3
61	1,191.4	197.3	64.1
Extrapolated	1,188.9	186.6	63.5

References

- Jönsson, G., Lundberg, H., Svanberg, S.: Phys. Rev. A **27**, 2930 (1983)
- Jönsson, G., Lundberg, H.: Z. Phys. A - Atoms and Nuclei **313**, 151 (1983)
- Zaki Ewiss, M.A., Snoek, C.: J. Phys. B **16**, L153 (1983)
- Jönsson, G., Levinson, C., Svanberg, S., Wahlström, C.-G.: Phys. Lett. **93A**, 121 (1983)
- Jiang Zhan-Kui, Lundberg, H., Svanberg, S.: Phys. Lett. **92A**, 27 (1982)
- Jiang Zhan-Kui, Lundberg, H., Svanberg, S.: Z. Phys. A - Atoms and Nuclei **306**, 7 (1982)
- Jönsson, G., Kröll, S., Lundberg, H., Svanberg, S.: Z. Phys. A - Atoms and Nuclei **316**, 259 (1984)
- Neijzen, J.H.M., Dönszelmann, A.: Physica **98C**, 143 (1979)
- Neijzen, J.H.M., Dönszelmann, A.: Physica **114C**, 395 (1982)
- Lindgren, I., Morrison, I.: Atomic many-body theory. In: Springer Series in Chemical Physics. Vol. 13. Berlin, Heidelberg, New York: Springer 1982
- Belfrage, Ch., Hörbäck, S., Levinson, C., Lindgren, I., Lundberg, H., Svanberg, S.: Z. Phys. A - Atoms and Nuclei **316**, 15 (1984)
- Young, W.A., Mirza, M.Y., Duley, W.W.: Opt. Commun. **34**, 353 (1980)
- Farley, J., Wing, W.H.: Phys. Rev. A **23**, 2397 (1981)
- Gallagher, T.F., Cooke, W.E.: Phys. Rev. Lett. **42**, 835 (1979)
- Dodd, J.N., Series, G.W.: Progress in Atomic Spectroscopy. Part A. Hanle, W., Kleinpoppen, H. (eds.). New York: Plenum Press 1979
- Ramirez, R.W.: The FFT: Fundamentals and Concepts. Tektronix Inc 1975
- CRC Handbook of Chemistry and Physics. 61st Edn. Boca Raton: CRC Press Inc 1981
- See, for instance, Lindgren, I., Rosén, A.: Case Stud. At. Phys. **4**, 93 (1974)
- Sternheimer, R.M.: Phys. Rev. **80**, 102 (1950)
- Garpman, S., Lindgren, I., Lindgren, J., Morrison, J.: Z. Phys. A - Atoms and Nuclei **276**, 167 (1976)
- Morrison, J.: J. Phys. B **6**, 2205 (1973)
- Garpman, S., Lindgren, I., Lindgren, J., Morrison, J.: Phys. Rev. A **11**, 758 (1975)
- Lindgren, I., Lindgren, J., Mårtensson, A.-M.: Z. Phys. A - Atoms and Nuclei **279**, 113 (1976)
- Rosén, A., Lindgren, I.: Phys. Rev. **176**, 114 (1968)
- Heully, J.-L., Mårtensson-Pendrill, A.-M.: Phys. Scr. **27**, 291 (1983); Phys. Rev. A **27**, 3332 (1983)
- Mårtensson, A.-M.: J. Phys. B **12**, 3995 (1979)
- Lindgren, I.: Phys. Rev. A **31**, 1273 (1985)
- Salomonsson, S.: Z. Phys. A - Atoms and Nuclei **316**, 135 (1984)
- Mårtensson-Pendrill, A.-M., Salomonsson, S.: Phys. Rev. A **30**, 712 (1984)
- Hörbäck, S., Lindgren, I.: (to be published)
- Daly, R.T., Holloway, J.H.: Phys. Rev. **96**, 539 (1954)
- Lurio, A., Prodel, A.G.: Phys. Rev. **101**, 79 (1956)

G. Jönsson
C. Levinson
A. Persson
C.-G. Wahlström
Department of Physics
Lund Institute of Technology
P.O. Box 118
S-22100 Lund
Sweden

I. Lindgren
Department of Physics
Chalmers University of Technology
S-41296 Göteborg
Sweden