



LUND UNIVERSITY

Graphical Programming Language Support for Service Oriented Architecture in Automation

Theorin, Alfred; Johnsson, Charlotta

2012

[Link to publication](#)

Citation for published version (APA):

Theorin, A., & Johnsson, C. (2012). *Graphical Programming Language Support for Service Oriented Architecture in Automation*. Paper presented at Reglermöte 2012, Uppsala, Sweden.

Total number of authors:

2

General rights

Unless other specific re-use rights are stated the following general rights apply:

Copyright and moral rights for the publications made accessible in the public portal are retained by the authors and/or other copyright owners and it is a condition of accessing publications that users recognise and abide by the legal requirements associated with these rights.

- Users may download and print one copy of any publication from the public portal for the purpose of private study or research.
- You may not further distribute the material or use it for any profit-making activity or commercial gain
- You may freely distribute the URL identifying the publication in the public portal

Read more about Creative commons licenses: <https://creativecommons.org/licenses/>

Take down policy

If you believe that this document breaches copyright please contact us providing details, and we will remove access to the work immediately and investigate your claim.

LUND UNIVERSITY

PO Box 117
221 00 Lund
+46 46-222 00 00



Graphical Programming Language Support for Service Oriented Architecture in Automation



LUND UNIVERSITY

Alfred Theorin
alfred.theorin@control.lth.se

Charlotta Johnsson
charlotta.johnsson@control.lth.se

Department of Automatic Control

LUND UNIVERSITY

Challenges in manufacturing

- Faster set-up
- Faster adaptations
- Customizable products
- Better vertical integration
- Manufacturing equipment is becoming more complex

Service Oriented Architecture (SOA) is a promising technology to tackle these challenges, e.g. SIRENA [2] and SOCRADES [1][3]. One outcome of SIRENA was a web service profile for embedded devices, i.e., Devices Profile for Web Services (DPWS).

Grafchart

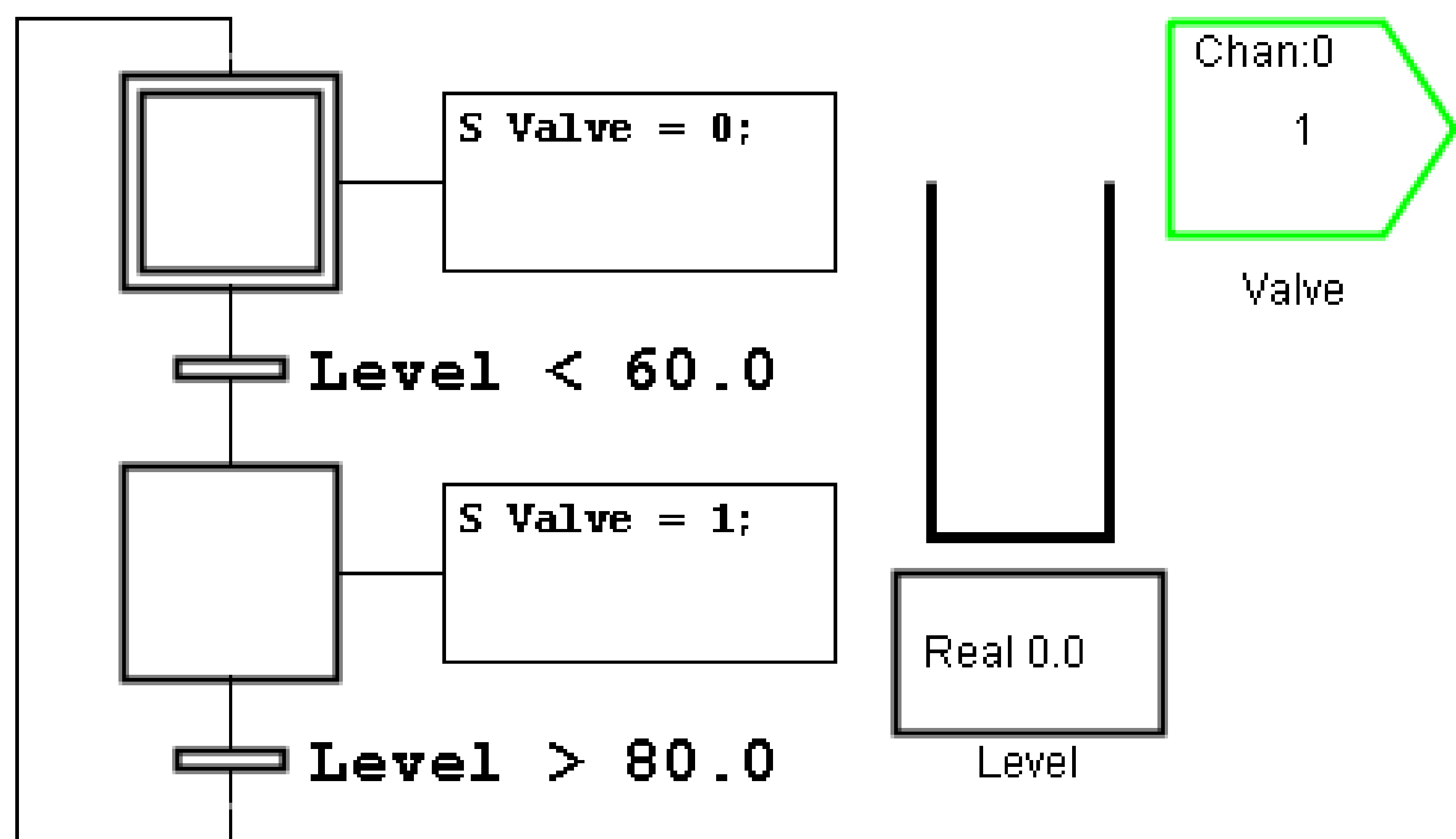

Grafchart is a graphical programming language for sequential control applications. Graphical programming is intuitive as it allows programming that mimics the way people model problems.

DPWS

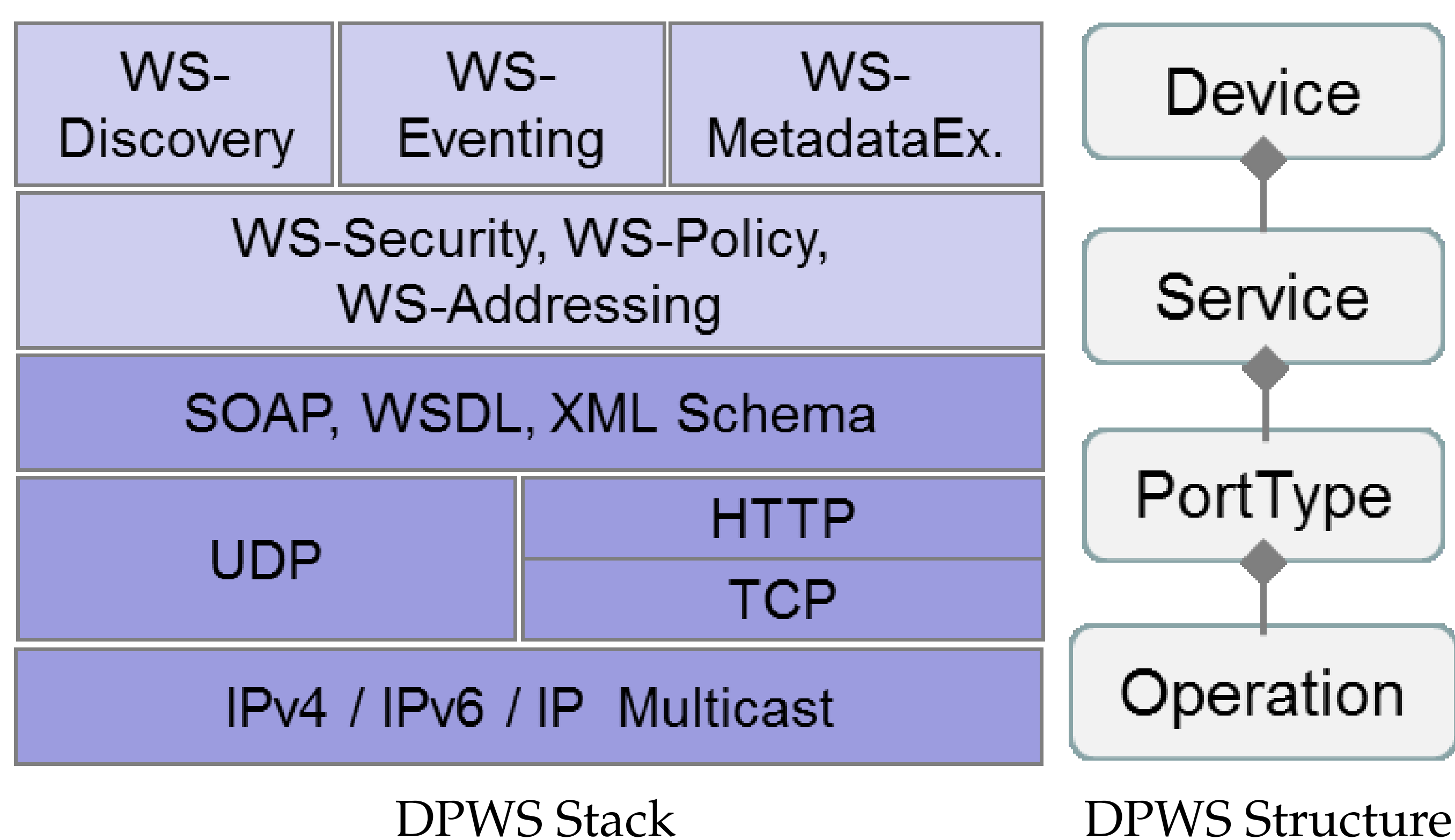

All DPWS devices are discoverable (WS-Discovery) and self-describing (WS-MetadataExchange), meaning that all information required to use a DPWS device can be obtained from the device itself, e.g. its IP-address, operations, and operation signatures.

Grafchart DPWS Integration

Generic DPWS support that is easy to use has been added to Grafchart [4], enabling anyone to try out SOA for automation with minimal effort. Simply create a DPWS Object, bind it to the Port-Type of a DPWS device, and then just call the operations.

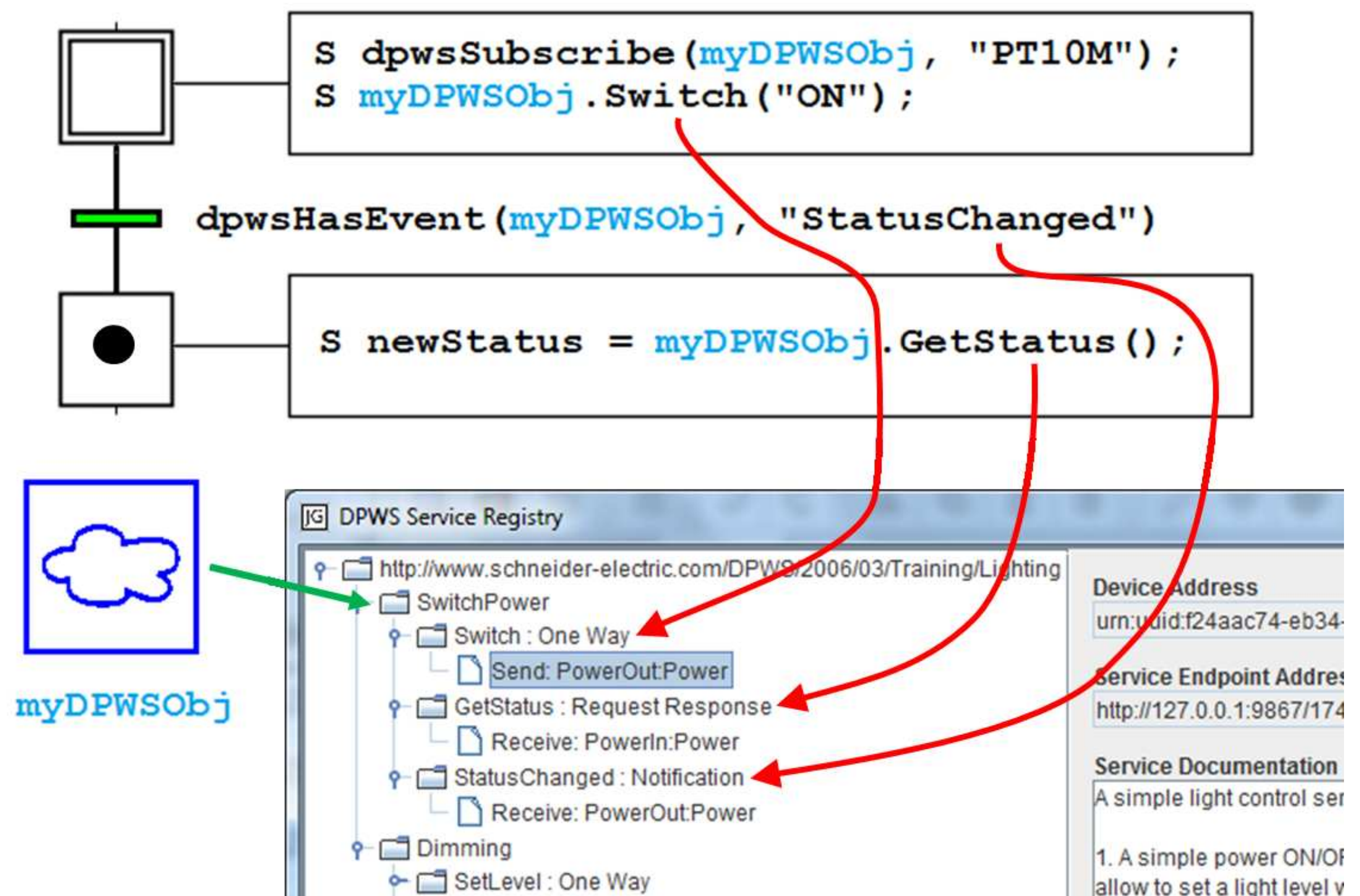

SOA Demonstrator

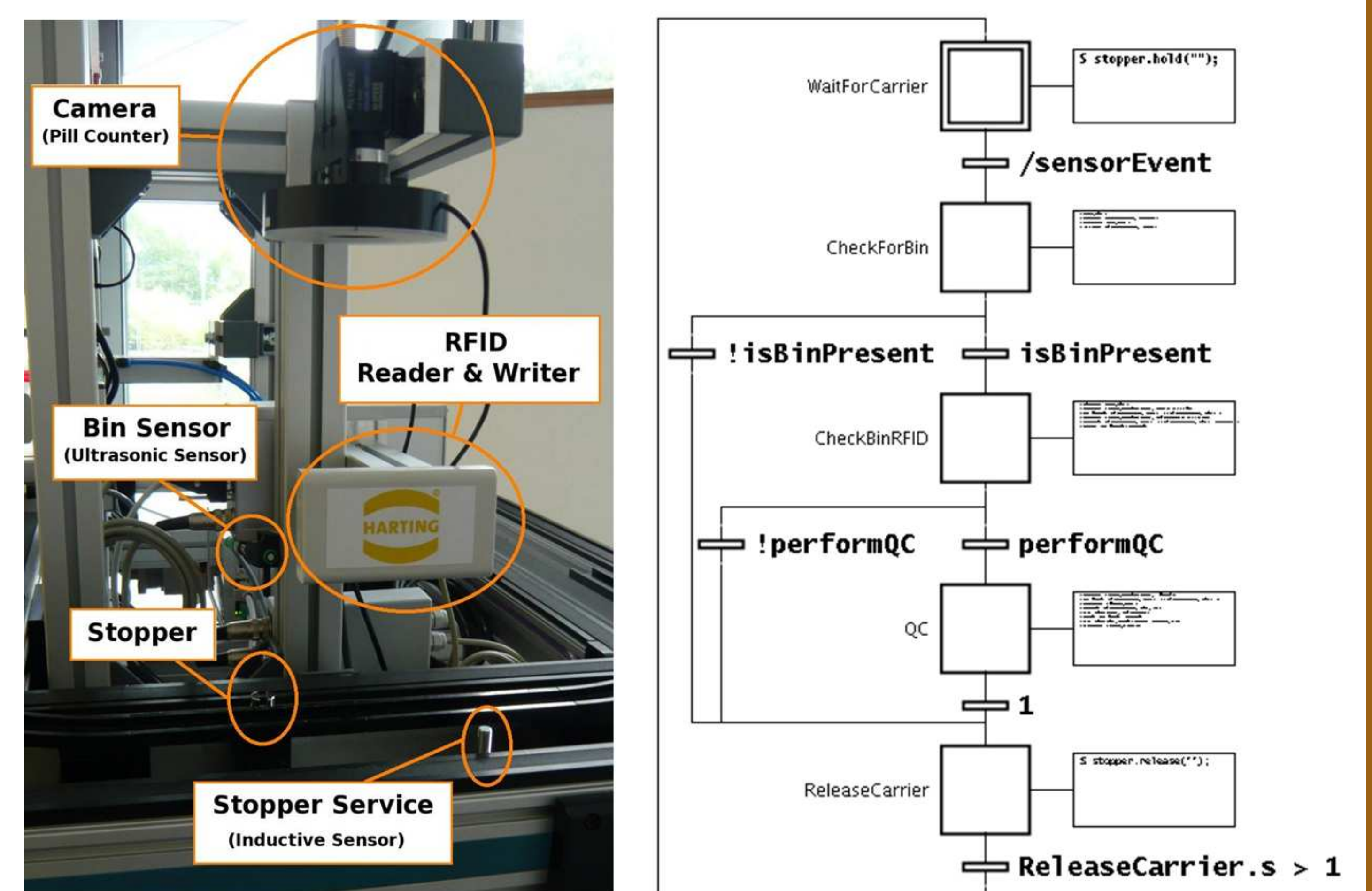

The DPWS implementation in Grafchart was tried out on a quality control station of SmartFactory^{KL}'s SOA demonstrator, checking if bins have been filled with the correct number of pills.

When a carrier arrives, one should check that there is a bin on it, if so the status of the bin should be read, and if it is ready for quality control then it should be executed. Not only was it possible to implement this using DPWS in Grafchart, but the application actually looks like one would model the process conceptually.

Acknowledgements

We would like to thank Lisa Ollinger at TU Kaiserslautern, Tobias Gerber at DFKI, and the SmartFactory^{KL} demonstration platform.



[1] De Souza, L M S, Spiess, P., Guinard, D., Köhler, M., Karnouskos, S., and Savio, D. *Socrades: A web service based shop floor integration infrastructure* In First Int. Conf. on Internet of Things (IOT), Zurich, Switzerland, March, 2008.

[2] Jammes, F., Mensch, A., and Smit, H. *Service-oriented device communications using the devices profile for web services* In MPAC, 2005.

[3] Kirkham, T., Savio, D., Smit, H., Harrison, R., Monfared, R.P., and Phaithoonbuathong, P. *SOA middleware and automation: Services, applications and architectures* In 6th IEEE Int. Conf. on Industrial Informatics (INDIN), July, 2008.

[4] Theorin, A., Ollinger, L., and Johnsson, C. *Service-oriented Process Control with Grafchart and the Devices Profile for Web Services* In Proc. of the 14th IFAC Symp. on Information Control Problems in Manufacturing (INCOM), Bucharest, Romania, May, 2012.