



# LUND UNIVERSITY

## Moisture Buffering in the Indoor Environment

Svennberg, Kaisa

2006

[Link to publication](#)

*Citation for published version (APA):*

Svennberg, K. (2006). *Moisture Buffering in the Indoor Environment*. [Doctoral Thesis (compilation), Division of Building Physics]. Byggnadsfysik LTH, Lunds Tekniska Högskola.

*Total number of authors:*

1

### General rights

Unless other specific re-use rights are stated the following general rights apply:

Copyright and moral rights for the publications made accessible in the public portal are retained by the authors and/or other copyright owners and it is a condition of accessing publications that users recognise and abide by the legal requirements associated with these rights.

- Users may download and print one copy of any publication from the public portal for the purpose of private study or research.
- You may not further distribute the material or use it for any profit-making activity or commercial gain
- You may freely distribute the URL identifying the publication in the public portal

Read more about Creative commons licenses: <https://creativecommons.org/licenses/>

### Take down policy

If you believe that this document breaches copyright please contact us providing details, and we will remove access to the work immediately and investigate your claim.

LUND UNIVERSITY

PO Box 117  
221 00 Lund  
+46 46-222 00 00

# Moisture Buffering in the Indoor Environment

**Kaisa Svennberg**  
Doctoral Thesis



Building Physics LTH  
Lund University  
Box 118  
S-221 00 Lund  
Sweden

ISRN LUTVDG/TVBH--06/1016--SE(210)  
ISSN 0349-4950  
ISBN 91-88722-36-8  
©2006 Kaisa Svennberg

The articles are printed with the  
permission of the publishers.

*To Cecilia, Renny  
and Henrik*

Den mätta dagen, den är aldrig störst.  
Den bästa dagen är en dag av törst.  
*"I rörelse" av Karin Boye*

The sated day is never first.  
The best day is a day of thirst.  
*"In motion" by Karin Boye  
in translation by David McDuff*



# Preface

This Ph.D.-project ‘Moisture buffering in surface materials exposed to the indoor air’ has been carried out at Building Physics LTH, Lund University. It was affiliated to the research school ‘the Building and its Indoor Environment’, and the Moisture Research Center at Lund University.

The project was funded by FORMAS – the Swedish Research Council for Environment, Agricultural Sciences and Spatial Planning, SBUF – the Development Fund of the Swedish Construction Industry, KK-stiftelsen – the Swedish Foundation for Knowledge and Competence Development and Byggrådet Malmö-Lund – the Council of Building Contractors in Malmö-Lund, which is gratefully acknowledged

To be a Ph.D.-student can sometimes best be described as a lonely walk down a boulevard of broken dreams, but I have had the fortune to be surrounded by encouraging and supporting colleagues, friends and family members during my years as a PhD student. I wish to express my deepest gratitude to everyone that, in one way or another, has helped me fulfill my dream.

At the end of the road, the contributions from the following persons need to be acknowledged:

My supervisors over the years: Prof. Arne Elmroth – gave me the opportunity to start this journey; Dr. Lars-Erik Harderup – initiated the project and always encouraged me to stay on track; Assoc. Prof. Lars Wadsö – shared his enthusiasm, laboratory ideas and skills with me; and Prof. Jesper Arfvidsson – introduced me to the international work groups, Nordtest and IEA Annex 41, within this field. For the time and knowledge, they all generously shared with me over the years, I am truly thankful.

Professor Johan Claesson has been a patient guide into the world of mathematics and modeling. Lilian Johansson, Agneta Ohlsson and Birgitta Salmi have provided invaluable support and help with practical matters. Stefan Backe and Bengt Nilsson made my experimental work swifter with their help.

Dr. Carsten Rode and his research group at DTU in Denmark - for the many valuable insights our collaboration has provided.

My colleagues within the House Dust Mite projects in Sweden, England and Scotland for interesting and encouraging discussions on an evident application of moisture buffering - beds.

My fellow Ph.D-students at Lund University and elsewhere have given me reasons to laugh at least once a day and have thereby shortened this Ph.D. journey considerably and most likely prolonged my life. A special thanks to Katja Fridh - for being Katja, Dennis Johansson - for endless solutions to both technical and ecclesiastic problems, and Ingemar Segerholm, CTH, Lone Mortensen, DTU and Ann Dueck, Clay Technology – for good collaboration with the papers we have written together. I am also in debt to the other co-authors of the papers appended to this thesis – thank you for important contributions to this thesis.

Desiré, Donita, Ingela, Lynne-Corrine, Dennis, and Stephen, read and commented on the manuscript, in different parts and stages, making it more legible. Their help has been invaluable. The remaining errors are solely my own.

My ‘scientific girl-friends’ –Anette Larsson, Annika Rickne, Cecilia Gagné, Ingela Hellberg, Katja Fridh, and my best friend Lena Eliasson – our discussions, on life and science, have always provided a valuable resort.

My mother- Inger Gertsdotter – for always being somewhere, and constantly encouraging me to pursue the quest for an answer. I believe the most valuable that was handed down to me by my parents, Inger and Renny, was the thirst for knowledge, without it I would never have walked down this road.

The rest of my world-wide family, the Volkwijns, the Svennbergs, the Panschas and, ‘Dad’, for all the care, support and practical help they have provided.

My children - Cecilia and Renny - since they are true rays of sunshine. Loving, encouraging, and always reminding me that the most important question is ‘Why?’ and that there is more to life than Building Physics.

Henrik, my love, hero and true companion, who has taken the lion’s share of household work and practical responsibilities in our home to enable me to complete this journey. His unconquerable optimism and offbeat problem solutions has given valuable contributions both to my Ph.D. work and our everyday life. But most of all – his endless love has given me the confidence to both start and end this journey.

*Onsala – in the sun, April, 2006*

*Kaisa Svennberg*

# Abstract

Moisture buffering in the indoor environment is the ability, through absorption and desorption, of surface materials to attenuate the moisture variations of the indoor air. Moisture buffering plays an important role in understanding the risks for biological growth in surface materials in the indoor environment, e.g., mold growth on walls and house dust mites in beds, and thereby also have an impact on the health of the inhabitants. Apart from the health aspects, moisture buffering is also important to take into account in hygrothermal calculations as well as for design of indoor climate systems.

The interaction between surface materials and the humidity of the indoor air is the scope of this Ph.D.-project reported in this thesis. The main objective is to enhance the understanding of the moisture buffering of surface materials in the indoor environment. The focus has been on moisture buffering in textile materials and upholstered furniture, common to Scandinavia.

The moisture buffering has been investigated through experimental work, field measurements and modeling. The experimental work covers development of laboratory methods and determination of basic material properties to full scale climatic chamber measurements.

A definition scheme regarding the moisture buffering in the indoor environment, at three spatial levels –material, component and room level, is proposed. Within the project, a method, to determine sorption isotherms has been developed. The moisture sorption properties for textile materials, common in the indoor environment, have been determined. The moisture conditions in a chair seat and in two bed systems have been investigated through climatic chamber measurements and field measurements, respectively. Both types of upholstery have also been studied through mathematical models. The impact of furniture and furnishing, on moisture buffering performance, was studied in a full scale climatic chamber study.

The main conclusion from the project is that moisture buffering in furniture and furnishing will be important in the moderation of indoor humidity variations with short time scales (hours and days).

**Keywords:** moisture buffering, furniture, textiles, beds, indoor air, indoor environment, sorption isotherms, field measurements, definition scheme.



# Sammanfattning

Fuktbuffring i inomhusmiljön är ytmaterialens förmåga att, genom absorption och desorption, dämpa luftens fuktighetsvariationer. Fuktbuffring spelar en viktig roll i förståelsen av risker för biologisk tillväxt i ytmaterial, t.ex. mögel på väggar och husdammskvalster i sängar. Därigenom är fuktbuffring viktig ur hälsosynpunkt. Förutom hälsoaspekterna är kunskap om fuktbuffring också viktig vid fukt- och energiberäkningar i byggnader och vid dimensionering och utformning av klimatanläggningar

Detta doktorandprojekt som rapporteras i denna avhandling omfattar samverkan mellan ytmaterial och luftens fuktighet inomhus och målet är att öka förståelsen av och kunskapen om fuktbuffring i inomhusmiljön. Ett särskilt fokus har varit fuktbuffring i textila material och stoppade möbler.

Fuktbuffring har studerats genom praktiska försök, fältmätningar och modellering. De praktiska försöken har omfattat utveckling av försöksmetoder, bestämning av grundläggande material och egenskaper och klimatkammarförsök

Ett definitionsschema för fuktbuffring på tre nivåer i inomhusmiljön, material, komponent och rumsnivå, har utarbetats. Inom projektet har en metod för bestämning av sorptionsisotermer utvecklats. Sorptionsegenskaperna hos textila material, som är vanligt förekommande inomhus, har bestämts. Fukttillståndet i en stol och två olika typer av sängar har studerats genom klimatkammarmätningar och fältmätningar. Dessa stoppade möbler har också studerats genom matematisk modellering. Inredningens påverkan på fuktbuffring har studerats i ett klimatkammarförsök i full skala.

Den väsentligaste slutsatsen från projektet är att fuktbuffring i möbler och inredning är betydelsefulla inomhus för dämpningen av fuktighetsvariationer med korta tidsskalor (timmar och dagar).

**Nyckelord:** fuktbuffring, möbler, textilier, sängar, inomhusluft, inomhusmiljö, sorptionsisotermer, fältmätningar, definitionsschema.

# Contents

Preface .....	5
Abstract.....	7
Sammanfattning.....	8
Contents .....	9
List of appended papers.....	10
Nomenclature .....	11
1 Introduction.....	13
2 Moisture buffering – state of the art .....	15
2.1 The moisture balance of a room.....	15
2.2 Materials exposed to the indoor air .....	17
2.3 Relevant material properties.....	20
2.4 Moisture buffering definitions .....	26
3 Experimental, analytical and numerical methods .....	32
3.1 Laboratory methods .....	32
3.2 Climatic chamber measurements .....	36
3.3 Field-measurements .....	36
3.4 Step-response model .....	37
3.5 One-dimensional dynamic network model .....	39
4 Main results.....	42
4.1 The definition scheme for moisture buffering.....	42
4.2 Surface materials of the indoor environment .....	43
4.3 Upholstered furniture – two examples of material systems .....	47
4.4 Moisture buffering performance of a room.....	54
5 Discussion .....	57
6 Conclusions.....	59
7 Future work.....	60
Additional publications by the author.....	62
References .....	64

# List of appended papers

## Paper I

### **Some Previous Experimental Studies and Field Measurements of Moisture Buffering in Indoor Surface Materials**

Svennberg, K., Lengsfeld, K., Harderup, L-E. and Holm, A.  
(submitted to *Journal of Building Physics*)

## Paper II

### **An Experimentally Simple Method for Measuring Sorption Isotherms**

Wadsö, L., Svennberg, K. and Dueck, A. (2004).  
Published in *Drying Technology* 22(10): 2427-2440.

## Paper III

### **Performance of Edge Sealing Systems Used in Moisture Transport Experiments**

Svennberg, K. and Segerholm, I. (2006).  
Accepted for presentation at the 3<sup>rd</sup> *International Building Physics Conference*.  
Montreal, Canada.

## Paper IV

### **Sorption Isotherms for Textile Fabrics, Foams and Batting Used in the Indoor Environment**

Svennberg, K. and Wadsö, L. (submitted to *the Journal of the Textile Institute*)

## Paper V

### **Moisture Uptake in a Chair Seat as a Response to Daily RH Variations in the Indoor Air. Climatic Chamber Measurements and Calculations**

Svennberg, K., Claesson, J. and Hansen Kielsgaard, K.  
(submitted to *Building and Environment*)

## Paper VI

### **Microclimates in Beds - Field-measurements and Simulation of Temperature and Moisture Conditions in two bed systems**

Svennberg, K., Claesson, J. and Wadsö, L.  
(submitted to *Building and Environment*)

## Paper VII

### **Moisture Buffer Performance of a Fully Furnished Room**

Svennberg, K., Hedegaard, L. and Rode, C. (2004)  
Published in the *Proceedings of the 9<sup>th</sup> International Conference on Performance of the Exterior Envelopes of Whole Buildings*. Clearwater Beach, FL, USA, ASHRAE.

# Nomenclature

$A_c$	Area of condensation	$m^2$
$A_{sj}$	Area of the surface material $j$	$m^2$
$b_m$	Moisture effusivity	$\frac{m}{\sqrt{s}}$
$c$	Specific heat capacity	$J/(kg\ K)$
$C$	Heat capacity	$J/K$
$C_v$	Hygic capacity	$m$
$d$	Thickness	$m$
$D_p$	Diffusion coefficient with vapor pressure as potential	$kg/(m\ s\ Pa)$
$D_v$	Diffusion coefficient with vapor content as potential	$m^2/s$
$g_{mbj}$	Sorbed moisture flux for material $j$	$kg/(m^2s)$
$G_{ms}$	Moisture supply	$kg/s$
$K$	Thermal conductance	$W/K$
$K_v$	Hygic conductance	$m/s$
$L$	Length	$m$
$M$	Mass	$kg$
$m_f$	Final mass	$kg$
$m_i$	Initial mass	$kg$
$q$	Ventilation rate	$m^3/s$
RH	Relative humidity	%
$t$	Time	$s$
$t_p$	Period time	$s$
$u$	Moisture ratio mass by mass	$kg/kg$
$v$	Vapor content	$kg/m^3$
$v_l$	Final vapor content (for a step-change)	$kg/m^3$
$v_{in}$	Initial vapor content (for a step-change)	$kg/m^3$
$v_e$	Exterior vapor content	$kg/m^3$
$v_i$	Interior vapor content	$kg/m^3$
$v_s$	Saturation vapor content	$kg/m^3$
$v_{sat}$		

$v_{ss}$	Saturation vapor content at the surface	$\text{kg/m}^3$
$V$	Volume of the room	$\text{m}^3$
$w$	Moisture content mass by volume	$\text{kg/m}^3$
$x_p$	Penetration depth	$\text{m}$
$Z_v$	Vapor resistance	$\text{s/m}$
$\beta_v$	Surface moisture transfer coefficient	$\text{m/s}$
$\delta_p$	Water vapor permeability with vapor pressure as potential	$\text{kg}/(\text{m s Pa})$
$\delta_v$	Water vapor permeability with vapor content as potential	$\text{m}^2/\text{s}$
$\varphi$	Relative humidity (RH)	$(\text{kg/m}^3)/(\text{kg/m}^3)$
$\varphi_{und}$	Undisturbed relative humidity (RH)	%
$\xi$	Moisture capacity	$\text{kg/m}^3$
$\xi_s$	Moisture capacity of the surface layer	-
$\Omega$	Equilibrium criterion	$\text{s}^{-1}$

Additional indexes used in this thesis:

$s$	Sheet
$f$	Foam

# 1 Introduction

The relationship between the humidity of the indoor air and the health of the inhabitants has been a matter of discussion for at least a century. The issue was for example debated 1911-13 in the well-reputed scientific journal *Science*, focusing on how to avoid relative humidities below 40% RH during the winter season. Ingersoll (1913) let 100 l [sic] of water evaporate each day in his 565 m<sup>3</sup> house. On cold days this attempt gave rise to “very annoying condensation effects”, especially in the upholstered furniture of the bedroom. An effect that perhaps could be denoted as a ‘severe case’ of moisture buffering in the indoor environment.

Moisture buffering is the ability, through absorption and desorption, of surface materials in the indoor environment to dampen the moisture variations of the indoor air. Both the inside surfaces of the building envelope – ceilings, floors and walls – as well as the furniture and other furnishing, will give an impact on the moisture conditions in the room. Naturally not only the moisture condition of the indoor air is affected but also the moisture conditions in the materials acting as moisture buffers.

Almost one hundred years after Ingersoll’s experiment, the reason to study moisture buffering in the indoor environment is still the health aspects. This is in particular true for the case of bedrooms, where the moisture buffering in beds play an important role in understanding the factors that determine the climate and survival for house dust mites, a common cause of allergy. Moisture buffering will also play a significant role in understanding the risks for other type of biological growth in surface materials in the indoor environment, e.g. mold growth on walls. High moisture conditions of the surface materials are also suspected to increase the risk of chemical emissions from the surface materials to the indoor air. Apart from the health aspects moisture buffering is also important to take into account in hygrothermal calculations as well as for design of climate systems and energy demands.

The interaction between surface materials and the humidity of the indoor air is the scope of this Ph.D.-project and the main objective is to enhance the understanding of the moisture buffering of surface materials in the indoor environment. In order to accomplish this objective the project has included experimental work, mathematical modeling and literature surveys. The focus of the experimental and modeling work reported here is moisture buffering in furniture and furnishing materials typical for Scandinavia.

The study is limited to surface materials exposed to the indoor air. Only moisture variations with short time scales, such as hours and days are considered. These short time scales causes most indoor surface materials to follow a ‘scanning path’ between the absorption and desorption isotherm curves. This effect is neglected in the calculations and modeling work of this study, as we have only limited understanding of these effects. However, the experimental results clearly demonstrate a hysteresis effects for many of the investigated materials.

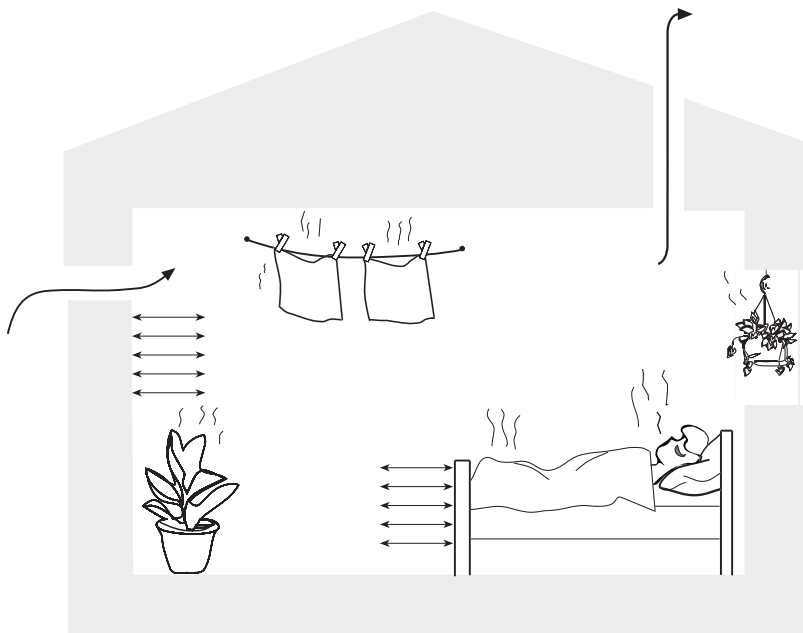
The first section in this thesis (section 2) provides a state-of-the-art of moisture buffering, and includes a description of the moisture balance of a room, an overview of typical materials of the indoor environment, literature surveys covering laboratory methods to determine moisture buffering and moisture buffering definitions. In section 3, the methodology for each part of the project is presented and discussed. The main results are presented in section 4 including a proposed definition scheme for moisture buffering in the indoor environment and four main results from the experimental and modeling work. A discussion of the main results is found in section 5 and the conclusions from the project are found in section 6. Future work is discussed in section 7.

Seven research papers are appended to this thesis. The appended papers establish the background and present the core of the main results. Papers II, III and VII are published whilst Papers I, IV-VI are submitted for publication. The papers are summarized in sections 2-4 in the context where they are the most relevant.

## 2 Moisture buffering – state of the art

### 2.1 The moisture balance of a room

The moisture balance of a room is determined by a combination of several factors. They include the outdoor climate, the moisture supply, the moisture buffering from surface materials of the room and furnishing, the ventilation rate, the possible condensation on cold surfaces and finally the variation of these parameters with time. The time scale for the moisture balance of a room can vary from seasonal, taking into account the annual fluctuations of the external climate, to diurnal, where the time scale extends from hours to days. In this project, the focus is on the short time scales, which will be affected mostly by the activities of the inhabitants (Rode, Grau et al. 2001).



**Figure 1.** *A principal picture of the moisture balance of a room in a dwelling. The moisture conditions of the indoor air is governed by the moisture production, ventilation, indoor and outdoor climate and the moisture buffering in surface materials.*



Equation 1 shows an analytical expression for the change in vapor content,  $v_i$ , of the indoor air over time. The temperature dependence of the volume expansion of the air is neglected.

$$\frac{dv_i}{dt} = \frac{\sum G_{ms} - \sum_{j=1}^n g_{mbj} A_{sj} - q(v_i - v_e) - \beta_v(v_i - v_{ss}) A_c}{V} \quad [\text{kg}/(\text{m}^3 \text{ s})] \quad (1)$$

The moisture supply,  $G_{ms}$ , is assumed to be composed of two parts. On the one hand a relatively constant supply from plants, inhabitants and pets. A second contribution are short moisture supply pulses that comes from; food preparation, laundry, showers, baths, and other activities that are carried out during shorter periods of the day.

The ability of the interior surfaces to buffer moisture variations of the indoor air is described by,  $g_{mb}$ , the moisture absorption or desorption in the different surface materials at a given time. The sorption in materials will dampen the moisture variations of the indoor air. Both the surfaces of the inside of the building envelope such as ceilings, floors and walls as well as the furniture and other furnishing, will give an impact on the moisture conditions in the room. The moisture buffering ability of a hygroscopic material in real use will, in most cases, be lower than the basic material properties suggest. This is due to sorption isotherm hysteresis and the fact that in most real situations, the surface materials of the indoor environment follow a scanning path with considerably lower moisture capacity. Surface coating and treatments will also reduce the moisture capacity of surface materials.

The ventilation is crucial for the moisture condition of indoor air. The ventilation flow rate,  $q$ , is set to a minimum of 0.35 l/s per  $\text{m}^2$  floor area in the Swedish building code (BBR 2002), but for most applications the advice is to have an even higher air exchange. The main purpose of the ventilation is to supply the building and its inhabitants with sufficient amount of fresh air, remove emissions from activities, people and materials, and to remove excess moisture, smells and hazardous substances. The impact of the ventilation, on the RH in a room, depends on the ventilation rate, and the vapor content of the indoor and the outdoor air. If the ventilation rate is high, it will control the RH of indoor air to a high degree. If on the other hand the ventilation rate is low, the impact of moisture buffering in surface materials is larger (Christoffersen 1996).

## **2.2 Materials exposed to the indoor air**

The materials exposed to indoor air are a heterogeneous group of materials, from heavy concrete used in the building construction to lightweight textiles found in furniture and furnishings. Several of the materials used indoors are polymers like wood, cotton and paper. However, the materials exposed to the indoor air will often, in one way or another, have a surface coating. The aim of this overview is to briefly describe the characteristics of commonly used materials in the indoor environment.

### **2.2.1 Wood and wood-based materials**

Wood and wood based materials are used both in building constructions and in furniture. The surface coatings used on wood can vary from none at all for a wooden ceiling to the convertible coating on parquet flooring.

Wood has a heterogeneous structure based on its fibrous composition. The moisture uptake rate is determined to a high degree by the orientation of the fiber strands in relation to the moisture source. The moisture uptake rate is approximately 1:2:20 in the directions tangential, radial and parallel to the fiber, respectively.

The moisture properties are also determined by the species of wood used and the location in which it grew in. Wood can be divided into softwoods and hardwoods, based on the species. Hardwood (deciduous tree) has often lower moisture permeability than softwood (coniferous tree).

Wood and wood based materials have a rather high moisture capacity and the moisture-induced deformations, such as swelling, is usually noticeable. Since wood is an organic material, the degradation process due to biological growth is moisture related involving, e.g., mold, rot, bacteria and various insects.

### **2.2.2 Textiles and upholstery**

Textiles are used in furniture and furnishings such as curtains, carpets and bedding. Textiles, compared with most traditional building materials, have a more mesh-like structure which makes them lighter and more permeable. Yarn can be made from a number of fiber types, e.g., wool, cotton, flax, viscose and nylon. The moisture properties of the fibers in combination with the weaving technique give each fabric its unique moisture properties. The upholstery of furniture can be made from a variety of materials, e.g., polyether foam (a flexible polyurethane foam based on ether-type polyol), cotton, down, wool,

straw and horsehair. The textile materials usually have large moisture capacity but low density. However, textiles in furniture and furnishing are common in the indoor environment and, as they to some extent ‘hide’ traditional building materials; they play an important role in regulating the moisture variations of indoor air, especially for short time scales.

Upholstered furniture, especially beds and carpets, are the main habitats for house dust mites, a common cause for allergy.

### **2.2.3 Paper**

Paper found in the indoor environment can be of different types. Books, newspapers and magazines are one major part of the paper in the indoor environment exposed to the indoor air. Wallpaper made from paper is another, even if they usually have additional surface coatings such as paint or vinyl film. The way in which the paper products are stored or exposed to indoor air will also influence the impact of the moisture buffering they provide.

### **2.2.4 Gypsum board and gypsum**

Gypsum board is a gypsum-based board, and the indoor type used in Scandinavia is usually covered with heavy paper on both sides. Gypsum board is used for interior walls and ceilings. Usually a surface coating such as wallpaper or paint is used.

Gypsum based plasters are commonly used indoors in the southern parts of Europe and play an important role in the moisture buffering performance of the room.

### **2.2.5 Cementious and ceramic materials**

Concrete and aerated concrete is used for walls, floors and ceilings. The walls are usually surface coated in the same way as the gypsum board and concrete ceilings are mostly painted. On concrete floors a layer of screed is usually applied, and after that a flooring material, for example PVC-flooring, laminate flooring or ceramic tiles, is applied. Most concrete surfaces are therefore not immediately exposed to the indoor air.

The composition of plasters and mortars can vary from pure lime mortar to pure cement mortar. The water vapor permeability decrease with the water/cement-ratio of the mortar.

Ceramic tiles often have a glazing, giving them an almost impermeable surface for the diurnal time scale. If the ceramic tiles are unglazed, they have similar properties as brick. The mortar used to fill the joints between tiles is more porous and can, in theory, add to the moisture buffering capacity. However, if this area is small the moisture buffering of the joints can be neglected.

Bricks without surface coating have a low moisture capacity in the RH interval of interest for normal indoor environments. Sometimes when brick is used in large volumes in, e.g., classrooms and churches, the moisture buffering of the brick cannot be neglected. Plasters are used with or without paint to surface coat bricks. The moisture buffering ability will then depend on the paint and plaster used to a high degree.

## **2.2.6 Surface coatings and finishing materials**

Surface coatings are often based on polymers, e.g., latex paint, wax and plastic films. In the indoor environment, surface coatings vary from sparse and diffusion open oil treatments to thick and almost impermeable enamel paints. The surface resistance of a surface coating is dependent on the material used, and on the application. If there is a ‘heavy’ surface coating on the top surfaces of furniture, e.g., a wooden table, usually the side underneath will be untreated. Therefore, an estimation of the accessibility of indoor air to the potential moisture buffering areas has to be included in an estimate of the moisture buffering performance.

Oil and wax treatments are mostly used on wood flooring, furniture and furnishing. The treatment has to be repeated to maintain the surface coating desired. Therefore, the surface resistance of the coating may vary over time.

Paints are a broad and heterogeneous group of surface coatings that goes from whitewash to convertible coating. For surface coating of building components, latex paint is most commonly used in the indoor environment. Furniture and furnishing can be varnished or lacquered using alkyd paint. Whitewash (or distemper) and temper paints are considered to be more ‘open paints’ with a lower surface resistance.

Common wallpapers are coated either with paint or with a vinyl film to make the surface cleanable. Adhesive, and in some cases primer, belong to the wallpaper system. In Sweden, glass fiber backings with different surface structures are used under the coats of paint. There are also wallpapers with textile surface top layers.

Polymeric foils are mostly used for furniture, furnishing and floorings. Usually they are applied on board materials as chipboard or MDF boards.

### 2.2.7 Other materials

Stainless steel and other metals as well as glass do not have any moisture buffering capacity. Their thermal properties will in some locations give them a lower surface temperature than the room air and could cause condensation.

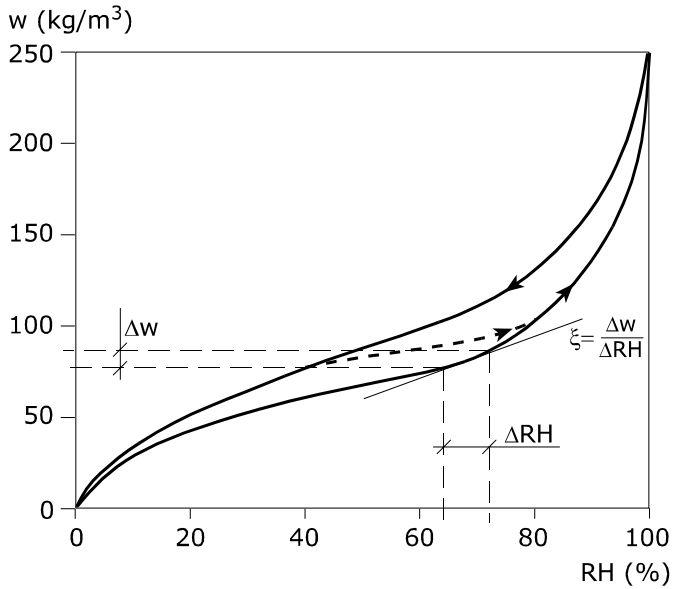
There are a number of plastic materials, for example in floorings and furniture, in the indoor environment, whose moisture properties are not homogeneous due to both the differences in composition and the use of the material.

## 2.3 Relevant material properties

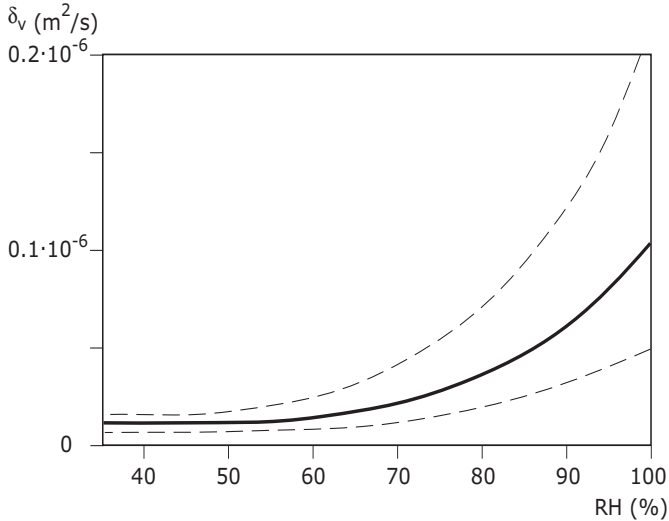
The basic moisture related material properties of the materials present, as well as their distribution in the room and the accessibility for exposure to the indoor air, are of importance for the effect of the moisture buffering. The basic material properties often depend on the moisture conditions of the material and are non-linear, they are also temperature dependent.

For most materials, a hysteresis effect is seen for the absorption/desorption properties as shown in Fig. 2. In the case of moisture buffering the material will be experiencing daily or seasonal variations. Therefore, the sorption properties are governed by scanning curves, an example of a scanning curve is shown in Fig. 2 by a thick dashed line. The scanning, due to hysteresis, will limit the slope of the isothermal sorption curve, and the effective moisture capacity of the material will be significantly reduced.

The water vapor permeability ( $\delta_v$  or  $\delta_p$ ) or the vapor diffusion coefficient ( $D_v$  or  $D_p$ ) expresses the mass of water vapor that diffuses through a material per time unit and unit area under a moisture gradient (the vapor content,  $v$ , or the vapor pressure,  $p$ ). The water vapor permeability is a nonlinear function of the RH for many materials, see Fig. 3. Ageing and surface treatments, also including staining and soiling, will introduce a time dependence effect in the basic material properties for the materials. This time dependence is related to the moisture conditions of the material, and difficult to estimate.



**Figure 2.** An example of a sorption isotherm for laminate flooring. The slope of the curve defines the moisture capacity. The thick dashed line is a scanning curve. Data from (Hedenblad 1996)



**Figure 3.** The water vapor permeability for laminate flooring as a function of the relative humidity. The dashed lines show the uncertainty, 95% confidence interval, of the measurements. Data from Hedenblad (1996).

A literature survey considering methods to determine sorption isotherms and water vapor permeability, has been conducted within the project. The scope of the survey was simple and inexpensive methods appropriate for materials in the indoor environment. A special focus was on thin and permeable materials since this type of materials are not usually dealt with in building science. The literature survey presented here in section 2.3.1 -2.3.3 should only be seen as a taste of the buffet of methods and modifications available. A large literature survey covering a broad field of the interaction between surface materials and the indoor air was conducted in a preliminary study for this Ph.D.-project (Harderup, 1998).

### **2.3.1 Sorption isotherm methods**

Most methods for determining sorption isotherms - equilibrium water gain as a function of RH - rely on equilibration over saturated salt solutions that keep a constant RH (Greenspan 1977; Nyqvist 1983) combined with gravimetric methods to determine the moisture content in the samples, e.g., Wolf, Spiess et al. (1984) and Chirife and Buera (1995). Unsaturated salt solutions (Chirife and Resnik 1984; Clarke and Glew 1985) or sulphuric acid solutions of different molecular concentration, (Speakman and Cooper 1936) have also been used as humidity generators.

In these simple methods the samples are usually weighed outside the RH controlled environment. This may lead to significant errors, especially for thin samples. Gustafson & Hall (1974) and Zuritz et al. (1979) made attempts to solve this problem by using separate jars with lids for each sample, a work that was continued in the present project.

Saturated salt solutions are also used as humidity generators in small climate chambers where dynamic measurements can be performed e.g., Wadsö (1993), Time (2002) and Ojanen and Salonvaara (2003).

McBain and Baker (1926) developed another gravimetric method using a spring balance made of quartz in a vacuum tube. The elongation of the spring is used to determine the vapor uptake. The method can be used not only for water vapor, but also for other vapors, since the method use liquids as a vapor source.

Peralta (1995) used a combination of quartz spring balances, vacuum equipment and saturated salt solutions to determine sorption isotherms for wood samples.

Automated sorption balances, e.g., IGA-sorp, DVS 1000, are microbalances in climatic chambers where the climate can be very carefully and automatically governed. The relative humidity desired is obtained by carefully mixing wet and dry air. The limitation of the method is the small sample size. (Janz and Johannesson 2001; Arlabosse, Rodier et al. 2003; Anderberg and Wadsö 2004).

Leisen et al. (2002) used a sorption balance as a humidity generator and determined the moisture uptake of the sample using nuclear magnetic resonance (NMR), which is a non-gravimetric method.

Another non-gravimetric method was developed by Wadsö & Markova (2002) using a double twin calorimeter to determine sorption isotherms. Others, for example Hansen et al. (1996), and Lehto and Laine (2000), have also used calorimetry for determination of sorption isotherms.

### **2.3.2 Water vapor permeability methods**

The water vapor permeability,  $\delta_v$ , or the diffusion coefficient,  $D_v$ , can be determined from steady state or non-steady state methods.

The most common steady state method is the cup method. In the cup method the sample is fastened as a lid over a container with a humidity generator (usually saturated salt solutions) or a desiccant. Numerous modifications and alterations of the basic cup method are possible, e.g., Newns (1950), Joy and Wilson (1965), Turl and Kennedy (1965), Hansen Kielsgaard (1990), Villadsen et al. (1993), Hedenblad (1996), and Takada et al. (2001). The different cup methods can be categorized as dry cups or wet cups depending on the content of the cup. Dry cup methods use desiccants inside the cup and a higher relative humidity outside. The vapor transport will go through the sample from the outside and in. In the wet cup methods, saturated salt solutions are usually used as humidity generators, the RH inside the cup being higher than on the outside.

The cup methods can also be divided into upright cups and inverted cups. In the upright cups there is an unavoidable air gap between the salt solution and the sample to avoid splashing the sample when doing measurements. This air gap will introduce an internal resistance of the cup. For highly permeable materials this resistance can be difficult to handle. (Newns 1950). In inverted cups, the internal resistance of the method is less since there is no air gap. On the other hand, there is a risk that the salt solution will be absorbed by the sample. A hydrophobic vapor permeable membrane between the sample and



the salt solution ensures that the moisture transport through the sample is a vapor transport (ISO/DIS 15496 2001; Svennberg and Wadsö 2003).

A modified cup method where the measurements are performed at low pressure speeds up the measurements, and give additional information about the vapor and liquid transport if the measurements are done at several ambient pressures (Galbraith 2003).

The partition cell or diffusion cell where the sample material is placed as a wall between two chambers with different climate is another steady state method e.g., Nilsson (1993). A development of this concept is the dynamic moisture penetration cell (DMPC) where both sides of the sample are subjected to air flows of well-defined RH. The RH at the inlet of the chamber is compared to the RH at the outlet, and the vapor permeability can be assessed (Gibson, Kendrick et al. 1997).

The sorption method is a non-steady state method based on a step change in the RH surrounding the sample. There are many ways to accomplish this step change. For example one could use climatic chambers as sorption balances or the jar method. It is important that the step is made as perfect as possible. Thick air boundary layers or stagnant air will give large surface resistances making the step imperfect (Wadsö 1994a; Wadsö 1994b).

The variation in results between different methods for textile materials is a problem reported by (McCullough, Myongsook et al. 2003). This imprecision decrease the reliability of the results from the vapor permeability methods used for textiles. There are two main problems with textile cup measurements. Firstly, the samples are thin and permeable so that the air gaps in most cups have significantly higher diffusion resistance. Secondly, most textiles are soft and difficult to fasten in a good way in cup measurement set-ups used for traditional building materials.

Gamma-ray attenuation and NMR for determination of the moisture diffusivity in porous materials have been used by Freitas et al. (1995).

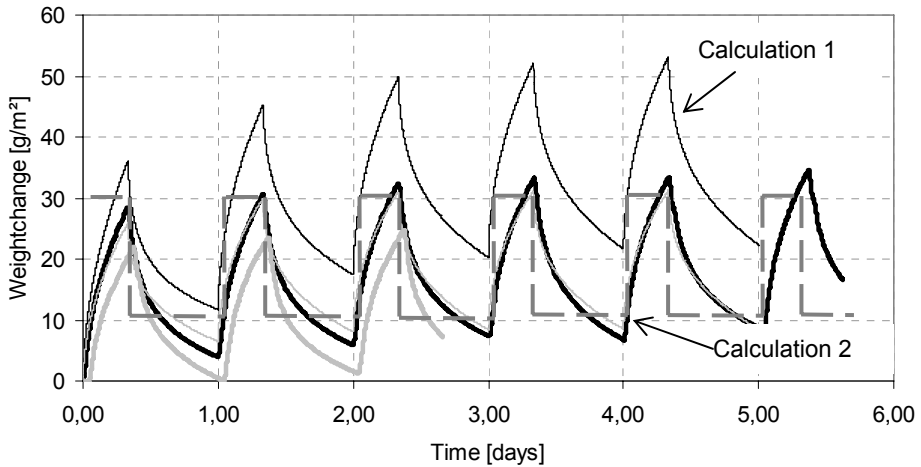
### 2.3.3 Dynamic methods for determination of moisture buffering related properties

Most standard methods to determine moisture related material properties are made under steady state conditions and thereby far from the dynamic variations seen for diurnal moisture variations in the indoor environment. A number of dynamic test methods have been established to determine the impact of moisture buffering.

Padfield (1998) developed a climate control system in which a water basin is constantly weighed. Using a heat coil in one half of the basin, humidification can be generated through vaporization of the water. The amount of vapor released in the chamber is monitored through the weight change of the basin. The other half of the basin is equipped with cooling facilities where water vapor is condensed in order to create a drying situation in the chamber. The withdrawal of vapor from the air is also monitored gravimetrically. This basic method has been employed in some climatic chambers for dynamic measurements with periodic variations, e.g., Mitamura et al. (2001), Padfield, et al. (2002); Peuhkuri and Padfield (2003).

Several experimental methods, e.g. the ‘practical moisture buffer value’,  $MBV_{\text{practical}}$  proposed by a NORDTEST work group (Rode, 2005 #491), the ‘moisture sorption efficiency’ described in the Japanese standard (JIS 2003) and the ‘water vapor absorption coefficient’ developed by Dr. H. Künzel (1965, 1968) are based on the step response of the material from single or repeated step-changes in the ambient RH.

The practical Moisture Buffer Value,  $MBV_{\text{practical}}$  is determined in an experimental set-up where the sample is exposed to cyclic step-changes in RH between high (75% RH) and low (33% RH) for 8 and 16 hours respectively. The Moisture Buffer Value is calculated as the amplitude of the weight gain/area for the final 8-hour-absorption phase of the experiment, divided by the size of the RH-interval used in the experiment. The normal test procedure is a periodical exposure of 8 h at 75% RH and 16 h at 33%, the size of the RH-interval will then be 42% RH. The Moisture Sorption Efficiency is also determined in a similar manner.



**Figure 4.** *The MBV<sub>practical</sub> test method. The dashed grey line shows the variations in RH - 8 h at 75% RH and 16 h at 33% RH. The solid grey lines represent measurements for spruce plywood performed with this mode. The black lines represent two calculations of moisture buffering using material properties determined under steady state conditions. Calculation 1 uses the moisture capacity  $dw/d\phi$  taken from the sorption isotherm and calculation 2 uses a moisture capacity  $dw/d\phi$  half the size of the one used in calculation 1. Calculation 2 will therefore use a moisture capacity  $dw/d\phi$  that is closer to the one of a scanning curve. The curve for calculation 2 coincides to a high extent with one of the measurements (thin grey line).*

One of the limitations with this type of dynamic laboratory methods and definitions is when the penetration depth of the specimen for the considered time period, cf. section 2.4.2 *Definitions based on penetration depths*, exceeds the specimen thickness (for one sided exposure) or 0.5 of the specimen thickness (for double sided exposure). If this is the case, the test conditions will exceed the theoretical limits for this type of experiments.

## 2.4 Moisture buffering definitions

The following compilation of available definitions for the moisture buffering phenomena is not complete and should only be seen as a selection. In some cases the originator of a concept or application has not been found.

The reviewed definitions and concepts are divided into four groups based either on the manner they are established or their primary use. Thus each definition or concept may be placed in several groups.

The first group of definitions is based on *laboratory measurements*, either basic material parameters or a standardized moisture load experiment. The second group of definitions all relate to the concept of *moisture penetration depth*. This can be defined in several different manners, and there are numerous ways of using this concept. The third group of definitions uses a *combination of two or more material parameters* or other definitions related to moisture buffering. The fourth group of definitions is primarily used for *ranking* materials with respect to their moisture buffering properties. These definitions are generally qualitative measures.

There are also definitions and concepts for moisture buffering using conversion to another known quantity to relate the effect of moisture buffering. This type of conversion will give little, and in some cases incorrect, information on the characteristics of the moisture buffering phenomena. Examples of quantities used for conversion of the moisture buffering are; effective ventilation, effective penetration depth and conversion of the effect of surface materials into equivalent volume of air (Kerestecioglu et al., 1990; Simonson and Salonvaara 2000; Salonvaara and Simonson, 2000).

#### **2.4.1 Definitions related to laboratory measurements**

The moisture buffering abilities of a material have been assessed by laboratory experiments based on transient as well as non-transient methods.

The moisture capacity,  $\xi$ , is a material property defined as the slope of the sorption isotherm for the chosen interval in RH ( $\Delta w/\Delta \varphi$  or  $dw/d\varphi$ ), see Fig.2. The absorption and desorption isotherms are made up by the equilibrium moisture content for each RH either during absorption and desorption. This material property for equilibrium conditions does not always reflect the transient conditions of the periodic variations in the indoor environment; neither does it take into account the surface resistance due to coatings or soiling.

The water vapor absorption coefficient developed by Künzel (1965, 1968) is based on the step response of the material from single or repeated step-changes in the ambient moisture conditions and the linear relationship found as the mass change is plotted versus the square root of time. This relationship is only valid if the sample starts from equilibrium conditions.

## Some Earlier Experimental Studies and Field-Measurements of Moisture Buffering in Indoor Surface Materials

Kaisa Svennberg, Kristin Lengsfeld, Lars-Erik Harderup & Andreas Holm  
(submitted)

The objective of this paper is to show that the interest in moisture buffering is not a new issue and that there have been significant laboratory studies made on indoor surface materials in the past. It is also an attempt to present a number of earlier studies from 1960 – 2000 on surface materials typical for indoor environment made at the Fraunhofer Institute of Building Physics, Germany and Building Physics LTH, Sweden. The review covers step response experiments in the laboratory and full scale measurements in climatic chambers and in dwellings under use. The results from these studies have not been presented in English before.

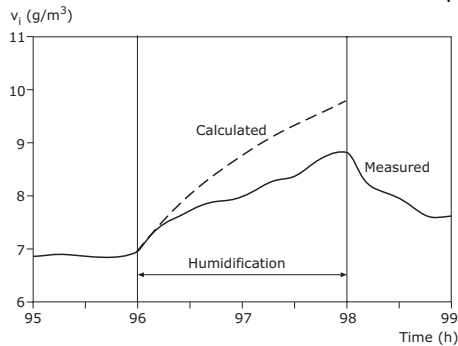


Figure 1. Comparison between measured indoor vapor content (solid line) and calculated indoor vapor content without taking moisture buffering into account (dashed line) for a house in Southern Sweden subjected to humidification by a humidifier.

The practical Moisture Buffer Value,  $MBV_{\text{practical}}$  is based on laboratory measurements as described above in section 2.3.3.  $MBV_{\text{practical}}$  is indicating the amount of water that is transported in or out of a material per open surface area, during a certain period of time, in the prescribed test method 8 hours of absorption (Rode, Peuhkuri et al. 2006), when the sample is subjected to variations in relative humidity of the ambient air.  $MBV_{\text{practical}}$  is the moisture exchange during the chosen time period reported per open surface area and per % RH variation [ $\text{kg}/(\text{m}^2 \cdot \% \text{RH})$ ].

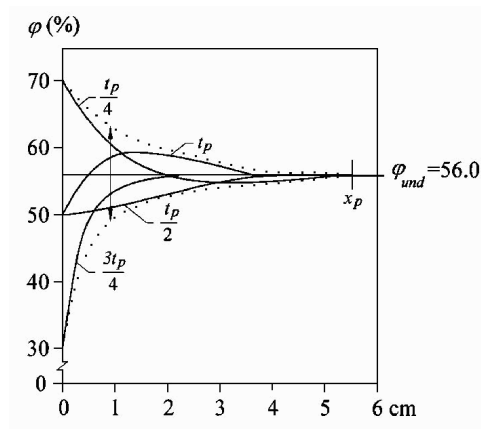
The correlation between  $MBV_{\text{practical}}$  and the sorption kinetics have recently been investigated by Delgado et al. (2006). The study shows that reliable predictions of the equilibrium moisture uptake can be obtained from the initial measurements of step response for gypsum-based materials and plywood. By combining equilibrium moisture uptake with an appropriate kinetic model for

the studied material predictions regarding the  $MBV_{\text{practical}}$  value can also be made.

## 2.4.2 Definitions based on penetration depth

The moisture penetration depth describes how deep the moisture will penetrate for a moisture variation of a certain time period e.g., 24 hours. There are a number of definitions of penetration depth e.g., Hagendoft (2001), Arfvidsson (1999), Diasty et al. (1993), Cunningham (1992.) and Künzeli and Kiehl (1990) Other nomenclature is also used to describe the concept, for example active surface layer (Künzeli and Kiehl 1990.). All these definitions have in common that they focus on the penetration of moisture from the indoor air into the material for a given time period.

The penetration depth as it is defined by (Arfvidsson 1999) for a periodic variation at the boundary of the material is illustrated in Figure 4. The curves in the figure are the moisture distribution at different times ( $t_p$ ,  $t_p/4$ ,  $t_p/2$ ,  $3t_p/4$ ) during the time period  $t_p$ . The dotted curves show the maximum and minimum values at different depths in the material. The range of relative humidity variation decreases with the depth. Let  $x_p$  be the point where the relative humidity variation is equal to 1% RH. Arfvidsson then defines this point  $x_p$  as the *penetration depth*, see Fig. 5.



**Figure 5.** Penetration depth,  $x_p$ . The relative humidity varies between a maximum (70% RH) and a minimum value (30% RH) during the period time  $t_p$  (24hours).

The way to define the penetration depth as the ‘full depth’, and not the depth were half or 2/3 of the amplitude has penetrated into the material has an

obvious advantage when we look at combined materials. If the material, closest to the boundary, in a layered construction, is thicker than the penetration depth, with this definition, one only have to consider the variations in the first material. Other ways to define the penetration depth do not give this valuable information.

### 2.4.3 Combined definitions

By combining basic moisture related material parameters with each other, or with other concepts used to describe moisture buffering, a better description of the moisture buffering ability in materials and material combination can be achieved. By combination of material parameters, the effect of surface treatments and soiling can be taken into account more easily.

The moisture effusivity,  $b_m$ , is a theoretical approach developed within the NORDTEST Moisture Buffering project, describing the ability of the material combination to take up and store moisture. The moisture effusivity can be calculated from stationary material properties for a material combination, Eq. 2 (Harderup 2005; Rode, Peuhkuri et al. 2005; Rode, Peuhkuri et al. 2006).

$$b_m = \sqrt{\frac{\delta_v \cdot \xi(w)}{v_{sat}}} \quad (2)$$

The ideal moisture buffer value,  $MBV_{ideal}$ , is a theoretical definition proportional to both the moisture effusivity,  $b_m$ , and the square root of the period time. This concept was proposed in connection to the practical moisture buffer value and the moisture effusivity.

‘Available water’ is a combined definition, closely related to the moisture effusivity, proportional to the product of the penetration depth and the moisture capacity:  $x_p \cdot \xi$  [kg/m<sup>2</sup>] (Padfield 1998).

Another combined concept is the Biot number for moisture sorption used by for example (Harderup 1983).

### 2.4.4 Ranking definitions

For uncomplicated classification purposes, straightforward definitions based on ranking the materials regarding their moisture buffering abilities, are suitable. The simplest form of ranking are qualitative judgments based either on the palpable properties of the materials such as hard-soft (Plathner and

Woloszyn 2002) or basic evaluation of laboratory experiments (Martin and Verschoor 1986) slow-fast.

The results obtained from several experimental methods, e.g. the Moisture Buffer Value proposed by a NORDTEST work group (Rode, Peuhkuri et al. 2005), the Moisture Sorption Efficiency described in the Japanese standard (JIS 2003) can be used as ranking values for different furnishing materials in the indoor environment.

Hygic inertia,  $I_h$ , introduced by Ramos and Freitas (2004), is a concept focusing on the moisture buffering performance of the complete room. The concept takes into account both surface materials of the building, the furniture and furnishings. With the hygic inertia  $I_h$  as quantity, rooms can be divided into different hygic inertia classes.



### **3 Experimental, analytical and numerical methods**

The methodological emphasis in this project has been on experimental methods. The experimental work covers development of laboratory methods and determination of basic material properties to full scale climatic chamber measurements and field measurements. The specific methods used are presented in sections 3.1-3.3. The modeling and calculations have been analytical tools to increase the understanding of the moisture buffering in surface materials and are presented in sections 3.4 and 3.5. Within this project three literature surveys have been conducted, focusing on;

- a) laboratory methods for determination of relevant material properties such as sorption isotherms and water vapor permeability, presented in section 2.3
- b) available definitions and concepts for the moisture buffering phenomena in the indoor environment, presented in section 2.4
- c) house dust mites and the microclimate in beds and bedrooms, including field measurements and modeling. Wadsö and Svennberg have presented the results from this survey in a separate report (Wadsö and Svennberg 2005)

#### **3.1 Laboratory methods**

The literature survey regarding methods for determining sorption isotherms showed that there were few inexpensive sorption isotherm determination methods, where the sample was undisturbed during the complete measurement period. Therefore, a small climatic chamber method for gravimetric sorption measurements was developed based on earlier work by Gustafson and Hall (1974) and Zuritz et al. (1979).

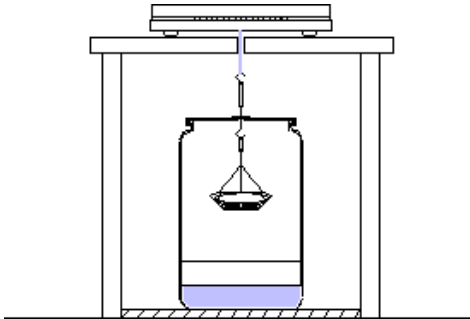
The method, based on ordinary glass jars with a modified lid, has the advantage of allowing the sample to be weighed while remaining in the desired climate. The method also facilitates quick step-changes in RH as the lid with the sample can be quickly moved from one jar to another.

## An experimentally simple method for measuring sorption isotherms

Lars Wadsö, Kaisa Svennberg & Ann Dueck (2004)

The paper presents a gravimetric method for determination of sorption isotherms based on conventional food preserve jars using aqueous salt solutions as humidity generator within the jar. The set-up is shown in Fig. II.

When a sorption isotherm is determined, the equilibrium criteria used is one important aspect to consider. For many materials the moisture uptake or release close to equilibrium is very slow, making it difficult to determine the true equilibrium. In this paper, an attempt is made to define an equilibrium criterion taking into account the moisture capacity and the size of the sample.



*Figure II. The experimental set-up of the method*

The method has two major drawbacks; the small sample size and the unknown and uncontrolled air velocity inside the jar. The latter making it difficult to estimate the surface mass transfer coefficient accurately. The method is presented in detail in the appended paper II (Wadsö, Svennberg et al. 2004). Saturated and unsaturated salt solutions have been used as humidity generators in my experimental work (Greenspan 1977; Nyqvist 1983; Chirife and Resnik 1984; Clarke and Glew 1985)

Sorption isotherms for indoor materials have also been determined using a sorption balance (DVS 1000, Surface measurements Systems, London, UK). This type of instrument has an upper limit of the sample mass of 100  $\mu\text{g}$  and is mainly used for studies of pharmaceutical materials (Chan, Clark et al. 2004), but it has also been used to determine sorption isotherms for other materials. In the present measurements the samples were exposed to an initial drying and then to following constant RH steps 0-10-20...80-90-95% RH and back again.

A weight change of less than 0.002% per minute was used as the equilibrium criterion at each RH level before proceeding to the next RH level. The sorption balance method is described in the appended paper IV (Svennberg and Wadsö, *submitted*).

The vapor resistance for thick materials such as, polyether foam, was determined using the cup method according to EN ISO 12572:2001 in two intervals of RH, i.e. 75-49% RH and 33-49% RH. The 75% RH was generated by using saturated NaCl-solution of and the 33% RH inside the cup by using a saturated MgCl<sub>2</sub>-solution.

The large uncertain interior resistances of the upright cup method, together with problems to fasten thin samples in the traditional cups, were the reasons to develop a modified inverted cup-method specially designed for thin, light and highly permeable materials such as textiles and paper. The method is based on standard laboratory crimp cap vials and uses saturated salt solutions in combination with vapor permeable membranes as humidity generator inside the vials. The modified cup-method was presented by Svennberg and Wadsö (2003).

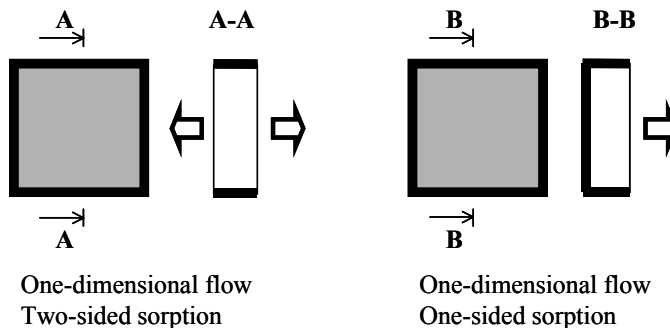
When the mass change, from the step-response measurements made in the sorption balance mentioned earlier, is plotted against the square root of time the diffusivity,  $D$ , can be evaluated using an evaluation method based on Crank (1975). The method is presented in detail by Anderberg (2004).

When performing sorption experiments on solid materials, attention should be paid to the method used to seal the edges. The choice of edge sealing systems is discussed in the appended paper III (Svennberg and Segerholm 2006). The masking effect of the edge sealing should also be considered and corrected for (Claesson, Hagentoft et al. 1994). In my experimental work, a beeswax/paraffin mixture, self-molding Parafilm and aluminum tape have been used. The choice of edge sealing system was mainly made with vapor tightness, hygroscopicity and workability in mind.

## Performance of Edge Sealing Systems Used in Moisture Transport Experiments

Kaisa Svennberg & Ingemar Segerholm (2006)

Edge sealing is often used to assure one-dimensional moisture flow and a defined exposure area in various types of moisture transport experiments. This paper deals with the overall performance of a number of edge sealing systems – including a wax-paraffin mix, epoxy adhesive, silicone and different tapes and films. The overall performance of the sealing systems includes vapor permeability and hygroscopicity, workability, thermal durability, flexibility, adhesion and risk of hydrophobation of the sample. The moisture-related properties are determined gravimetrically with the cup method and the JAR-method - a sorption method. The other properties are examined visually and qualitatively. Each of the properties of the edge sealing systems is rated using a graded rating from inadequate to excellent and the overall performance is an assessment of all the single properties. This comparative study shows that the best overall performance among the studied edge sealing systems were seen in the tapes and films. The mixtures have less good performance regarding workability and also demonstrate a higher risk of hydrophobation. The advantages as well as the disadvantages of each system are discussed together with some recommendations on usage.



*Figure III. Applications of edge sealants in sorption experiments.*

## 3.2 Climatic chamber measurements

The climatic chamber measurements were performed in a free standing well insulated climatic chamber previously used for passive solar experiments in Kgs. Lyngby, Denmark and in collaboration with the Technical University of Denmark. The climatic chamber has an air and moisture tight test room, with an area of 13.8 m<sup>2</sup> and a volume of 38.0 m<sup>3</sup>. By subjecting the room to controlled moisture variations, the moisture buffering effect of the materials in the climatic chamber could be assessed as the reduction of the RH variations compared to the empty chamber. The idea was to mimic the exposure of moisture variations to interior surface materials in a common indoor climate, but in a controlled way. The moisture production was controlled,  $\pm 33\text{g (H}_2\text{O)/h}$ , and the resulting RH variation within the test cell was registered.

The indoor humidification, representing the moisture production of an inhabited room, was provided by evaporation of moisture from a reservoir of water heated by an electric coil. Humidity was withdrawn from the air by a dehumidifier, draining into the same reservoir. The drying represents the removal of humidity from the room that would normally take place by ventilation. The climatic chamber measurements are described in detail in the appended paper VII (Svennberg, Hedegaard et al. 2004). The moisture uptake in a chair seat was investigated as a small part of the climatic chamber experiments. This were done by using small RH and temperature sensors that were placed at different depths in a chair seat subjected to the climate variations of the chamber described above. This study is presented in the appended papers V (Svennberg, Claesson et al. submitted) and VII (Svennberg, Hedegaard et al. 2004).

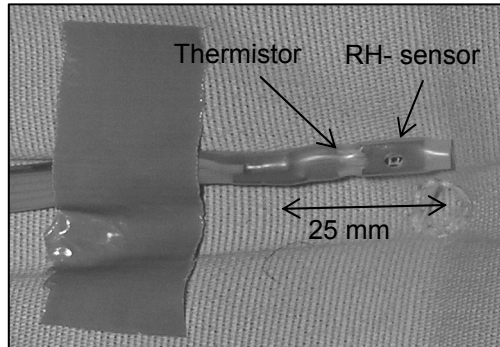
## 3.3 Field-measurements

In a field-study, two beds in two bedrooms in the same house, situated on the west-coast of Sweden, were used for measurement of diurnal temperature and RH variations.

The two bedrooms were placed on the second floor and have the same orientation. The basic furniture and the quantity of moisture buffering materials were the same in both rooms, only the bed type differed; one had a homogenous polyether foam mattress and the other was a multilayered bed with a spring and overlay mattress.

The measurements were carried out using small combined RH and temperature sensors. Each sensor consisted of a commercially available

RH sensor (Honeywell HI-3610) with an un-calibrated accuracy of 5% and a commercial precision resistance-temperature matched thermistor with a temperature accuracy of 0.2 K. The two sensors were combined by a rigid shrink tubing (with a slit in) into a small and durable sensor, see Fig. 6.



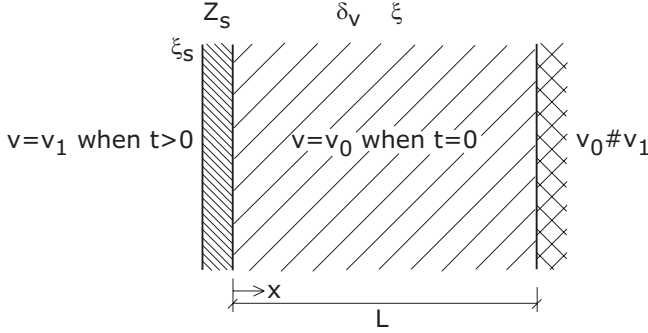
**Figure 6.** *The combined temperature and RH sensor mounted on the mattress with duct tape. Note the small slit in the shrink tube at the location of the RH sensor.*

### 3.4 Step-response model

A common approach is to assume that surface materials in the indoor environment have a surface layer that can be represented with only a surface moisture resistance. This assumption makes the moisture response to a step-change in the RH analogous to the thermal case. Luikov (1968) presents an analytical solution to the step-response in the thermal case and this has been used for hygric step-response calculations as well (Harderup 1983; Svennberg and Harderup 2002). However, the assumption with only a surface resistance and no capacity at the surface is not valid in the hygric case for several materials present indoors for, e.g., textiles and upholstery. Laboratory measurements (Svennberg and Harderup 2002) on gypsum wallboard painted with a paint system including a glass fiber backing also shows that the paint system itself has a noticeable moisture capacity. Similar results for paint on gypsum plaster are reported by (Goossens 2003). Within this project, an analytical step-response model for materials with a surface layer including both resistance and capacity has been developed. The approach can be seen as a further development of Luikov's analytical response model for step-changes.

The problem is considered to be a one-dimensional problem with a semi-infinite slab. The surface layer has a negligible thickness and therefore the

surface moisture resistance,  $Z_s$ , and the surface moisture capacity,  $\xi_s$ , are considered to be on the surface of the slab at  $x = 0$ . The slab has a vapor permeability,  $\delta_v$ , a moisture capacity,  $\xi$ , and a thickness,  $L$ . The surface mass transfer resistance due to a stagnate boundary air layer at the surface of the system is included in the surface moisture resistance,  $Z_s$ . Fig. 7 shows the basic geometry and the material parameters associated with the problem.



**Figure 7.** The basic geometry and the material parameters associated with an one dimensional step-response for a slab with a surface layer including both a resistance,  $Z_s$ , and a moisture capacity,  $\xi_s$ .

The vapor content  $v(x, t)$  shall satisfy the diffusion equation. The initial vapor content for the step-response solution is  $v_{in}$ :

$$\frac{1}{D_v} \cdot \frac{\partial v}{\partial t} = \frac{\partial^2 v}{\partial x^2}, \quad v(x) = \begin{cases} v_0 & t \leq 0 \\ v_1 & t > 0 \end{cases}, \quad 0 < x < L. \quad (3)$$

Here,  $D_v = \frac{\delta_v \cdot v_s(T)}{\xi}$  is the diffusivity. The moisture flux is zero at the

boundary  $x = L$ . There is a surface resistance  $Z_s$  and a thin layer that has the moisture capacity  $\xi_s$  at the boundary  $x = 0$ . The moisture fluxes from the unit air vapor content over the surface resistance, from the slab to the right, causes a vapor content change in the thin slab. We have the following boundary conditions:

$$\frac{\partial v}{\partial x} = 0, \quad x = L \quad (4)$$

$$\xi_s \cdot \frac{\partial}{\partial t} [v(0, t)] = \frac{v_1 - v(0, t)}{Z_s} + \delta_v \cdot \frac{\partial v}{\partial x} \Big|_{x=0} \quad (5)$$

Multiplying Eq.5 by  $Z_s$  gives

$$t_0 \cdot \frac{\partial}{\partial t} [v(0,t)] = v_1 - v(0,t) + L_0 \cdot \frac{\partial v}{\partial x}, \quad x = 0 \quad (6)$$

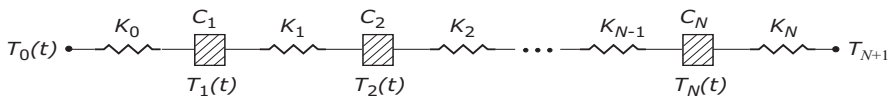
The boundary condition then involves a time  $t_0 = \xi_s \cdot Z_s$ , which is the decline time for the textile against air without flux from the underlying material. It also involves a length  $L_0 = Z_s \cdot \delta_v$ , which is a measure of the surface resistance  $Z_s$ .

The basic step response problem in Eq. 6 may be solved with a Fourier series expansion. The series converges very rapidly except for small times; an alternative solution is then used based on Laplace transformation. The complete solution is implemented in Mathcad, a computer algebra system, giving a five digit accuracy.

The model was also developed to fit ramp variations in the ambient relative humidity, and was used in the calculations in Paper V (Svennberg, Claesson et al. *submitted*)

### 3.5 One-dimensional dynamic network model

In connection to the field measurements in beds a basic mathematical simulation model to calculate the transient temperature and vapor content response for different bed systems was developed. The model is made up of two one-dimensional networks, representing two systems of coupled ordinary differential equations (ODE) – one for the thermal calculations and one for the hygric calculations. Constant material properties are used and the temperature dependence for the moisture parameters is neglected. This means that the two systems are uncoupled from each other. Each bed system is divided into a suitable number of nodes – discretization. The mattress geometry was simplified by disregarding all casing materials, and the compression of the mattress materials during use.



**Figure 8.** The thermal network for the general case, having  $N$  nodes.



Figure 8 shows a thermal network with  $N$  nodes for the general case. Node  $n$  has the heat capacity  $C_n$  (J/K). In the calculations, a unit area ( $1 \text{ m}^2$ ) is considered in the horizontal plane perpendicular to the vertical heat and moisture flow processes. The thermal conductance between node  $n$  and  $n+1$  is  $K_n$  (W/K). The heat balance equations for the  $N$  nodes are

$$C_n \cdot \frac{dT_n}{dt} = K_{n-1} \cdot [T_{n-1}(t) - T_n(t)] + K_n \cdot [T_{n+1}(t) - T_n(t)], \quad n=1, 2, \dots, N \quad (7)$$

The equations together with the boundary conditions may be written in matrix form:

$$\mathbf{C} \cdot \frac{d}{dt}(\mathbf{T}) = \mathbf{K} \cdot \mathbf{T} + \mathbf{B}(t) \quad (8)$$

Here,  $\mathbf{T}$  is a column vector with the components  $T_n(t)$ . The  $N \cdot N$  matrix  $\mathbf{C}$  has the heat capacities  $C_n$  in the diagonal, while all non-diagonal elements are zero. The conductance matrix has the values  $-K_n - K_{n+1}$  ( $n=1, \dots, N$ ) in the diagonal, and  $K_2, \dots, K_N$  in the bidiagonals. The column vector  $\mathbf{B}(t)$  has  $B_1(t) = K_1 \cdot T_{b1}(t)$  and  $B_N(t) = K_{N+1} \cdot T_{bN}(t)$ , while the remaining components are zero.

The solution is obtained with the standard method involving eigenvalues and eigenvectors to the matrix  $\mathbf{C}^{-1} \cdot \mathbf{K}$ . The eigenvalues are obtained from the equation

$$\det(\lambda \mathbf{I} + \mathbf{C}^{-1} \mathbf{K}) = 0 \quad \rightarrow \quad \lambda = \lambda_1, \dots, \lambda_N \quad (9)$$

Here,  $\mathbf{I}$  is the unit matrix. Let  $\mathbf{U}$  be the matrix with the eigenvectors as columns:

$$\mathbf{C}^{-1} \mathbf{K} \cdot \mathbf{U}^{(n)} = \lambda_n \cdot \mathbf{U}^{(n)}, \quad n=1, 2, \dots, N \quad (10)$$

The solution in matrix form is now

$$\mathbf{T}(t) = \mathbf{U} \mathbf{E}(t) \mathbf{U}^{-1} \mathbf{T}(0) + \int_0^t \mathbf{U} \mathbf{E}(t-t') \mathbf{U}^{-1} \mathbf{C}^{-1} \mathbf{B}(t') dt' \quad (11)$$

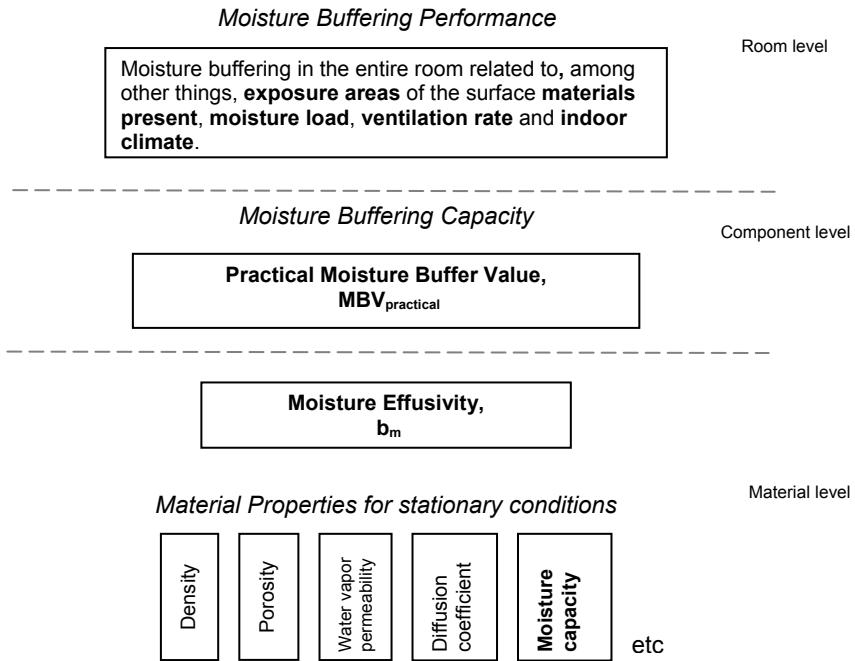
Here,  $\mathbf{U}^{-1}$  is the inverse matrix to the eigenvector matrix  $\mathbf{U}$ . The matrix  $\mathbf{E}(t)$  has the exponentials  $\exp(-\lambda_n \cdot t)$  in the diagonal, while all non-diagonal elements are zero. The first term involves multiplication of matrices and the exponentials in time. The second part involves multiplication of matrices and an integration over  $0 \leq t' \leq t$  of the exponentials  $\exp(-\lambda_n \cdot (t-t'))$  multiplied by the boundary temperatures  $T_{b1}(t')$  and  $T_{bN}(t')$ . This solution in matrix form is readily calculated with a mathematical program such as Mathcad.

The moisture balance equations for calculation of the vapor content,  $v$ , in the general case can be derived by analogy from the heat balance equation (Eq. 7) above. The temperature  $T$  will then be substituted with the vapor content,  $v$ , and the thermal conductance  $K_n$  and heat capacity  $C_n$  with the corresponding vapor conductance  $K_{v,n}$  and moisture capacity  $C_{v,n}$ .

# 4 Main results

## 4.1 The definition scheme for moisture buffering

Moisture buffering can be defined for different time scales, from short diurnal variations to seasonal variations. It can also be defined for different spatial levels. However, there is still no commonly approved set of definitions for moisture buffering that covers the complete range from material level to room level.



**Figure 9.** *Definition scheme for the moisture buffering phenomena in the indoor environment. The Moisture Buffering Performance refers to the room level including both building materials and furnishing materials within the room. The Moisture Buffering Capacity is connected with the component level – the simplest component being a homogeneous material with a stagnant air layer at the surface. The moisture capacity is one of the material properties considered in the material level.*

The definition scheme (Fig. 9) that I propose, includes three levels starting with the traditional moisture properties for a *material* including the moisture

capacity. The moisture capacity is defined as the slope ( $dw/d\varphi$ ) of the sorption isotherm, see Fig 2. The moisture transport coefficient will also play an important role and need to be taken into account as well. Other material properties are also needed, such as the density and surface moisture transfer resistance (Svennberg 2003). In this group the combined definitions made up only by material properties are also found, one example being the moisture effusivity,  $b_m$ .

The next level in the definition scheme is the ‘moisture buffering capacity’. This should to be seen as a parameter for the *component* level, such as painted wood or a bed with several layers. On this level of the definition scheme, the time period for the moisture variations needs to be taken into account. There is at present, no consensus around one single parameter to express the moisture buffering capacity, and there are several theoretical and experimental definitions in use. Two examples are the practical moisture buffer value,  $MBV_{\text{practical}}$ , and the Moisture Sorption Efficiency.

The third level is the complete *room* and I suggest that the parameter discussed for whole rooms should describe the ‘moisture buffering performance’ of the room. The parameter used should preferably be related to the parameter used for the moisture buffering capacity of the materials and their exposed area, respectively. For a more complete description of the moisture buffering performance of the room it is necessary to include the effect of ventilation and heating as well as the varying microclimate behind curtains and large furniture. The Hygric Inertia concept,  $I_h$ , is a concept relating to moisture buffering performance. It takes into account the  $MBV_{\text{practical}}$  and the area for materials with a two-dimensional exposure, e.g., wall, and ceiling materials. The impact of furniture having a three dimensional exposure area, the buffering effect is based on mass.

In the transition from one level on to another in the definition scheme some information is lost due to simplification and adjustments to fit the model and/or definition used. On the other hand, new information concerning the moisture buffering phenomena is added going from one low step to a high, e.g., in the step between moisture buffering capacity and moisture buffering performance, the exposed area in relation to the total room volume is added.

## 4.2 Surface materials of the indoor environment

Even though most surface materials present in the indoor environment are well known, both information on exposure areas of each type of material and material properties are lacking. An attempt to assess the exposure areas in a

time efficient way is presented together with sorption isotherms for textile materials commonly found in the indoor environment.

#### 4.2.1 Exposure of surface materials

In a small study, an inventory regarding exposed surface materials was made in 16 rooms in six apartments in two buildings in Växjö in the south of Sweden. The total exposed area was 1115 m<sup>2</sup>. The inventory used a specially designed inventory questionnaire, where each type of furniture was listed together with typical surface materials. The exposed area was assessed trying to estimate the true exposure. For example, for a sofa placed tight against the wall the surface at the back was disregarded. For curtains the thickness was used to assess an effective exposure. The results are shown in Table I. Approximately 30 minutes was used to assess each room.

**Table I. Results from the inventory study in Växjö.**

Material	%
Wood - untreated	0.5
Wood - surface treated	14.6
Synthetic flooring	8.3
Wallpaper	33.4
Painted surfaces	20.8
Textile carpets	4.2
Textile furnishings	18.2

Today there is a lack of knowledge of the exposure of surface materials in the indoor environment. This small inventory showed that if a questionnaire was used, it was possible to get a good idea of the exposure of different surface materials in a reasonable time.

#### 4.2.2 Sorption isotherms for textile materials of the indoor environment

Sorption isotherms were determined using a sorption balance (DVS 1000, Surface measurements Systems, London, UK) for two upholstery foams, a wool batting and nine textile fabrics, all typical for the Scandinavian indoor environment. The experiment and results are presented in detail in Paper IV (Svennberg and Wadsö *submitted*).

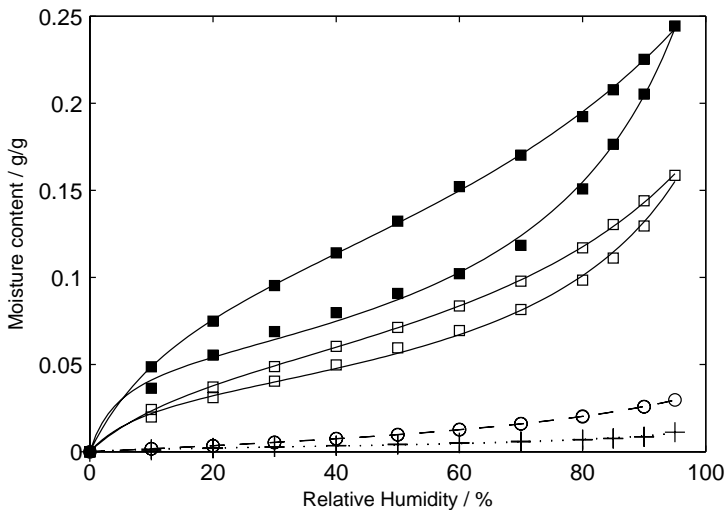
The sorption isotherms were plotted with the equilibrium moisture content for absorption and desorption,  $u_{\text{abs}}$  and  $u_{\text{des}}$ , for each RH respectively. The Hailwood-Horrobin sorption isotherm equation (Hailwood and Horrobin 1946), Eq. 12, was applied both for absorption and desorption:

$$u = \frac{\varphi}{A + B \cdot \varphi - C \cdot \varphi^2} \quad (12)$$

$A$ ,  $B$  and  $C$  are fitting parameters for the Hailwood-Horrobin sorption isotherm equation. We found good agreement for all the tested materials, and that the Hailwood-Horrobin equation is a convenient equation for fitting sorption isotherms of textiles.

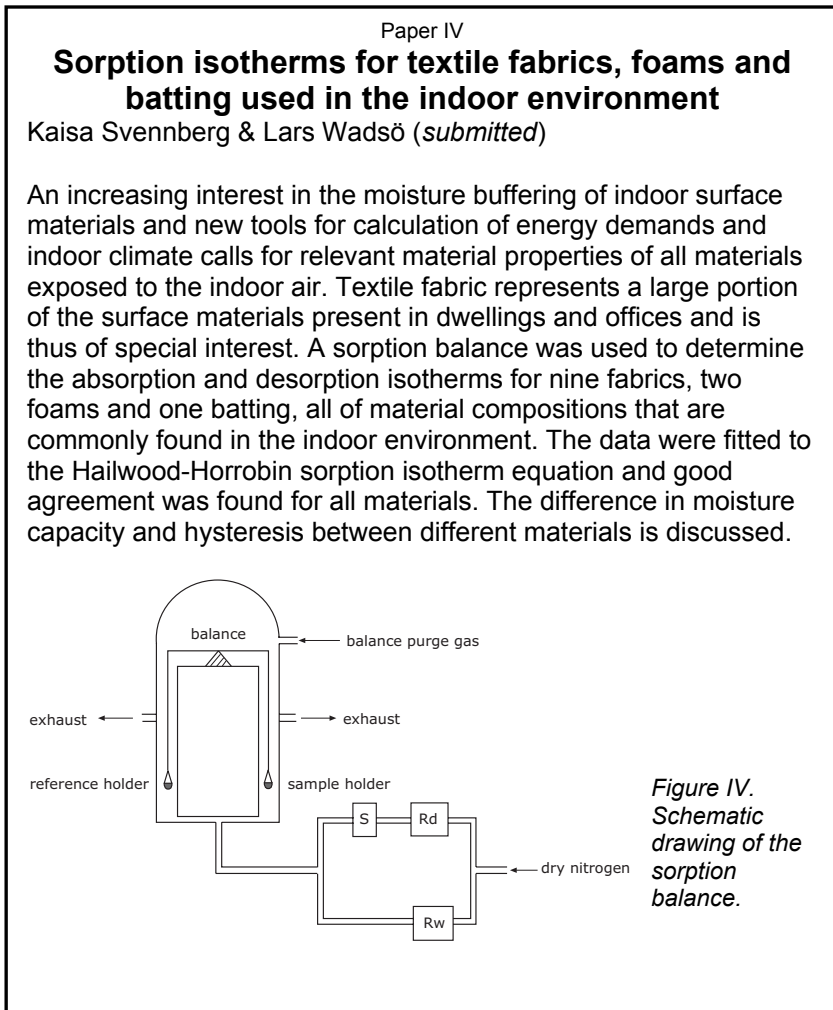
The two foams, regular polyether foam and viscoelastic polyether foam, have significantly different sorption behavior. The regular polyether foam has a low moisture uptake and shows no hysteresis. It is also the only material in this study that does not have a sigmoid sorption isotherm curve as it is linear up to 25% RH. The highly viscoelastic polyether foam shows a higher moisture uptake compared to the regular polyether foam and a small but noticeable hysteresis effect.

The cotton-based and synthetic textiles for soft furnishing show similar sorption isotherms with hysteresis, Fig 10, with the exception of the 100% polyester fabric that has a low moisture uptake and no hysteresis.



**Figure 10.** The sorption isotherms for: (■) 100% wool fabric, (□) 100% cotton bedding fabric, (○) 100% polyester fabric, and (+) regular polyether foam.

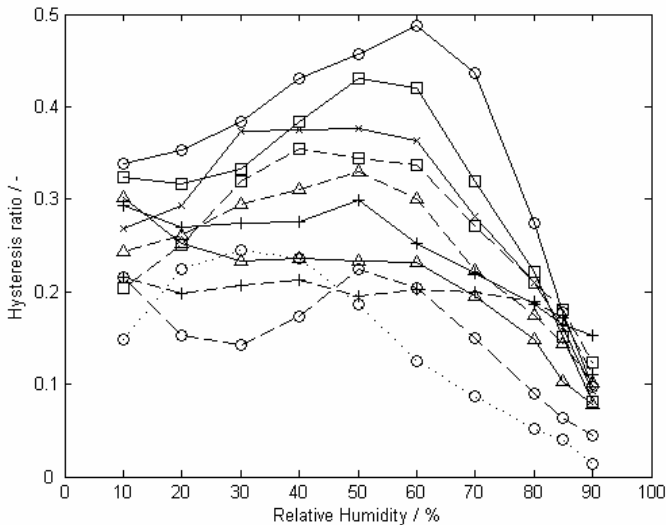
The cotton-based and the synthetic fabrics have, as expected, a lower moisture uptake than the wool based fabrics. The highest equilibrium moisture content at high RH was found for the 50% viscose-50% wool fabric.



The hysteresis ratio  $H$  between absorption and desorption isotherms was evaluated by Eq. 13 (Okubayashi, Griesser et al. 2004):

$$H = \frac{u_{des} - u_{abs}}{u_{abs}} \quad (13)$$

The hysteresis ratios for the majority of the tested materials are shown in Fig. 11.



**Figure 11.** *The hysteresis plotted against RH for: the wool based materials - solid lines [(○) felted wool fabric, (□) plain wool fabric, (+) viscose-wool fabric and (△) polyamide-wool fabric], cotton based materials - dashed lines [(○) cotton-flax fabric, (□) cotton curtain fabric, (+) cotton bedding fabric and (△) cotton-polyester fabric] and synthetic foam - dotted line [(○) viscoelastic polyether foam].*

A complication when modeling sorption effects with materials showing hysteresis is that the effective moisture capacity is considerably smaller than either of the absorption or desorption curves would suggest on their own. Sinusoidal RH variations will make the RH-moisture content trace a loop within the absorption-desorption boundaries.

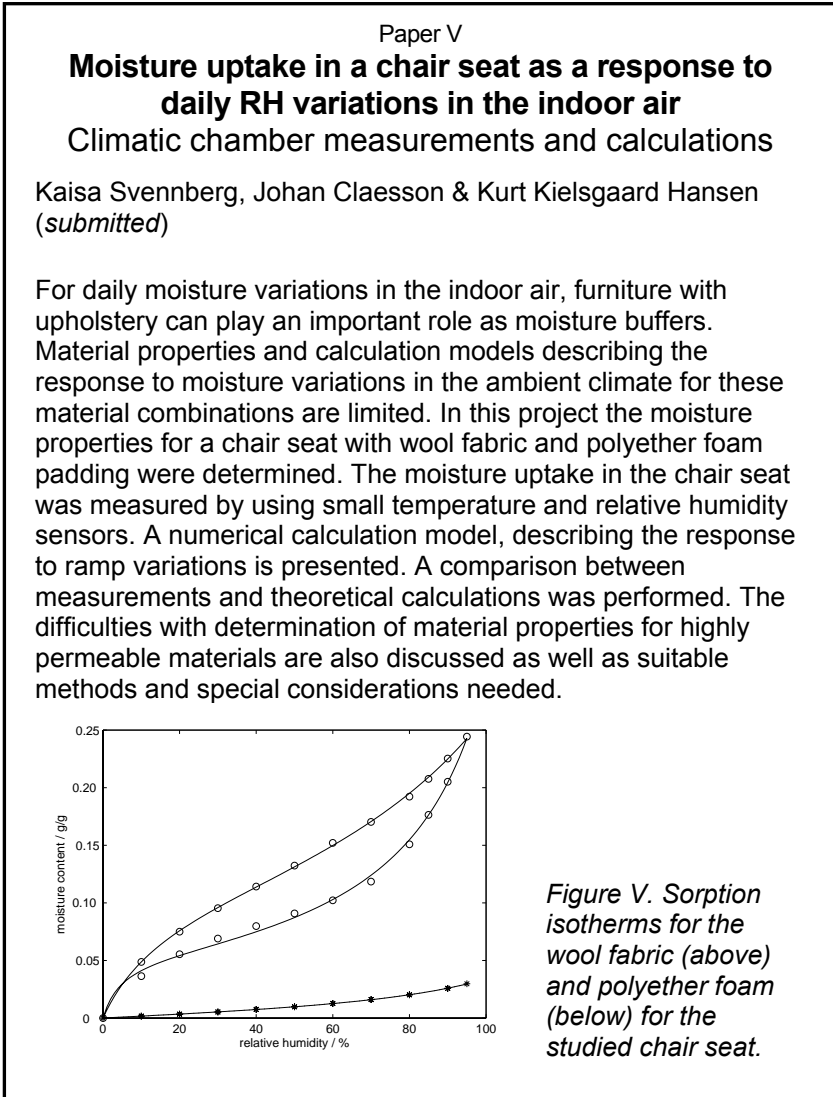
### 4.3 Upholstered furniture – two examples of material systems

Upholstered furniture are of interest in connection to indoor moisture buffering for two reasons. Firstly, they have significant moisture buffering capacity. Secondly, the resulting microclimate in such furniture may create suitable habitats for house dust mites. Within this project two types of upholstered furniture have been studied, an office chair and two types of beds.



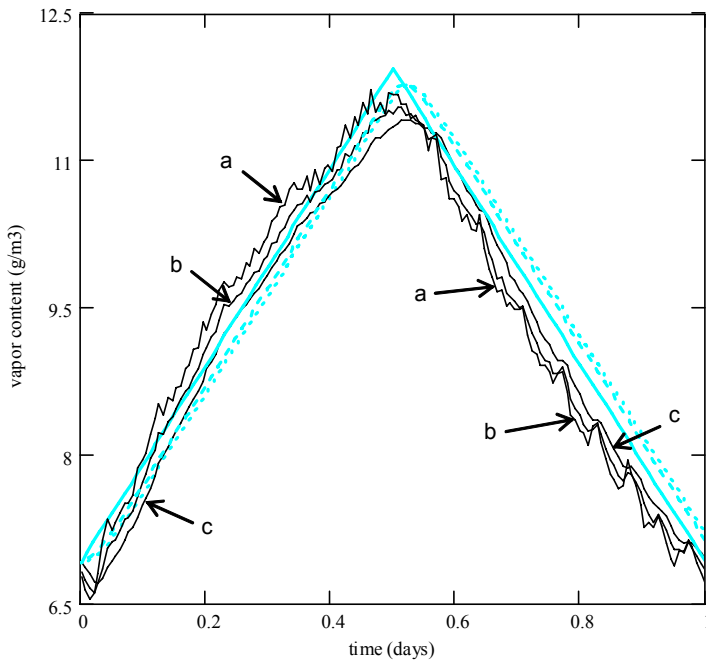
### 4.3.1 Chair

A chair seat of an ordinary office chair with a wool fabric surface and a padding of regular polyether foam were subjected to diurnal moisture variations in connection to the climatic chamber measurements performed in collaboration with the Technical University of Denmark. The results are presented in Paper V (Svennberg, Claesson et al. *submitted*)



The chair seat was equipped with three small RH and temperature sensors at different depths. The chair seat was subjected to 12 h increasing RH and 12 h decreasing RH in each cycle.

The measurement results were compared with calculations, using an analytical solution for moisture response to ramp loads, developed from the analytical solution for step-response including a surface layer with moisture capacity and vapor resistance described in section 3.4. Material properties determined within the project were used as input data. A comparison between calculations and measurements is shown in Fig. 12.



**Figure 12.** Comparison between the measured vapor content in the chair seat during the climatic chamber experiments thin solid lines (a – the top surface, b - under the fabric, c – under the polyether foam) and the analytical solution (thick grey lines: solid – the top surface, dashed - under the fabric, dotted – under the polyether foam).

The analytical solution uses an ideal triangular variation for the ambient climate and is therefore not capable of taking the small fluctuations caused by the climatic system into account. Still, the analytical solution provides a good representation of the moisture uptake in the chair seat. An additional internal resistance in the analytical solution, as well as using more accurate boundary

conditions, would improve the already satisfactory agreement between measurement and theoretical calculations even further.

### 4.3.2 Bed

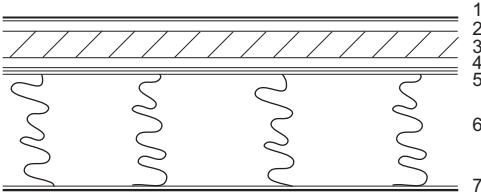
The microclimatic conditions in two bed systems, one with a homogeneous polyether foam mattress and one with a multilayered spring mattress, were studied by field measurements and simulations. The results are presented in Paper VI (Svennberg, Claesson et al. *submitted*)

Paper VI

**Microclimates in beds –  
field measurements and simulation of temperature  
and moisture conditions in two bed systems**

Kaisa Svennberg, Johan Claesson & Lars Wadsö (*submitted*)

House dust mites are a common source of allergy in, e.g., Scandinavia, where their major habitat is in beds where they feed on skin scales. There have been attempts to alter the microclimatic conditions in beds to reduce the house dust mite occurrence. The microclimatic conditions in beds have also been studied earlier both in field measurements and by modeling but there is still a lack of knowledge on how the hygrothermal material properties of the mattresses and bedding affect the environmental conditions for the house dust mites. This paper presents diurnal temperature and RH variations in two mattress and beddings under normal use measured for two different bed systems, one homogenous and one multi-layered mattress. The results from the field study are compared with the results from a simulation model for the hygrothermal conditions in each bed. This study is a part of a multi-disciplinary project aimed at finding technical solutions for reduction of house dust mites in bedrooms by environmental control.



The diagram illustrates the cross-section of a multi-layered mattress, labeled with numbers 1 through 7. Layer 1 is the top surface. Layer 2 is a thin layer below the surface. Layer 3 is a thicker layer with diagonal hatching. Layer 4 is another thin layer. Layer 5 is a thin layer containing four vertical springs. Layer 6 is a thin layer below the springs. Layer 7 is the bottom surface.

1  
2  
3  
4  
5  
6  
7

*Figure VI. The structure of the multi-layered mattress*

The temperatures for the bed surfaces are essentially the same for bed A and B and show good agreement with previous field measurements (Cunningham 1998). The temperature on the surface of the beds during occupancy is approximately 35°C and correlates with the human skin temperature (Hokoi et al. 2004).

The temperatures under the mattress are lower for bed A compared to bed B, ~20 °C compared to ~30 °C, during occupancy. This was expected, as the thickness of the mattress in bed B is only 58% of the mattress thickness in Bed A, and the spring mattress in Bed A provides an extra thermal insulation.

The effect of making the bed and putting the bed cover on was seen in temperature measurements. The morning after the second sleeping period bed B was not made, and followed the cooling pattern of bed A, reaching room temperature twice as fast when the cover was on. (Bed A was never made during the measuring period).

The results from the RH measurements are hard to interpret, mainly because of the large fluctuations. These fluctuations are most probably due to the movement of the sleeping persons, giving a strong fluctuation in both temperature and moisture production in each measurement point. Both beds show RH lower than expected, this is most evident for Bed B that barely reaches 58% RH which is believed to be the lowest critical RH for HDM growth (Arlan, Bernstein et al. 1982).

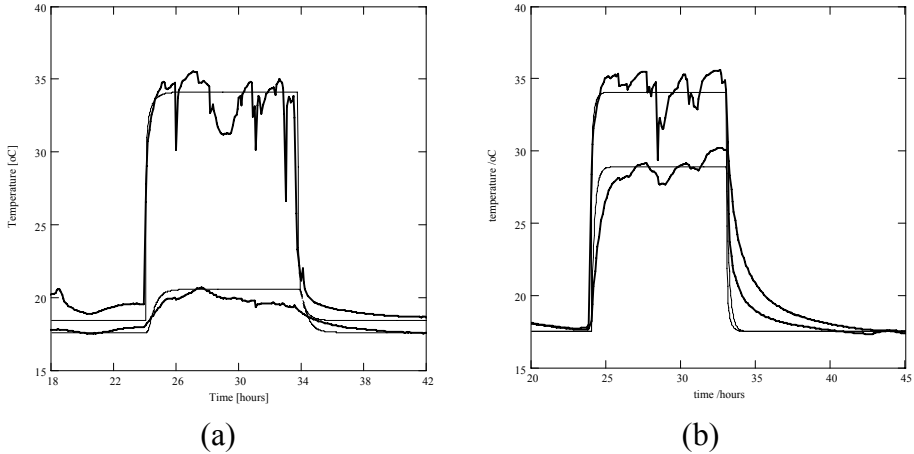
The vapor content variations during the sleeping periods at the surface of the mattress are similar for both beds. The vapor content results for bed A suggest moisture redistribution during day-time that is not found for bed B where the vapor content for both top and bottom of the mattress is approaching the room vapor conditions during day-time. Also for the vapor content the impact of not making the bed can be seen for bed B. The bed then approaches the room vapor conditions quicker when left unmade and without bed cover.

A one-dimensional simulation model as described in section 3.5 was used to make calculations of the microclimatic conditions in the beds using basic material properties. The material properties were obtained both from experiments and literature. A modification of the general case for the thermal network had to be made in order to take into account the heat radiation and convection in the air gap of the spring mattress.

The comparison between calculations and measurements are made for the most typical sleeping period. After the sleeping period none of the beds were made and in the calculation model the 'upper' bedding made up of duvet,

pillow and bedcover is disregarded. This limitation makes the calculation model useful only as a comparative tool.

Figures 13 a and b show the calculated temperatures in comparison to measured for bed A and B respectively. For bed B the deviation in time scale for the cooling when the bed was vacated is more accentuated than in bed A. The longer time scales seen in the measurements are possibly the result of the extra thermal capacity represented, by the bedding neglected in the model.

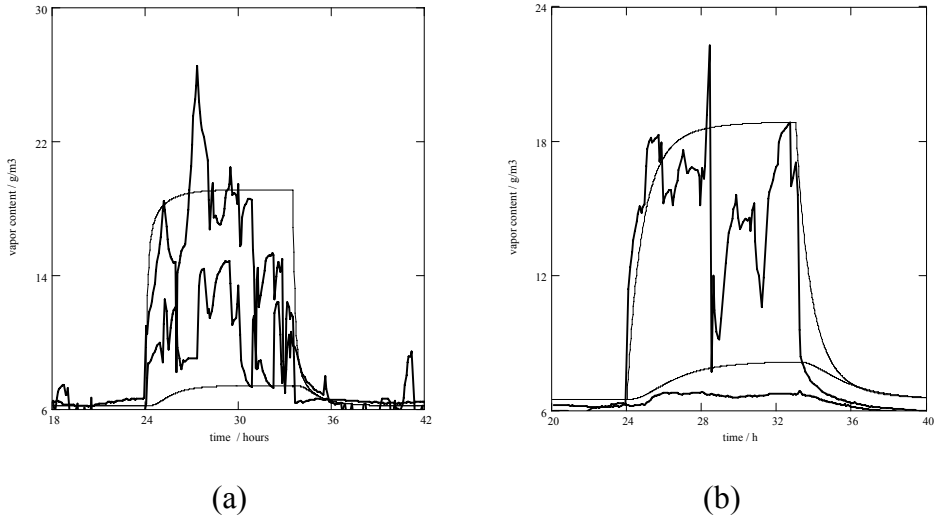


**Figure 13.** *Thermal conditions for bed A (a) and B (b) measured and simulated for both bed systems. Measured temperatures show fluctuations while the simulated ones are more constant. The top lines represent the top of the mattress and the bottom line the position under the mattress.*

The fluctuations seen in the measurements for both bed A and B are due to the movement of the sleeping person. A solution will be to measure the temperature in several points throughout each level of the bed. However, this might affect the comfort of the user and secondarily have an impact on the sleeping pattern. Therefore, great care should be taken to avoid discomfort for the sleepers when such a measurement is performed.

In Figs. 14 a and b the comparison between calculated vapor content and measured is shown. As in the thermal case does the measurements for the homogenous bed A show better agreement with the calculations than bed B. The calculations underestimate the vapor content under the mattress and under the bed for bed A, this might be a result of plastic boxes stored in the space under bed A. On the other hand, the calculation for bed B overestimates the vapor content in the same positions in bed A. This may be due to simplifications made for the multilayered bed, where the casing materials for

the spring mattress and the overlay mattress are omitted and perfect contact between the layers are assumed. The time scales for the calculation for bed B are longer than for the measured. The hygric timescales for both bed systems, are considerably longer than the thermal cases, and do not reach quasi-equilibrium conditions until approximately half-way into the sleeping period.



**Figure 14.** *Hygric conditions for bed A (a) and B (b) measured and simulated for both bed systems. Measured vapor contents show fluctuations and the simulated ones are more constant. The top lines represent the top of the mattress the bottom lines the position under the mattress*

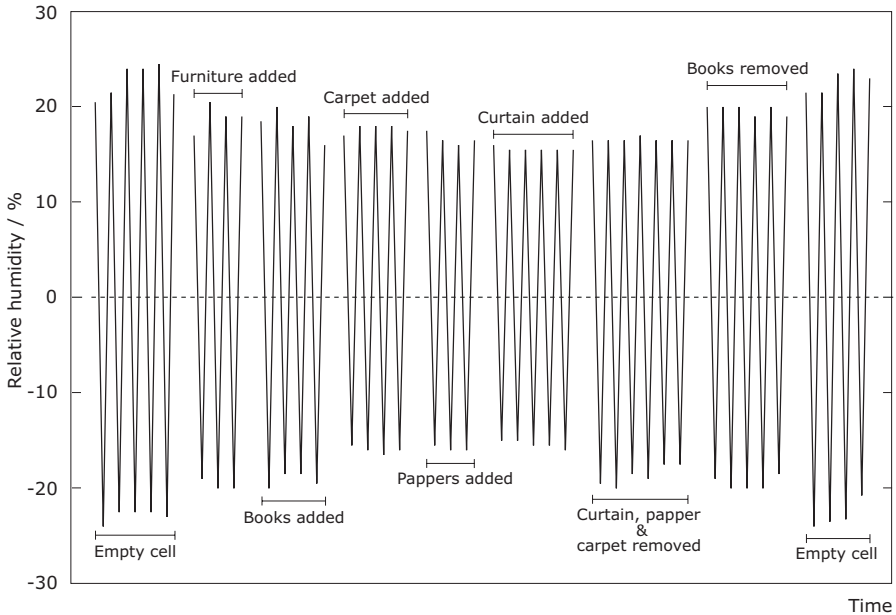
The basic simulation model provided a good agreement in the thermal case, but merely a reasonable agreement for the hygric case. However, this will probably be improved if the temperature and vapor content will be calculated in a coupled system of equations. This could be done using general numerical ODE solvers, but this calls for more refined material properties that take into account both the temperature and the moisture dependence. The model would also be improved, if the boundary condition in the hygric calculations should be described as a vapor flux rather than a vapor content. This modification could be done within the frame work of the solution of the network model. The model should be seen as a first attempt to use actual material properties as input data.

At this point, it can be hard to find and determine isothermal material properties for these lightweight and compressible materials. If the complexity of the compression of the material also should be taken into consideration,

even more challenges lies ahead. More research regarding the hygrothermal material properties could provide a platform for a better understanding of the microclimatic variations in beds during use. Further investigations regarding the importance of sleeping patterns and individual moisture production needs to be done.

#### 4.4 Moisture buffering performance of a room

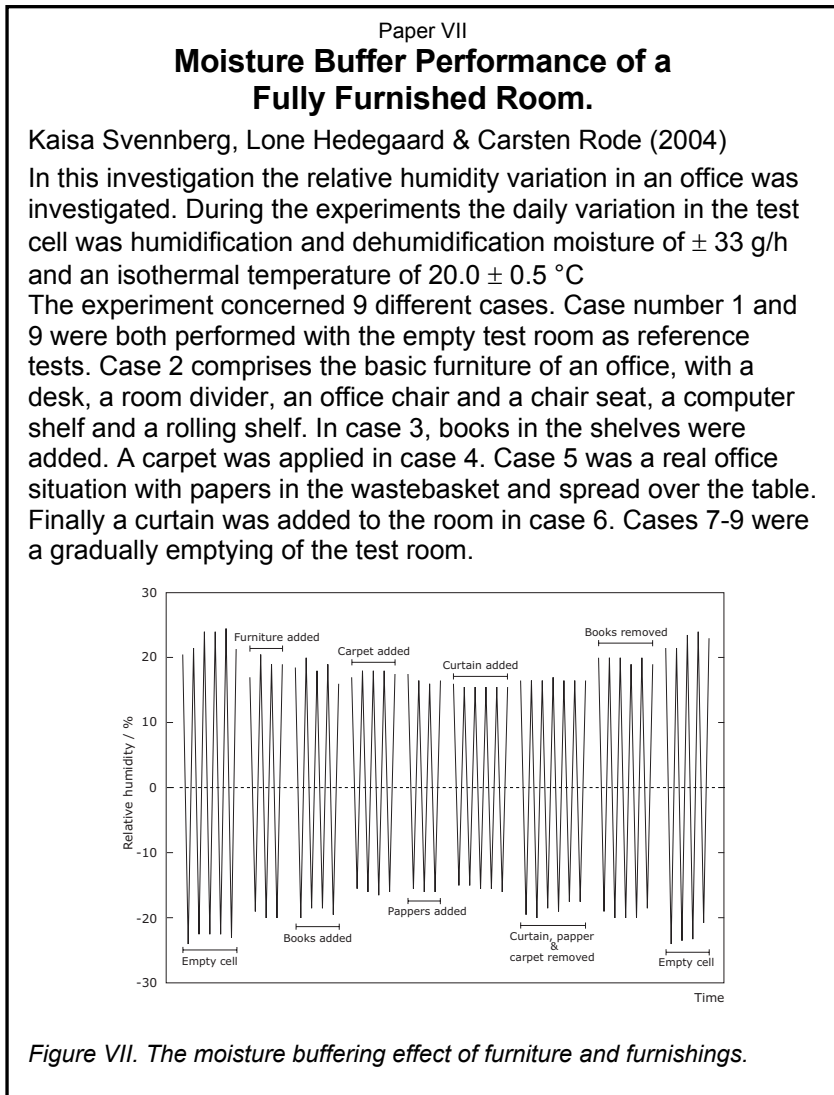
The ranking concept for a number of commonly used surface material was used by (Svennberg et al. 2004), Paper VII, as a basis for the experimental design of a room sized climatic chamber experiment. The furniture and furnishings were added to a moisture inert climatic chamber with a triangular diurnal cyclic moisture variation (12 h wetting and 12 h drying).



**Figure 15.** *The RH variations of the climatic chamber for each of nine test cases in the climatic chamber study. (Svennberg et al. 2004)*

The furniture and furnishing materials were placed in a climatic chamber in sequence from ‘coated’ materials to more ‘open’. The results show that the largest impact on the variations in relative humidity on room level was seen when the more open materials such as textiles and paper was introduced into the climatic chamber, Fig. 15.

The experiment shows that there is a difference in the moisture buffering performance between the fully furnished test room and the empty test room. The two cases have approximately the same average RH (55% and 57% RH), but the RH measurements of the fully furnished room show a smaller amplitude. The smaller amplitude the larger moisture buffering capacity in the surface materials if the ambient conditions are similar in the cases compared, as in these experiments.





For a one day variation, the fully furnished room has a maximum RH, which is 10% RH lower compared to the empty room. The daily minimum RH value for the fully furnished room is 5% RH higher compared to the empty room. Overall, this provides a less varying indoor climate in a fully furnished room. Comparing all the different cases, Fig. 15, it can be noted that the cases where lightweight organic materials, such as papers and textiles, are exposed, have the lowest variation in RH for these weekly sequences of daily variations.

The measured results of the indoor RH were compared to calculations of indoor humidity made in B-sim (Rode and Grau 2003). The simulation result for the empty room shows a variation between 26 and 88 % RH, while the simulations vary between 45 and 66% RH for the fully furnished room. One reason for the discrepancy between the measurements and the simulation is the uncertainty in the material properties used as input data for the simulation. The moisture capacity used did not take into account scanning curves between absorption and desorption, which is more likely to be true for cyclic variations, rather than the sorption isotherms based on equilibrium moisture content. Neglecting the scanning will lead to an overestimation of the moisture buffering effect.

## 5 Discussion

The proposed definition scheme provides a systematic basis for analyzing the moisture buffering phenomena in the indoor environment. The definition scheme can also be used to more clearly categorize definitions, concepts, models and laboratory methods used in the area. It will hopefully also enhance the understanding of the moisture buffering phenomena in the indoor environment, and the factors influencing it and thereby contribute to further advancement.

On the material level, there is still a lack of reliable material properties for many materials common in the indoor environment, especially water vapor permeability (or resistance) data for textiles. There is also a shortage of suitable test methods for thin and permeable materials. Therefore the results for the vapor permeabilities determined for the fabrics in the chair and the bed studies suffer from a large uncertainty. The error introduced, even by a small air layer, could be considerable for this type of materials.

When going from the material level to a component level, the resistance of the air layers should be included, but this introduces yet another problem since the ‘thickness’ of the air layer can be hard to assess, both in the experiments and real situations. This is mainly due to difficulties to measure the air velocity close to a surface without introducing disturbances.

The comparison between measurements and calculations on the upholstered furniture shows that it is possible to get reasonable predictions of the microclimatic conditions in these systems. But in order to achieve more accurate results a coupling between the thermal and hygric cases would be desired. This can only be done if temperature dependent moisture related material data is available, which is not presently the case for most materials used in upholstery. Bed materials are often highly compressible giving rise to an extra complication when choosing material properties. Taking the compressibility into account when determining the material properties, adds an extra challenge to the experimental set-up.

In moisture buffering calculations the impact of hysteresis is often overlooked. As a result thereof, the moisture buffering effect in the calculations will be overestimated. Also in this project was the effect of scanning curves for the various materials disregarded. One suggestion would be to develop a method to easily assess an ‘effective moisture capacity’ that gives a more realistic output for moisture buffering calculations. Moisture buffering of real rooms under use will include the influence of humans and their activities have a large

impact on the moisture conditions obtained. This is important to keep in mind, both in designing field measurements and when performing whole room or even whole building simulations. In the field measurement of the two bed systems, the most striking effect of humans was the uncertainty that the individual sleeping patterns introduced. This will be even more important when the bed model should be enlarged to cover also the upper bedding, such a duvet and pillow. First of all the field measurement must then be designed so that comparison of the sleepers' movement can be performed. Secondly, the movement of each sleeper must be described in such a way that it can be correlated to hygrothermal effects seen in the bed.

The measurements and calculations regarding the moisture buffering performance of a fully furnished room showed that furniture and furnishings have an impact on the moderation of the moisture variations of the indoor air. The calculation program used B-Sim, like most other hygrothermal calculation programs, did not have the possibility to take into account the real three-dimensional appearance of the furniture. Such a feature would be desirable. The two calculation tools developed within this project may be useful in the development such a feature. In order to obtain more accurate descriptions on the influence of furniture on moisture buffering and the air flow patterns realistic room conditions need to be further investigated.

Health aspects of moisture buffering are most evident in the diurnal moisture variations that take place in our beds. The bed study within this project shows that the design and material choices affect the hygrothermal conditions in the bed. This knowledge together with improved models and material data should make it possible to design bed systems with microclimatic conditions that are unfavorable to house dust mites and this in turn should lead to less mite infected beds with allergens and hopefully less problems for house dust mite allergic persons.

## 6 Conclusions

The conclusions from this Ph.D.-project are:

- Moisture buffering can be defined according to the proposed definition scheme on three spatial levels, material, component and room level. This definition scheme can be used to group concepts and definitions as well as laboratory methods and calculation tools.
- The moisture buffering does not only effect the moisture conditions of the indoor air but also the ‘moisture buffering’ materials. This is clearly seen in the microclimatic conditions of upholstered furniture such a chairs and beds.
- In fully furnished rooms a notable impact on the moisture conditions in rooms from furniture and furnishings is seen.
- Two calculation tools for furniture and furnishings including moisture capacity as well as vapor resistance for the surface layer were developed. These tools can be used in the further development of whole-building calculation models in order to handle not only traditional building materials, but also furniture and other furnishing materials.
- The health effects of moisture buffering are potentially most important in the bed case were the microclimatic conditions will have an impact on house dust mite density and allergy.

## 7 Future work

With the starting point in this PhD thesis and work done in the project I propose the following topics for future work:

- The small climatic chamber method based on glass jars, the JAR-method, could be developed further by connecting a small pump to the lid. This modification would allow a better control of the air velocity and the air flow pattern in the glass jars.
- The approach concerning the performance of the edge sealing systems should be discussed further. A set of experimental tests to assess relevant properties for edge sealing systems should be developed.
- The water vapor permeability of thin and permeable materials in the indoor environment, such as textiles and paper, needs to be determined. In order to do that in a physically correct way, the measurement method should be carefully considered. A comparative study using some typical materials of the indoor environment is desirable in order to find the most suitable methods. Such a study has already been performed for membranes used in functional rain clothes (McCullough et al. 2003).
- The dynamic effects of absorption, desorption, hysteresis and scanning curves for moisture buffering materials need to be further investigated. A simplified and practically approach of ‘effective moisture capacity’ would improve moisture buffering calculations as well as decrease the risk of introducing a new errors when taking moisture buffering into account.
- To improve the bed simulation models further, there is a need for temperature dependent material properties. If reliable material properties are present the use of a general numerical ODE solver would make it possible to couple the thermal and hygric calculation networks, a measure that would improve the accuracy of the bed model.
- The analytical step response model including a moisture capacity in the surface layer could be used in the analysis of painted surfaces. The understanding of moisture buffering in surface materials would then be enhanced.

- The definition scheme for moisture buffering needs to be implemented.
- A methodology to estimate the moisture buffering performance of a room needs to be established, and validated with well defined climatic chamber and field measurements.
- The climatic requirements for house dust mites and population development models need to be combined with models of microclimatic conditions in beds.
- New methods to handle the three-dimensional features of furniture in a room will be useful. The correlations between arrangement of furniture, exposure area of moisture buffering materials, room volume and air movements need to be investigated.
- A statistical valid inventory of exposure of moisture buffering materials in office and residential buildings in combination with indoor temperatures and relative humidities would be very useful.
- The impact of outdoor climate change due to global warming needs to be considered.

## Additional publications by the author

(not appended to this thesis)

### Licentiate Thesis

- 2003 Svennberg, K. “*Determination of Moisture Properties of Materials Exposed to the Indoor Air*”, Building Physics, Lund University

### Peer- reviewed conference papers

- 2006 Rode, C., Peuhkuri, R., Hansen, K.K., Time, B., Svennberg, K., Arfvidsson, J & Ojanen, T., “Moisture Buffer Value of Building Materials”, ASTM Symposium on Heat-Air-Moisture Transport: Measurements on Building Materials, April 23, 2006, Toronto, ON, Canada
- 2005 Svennberg, K. & Wadsö, L. “Measurement of microclimates in beds in relation to the climatic requirements of house dust mites”, 7th Symposium on Building Physics in the Nordic Countries, Reykjavik, The Icelandic Building Research Institute, Reykjavik.
- 2005 Svennberg, K., Claesson, J. & Hansen, K. K., ”Moisture penetration in a chair seat as a response to daily RH variations in the indoor air”. 7th Symposium on Building Physics in the Nordic Countries. Reykjavik, The Icelandic Building Research Institute, Reykjavik.
- 2005 Rode, C., Peuhkuri, R., Hansen, K.K., Time, B., Svennberg, K., Arfvidsson, J & Ojanen, T., Moisture Buffer Value of Materials in Buildings. 7th Symposium on Building Physics in the Nordic Countries. Reykjavik, The Icelandic Building Research Institute, Reykjavik.
- 2003 Svennberg, K. & Wadsö, L “A modified cup-method for lightweight and highly permeable materials”. IBPC 2, Leuven, Belgium.
- 2002 Svennberg, K. & Harderup, L-E., “Time-dependent moisture properties for plasterboard with surface coating”, Indoor Air 2002, Monterey, CA, USA.

## Reports

- 2006** Rode, C. (editor); Peuhkuri, R; Mortensen, L H.; Hansen, K K; Time, B; Gustavsen, A; Ojanen, T.; Ahonen, J; Svennberg, K.; Harderup, L-E. & Arfvidsson, J.  
“*Moisture Buffering of Building Materials*”, NT Technical Report 592, Nordtest.
- 2005** Svennberg, K., & Rufelt, M., “*Moisture Buffer Performance in Office Premises - Inventory of surface materials and microclimate in three offices at Lund University*”  
Working document to IEA Annex 41 Moist-Eng Subtask II meeting in Trondheim Oct. 26-28, 2005.
- 2005** Wadsö, L. & Svennberg, K., “*Bedrooms without house dust mites. Final report from a preliminary study*”. Building Materials LTH & Building Physics LTH, Lund University
- 2005** Svennberg, K., “*Determination of moisture properties and verification of step-responses for materials and material combinations*”, Building Physics LTH, Lund University
- 2005** Svennberg, K., “*Sorption isotherms for textile fabrics and foam used in the indoor environment*”, Building Physics LTH, Lund University
- 2004** Svennberg, K., “*Determination of moisture properties and verification of step-responses for materials and material combinations*”.  
Working document to IEA Annex 41 Moist-Eng Subtask II meeting in Zürich May 12-14, 2004.
- 2002** Svennberg, K., “*Moisture properties: Step-response for Plasterboard at RH 33-54% and 54-33%, +20°C*” Building Physics LTH, Lund University
- 2001** Harderup, L-E. & Svennberg, K. *The relative humidity of the indoor air and moisture capacity of the interior surfaces.*  
Building Physics LTH, Lund University





## References

- Anderberg, A. (2004). "Moisture in self-levelling flooring compounds". Building Materials, Lund University, Lund, Sweden. TVBM-7911.
- Arfvidsson, J. (1999). "A New Algorithm to Calculate the Isothermal Moisture Penetration for Periodically Varying Relative Humidity at the Boundary." Nordic Journal of Building Physics **2**.
- Arlabosse, Rodier, et al. (2003). "Comparison between static and dynamic methods for sorption isotherm measurements." Drying Technology **21**(3): 479-497.
- Arlan, L., I. Bernstein, et al. (1982). "The prevalence of house dust mites, Dermatophagoides spp, and associated environmental conditions in homes in Ohio." J Allergy Clin Immunol **69**(6): 527 - 32.
- BBR (2002). The Swedish Building Code, The Swedish National Board of Housing, Building and Planning.
- Chan, H.-K., A. R. Clark, et al. (2004). "Physical Stability of Salmon Calcitonin Spray-Dried Powders for Inhalation." Journal of Pharmaceutical Sciences **93**(3): 792-804.
- Chirife, J. and M. P. Buera (1995). "A Critical review of Some Non-equilibrium Situations and Glass Transitions on Water Activity values of Foods in the Microbiological Growth Range." Journal of Food Engineering **25**: 531-552.
- Chirife, J. and S. L. Resnik (1984). "Unsaturated Solutions of Sodium Chloride as Reference Sources of Water Activity at Various Temperatures." Journal of Food Science **49**: 1486-1488.
- Christoffersen, L. D. (1996). ZEPHYR Passive Climate Controlled Repositories. Building Physics. Lund, Lund University, Sweden. TVBH-3028.
- Claesson, J., C.-E. Hagentoft, et al. (1994). "Masked Edge Effects When Measuring Diffusion Coefficients With the Cup Method." Polymer Engineering and Science **34**(10): 821-826.
- Clarke, E. C. W. and D. N. Glew (1985). "Evaluation of the thermodynamic functions for aqueous sodium chloride from equilibrium and calorimetric measurements below 154°C." J. Phys. Chem. Ref. Data **14**(2): 489-610.
- Cunningham, M. J. (1998). "Direct measurements of temperature and humidity in dust mite microhabitats." Clin Exp Allergy **28**(9): 1104 - 12.
- Cunningham, M. J. (1992). "Effective Penetration Depth and Effective Resistance in Moisture Transfer." Building and Environment **27**(3): 379-386.
- Delgado et al. (2006) Can Moisture Buffer Performance be Estimated from Sorption Kinetics? J o Building Physics **29**(4): 281-299
- Diasty, R., P. Fazio, et al. (1993). "Dynamic Modelling of Moisture Absorption and Desorption in Buildings." Building and Environment **28**(1): 21-32.
- Freitas, V. P., M. Krus, et al. (1995). Determination of water diffusivity of porous materials by gamma-ray attenuation and NMR. Moisture Problems in Building Walls, Porto, Portugal.
- Galbraith, G. H. (2003). Alternative methods for measuring moisture transfer coefficients of building materials. Research in Building Physics. J. Carmeliet, H. Hens and Vermeir. Lisse, Swets & Zeitlinger. **1**: 249-254.

- Gibson, P. W., C. E. Kendrick, et al. (1997). An automated dynamic water vapour permeation test method. Performance of Protective Clothing (ASTM STP 1273 vol 6). J. O. Stull and A. Schwope. Conshohocken, PA, American Society for Testing and Materials. **6**: 93-107.
- Goossens, E. (2003). Moisture transfer properties of coated gypsum. Faculty of Architecture, Building and Planning. Eindhoven, indhoven University of Technology: 152.
- Greenspan, L. (1977). "Humidity Fixed Points of Binary Saturated Aqueous Solutions." Journal of Research of the National Bureau of Standards **A. Physics and Chemistry** **81A**(1): 89-96.
- Gustafson and Hall (1974). "Equilibrium moisture content of shelled corn from 50 to 155 F." Transactions of ASAE **17**(1): 120-124.
- Hagentoft, C.-E. (2001). Introduction to Building Physics. Göteborg, Studentlitteratur. ISBN 91 44 01896 7.
- Hailwood, A. J. and S. Horrobin (1946). "Absorption of water by polymers: analysis in terms of a simple model." Trans. Far. Soc. B **42**: 84-92.
- Hansen Kielsgaard, K. (1990). Cup Method for Determination of Water Vapour Transmission Properties of Building Materials. Sources of Uncertainty in the Method. 2nd Symp. Building Physics in the Nordic Countries.
- Hansen, L. D., J. W. Crawford, et al. (1996). "Calorimetric method for rapid determination of critical water vapor pressure and kinetics of water sorption on hygroscopic compounds." International Journal of Pharmaceutics **135**: 31-42.
- Harderup, L.-E. (1983). Luftfuktighet i bostäder. Lund, Building Physics, Lund University. TVBH-3009.
- Harderup, L.-E. (2005). A PC-model to predict Moisture Buffer Capacity in Building Materials according to a NORDTEST Method. Nordic Building Physics Symposium, Reykjavik.
- Hedenblad, G. (1996). Materialdata för fukttransportberäkningar. Stockholm, Byggforskningsrådet.
- Hokoi, S., N. Komoto, et al. (2004). Environmental control for comfortable sleeping, considering both physiological responses of human body and influence of heat and moisture in bedding. CIB W-40. Glasgow.
- Ingersoll, L. R. (1913). "Indoor Humidity." Science **37**(953): 524-525.
- ISO/DIS 15496, (2001). Textiles- Measurement of Water Vapour Permeability of Textiles for the Purpose of Quality Control. Draft International Standard. ISO/DIS 15496.
- Janz, M. and B. F. Johannesson (2001). "Measurement of the moisture storage capacity using sorption balance and pressure extractors." Journal of Thermal Envelope and Building Science **24**(4): 316-334.
- JIS (2003). Test method of adsorption/desorption efficiency for building materials to regulate an indoor humidity - Part 1: Response method of humidity, Japanese Standards Associations. JIS A 1470-1 (2002).
- Joy, F. A. and A. G. Wilson (1965). Standardization of the Dish Method for Measuring Water Vapor Transmission. Humidity and Moisture. Wexler, Reinhold Press. **4**: 259-270.

- Kerestecioglu et al. (1990) Theoretical and Computational Investigation of Simultaneous Heat and Moisture Transfer in Buildings: Effective penetration depth theory. *ASHRAE Trans* 96(1). 447-454.
- Künzel, H. (1965). "Die Feuchtigkeitsabsorption von Innenoberflächen und Inneneinrichtungen." 103-116.
- Künzel, H. (1968). "Die Feuchtigkeitsabsorption der Innenoberflächen von Beton- und Kunststoffwänden." 79-97.
- Künzel, H. M. and K. Kießl (1990.). "Berechnung des Einflusses der Wasserdampfsorption von Oberflächenmaterialien auf das Feuchteverhalten von Wohnräumen." *Gesundheitsingenieur* 111(Heft 5): 217-221.
- Lehto, V.-P. and E. Laine (2000). "Simultaneous Determination of the heat and the Quantity of Vapor Sorption Using a Novel Microcalorimetric Method." *Pharmaceutical Research* 17(6): 701-706.
- Leisen, J., H. W. Beckham, et al. (2002). "Sorption Isotherm Measurements by NMR." *Solid State Nuclear Magnetic Resonance* 22: 409-422.
- Luikov (1968). *Analytical heat diffusion theory*. London, Academic Press.
- Martin, P. C. and J. D. Verschoor (1986). *Cyclical moisture desorption/absorption by building construction and furnishing materials*. Symposium on Air, Infiltration, Ventilation and Moisture Transfer, Fort Worth, TX, USA, Building Thermal Co-ordinating Council.
- McBain, J. W. and A. M. Baker (1926). "A New Sorption Balance." *J Am Chem Soc* 48: 690-695.
- McCullough, E. A., K. Myongsook, et al. (2003). "A comparison of standard methods for measuring water vapour permeability of fabrics." *Meas. Sci. Technol.* 14: 1-7.
- Mitamura, T., C. Rode, et al. (2001). Full scale testing of indoor humidity and moisture buffering in building materials. *ASHRAE Conference Indoor Air 2001*, ASHRAE.
- Newns, A. C. (1950). "The Methods of Determining the Water Vapour Permeability of Laminae. A Review of Literature." *The Journal of the Textile Institute*(4): T 269-308.
- Nilsson, L. e. a. (1993). "The Diffusion of Water Vapour Through Pulp and Paper." *Drying Technology* 11(6): 1205-1225.
- Nyqvist, H. (1983). "Saturated salt solutions for maintaining specified relative humidities." *Int. J. Pharm. Tech. & Prod. Mfr.* 4(2): 47-48.
- Ojanen, T. and M. Salonvaara (2003). A method to determine the moisture buffering effect of structures during diurnal cycles of indoor air moisture loads. *Research in Building Physics*. J. Carmeliet, H. Hens and Vermeir. Lisse, Swets & Zeitlinger: 353-361.
- Okubayashi, S., U. J. Griesser, et al. (2004). "A kinetic study of moisture sorption and desorption on lyocell fibers." *Carbohydrate Polymers* 58: 293-299.
- Padfield, T. (1998). The Role of Absorbent Building Materials in Moderating Changes of Relative Humidity. *Structural Engineering and Materials*. Lyngby, The Technical University of Denmark.

- Padfield, T., R. Peuhkuri, et al. (2002). Non-Isothermal Water Vapour transmission through Porous Insulation. Part 1: The Climate Chamber. Proceedings of the 6th Symposium on building physics in the Nordic Countries, Trondheim, Norway.
- Peralta, P. N. (1995). "Sorption of Moisture by Wood Within a Limited Range of Relative Humidities." Wood and Fiber Science 27(1): 13-21.
- Peuhkuri, R. and 2003, eds. Carmeliet, Hens & Vermeir, Lisse, pp.43-51. (2003). Quantifying time dependent moisture storage and transport properties. Research in Building Physics. Carmeliet, Hens and Vermeir. Lisse, Swets & Zeitlinger: 43-51.
- Plathner, P. and M. Woloszyn (2002). "Interzonal air and moisture transport i a test house. Experiment and modeling." Building and Environment 37: 189-199.
- Ramos, N.M.M and Freitas, V.P (2004) Hygroscopic Inertia as a Function of Transient Behaviour of Covering MAterials, Buildings IX International Conference, USA.
- Rode, Grau, et al. (2001). Model and experiment for hygrothermal conditions of the envelope and indoor air of buildings. Performance of Exterior Envelopes of Whole Buildings VIII. Clearwater Beach, ORNL.
- Rode, C and Grau, K. (2003). Whole-building hygrothermal simulation model. ASHRAE Trans. 109(1)
- Rode, C. (2003). Workshop on Moisture Buffer Capacity - Summary Report. Lyngby, Denmark, BYG-DTU: 33.
- Rode, C., R. Peuhkuri, et al. (2005). Moisture Buffer Value of Materials in Buildings. 7th Symposium on Building Physics in the Nordic Countries. Reykjavik, The Icelandic Building Research Institute, Reykjavik.
- Rode, C., R. a. D. Peuhkuri, et al. (2006). Moisture Buffering of Building Materials. C. Rode, Nordtest.
- Salonvaara, M. H. and Simonson, C. (2000) Mass transfer between indoor air and a porous building envelope: Part II - Validation and Numerical studies, Healthy Buildings 2000, Helsinki
- Simonson, C. and Salonvaara, M. H. (2000) Mass transfer between indoor air and a porous building envelope: Part I - Field measurements, Healthy Buildings 2000, Helsinki
- Speakman, J. B. and C. A. Cooper (1936). "The Adsorption of Water by Wool." J of Text. Inst. 27: T183-196.
- Svennberg, K. (2003). Determination of Moisture properties for Materials Exposed to the Indoor Air. Lund, Department of Building Physics, Lund University. TVBH-3042.
- Svennberg, K., J. Claesson, et al. (*submitted*). "Moisture uptake in a chair seat as a response to daily RH variations in the indoor air. Climatic chamber measurements and calculations."
- Svennberg, K., J. Claesson, et al. (*submitted*). "Microclimates in beds - field measurements and simulation of temperature and moisture conditions in two bed systems."
- Svennberg, K. and L.-E. Harderup (2002). Time-dependent moisture properties for plasterboard with surface coating. Indoor Air 2002, Monterey, CA, USA.

- Svennberg, K., L. Hedegaard, et al. (2004). Moisture Buffer Performance of a Fully Furnished Room. Whole Building Envelope IX. Clearwater Beach, FL, ASHRAE.
- Svennberg, K. and I. Segerholm (2006). Performance of edge sealing systems used in moisture transport experiments. International Building Physics Conference 3. Montreal, Canada, Balkema.
- Svennberg, K. and L. Wadsö (2003). A modified cup-method for lightweight and highly permeable materials. Research in Building Physics. Carmeliet, Hens and Vermeir. Lisse, Swets & Zeitlinger.
- Svennberg, K. and L. Wadsö (*submitted*). "Sorption isotherms for textile fabrics, foams and batting used in the indoor environment."
- Takada, S., S. Hokoi, et al. (2001). Measurement of Moisture Conductivity of Clothing. CIB W-40. New Zealand.
- Time, B. (2002). "Studies on hygroscopic moisture transport in Norway spruce (*Picea abies*)." Holz als Roh- und Werkstoff **60**: 271-276.
- Turl, L. H. and J. E. Kennedy (1965). Method for the Measurement of the Resistance to Water Vapor Diffusion of Clothing Materials. Humidity and Moisture. Wexler. New York, Reinhold Publishing.
- Villadsen, J., K. Hansen Kielsgaard, et al. (1993). Water Vapour Transmission Properties of Wood Determined by the Cup Method. 3rd Symp. Building Physics in Nordic Countries, Copenhagen.
- Wadsö, L. (1993). Studies of Water Vapor Transport and Sorption in Wood, Division of Building Materials, Lund University.
- Wadsö, L. (1994). "An error analysis of the sorption method for wood. Part 1: Theory." Holzforschung **48**(1): 75-81.
- Wadsö, L. (1994). "An error analysis of the sorption method for wood. Part 2: Application." Holzforschung **48**(2): 133-138.
- Wadsö, L. and N. Markova (2002). "A method to simultaneously determine sorption isotherm and sorption enthalpies with a double twin micro calorimeter." Rev Sci Instrum **73**(7): 2743-2754.
- Wadsö, L. and K. Svennberg (2005). Bedrooms without house dust mites. Final report from a preliminary study. Lund, Building Materials and Building Physics. TVBM-7181, TVBH-7230.
- Wadsö, L., K. Svennberg, et al. (2004). "An experimentally simple method for measuring sorption isotherms." Drying Technology **22**(10): 2427-2440.
- Wolf, W., W. E. L. Spiess, et al. (1984). "The water-vapour sorption isotherms of microcrystalline cellulose (MCC) and purified potato starch. Results of a collaborative study." J. Food Eng. **3**: 51-73.
- Zuritz, C., R. P. Singh, et al. (1979). "Desorption isotherms of rough rice from 10 oC to 40 oC." Trans. Am. Soc. Agric. Eng. **22**: 433-444.

**Some Previous Experimental Studies and Field Measurements  
of Moisture Buffering in Indoor Surface Materials.**

Svennberg, K., Lengsfeld, K., Harderup, L-E. and Holm, A.

Submitted to the *Journal of Building Physics*.



# Some Previous Experimental Studies and Field Measurements of Moisture Buffering in Indoor Surface Materials

Kaisa Svennberg<sup>\*</sup>, Lic. Eng., M. Sc.  
Building Physics LTH, Lund University, Sweden

Kristin Lengsfeld, Dipl.-Ing.,  
Fraunhofer-Institute for Building Physics, Holzkirchen, Germany

Lars-Erik Harderup, Ph. D.,  
Building Physics LTH, Lund University, Sweden

Andreas Holm, Ph. D.,  
Fraunhofer-Institute for Building Physics, Holzkirchen, Germany

**KEYWORDS:** moisture buffering, indoor air, surface materials, furnishing, textiles, plaster, material properties.

## Abstract:

The concern for indoor air quality and moisture related health effects in buildings have increased the interest in moisture buffering in surface materials of the indoor environment. The development of more refined hygrothermal calculation tools also calls for a better understanding of the moisture buffering phenomena. In the indoor environment there is a wide variety of materials that have the potential to act as moisture buffers, ranging from traditional building materials as wood and gypsum plaster to textiles. The objectives of this paper are to show that the interest in moisture buffering is not a new issue and that there have been significant laboratory studies made in the past. In a review of previous studies (1960-2000) from Germany and Sweden on surface materials typical for indoor environment, this paper presents results not published in English before.

---

<sup>\*</sup> Corresponding author: Kaisa Svennberg, Building Physics LTH, Lund University, Box 118, SE-221 00 Lund, Sweden, [kaisa.svennberg@byggtek.lth.se](mailto:kaisa.svennberg@byggtek.lth.se)



# 1 Introduction

Already in the early 20<sup>th</sup> century a scientific discussion on the quality of the indoor air and the correlation to the humidity of the air (Bergen 1911; Gulick 1911; Kent, Crowell et al. 1911; Ingersoll 1913; Menzies 1913) took place. The concern for indoor air quality, moisture related health effects in building and comfort have increased the interest for the moisture conditions of the indoor environment over the last 40 years.

The moisture conditions in a room are influenced by the moisture production, the airflow rate between indoor and outdoor environment and the presence of cold surfaces where condensation can take place in addition to this the ability of the materials in the room to absorb and desorb water vapor often referred to as *moisture buffering* plays an important role.

Today there is an increasing interest in the moisture buffering of surface materials in the indoor environment, a phenomena also known as hygric inertia, and not only traditional building materials are taken into account but also furnishing and furniture materials. The development of more refined hygrothermal calculation tools and efforts to optimize heat and ventilation equipment are recent motivations that call for a better understanding of the moisture buffering phenomena.

Several national and international research projects have been initiated during the last years to investigate the moisture buffering of different materials further. The objectives of this paper are to show that the interest in moisture buffering is not a new issue and that there have been significant laboratory studies made on indoor surface materials in the past. It is also an attempt to present a number of earlier studies from 1960 – 2000 on surface materials typical for indoor environment made at the Fraunhofer Institute of Building Physics, Holzkirchen, Germany and Building Physics LTH, Lund University, Lund, Sweden. The results from these studies have not been presented in English before.

The collection has been made with two restrictions. Firstly, only measurements that take into account the time-dependent moisture buffering in materials exposed to indoor air undertaken at the Fraunhofer Institute in Holzkirchen, Germany and Building Physics LTH, Lund University, Sweden have been considered, secondly only publications written in German and Swedish have been studied.

## 2 Laboratory experiments

The publications reviewed were Künzel 1960, Künzel 1965, Künzel 1968, Harderup 1983 and Freij Andersson and Heimsäter 2000, and covers over 40 different materials, all studied by step-response experiments in the laboratory. The materials vary from cementitious building materials to light curtain fabrics side by side with surface coated wood based products. In Table 1-6 the materials investigated are listed together with information on type of step-response method, author and publication year.

### 2.1 Step-response experiments performed in Holzkirchen

Double step-response experiments with both an absorption part and a desorption part were performed on a selection of typical indoor surface materials for Germany during the 1960's (Künzel 1965; Künzel 1968).

Sample sizes of 15 -25 cm were used for laboratory experiments on wall materials and wood. The samples were sealed on the sides and on the back with paraffin, so that the absorption ability of the top side could be investigated. The flooring materials were sealed in similar fashion but the size was dependent on the type of material (25 -25 cm to 25 - 40 cm). The carpet samples were tested close to the normal use, horizontal without moisture sealant on the backside. Samples of different kinds of curtains were cut in samples 30 - 40 cm in size. They were hung up free in the climate chamber so the samples could absorb and desorb moisture on all sides.

All the samples of the test materials were preconditioned in a climate chamber with 20 °C and 40% RH for a few weeks, after that period all materials had reached equilibrium moisture conditions. For the vapor absorption measurement the RH was changed to 80% RH and the increase of weight were measured over three hours. The time period of three hours was changed to 24 hours for measurements which were made later. For a classification of the vapor absorption the absorption ability of each material was described by an absorption-coefficient. The absorption-coefficient describes the relation between the moisture uptake ( $\text{kg/m}^2$ ) and the square root of time ( $\sqrt{h}$ ) for the material and is evaluated from a plot of the moisture uptake.

Figure 1 shows the hygroscopic uptake of moisture of different plasters after a change of the relative humidity from 40% to 80% RH at 20 °C. The increase of RH from 40% to 80% gives an increase of the absolute humidity from 9.4  $\text{g/m}^3$  to 18.8  $\text{g/m}^3$ . Plasters with fine pore systems (lime plaster, lime cement

plaster, cement plaster) had a higher rate of moisture absorption and higher final moisture content than plasters with a coarser pore system (gypsum plaster, white lime plaster).

One way to quantify the ability of different materials to absorb water vapor is to use absorption coefficients. Table 7 shows such coefficients for some materials. Another way to describe the absorption and desorption ability of different materials is shown in Fig. 2. The left side shows the moisture uptake after a climate change of the RH from 40% to 80% RH for 24 hours. After 24 h the test materials are taken back to a climate of 40% relative humidity to show the desorption ability of the materials. In this experiment plasters with and without wallpaper were investigated.

## **2.2 Step-response experiments performed in Lund**

Step response measurements for typical surface materials in the indoor environment in Sweden during the 1980's and late 1990's, including surface coatings were conducted in two main experimental series at Building Physics LTH, Lund University.

The first series (Harderup 1983) consisted of some 30 building and furnish materials typical for a Scandinavian indoor environment, some with surface coatings such as wallpaper and paint. The samples were subjected to a double sided step-change. First an absorptive stage for 3, 6, 11, 48 or 96 hours depending on material type and a second desorptive stage with the same length as the absorptive stage. The experiments were conducted in a small sized climatic chamber, where the climate during wetting was controlled by a commercial humidifier. During the drying the humidifier was turned of and the climate chamber opened to the room air. The room in which the climatic chamber was placed did not have a controlled climate and therefore the humidity of the room air varied with the outdoor climate. The results from the experimental study shows that the furniture fabrics including leather upholstery has the highest moisture uptake together with untreated gypsum wallboard where the paper was directly exposed to the climate variations. The lowest moisture uptake was found for a polyester curtain fabric.

The second measurement series (Freij Andersson and Heimsäter 2000) investigated the impact of surface treatment of wood materials used as surface materials in the indoor environment. In this series the JAR-method (Wadsö, Svennberg et al. 2004) was used for the experimental setup. The step-response experiments were either absorption or desorption and the moisture uptake was determined gravimetrically from the step-change in the ambient conditions

until equilibrium conditions in the samples were reached. The JAR-method based on small glass jars (used for preservatives) with a modified lid was used as small climatic chambers, see Fig.3. Saturated salt solutions were used as humidity generators. The complete experimental set-up was kept in a climate room for temperature stability. The modification of the lid facilitates keeping the sample in the desired ambient climate even under weighing, it also enables easy change of the surrounding RH since the sample and the lid is conveniently moved to another glass jar with another saturated salt solution. In this study these absorptive step changes were used: 33- 44% RH, 44- 54% RH, 54-75% RH and 33-75% RH and these desorptive step changes: 75-54% RH, 54-44% RH, 44-33% RH and 75-33% RH. The study includes massive wood materials (both softwood and hardwood), conifer plywood and wood veneers on particle board. The samples were either left untreated or surface treated with glazing paint or beeswax.

The untreated samples had as expected a larger and quicker moisture uptake with massive birch in top and pine and spruce together with mahogany demonstrating the lowest moisture capacity. The veneered chipboard showed a moisture uptake that corresponds well with what was found for the softwoods.

The impact of the two surface treatments with respect to the size and rate of the moisture uptake differed depending on the substrate material. It is therefore not possible to draw a general conclusion which of the surface treatments that had the largest impact on the moisture buffering ability. It should be noted that both the glazing paint and the beeswax are light surface coatings compared to for example enamel paint or varnish.

### **3 Full scale measurements**

#### **3.1 Moisture buffering experiments in climatic chambers in Holzkirchen**

For these experiments two climatic chambers, 4×4 m<sup>2</sup>, in two test huts at the Fraunhofer-Institute of Building Physics in Holzkirchen were used. An insulation thickness of 6 cm was applied on the interior surface of the walls and the ceiling. In both climatic chambers a frame construction was built, to facilitate the mounting of different wall materials. In one room aluminum panels were inserted on the walls and the ceiling. In the other room gypsum board (12.5 mm) with wallpaper were used on the wall and ceiling. Both test rooms had a constant temperature of 22 °C, regulated with a convector heater. The time and

mass of moisture production and the airflow rate was in both rooms the same for each test. The parameters were changed between following boundaries:

- Time of moisture production between 1 h and 6 h.
- Mass of moisture production between 80 g/h and 370 g/h.
- Air exchange rate between 0.1 and 1.1 air changes per hour.

As a measure of the moisture buffering effect the relative humidity was measured in both rooms. A comparison was made between the increase in relative humidity and the moisture load which was ventilated to the outside.

The air exchange rate in the test rooms were continuously measured using tracer gas technique (decay measurements with argon).

Figure 4 shows the measured RH as function of time for both test rooms. During these experiments the moisture was produced for a period of 3.5 h and in total 700 g of water was evaporated. The results clearly show the impact of moisture buffering in the test room with gypsum board and wallpaper; in the room without any moisture buffering capacity the RH increased more rapidly. The RH was also influenced by the ventilation rate, with lower air exchange rates resulting in higher relative humidity. This is most clearly seen at 3 h when the air exchange rate was low.

Due to the fact that the ventilation rate was measured continuously, it was possible to analyze how much of the produced moisture increased the interior RH, how much was ventilated out and how much was absorbed by the moisture buffering wallpaper. In the case of the test room with wallpaper 57% of the 700 g evaporated water was absorbed in the materials, 23% increased the RH and 20% was ventilated out. In the non-buffering room with aluminum panels 33% of the evaporated water was ventilated out of the room. The rest 67% (ca. 460 g) increased the RH of the interior air. This is equivalent to an average increase of the absolute humidity by almost 12 g/m<sup>3</sup>.

### **3.2 Whole building measurements and simulations conducted in Lund.**

A field study of 5 dwelling of different types in the south of Sweden combined with computer simulations of non-stationary moisture balance in dwellings was conducted in the winter of 1982-83.

The field study was conducted during the heating season and consisted of measurements of temperature, RH and air exchange for five dwellings in the southern part of Sweden. The five dwellings were picked at random and the selection was therefore heterogeneous regarding building age, household size and composition, type of ventilation system, residential area etc. The residents kept written records of all activities that could influence the total moisture balance of the building. In order to study the impact of a known moisture source, humidifiers were placed at different locations in the buildings.

The simulations of moisture conditions of the indoor air in the buildings were based on the transient moisture balance for a room (or a zone) shown in Eq. 1. This is an analytical expression for the change in vapor content,  $v_i$ , of the indoor air over time. The temperature dependency for the volume expansion of the air is neglected.

$$\frac{dv_i}{dt} = \frac{\sum G_{ms} - \sum_{j=1}^n g_{mbj} A_{sj} - q(v_i - v_e) - \beta_v(v_i - v_{ss}) A_c}{V} \quad (\text{kg}/(\text{m}^3 \text{ s})) \quad (1)$$

Here, the moisture supply,  $G_{ms}$ , is assumed to be composed of two parts. A relatively constant supply from plants, inhabitants and pets and short moisture supply pulses that change almost momentarily. These short moisture supply pulses comes from cooking, washing, showers, baths, and other activities that are carried out during shorter periods of the day. The ventilation flow rate,  $q$ , and the vapor content of the indoor air,  $v_i$ , and outdoor air,  $v_e$ , are also important. If surfaces below the dew point of the indoor air are present surface condensation will also play an important role for moisture conditions indoors. This can be calculated with knowledge about the surface moisture transfer coefficient,  $\beta_v$ , the area of the cold surface,  $A_c$ , and the surface dew point expressed as the vapor content,  $v_s$ .

The simulations were done in two steps: first the moisture buffering and the condensation on cold surfaces were neglected, secondly all elements of Eq. 1 were included.

The results from the comparison between the measurements of the RH in the room and the simulations show large discrepancies when the moisture buffering effect of surface materials were not taken into account see Fig.5. These findings are supported by more recent studies, for example Plathner and Woloszyn (2002).

## 4 Discussion

A large number of materials from various types of indoor materials have been experimentally tested over the years. For some of them the results should still be useable and these early experiment can also help us design good experimental set-ups today.

All the laboratory experiments in this review lack sufficient information on air velocities and surface moisture transfer coefficients for the experimental set-ups. This is a major problem and makes it hard to compare different studies. However, the determination or estimation of surface mass transfer coefficients is still to day a major problem with similar studies. Very little information about the correctness of the step-change was also found. The time scale for a step in the ambient climate to be fully developed depends on the means to generate the humidity, the size of the climate chamber and the mixing of the air.

The choice of experimental methods and evaluation procedures, especially for light and highly permeable materials, needs to be taken into carefully consideration. For example, methods with large air gaps of stagnate air when measuring textiles are clearly unsuitable. Also the use of slope of a straight moisture absorption curve, if plotted against square root of time, is unsuitable for repeated dynamic loading experiments, where the sample is not in equilibrium when the ambient conditions are changed.

There is little information in the studies reviewed here concerning the manner used to establish that equilibrium conditions were reached. Generally the equilibrium criteria are stated either as a certain time (usually based on earlier experience) or simply as the limit when the accuracy of the balance is reached. Both approaches give room for large deviations from true equilibrium conditions and the possible error this causes is seldom discussed. Wadsö and co-workers (Wadsö, Svennberg et al. 2004) proposed an equilibrium criteria taking into account the moisture capacity of the material and also discussed the necessary accuracy of the balance as a function of the sample size (weight).

The studies presented here show, in different ways that most common surface materials of the indoor environment interact with the moisture variations that occurs on a diurnal basis in most dwellings and offices. The interaction between the indoor air and the surface materials will as a result moderate the moisture variations in the indoor air. Surface coatings will slow down the moisture transport to and from the surface material. If the surface coating has a large surface resistance a material with high moisture buffering capacity, e.g.,

wood can become inert to diurnal moisture variations due to this decrease in moisture exchange.

The results of the vapor absorption ability which were measured in the laboratory were compared to the experiments in the test rooms with real climate conditions. This shows which influence the vapor absorption has to the relative humidity in the air. The field measurements in combination with the simulation show that moisture buffering is an indispensable element in the description of the moisture balance of the indoor air.

These earlier studies on moisture buffering contain practical experience that can be useful when new experiments and field measurements are designed.

## References

- Bergen, J. Y. (1911). "House Air." Science **34**(874): 407-408.
- Freij Andersson, K. and A. Heimsäter (2000). Tidsberoende fuktabsorption och fukt-desorption i trätytor inomhus. Examensarbete IB. Malmö, Malmö Högskola.
- Gulick, L. H. (1911). "The Air We Breathe in Buildings." Science **33**(844): 326-328.
- Harderup, L-E. (1983). Luftfuktighet i bostäder. Lund, Building Physics, Lund University.
- Ingersoll, L. R. (1913). "Indoor Humidity." Science **37**(953): 524-525.
- Kent, W., W. J. Crowell, et al. (1911). "The Air We Breathe." Science **33**(848): 486-491.
- Künzel, H. (1960). "Die "klimaregelnde Wirkung" von Innenputzen." Gesundheits-Ingenieur **81**(7): 196-201.
- Künzel, H. (1965). Die Feuchtigkeitsabsorption von Innenoberflächen und Inneneinrichtungen. Report of building research: 102-116.
- Künzel, H. (1968). "Die Feuchtigkeitsabsorption der Innenoberflächen von Beton- und Kunststoffwänden." 79-97.
- Menzies, A. W. C. (1913). "Indoor Humidity." Science **37**(959): 758.
- Plathner, P. and M. Woloszyn (2002). "Interzonal air and moisture transport in a test house. Experiment and modeling." Building and Environment **37**: 189-199.
- Wadsö, L., K. Svennberg, et al. (2004). "An experimentally simple method for measuring sorption isotherms." Drying Technology **22**(10): 2427-2440.



## Figures

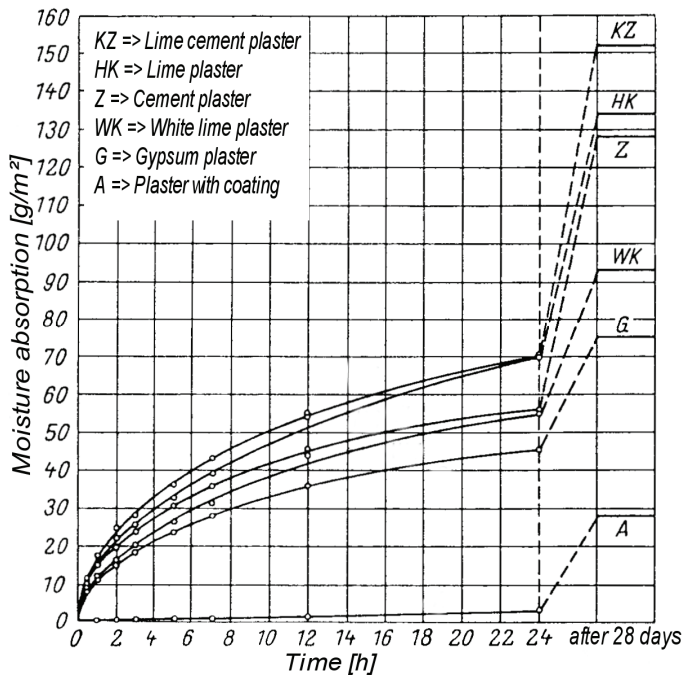


Figure 1. The moisture uptake of different plasters, after a step change in the RH between 40% to 80%.

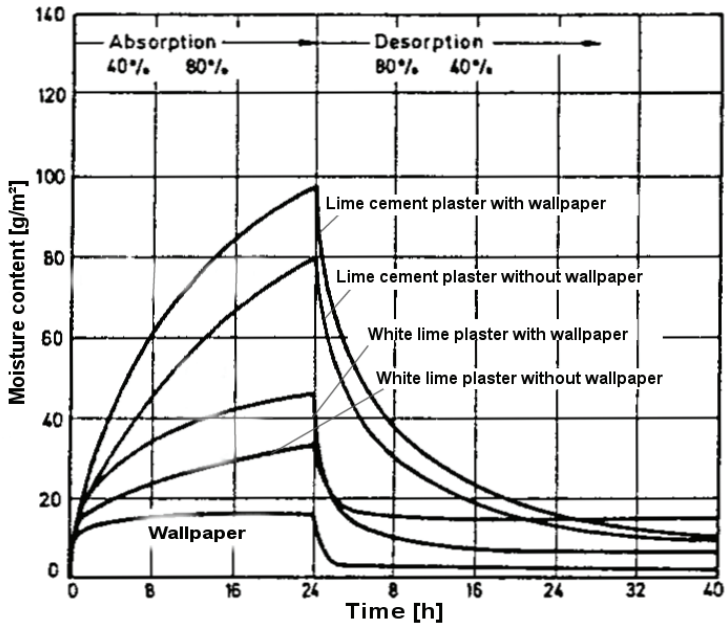
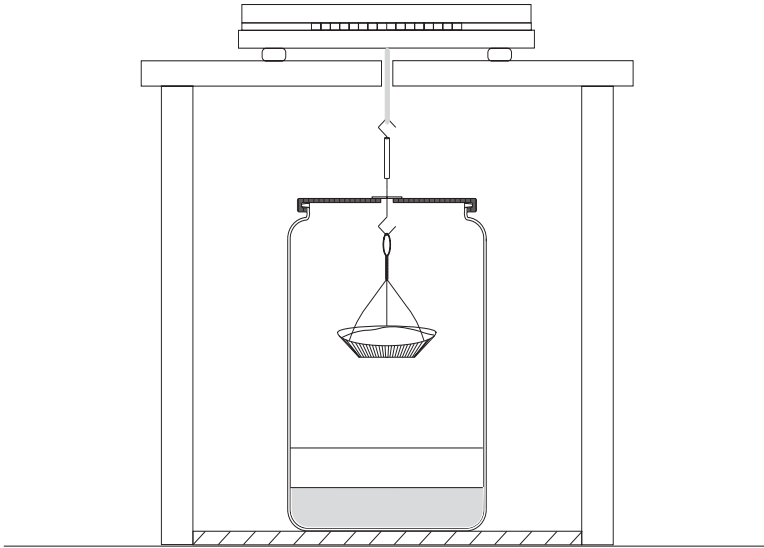


Figure 2. The moisture uptake of lime cement plaster (KZP) and white lime plaster (WKP) with and without wallpaper, after a step change in the RH between 40% to 80%.



*Figure 3. The experimental setup for the JAR-method. Ordinary glass jars are used with saturated salt solutions as humidity generators. The lid is modified, with a large hole covered by a washer with small hole, to allow the sample to remain inside the JAR during the complete experiment. The sample is hung in a steel wire and a rubber tube on the steel wire acts both as seal for the minute hole in the washer and as a stopper so the sample is stopped from falling down when the sample is not in a weighing position. The sample is weighed with below-balance technique.*

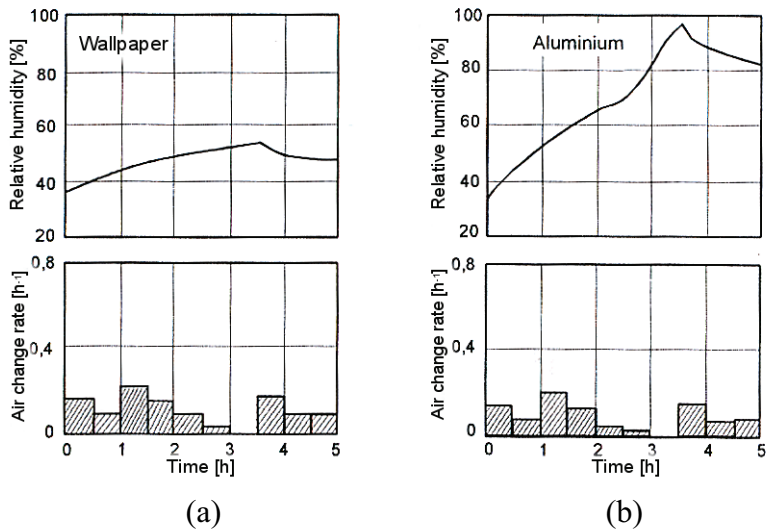


Figure 4. *a*: Test room with wallpaper. *b*: Reference room with aluminum panels. At the top is the RH in the test rooms shown during the moisture production of 700 g/h during 3.5 hours. In the bottom are the air change rates in the test rooms, which were influenced by the outdoor conditions.

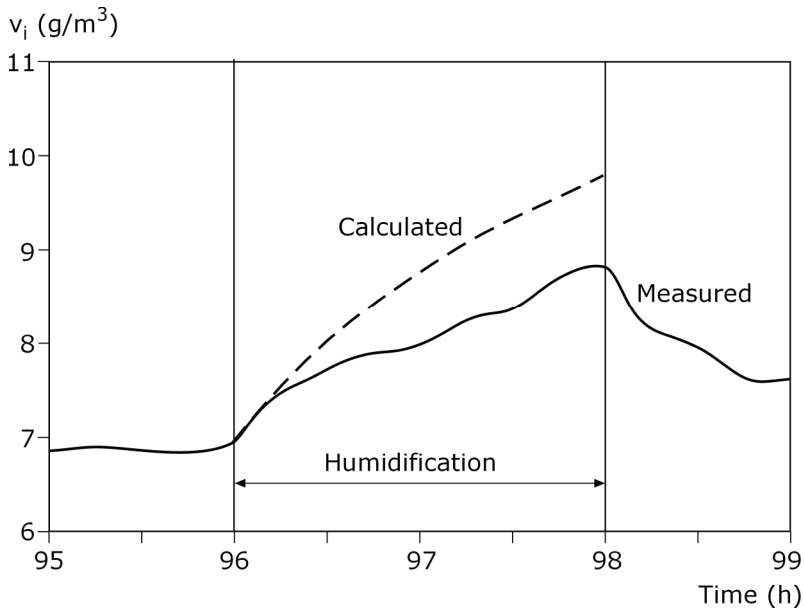


Figure 5. Comparison between measured indoor vapor content (solid line) and calculated indoor vapor content when the moisture buffering is not taken into account (dashed line) for a house in Southern Sweden subjected to humidification by a humidifier.

## Tables<sup>†</sup>

**TABLE 1.** Wood materials tested with regard to moisture buffering.

<b>Material</b>	<b>Experimental method</b>	<b>Author (Year)</b>
Beech	Double sided step-response Absorption step-response Desorption step-response	Künzel, 1968 Freij Andersson & Heimsäter, 2000
Birch	Double sided step-response Absorption step-response	Künzel, 1968 Freij Andersson & Heimsäter, 2000
Gabon	Double sided step-response	Künzel, 1968
Lark	Double sided step-response	Künzel, 1968
Limba <sup>‡</sup>	Double sided step-response	Künzel, 1968
Mahogany	Absorption step-response Desorption step-response	Freij Andersson & Heimsäter, 2000
Oak	Double sided step-response Absorption step-response Desorption step-response	Künzel, 1968 Freij Andersson & Heimsäter, 2000
Pine	Double sided step-response Absorption step-response Desorption step-response	Künzel, 1968 Freij Andersson & Heimsäter, 2000
Spruce	Absorption step-response Desorption step-response	Freij Andersson & Heimsäter, 2000
Teak	Double sided step-response	Künzel, 1968

<sup>†</sup> In table 1-6 the materials tested and reported in the studies reviewed here are presented; material, experimental method, author and publication year. Double sided step-response describes experimental methods where the sample is first subjected to an absorptive step-change directly followed by a desorptive step-change and where a strict time criteria is used for when to change. Absorption and desorption step-response denotes experimental methods where the sample is subjected to a absorptive or desorptive step-change and where the ambient conditions are changed first when "equilibrium" conditions are reached. Most equilibrium criteria are based on the accuracy of the balance.

<sup>‡</sup> An African wood used for furnishings

**TABLE 2.** Board materials tested with regard to moisture buffering

<b>Material</b>	<b>Experimental method</b>	<b>Author (Year)</b>
Beech-veneer on particleboard	Absorption step-response Desorption step-response	Freij Andersson & Heimsäter, 2000
Birch-veneer on particleboard	Absorption step-response Desorption step-response	Freij Andersson & Heimsäter, 2000
Chipboard painted	Double sided step-response	Harderup, 1983
Chipboard with plastic coated wallpaper	Double sided step-response	Harderup, 1983
Chipboard with textile wallpaper	Double sided step-response	Harderup, 1983
Chipboard with vinyl wallpaper	Double sided step-response	Harderup, 1983
Glue laminated birch	Absorption step-response Desorption step-response	Freij Andersson & Heimsäter, 2000
Gypsum board	Double sided step-response	Harderup, 1983
Gypsum board painted	Double sided step-response	Harderup, 1983
Gypsum board with plastic coated wallpaper	Double sided step-response	Harderup, 1983
Gypsum board with textile wallpaper	Double sided step-response	Harderup, 1983
Gypsum board with vinyl wallpaper	Double sided step-response	Harderup, 1983
Oak-veneer on particleboard	Absorption step-response Desorption step-response	Freij Andersson & Heimsäter, 2000
Plywood	Absorption step-response Desorption step-response	Freij Andersson & Heimsäter, 2000

**TABLE 3.** Flooring materials tested with regard to moisture buffering

<b>Material</b>	<b>Experimental method</b>	<b>Author (Year)</b>
Ceramic floor tiles	Double sided step-response	Künzel, 1968
Linoleum	Double sided step-response	Künzel, 1968
Pre-finished parquet floor birch	Double sided step-response	Harderup, 1983
Pre-finished parquet floor merbau	Double sided step-response	Harderup, 1983
Pre-finished parquet floor oak Waxed oak	Double sided step-response Double sided step-response Absorption step-response Desorption step-response	Künzel, 1968 Harderup, 1983 Freij Andersson & Heimsäter, 2000
Pre-finished parquet floor pine	Double sided step-response	Harderup, 1983
Stragula <sup>§</sup>	Double sided step-response	Künzel, 1968
Terazzo	Double sided step-response	Künzel, 1968
Vinyl floor tiles Vinyl flooring	Double sided step-response Double sided step-response	Künzel, 1968 Harderup, 1983

---

<sup>§</sup> A bitumen based floor material used in the 1960's.



**TABLE 4.** Textile materials tested with regard to moisture buffering

<b>Material</b>	<b>Experimental method</b>	<b>Author (Year)</b>
Wool	Double sided step-response Double sided step-response	Künzel, 1968
Rayon	Double sided step-response	Künzel, 1968
Viscose	Double sided step-response	Künzel, 1968
Polyester/ Cotton (Drapery)	Double sided step-response	Künzel, 1968
Cotton	Double sided step-response	Harderup, 1983
Cotton/acrylic	Double sided step-response	Harderup, 1983
Hair yarn rug	Double sided step-response	Künzel, 1968
Sisal carpet	Double sided step-response	Künzel, 1968
Half-synthetic carpet	Double sided step-response	Künzel, 1968
Synthetic carpet	Double sided step-response Double sided step-response	Künzel, 1968 Harderup, 1983
Polyester	Double sided step-response	Harderup, 1983
Acrylic/flax	Double sided step-response	Harderup, 1983
Flax/cotton	Double sided step-response	Harderup, 1983
Polyester/polyurethane	Double sided step-response	Harderup, 1983
Flax	Double sided step-response	Harderup, 1983
Upholster leather	Double sided step-response	Harderup, 1983

**TABLE 5.** Cementitious materials and plasters tested with regard to moisture buffering

<b>Material</b>	<b>Experimental method</b>	<b>Author (Year)</b>
Reinforced concrete	Double sided step-response	Künzel, 1965
Aerated concrete	Double sided step-response	Künzel, 1965
Lime plaster (HKP)	Double sided step-response	Künzel, 1965
Lime cement plaster	Double sided step-response	Künzel, 1965
Cement plaster (ZP)	Double sided step-response	Künzel, 1965
White lime plaster (WKP)	Double sided step-response	Künzel, 1965
Gypsum plaster (GP)	Double sided step-response	Künzel, 1965
Plaster with coating (A)	Double sided step-response	Künzel, 1965

**TABLE 6.** Other materials common in the indoor environment tested with regard to moisture buffering

<b>Material</b>	<b>Experimental method</b>	<b>Author (Year)</b>
Wallpaper; Plastic, textile and vinyl	Double sided step-response	Harderup, 1983
Plastic foil	Double sided step-response	Künzel, 1968
Beeswax surface coating**	Absorption step-response Desorption step-response	Freij Andersson & Heimsäter, 2000
Water-based glaze <sup>4</sup>	Absorption step-response Desorption step-response	Freij Andersson & Heimsäter, 2000

---

\*\* Applied on birch, beech, mahogany, pine, spruce, oak, chipboard with birch – veneer, beech-veneer, oak-veneer, glue laminated birch and plywood.

**TABLE 7.** Absorption-coefficient of different materials. Künzel (1965,1968)

<b>Material</b>	<b>Absorption- coefficient (kg/m<sup>2</sup>√h *10<sup>-3</sup>)</b>
<u>Interior plaster, concrete</u>	
White lime plaster, gypsum plaster	7 – 12
Lime cement plaster	14 - 16
Concrete (B15, B25, B45)	7 - 9
Interior plaster and concrete with wallpaper	10 - 20
<u>Wood</u>	
Pine, spruce, beech, nature	20 - 25
Oak, nature	12
Oak, waxed (Floor)	3
<u>Textile</u>	
Curtain, natural fibers 0,15 - 0,3 kg/m <sup>2</sup>	5 - 15
Carpet, natural fibers	30 - 36
Carpet, synthetic fibers	15

**An Experimentally Simple Method for  
Measuring Sorption Isotherms.**

Wadsö, L., Svennberg, K. and Dueck, A. (2004).

Published in *Drying Technology* **22**(10): 2427-2440.



## An Experimentally Simple Method for Measuring Sorption Isotherms

Lars Wadsö,<sup>1,\*</sup> Kaisa Svennberg,<sup>2</sup> and Ann Dueck<sup>3</sup>

<sup>1</sup>Building Materials, Lund University, Lund, Sweden

<sup>2</sup>Building Physics, Lund University, Lund, Sweden

<sup>3</sup>Clay Technology AB, IDEON Research Center, Lund, Sweden

### ABSTRACT

We describe a simple, yet practical and precise, way of measuring sorption isotherms with each sample in its own glass jar with a saturated salt solution. The measurements are done with below-balance weighing and with the sample kept inside the closed jar during the whole measurement period, providing constant relative humidity (RH) conditions. The technique has been tested on microcrystalline cellulose and bentonite clay. The agreement with literature values was good; the differences seen for bentonite at high RH are discussed in terms of the slow attainment of equilibrium for this material.

---

\*Correspondence: Lars Wadsö, Building Materials, Lund University, Box 118, 221 00, Lund, Sweden; E-mail: lars.wadso@byggttek.lth.se.

*Key Words:* Sorption isotherm; Measurement method; Saturated salt solutions; Glass jar.

## INTRODUCTION

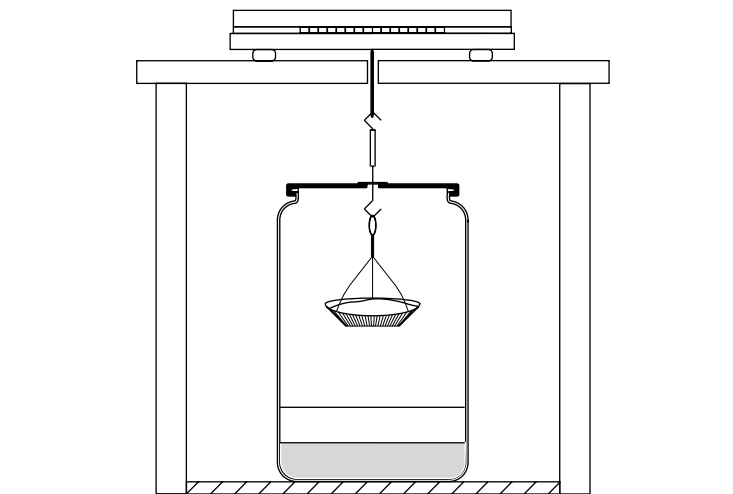
Measurement of sorption isotherms—equilibrium water gain as a function of relative humidity (RH)—is a common practice in many fields of science and engineering, e.g., food science, building material science, soil science and pharmaceutical science. Many methods are based on the equilibration over saturated salt solutions, e.g., the method tested in an European COST study.<sup>[1]</sup> Recently the use of automated sorption balances have increased.<sup>[2–4]</sup> More advanced methods like NMR<sup>[5]</sup> and sorption microcalorimetry<sup>[6]</sup> are also used.

Simple methods to determine sorption isotherms usually rely on conditioning above saturated salt solutions that keep constant relative humidities (RH) and gravimetric methods to determine the moisture content in the sample. In many such methods the RH around the sample is disturbed during each weighing because the sample has to be taken out of the controlled RH for each measurement. A solution to this is to keep both the balance and the sample at the same RH, but this is impractical, as many different RH are needed to determine a complete sorption isotherm.

This article deals with a further development of the methods of Gustafson and Hall<sup>[7]</sup> and Zuritz et al.<sup>[8]</sup> in which each sample is kept in its own glass jar with saturated salt solutions and the weighing of the sample is made while the sample is still in the jar.

## METHOD

Saturated solutions of different salts give different constant relative humidities (RH) over their surfaces<sup>[9]</sup> (unsaturated solutions may also be used if one keeps control of the concentration of the solution). When a sorption isotherm is to be measured with saturated salt solutions each sample is kept over a salt solution and weighed regularly. When the mass of the sample does not change anymore according to the equilibrium criterion being used, that mass is noted as the equilibrium mass of the sample at that RH. Thereafter the sample may be taken to another RH where the procedure is repeated. The moisture content of a sample



**Figure 1.** The measurement set-up with the sample in weighing position. The sample hangs in the wire that goes through the hole in the lid. This hole is made quite tight by the washer floating on top of the lid (and the rubber tubing on the wire that tightens the hole when weighing is not being made). Note that the glass jar stands on a glass plate so it is easy to place it in the correct position for a weighing.

is usually based on the dry mass of the sample and the sample is therefore dried before or after the measurement.

Figure 1 shows the set-up used in the present method. An ordinary 750 mL glass jar for food preserves with a lacquered metal screw lid is used. The sample holder hangs in a 0.70 mm stainless steel wire through a hole (diameter 5.0 mm) in the metal lid. The hole is covered with a polycarbonate washer (diameter 11 mm, thickness 1.6 mm) with a 0.80 mm hole in it that allows the wire to freely pass through. The washer is free to move on the upper surface of the lid. A small silicone rubber tube (inner diameter 0.64 mm) is placed on the wire to keep the sample pan in position above the salt solution and to seal the hole in the washer when measurements are not being done. The silicone tubing is cut perpendicular to its length to minimize leakage through the hole in the washer.

The top of end of the wire is made into a hook that can be attached to the below-balance hook at the bottom side of a balance for weighing. When taking a measurement the wire is attached to the balance and the jar is adjusted so that the wire is swinging freely, moving the washer



slightly back and forth. After about 10 s when the swinging have stopped, the wire will go centrally through the hole in the washer without touching the washer. Then a reading is made on the balance and the wire is unhooked from the balance. The jars are placed on a glass plate during the weighing. Because of the low glass-to-glass friction this makes it easier to adjust the position of the jar to get stable readings.

In order to minimize the leakage and to obtain stable measurements the holes in the steel lids should be made in such a way that the top surfaces are perfectly flat. Otherwise, there will be leakages under the washers or the washers will not move freely on top of the lid making it difficult to get stable measurements. A too small hole in the washer will also give stability problems.

A Sartorius balance BP 221 S with below-weighing and a last digit of 0.1 mg was used. The balance was placed on a stand to enable below-balance weighing, see Fig. 1. The measurements were performed in a 55% RH climate room with a temperature of  $20 \pm 0.5^\circ\text{C}$ .

An important part of a method to measure sorption isotherms is the equilibrium criterion used. As different materials can take quite different times to reach equilibrium because of internal diffusion limitations and non-Fickian phenomena<sup>[10]</sup> it is important that the change in the sample mass with time is followed until it is certain that the sample has come close enough to equilibrium for the chosen purposes. It is not efficient to set a certain time when it is thought that equilibrium is attained and then only make one measurement.

In the present study the following criterion was used to decide when a measurement could be stopped:

$$\Omega = \frac{dm/m_i}{dt} \times \frac{\varphi_f - \varphi_i}{(m_f - m_i)/m_i} \quad (1)$$

The equilibrium criterion  $\Omega$  takes into account the mass ( $m$ ) of the sample and moisture capacity of the sample in the relative humidity ( $\varphi$ ) interval used in the measurement ( $i$  and  $f$  refers to the initial and final states of a sorption step). The first factor is the fractional mass change rate. The second factor is the inverse of the moisture capacity expressed in terms of  $m$  and  $\varphi$ . When the major part of a sorption step has taken place  $m(t) \approx m_f$  and we can write:

$$\Omega = \frac{dm}{dt} \times \frac{\varphi_f - \varphi_i}{m(t) - m_i} \quad (2)$$

In the present article we have considered a sorption step to be finished when  $\Omega$  is less than the rather arbitrarily chosen value of  $5 \times 10^{-9} \text{ s}^{-1}$ .

## TEST MEASUREMENTS

We have used the method with glass jars to measure absorption isotherms for two materials at 20°C: microcrystalline cellulose (MCC, Avicel PH-101, SERVA Electrophoresis, Heidelberg, Germany) and bentonite clay (commercial bentonite clay, with the quality symbol MX-80 from American Colloid Co., which is a blend of natural Wyoming bentonite horizons<sup>[11]</sup>). The MCC measurements were done at six different RH (33, 43, 54, 75, 85, and 95%) using saturated solutions of six salts (MgCl<sub>2</sub>, K<sub>2</sub>CO<sub>3</sub>, Mg(NO<sub>3</sub>)<sub>2</sub>, NaCl, KCl, KNO<sub>3</sub>). Samples of 3.5 g MCC were used and placed in aluminum sample pans that were hung about 2 cm above the salt solution surfaces. Three samples in individual jars were used at each RH. To increase the sample mass a stainless steel weight of about 20 g was attached to each sample pan. This was done to minimize leakage, cf. Discussion below. The samples were kept over the salt solutions for about two weeks when equilibrium was reached according to the equilibrium criterion. The dry mass of the MCC samples was determined by conditioning over drying agent (0.4 nm molecular sieves) in the method jars for ten days until equilibrium was reached.

The bentonite clay measurements were done at 6 different RH (11, 33, 59, 75, 85, and 93%) using saturated salt solutions of five salts (LiCl, MgCl<sub>2</sub>, NaBr, NaCl, KCl) plus one aqueous unsaturated NaCl solution for 93% RH. Only one sample was used at each RH. The unsaturated aqueous solution was a two molal solution of NaCl. The vapor pressure  $p$  over this solution is 2179 Pa<sup>[12]</sup> and the saturation vapor pressure  $p_{\text{sat}}$  over pure water is 2339 Pa at 20°C. Since the relative humidity, RH, is defined as  $\text{RH} = p/p_{\text{sat}}$  the 2 molal NaCl solution at 20°C gives  $\text{RH} = 93\%$ . The jar with the unsaturated aqueous solution was exchanged four times during the testing time to minimize the effect of evaporation and leakage. Each solution was weighed before and after being used and the mass loss was found to be less than 2% of the total weight of the solution.

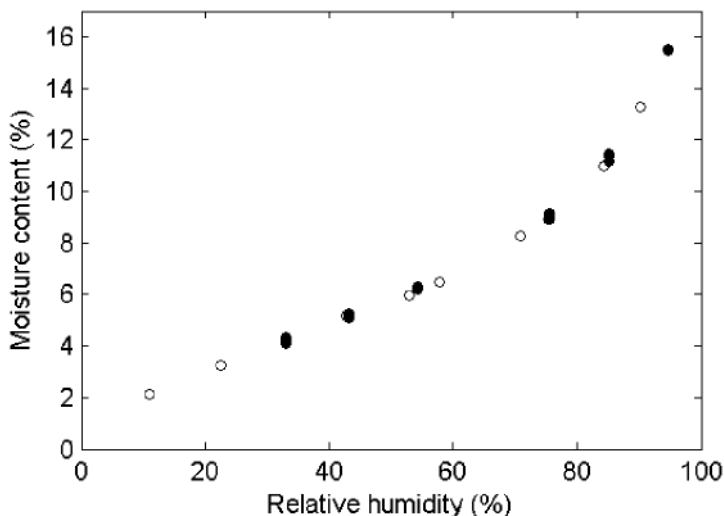
Samples of 10 g bentonite, with an initial moisture content of 0.4%, were placed a couple of cm above the saturated or unsaturated aqueous solutions in the same type of sample pans as used for the MCC. The initial state of the bentonite was a result of conditioning over drying agents for 28 days. Stainless steel weights, as mentioned above, were also used here. After 82 days the tests were finished (Eq. (2) gave a  $\Omega$  less than  $5 \times 10^{-9} \text{ s}^{-1}$ ). The samples were dried at 105°C for 24 h and then placed over molecular sieves (0.4 nm) in the glass jars

and weighed. The weight after oven drying was regarded as the dry mass.

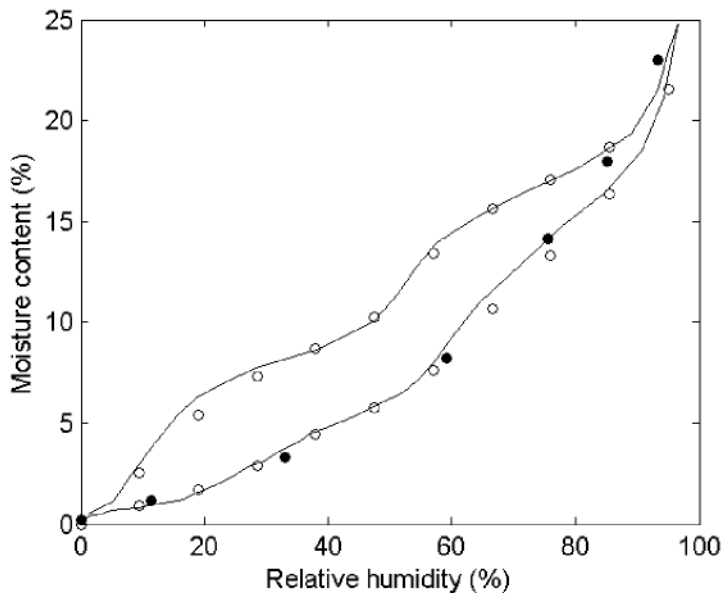
The sorption isotherm for bentonite clay MX-80 was also determined with a sorption balance (DVS 1000, Surface Measurement Systems, London, UK<sup>[13]</sup>). The initial weight of the material was 15 mg and the sample was initially dried in the instrument in dry nitrogen. The temperature during this test was 25°C. Both absorption and desorption were determined in steps of 9.5%. Each sorption step took 5–20 h. The sorption balance measurements were not done with the equilibrium criterion being used for the jar measurements.

## RESULTS

Figure 2 shows the absorption isotherm measured for MCC and Fig. 3 the absorption isotherm for bentonite clay. For MCC the highest standard deviation was 0.14% moisture content (at 85% RH).



*Figure 2.* Measurements of the sorption isotherm for microcrystalline cellulose (MCC) made with the present method at 20°C (filled circles) compared to literature values from Wolf et al.<sup>[1]</sup> measured at 25°C (open circles). Moisture contents are calculated on a dry basis.



**Figure 3.** Measurements of the sorption isotherm for bentonite clay made with the present method at 20°C (filled circles) compared to sorption balance measurements at 25°C (open circles) and literature values from Kraehenbuehl et al.<sup>[14,15]</sup> at 20°C (solid line). Moisture contents are calculated on a dry basis.

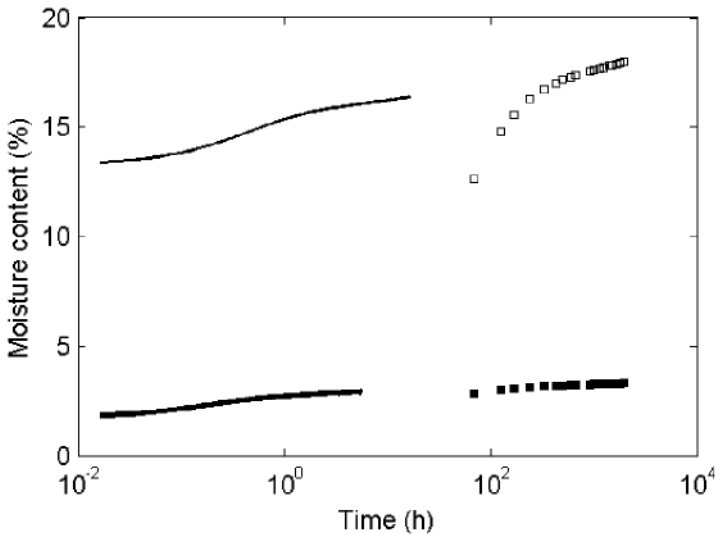
## DISCUSSION

There is a good agreement regarding MCC between the present method and the isotherm obtained with another method by the COST collaborative study.<sup>[1]</sup> The COST method used weighing bottles in which the samples were placed. The samples were first dried over phosphorus pentoxide and thereafter conditioned over saturated salt solutions in sorbostats. The measurements were done outside the conditioning environment and the equilibrium was determined on day 7 after the samples have been placed in the sorbostats. These measurements were done at 25°C. The dry weight was determined after the samples had been dried in 105°C for 4 h.

Figure 3 shows a comparison with results regarding bentonite from Kahr, Kraehenbuehl and co-workers<sup>[14,15]</sup> determined with a gravimetric apparatus of the McBain type.<sup>[16]</sup> The initial weight was approximately 0.8 g and before the water uptake the material was dried

for 24 h at 100°C and at a pressure of  $10^{-4}$  to  $10^{-5}$  mbar. The test was made at 20°C.

The bentonite clay is used in this investigation as an example of a slowly sorbing natural material for which the jar method works quite well as it is possible to conduct long term studies without excessive costs. The results from the jar method agree well with both the sorption balance measurements and the results from Kahr, Kraehenbuehl and co-workers<sup>[14,15]</sup> in the lower region of RH but show higher moisture contents in the high range of RH. To study this phenomenon further the increase in moisture content with time in two RH ranges is shown in Fig. 4. It is seen that for both methods the water content is still increasing when the measurements were terminated, but the jar measurements are closer to equilibrium as they have been continued for longer time. Our sorption balance measurements were not made with the equilibrium criterion used for the jar measurements. This time dependence in the water uptake is a possible reason for the difference in water content shown at higher RH in Fig. 3. The very slow changes



**Figure 4.** Increase in water content as a function of the logarithm of time for sorption steps made with a sorption balance and the present jar method, ending at approximately the same RH-values. Legend: sorption balance, final RH 28.5% (thick line); sorption balance, final RH 85.5% (thin line); jar method, final RH 33% (filled squares); jar method, final RH 85 % (open squares).

in moisture content at the end of the experiments with the present method are probably caused by slow re-organization of the sorbed water, i.e., a type of non-Fickian behavior.

There are a number of advantages with the present method compared to most other commonly used simple experimental methods to measure sorption isotherms:

- There is no significant RH-disturbance to the sample during a measurement as there is only a minute hole between the washer and the wire. This is the main difference between the present method and the methods used by Gustafson & Hall<sup>[7]</sup> and Zuritz et al.<sup>[8]</sup> in which there was a rather large opening in the lid during each measurement.
- A sample is easily transferred from one RH-condition to another simply by moving the lid together with the sample from one jar to another. If this is done quickly in a suitable RH, the disturbance will be small (e.g., the sample will not change limb on the hysteresis loop).
- If the jars and the tubing are resistant to 105°C, the set-up can be used for drying samples at this standard temperature. This is further discussed below.

Errors from the measurements and uncertainties in the ambient conditions will cause an error in the determined points of moisture content as a function of RH on the sorption isotherm. This error is made up from mainly three parts: errors in the weighing, errors in the generated RH, and errors caused by variations in temperature.

A simple error analysis for the weighing may be made as follows. Consider a sample of dry mass  $m_0$  and a mass  $m_1$  at a moisture content  $u$  on a dry basis. Then:

$$u = \frac{m_1 - m_0}{m_0} \quad (3)$$

Assume that both mass determinations have absolute errors of  $\Delta m$  and that the errors have different signs (worst case). Then:

$$u + \Delta u = \frac{m_1 + \Delta m - (m_0 - \Delta m)}{m_0 - \Delta m} \quad (4)$$

Here,  $\Delta u$  is the error in the moisture content. If we solve  $\Delta u$  from Eqs. (3) and (4) and simplify the expression by noting that  $\Delta m$  is much smaller

than  $m_0$ , and making the approximation valid for low moisture contents that  $m_0 + m_1 \approx 2m_0$  we get:

$$\Delta u \approx \frac{2\Delta m}{m_0} \quad (5)$$

For the present set-up with glass jars we have found that repeated weighing gives us a standard deviation of about 0.2 mg, i.e., more than 99% (three standard deviations) of all results are within about  $\pm 0.6$  mg. If  $\Delta m = 0.6$  mg and  $m_0 = 10$  g we get  $\Delta u \approx 0.0001 = 0.01\%$ . We therefore suggest the use of a balance with a last digit of 0.1 mg for samples of 10 g.

The relative humidity (RH) of the used saturated salt solutions may be found in Greenspan,<sup>[9]</sup> who also gives uncertainty limits for each salt. The uncertainties estimated by Greenspan are 0.14–0.33% RH for all our salts except for  $\text{KNO}_3$  that has a higher uncertainty of 0.66% RH. Except for  $\text{KNO}_3$ , these uncertainties are rather low.

Another factor that is often overlooked is the effect of hysteresis. Normally one measures an isotherm either in absorption (by initially drying the sample) or in desorption (by initially humidifying the sample). This works well as long as the RH is constant. However, if the RH fluctuates the samples will tend to absorb and desorb cyclically, resulting in scanning curves between the limiting absorption and desorption isotherms. The most common and important source of RH fluctuations in a sorption jar is probably fluctuations in temperature. If the temperature changes rapidly the air in the jar will not have time to stay in equilibrium with the salt solution. A rapid temperature increase from 20 to 21°C will cause the RH of a saturated NaCl solution to drop from 75 to 71% RH. A second effect is the temperature dependence of the RH of the saturated salt solutions. For some salts (NaCl) this effect is very small, but for others (e.g.,  $\text{Mg}(\text{NO}_3)_2$  and  $\text{KNO}_3$ ) it is more important. NaCl has a temperature coefficient of 0.03%(RH)/K, whereas  $\text{Mg}(\text{NO}_3)_2$  and  $\text{KNO}_3$  have 0.30 and 0.18%(RH)/K, respectively.<sup>[9]</sup> Therefore the temperature should be kept constant or at least only allowed to change slowly.

Regarding the unsaturated aqueous solution another source of RH variations is the change in concentration. For a 2 molal NaCl solution a 2% increase in concentration will give a decrease in RH from 93.2% to 93.0% when interpolating between vapor pressures given as function of concentration by Clarke and Glew.<sup>[12]</sup> Regarding the sensitivity in RH for changes in temperature a slow increase from 20 to 25°C will only give a decrease from 93.2 to 93.1% in RH determined from partial vapor

pressures and saturated vapor pressures for each temperature given by Clarke and Glew.<sup>[12]</sup>

The seal in the lid of sorption jar is not perfect. We have tested the sorption jars by charging them with a drying agent (0.4 nm molecular sieves) in the sample pans only and keeping them in a room with 30% RH. The measured leakage was about 10 and 1 mg per 24 h for a light sample (8 g) and a heavy sample (28 g), respectively. A heavier sample will press the rubber tubing against the washer and the washer against the lid, and will thus reduce the leakage. When a sample of low mass is used it is therefore advantageous to add some extra mass, e.g., a stainless steel weight to reduce the leakage, as was done in the test measurements.

A leakage of 1 mg/day may seem to be quite high compared to the mass changes of the samples, but the error caused is negligible because of the very much higher capacity for absorption/desorption by the saturated salt solution than by the sample. The saturated salt solutions have sorption isotherms that are vertical, e.g., the RH does not change when the water content changes. The same is true for good drying agent. Normal samples have sorption isotherms with a limited slope. Consider a sample at equilibrium with the saturated salt solution. If water vapor that leaked into the sorption jar would be absorbed by the sample, the RH of the sample would increase. Then the sample would have a higher RH than the saturated salt solution and this would lead to a flow from the sample to the salt solution and a restoration of the original equilibrium.

We have further studied this problem by making finite element computer simulations with FEMLAB (Comsol, Stockholm, Sweden). For the case with a RH difference of 50% between the jar and the room a leakage of 1 mg/24 h through the seal changes the RH of the sample (at worst case stationary conditions with perfectly stagnant air in the jar) by less than 0.04%. This is less than the total uncertainty of the RH in the sorption jars. However, if the leakage is much higher than 1 mg/24 h it will be difficult to accurately know the RH in the jars.

The method with glass jars have been used to measure equilibrium sorption isotherms. In principle the method could also be used to follow transient mass changes, e.g., to determine mass transport coefficients, but the rather large mass transfer resistance between the sample and the vapor surface/sink may influence such results considerably.

One advantage with the present technique is that one can easily move a lid with a sample from a jar with one salt solution to another jar with another salt solution. It is also possible to dry the samples



in the jars to get the dry mass. Drying could either be with a drying agent or at 105°C. In the latter case the lid with the sample has of course to be opened, but at the end of the drying the lid can be closed and the dry mass determined. If the jar is insulated it is quite possible to make this weighing while the sample is still warm. As long as hot air from the warm jar does not disturb the balance we have found that we can make a measurement on a warm sample directly after ending the drying. A correction for the buoyancy of the sample may be needed.

## CONCLUSIONS

We have developed an experimentally simple yet good device to measure sorption isotherms in which a sample is kept inside a glass jar during the whole measurement period. The following details should be kept in mind for the method to be accurate:

- The leakage will be minimized if the lid of the jar and the washer are perfectly flat.
- The tubing should be cut perpendicular to its length direction.
- The mass of the sample should be increased with a dummy mass if the sample itself is light.

## ACKNOWLEDGMENTS

We thank Bengt Nilsson and Natalia Markova for their help with previous versions of this method. This research was funded by FORMAS (LW, KS) and the Swedish Nuclear Fuel and Waste Management Company (AD).

## REFERENCES

1. Wolf, W.; Spiess, W.E.L.; Jung, G. The water-vapour sorption isotherms of microcrystalline cellulose (MCC) and purified potato starch. Results of a collaborative study. *J. Food Eng.* **1984**, *3*, 51–73.

2. Arlabosse, P.; Rodier, E.; Ferrasse, J.H.; Chavez, S.; Lecomte, D. Comparison between static and dynamic methods for sorption isotherm measurements. *Drying Technol.* **2003**, *21* (3), 479–497.
3. Caro, Y.; Pina, M.; Turon, F.; Guilbert, S.; Mougeot, E.; Fetsch, D.V.; Attwood Graille, P.J. Plant lipases: biocatalyst aqueous environment in relation to optimal catalytic activity in lipase-catalyzed synthesis reactions. *Biotechnol Bioeng.* **2002**, *77* (6), 693–703.
4. Hébrard, A.; Oulahna, D.; Galet, L.; Cuq, B.; Abecassis, J.; Fages, J. Hydration properties of durum wheat semolina: influence of particle size and temperature. *Powder Technol.* **2003**, *130*, 211–218.
5. Leisen, J.; Beckham, H.W.; Benham, M. Sorption isotherm measurements by NMR. *Solid State Nuclear Magnetic Resonance.* **2002**, *22*, 409–422.
6. Markova, N.; Sparr, E.; Wadsö, L. On application of an isothermal sorption microcalorimeter. *Thermochim Acta* **2001**, *374*, 93–104.
7. Gustafsson, R.J.; Hall, G.E. Equilibrium moisture content of shelled corn from 50 to 155 F. *Trans. Am. Soc. Agric. Eng.* **1974**, *17* (1), 120–124.
8. Zuritz, C.; Singh, R.P.; Moini, S.M.; Hendersson, S.M. Desorption isotherms of rough rice from 10°C to 40°C. *Trans. Am. Soc. Agric. Eng.* **1979**, *22*, 433–444.
9. Greenspan, L. Humidity fixed points of binary saturation aqueous solutions. *J. Res. NBS A.* **1977**, *81* (1), 89–96.
10. Wadsö, L. Describing non-Fickian water-vapor sorption in wood. *J. Mater. Sci.* **1994**, *29*, 2367–2372.
11. Karnland, O.; Muurinen, A.; Karlsson, F. *Bentonite Swelling Pressure in NaCl Solutions—Experimentally determined data and model calculation*. Proceedings from Sitges Symposium on large scale field tests in granite. November 12–14, 2003. University of Catalonia, Spain. To be published by Balkema.
12. Clarke, E.C.W.; Glew, D.N. Evaluation of the thermodynamic functions for aqueous sodium chloride from equilibrium and calorimetric measurements below 154°C. *J. Phys. Chem. Ref. Data.* **1985**, *14* (2), 489–610.
13. Levoguer, C.L.; Williams, D.R. Characterizing materials by dynamic vapour sorption. *Pharm. Manuf. Rev.* **1997**, *9* (3), 2–3.
14. Kraehenbuehl, F.; Stoeckli, H.F.; Brunner, F.; Kahr, G.; Mueller-Vonmoos, M. Study of the water-bentonite system by vapour adsorption, immersion calorimetry and X-ray techniques: I. Micropore volumes and internal surface areas, following Dubinin's theory. *Clay Minerals.* **1987**, *22*, 1–9.

15. Kahr, G.; Kraehenbuehl, F.; Mueller-Vonmoos, M.; Stoeckli, H.F. *Wasserabnahme und Wasserbewegung in hochverdichtetem Bentonit*; Nagra: Baden, Switzerland, 1986.
16. McBain, J.W.; Bakr, A.M. A new sorption balance. *J. Am. Chem. Soc.* **1926**, *48*, 690–695.

**Performance of Edge Sealing Systems Used  
in Moisture Transport Experiments.**

Svennberg, K. and Segerholm, I. (2006).

Published in *Building Physics 2006*, ed. Paul Fazio,  
Proceedings of the 3<sup>rd</sup> International Conference in Building Physics  
(Montreal, Canada, 27-31 August 2006), Taylor & Francis, London.



# Performance of edge sealing systems used in moisture transport experiments

K. Svennberg

*Building Physics LTH, Lund University, Lund; Sweden*

I. Segerholm

*Chalmers University of Technology, Division of Building Technology, Building Materials Göteborg; Sweden*

**ABSTRACT:** Edge sealing is often used to assure one-dimensional moisture flow and a defined exposure area in various types of moisture transport experiments. This paper deals with the overall performance of a number of edge sealing systems – including wax-paraffin mix, epoxy adhesive, silicone and different tapes and films. The overall performance of the sealing systems includes vapor permeability and hygroscopicity, workability, thermal durability, flexibility, adhesion and risk of hydrophobation. The moisture-related properties are determined gravimetrically with the cup method and the JAR-method – a sorption method. The other properties are examined visually and qualitatively. Each of the properties of the edge sealing systems is rated using a graded rating from inadequate to excellent and the overall performance is an assessment of all the single properties. This comparative study shows that the best overall performance among the studied edge sealing systems were seen in the tapes and films. The mixes have not as good performance regarding workability and also demonstrate a higher risk of hydrophobation. The advantages as well as the disadvantages of each system are discussed together with some recommendations on usage.

## 1 INTRODUCTION

Several experimental methods concerning moisture transport require different types of sealing procedures. In some experiments, including sorption tests, the sealing is used to create a one-dimensional flow and to force a one-sided sorption. See Figure 1.

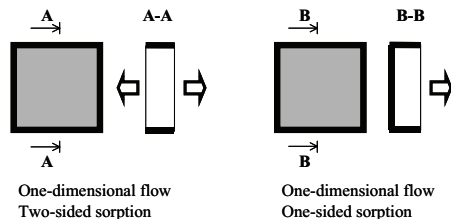


Figure 1. Applications of sealants in sorption experiments.

In other methods, such as cup method diffusion experiments, the sealant, besides creating a one-dimensional flow, is used to connect the material sample to the testing cup, as shown in Figure 2. An example of the use of the cup method can be studied in Siau (1984).

Edge sealing is also a measure used to define the exposed surface area in various experimental setups. The edge sealing system can also give a masking effect that needs to be considered in the evaluation of the experiment (Claesson, Hagentoft & Wadsö, 1994).

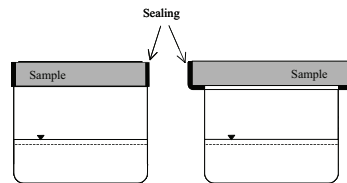


Figure 2. Applications of sealants in cup method experiments.

Regardless of the purpose, the performance of the sealants is rarely discussed. A thorough literature study turned up virtually nothing with reference to the overall performance of complete edge sealing systems. The need for a systematic evaluative study therefore seems evident and this paper offers a first attempt in that direction by presenting a basic comparison of the overall performance for a selection of edge sealing systems.

A number of properties need to be considered when choosing a sealant. The more obvious; vapor permeability, adhesion and hygroscopicity, can be evaluated using experimental methods commonly used in building science. These basic properties should be complemented with; workability, flexibility and thermal durability, all properties in which there are few commonly used methods.

The scope of the paper is to provide a qualitative assessment of the performance for a selection of edge sealing systems. There are in the market many similar sealing systems as the ones used in this study. The properties of the sample material, to

which the sealing system is applied, also vary; therefore the results presented in this paper should only be referred to for comparison.

## 2 SEALING SYSTEM

The principle of selection for the edge sealing systems in this study is simple; we choose to study the sealing systems that we have in one way or another used in our previous laboratory work. The seven different sealants vary, among other things, in chemical composition, durability, flexibility and mode of application. As far as possible we have tried to present the basic composition of the sealant together with specific manufacturer information.

### 2.1 Aluminum tape (*Alu*)

The aluminum tape is a 0.12 mm thick and 50 mm wide Permacel P-14 tape. The tape consists of a 0.11 mm thick aluminum foil with an acrylic based adhesive backing. The aluminum tape used does not have a liner, otherwise commonly used.

### 2.2 PVC-tape (*PVC*)

The PVC electrical insulation tape is a 0.20 mm thick and 19 mm wide ISOMAT PT 3900 tape. It consists of a PVC film and a rubber-based adhesive backing.

### 2.3 Thermoplastic laboratory film (*Parafilm*)

The laboratory film is a thermoplastic hydrocarbon wax film 0.13 mm thick and is manufactured under the brand name Parafilm. The film stretches easily, it clings to smooth surfaces and is also self-molding.

### 2.4 Butyl sticking strip (*Platon*)

The butyl sticking strip used in the study is 1 mm thick and 30 mm wide and manufactured by Isola-Platon. The strip will stick to most materials, even slightly damp, and stretches easily without tearing. It is also resistant to aggressive chemicals.

### 2.5 Epoxy adhesive (*Epoxy*)

The epoxy adhesive is manufactured by NM System and is mixed from 2 parts of epoxy resins and 1 part of hardener and is left to rest for 30 minutes before application. The epoxy adhesive is applied with a small plastic spatula. The thickness of the applied layer is 0.01-0.05 mm.

### 2.6 Silicone rubber (*Silicone*)

The silicone rubber is a one-component silicone polymer, manufactured by Akzo Nobel AB. It was applied with mastic gun and a plastic spatula. The final finish was accomplished by smoothing out using soap water. The thickness of the applied layer is 0.7-1.2 mm.

### 2.7 Beeswax-paraffin mix (*Beeswax*)

A mix of 50% beeswax and 50% paraffin wax is used. The wax-paraffin mix is first melted in a hot water bath and thereafter slightly cooled before applied with a small artists brush in an approximate thickness of 0.9-1.4 mm. Irregularities are smoothed out with a heated metal spatula.

## 3 EXPERIMENTS

When assessing the overall performance of the sealing systems we have chosen to take into account the vapor permeability and hygroscopicity, workability, thermal durability, flexibility, adhesion and risk of hydrophobation. Experimentally the moisture-related properties are determined gravimetrically with the cup method and the JAR-method. The other properties are examined visually and qualitatively.

### 3.1 Flexibility

The flexibility of the sealing systems was estimated by elongation tests. Both the elongation and the elastic ability were assessed.

#### 3.1.1 Method and materials

The elongation was estimated in a simple manner. Each sample material was cut in 10 cm pieces, one person manually pulled in each end of the sample piece until the piece broke. The elongation of the sample prior to breakage was measured with a metric scale.

The elasticity was assessed in a subjective way by observing the elastic dilatation from the elongation test and experience gained from handling the sealing systems in both the cup method and the JAR-method.

#### 3.1.2 Results

Table 1. Results from flexibility tests.

Material	Elongation (times original length)
Al-tape	Very inflexible
PVC-tape	2
Parafilm	3
Butyl sticking strip	15
Epoxy adhesive	Very inflexible
Silicone rubber	5
Beeswax- Paraffin mix	Inflexible

### 3.2 Risk for edge hydrophobation

In order to fasten to the surface of the specimen, the majority of edge sealing systems has a solvent-based adhesive or is applied in a fluid form. Due to this there is a risk that the sealing systems cause a hydrophobation on the edge either by solvents or the fluid penetrating the sample edge. This will be a concern mainly for small sample sizes where this edge effect will cause a major error in the estimated exposed area.

#### 3.2.1 Method and materials

The risk for edge hydrophobation was tested on 25 mm high, aerated concrete cylinders with a diameter of 48 mm. The cylinders were sealed on the edge with the different sealing systems. After 24 hours the sealing was exposed to an absorption experiment. The absorption experiment was done with water colored with methyl-blue, and the specimen was placed in the water for 15 minutes. After the absorption experiment each cylinder was divided and the penetration of water was estimated by judging the inking of the boundary area closest to the edge of the specimen.

#### 3.2.2 Results

None of the tape and film sealing systems showed risk of edge hydrophobation. An increased moisture load is observed at the edge for tape and film sealed specimen subjected to absorption experiments with fluid water. This is most likely due to capillary suction in the boundary between the tape or film and the specimen.

The silicone rubber, the epoxy and the beeswax/paraffin mix all showed some influence on the edge performance. The silicone rubber could easily be torn off the specimen and the surface that was exposed then was very smooth and “saturated” with silicone.

### 3.3 Thermal durability

In moisture experiments where edge sealing systems are used there is often a need for a dry weight or a completely dry material. This is commonly accomplished using elevated temperatures, e.g. 105 °C; therefore it is important to assess the durability or resistance to high temperatures of the sealing system.

#### 3.3.1 Method

One sample from each material was placed in aluminum sample pans and placed in a climate chamber with a temperature of 105 °C. After 1 and 5 hours, the samples were examined visually.

#### 3.3.2 Results

The results as presented in Table 2 from the thermal durability test show that only 2 materials (aluminum tape and epoxy adhesive) were intact after 5 hours. Silicone rubber and Butyl sticking strip were affected after 5 hours but still functioning. Beeswax cannot be said to have any thermal resistance at all, because of the low melting point. The time span of maximum 5 hours for the thermal durability test should be compared with the standard drying of samples for 24 h in 105 °C.

Table 2. Results from thermal durability test.

	1 hour	5 hours
Al-tape	Intact	Intact
PVC-tape	“Burned” in 2 spots	-
Parafilm	Soft (hard when cooled)	-
Butyl sticking strip	Intact	Sticky and with small blisters
Epoxy adhesive	Intact	Intact
Silicone rubber	Intact	Harder
Beeswax- Paraffin mix	Melted*	-

\* After approximately 5- 10 minutes

#### 3.4 Vapor permeability

Cup method measurements were used to assess the vapor permeability of the sealants (Segerholm 2002).

##### 3.4.1 Method and materials

The cup method is a well-documented method to investigate the moisture transport properties of materials. It is most commonly used for solid materials of some size such as wood, brick or concrete. See Figure 3.

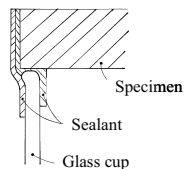


Figure 3. Cup design used for thick samples.

To use the method for thin samples of the sealants, as those presented above requires some modification. A carrier, on which the sealants can be applied, was necessary to ensure a plane surface. Ordinary cardboard, 0,3 mm thick, was chosen for this purpose and was also tested separately as a “dummy”. With the sealants applied to the cardboard, the cups were mounted according to the principle shown in Figure 4. Due to a misunderstanding, the cups testing aluminum, butyl sticking strip, beeswax and Parafilm were mounted using aluminum to fasten the samples to the cups and the remaining



four cups using butyl sticking strip. As the area of the gap covered by the sealant is much smaller than the total area of exposure, this mistake was not considered to have a major influence on the results. Glass cups filled with water with an inside diameter of 91 mm were used. The air-gap between the water surface and the sample was 35 mm.

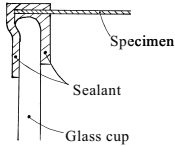


Figure 4. Cup design used for thin test samples

After mounting, the cups were placed in a climate room (20 °C, 50 %RH) and weighed regularly until steady-state conditions were achieved. The moisture fluxes were then calculated according to:

$$q = \frac{m_2 - m_1}{A \cdot \Delta t} \quad (1)$$

where  $q$  = moisture flux [ $\text{kg}/\text{m}^2 \cdot \text{s}$ ];  $m_2$  = the cup weight at  $t_2$  [kg];  $m_1$  = the cup weight at  $t_1$  [kg];  $A$  = area of sample [ $\text{m}^2$ ];  $\Delta t$  = time between  $t_2$  and  $t_1$  [s].

The moisture flux is defined as positive going out of the cup.

### 3.4.2 Results

The results of the cup method measurements are presented in the form of moisture fluxes. It is perfectly possible to evaluate different moisture transport coefficients from the data, but in a comparative study such as this, the moisture fluxes are sufficient.

To assess the moisture fluxes, steady-state flow conditions are required. In Figure 5, a selection of the materials tested is shown.

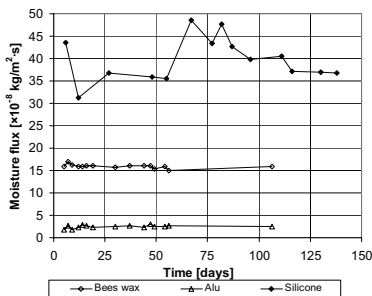


Figure 5. Flux development for selection of materials.

A horizontal shape of the graphs indicates steady-state conditions. The silicone rubber, which was started considerably later than the others, shows a bit of variations. Together with the PVC-tape and the epoxy adhesive, it will be monitored further to make sure the conditions indeed are steady state.

The moisture fluxes for all the sealants as of August 18, 2005, can be studied in Figure 6. The cardboard tested alone, as a “dummy”, gave a moisture flux of  $150 \times 10^{-8} \text{ kg}/\text{m}^2 \cdot \text{s}$ , and was left out of the diagram.

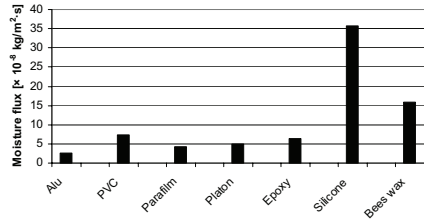


Figure 6. Moisture fluxes in the tested sealants.

The silicone rubber and the beeswax/paraffin mix stand out with higher fluxes. These two materials are also the most difficult to apply evenly and without cracks or cavities. The risk of leakages must therefore be considered in the evaluation.

### 3.5 Hygroscopicity

The hygroscopicity or moisture uptake was tested through sorption experiments.

#### 3.5.1 Method and materials

The sorption experiments employ the JAR-method where the specimen is kept in the desired ambient climate throughout the gravimetric determination of the moisture uptake. This is achievable through the design of the lid on the glass jars used as small climatic chambers (Svennberg and Harderup 2002; Wadsö, Svennberg et al. 2004). Also see Figure 7. The relative humidity (RH) in the glass jar is generated with saturated salt solutions ( $\text{KNO}_3 - 95 \% \text{RH}$ ,  $\text{K}_2\text{SO}_4 - 98 \% \text{RH}$ ).

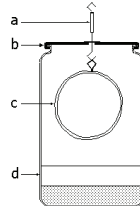


Figure 7. Experimental set-up for the JAR-method. a) The hook through the lid enabling gravimetric determination with sample in desired climate. b) The vapor-tight lid. c) The sample. d) The saturated salt solution used for generating desired RH.

The sealing systems were applied on two sample materials – wood with longitudinal flow along the fiber grain and aerated concrete. The specimens were cut into circular shape ( $\phi = 48 - 54$  mm). Both flat sides of the specimens were coated with aluminum tape and the sealing systems were applied on the edges of the specimens.

In test series 1 aluminum tape, Parafilm and beeswax/paraffin mix were tested on wood samples. The specimens were first put into a dry chamber (using molecular sieves (0.4 nm). The samples were thereafter put in climate chambers with a RH of 95 %.

In test series 2 aluminum tape, Parafilm, butyl sticking strip, beeswax/paraffin mix epoxy adhesive and silicone rubber were tested on wood and aerated concrete samples. The specimens were dried as in test series 1 but in the moisture absorption step they were placed in climatic chambers with a RH of 98 %.

In test series 3 PVC-tape was applied on glass plates and thereafter the specimens were placed in climatic chambers with a RH of 95 % for one day.

### 3.5.2 Results

The result of the sorption measurements is presented as the weight change for three different times and is calculated as a percentage of the initial weight of the complete specimen, including both backing material and sample material.

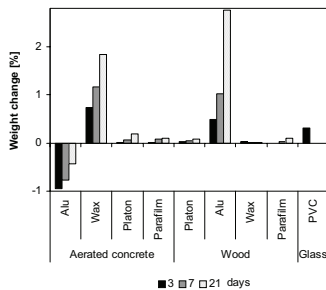


Figure 8. Results from sorption experiments performed with the JAR-method. Aerated concrete, wood (longitudinal grain) and glass were used as backing sample material. The result for the PVC refers to the weight change after 1 day.

The most conspicuous result is the weight change over time for the aerated concrete sample sealed with aluminum tape. This is most likely due to conditioning error giving a sample material with moisture content higher than the equilibrium moisture content for RH 98%.

## 4 EVALUATION

The sealing systems were evaluated separately, considering the different properties that were tested.

Two additional properties, workability and adhesion were evaluated according to the experience of the authors. Each of the properties of the edge sealing systems is rated using a graded rating from “inadequate” to “excellent” and the overall performance is an assessment of all the single properties.

Table 3. Definition of rating scale.

Rating	Symbol
Inadequate	---
Bad	--
Poor	-
Fair	+
Good	++
Excellent	+++

### 4.1 Aluminum tape (Alu)

The Alu receives a rating of excellent in vapor permeability and inadequate in flexibility. Both hydrophobation and thermal resistance properties are also excellent, while workability receives a rating of good and adhesion one of fair. It should be noted that the adhesion rates are higher for smooth and even surfaces. In the sorption test, the Alu rates poor. A summary of the ratings can be studied in Table 4

This system can be used in both cup method and sorption experiments, although the adhesion and poor flexibility can cause problems with materials with large moisture dimension changes, such as wood.

Table 4. Summary of assessed properties for aluminum tape.

Aluminum tape	
Flexibility	---
Hydrophobation	+++
Thermal durability	+++
Vapor permeability	+++
Hygroscopicity	-
Workability	++
Adhesion	+

### 4.2 PVC-tape (PVC)

The PVC’s most advantageous properties are workability and hydrophobation, which are rated excellent. It has low vapor permeability and good adhesion. Flexibility and sorption properties receive a fair rating while thermal resistance receives one of poor. See summary in Table 5.

The system works fairly well for both cup method and sorption measurements, but as with aluminum tape, the flexibility and adhesion properties can cause problems with materials like wood. The PVC can also be a good complement to other sealing systems, for example butyl sticking strip.

Table 5. Summary of assessed properties for PVC-tape.

	PVC-tape
Flexibility	+
Hydrophobation	+++
Thermal durability	-
Vapor permeability	++
Hygroscopicity	+
Workability	+++
Adhesion	++

#### 4.3 Thermoplastic laboratory film (Parafilm)

The best feature of the Parafilm is the hydrophobation property that receives a rating of excellent. Vapor permeability, hygroscopicity, flexibility and workability are all rated good, while thermal resistance is rated poor. Adhesion, as can be seen in Table 5, is rated fair. It should be pointed out that the adhesion to the surface of a material is rather poor. The “fair” rating comes from the self-molding ability of the Parafilm; that is, its ability to adhere to itself.

The Parafilm is useful for sorption experiments, but its adhesion properties are not suitable for cup method experiments. It is flexible enough to be used on most building materials, provided it is not stretched too much.

Table 5. Summary of assessed properties for thermoplastic laboratory film.

	Parafilm
Flexibility	++
Hydrophobation	+++
Thermal durability	-
Vapor permeability	++
Hygroscopicity	++
Workability	++
Adhesion	+

#### 4.4 Butyl sticking strip (Platon)

Platon receives a rating of excellent concerning flexibility, hydrophobation and adhesion and good in vapor permeability and hygroscopicity. The downside of the system lies in the thermal resistance and the workability, both rated fair. However, the low rating in workability is a direct result of the very high rating in adhesion; the material is incredibly sticky. In Table 6, a summary of the properties is shown.

This system is very versatile; it can be used with almost any material and it is suitable for both cup method and sorption experiments. Due to its stickiness, it is recommended to be used together with some other type of tape, for example Alu or PVC. Platon is at its best with materials like wood, when flexibility is essential.

Table 6. Summary of assessed properties for Butyl sticking strip.

	Platon
Flexibility	+++
Hydrophobation	+++
Thermal durability	+
Vapor permeability	++
Hygroscopicity	++
Workability	+
Adhesion	+++

#### 4.5 Epoxy adhesive (Epoxy)

Epoxy is rated excellent on thermal resistance and adhesion, but also inadequate in the flexibility test. Workability rates poor, but the overall impression is lifted with a good rating in vapor permeability and a fair rating in hydrophobation.

This system is mostly used for edge sealing of materials that are particularly difficult to deal with, for example plasterboard. It can be used for sorption experiments and possibly, together with another sealing system, for cup method experiments. The good adhesion and the poor flexibility make the system most useful with materials with very small moisture dimension changes. Its toxic fumes, however, makes it unpopular in many laboratories. The summary of the ratings can be seen in Table 7.

Table 7. Summary of assessed properties for epoxy adhesive.

	Epoxy
Flexibility	---
Hydrophobation	+
Thermal durability	+++
Vapor permeability	++
Hygroscopicity	
Workability	--
Adhesion	+++

#### 4.6 Silicone rubber (Silicone)

Silicone is rated poor concerning vapor permeability, hydrophobation and workability. Possibly the poor workability, which makes it difficult to spread an even, tight layer of the Silicone, affected the cup method measurements. The flexibility, thermal resistance and adhesion all receive a good rating.

With good adhesion and flexibility, Silicone can be used with almost any building material. However, the poor workability and the uncertainty regarding permeability make it less suitable for cup method and sorption experiments. The system is best used for crude sealings, for example on end grains of wooden studs subjected to heavy moisture loads. In Table 8, a summary of the evaluated properties of Silicone can be studied.

Table 8. Summary of assessed properties for silicone rubber.

Silicone	
Flexibility	++
Hydrophobation	-
Thermal durability	++
Vapor permeability	-
Hygrosopicity	
Workability	-
Adhesion	++

#### 4.7 Beeswax-paraffin mix (Beeswax)

Beeswax received fair ratings for permeability, sorption, hydrophobation, workability and adhesion. On the other hand, it has no thermal resistance to speak of and almost no flexibility, both rated inadequate. Table 9 shows the summary of the ratings for Beeswax.

This system is almost exclusively used for cup method experiments, using cups with a fold, like the one on the right in Figure 2 above. In this application it works very well, except with materials like wood, where moisture dimension changes (in this case usually warping) will cause the Beeswax to crack and leak.

Table 9. Summary of assessed properties for beeswax-paraffin mix.

Beeswax	
Flexibility	---
Hydrophobation	+
Thermal durability	---
Vapor permeability	+
Hygrosopicity	+
Workability	+
Adhesion	+

## 5 DISCUSSION

Different sealing systems are suitable for various purposes; it is therefore difficult to compare them. Sample materials as well as experimental procedures are of importance when choosing sealing system. From our point of view the best overall performance among the studied sealing systems were seen in the "tape and film group" including aluminum tape, PVC-tape, butyl sticking strip and the thermoplastic laboratory film. The other three sealing systems, epoxy adhesive, silicone rubber and beeswax-paraffin mix, fail to reach acceptable standard regarding flexibility and workability. These three sealing systems also show a higher risk for hydrophobation of the sample edge. Only one system, aluminum tape, continued functioning during the high temperature test (105 °C).

The study presented here is a first attempt to evaluate different edge sealing systems. All experi-

mental work was performed without duplicates and further research is proposed to verify these findings. Such a study could lead to guidelines concerning testing and which sealing system to use for specific materials and experimental procedures. In addition proper material properties for the studied sealing systems could be obtained.

From this limited study we can conclude that when designing an experiment, the choice of sealing system should be carried out with great concern and necessary properties of the sealing system should be carefully evaluated. It is equally important to make adequate predictions regarding the behavior of the tested materials in connection with the chosen experimental procedure and sealing system.

## REFERENCES

- Claesson, J., C.-E. Hagentoft, et al. (1994). "Masked Edge Effects When Measuring Diffusion Coefficients With the Cup Method." *Polymer Engineering and Science* 34(10): 821-826.
- Segerholm, I. 2002. Moisture transport in wood exposed to a temperature gradient. An experimental method. *Proceedings of the 6<sup>th</sup> Symposium on Building Physics in the Nordic Countries*, Trondheim, Norway, June 17-19, pp 365-371.
- Siau, J. S. 1984. *Transport processes in wood*. Springer-Verlag, Berlin
- Svennberg, K. & Harderup, L-E. 2002 Time-dependent moisture properties for plasterboard with surface coating. *Proceedings from Indoor Air 2002*, Monterey, California, USA.
- Wadsö, L., Svennberg, K. Et al. 2004. An experimentally simple method for measuring sorption isotherms. *Drying Technology* 22(10): 2427-2440.



**Sorption Isotherms for Textile Fabrics, Foams  
and Batting Used in the Indoor Environment.**

Svennberg, K. and Wadsö, L.

Submitted to the *Journal of the Textile Institute*.



# Sorption Isotherms for Textile Fabrics, Foams and Batting Used in the Indoor Environment

Kaisa Svennberg\*

Building Physics LTH and the Moisture Research Centre at Lund University, Sweden

Lars Wadsö

Building Materials LTH, Lund University, Sweden

## ABSTRACT

An increasing interest in the moisture buffering of indoor surface materials and new tools for calculation of energy demands and indoor climate calls for relevant material properties of all materials exposed to the indoor air. Textile fabric represents a large portion of the surface materials present in dwellings and offices and is therefore of special interest. This paper presents the sorption isotherms for nine fabrics, two foams and one batting, all of material compositions that are commonly found in the indoor environment. The data are fitted to the Hailwood-Horrobin sorption isotherm equation and good agreement is found for all materials. The difference in moisture capacity and hysteresis between different materials is discussed.

KEY-WORDS: sorption isotherm, textile fabric, indoor environment

---

\* Corresponding author: Kaisa Svennberg, Building Physics LTH, Lund University, Box 118, 221 00 LUND, Sweden. e-mail: [kaisa.svennberg@byggtek.lth.se](mailto:kaisa.svennberg@byggtek.lth.se)



## Introduction

Today there is an increasing interest in moisture buffering in the indoor environment from not only traditional building materials, but also furniture and furnishing. With new tools for energy calculations and hygrothermal calculations of for example indoor temperature and mold risk, there is a need for material properties of all materials exposed to the indoor air. As textiles, as shown in Table I, represent a significant part of the exposed area in dwellings we need moisture related material properties for such materials suitable for building physical calculations [8, 16]. A climatic chamber study by Svennberg et al. [17] showed that the amplitude of the daily moisture variations were decreased with 10-15% RH when a fully furnished room, including upholstery, carpets, books and paper, was compared to an empty room, see Fig.1. These results are in accordance with results reported by e.g. Plathner and Woloszyn [13]. Material properties of textiles, foams and batting are also needed for simulations of moisture conditions in beds, upholstered furniture and other house dust mite habitats, an area of increasing scientific interest during the recent years [14, 20, 21, 22], as mite allergy is an growing problem in many countries.

The aim of this study is to determine the equilibrium sorption properties (sorption isotherms) of some textile fabrics, battings and foams used in the indoor environment. Traditionally, sorption properties are determined for textile fibers and not for complete fabrics and numerous studies have been made for various types of textile fibers, e.g.[3, 18, 19, 23]. For all materials the sorption isotherm is a bulk property, i.e., a sorption isotherm measured on a small part of a sample can be used for larger pieces of material as long as the material is homogeneous. However, there may be differences in sorption properties between the fibers used to make a textile fabric and the final product, as the textile making process may involve mechanical treatment, coating, dyeing etc., which can influence the fiber properties. To obtain relevant material properties for textiles used in the indoor environment it is therefore preferable to determine the sorption properties for textiles in the final manufactured state. In this paper the sorption isotherms for two upholstery foams, a wool batting and nine textile fabrics, all typical for the indoor environment, are presented.

## Methods

A sorption balance (DVS 1000, Surface measurements Systems, London, UK) was used to determine sorption isotherms for the indoor materials. This type of instrument is mainly used for studies of pharmaceutical materials [4], but it has also been used to determine sorption isotherms for cement based building materials[1], food-stuffs [9], and sewage sludge [2]. The sorption balance is described in Fig. 2. In the present measurements the samples were exposed to an initial drying and then to the following constant relative humidities: 10-20-30-40-50-60-70-80-90-95-90-80-70-60-50-40-30-20-10-0%. A weight change of less than 0.002% per min was chosen as the equilibrium criterion at each RH level before proceeding to the next RH level.

From each of the nine fabrics a circular sample 20 mm in diameter was used. The two foams and the batting were cut into sample cubes, each side being approximately 10 mm. The samples were either placed in a standard glass pan (A) or hanged in the gas stream from a metal wire (B). The type of suspension for each measurement is indicated in Table II.

## Materials

Two foams and one batting used for upholstery, and nine textile fabrics were studied. The fabrics varied from a thin cotton-polyester curtain material to a thick felted wool furnishing fabric. Five of the fabrics were wool based furnishing fabrics used for upholstered furniture; the other four fabrics were cotton based textiles for soft furnishing applications. The foams were cold cured polyether foams, one highly viscoelastic and one regular, both used for mattress and upholstery. The batting was wool batting used for overlay mattress. Table II gives thickness, density material composition and weaving technique, where relevant, of the tested materials.

## Results

The sorption isotherms were plotted with the equilibrium moisture content for absorption and desorption,  $u_{\text{abs}}$  and  $u_{\text{des}}$ , for each RH respectively. The Hailwood-Horrobin sorption isotherm equation [7], Eq. 1, was applied both for absorption and desorption:

$$u = \frac{\varphi}{A + B \cdot \varphi - C \cdot \varphi^2} \quad (1)$$

Here  $u$  (g/g) is the moisture content (g H<sub>2</sub>O/g dry material) and  $\varphi$  (Pa/Pa) the relative humidity.  $A$ ,  $B$  and  $C$  are fitting parameters for the Hailwood-Horrobin sorption isotherm equation.

The Hailwood-Horrobin sorption isotherm equation was developed for polymer fibers, but is today mainly used in wood science [11, 15]; it can generally be used for the whole RH range. We found good agreement for all the tested materials and that the Hailwood-Horrobin equation is a convenient equation for fitting sorption isotherms of textiles. The Hailwood-Horrobin fitting parameters for the tested materials are given in Table III.

It should be noted that the Hailwood-Horrobin equation (Eq. 1) is mathematically equivalent to e.g. the Dent sorption equation [6], but the Hailwood-Horrobin equation assumes formation of both hydrate and solid solution, whereas the Dent equation is based on a theory of multilayer sorption. These mathematically equivalent sorption equations are thus based on quite different assumptions and one should avoid using a good fit to a sorption equation as a proof of the correctness of the underlying assumptions. We therefore view the Hailwood-Horrobin equation only as a convenient fitting equation.

Figures 3-7 show the sorption isotherms for the polyether foams (Fig. 3), the cotton-based soft furnishing textiles (Fig. 4), the synthetic soft furnishing textiles (Fig. 5) and the wool-based furnishing fabrics (Fig. 6-7). The Hailwood-Horrobin sorption isotherm curve fits are given for most materials. Note that the Figs. 3-7 differ in y-axis ranges.

The hysteresis ratio  $H$  between absorption and desorption isotherms was evaluated by Eq. 2 [12]:

$$H = \frac{u_{des} - u_{abs}}{u_{abs}} \quad (2)$$

The hysteresis ratios for the majority of the tested materials are shown in Fig. 8.

## Discussion

The two foams have significantly different sorption behavior. The regular polyether foam has a low moisture uptake and shows no hysteresis. It is also the only material in this study that doesn't have a sigmoid sorption isotherm curve, as it is linear up to 25% RH. The highly viscoelastic polyether foam shows a higher moisture uptake compared to the regular and a small but noticeable hysteresis effect, Fig. 3.

The cotton-based and synthetic textiles for soft furnishing show similar sorption isotherms with the exception of the 100% polyester fabric that has a low moisture uptake and no hysteresis, Fig. 5. The cotton-based and synthetic fabrics have, as expected, a lower moisture uptake than the wool based fabrics, Figs. 4, 5 and 6.

The highest equilibrium moisture content at high RH was found for the 50% viscose-50% wool fabric, followed by the pure wool fabrics and the wool fabric mixed with 15% polyamide, Fig. 6. In the lower RH regions the viscose-wool mix and the pure wool look very similar. The polyamide-wool mix had a slightly lower moisture uptake for the lower RH compared with the other two furniture fabrics. The three wool mixes show the expected differences since viscose fibers have higher and polyamide lower moisture capacity than the wool fibers [10]. The hysteresis of cotton-based fabric is smaller than the wool-based fabrics, Fig. 8.

The mix of wool and polyamide has a slightly lower hysteresis but show the same pattern as the other wool materials, with the largest hysteresis in the middle of the RH range and a decreasing hysteresis with higher RH, giving the lowest hysteresis effect at 90% RH. The pure wool fabric and wool batting all have very similar sorption isotherms. The largest differences are found in the higher RH regions, with the lower moisture contents for desorption found in the more open wool batting.

The impact of textile materials in the moisture buffering in an indoor environment comes from their often high moisture capacity and their rapid absorption and desorption of moisture compared with other surface materials exposed to indoor air. For diurnal variations in RH textiles are most likely close to equilibrium moisture conditions. They will therefore effectively dampen RH variations, whereas for example a painted wood or gypsum board will have too high resistance to moisture diffusion to influence the RH, as much as textiles, even if both these materials have high moisture capacity.

A complication when modeling sorption effects with materials showing hysteresis, is that the effective moisture capacity is considerably smaller than either of the absorption or desorption curves would suggest on their own. Sinusoidal RH variations will make the RH-moisture content trace a loop within the absorption-desorption boundaries. See Fig. 9 for an example of this effect measured on wood by Chomcharn and Skaar [5]. It is not known how much scanning loops due to RH-variations reduces the moisture buffering capacity of textiles in the indoor environment, but it does not eliminate the buffering effect, as is clearly seen in Fig.1.

## **Acknowledgements**

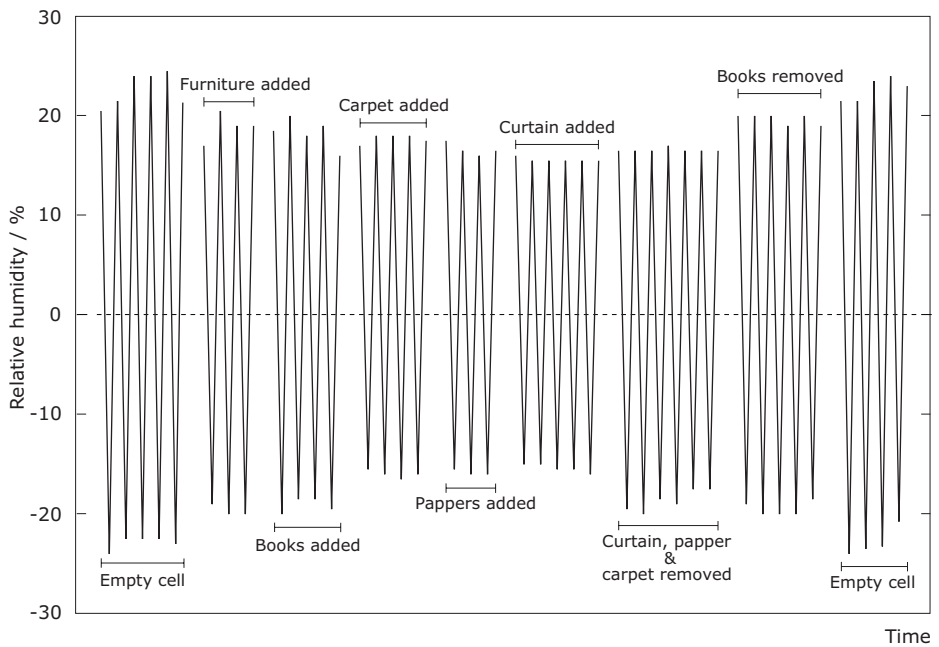
The support from Almedahls AB, IKEA of Sweden and Kinnarp AB is gratefully acknowledged. The work was carried out with financial support from FORMAS and SBUF.

## References

1. Anderberg, A. and Wadsö, L., *Moisture in Self-Levelling Flooring Compounds. Part Ii. Sorption Isotherms*. Nordic Concrete Research, 2004. **32**(2): p. 16-30.
2. Arlabosse, et al., *Comparison between Static and Dynamic Methods for Sorption Isotherm Measurements*. Drying Technology, 2003. **21**(3): p. 479-497.
3. Ashpole, D.K., *The Moisture Relations of Textile Fibres at High Humidities*. Proc. Royal Society of London. Series A. Mathematical and Physical Sciences, 1952. **212**(1108): p. 112-123.
4. Chan, H.-K., et al., *Physical Stability of Salmon Calcitonin Spray-Dried Powders for Inhalation*. Journal of Pharmaceutical Sciences, 2004. **93**(3): p. 792-804.
5. Chomcharn, A. and Skaar, C., *Dynamic Sorption and Hygroexpansion of Wood Wafers Exposed to Sinusoidally Varying Humidity*. Wood Sci. Technol, 1983. **17**: p. 259-277.
6. Dent, R.W., *A Multilayer Theory for Gas Sorption. Part I: Sorption of a Single Gas*. Textile Res. J., 1977(February): p. 145-152.
7. Hailwood, A.J. and Horrobin, S., *Absorption of Water by Polymers: Analysis in Terms of a Simple Model*. Trans. Far. Soc. B, 1946. **42**: p. 84-92.
8. Harderup, L.-E., *Luftfuktighet inomhus med hänsyn till icke-stationära fenomen. Sammanställning av publiceringar under perioden 1979-1998*. 1998, Building Physics, Lund University: Lund. p. 121.
9. Hebrard, A., et al., *Hydration Properties of Durum Wheat Semolina: Influence of Particle Size and Temperature*. Powder Technology, 2003. **130** (1-3)(Sp. Iss. SI 19): p. 211-218.
10. Morton, W.E. and Hearle, J.W.S., *Physical Properties of Textile Fibres*. 3rd ed. 1992, Manchester: The Textile Institute. 725.
11. Okoh, K.I.A. and Skaar, C., *Moisture Sorption Isotherms of the Wood and Inner Bark of Ten Southern U.S. Hardwoods*. Wood Fiber, 1980. **12**(2): p. 98-111.
12. Okubayashi, S., Griesser, U.J., and Bechtold, T., *A Kinetic Study of Moisture Sorption and Desorption on Lyocell Fibers*. Carbohydrate Polymers, 2004. **58**: p. 293-299.
13. Plathner, P. and Woloszyn, M., *Interzonal Air and Moisture Transport I a Test House. Experiment and Modeling*. Building and Environment, 2002. **37**: p. 189-199.

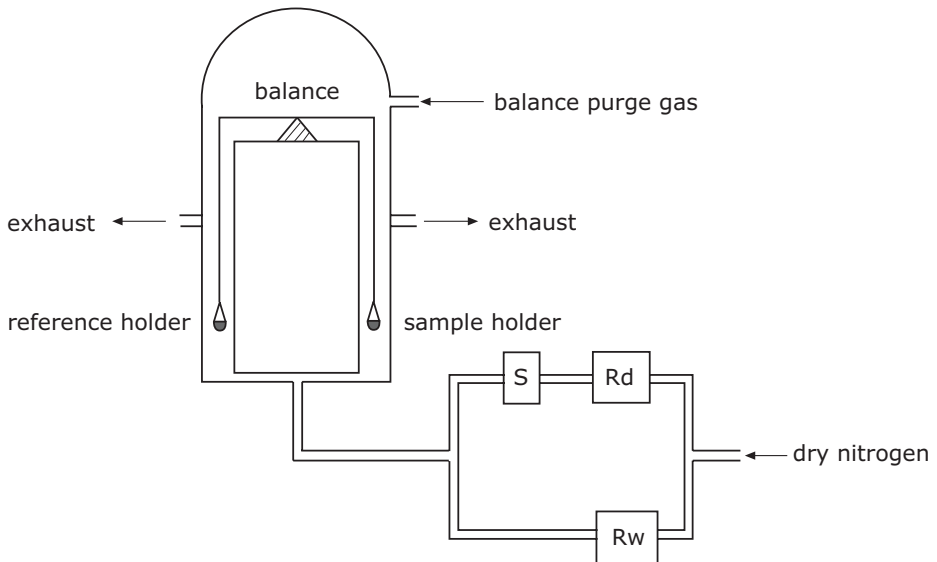
14. Siebers, R., Nam, H.-S., Crane, J., *Permeability of Synthetic and Feather Pillows to Live House Dust Mites and House Dust*. Clinical & Experimental Allergy, 2004. **34**(6): p. 888-890.
15. Skaar, C., *Wood-Water Relations*. 1988, Berlin: Springer-Verlag.
16. Svennberg, K., *Determination of Moisture Properties for Materials Exposed to the Indoor Air*. 2003, Lund: Department of Building Physics, Lund University.
17. Svennberg, K., Hedegaard, L., and Rode, C., *Moisture Buffer Performance of a Fully Furnished Room*, in *Whole Building Envelope IX*. 2004, ASHRAE: Clearwater Beach, FL.
18. Toner, R.K., Bowen, C.F., and Whitwell, J.C., *Equilibrium Moisture Relations for Textile Fibers*. Textile Research Journal, 1947(Jan): p. 7-18.
19. Üklü, S., et al., *A Study of Adsorption of Water Vapour on Wool under Static and Dynamic Conditions*. Adsorption, 1998. **4**: p. 63-73.
20. van den Bemt, L., et al., *Influence of Mattress Characteristics on House Dust Mite Allergen Concentration*. Clinical and Experimental Allergy, 2006. **36**: p. 233-237.
21. Vidal, C., et al., *High Prevalence of Storage Mite Sensitization in a General Adult Population*. Allergy, 2004 Apr. **59**(4): p. 401 - 5.
22. Wadsö, L. and Svennberg, K., *Bedrooms without House Dust Mites. Final Report from a Preliminary Study*. 2005, TVBH-7230. Building Materials and Building Physics: Lund.
23. Whitwell, J.C. and Toner, R.K., *Predicting Equilibrium Moisture Relations with Particular Reference to Textile Fibers*. Textile Research Journal, 1947(Feb): p. 99-108.

## Figures

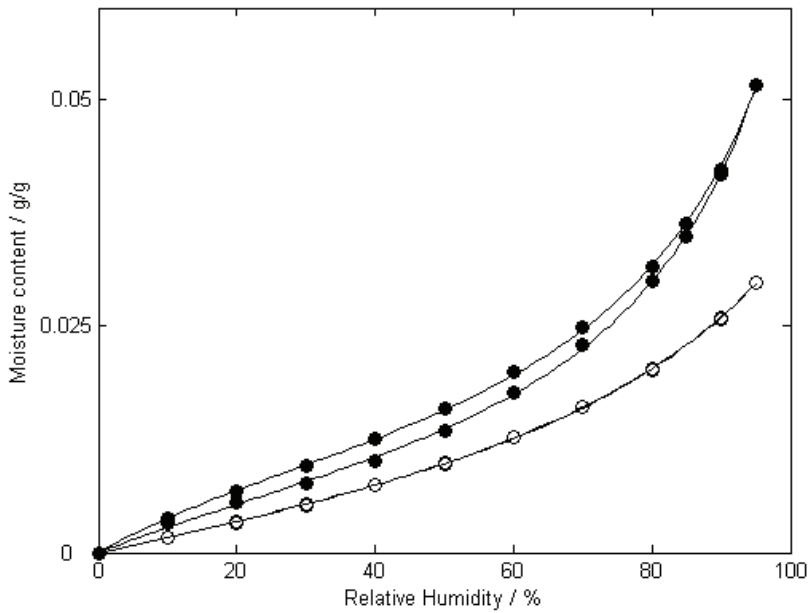


**Figure 1.** The variation in RH in a climatic chamber for nine different cases of furnishing, varying from an empty room to a fully furnished room and back to an empty room. The more furnishing materials, especially lightweight and permeable, the higher moisture buffering is seen for the room. The maximum dampening is found for the fully furnished room. The average RH for the experiments was 58 % RH (standard deviation 3.3% RH). Adapted from [17].

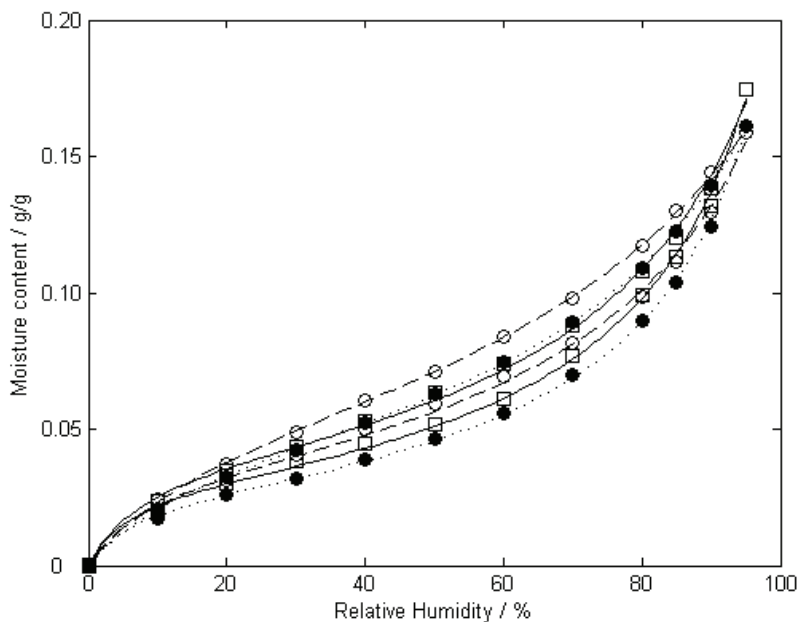




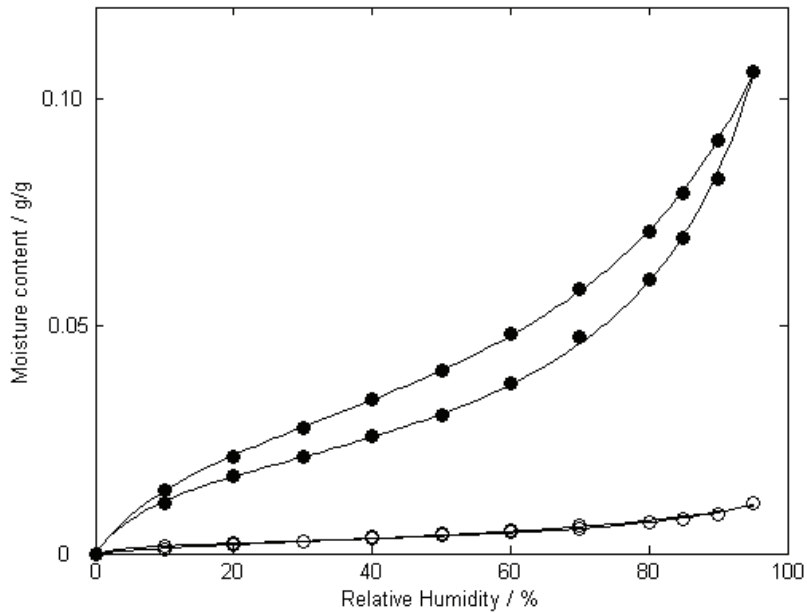
**Figure 2.** Schematic drawing of the DVS 1000 sorption balance. Two mass flow regulators (Rw and Rd) control the flow rate of two streams of dry nitrogen. The flow from Rw (wet) is saturated with water vapor by bubbling it through a bottle of water (S) and the other flow (Rd) is kept dry. The relative humidity (RH) is determined by the proportions of the total flow rate of 200 ml per min that flows through Rw and Rd. When the wet and the dry gas streams mix the wanted RH is generated and any RH between 0 and 98% can be generated. The mass of the sample is continuously measured by a Kahn 200 microbalance with a resolution of 0.1  $\mu\text{g}$ . The sample is placed in a small glass pan or hanged free in the gas stream. An empty pan is used as a reference. The DVS was programmed in steps for the sorption isotherm measurements. The system (except for the balance) is housed in a cooled incubator and the generated RH is within  $\pm 1.5\%$  RH judged from validation measurements with saturated salt solutions.



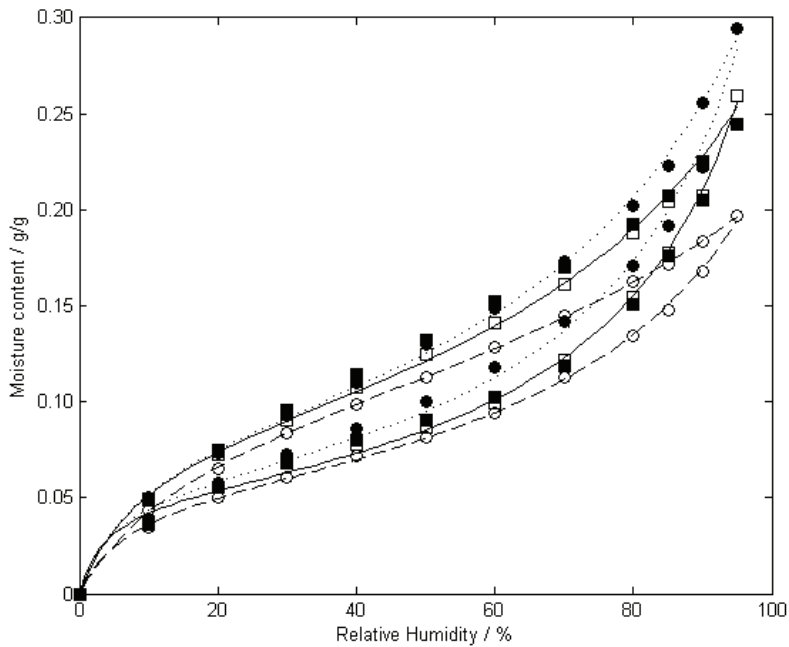
**Figure 3.** The sorption isotherm for cold cured polyether foams: (○) regular and (●) viscoelastic. The Hailwood-Horrobin sorption isotherms are shown with solid lines. Note the scale on the y-axis.



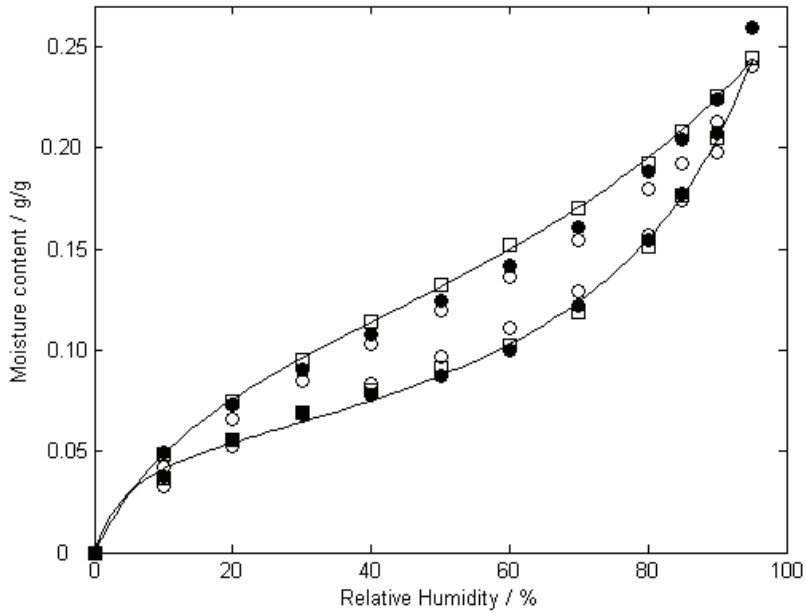
**Figure 4.** The sorption isotherms for: (○) 100% cotton bedding fabric, (●) 100% cotton curtain fabric and (□) 58% cotton – 42% flax fabric. The Hailwood-Horrobin sorption isotherms are shown with dashed line for the cotton bedding fabrics, dotted line for the cotton curtain fabric and solid line for the cotton-flax fabric.



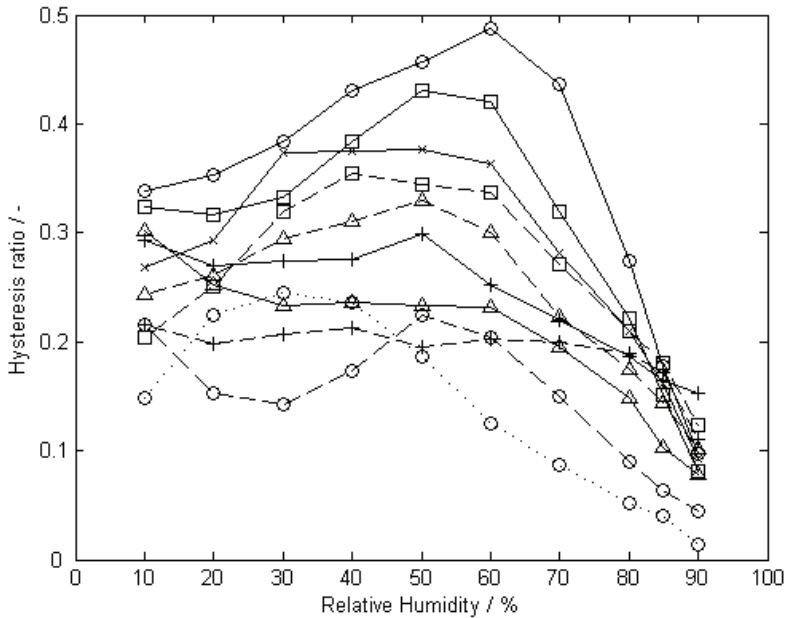
**Figure 5.** The sorption isotherms for: (○) 100% polyester fabric and (●) 59% cotton – 41% polyester. The Hailwood-Horrobin sorption isotherms are shown with solid lines. Note the scale on the y-axis.



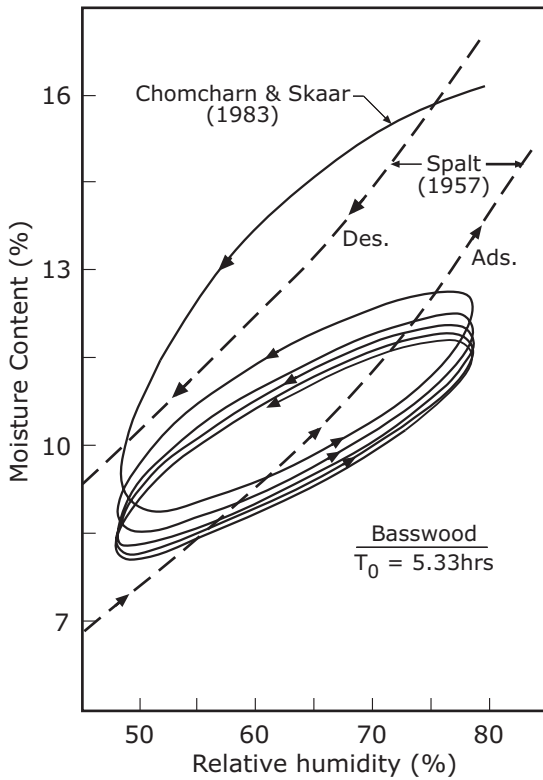
**Figure 6.** The sorption isotherms for the wool based fabrics: (○), 15% polyamide – 85% wool, (●)50% viscose – 50% wool, (□) 100% felted wool and (■) 100% plain wool . The Hailwood-Horrobin sorption isotherms are shown with solid line for the felted wool fabric, dashed line for the polyamide-wool fabric and dotted line for the viscose-wool fabric.



**Figure 7.** The sorption isotherms for the pure wool materials: (○) the wool batting, (●) plain wool fabric and (□) felted wool fabric. The Hailwood–Horrobin sorption isotherm for the felted wool fabric is shown with a solid line.



**Figure 8.** The hysteresis plotted against RH for: the wool based materials - solid lines [(○) felted wool fabric, (□) plain wool fabric, (+) viscose-wool fabric and (△) polyamide-wool fabric], cotton based materials - dashed lines [(○) cotton-flax fabric, (□) cotton curtain fabric, (+) cotton bedding fabric and (△) cotton-polyester fabric] and synthetic foam - dotted line [(●) viscoelastic polyether foam].



**Figure 9.** A scanning loop for wood due to sinusoidal RH-variations adapted from Chomcharn and Skaar [5]. Note that the scanning loop is not within the limits of the sorption isotherm; this might be due to that the sorption isotherm was measured on another sample of basswood or that the sample is not at equilibrium with the relative humidity. Scanning loops are normally expected to lie inside the limiting isotherms.



# Tables

**Table I. Surface materials exposed in dwellings. \***

Material	%
Wood - untreated	0.5
Wood - surface treated	14.6
Synthetic flooring	8.3
Wallpaper	33.4
Painted surfaces	20.8
Textile carpets	4.2
Textile furnishings	18.2

\* Based on an inventory of 16 rooms in six apartments in two buildings in the south of Sweden, total exposed area 1115 m<sup>2</sup>

**Table II. Thickness, density and material composition.**

Sample #	Material composition	Type of fabric	Field of application	Thickness (mm)	Density (kg/m <sup>3</sup> )
1 <sup>A</sup>	Polyether	Regular foam	Chair upholstery	31	36
2 <sup>A</sup>	Polyether	Viscoelastic foam	Overlay mattress	40	31
3 <sup>A</sup>	Wool	Batting	Overlay mattress	15	32
4 <sup>A</sup>	100% cotton	Plain weave	Curtain	0.40	563
5 <sup>B</sup>	100% cotton	Plain weave	Bedding	0.25	672
6 <sup>A</sup>	58% cotton - 42% flax	Plain weave	Curtain Table cloth	0.50	605
7 <sup>A</sup>	58% cotton 42% polyester	Plain weave with burn-out	Curtain	0.25	565
8 <sup>A</sup>	100% polyester	Plain weave	Curtain	0.30	610
9 <sup>A</sup>	50% viscose - 50% wool	Plain weave Yarns twisted	Furnishing fabric	1.1	346
10 <sup>A</sup>	15% polyamide - 85% wool	Jacquard weave	Furnishing fabric	1.0	313
11 <sup>A</sup>	100% wool	Plain weave	Furnishing fabric	1.0	313
12 <sup>B</sup>	100% wool	Felted	Furnishing fabric	2.5	176

A: the sample was placed in a glass sample pan.

B: the sample was suspended in a metal wire.

**Table III. Fitting parameters A, B and C in the Hailwood-Horrobin sorption isotherm equation for absorption and desorption.**

Sample #	Material	Absorption			Desorption		
		A	B	C	A	B	C
1	Polyether foam - regular	60.4	-6.74	24.3	60.2	-5.43	25.4
2	Polyether foam - viscoelastic	0.604	31.3	49.5	22.4	44.3	50.9
4	100% cotton (curtain)	2.74	30.9	28.9	3.31	16.9	14.9
5	100% cotton - bedding	2.53	22.5	19.7	3.04	13.4	10.9
6	58% cotton - 42% flax	1.98	28.9	26.5	1.95	22.4	19.5
7	59% cotton 41% polyester	4.69	44.1	41.6	4.73	27.6	24.3
8	100% polyester	29.6	360	313	68.4	212	199
9	50% viscose - 50% wool	0.849	15.7	13.7	1.01	9.93	7.94
10	15% polyamide - 85% wool	1.25	16.5	13.3	1.58	8.21	5.03
11	100% wool (plain)	0.727	18.2	15.8	1.04	9.85	7.36
12	100% wool (felted)	0.886	16.9	14.5	1.37	7.33	4.90



**Moisture Uptake in a Chair Seat as a Response to Daily RH Variations in the Indoor Air. Climatic Chamber Measurements and Calculations.**

Svennberg, K., Claesson, J. and Hansen Kielsgaard, K.

Submitted to *Building and Environment*.



# Moisture Uptake in a Chair Seat as a Response to Daily RH Variations in the Indoor Air Climatic Chamber Measurements and Calculations

**Kaisa Svennberg, Lic. Eng., M. Sc<sup>1</sup>.**

Building Physics LTH, Lund University, Sweden

**Johan Claesson, Prof., Ph.D.**

Building Physics LTH, Lund University, Sweden and Building Physics, Chalmers University of Technology, Sweden

**Kurt Kielsgaard Hansen, Ass. Prof. Ph.D,**

Dept. of Civil Engineering, Technical University of Denmark, Denmark

**KEYWORDS:** Moisture variations, indoor air, measurements, calculation model, upholstery, furniture, chair, felted wool

## **ABSTRACT:**

In the indoor environment there are a number of materials with potential to act as moisture buffers including both building materials and furnishing materials. For daily moisture variations in the indoor air furniture with upholstery can play an important role as moisture buffers. Material properties and calculation models describing the response to moisture variations in the ambient climate for these material combinations are limited. In this project the moisture properties for a chair seat with a wool fabric and plastic foam padding were determined. The moisture uptake in the chair seat was measured using small temperature and relative humidity sensors. A numerical calculation model describing the step-response as well as the response to ramp variations is described. A comparison between measurements and theoretical calculations was performed. The difficulties with determination of material properties for highly permeable materials are also discussed as well as suitable methods and special considerations.

---

<sup>1</sup> Corresponding author: Kaisa Svennberg, Building Physics LTH, Lund University, Box 118, SE-221 00 Lund, Sweden. E-mail: [kaisa.svennberg@byggtek.lth.se](mailto:kaisa.svennberg@byggtek.lth.se)

# 1 Introduction

Materials found in the indoor environment form a heterogeneous group with typical building materials together with furniture and furnishing materials. Several of the materials exposed to the indoor air have the potential to act as moisture buffers for diurnal moisture variations.

There are different ways to categorize the materials in the indoor environment; (Martin, 1986) suggested a division into slow and fast materials, (Plathner, 2002) described the furnishing materials as soft and hard. Textiles and upholstery are examples of soft furnishing materials and wooden furniture and hard flooring are examples of hard furnishing materials. (Svennberg, 2003) suggested that the materials should be divided into different categories depending on their basic moisture properties in varying timescales. A climatic chamber study (Svennberg, 2004) showed that furniture and furnishings including textiles and upholstery may play a significant role in moderating diurnal moisture variations. This paper presents results from a study of the moisture uptake in upholstery as a response to diurnal moisture variations in the indoor air. The objective was to measure the moisture uptake at different depths of the upholstery and to establish an analytical mathematical model taking into account a moisture capacity of the surface materials. In connection to this adequate material properties needed for the calculations was determined.

## 2 Materials

The measurements as well as the theoretical calculations were performed on a chair seat from an industrially manufactured office chair.

The chair seat consisted of a 5 mm plastic board, 31 mm polyether foam and a 2.5 mm felted wool fabric as a cover. The plastic board was covered underneath with a non-woven synthetic fabric. The chair seat in cross section with the placing of the RH- and temperature sensors is shown in Fig. 1 and the thickness and density of the materials used are given in Table 1.

## 3 Methods

### 3.1 Determination of moisture properties of the materials

The sorption isotherms as well as the water vapor resistances ( $Z$ ) were determined for the felted wool fabric and the polyether foam.

#### 3.1.1 Sorption balance

The sorption isotherms for the felted wool fabric and the polyether foam were determined using a sorption balance (DVS 1000, Surface Measurement Systems, London, UK (Anderberg, 2004)). The initial weights of the material samples were 57.7 mg and 21.2 mg respectively. The samples were initially dried in the instrument in dry nitrogen. The RH inside the instrument is generated with high precision by mixing dry and water vapor saturated nitrogen gas. Both absorption and desorption were determined in steps of 10% RH (Svennberg, 2005). The temperature during the experiment was 21 °C.

The diffusivity for the felted wool fabric was evaluated from the step-change measurements provided by the sorption balance measurements mentioned earlier. The mass change is plotted against the square root of time and gives an essentially linear curve for the initial part of the step. From this the diffusivity,  $D$ , can be evaluated using an evaluation method based on (Crank, 1975). The method is presented in detail by (Anderberg, 2004). From the diffusivity and the air speed the vapor resistance  $Z_t$  of the textile layer can be calculated.

#### 3.1.2 Cup method

The vapor resistance for the 31 mm polyether foam was determined using the cup method according to EN ISO 12572:2001 in two intervals of RH, i.e. 75-49% RH and 33-49% RH with the exceptions given below. The cup shown in Fig. 2 was used for the measurements. The specimen was fastened to a plexiglass ring by use of silicone mastic, and the plexiglass ring with the specimen was fastened to the cup by use of rubber sealing as the tightening top was screwed to the cup. Inside the cup a supplementary glass cup containing the saturated salt solution was placed. By use of this supplementary glass cup the air layer thickness inside the cup was 6 mm. The area of cross-section of flow path was 5000 mm<sup>2</sup>.

The 75% RH was generated using a saturated salt solution of NaCl and the 33% RH inside the cup by using a saturated MgCl<sub>2</sub> solution. In both cases the



ambient climate outside the cup was held at 23.4 °C and 48.8% RH, i.e. 49% RH. The average air velocity above the cups was 2.3 m/s and the average atmospheric pressure was 982 hPa during the measurements. The temperature and RH was used to calculate  $\Delta p$ , the vapor pressure difference between the inside and the outside of the cup. The vapor flux,  $q$ , was calculated using the weight change over time.

The measured water vapor resistance  $Z_m$  is primary the resistance in the specimen material itself  $Z_p$ , but also the surface resistances at the specimen surfaces  $Z_1$  and  $Z_2$  and the resistance in the air layer inside the cup  $Z_a$  must be taken into account. Refer Equation 1, which includes these resistances:

$$q = \frac{\Delta p}{Z_p + Z_1 + Z_2 + Z_a} = \frac{\Delta p}{Z_m} \quad (1)$$

The surface diffusion resistances  $Z_1$  and  $Z_2$  may be found by Lewis' law, and the diffusion resistance  $Z_a$  for an air layer thickness of  $L_a$  is  $Z_a = L_a / \delta_a$ , where  $\delta_a$  is the water vapor permeability (WVP) in air. An analogy to heat transfer calculations is used to find water vapor pressure  $p_{1s}$  and  $p_{2s}$  and the corresponding relative humidities  $\phi_{1s}$  and  $\phi_{2s}$  at the specimen surfaces when the different diffusion resistances  $Z_a$ ,  $Z_1$ ,  $Z_2$  and  $Z_p$  are known (Hansen, 1990). The KOPLYSE 3.0 program (Mullit, 1993) which calculates water vapor resistance  $Z_m$  without corrections and the resistance in the specimen material itself  $Z_p$  with corrections together with the corresponding relative humidities  $\phi_{1s}$  and  $\phi_{2s}$  at the specimen surfaces was used in the evaluation.

## 3.2 Chair seat measurements

The moisture uptake measurements of the complete chair seat were performed in a full-scale well-insulated and moisture- and air tight climatic chamber (the PASSYS cell), see Fig. 3. In the climatic chamber the chair seat was subjected to a ramp variation, 40%-70% RH.

The indoor humidification, that represents the moisture production of an inhabited room, was provided by evaporation of moisture from a reservoir of water heated by an electric coil. Humidity was withdrawn from the air by a dehumidifier draining into the same reservoir. The drying represents the removal of humidity from the room that would normally take place by ventilation. The water reservoir was suspended in a load cell, and the rates of humidification and drying was controlled according to a predefined schedule. Padfield (1998) has used the principle in a small (0.5 m<sup>3</sup>) test chamber in the laboratory. The climatic chamber is instrumented with sensors for measuring both the outdoor climate and the indoor conditions. The indoor relative humidity is measured with capacitive moisture sensors with an accuracy of

about  $\pm 2\%$  RH. Two small fans were placed on the floor in both ends of the test cell to ensure a well-mixed airflow.

Three combined temperature and relative humidity sensors (Vaisala HMP44) were applied on the chair seat for moisture uptake measurements. The accuracy for the sensors is 0.4 K for the temperature measurements and 2% RH for the RH measurements. The first sensor was placed on top of the felted wool fabric. The second sensor was placed on top of the polyether foam but under the felted wool fabric and the third and last sensor was placed under the polyether foam. The sensors were placed along the centerline of the chair seat but somewhat displaced so that interference from the other sensors was minimized, see Fig 1.

### 3.3 Analytical solution

The measured water vapor content in the textile and at different depth in the polyether foam will be compared to the analytical solution, where the diffusion in the foam is coupled to the textile layer with its moisture capacity and the imposed vapor content in the air above.

#### 3.3.1 Mathematical problem

The water vapor content  $v(x,t)$  shall satisfy the diffusion equation. The initial value at  $t = 0$  is  $v_{in}$ . The moisture flux is zero at the boundary  $x = L$ . We have

$$0 < x < L: \quad \frac{1}{D_m} \cdot \frac{\partial v}{\partial t} = \frac{\partial^2 v}{\partial x^2}, \quad v(x, 0) = v_{in}; \quad \left. \frac{\partial v}{\partial x} \right|_{x=L} = 0. \quad (2)$$

At the boundary  $x = 0$ , there is a textile layer with the moisture capacity  $C_{sm}$ . The moisture flow resistance to the outside air with the prescribed moisture content  $v_0(t)$  is  $Z_s$ . The moisture balance at the boundary  $x = 0$  becomes

$$C_{sm} \cdot \frac{\partial}{\partial t} [v(0, t)] = \frac{v_0(t) - v(0, t)}{Z_s} + \delta_v \cdot \left. \frac{\partial v}{\partial x} \right|_{x=0} \quad (3)$$

The two right-hand terms are the moisture fluxes from air and from the underlying material. We may multiply the equation by  $Z_s$ . The boundary condition then involves a time  $t_0 = C_{sm} \cdot Z_s$ , which is the decline time for the textile against air without flux from the underlying material. It also involves a length  $L_0 = Z_s \cdot \delta_v$ , which is a measure of the surface resistance  $Z_s$ .

The moisture content  $v_0(t)$  in the air varies in a "triangular" way between  $v_{in}$  and  $v_1$  with a time period  $t_p$ , see Fig. 4.

### 3.3.2 Superposition of ramp solutions

The solution  $v(x,t)$  may be obtained from a basic *ramp* solution by suitable superposition. This is described in detail in (Claesson, 2005). Let  $v_r(x,t)$  be the solution for a ramp function:

$$v_0(t) = \begin{cases} t & t \geq 0 \\ 0 & t < 0 \end{cases} \quad v_r(x,0) = 0 \quad (4)$$

The ramp solution starts from zero:  $v_r(x,0) = 0$ ,  $0 \leq x \leq L$ .

We use the transformation

$$v(x,t) = v_{in} + \frac{v_1 - v_{in}}{t_p} \cdot v'(x,t) \quad (5)$$

The solution during the first period  $0 \leq t \leq t_p$  (and for  $t < 0$ ) is now  $v'(x,t) = v_r(x,t)$ . In the next period  $t_p \leq t \leq 2 \cdot t_p$ , we have to subtract two times the ramp solution that starts at  $t = t_p$ :

$$v'(x,t) = v_r(x,t) - 2 \cdot v_r(x,t - t_p), \quad t \leq 2t_p \quad (6)$$

In the next period, we have to add  $2 \cdot v_r(x,t - 2 \cdot t_p)$ , and so on. In general we have:

$$v'(x,t) = v_r(x,t) + 2 \cdot \sum_{m=1}^M (-1)^m \cdot v_r(x,t - m \cdot t_p), \quad (7)$$

$$t \leq (M + 1) \cdot t_p$$

### 3.3.3 Fourier solution

The basic ramp problem in (5) may be solved by a Fourier series expansion. A detailed report of this is given in (Claesson, 2006). The solution for  $t \geq 0$  is given by:

$$v_r(x, t) = t - \frac{LL_0 + D_m t_0 + xL - x^2/2}{D_m} + \sum_{n=0}^{\infty} B_n \cos[\alpha_n(1 - x/L)] \cdot e^{-\alpha_n^2 D_m t/L^2} \quad (8)$$

Here, the Fourier coefficients are

$$B_n = \frac{2L^4}{D_m \alpha_n^2} \cdot \frac{\cos(\alpha_n)}{L_0 L \alpha_n^2 + \cos^2(\alpha_n) \cdot (D_m t_1 \alpha_n^2 + L^2)} \quad (9)$$

The eigenvalues  $\alpha_n$  are the solution to

$$\frac{L}{L_0 \cdot \alpha_n} - \frac{D_m t_1}{L^2} \cdot \alpha_n = \tan(\alpha_n), \quad 0 < \alpha_0 < \alpha_1 < \dots \quad (10)$$

The series solution converges very rapidly except for small times. An alternative solution from Laplace transformation is then used. The complete solution is implemented in Mathcad. The result with five-digit accuracy is obtained requiring very little computer time (less than 2 s for the case of Fig.4). All these details are reported in (Claesson, 2006).

## 4 Results

### 4.1 Determination of material moisture properties

The sorption isotherms for the felted wool fabric and polyether foam shows a great difference in moisture capacity see Fig. 5. The diffusivity for the wool fabric in the range 35-75% RH was estimated to  $450 \cdot 10^{-6} \text{ m}^2/\text{s}$ .

The results of the water vapor resistance  $Z_m$  without corrections, and the resistance in the specimen material itself  $Z_p$  with corrections for  $Z_a$ ,  $Z_1$  and  $Z_2$  for the 31 mm polyether foam is shown in table 2. The material parameters used in the calculation of the analytical solution is shown in table 3.

## 4.2 Comparison between chair measurements and analytical solution

The analytical solution uses an ideal triangular variation for the ambient climate (e.g. boundary conditions) and is therefore not capable of taking the small fluctuations caused by the climatic system into account, see Fig. 6. Still the analytical solution provides a good representation of the moisture uptake in the chair seat. An addition of internal resistance in the analytical solution as well as using truer boundary conditions would improve the already satisfactory agreement between measurement and theoretical calculations even more.

## 5 Discussion

The results of the water vapor resistance  $Z_m$ -average without corrections for the 31 mm polyether foam are in range 0.34-0.35 GPa·s·m<sup>2</sup>/kg for the two intervals of RH, which gives the results of the water vapor resistance  $Z_p$ -average with corrections for  $Z_a$ ,  $Z_1$  and  $Z_2$  in the same range 0.27-0.28 GPa·s·m<sup>2</sup>/kg for the two intervals of RH. The corrections are in the range 0.07 GPa·s·m<sup>2</sup>/kg which is 20 % of  $Z_m$ .

In the measurements the air layer thickness inside the cup was 6 mm, while EN ISO 12572:2001 recommends 15 mm air layer thickness. Smaller air space between sorption material and specimen gives higher RH on specimen surface against cup for the interval 75-49% RH, as resistance of air layer is smaller. But also the overall measured diffusion resistance for the test  $Z_m$  for this very porous polyether foam is highly influenced by the air layer thickness. The large influence of the resistance in the air gap makes the traditional cup method unsuitable for thin and permeable textile layers. The method to evaluate the diffusivity from the step measurements made in the sorption balance is promising but need further validation. They also provide simultaneous determination of sorption isotherms and moisture transport properties.

The determination and estimation of surface and internal resistance to the type of multi-layered material combinations that this chair seat represent are also a matter for more investigations since they have a rather large impact on calculated results.

## 6 Conclusions

The presented analytical solution and measured data commence a better understanding of the moisture dynamics for furnishing such as textiles and soft furniture for daily variations in the indoor climate. More work is needed to find ways to couple this to room or building simulation tools. The methods to assess material properties used in this study showed to be useful for highly permeable materials.

## References

- Anderberg, A. (2004). Moisture properties of selflevelling flooring compounds.. Lund, Building Materials, ISSN 0348-7911 TVBM, Lund University.
- Claesson, J. and K. Svennberg (2006). Moisture dynamics of a textile sheet with an underlying polymer slab. Analytical solution for a piece-wise linear air humidity. Lund, Building Physics, TVBH-7231, Lund University.
- Crank, J. (1975). Mathematics of diffusion, Oxford Science Publisher.
- Hansen, K. K. and H. B. Lund (1990). Cup method for determination of water vapour transmission properties of building materials. Sources of uncertainty in the method. 2nd Symp. Building Physics in the Nordic Countries, Trondheim.
- Martin, P. C. and J. D. Verschoor (1986). Cyclical moisture desorption/absorption by building construction and furnishing materials. Symposium on Air, Infiltration, Ventilation and Moisture Transfer, Fort Worth, TX, USA, Building Thermal Co-ordinating Council.
- Mullit, P. (1993). KOPLYSE ver.3.0. Program til analyse af måleresultater opsamlet i KOP-udstyr., Lab. for Bygningsmaterialer, Teknisk Rapport 297/93, DTH.
- Plathner, P. and M. Woloszyn (2002). "Interzonal air and moisture transport i a test house. Experiment and modeling." Building and Environment 37: 189-199.
- Svennberg, K. (2003). Determination of Moisture Properties for Materials Exposed to the Indoor Air. Lund, Building Physics, TVBH-3042, ISBN 91-88722-27-9, Lund University.
- Svennberg, K. (2005). Sorption isotherms for textile fabrics and foam used in the indoor environment. Lund, Building Physics, TVBH-7227, Lund University.
- Svennberg, K., L. Hedegaard, & C. Rode (2004). Moisture Buffer Performance of a Fully Furnished Room. Whole Building Envelope IX. Clearwater Beach, FL, ASHRAE.

## **Acknowledgements**

The experimental help from Anders Anderberg and Dr. Lars Wadsö at Lund University and Lone Hedegaard and Dr. Carsten Rode at the Technical University of Denmark is gratefully acknowledged. The work was carried out with support from FORMAS and IKEA.

## Figures

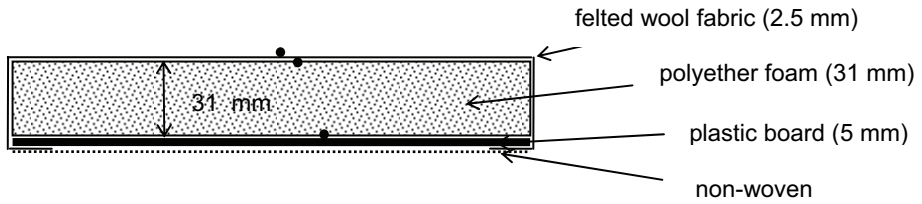


Figure 1: A schematic drawing showing the structure of the chair seat used for measurements and calculations. The placement of the temperature and RH-sensors is indicated with a (●).

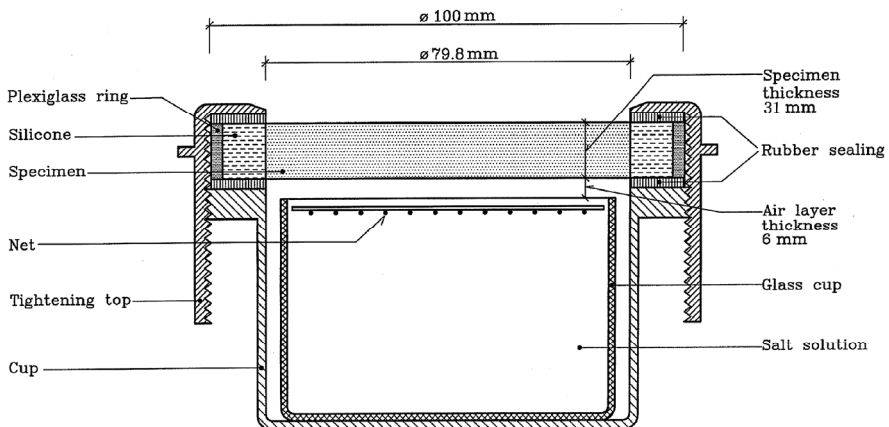


Figure 2: The experimental set-up in the cup method.



In this test, this wall was without a window.

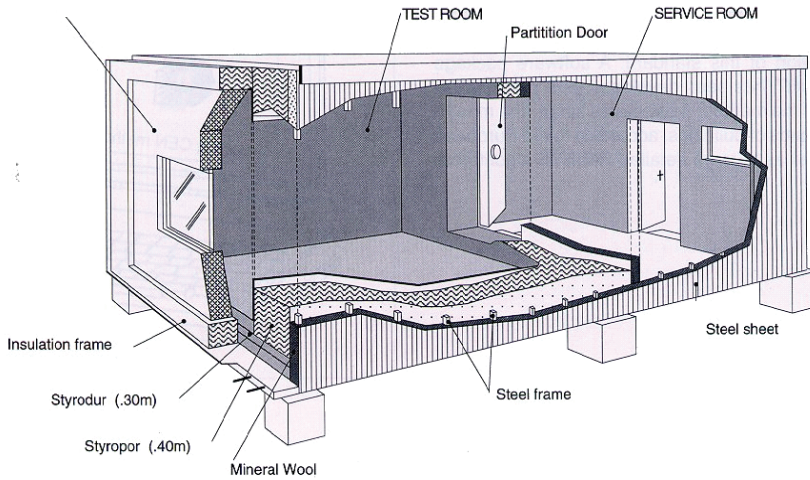


Figure 3 Drawing of the test cell. The test room is covered with steel sheets on the inside on all sides except the exchangeable facade, which is covered with a polyethylene foil to be moisture and air tight.

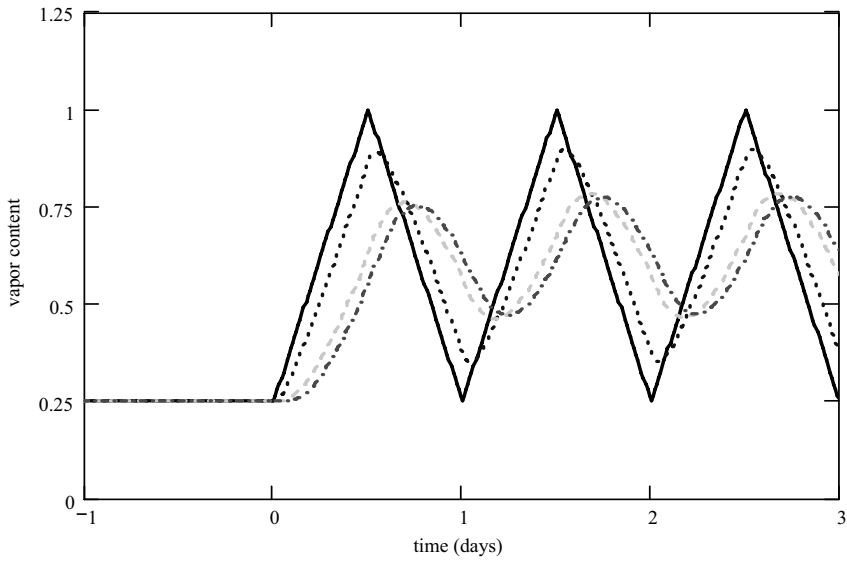


Figure 4: Water vapor content  $v_0(t)$  (solid black line) in the air at the boundary  $x = 0$ , normalized values of all parameters was used (all equal to 1). The dashed lines represent different depths in the foam: dotted black - under fabric, dashed grey - half depth in the foam, dash-dotted black - under the foam.

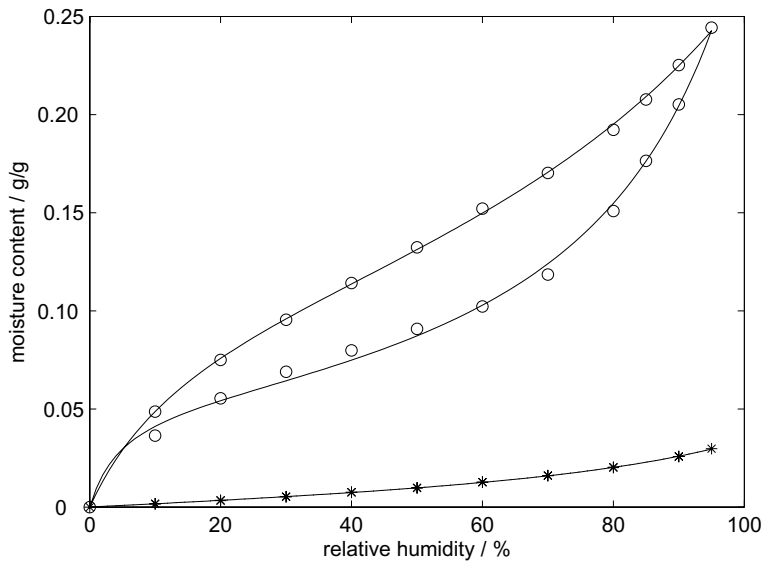


Figure 5: The sorption isotherm for the felted wool fabric (o) and the polyether foam (\*).

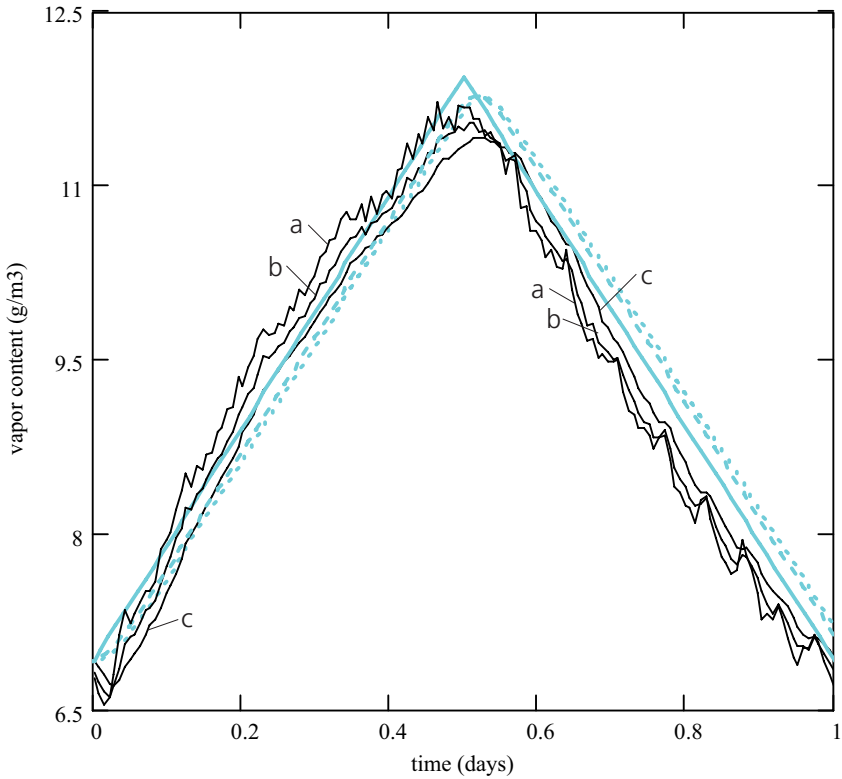


Figure 6: Comparison between the measured vapor content in the chair seat during the climatic chamber experiments (thin solid black lines: (a) the top surface, (b) under the fabric, (c) under the polyether foam) and the analytical solution (thick grey lines: solid – the top surface, dashed - under the fabric, dotted – under the polyether foam).

## Tables

**Table 1.** *Thickness and density*

<b>Material</b>	<b>Thickness</b> (mm)	<b>Density</b> (kg/m <sup>3</sup> )
Polyether foam	31	36
Felted wool fabric (100% wool)	2.5	176

**Table 2.** *The results of the water vapor resistance  $Z_m$  without corrections and the resistance in the specimen material itself  $Z_p$  with corrections for  $Z_a$ ,  $Z_1$  and  $Z_2$  for the 31 mm polyether foam. The RH inside the cups was 75% RH for cups no. 1-3 and 33% RH for cups no. 4-6.*

<b>Cup no.</b>	<b>Without corrections</b>		<b>With corrections</b>	
	<b><math>Z_m</math></b> (GPa·s·m <sup>2</sup> /kg)	<b><math>Z_m</math>-average</b> (GPa·s·m <sup>2</sup> /kg)	<b><math>Z_p</math></b> (GPa·s·m <sup>2</sup> /kg)	<b><math>Z_p</math>-average</b> (GPa·s·m <sup>2</sup> /kg)
1	0.34	0.34	0.27	0.27
2	0.33		0.26	
3	0.35		0.28	
4	0.35	0.35	0.28	
5	0.35		0.28	
6	0.36		0.29	

**Table 3.** *Material properties used in the theoretical calculations.*

<b>Material</b>	<b>Diffusivity</b> $D$ (m <sup>2</sup> /s)	<b>Moisture capacity</b> $\xi$ (-)	<b>Surface resistance</b> $Z_{sv}$ (s/m)	<b>Surface resistance</b> $Z_{sp}$ (GPa·s·m <sup>2</sup> /kg)
Felted wool fabric	$450 \cdot 10^{-6}$	0.44	100	0.014
Polyether foam	$0.36 \cdot 10^{-6}$	0.025	-	-

**Microclimates in Beds - Field Measurements and Simulation of Temperature and Moisture Conditions in Two Bed Systems.**

Svennberg, K., Claesson, J. and Wadsö, L.

Submitted to *Building and Environment*.



# Microclimates in Beds – Field Measurements and Simulation of Temperature and Moisture Conditions in Two Bed Systems

Kaisa Svennberg, Lic. Eng., M. Sc.<sup>1</sup>

Building Physics LTH, Lund University; Sweden

Johan Claesson, Ph D

Building Physics LTH, Lund University and Building Technology, Chalmers  
University of Technology; Sweden

Lars Wadsö, Ph.D.

Building Material LTH, Lund University; Sweden

**KEYWORDS:** measurements, simulations, temperature, relative humidity (RH), mattress, bedding, bed, house dust mites (HDM), climatic conditions, material properties.

## Abstract:

House dust mites are a common source of allergy in, e.g., Scandinavia, where their major habitat is in beds where they feed on skin scales. Previous studies show that in drier environments the house dust mite occurrence is lower, and persons with dust mite allergy have fewer symptoms during the winter when the indoor relative humidity (RH) is low. There have also been attempts to alter the microclimatic conditions in beds to reduce the house dust mite occurrence. The microclimatic conditions in beds have also been studied earlier both in field measurements and by modeling but there is still a lack of knowledge of how the hygrothermal material properties of the mattresses and bedding affect the environmental conditions for the house dust mites. This paper presents diurnal temperature and RH variations in two mattress and beddings under normal use measured for two different bed systems. The results from the field study have been compared with the results from a simulation model for the hygrothermal conditions in each bed. This study is a part of a multi-disciplinary project aimed at finding technical solutions for reduction of house dust mites in bedrooms by environmental control.

---

<sup>1</sup> Corresponding author: Kaisa Svennberg, Building Physics LTH, Lund University, Box 118, SE-221 00 Lund, Sweden. E-mail: [kaisa.svennberg@byggtek.lth.se](mailto:kaisa.svennberg@byggtek.lth.se)



# 1 Introduction

House dust mites (HDM), small (<0.5 mm) arachnid animals, are a common source of allergy in Scandinavia and have beds as one of their major habitats. The climatic conditions of beds are therefore important parameters when trying to find technical solutions for reduction of HDM in beds and bedrooms. A number of previous studies have shown that in drier environments the HDM occurrence is lower and persons with HDM allergy have fewer symptoms during the winter season when the indoor relative humidity (RH) usually is lower (Arlian, Bernstein et al. 1982; Schei, Hessen et al. 2002 Jun). However, a recent literature survey (Wadsö and Svennberg 2005) shows that the climatic conditions required to control the HDM activity are complex and do involve RH, temperature and exposure periods. It is therefore important to obtain information on the RH and temperature variations in beds, both from measurements of actual climatic conditions in beds during use and from calibrated calculation models.

The microclimatic conditions in beds have been studied earlier both in field measurements and by modeling. Cunningham developed small RH sensors and made measurements in one bed and used material characteristics obtained from this measurement in the model he proposed (Cunningham 1998; Cunningham 1999; Cunningham, Roos et al. 2004). Pretlove has developed a model for calculations of the average climatic conditions in the bed core, which is the space between the mattress and the duvet (not to be confused with the mattress). Pretlove and co-workers have also proposed a combined transient hygrothermal and population model for beds (Pretlove, Rideley et al. 2001; Pretlove, Oreszczyn et al. 2005). Hokoi and co-workers (2004) have studied the influence of heat and moisture transfer in beddings on comfort and physiological responses in humans. The thermal conditions in the upper part of the bedding, duvet, blanket etc., have been investigated by Wilson and co-workers (Wilson, Niven et al. 1999; Wilson, Laing et al. 2004). The impact of different bed systems on allergen prevalence has also been investigated by among others van den Bemt and co-workers (2006) and Schei (2002). Still there is a lack of knowledge concerning the microclimatic differences for varying bed systems and also a need for a deeper understanding of the impact material selection will have on the microclimatic conditions in the bed.

The objective of this study was two-fold: to increase the knowledge of the temperature and moisture conditions in beds during use and to propose a basic one-dimensional model that captures the essential hygrothermal characteristics

of the bed systems using ordinary hygrothermal material properties. This paper presents the diurnal temperature and RH variations in mattress and beddings under normal use measured for two different mattress types and a basic simulation of the hygrothermal conditions for each of the two bed systems using separately determined material properties.

## **2 Bed systems**

In this study two beds in two bedrooms in the same house, on the west coast of Sweden, were used for measurement of diurnal temperature and RH variations. The same bed systems with simplifications were also used for simulation of diurnal hygrothermal variations. The two bedrooms are placed on the second floor and have the same orientation. The basic furniture and the quantity of moisture buffering materials are the same in both rooms, only the bed type differs. (See the section "Mattress and bedding materials" below.) The area and volume of each room are 10 m<sup>2</sup> and 25 m<sup>3</sup>, respectively. The beds were occupied by two young persons – a male for bed A and a female for bed B. The persons are of the same body size and have approximately the same body mass. In this study there were no measurements made to take into account the differences in sleeping pattern and individual moisture and temperature production.

### **2.1 Mattress and bedding materials**

#### **Bed A – homogenous mattress**

The bed consists of a 120 mm regular polyether foam mattress with a 100% cotton cover placed in a bedstead with wooden laths (66 x 19 mm with 60 mm spacing) with no overlay mattress. There are plastic boxes in the space (270 mm high) underneath the bed. The duvet has a helically crimped polyester fiber batting with a polyester/cotton cover fabric. The pillow is filled with polyester hollow fiber balls and has a polyester/cotton cover fabric. The bottom sheet, duvet cover and pillowcase are made of 100% cotton plain weave fabric. The structure of bed A is shown in Fig. 1a and the material properties are given in Table I.

## **Bed B – multilayered mattress**

The bed consists of an interior sprung mattress (170 mm thick) with an overlay mattress (70 mm thick). The sprung mattress is supported by a bedstead with 70 x 19 mm wooden laths, 60 mm spacing. The overlay mattress has a 40 mm viscoelastic polyether foam core which is covered on both sides with 15 mm wool batting. The space (260 mm high) underneath the bed was empty. The duvet, pillow and bedding are identical to the one used in bed A. The structure of bed B is shown in Fig. 1b and the material properties are given in Table I.

### **Material properties**

The material properties for the bed systems were obtained from both direct measurements and tabulated values from literature. The sorption isotherms for all materials and the moisture diffusivity for cotton sheet was determined through measurements in a dynamic vapor sorption balance (DVS) and are described in detail by Svennberg & Wadsö (submitted). The evaluation of the moisture diffusivity is based on a method for simultaneous determination of sorption isotherms and moisture diffusivity by Anderberg & Wadsö (2004). The moisture diffusivity was thereafter recalculated to vapor permeability. The determination of the vapor permeability of bedding materials is a problematic area. If the various measurement methods for these lightweight and highly permeable materials are compared they show to give a large variation between them, even if the same material is tested (McCullough, Myongsook et al. 2003). We have made comparisons in our evaluation between the cotton sheet and other materials with similar properties such as paper and found the diffusivity to be reasonable. The vapor permeability of the foam was determined by an upright cup-method and the results are presented in detail by Svennberg and co-workers. (Svennberg, Claesson et al. 2005). The vapor permeability for the battings and the thermal properties for all materials were taken from literature (Kumaran 1996; Hansen de Place and Hansen Kielsgaard 1999). Since there is a general lack of appropriate and reliable material properties concerning bed materials, the material data collected from literature were for materials judged to be equivalent to the materials of the bed systems. If the compression would be taken into account that would provide another challenge in the determination of the material properties, and this challenge could be enlarged even more if a three dimensional deformation of the mattress were to be considered.

### **3 Field measurement**

The objective of the field measurement was to obtain hygrothermal climatic conditions in two types of bed systems – one homogenous mattress (Bed A) and one multilayered mattress (Bed B) and to test a new sensor set-up for bed measurements under normal use.

#### **3.1 Measuring equipment**

Two requirements for the measuring equipment were that it should not impose discomfort for the persons sleeping in the beds and it should be robust enough to stand friction from moving persons. It had also to be rather inexpensive as several measurement points are needed to map the microclimate in a bed. To meet these requirements a combined RH and temperature sensor connected to a logger device operated in a "stand-alone" mode was developed.

The combined sensor (Fig. 2) was made from a commercially available RH sensor and a thermistor. The RH sensor (Honeywell HI-3610), which was previously used by Baker and co-workers (2004) in study of microclimatic conditions in upholstered furniture, is a commercially available polymer capacitive sensor with on-chip integrated signal conditioning. The uncalibrated sensor has an accuracy of  $\pm 5\%$  RH for the complete non-condensing interval and a maximum hysteresis of  $\pm 1.2\%$  RH. The time constant in slowly moving air is 15 s. The thermistor was a commercial precision resistance-temperature matched thermistor with a temperature measurement accuracy of  $\pm 0.2\text{K}$  for a 0 to  $70^\circ\text{C}$  temperature range. The time constant for the thermistor is 10 s in air. The thermistor was placed on the plastic holder of the RH sensor and both sensors were covered in a rigid shrink tube. A small slit was made in the tube at the RH-sensor element.

#### **3.2 Measurement set-up**

In each measurement series eight combined RH and temperature sensors were used. Two sensors were used to monitor the room climate; one sensor was hung in a thin steel wire in the center of the room approximately 2 m above the floor (RC), one sensor was placed underneath the lath support in the bed (RUB). The other six sensors were arranged in three groups of two each in the bed: head region (HR), torso region (TR) and leg region (LR) as shown in Fig. 3. The sensor on top of the mattress in each region was labeled #1 and the sensor under the mattress #2. The sensors were fastened into position in the bed systems using duct tape. In the evaluation it was found that the RH sensor

in one of the sensors in the head region (HR1) had a permanent failure. Because of this and the large fluctuations due to movement of the sleeper in the leg region, only the room climate and the measurements from the torso region have been used in the present study. The evaluation of all three bed regions is reported in (Wadsö and Svennberg 2005). The temperature and RH were monitored every 5 minutes for 4 days for each bed system. Time zero was set at the start of the first sleeping period in the study, approximately at 21.00, and each sleeping period lasted for 8 – 10 hours.

## 4 Mathematical model

The transient temperature and vapor content response is calculated using a basic mathematical simulation model made up of two one-dimensional networks representing two systems of coupled ordinary differential equations (ODE) – one for the thermal calculations and one for the hygric calculations. Constant material properties are used and the temperature dependency for the moisture parameters is neglected. This means that the two systems are uncoupled from each other. The mattress geometry was simplified by disregarding all casing materials and the compression of the mattress materials during use.

### 4.1 General case

Figure 4 shows a thermal network with  $N$  nodes. Node  $n$  has the heat capacity  $C_n$  (J/K). In the calculations, a unit area ( $1 \text{ m}^2$ ) is considered in the horizontal plane perpendicular to the vertical heat and moisture flow processes. The thermal conductance between nodes  $n$  and  $n+1$  is  $K_n$  (W/K). The heat balance equations for the  $N$  nodes are

$$C_n \cdot \frac{dT_n}{dt} = K_{n-1} \cdot [T_{n-1}(t) - T_n(t)] + K_n \cdot [T_{n+1}(t) - T_n(t)], \quad n = 1, 2, \dots, N \quad (1)$$

The initial values  $T_n(0)$ ,  $n = 1, 2, \dots, N$ , are prescribed. The boundary temperature at the top of the mattress  $T_0(t)$  is a prescribed function of time  $t$  and  $T_{N+1}$  is the constant boundary temperature at the bottom of the mattress.

The equations may be written in matrix form:

$$\mathbf{C} \cdot \frac{d}{dt}(\mathbf{T}) = \mathbf{K} \cdot \mathbf{T} + \mathbf{B}(t) \quad (2)$$

Here,  $\mathbf{T}$  is a column vector with the  $N$  components  $T_n(t)$  ( $n = 1, \dots, N$ ). The  $N \cdot N$  matrix  $\mathbf{C}$  has the heat capacities  $C_n$  in the diagonal, while all non-diagonal elements are zero. The conductance matrix has the values  $-K_n - K_{n-1}$  ( $n = 1, \dots, N$ ) in the diagonal, and  $K_1, \dots, K_{N-1}$  in the bidiagonals. The column vector  $\mathbf{B}(t)$  that accounts for the boundary conditions has the components  $B_1(t) = K_0 \cdot T_0(t)$  and  $B_N = K_N \cdot T_{N+1}$ , while the remaining ones are zero.

The solution is obtained with the standard method involving eigenvalues and eigenvectors to the matrix  $\mathbf{C}^{-1} \cdot \mathbf{K}$ . The eigenvalues are obtained from the equation

$$\det(\lambda \mathbf{I} + \mathbf{C}^{-1} \mathbf{K}) = 0 \quad \rightarrow \quad \lambda = \lambda_1, \dots, \lambda_N \quad (3)$$

Here,  $\mathbf{I}$  is the unit matrix. Let  $\mathbf{U}$  be the matrix with the eigenvectors,  $\mathbf{U}^{(n)}$ , as columns:

$$\mathbf{C}^{-1} \mathbf{K} \cdot \mathbf{U}^{(n)} = \lambda_n \cdot \mathbf{U}^{(n)}, \quad n = 1, 2, \dots, N \quad (4)$$

The solution in matrix form is now

$$\mathbf{T}(t) = \mathbf{U} \mathbf{E}(t) \mathbf{U}^{-1} \mathbf{T}(0) + \int_0^t \mathbf{U} \mathbf{E}(t-t') \mathbf{U}^{-1} \mathbf{C}^{-1} \mathbf{B}(t') dt' \quad (5)$$

Here,  $\mathbf{U}^{-1}$  is the inverse matrix to the eigenvector matrix  $\mathbf{U}$ . The matrix  $\mathbf{E}(t)$  has the exponentials  $\exp(-\lambda_n \cdot t)$  in the diagonal, while all non-diagonal elements are zero. The first term involves multiplication of matrices and the exponentials in time. The second part involves multiplication of matrices and an integration over  $0 \leq t' \leq t$  of the exponentials  $\exp(-\lambda_n \cdot (t-t'))$  multiplied by the boundary temperatures  $T_0(t')$  and  $T_{N+1}$ . This solution in matrix form is readily calculated with a mathematical program such as Mathcad.

The moisture balance equations for calculation of the vapor content  $v$  in the general case can be derived by analogy from the heat balance equation (Eq. 1) above. The temperature  $T$  will then be substituted with the vapor content  $v$  and the thermal conductance  $K_n$  and heat capacity  $C_n$  with the corresponding hygric conductance  $K_{v,n}$  and hygric capacity  $C_{v,n}$  giving the following equations:

$$C_{v,n} \cdot \frac{dv_n}{dt} = K_{v,n-1} \cdot [v_{n-1}(t) - v_n(t)] + K_{v,n} \cdot [v_{n+1}(t) - v_n(t)], \quad (6)$$

$$n = 1, \dots, N$$

The boundary vapor content  $v_0(t)$  at the top of the mattress is a prescribed function of time  $t$  and  $v_{N+1}$  is a constant boundary vapor content at the bottom of the mattress. The hygric network is shown in Fig. 5.

## 4.2 Homogenous mattress (bed A)

The homogenous mattress in Bed A is divided into six nodes in the thermal case. The thermal conductances and heat capacities are calculated as

$$K_0 = \frac{1}{L_s / \lambda_s + L_f / (2\lambda_f)} \quad (7)$$

$$K_n = \frac{\lambda_f}{L_f}; \quad n = 1, 2, 3, 4, 5 \quad (8)$$

$$K_6 = \frac{1}{L_f / (2\lambda_f) + 1/\alpha} \quad (9)$$

$$C_n = L_f \cdot \rho_f c_f, \quad n = 1, 2, 3, 4, 5, 6 \quad (10)$$

Here,  $\lambda_s$  and  $\lambda_f$  are the heat conductivity of the cotton sheet and the polyether foam, respectively, and  $L_s = 0.25$  mm is the thickness of the cotton sheet,  $L_f = 20$  mm corresponds to 1/6 of the mattress thickness,  $\rho_f$  is the density of the polyether foam, and  $c_f$  is the heat capacity of the polyether foam. The constant  $\alpha$  is the surface heat transfer coefficient at the bottom surface of the mattress system. The denominator of (7) is the sum of the thermal resistance of the cotton sheet and half the thickness of the first layer of the polyether foam.

For the hygric case the bed system is divided into seven nodes, one node for the cotton sheet and six nodes for the polyether foam. The hygric conductances and capacities are calculated as:

$$K_{v,0} = \frac{\delta_{vs}}{L_s / 2} \quad (11)$$

$$K_{v,1} = \frac{1}{1/K_{v,0} + L_f / (2 \cdot \delta_{vf})} \quad (12)$$

$$K_{v,n} = \frac{\delta_{vf}}{L_f}, \quad n = 2, 3, 4, 5, 6 \quad (13)$$

$$K_{v,7} = \frac{1}{L_f / (2 \cdot \delta_{vf}) + 1 / \beta_{v,air}} \quad (14)$$

$$C_{v,1} = \frac{L_s}{v_{sat}} \cdot \left. \frac{dw}{d\phi} \right|_s \quad (15)$$

$$C_{v,n} = \frac{L_f}{v_{sat}} \cdot \left. \frac{dw}{d\phi} \right|_f, \quad n = 2, 3, 4, 5, 6, 7 \quad (16)$$

Here,  $\delta_{vs}$  and  $\delta_{vf}$  are the vapor permeabilities for the cotton sheet and the polyether foam respectively, and  $\left. \frac{dw}{d\phi} \right|_s$  and  $\left. \frac{dw}{d\phi} \right|_f$  are the slopes of the sorption isotherm, sometimes also referred to as the moisture capacities, for the cotton sheet and the polyether foam, while  $\beta_{v,air}$  is the moisture transfer coefficient (for difference in vapor content) at the bottom surface of the bed.

The properties of the materials used are found in Table I and the thermal and hygric conductances and capacities are given in Table II and III.

### 4.3 Multilayered mattress (bed B)

The thermal and hygric conductances and capacities for Bed B are calculated in the same way as for Bed A above, except that the spring mattress is approximated with an air gap with convection as well as radiation. The heat



capacity of node 6 is equal to the capacity of the air volume in the spring mattress. This gives a modification of the thermal network shown in Fig. 6a. There are two surface temperatures (between  $K_c$  and  $K'_5$ , and between  $K_c$  and  $K'_6$ ) to determine. This part of the thermal network is then not of the linear type for which equations (1) – (5) are directly applicable. But the network in Fig. 6a may be transformed into the network in Fig. 6b. The thermal conductances  $K_5$ ,  $K_6$  and  $K_{57}$  in Fig. 6b are determined from the conductances  $K'_5$ ,  $K_c$ ,  $K_r$  and  $K'_6$  by the following relations:

$$\begin{aligned}
 A &= 2K_r K_c + K_c^2, & K_a &= \frac{A}{K_r}, & K_b &= \frac{A}{K_c}, & K'_b &= \frac{K_b \cdot K'_5}{K_b + K'_5}, & K''_b &= \frac{K_b \cdot K'_6}{K_b + K'_6} \\
 A &= K_a + K'_b + K''_b, & K_5 &= \frac{K_a \cdot K'_b}{A}, & K_6 &= \frac{K_a \cdot K''_b}{A}, & K_{57} &= \frac{K'_b \cdot K''_b}{A}
 \end{aligned} \tag{17}$$

These relations are obtained from the  $\Delta$ -network involving  $K_c$ ,  $K_r$  and  $K_c$  by transforming it to a Y-network giving  $K_b$ ,  $K_a$  and  $K_b$ . The resistance  $1/K_b$  is added to  $1/K'_5$  and to  $1/K'_6$ , giving  $K'_b$  and  $K''_b$ . The Y-network between the nodes 5, 6 and 7 is then transformed to a new  $\Delta$  network with the conductances  $K_5$ ,  $K_6$  and  $K_{57}$  as shown in Fig. 6b. The Y- $\Delta$  transformations are described in (Hagentoft 2001).

The solution, (1)-(5) may now be applied with only the minor change in node 5 that has a connection to the bottom boundary temperature  $T_7$  via  $K_{57}$ . This means that the component  $B_5(t)$  is changed from zero to  $K_{57} \cdot T_7$ .

The various conductances and capacities are determined in analogy with the homogenous mattress and are given in Table IV. The hygric conductances and capacities are given in Table V.

#### 4.4 Boundary conditions used in calculations

In the thermal calculations the measured mean temperature under each bed (RUB) is used as constant boundary condition at the bottom of the thermal network (Fig. 4). The boundary condition in the top of the thermal network (TR1) is set to the mean room temperature during daytime and 35.5 °C for the sleeping period of each diurnal cycle. The temperature during sleeping period is slightly higher than literature value of 35 °C (Hokoi, Komoto et al. 2004),

but the sleepers are pre-adolescents and the temperature correlates well with our measurements.

In the hygric calculations the measured mean vapor content under each bed (RUB) is used as the boundary condition at the bottom of the hygric network. The boundary condition at the top of the hygric network (TR1) is set to the mean vapor content during daytime. During the sleeping period the surplus vapor content is guesstimated to be  $14 \text{ g/m}^3$  which are added to the daytime vapor content. The surplus vapor content is derived from the estimation of  $20 \text{ g/h}$  of insensible moisture production and that half of the moisture production affects the mattress. The assumptions above are of course quite rough and will be a source of error in the calculations.

## **5 Results and discussion**

### **5.1 Ambient conditions**

The climatic conditions (RH and temperature) of the rooms have similar diurnal variations. Bed B shows a good agreement between the climate under the bed (RUB) and in the room center (RC). Bed A shows a higher RH and a lower temperature under the bed (RUB) compared to the room center (RC), see Fig. 7.

### **5.2 Temperatures in beds**

The temperatures for top of the bed (TR1) are essentially the same for bed A and bed B and show good agreement with previous field measurements (Cunningham 1998) see Fig. 8.

The temperatures under the mattress (TR2) are lower for bed A compared with bed B, see Fig. 8. This was expected as the thickness of the mattress in bed B is only 58% of the mattress thickness in Bed A, and the spring mattress in Bed A provides more thermal insulation. Note that "under the mattress" (TR2) is not the same measuring point as "Under bed" (RUB).

In Fig. 9 the insulation effect of the underlying spring mattress in bed B is shown. This can be seen in the negative temperature differences at the end of each sleeping period, due to the slower cooling under the mattress in bed B. This pattern is not seen for the mattress in bed A which is exposed more directly to the room temperature on the bottom side of the mattress. The effect of making the bed and putting the bed cover on is also seen in Fig. 8. The

morning after the second sleeping period bed B was not made, it then follows a similar cooling pattern as Bed A that was never made during the measuring period. The temperature on the surface of the bed during occupancy is approximately 35.5 °C and correlates with the human skin temperature.

### **5.3 Relative humidity in beds**

The results from the RH measurements (Fig. 10) are hard to interpret, mainly because of the large fluctuations. These fluctuations are most probably due to the movement of the sleeping persons, giving a strong fluctuation in both temperature and moisture production in each measurement point. The movement by the sleeping person will also affect the ventilation of the space created between the mattress and the duvet, and therefore increase the fluctuations in the measurements. Both beds show RH lower than expected; this is most evident for Bed B that barely reaches 58% RH, believed to be the lowest critical RH for HDM growth (Arlan, Bernstein et al. 1982). In bed B the RH variations follow the same pattern as the temperature variations. The RH variations for bed A show an RH distribution that does not follow the sleeping periods as closely as bed B. These differences can be of importance when choosing the most favorable bed-system for HDM allergic persons. HDM will be more viable the longer the threshold RH level of 58%, usually referred to as the Critical Equilibrium Humidity (CEH) is exceeded (Arlan, Neal et al. 1999 a; Arlan, Neal et al. 1999 b). The diurnal RH variations emphasize the large effect temperature variations have on the microclimate of a bed (Fig. 10).

### **5.4 Vapor content in beds**

The vapor content variations during the sleeping periods at the top of the mattress are similar for both beds (Fig. 11). As expected the bottom of the mattress in bed A shows less variations and follows the vapor content variations of the room. As for the RH, the vapor content results for bed A suggest moisture redistribution during day-time that is not found for bed B where the vapor content for both top (TR1) and bottom (TR2) of the mattress is approaching the room vapor conditions during day-time. Also for the vapor content the impact of not making the bed is seen for bed B at the end of sleeping period 2. The bed then approaches the room vapor conditions more quickly when left unmade and without bed cover, see Fig. 11.

## 5.5 Comparison between calculations and measurements

Comparisons are made between calculations and measurements for the most typical sleeping period; for bed A night #3 and for bed B night #2. The time is normalized to be 24 hours when the sleeping period starts. After the sleeping period none of the beds was made and in the calculation model the "upper" bedding made up of duvet, pillow and bedcover is disregarded. This limitation together with the simplifications already stated in section 4 makes the calculation model only useful as a comparative tool.

Figures 12 a and b show calculated and measured temperatures for beds A and B. For bed B the deviation in time scale for the cooling when the bed is unoccupied, is more accentuated than for bed A. The longer time scale seen in the measurements is most likely due to extra thermal capacity represented by the bedding disregarded in the model and to imprecise material properties.

The fluctuations seen in the measurement for both bed A and B are due to the movement of the person. The best solution will probably be to measure the temperature in several points throughout each level of the bed. However, this might affect the comfort of the user and secondarily have an impact on the sleeping pattern. Therefore, great care should be taken to avoid discomfort when such a measurement is performed.

In Figs. 13 a and b the comparison between calculated vapor content and measured is shown. Also here the homogenous bed A shows better agreement than bed B. The calculations underestimate the vapor content under the mattress (TR2) and under the bed for bed A (RUB); this might be a result of the plastic boxes stored in the space under bed A. However, the calculation overestimates the vapor content in the same positions in bed B (TR2 and RUB). This may be due to simplifications made for the multilayered bed where the casing materials for the spring mattress and the overlay mattress are omitted and perfect contact between the layers are assumed. The time scales for the calculation for bed B are longer than for the measured. The timescales for both bed systems are considerably longer than the thermal cases and do not reach quasi-equilibrium condition until approximately half way into the sleeping period.

The basic simulation model gave a reasonable agreement with measurements that may be improved if the temperature and vapor content were to be calculated in a coupled system of equations. This could be done using general numerical ODE solvers, but this calls for more refined material properties that take into account both the temperature and moisture dependency, and possibly

the effect of compression. The model would also be improved if the boundary condition in the hygric calculations were described as a vapor flux rather than a vapor content, this modification could be done within the framework of the solution of equation (1)-(5).

It is difficult to find material properties for the lightweight and compressible materials used in beds in literature, and such values are also difficult to determine. More research regarding the hygrothermal material properties could provide a platform for a better understanding of the microclimatic variations in beds during use. Further investigations regarding the importance of sleeping pattern and individual moisture production need to be made.

## 5.6 Measurement equipment

The measurement equipment proved to work, causing very little discomfort for the sleepers. One of them said that the sensors on top of the mattress could be noticed when going to sleep – “like a crease on the sheet”, but both sleepers agreed that they were not disturbed. The sensors also proved to be robust – one RH sensor (HR 1) had a permanent failure already after 15 min of use, most likely due to poor soldering. The fastening by duct tape was easy to apply and did keep the sensors in place for the whole measurement period. An even better solution would of course be to place sensors inside the bed system, but this is not a non-destructive method so it would be more difficult to get permission to perform such measurements. Since the fluctuations in the measurements probably are to a large extent due to the movement of the sleeper, a grid of measuring points over the area of the bed would improve the reliability of the measurements.

## 6 Conclusions

The results from the measurements show that bed systems with different material combinations have noticeable differences in microclimatic conditions during use. The temperature during the sleeping period increased significantly under the sleeping person while the RH had a more modest increase. There were considerable differences in the RH variations during daytime (no occupancy) between the two beds. This could be of importance to consider when trying to control or eradicate the HDM in the bed.

Even though the calculations and measurements give reasonable agreement, the proposed model should to be seen as a first attempt to use actual material properties as input data.

The combined temperature- and RH-sensor together with the logger showed to be working well and did not give the sleeping persons any discomfort.

## Acknowledgements

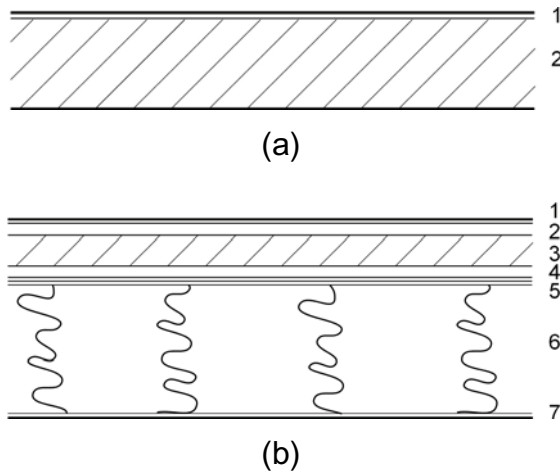
The development of the measurement equipment by Thord Lundgren at Lund University is gratefully acknowledged. We are also grateful for the participation of the two young sleepers. This study was funded by FORMAS and SBUF.

## References

- Anderberg, A. Moisture properties of selflevelling flooring compounds, Lund, Building Material, Lund University
- Arlian, L., I. Bernstein, et al. (1982). "The prevalence of house dust mites, *Dermatophagoides* spp, and associated environmental conditions in homes in Ohio." J Allergy Clin Immunol **69**(6): 527 - 32.
- Arlian, L., J. Neal, et al. (1999 a). "Fluctuating hydrating and dehydrating relative humidities effects on the life cycle of *Dermatophagoides farinae* (Acari: Pyroglyphidae)." J Med Entomol **36**(4): 457 - 61.
- Arlian, L., J. Neal, et al. (1999 b). "Reducing relative humidity to control the house dust mite *Dermatophagoides farinae*." J Allergy Clin Immunol **104**(4 Pt 1): 852 - 6.
- Baker, P., C. Hunter, et al. (2004). Measurement and Prediction of Indoor Microenvironments for the Control of Biocontaminants. CIB W 40. C. Sanders. Glasgow, CIB / RICH. **3**.
- Cunningham, M. (1998). "Direct measurements of temperature and humidity in dust mite microhabitats." Clin Exp Allergy **28**(9): 1104 - 12.
- Cunningham, M. J. (1999). "Modelling of some dwelling internal microclimates." Building and Environment **34**(5): 523-536.
- Cunningham, M. J., C. Roos, et al. (2004). "Predicting psychrometric conditions in biocontaminant microenvironments with a microclimate heat and moisture transfer model - description and field comparison." Indoor Air **14**(4): 235-242.
- Hagentoft, C.-E. (2001). Introduction to Building Physics. ISBN 91-44-01896-7, Göteborg, Studentlitteratur.
- Hansen de Place, E. J. and K. Hansen Kielsgaard (1999). Vanddamppermeabilitet (kopforsøg) Del af Varme- og fugttekniske undersøgelser af alternative isoleringsmaterialer. Series R. Kgs. Lyngby, Dep of Structural Engineering and Materials Technical University of Denmark.

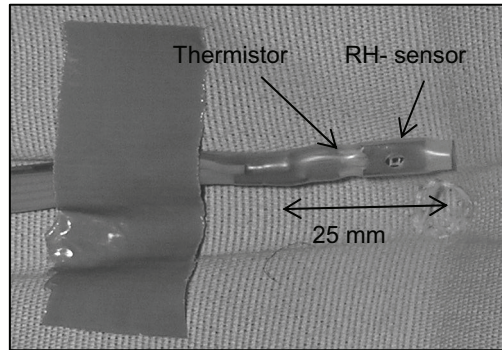
- Hokoi, S., N. Komoto, et al. (2004). Environmental control for comfortable sleeping, considering both physiological responses of human body and influence of heat and moisture in bedding. CIB W-40. Glasgow.
- Kumaran, K. M. (1996). Final Report. Vol 3 Task 3: Material properties. Heat, Air and Moisture Transfer in Insulated Envelope Parts. Leuven, KU-Leuven, Belgium: 135.
- McCullough, E. A., K. Myongsook, et al. (2003). "A comparison of standard methods for measuring water vapour permeability of fabrics." Meas. Sci. Technol. **14**: 1-7.
- Pretlove, S., I. Rideley, et al. (2001). A combined transient hygrothermal and population model of House Dust Mites in beds. IAQ 2001. San Francisco, ASHRAE.
- Pretlove, S. E. C., T. Oreszczyn, et al. (2005). "A steady-state model for predicting hygrothermal conditions in beds in relation to house dust mite requirements." Building Services Engineering Research and Technology **26**(4): 301-314.
- Schei, M., J. Hessen, et al. (2002 Jun). "House-dust mites and mattresses." Allergy **57**(6): 538 - 42.
- Svennberg, K., J. Claesson, et al. (2005). Moisture penetration in a chair seat as a response to daily RH variations in the indoor air Climatic chamber measurements and calculations. Nordic Building Physics Symposium. Reykjavik.
- Svennberg, K. and L. Wadsö (submitted). "Sorption isotherms for textile fabrics, foams and batting used in the indoor environment." J Textile Inst
- van den Bemt, L., M. P. de Vries, et al. (2006). "Influence of mattress characteristics on house dust mite allergen concentration." Clinical and Experimental Allergy **36**: 233-237.
- Wadsö, L. and K. Svennberg (2005). Bedrooms without house dust mites. Final report from a preliminary study. Lund, Building Materials and Building Physics, TVBM -7181, TVBH-7230.
- Wilson, C. A., R. M. Laing, et al. (2004). "Intrinsic "dry" thermal resistance of dry infant bedding during use. Part 2: estimated vs measured." Int Jo Cloth Sc and Techn **16**(3): 310-323.
- Wilson, C. A., B. E. Niven, et al. (1999). "Estimating thermal resistance of the bedding assembly from thickness of materials." Int Jo Cloth Sc and Techn **11**(5): 262-276.

## FIGURES

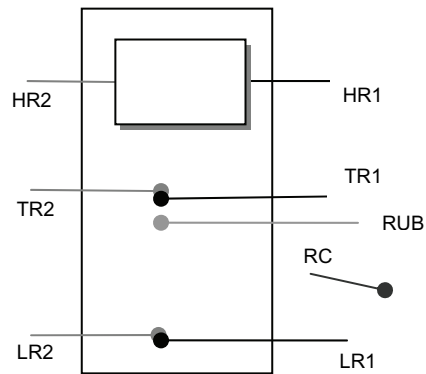


**Figure 1.** (a) The structure of bed A. Cotton sheet (1) and the homogeneous regular polyether foam mattress (2).  
(b) The structure of bed B. Cotton sheet (1), a wool batting (2) and (4), a viscoelastic polyether foam (3), a polyester batting (5) and (7) and metal springs in an air gap (6).

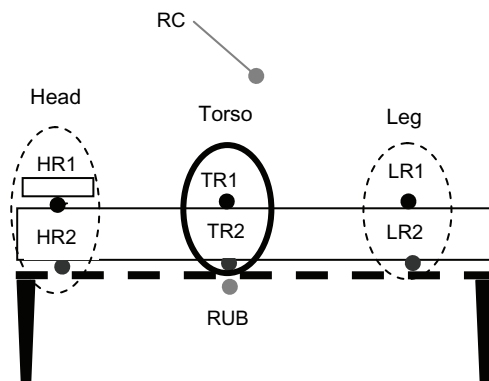




**Figure 2.** The combined temperature and RH sensor mounted on the mattress with duct tape. Note the small slit in the shrink tube at location of the RH sensor.

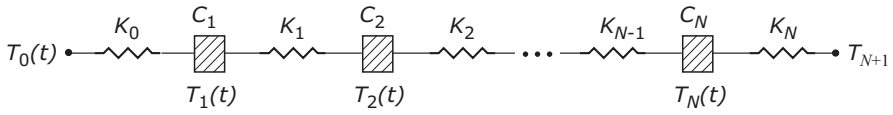


(a)

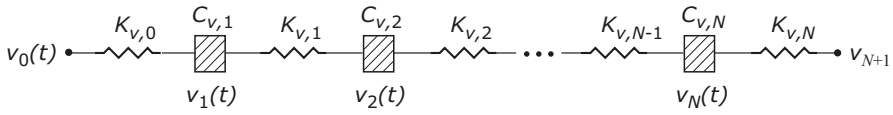


(b)

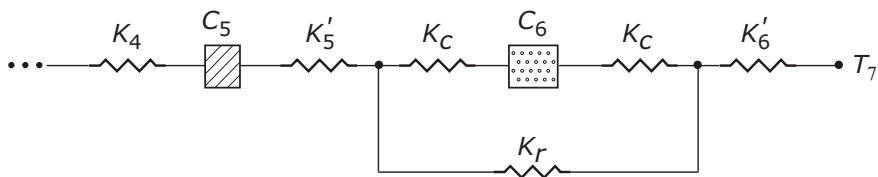
**Figure 3.** The placement of the sensors is shown from above (a) and from the side (b). Note that for bed B the mattress studied is on top of an interior spring mattress and sensors HR2, TR2 and LR2 are not in contact with the wooden laths. In this paper the analysis is limited to the room climate (RC & RUB) and the torso-region (TR1 & TR2).



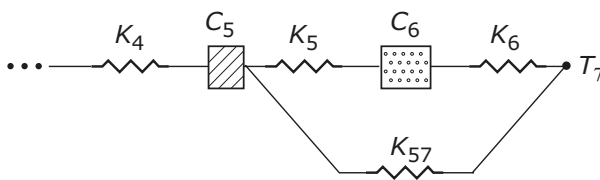
**Figure 4.** The thermal network for the general case having N nodes.



**Figure 5.** The hygic network for the general case having N nodes.

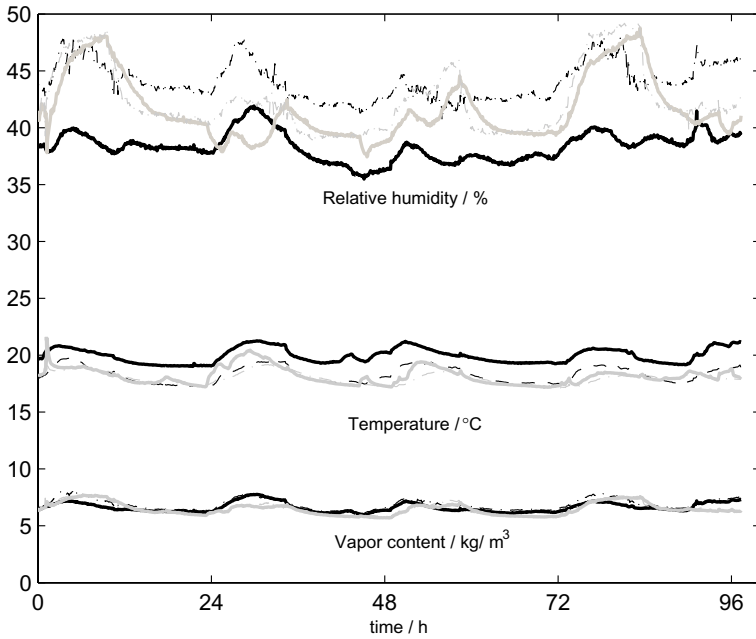


(a)

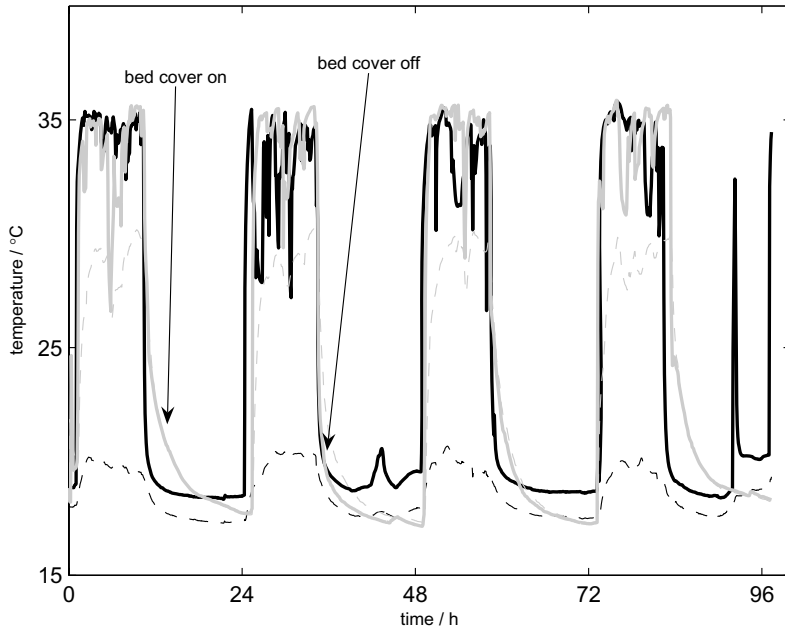


(b)

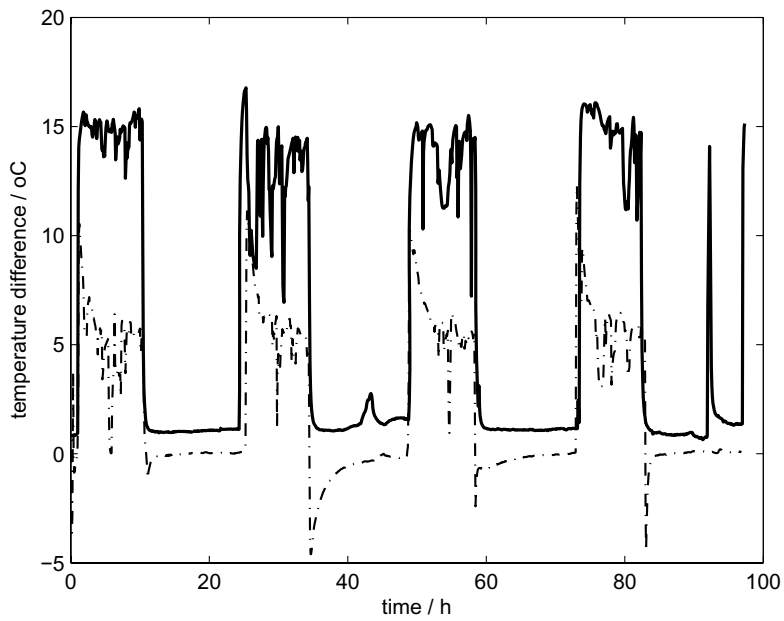
**Figure 6.** (a) The thermal network for the spring mattress (bed B) including radiation and convection.  
 (b) Alternative form of the thermal network (a) using Y- $\Delta$ -transformations.



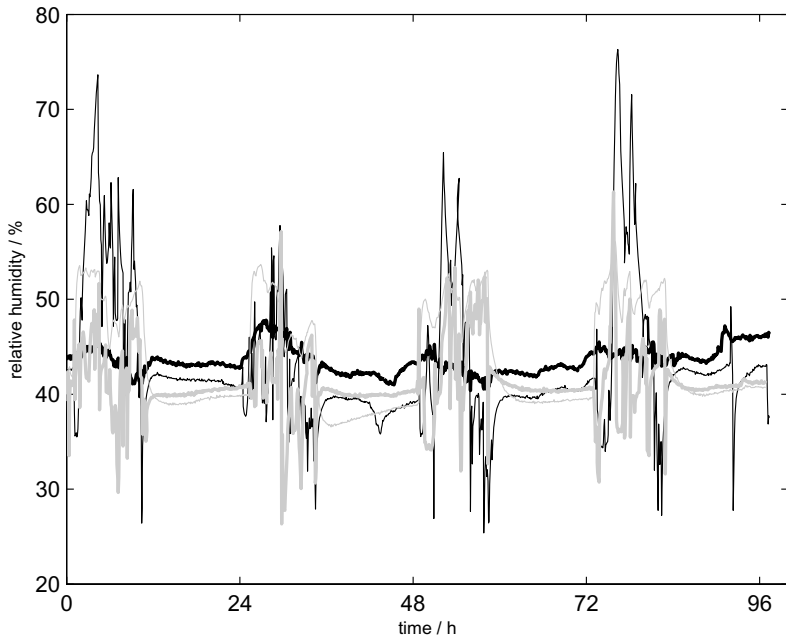
**Figure 7.** The indoor climate for room A (black lines) and B (grey lines) during the measurement period. Thick lines refer to the room center (RC) and thin dashed lines refer to under the bed (RUB).



**Figure 8.** Temperature comparison between bed A (black lines ) and bed B (grey lines) – for the torso region showing among other things the thermal effect of having the bed covers on or not. The top of the mattress (TR1) is the solid line and the bottom of the mattress (TR2) the dashed line for each bed respectively.

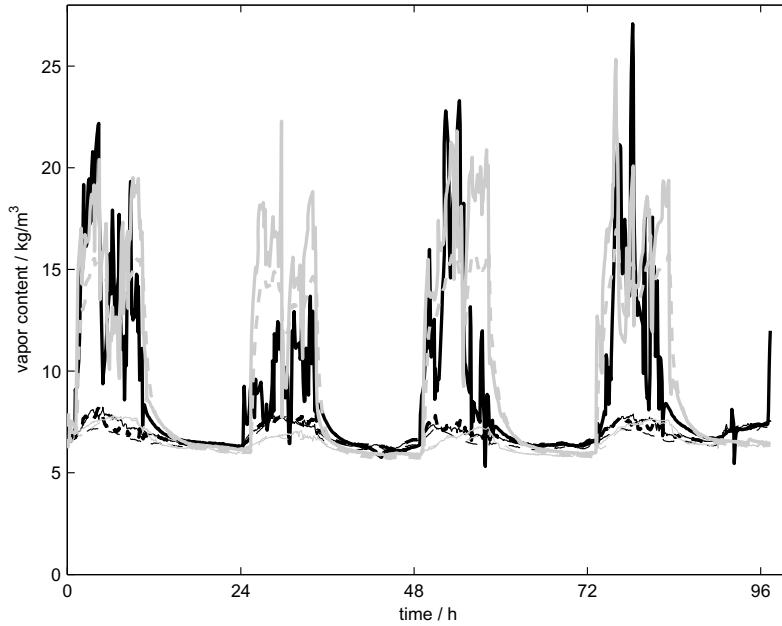


**Figure 9.** Temperature differences top (TR1)-under mattress (TR2) for bed A (solid line) and B (dash-dotted line).

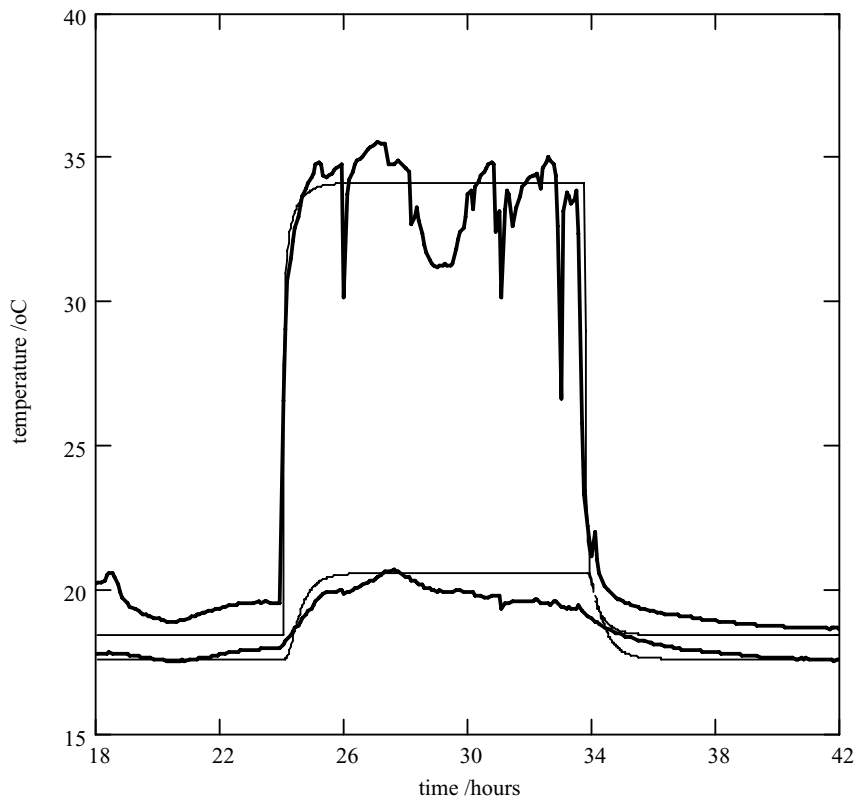


**Figure 10.** The variation in RH for bed A (black lines) and B (grey lines). The top of the mattress (TR1) is the thick line and the bottom of the mattress (TR2) the thin line for each bed respectively.

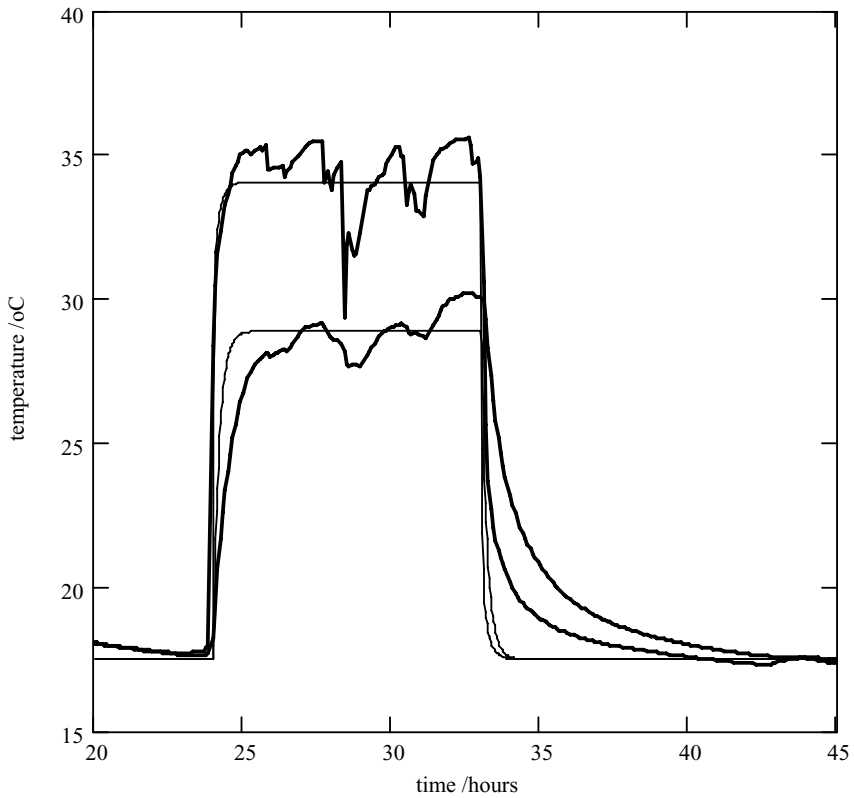




**Figure 11.** The variation in vapor content for bed A (black lines) and B (grey lines). The top of the mattress (TR1) is the thick line and the bottom of the mattress (TR2) the thin line for each bed respectively.

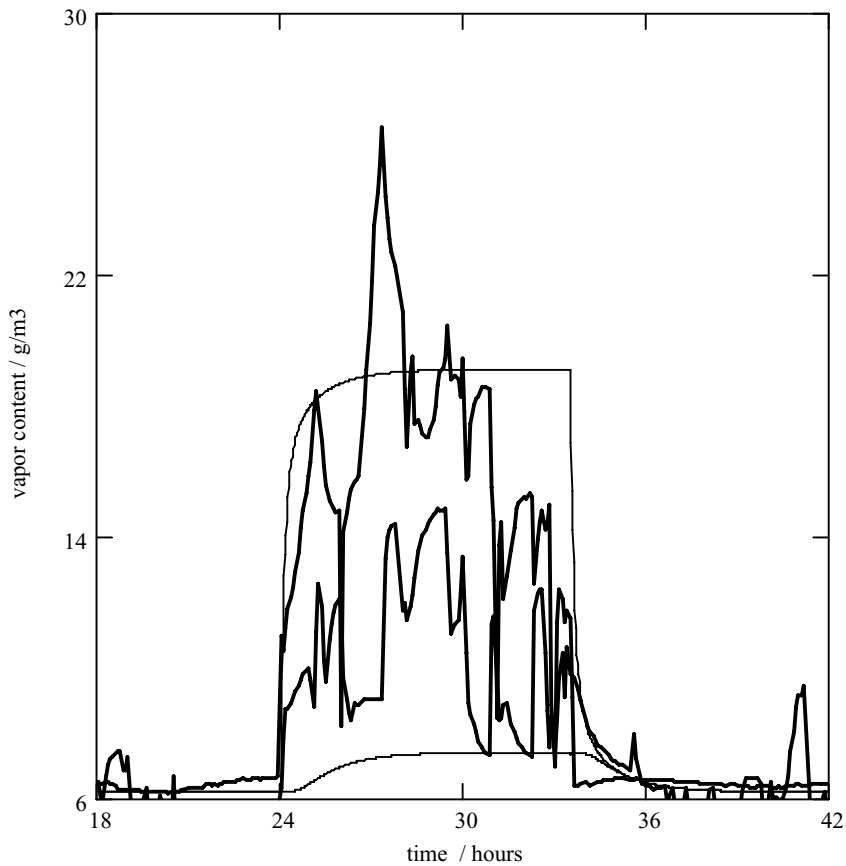


(a)

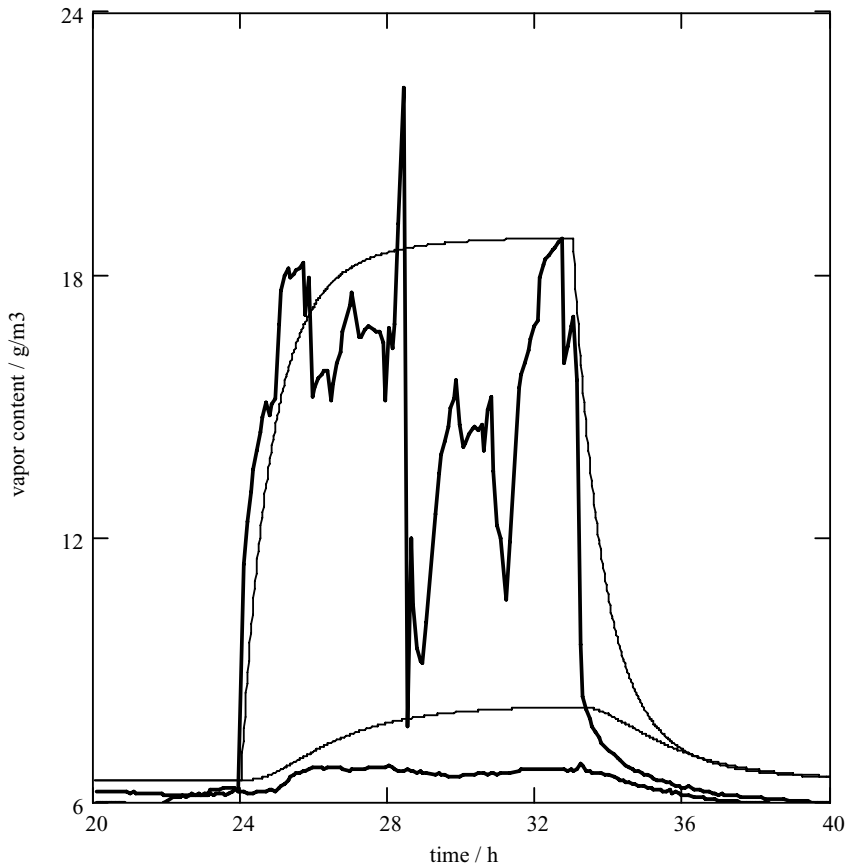


(b)

**Figure 12.** Thermal conditions for bed A (a) and B (b) measured and simulated for both bed systems. One sleeping cycle of 24 hours is shown. Measured temperatures are drawn with thick solid lines – the upper line representing the sensor on top of the mattress and the lower the sensor under the mattress (both in the torso region). The thin solid lines are the temperatures calculated with the proposed mathematical simulation model.



(a)



(b)

**Figure 13.** Moisture conditions for bed A (a) and bed B (b) measured and simulated for both bed systems. One sleeping cycle of 24 hours is shown. Measured temperatures are drawn with thick solid lines – the upper line representing the sensor on top of the mattress and the lower the sensor under the mattress (both in the torso region). The thin solid lines are the vapor contents calculated with the basic mathematical simulation model.

## TABLES

**Table I.** *Material properties for the mattress materials for bed A and bed B.*

<i>Material</i>	<i>Heat conductivity</i> $\lambda$ [W/(m <sup>2</sup> K)]	<i>Specific heat capacity</i> $c$ [J/(kg K)]	<i>Vapor permeability</i> $\delta_v$ [m <sup>2</sup> /s]	<i>Moisture capacity</i> $dw/d\phi$ [kg/m <sup>3</sup> ]
Polyether foam	0.040	1007	25.9 10 <sup>-6</sup>	1.2
Wool batting	0.039	1008	19.5 10 <sup>-6</sup>	9.5
Polyester batting	0.039	-	-	-
Cotton sheet	0.044	-	81 10 <sup>-6</sup>	134

**Table II.** *Thermal conductivities and capacities for the thermal network for the homogeneous bed – bed A*

<i>Conductivity</i>		<i>Capacity</i>	
$K_0$	3.9	$C_1$	626
$K_1$	2	$C_2$	626
$K_2$	2	$C_3$	626
$K_3$	2	$C_4$	626
$K_4$	2	$C_5$	626
$K_5$	2	$C_6$	626
$K_6$	1.7		

**Table III.** Hygric conductivities and capacities for the hygric network for the homogeneous bed – bed A

<i>Conductivity</i>	<i>Capacity</i>
$K_{v,0}$ 0.7	$C_{v,1}$ 1.9
$K_{v,1}$ $2.6 \cdot 10^{-3}$	$C_{v,2}$ 1.4
$K_{v,2}$ $1.3 \cdot 10^{-3}$	$C_{v,3}$ 1.4
$K_{v,3}$ $1.3 \cdot 10^{-3}$	$C_{v,4}$ 1.4
$K_{v,4}$ $1.3 \cdot 10^{-3}$	$C_{v,5}$ 1.4
$K_{v,5}$ $1.3 \cdot 10^{-3}$	$C_{v,6}$ 1.4
$K_{v,6}$ $1.3 \cdot 10^{-3}$	$C_{v,7}$ 1.4
$K_{v,7}$ $2.5 \cdot 10^{-3}$	



**Table IV.** *Thermal conductivities and capacities for the thermal network for the multilayered bed – bed B*

Conductivity		Capacity	
$K_0$	5.1	$C_1$	479
$K_1$	2.8	$C_2$	418
$K_2$	3	$C_3$	418
$K_3$	3	$C_4$	417
$K_4$	2.8	$C_5$	479
$K_5$	1.8	$C_6$	204
$K_6$	1.3		
$K_c = \alpha$	3		
$K_r$	5.1		

**Table V.** *Hygic conductivities and capacities for the hygic network for the multilayered bed – bed B*

<i>Conductivity</i>		<i>Capacity</i>	
$K_{v,0}$	$2.6 \cdot 10^{-3}$		
		$C_{v,1}$	1.9
$K_{v,1}$	$1.6 \cdot 10^{-3}$		
		$C_{v,2}$	8.3
$K_{v,2}$	$1.910^{-3}$		
		$C_{v,3}$	1.0
$K_{v,3}$	$1.9 \cdot 10^{-3}$		
		$C_{v,4}$	1.0
$K_{v,4}$	$2.8 \cdot 10^{-3}$		
		$C_{v,5}$	1.0
$K_{v,5}$	$2.0 \cdot 10^{-3}$		
		$C_{v,6}$	8.3
$K_{v,6}$	$2.5 \cdot 10^{-3}$		
		$C_{v,7}$	0.2
$K_{v,7}$	$2.6 \cdot 10^{-3}$		



**Moisture Buffer Performance of a Fully Furnished Room.**

Svennberg, K., Hedegaard, L. and Rode, C. (2004).

Published in the *Proceedings of the 9<sup>th</sup> International Conference on Performance of the Exterior Envelopes of Whole Buildings*. Clearwater Beach, FL, USA.

© (2004), American Society of Heating, Refrigerating and Air-Conditioning Engineers, Inc. ([www.ashrae.org](http://www.ashrae.org)) Reprinted by permission from ASHRAE.

This material may not be copied nor distributed in either paper or digital form without ASHRAE's permission.



---

# Moisture Buffer Performance of a Fully Furnished Room

Kaisa Svennberg

Lone Hedegaard

Carsten Rode, Ph.D.  
Member ASHRAE

## ABSTRACT

*The moisture buffer capacity of hygroscopic materials can be used to moderate the relative humidity of indoor air as well as moisture content variations in building materials and furnishing. Since moisture plays a significant role in the development of many processes that affect the quality of the indoor air, such as growth of house dust mites, emissions from materials, and mold growth, it is anticipated that the moisture buffer effect can help to ensure healthier indoor environments.*

*Building materials, as well as furniture and other furnishing materials exposed to indoor air, will contribute to the moisture buffer capacity of rooms. Few studies have been made on the impact of furnishing materials in comparison with traditional building materials. This paper will present such a study conducted in a full-scale climatic test cell.*

*A series of experiments have been carried out in the test cell to show the moisture buffer performance of various furnishing objects. The objects will be exposed to cyclic humidity variations as in an inhabited indoor environment, and the response of the indoor humidity will be followed over time. It will be a step-by-step investigation starting with an empty room and going toward a fully furnished room. Comparisons are made with previous studies covering traditional building materials and calculations.*

*The study shows that the furnishings have to be included in the understanding of the moisture buffering performance of a room and that more material data in this area is needed.*

---

## INTRODUCTION

We spend most of our lives indoors and the primary purpose of designing buildings is to ensure good indoor environments for the occupants. This is obtained by interactions between the outdoor conditions, the building envelope, and the occupants. The thermal conditions are already recognized as being important, but moisture is still not considered to be an essential part of building design. In a hygrothermal approach, moisture buffer performance will play an important role. The interactions mean that the surface materials, which are capable of functioning as moisture buffers, are in contact with the indoor air. This study was initiated to increase the knowledge about the interaction between the indoor air and the moisture buffering surface materials. One reason for a growing interest in this topic is a widespread concern for indoor air quality, which to some extent is determined by the level and fluctua-

tions of the humidity of the indoor air (Bornehag et al. 2001). The progress within hygrothermal and energy modeling is another reason for the growing interest in the moisture buffering issue. A literature survey conducted by Harderup (1998) has shown that in order to develop hygrothermal calculation models further, there is a need for a better understanding of the moisture buffer performance of a room, including furniture and furnishings, and more data are also needed concerning moisture properties of the surface materials used in the indoor environment.

Surface materials exposed to variations in the surrounding climate will absorb moisture when the relative humidity (RH) increases and desorb moisture when the RH decreases. This process is referred to as moisture buffering and is to a large extent due to the material composition and structure and to the surface treatment of the material. The moisture buffer capacity of the surface materials in the indoor environment

---

**Kaisa Svennberg** is a Ph.D. student in the Department of Building Physics at Lund Institute of Technology, Lund University, Sweden. **Lone Hedegaard** is a Ph.D. student and **Carsten Rode** is an associate professor in the Department of Civil Engineering and the International Center for Indoor Environment and Energy at the Technical University of Denmark.

will help to minimize the daily variations of RH in the air, which result from the activities of the occupants and the operation of HVAC systems. Both the surfaces of the inside of the building envelope, such as ceilings, floors, and walls, as well as the furniture and other furnishings, have an impact on the moisture conditions in the room. For example, Plathner and Woloszyn (2002) have shown that the correlation between simulated and measured moisture conditions of the indoor air is much better if the sorption of interior surface materials is taken into account.

One benefit of avoiding peaks of high RH is to decrease the risk of condensation on cold surfaces and thereby prevent biological growth. If the RH variations are held within 30% and 60% RH, the growth of allergenic or pathologic organisms can be minimized (ASHRAE 2001). Another advantage is that air with a lower relative humidity will be perceived as being fresher (Toftum and Fanger 1999) due to the increased cooling of the mucous membrane and thereby the increased well-being of inhabitants in the indoor environment. Moist air can also increase the pollutant emissions from materials in contact with indoor air, such as, for example, paints (Fang et al. 1999). These emissions should be avoided in order to keep a good air quality in the indoor environment since work efficiency decreases with rise in air pollution.

The moisture buffer performance is influenced by several material properties—e.g., moisture capacity, water vapor permeability, and the period time of the variations—and today there is no single parameter used to express the moisture buffer performance. A NORDTEST project to deal with this question has been initiated (Rode 2003) and work will be continued to define the moisture buffer performance and to develop standardized measuring methods.

Also, the ventilation and the microclimate influence the moisture buffering performance of the room. The impact of the ventilation depends on the ventilation rate and the vapor content of the indoor and outdoor air. If the ventilation rate is very high, it will control the RH of indoor air to a very high degree. If, on the other hand, the ventilation rate is low, the impact of moisture buffering in surface materials is larger (Christoffersen 1996). The ventilation rate will govern the mean level of RH in the indoor air, and the moisture buffer performance will affect the amplitude of the RH variations. It should be noted that moisture buffering in materials could never replace ventilation, since ventilation also removes heat and sensory and chemical pollution and provides clean air.

To understand the hygrothermal behavior of real rooms is a huge task, which requires a lot of field data and experience about how it can be modeled. Furthermore, the moisture buffer performance is of relevance in many countries worldwide and is much influenced by local climates, the building traditions, and how buildings are used and conditioned in different countries.

Previous research has also been concerned with the moisture buffer performance. In earlier studies the moisture buffer capacity of several materials has been investigated on a small scale (Padfield 1998; Mitamura et al. 2001; Svennberg and

Harderup 2002; Peuhkuri 2003; Ojanen and Salonvaara 2003). In Finland, the moisture buffer capacity of a bedroom was studied in an ecological building without vapor retarder (Simonson 2000; Simonson et al. 2001). In the first investigation it was found that the highest peak humidity in the bedroom could be reduced by up to 20% RH, and the humidity during the winter months could be increased by up to 10% RH. The second investigation concerned the same room exposed to weather data from four different cities, and buffer materials were found to have most impact in a moderate climate such as Scandinavia, and, furthermore, the buffer effect of hygroscopic thermal insulation was strongly reduced when it was not directly exposed. In a comparison between calculations and measurements in a test house, Plathner and Woloszyn (2002) showed that taking into account the impact of the moisture buffering of the surface materials gave a better correlation between measurements and calculations.

The topic of moisture buffer performance has become a part of a newly started international research project, "Whole Building Heat, Air and Moisture Response," which is Annex 41 of the International Energy Agency's (IEA) Energy Conservation in Buildings and Community Systems Programme (Hens 2003). As an IEA activity, it also has the scope to illustrate how a better understanding of the overall hygrothermal behavior of buildings can lead to better energy performance, e.g., by inventing optimized strategies for ventilating, heating, and cooling that take the overall hygrothermal reality of buildings into account.

Most previous research have been conducted on unfurnished rooms, even if the furniture and furnishings of a room to a high extent cover the traditional building materials (Harderup 1998). The scope of this investigation has been to conduct a full-scale experiment with a fully furnished room under well-controlled conditions.

## MATERIALS IN THE INDOOR ENVIRONMENT

Materials used in the indoor environment are a heterogeneous group of materials, from heavyweight concrete used in the building construction to lightweight textiles found in furniture and furnishings.

To ensure durability, facilitate cleaning, and/or for esthetical reasons, the materials of the indoor environment are often surface coated. The surface coatings are often based on polymers, e.g., latex paint, wax, and plastic films. In the indoor environment, surface coatings vary from sparse oil treatments to thick and almost impermeable enamel paints. The moisture resistance of a surface coating is dependent on the material used and the application. If there is a "heavy" surface coating on the top surface of furniture, e.g., a wooden table, usually the bottom will be untreated. The furnishing and furniture also hide the building materials of the building envelope. Therefore, an estimation of the accessibility of indoor air to the potential moisture buffer areas has to be included in an estimate of the moisture buffer performance.

In a preliminary study, Berggren and Skoog (2003) made an inventory of the surface materials present in a dwelling and an office. The comparison between the two buildings showed that in the office, a larger part of the surface materials had a surface coating, and in the dwelling, more untreated wood and textile materials were present (see Figure 1).

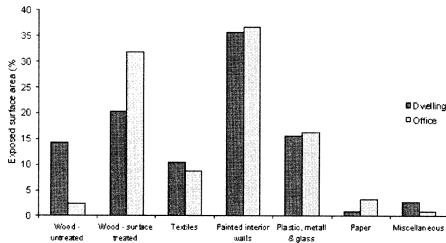


Figure 1 Surface materials—a comparison between a dwelling and an office.

In this study we have concentrated on furniture and furnishings. The materials present in the experiment, as listed in Table 1, were wood with different surface coatings, plastic, textiles, and paper.

### TEST CELL AND EQUIPMENT

The experiments were performed in an airtight and moisture-tight test room. The test facility consists of a highly insulated steel box standing on pillars with an indoor floor area of 13.8 m<sup>2</sup> (149 ft<sup>2</sup>) and room height of 2.75 m<sup>2</sup> (9 ft), giving a volume of 38.0 m<sup>3</sup> (1340 ft<sup>3</sup>). The test cell consists of two rooms, a test room and a service room. The walls are insulated with 0.40 to 0.50 m (16 to 20 in.) of polystyrene and mineral wool and are covered with steel sheets on both the inside and the outside. An exception to this is the south wall, which is exchangeable. During the later experiments the south wall consisted of (from the outside) a wooden cladding, 0.30 m (12 in.) of mineral wool, 0.11 m (4.3 in.) of brick wall, and a polyethylene foil on the inside to provide a vapor-tight and non-absorbing interior surface. A picture and a diagram of the test cells are shown in Figures 2 and 3.

Table 1. Materials Present in the Experiment

Furnishing	Material	Surface Area m <sup>2</sup>	Thickness m	Volume m <sup>3</sup>	Weight kg
Writing desk	Melamine on all surfaces, except wood fiberboard on underside	2.56	0.034	0.041	10.24
Table legs	Wood	0.46		0.007	3.50
Room divider	Two thin sheets of wood fiberboard with 30 12 mm holes and an air cavity in between	1.04	0.038	0.018	4.12
Low plate on wheels	Wood fiberboard with melamine coating	0.42	0.022	0.004	2.64
Bookcase with 1 shelf	Wood with varnish	2.83	0.020	0.026	16.46
Book/accessory case on wheels	Wood with varnish	3.72	0.020	0.034	22.26
Office chair on wheels	Wool, foam plastic, plastic back, metal frame	0.30	0.050	0.015	7.50
Chair seat (for penetration measurements)	Wool, foam plastic, plastic back	0.19	0.050	0.010	
Carpet	Nylon on synthetic rubber backing	4.89	0.003	0.012	2.84
Curtain	Cotton	15.15	0.000	0.003	1.53
Books				0.046	37.20
Paper on desk and in waste basket					
Total		31.56		0.216	108.29



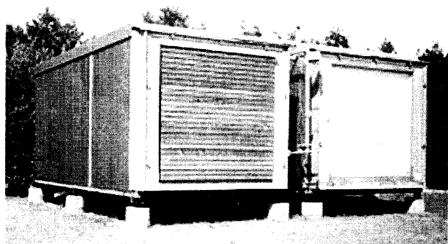


Figure 2 Photo of the test cells.

The test room has an air distribution system connected to the cell's heating and cooling coils. A service room containing the cooling and control systems is placed at the northern end of the test cell. The cell is instrumented with sensors for measuring both the outdoor climate and the indoor conditions (air temperatures, surface temperatures, heating, power used by the cooling system and fans, heat fluxes, air infiltration rate, relative humidity, and air velocity). The indoor relative humidity is measured with capacitive moisture sensors with an accuracy of about  $\pm 2\%$  RH. The data acquisition system is located in an adjacent building, from which the test cell can be controlled.

To measure the moisture buffering effect of the materials in this experiment, the room was subjected to controlled moisture variations. The idea was to mimic the exposure of moisture variations to interior surface materials in a common indoor climate, but in a controlled way. The moisture production was controlled, and the resulting RH variation within the test cell was registered.

The indoor humidification, which represents the moisture production of an inhabited room, was provided by evaporation of moisture from a reservoir of water heated by an electric coil. Humidity was withdrawn from the air by a dehumidifier draining into the same reservoir. The drying represents the removal of humidity from the room that would normally take place by ventilation.

The water reservoir was suspended in a load cell, and the rates of humidification and drying were controlled according to a predefined schedule. Padfield (1998) has used the principle in a small ( $0.5 \text{ m}^3$ ,  $18 \text{ ft}^3$ ) test chamber in a laboratory. A schematic diagram of the apparatus is shown in Figure 4.

Another similar load cell, as for the water reservoir, was suspended in a rack from which a material specimen could be weighed continuously during the tests. The range and accuracy of the load cells was  $10 \text{ kg} \pm 3 \text{ g}$  ( $22 \pm 0.007 \text{ lb}$ ).

Two small fans were placed on the floor at both ends of the test cell to ensure a well-mixed airflow. The control system was set to save registered average data for a ten-minute period of measurements with sampling every thirty seconds.

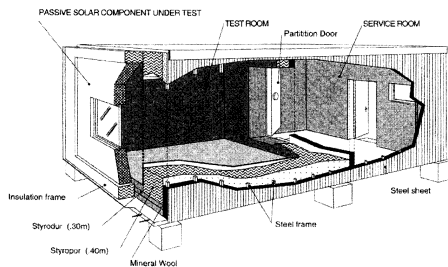


Figure 3 Diagram of the test cells.

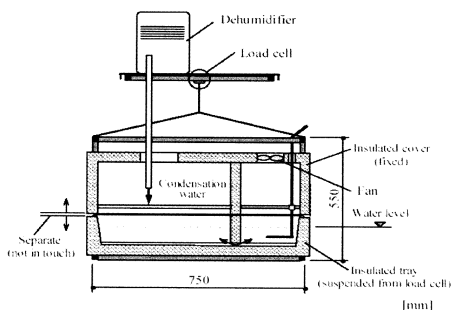


Figure 4 A schematic diagram of the climatic control system of the test chamber.

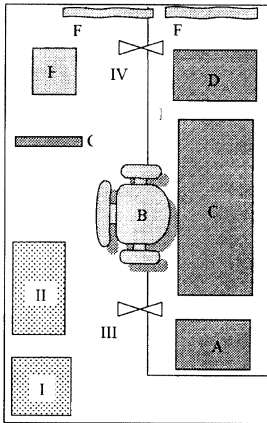
The air change rate of the test cell has been measured with tracer gas using the decay method and found to be about  $0.20 \text{ h}^{-1}$  at  $50 \text{ Pa}$  ( $0.015 \text{ in. Hg}$ ) pressure difference. Without pressurization the air change rate was about  $0.007 \text{ h}^{-1}$  (Mita-mura et al. 2001).

## MEASUREMENTS

This paper explains two sets of measurements in the test cell. The main experimental set presented for the purpose of this paper deals with the effect of furniture and other furnishing in a room to buffer the indoor humidity variations. For comparison, this is followed by a short presentation of a former study in the same equipment, where the moisture buffer effect of different interior wall systems was investigated.

### Fully Furnished Room

In this investigation the relative humidity variation in an office was investigated. During the experiments the daily variation in the test cell was humidification and dehumidification moisture load of  $33 \text{ g}$  water per hour ( $1.2 \text{ oz}$  per hour) and an isothermal temperature of  $20.0 \pm 0.5^\circ\text{C}$  ( $68 \pm 1^\circ\text{F}$ ).



**Figure 5** A schematic diagram of the test cell.

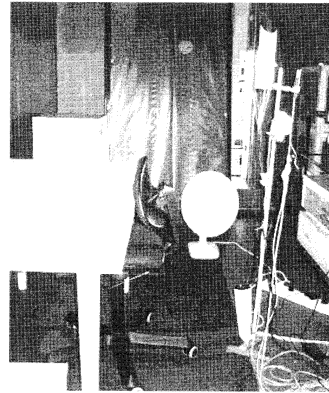
The experiment concerned nine different cases. Cases 1 and 9 were both performed for the empty test cell as reference tests. Case 2 comprises the basic furniture of an office, with a desk, a room divider, an office chair and chair seat, a computer shelf, and a rolling shelf. In case 3 books were added in the shelves. A carpet was applied in case 4. Case 5 was a real office situation with papers in the wastebasket and spread over the table. Finally, a curtain was added to the test cell in case 6. The placement in the fully furnished test cell is shown in Figures 5 and 6.

The following cases were a gradual emptying of the test cell. In case 7 the curtain, the paper on the table, and the carpet were removed. In case 8 the books was removed, and in case 9 the test cell were empty except for the chair seat used for the penetration measurements.

### Penetration Measurements

A chair seat was used for moisture penetration measurements. The chair seat was from an industrially manufactured chair and consisted of a 5 mm (0.2 in.) plastic board, 31 mm (1.2 in.) foam plastic, and a wool fabric as a cover. The plastic board was covered underneath with a nonwoven synthetic fabric.

Four combined temperature and relative humidity sensors were applied. The first sensor was placed between the plastic board and the foam plastic in the center of the seat. The second sensor was placed halfway down in the foam plastic and the third sensor on top of the foam plastic but under the wool fabric. The fourth and last sensor was placed on top of the wool



**Figure 6** Placement in the fully furnished test cell.

fabric. The sensors were somewhat displaced so that interference from the other sensors was minimized.

The chair seat was suspended in the specimen load cell in the test room.

### Interior Walls

A previous experiment (Hedegaard 2002) studied the moisture buffer capacity of an interior wall. In the setup the daily moisture load was set to evaporation at a constant rate of 25g/h (0.88 oz/h) for half a day followed by a similar period with condensation at the same rate. The experiments were performed under isothermal conditions of  $21.0 \pm 0.5^\circ\text{C}$  ( $70 \pm 1^\circ\text{F}$ ).

The inner wall consisted of a steel frame with insulation inside. The thickness of this basic part of the wall layer was 70 mm (2.8 in.). In cases 2 and 3 measurements were made with mineral wool as insulation or, alternatively, with loose fill cellulose insulation ( $65 \text{ kg/m}^3$ ,  $4.0 \text{ lb/ft}^3$ ). A metal wire netting was added in order to keep the cellulose insulation in place. The following cases were only made with cellulose insulation. In case 4 untreated plasterboards were added on each side of the construction. The thickness of the plasterboard was 13 mm. In case 5 painted plasterboards replaced the untreated plasterboards. The painting consisted of two coats of latex wall paint. Finally, in case 6, a vapor retarder was added between the insulation and the painted plasterboards, although this is not normal to have in an interior wall. During all the experiments, moisture transport through the edges of the test walls was prevented by use of moisture proof tape. The exposed surface areas for each case are given in Table 3.

**Table 2. Types of Furniture/Furnishing Exposed**

Case	Furniture - Table - Chair - Room divider - Shelf 1 - Shelf 2	Books	Carpet	Paper on Table	Curtain
1 (empty)					
2	*				
3	*	*			
4	*	*	*		
5	*	*	*	*	
6 (fully furnished)	*	*	*	*	*

**Table 3. Exposed Surface Areas**

Case	Material	Exposed Surface Area, m <sup>2</sup>
1	Empty test cell	0.0
2	Mineral wool in steel frame	15.38 (166 ft <sup>2</sup> )
3	Cellulose insulation in steel frame	15.38 (166 ft <sup>2</sup> )
4	Cellulose insulation in steel frame under untreated plasterboards	20.15 (217 ft <sup>2</sup> )
5	Cellulose insulation in steel frame under painted plasterboards	20.24 (218 ft <sup>2</sup> )
6	Cellulose insulation in steel frame under vapor retarder and painted plasterboards	20.24 (218 ft <sup>2</sup> )

**CALCULATIONS**

The indoor humidity has also been modeled with a whole-building hygrothermal simulation tool (Rode and Grau 2003; Rode et al. 2001). The tool is capable of making transient prediction of the heat and moisture condition of materials in the building envelope and in indoor furnishings and simultaneous prediction of the humidity condition of the indoor air. Significant in this modeling is to see how the hygroscopic materials are able to moderate the variations of the indoor humidity. The scope of the modeling was to see if it could be possible to predict the effect of various items in indoor furnishing to act as moisture buffers and possibly to use the experimental results just presented to benchmark the model.

The calculation tool uses a finite control volume method and models the hygroscopic absorption of moisture in materials according to their sorption curve. In doing so, it also models the hysteresis that characterizes the difference between the sorption curves for absorption and desorption, and it models the so-called scanning curves that are followed in the transition between absorption and desorption. Moisture transport within the materials is modeled as vapor diffusion according to Fick's law. The heat and vapor transport coefficients at the surfaces of materials in the room are modeled with constant surface resistances: 0.13 m<sup>2</sup>K/W (0.74 ft<sup>2</sup>·h·°F/Btu) for heat transfer and 5.1·10<sup>7</sup> Pa·m<sup>2</sup>·s/kg (corresponding to a permeability of 340 perm) for vapor transfer.

To model the materials in indoor furnishings, e.g., an office chair or the books on a shelf, it is necessary to approximate these elements with planar construction surfaces, just like inner walls. Thus, it must be realized that even the relatively simple test chamber and furnishings that were analyzed in these tests can only be simulated using some rough approximations about how the materials should be represented in the model. It is not possible with the calculation model used to represent the real microclimatic conditions near the surfaces of the objects in the room. However, to get some indication of the influence of the boundary conditions in the interface between furnishing and indoor air, a simulation was also carried out for the fully furnished room when the surface resistance for vapor transfer was doubled to the value 1.02·10<sup>8</sup> Pa·m<sup>2</sup>·s/kg. This had the effect of increasing the amplitude of the daily indoor RH variation from about 21.6% RH to 22.8% RH, i.e., a relative increase in the order of 5%. This must be seen only as an indicative number since it depends on the choice of materials and their aerial configuration in the room. More research is needed into the importance of the surface mass transfer coefficient and the microclimatic conditions around indoor furnishings is needed.

Some simulation models were set up to predict the indoor humidity variation in different cases, from the empty test cell to the test cell fully furnished as an office with a desk with working papers, upholstered office chair, book cases with books on the shelves, a carpet, and curtains. The modeled

setting was the same as in the experiments described previously. The room was the well-insulated steel box, which is practically inert to moisture flow through its walls and is very airtight. A humidification of the room of 33 g/h (1.2 oz/day) was simulated for 12 hours followed by a dehumidification of the same magnitude for the other 12 hours per day. The indoor air temperature was modeled so it was constant at 20°C (68°F). The materials of the furniture were entered into the simulation model as multi-layered structures of homogenous material layers—sometimes down to a control volume thickness of around 0.1 mm (4 mil). The numerical grid was expanding, so the surface control volumes were thinner than control volumes deeper in the material. The calculations were carried out for one-week periods, where each day was calculated under identical assumptions. All materials started at a moisture content corresponding to a given initial relative humidity. This value was chosen to match as closely as possible the same conditions as in the experiments.

## RESULTS

### Comparison: Empty Room—Fully Furnished

The difference in the moisture buffer performance between the fully furnished test room and the empty test room can be seen in Figures 7 and 8. The two cases have approximately the same average RH (55% resp. 57% RH) but the fully furnished room has a smaller amplitude. A smaller amplitude indicates a larger moisture buffer capacity in the surface materials if the ambient conditions are similar in the cases compared, as in these experiments. For a one-day variation, the fully furnished room has a highest peak of humidity 10% RH lower than it was for the empty room, and the daily minimum value is 5% RH higher than for the empty room. Overall, this gives a less varying indoor climate. Comparing all the different cases (see Table 2 and Figure 8) it can be noted that the cases where lightweight organic materials, such as papers and textiles, are exposed have the lowest variation in RH for these weekly sequences of daily variations.

### Penetration Measurements

The result of the measurement of moisture penetration into the chair seat that was used as a weighed specimen indicates that moisture penetration into the seat progresses almost instantaneously. Although there is a small time-delay for the moisture variation, it depends on the distance from the top surface. This is easiest to see when the change in RH is plotted as a function of time and at the lowest value for the moisture variation (see Figure 9). The upper half of the chair seat has a larger moisture variation.

It can also be noted that the effect of the disturbances, mainly from the control system of the humidification/dehumidification system, decreases with the distance from the top, as expected. In the bottom half of the chair seat, the sensors register almost no disturbances in comparison to the sensors on top of and just underneath the wool fabric.

## Comparison Measurements and Calculations

Figure 7 shows the measured variation of indoor relative humidity for one typical day for the room without materials, as well as for the fully furnished room. For the empty room, the relative humidity varies between approximately 35% and 80% RH, while for the fully furnished room it varies between 40% and 70% RH. For the empty room, this corresponds to a variation in humidity ratio of the air between 5.1 g/kg and 11.7 g/kg (at 20°C, 68°F) and between 5.8 and 10.2 g/kg for the fully furnished room. The theoretical variation in indoor humidity ratio should be  $\pm 8.7$  g/kg for the empty room when the as-planned 33 g/h (1.2 oz/day) of moisture are added to and withdrawn from the 38 m<sup>3</sup> (1340 ft<sup>3</sup>) test cell in 12-hour periods. These results illustrate some deficits of the experimental configuration: The dehumidifier used to withdraw humidity from the air had some difficulty in desiccating the air significantly below 40% RH, so not all the planned humidity variation could be realized. Further, it may be possible that there was some hygroscopic absorption of moisture in the paint, polyethylene sheets, dust, and electrical wires in the otherwise empty room.

The same figure shows the results of the calculation of indoor humidity. The simulation result for the empty room shows a variation between 26% and 88% RH, while it varies between 45% and 66% RH for the fully furnished room.

### Interior Walls

The results of indoor RH variation with inner walls as moisture buffers are shown for representative one-day periods in Figure 10. The experiments show that cellulose insulation has a very good buffering effect. In a small office with a 15 m<sup>2</sup> (166 ft<sup>2</sup>) buffer wall of cellulose insulation the variation range of relative humidity can be reduced to half the variation in a similar room with non-absorbing materials. On the other hand, the moisture buffer capacity for mineral wool has been found to be very small. It was also found that if plasterboards cover the insulation in an interior wall, the moisture buffer capacity of the insulation is insignificant.

For the three cases with plasterboards it is hard to differentiate between the moisture buffer capacities. The curves for the two painted plasterboards are very similar. This seems reasonable since the penetration depth for the untreated plasterboard was less than the 13 mm (0.5 in.) thickness of the plasterboards so the test results were expected to be identical. The resulting error was 10% and thereby it seems fair that the two test series are alike. However, this also means that it is impossible to distinguish between the test with the untreated plasterboard and the tests with the painted plasterboards. The plasterboards have a moisture buffer effect somewhere between that of mineral wool and that of cellulose insulation.

## DISCUSSION

The moisture buffer capacity of the surface materials of the indoor environment can be used to minimize the daily peak variations of relative humidity in the air and thereby avoid periods with both very high and very low relative humidity. As

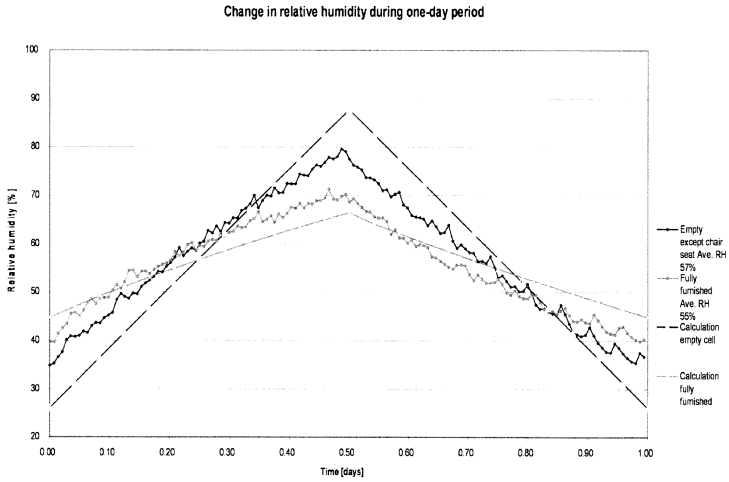


Figure 7 Difference in the moisture buffer performance between the fully furnished test room and the empty test room.

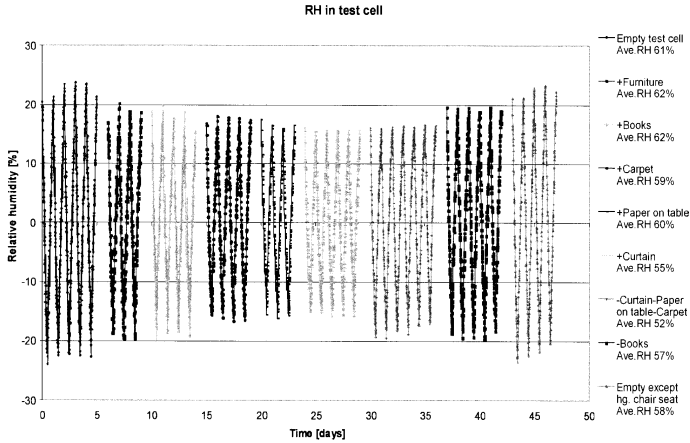


Figure 8 The variation in RH for the nine different cases for the furnished room experiments.

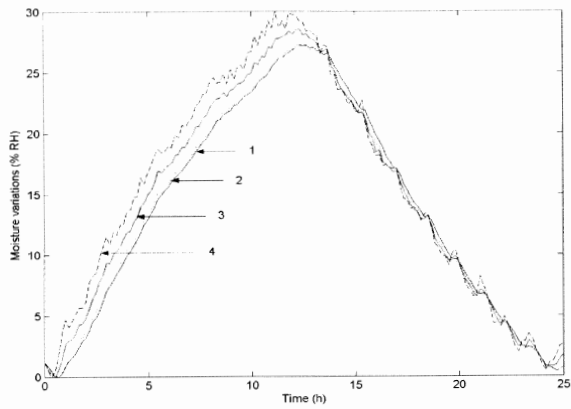


Figure 9 The moisture variation in the chair seat.

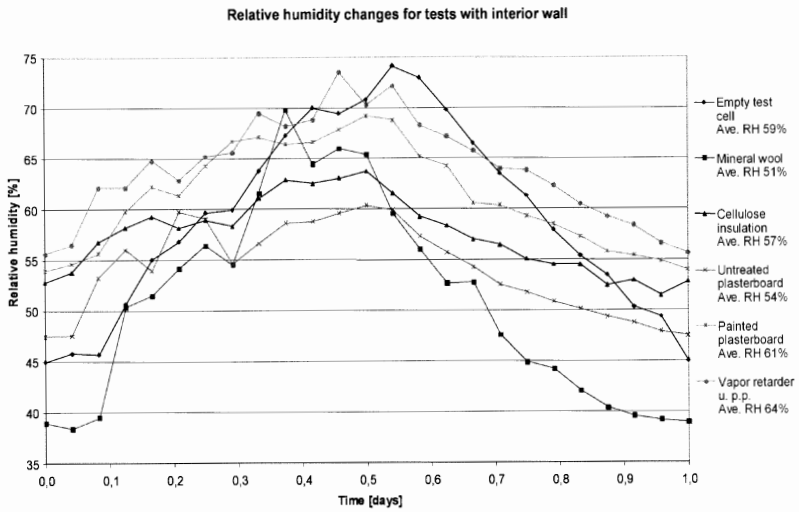


Figure 10 The results of indoor RH variation with inner walls as moisture buffers are shown for representative one-day periods.

mentioned in the introduction, there are many advantages. Reducing the highest appearing RH in the indoor air reduces the risk of condensation on cold surfaces and the number of emissions from surface treatments and causes the air to be perceived as fresher. The reduction of the high peak values is advantageous for both the constructions and the indoor air, since fungal growth and consequent deterioration and spread of spores are less likely to appear.

To play an active role in minimizing the daily peak variations, the materials in the indoor environment need to be relatively open and have a moisture buffer capacity together with a sufficient exposed area. In this experiment it has been shown that a fully furnished room has a better moisture buffer performance than a sparsely furnished room. Highly permeable and lightweight materials, such as papers and textiles, play an important role in moderating the hourly or daily variations, since to a high degree they cover other materials, such as surface-treated wooden book shelves or painted interior walls. There is a need for moisture properties for surface materials, both traditional building materials and materials for furnishing, and special interest should be paid to surface treatments such as lacquers and paint. The results from the experiment with the interior walls indicate that a further investigation in the field of paint coverings should be carried out. A larger survey of the materials present in the indoor environment is another topic for further research, which can be used to describe the indoor environment in a more precise way.

To model the indoor humidity of rooms while taking into account the moisture absorption in surfaces of the objects in the room requires detailed knowledge about the surface area, texture and topology of the surfaces, as well as knowledge about the material properties and the local surface coefficients for convective moisture flow at the different loci where humidity exchange takes place. Regarding these properties for real rooms with all their gadgets or even a simplified setup like the test cell investigated in this work, it is obvious that it will become an immense, or even impossible, task to achieve high precision in the provision of these data. The work illustrated in this paper has shown that it is possible to some extent to model the conditions in a room under simplified and idealized assumptions. By comparison of test cell and field test data, it should be possible to obtain good guidelines on how the complex layout of a room can be modeled in a way that merges all objects into a limited number of idealized surfaces. In addition, it should be possible by studying the microclimates in some characteristic material/air interfaces and analyzing these (e.g., with CFD calculation) to get a better understanding of the local mechanisms for heat and moisture exchange in such loci.

A large source of uncertainty in the experiments and calculations presented here is the surface moisture transfer coefficient, which to a high extent is governed by the microclimate at each location. We lack knowledge about the true microclimate and this has to be more carefully studied, as mentioned above. Also, the effective exposed surface areas introduce uncertainties into the experiments and calculations,

and a methodology to determine the effective exposed surface area has to be carefully thought through.

The comparison between calculations and measurements as shown in the "Results" section and in Figure 7 illustrates some deficits of the experimental configuration. The dehumidifier used to withdraw humidity from the air had some difficulty in desiccating the air significantly below 40% RH, so not all the planned humidity variation could be realized. The possibility of some hygroscopic absorption of moisture in the paint, polyethylene sheets, dust, and electrical wires in the otherwise empty room poses another potential source of error.

The usefulness of this type of controlled full-scale measurement should still be considered very high, since it provides an important step between calculations and laboratory measurements on one hand and field measurements in real environments on the other hand. Especially this type of test cell with an exchangeable wall (see Figure 3) provides an advantage when future experiments can be done more realistically by conducting non-isothermal tests with a naturally varying indoor climate due to solar gain.

In the IEA Annex 41 project (described in the introduction) there will be activities that seek to gather as much field and test case information as possible from the different participating countries such that a broad knowledge base will be obtained. It is also anticipated that common exercises will be carried out where the modeling capabilities will be benchmarked and further developed. It appears obvious that the effect of furniture and other indoor materials to moderate the indoor humidity will be a part of this international study.

Altogether, it should be possible to establish a better empirical and analytical understanding of how a real room with all its furnishings performs to buffer the indoor humidity. The work presented in this paper may be seen as an early step on the path to improving this understanding.

## CONCLUSION

The full-scale measurements of a fully furnished room have shown that moisture buffering needs to be more carefully studied since it has a notable impact on the moisture conditions in rooms. Calculation tools need to be modified to be able to handle, not only traditional building materials, but also furniture and other furnishing materials. There is also a lack of data for the moisture properties of the surface materials in the indoor environment. Also, a description of different surface materials present in normal indoor environments is needed. Alongside the task to find better descriptions of the materials, a better understanding and greater knowledge of the microclimate indoors is necessary.

## ACKNOWLEDGMENTS

Support from IKEA is gratefully acknowledged. We thank J. Schultz, DTU, for valuable technical assistance and Dr. L. Wadsö, LTH, for experimental help. The work was carried out in part with support of the Technical Research Council of Denmark and FORMAS-The Swedish Research Council for Environment, Agricultural Sciences and Spatial Planning.

## REFERENCES

- ASHRAE. 2001. *ANSI/ASHRAE Standard 62-2001, Ventilation for acceptable indoor air quality*. Atlanta: American Society of Heating, Refrigerating and Air-Conditioning Engineers, Inc.
- Bornehag, C.-G., G. Blomquist, F. Gynteborg, B. Järholm, P. Malmberg, L. Nordvall, A. Nielsen, G. Pershagen, and J. Sundell. 2001. Dampness in building and health, review article. *Indoor Air* 11:72-86.
- Berggren, T., and H. Skoog. 2003. Materials in the indoor environment—A preliminary study (in Swedish). Department of Building Physics, Lund University, unpublished report.
- Christoffersen, L.D. 1996. ZEPHYR passive climate controlled repositories. Department of Building Physics, Lund University, Report TVBH-3028.
- Fang, L., G. Clausen, and P.O. Fanger. 1999. Impact of temperature and humidity on chemical and sensory emissions from building materials. *Indoor Air* 9:193-201.
- Harderup, L-E. 1998. Hygroscopic moisture of the indoor air considering non-stationary phenomena. Synthesis of publications for the period 1979-1998 (in Swedish). Department of Building Physics, Lund University, Report TVBH-3033.
- Hedegaard, L. 2002. Moisture buffer capacity of building materials. M.Sc. thesis, Department of Civil Engineering, Technical University of Denmark.
- Hens, H. 2003. Whole building heat, air and moisture response (MOIST-ENG). Proposal for a new annex; International Energy Agency, EXCO Energy Conservation in Buildings and Community Systems. Department of Civil Engineering, KU-Leuven, Belgium.
- Mitamura, T., C. Rode, and J. Schultz. 2001. Full-scale testing of indoor humidity and moisture buffering in building materials. CD, *Conference Proceedings IAQ 2001, Moisture, Microbes, and Health Effects: Indoor Air Quality and Moisture in Buildings*. Atlanta: American Society of Heating, Refrigerating and Air-Conditioning Engineers, Inc.
- Ojanen, T., and M. Salonvaara. 2003. A method to determine the moisture buffering effect of structures during diurnal cycles of indoor air moisture loads. *Research in Building Physics*, eds. Carmeliet, Hens, and Vermeir, pp. 353-361. Lisse: Swets & Zeitlinger, ISBN 90 5809 565 7.
- Padfield, T. 1998. The role of absorbent materials in moderating changes of relative humidity. Report R-054, Department of Structural Engineering and Materials, Technical University of Denmark.
- Peuhkuri, R. 2003. Moisture dynamics in building envelopes. Report R-071, Department of Civil Engineering, Technical University of Denmark.
- Plathner, P., and M. Woloszyn. 2002. Interzonal air and moisture transport in a test house. Experiment and modeling. *Buildings and Environment* 37: pp. 189-199.
- Rode, C. 2003. Nordtest Workshop on Moisture Buffer Capacity—Summary Report. DTU, Lyngby, Denmark.
- Rode, C., and K. Grau. 2003. Whole-building hygrothermal simulation model. *ASHRAE Transactions* 109(1).
- Rode, C., K. Grau, and T. Mitamura. 2001. Hygrothermal conditions in the envelope and indoor air of buildings. *Performance of Exterior Envelopes of Whole Buildings VIII CD*. Atlanta: American Society of Heating, Refrigerating and Air-Conditioning Engineers, Inc.
- Simonson, C.J. 2000. Tapanila ecological house. VTT Building Technology, Technical Research Centre of Finland.
- Simonson, C.J., M. Salonvaara, and T. Ojanen. 2001. Improving indoor climate and comfort with wooden structures. VTT Building and Transport, Technical Research Centre of Finland.
- Svennberg, K., and L-E. Harderup. 2002. Time-dependent moisture properties for plasterboard with surface coating. *Indoor Air* 2002.
- Toftum, J., and P.O. Fanger. 1999. Air humidity requirements for human comfort. *ASHRAE Transactions* 105(2): 641-647.





# Dissertations from Building Physics, Lund University, Sweden

Bankvall C G	Natural Convective Heat Transfer in Insulated Structures. Report 38. Heat Transfer in Insulation and Insulated Structure. Report 39.	1972
Sandberg P-I	Moisture Balance in Building Elements Exposed to Natural Climatic Conditions. Report 43. (in Swedish)	1973
Bomberg M	Moisture Flow through Porous Building Materials. Report 52.	1974
Samuelsson I	Moisture Transfer in Steel Deck. Report 67. (in Swedish)	1976
Andersson A-C	Internal Additional Insulation. Thermal Bridges, Moisture problems Movements and Durability. TVBH-1001. (in Swedish)	1979
Kronvall J	Air Flows in Building Components. TVBH-1002.	1980
Jóhannesson G	Active Heat Capacity. Models and Parameters for the Thermal Performance of Buildings. TVBH-1003.	1981
Hagentoft C-E	Heat Loss to the Ground from a Building. Slab on the Ground and Cellar. TVBH-1004.	1988
Harderup L-E	Concrete Slab on the Ground and Moisture Control. Verification of some Methods to Improve the Moisture Conditions in the Foundation. TVBH-1005.	1991
Bornehag C-G	Mönsteranalys av inomhusluft – Undersökning av luftkvalitet i sjuka hus med flytspackelproblem. BFR Report no R23:1994. Swedish Council of Building Research. Stockholm. (in Swedish)	1994
Blomberg T	Heat Conduction in Two and Three Dimensions. Computer Modelling of Building Physics Applications. TVBH-1008.	1996
Roots P	Heat Transfer through a Well Insulated External Wooden Frame Wall. TVBH-1009.	1997
Arfvidsson J	Moisture Transport in Porous Media. Modelling Based on Kirchhoff Potentials. TVBH-1010.	1998

Harderup E	Methods to select corrections for moisture calculations at variable external climatic data. TVBH-1011 (in Swedish)	1998
Adalberth K	Energy Use and Environmental Impact of New Residential Buildings. TVBH-1012.	2000
Engdahl F	Air – for Health and Comfort. An Analysis of HVAC Systems' Performance in Theory and Practice. TVBH-1013	2002
Johansson D	Modelling Life Cycle Cost for Indoor Climate Systems. TVBH-1014	2005
Hägerhed Engman L	Indoor environmental factors and their association with asthma and allergy among Swedish pre-school children. TVBH-1015	2006
Svennberg K	Moisture Buffering in the Indoor Environment. TVBH-1016	2006