



LUND UNIVERSITY

Islanding Detection in Power Systems

Stråth, Niklas

2005

[Link to publication](#)

Citation for published version (APA):

Stråth, N. (2005). *Islanding Detection in Power Systems*. [Licentiate Thesis, Industrial Electrical Engineering and Automation]. Department of Industrial Electrical Engineering and Automation, Lund Institute of Technology.

Total number of authors:

1

General rights

Unless other specific re-use rights are stated the following general rights apply:

Copyright and moral rights for the publications made accessible in the public portal are retained by the authors and/or other copyright owners and it is a condition of accessing publications that users recognise and abide by the legal requirements associated with these rights.

- Users may download and print one copy of any publication from the public portal for the purpose of private study or research.
- You may not further distribute the material or use it for any profit-making activity or commercial gain
- You may freely distribute the URL identifying the publication in the public portal

Read more about Creative commons licenses: <https://creativecommons.org/licenses/>

Take down policy

If you believe that this document breaches copyright please contact us providing details, and we will remove access to the work immediately and investigate your claim.

LUND UNIVERSITY

PO Box 117
221 00 Lund
+46 46-222 00 00

Islanding Detection in Power Systems

Niklas Stråth



LUND UNIVERSITY

Licentiate Thesis

Department of Industrial Electrical Engineering
and Automation

2005

Department of
Industrial Electrical Engineering and Automation
Lund University
P.O. Box 118
SE-221 00 LUND
SWEDEN

<http://www.iea.lth.se>

ISBN: 91-88934-42-X

CODEN: LUTEDX/TEIE-1051/1-129/(2005)

©Niklas Stråth, 2005
Printed in Sweden
Lund University
Lund, 2005

Per Aspera Ad Astra.

Abstract

As the contribution of dispersed or distributed energy resources (DER) to the electric power production increases, the effects on the power system grow more important. As an example a critical situation may arise if protective relays trip a large part of the dispersed generation due to undervoltage at a short-circuit event. On the other hand it is crucial that the protection system acts correctly to protect life and property in other situations. These qualities are referred to as security and dependability.

There are a number of different kinds of anti-islanding or loss-of-mains protections. Some are implemented in practice while others are still on a research level. This thesis provides an analysis of benefits and drawbacks of methods that are applied today. The ability of the different methods to avoid nuisance tripping and provide robust protection is investigated.

To draw the attention to industrial experience, some cases are described where dispersed generations were nuisance tripped. Recordings from islanding events are presented and analyzed. Performance of present anti islanding protections is commented.

A comparison of grid codes in Sweden, Denmark and Germany serves as an example of the situations in different countries. Today there are differences in the connection requirements depending on different designs of the distribution systems. These varying requirements lead to different demands on the islanding detection devices. The thesis summarizes the technical requirements on the islanding portion of the protection system.

To compare the protection algorithms, they are exposed to challenging situations in a common simulation environment. In the simulation model, a DER-unit (induction generator) is connected to a typical distribution grid. The grid consists of two 20 kV feeders connected to a 130 kV network equivalent via a common bus bar and a transformer. Additional feeders are modeled with generic load and shunt capacitances.

The concept of distributed energy resources is moving from being a local issue towards a system issue. The islanding protection devices being used in the future have to reflect this. The thesis aims at describing this process and ends with a list of possibly unresolved issues.

Acknowledgements

Everyone who has been struggling with a thesis work knows that it not is possible to finish without support. I have received help and encouragements from many.

First I sincerely want to thank Dr. Olof Samuelsson, who hired me and became my supervisor. Over the time he has introduced me to the academic world. He has also supported me during the work and given me excellent feedback on my work when I have delivered it. I am most grateful!

I am very thankful to my assistant supervisor Professor Sture Lindahl. His long experience with power systems has been an inexhaustible source of information and he has always been able to answer my questions.

I am also very thankful to my other assistant supervisor Professor Gustaf Olsson. His perspective on my work has inspired me to go on.

The members of the steering committee have generously shared their thoughts and ideas as well as field experience at our meetings. They pointed out the direction and I am very thankful to all of them. Thank you Dr. Magnus Akke, Professor Lars Gertmar, Åke Juntti, John Eli Nielsen and Dr. Jan Svensson.

I owe Dr. Morten Hemmingsson a lot of thanks for interesting discussions over many lunches and for helping me with Matlab.

To the colleges at the department I would like to say thank you for being there. I want to direct a special thank to Fredrik Roos, Dr. Ines Romero Navarro and Dr. Dalius Misiunas, with whom I shared room. You helped me to put things in perspective.

When I applied for the position I was employed at Carl Bro AB. I would like to thank my boss György Sarosi for giving me leave of absence.

I would also like to thank all the colleges I met in the power system world during my first years after graduation. Your introduction to the field was important to me and I am most grateful.

My father Professor Bo Stråth and my mother Maud Stråth have always encouraged me to seek answers to my many questions. I owe the curiosity that made me start this journey to them. Thanks!

In the last years I have discovered that I am a very rich man, though my banker would probably not agree. I have many good and close friends and that's a real fortune. I will not mention you by name (as you know I tend to forget names), but you know who you are. Thanks for being there for me when I need you!

This work has been financed by *Delegationen för Energiförsörjning i Sydsverige, DESS*, which is greatly acknowledged.

Lund, 23 November 2005

Niklas Stråth

Contents

CHAPTER 1 INTRODUCTION.....	1
1.1 MOTIVATION	1
1.2 OBJECTIVES	4
1.3 OUTLINE OF THE THESIS	5
1.4 CONTRIBUTIONS	6
CHAPTER 2 DISTRIBUTED ENERGY RESOURCES.....	7
2.1 DISTRIBUTED ENERGY RESOURCES	7
2.2 ENERGY SOURCES	8
2.3 ENERGY STORAGE	10
2.4 ENERGY CONVERTERS.....	10
2.5 POWER SYSTEM IMPACT	11
2.6 ISLANDING.....	13
2.7 PROTECTION SYSTEMS	14
2.8 ISLANDING DETECTION.....	15
CHAPTER 3 GRID CODES	17
3.1 AMP.....	17
3.2 SVENSKA KRAFTNÄT	18
3.3 ELTRA.....	21
3.4 E.ON NETZ GMBH.....	24
3.5 IEEE STANDARD 1547-2003.....	27
3.6 SUMMARY	28
CHAPTER 4 METHODS FOR ISLANDING DETECTION	29
4.1 PASSIVE METHODS	29
4.2 ACTIVE METHODS.....	35
4.3 METHODS USING COMMUNICATION	36
CHAPTER 5 SIMULATION MODEL	39

5.1	SYSTEM	39
5.2	STRONG GRID	40
5.3	TRANSFORMER	40
5.4	LINES	41
5.5	LOADS	41
5.6	POWER PLANT	42
CHAPTER 6 SIMULATIONS		45
6.1	ISLANDING WITH PART OF THE 130 kV GRID	46
6.2	ISLANDING WITH THE 20 kV FEEDER	53
6.3	ÅTRAN ISLANDING EXPERIMENT	57
6.4	PARALLEL CONNECTION OF TRANSFORMER.....	60
6.5	CAPACITOR SWITCHING.....	64
6.6	LOSS OF BULK POWER PRODUCTION	67
6.7	SHORT-CIRCUIT AT THE 130 kV LEVEL	69
6.8	SHORT-CIRCUIT IN THE 20 kV TRANSFORMER BAY	74
6.9	SHORT-CIRCUIT IN AN ADJACENT FEEDER.....	79
6.10	SUMMARY	81
CHAPTER 7 VOLTAGE MEASURING RELAYS.....		83
7.1	SETTINGS	83
7.2	ISLANDING.....	87
7.3	SWITCHING.....	87
7.4	SHORT-CIRCUITS	88
7.5	SUMMARY	88
CHAPTER 8 FREQUENCY MEASURING RELAYS		91
8.1	SETTINGS	91
8.2	ISLANDING.....	93
8.3	SWITCHING	96
8.4	SHORT-CIRCUITS	97
8.5	SUMMARY	97
CHAPTER 9 VECTOR SHIFT RELAYS		99
9.1	SETTINGS	99
9.2	ISLANDING.....	100
9.3	SWITCHING.....	100
9.4	SHORT-CIRCUITS	100
9.5	SUMMARY	101

CHAPTER 10 METHODS USING COMMUNICATION.....	103
10.1 SETTINGS	103
10.2 ISLANDING.....	104
10.3 SWITCHING.....	105
10.4 SHORT-CIRCUITS	106
10.5 SUMMARY	106
CHAPTER 11 DISCUSSION	107
CHAPTER 12 CONCLUSIONS	109
12.1 FINDINGS	109
12.2 FUTURE WORK.....	110
REFERENCES	111

Abbreviations and definitions

AVR	Automatic voltage regulator
CHP	Combined heat and power
COROCOF	Comparison of rate of change of frequency
Dependability	The probability for a protection of not having a failure to operate under given conditions for a given time interval.
DER	Distributed energy resource
DG	Distributed generation
DR	Distributed resource
Dropout	A term for contact operation (opening or closing) as a relay just departs from pickup. Also identifies the maximum value of an input quantity that will allow the relay to depart from pickup.
Dropout ratio	The ratio of dropout to <i>pickup</i> of an input quantity.
EPS	Electric power system
f	Frequency
f_n	Nominal frequency
f_{rated}	Rated frequency
H	Inertia constant
HV	High voltage, voltages above 35 kV AC.
LOM	Loss of mains
LV	Low voltage, voltages less than 1 kV AC.

MV	Medium voltage, voltages between 1 and 35 kV AC
n	Mechanical speed
n_n	Nominal mechanical speed
n_s	Synchronous speed
Operating time	The time interval from fault inception until the protection operates
P	Active power
p.u.	Per unit
PCC	Point of common coupling
PEC	Power electronic converter
Pickup	The action of a relay as it makes designated response to progressive increase of input.
PLL	Phase-locked loop
PMU	Phasor measurement unit
Primary distribution system	The part of the distribution system containing medium voltage equipments.
Q	Reactive power
Reliability	The probability that a protection can perform a required function under given conditions for a given time interval.
Ride-through capability	The ability of equipment to withstand momentary interruptions or <i>sags</i> .
rms	Root mean square
ROCOF	Rate of change of frequency
Sag	Momentary undervoltage at fundamental frequency lasting from a half-cycle to a few seconds.
SCADA	Supervisory control and data acquisition
Secondary distribution system	The part of the distribution system containing low voltage equipments.

Security	The probability for a protection of not having an unwanted operation under given conditions for a given time interval.
Single failure criterion	Criterion applied to a system such that it is able to perform its task in the presence of any single failure
S_n	Nominal power
SvK	Svenska Kraftnät, <i>TSO</i> in Sweden
TSO	Transmission system operator
ω	Mechanical speed
ω_s	Synchronous speed

Chapter 1

Introduction

In the last few years a trend in power engineering has been towards distributed generation. This goes hand in hand with the general development in the society, where small scale solutions and nearness have been considered as answers to many problems.

A frequent metaphor used to describe the old industrial society was the steam locomotive which radiated the image of centralized power. The sociopolitical and economic development was driven from centralized institutions (preferable in the capital cities). The resemblance with the centralized power stations is striking.

To describe today's post modern society the metaphor is no longer the locomotive but the network, where the individual node interacts with its neighbors. The network has no fixed border lines and no centralized easily identifiable power source. It connects the individual into a global context of relationships and interactions. The problems are global and general but they are formulated locally and the solutions should also be local. Also this metaphor fits well with the developments in the energy field. The problems occur where local meets global, regardless if the society or the power system is considered.

1.1 Motivation

This thesis deals with a particular problem that occurs at the interface between a distributed generation plant and the rest of the power system. The problem can be described as islanding detection in power systems. The problem has been investigated and discussed extensively in the last few years.

It is of great importance that the detection is done accurately and fast (as will be explained in the next chapter). Yet, a final answer to the problem seems to be lacking.

Island operation occurs if one or more distributed energy resources (DER) continues to energize a part of the grid after the connection to the rest of the system has been lost. An illustration is given in Figure 1.1.

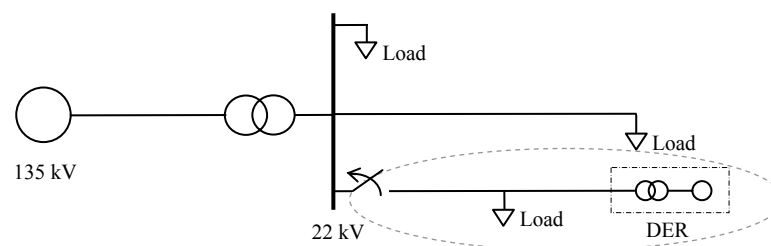

Figure 1.1 The lower 20 kV-feeder and the load are energized by the DER-unit. This is said to be a power system island.

Island operation can be either intentional or unintentional. In the first case the islanding has been planned in advance and the system and equipment has been designed to cope with the situation. The DER is then well suited to control voltage and frequency in the islanded grid. Intentional islands often exist in industrial plants where the process has surplus energy that can be used to produce electricity. Examples are found in paper mills and sugar mills that often are capable of producing a large part of their electricity need internally. During thunderstorms or other adverse weather situations these plants can switch to internal production and isolate themselves from the surrounding grid. By doing so the risk of disturbances due to lightning strokes and other faults affecting the vulnerable process is limited.

Another example of intentional islanding is emergency backup power in hospitals. A modern hospital depends on electricity and a blackout can be devastating. It is not hard to imagine that consequences may be serious if the electric power is interrupted during an open-heart surgery. To ensure the power delivery most hospitals have emergency generators capable of providing power to all important parts of the hospital. Some critical parts may even have an uninterruptible power supply with battery storage.

Unintentional islanding is something else. The DER equipment may not at all be suited to control voltage and frequency. This means that the power

quality can not be guaranteed by the utility. The voltage and frequency can even get so out of range that installed custom equipment is destroyed.

Even if the DER can control voltage and frequency the dispatch center of the utility may not be able to supervise the plant. A consequence may be that personnel are sent out to work on potentially dangerous live feeders, believed to be safe.

The thesis work is motivated by three actual cases:

Jutland case

In Jutland in eastern Denmark on 18 February 1996 a two-phase short-circuit occurred on a 150 kV line with a following voltage dip as consequence. Distributed production units, with a production of more than 300 MW, in a very large area were tripped from the system since the situation incorrectly was treated as an island state by the protection system. If it had not been possible to import power from surrounding countries a deficit of power possibly followed by a voltage collapse could have occurred. To avoid these kinds of situations in the future a more reliable detection method is needed.



Figure 1.2 Eltra service area. 47 local CHP units, larger than 2 MW each, with a production of 347 MW were tripped. It is unknown how many units smaller than 2 MW that were tipped.

Landskrona case

During his work as a consultant in power systems the author had the opportunity to follow a case where a group of wind power generators were severely damaged. During digging work an excavator hit an underground cable. A breaker failed to operate and the power plants were isolated with a minor load. The wind turbine generators continued to feed the arc at the faulted cable and the load for a while. The island ceased to be energized when equipments in one generator plant after the other broke down. The situation would properly have ended differently if the plants would have been equipped with proper islanding detection devices.

Ätran case

At the beginning of his employment as a PhD-student the author was invited to take part in an islanding experiment performed by the south Swedish utility Sydkraft¹. A small 50 kV-system with hydro power production units and matching load was disconnected from the strong grid. The purpose was to verify that a new turbine governor could keep the frequency within acceptable limits. The experiment was successful except for that a group of wind power generators were tripped from the small system by the islanding detection device. The device had detected that an island situation was present. Since the islanding was intentional the tripping was undesirable.

1.2 Objectives

The objective of this thesis is to investigate how different islanding detection methods fulfill their tasks. An islanding detection device has to be reliable. To investigate reliability the thesis explores both dependability and security of different methods at various contingencies in the grid. By dependability the degree of certainty that the relay protection device will operate when it is expected to operate is understood, (IEEE 2000). The second case above serves as a good example of lack of dependability, since the relays did not operate correctly.

¹ In September 2005 Sydkraft AB changed names to E.ON Sverige AB. Wherever Sydkraft AB is mentioned in the thesis it refers to E.ON Sverige AB.

Security is the aspect of reliability that describes the ability of the relay protection system not to operate incorrectly, (IEEE 2000). In the first case above many power plants were incorrectly disconnected, hence it can serve as an example of lack of security.

To focus the thesis the studied power system islands have been energized with induction generators. This is a kind of islanded system that by many has been considered, if not impossible, at least very unlikely to exist. It is however both theoretically and practically possible, see for instance (Tang and Zavadil 1993). The reason for this choice is simply that many wind power plants, including these in the examples above, are equipped with induction generators. Another example of induction generators is Nysted Offshore Wind Farm in Denmark. Nysted is to date the largest offshore wind farm in the world with 72 turbines of 2.3 MW each (in all 165 MW).

1.3 Outline of the thesis

Chapter 2 starts with a general overview of distributed energy resources. Different parts of the concept are described and the notation *islanding detection* is defined.

In Chapter 3 parts of grid codes from four different nations are described and compared. The central point is in the parts that affects islanding detection.

Different methods for islanding detection are described and commented on in Chapter 4. The methods are divided into three subgroups; *passive* and *active* methods and methods using *communication*.

Chapter 5 describes the model used in the simulation software. All major parts of the model are described and data are presented in tables. In Chapter 6 the model is used in simulations of different islanding formations and contingencies. The results are presented in diagrams.

The islanding detection algorithms presented earlier are tested on the simulation results in Chapter 7 to Chapter 10. The outcome is presented and discussed in Chapter 11.

Conclusions of the study are summarized in Chapter 12 followed by some ideas on future work.

1.4 Contributions

This thesis contributes with comparison of different islanding detection methods during various contingencies in a power system.

The negative influence of different grid codes on the possibility to detect islanding with presently used algorithms is commented on.

A possible method to detect islanding involving induction generators is suggested. The method needs further developments but can be useful in the future.

Chapter 2

Distributed energy resources

This chapter contains an overview of distributed energy resources and the technique behind it. Different energy sources are discussed as well as commonly used energy converters. The system impact of distributed energy resources and the phenomenon *islanding* are dealt with. Finally the notation *islanding detection* is defined.

2.1 Distributed energy resources

In the thesis distributed energy resources, or DER, will be used as a general term, including distributed generation and energy storages. There are many different notations describing the same thing. In the US and in parts of the world influenced by US *distributed energy resources*, *distributed generation* and *dispersed generation* seem to be dominating notations. In British English *embedded generation* is more frequently used. In this thesis the notation DER will be used.

By DER probably most power engineers understand a power source connected directly to the primary or secondary distribution system. A common opinion is also that there is some limitation in size (which evidently is given from the connection to the distribution system).

One definition is discussed in (Ackermann et al., 2001). The IEEE Standard 1547 proposes another one, (IEEE 2003a).

DER is not a new concept. It has existed for a long time; as a matter of fact it is as old as power system itself. In the early days of electrification it was the natural way to connect power sources to the grid. When the power systems developed, neighboring systems where interconnected with transmission systems. One reason for this was to increase the availability

of the system. To further increase the availability it became accepted to connect larger power plants to the transmission system.

In the last decade it has again become common to connect power plants to the distribution system. The main reason for this is probably that the size of many new plants makes the distribution grid the natural connection choice. Single wind power plants or groups of a few plants have been installed in many places on the countryside remote from subtransmission grids. Therefore it has been an economically viable alternative. It is only when it comes to larger wind farms that it is justifiable to connect on higher voltage levels.

2.2 Energy sources

Almost all of the DER-units installed lately are claimed to be environmental friendly. It can always be discussed which prime movers that really fulfill that criterion. That discussion is however out of the scope of this thesis. The most common energy sources and their benefits and drawbacks are mentioned below.

Wind power

The number of wind power units installed in power systems around the world has grown significantly in the last two decades. The trend today is to construct large wind power farms offshore. Many of the installed plants are, however, small farms or individual plants on land connected to the distribution systems. In Europe a few countries, with economic and politic prerequisites, distinguish themselves from the rest; Spain, Holland, Germany and Denmark. In western Denmark the capacity of installed wind power has developed as presented in Figure 2.1. The present figure of 2400 MW shall be compared with peak load of 3600 MW in the same area, (Eltra 2000).

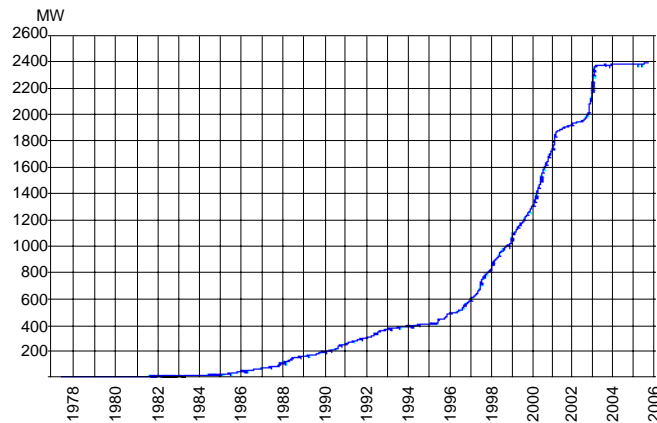

Figure 2.1 Wind power development in the Eltra service area. The maximum load in the same area is approximately 3600 MW. Source: www.eltra.dk

The energy source in wind power plants is the sun and wind power can therefore be claimed to be environmental friendly. It is argued that the environmental impact of wind power is how the towers affect the view of the landscape. If the sun is low on the skyline the turning turbine can also cause optic flicker phenomenon that can be annoying. Tower acoustic noise is another source of irritation.

CHP

Combined heat and power plants (CHP) produce both heat (approximately 60 %) and electricity (some 30 %), which gives them a rather high efficiency. CHP are installed in areas where there is a need for heat.

The fuel can be fossil, which gives rise to carbon dioxide. It has therefore been questioned how environmental friendly CHP are. The high efficiency has been used as an argument against this. CHP can also be run on biofuel.

Hydropower

The number of new installed distributed hydropower plants is not high in the Western Europe systems. The investment costs are very high and the environmental impact is considered to be high. In Sweden a few old dams that have not been used for long times have however been restored and reinvestment programs exist.

Photovoltaic

Photovoltaic converts light into electrical power. According to (Borbely, A.-M. and Kreider, J. F. 2001) photovoltaic systems can produce outputs from microwatts to megawatts.

The International Energy Agency, IEA, has a database of installed grid connected photovoltaic systems from around the world, (International Energy Agency 2005). The database lists examples of installations rated from a few hundred watts to more than 2 MW.

In Sweden there are only a few photovoltaic plants connected to the grid. Statistics from these plants can be found at (Solceller i byggandet 2005). The sum of the installed peak power is approximately 200 kW. Last year the production was 114000 kWh.

2.3 Energy storage

An asset believed to be used more frequently in the future is energy storage. The benefit is the possibility to store energy that can be used during peak hours. By doing so the system can be designed for less than peak power and the influence of bottlenecks can be reduced.

There are a few ways to store energy. It is difficult to store AC current. It is comparatively easy to store energy in hydroelectric dams. Norway can store close to 70 TWh, which is more than 50% of the annual consumption of electric energy.

In battery storage the energy is stored chemically in batteries. Kinetic energy can be stored in flywheels and potential energy in pressured air.

2.4 Energy converters

The generators in the power plants are responsible for the transformation of mechanical energy to electrical energy. There are mainly two kinds of generators connected to the grid: synchronous generators and induction (or asynchronous) generators. Besides these generators there are also power electronic converters, PEC, which can feed electrical energy to the grid. The kind of generator or PEC installed decides how the DER affects the grid during normal operation and disturbances.

Synchronous generators

Synchronous generators are the kind of generators that are used in large power plants around the world. The reason is that they can control the frequency and voltage level in the grid. If more power from the turbine is fed to the synchronous generator the grid frequency is increased and vice versa. The voltage can be affected by changing the magnetization current in the generator. This affects the reactive output and hence the voltage level.

In small power plants synchronous generators are used if they are intended as stand alone units operated without connection to the grid.

During short-circuits a synchronous generator contributes with large fault currents for a relatively long time. Fault currents four to five times the rated current is normal, (Kundur, P. 1994).

Induction generators

Induction generators have historically been used in small power plants. They are cheap in investment and need relatively little maintenance work. The drawback is that they cannot control voltage level in the grid they are connected to. They also need reactive power from the grid (or from shunt capacitances) to the magnetization.

An induction generator only participates with fault current initially. When the terminal voltage drops during a short-circuit, the ability of the machine to maintain magnetization decreases, which reduces the fault current.

Power electronic converters

Power electronic converters can control both active and reactive power. The short-circuit current magnitude from a PEC is not considerably larger than the rated current; a typically value mentioned is 115 %. This is due to the low ability of semiconductors to withstand overcurrents. The time a PEC continues to energize a fault depends on the algorithms controlling the transistors.

2.5 Power system impact

As mentioned earlier the kind of energy converter in a DER-plant determines how the grid is affected during normal operation and disturbances.

During normal operation a synchronous generator and a PEC can participate in the voltage regulation. An induction generator can not contribute to the voltage regulation. On the contrary the reactive consumption of an induction generator can counteract the voltage stability.

Depending on the kind of energy converter installed a DER-plant can affect the fault currents in a system. If a DER-unit with a synchronous generator is installed in a long feeder the fault current from the substation may decrease significantly. This can affect the sensitivity of the overcurrent relay protections negatively, since they have to detect faults both with and without DER-production. See Figure 2.2.

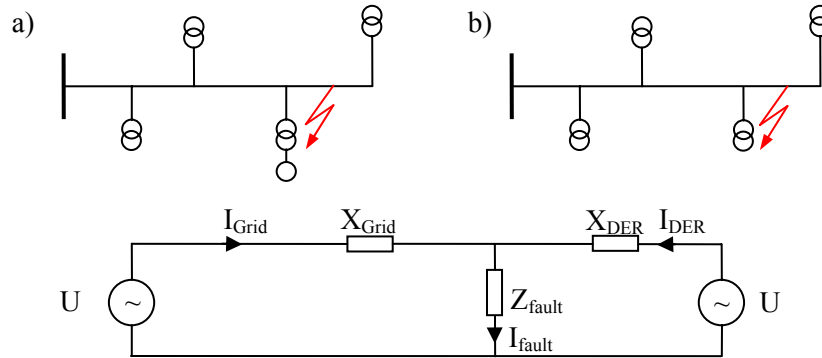

Figure 2.2 Fault current from the feeding substation (I_{Grid}) and from the DER-plant (I_{DER}).

Equation 2.1 gives the current from the feeding substation when the DER-plant contributes to the fault current.

$$I_{Grid} = \frac{U}{X_{Grid} + Z_{fault} + \frac{X_{Grid} \cdot Z_{fault}}{X_{DER}}} \quad (2.1)$$

Equation 2.2 gives the fault current without any contribution from the DER-plant.

$$I_{Grid} = \frac{U}{X_{Grid} + Z_{fault}} \quad (2.2)$$

A traditional distribution system is designed for a power flow from the substation to the customers. This means that the voltage drops over the feeder, see Figure 2.3 a). The distribution transformers connected to the feeder have off-load tap changers set to compensate for this drop. With a production source at the end of the feeder the power flow can be reversed during certain situations (low load and high production). This means that the voltage drop is changed, see Figure 2.3 b). Consequently, the customers may experience periods with extreme high voltages.

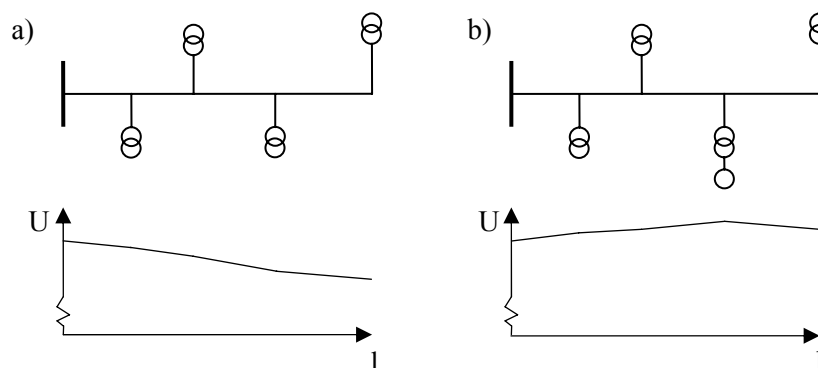

Figure 2.3 Voltage profile over a feeder without (a) and with (b) a DER-plant.

The most severe impact of DER to the system is properly nuisance tripping of large amounts of DER-plants. One example of this was the Jutland case described on page 3. The consequences of such an event could propagate throughout the system. Nuisance tripping of DER-plants has relatively recently been considered as a problem to the power system. In the past it was required in many countries to disconnect the DER-plants at an early stage of a disturbance. The reason was to get a less complex system to control.

2.6 Islanding

According to (IEEE 2000) an island is “That part of a power system consisting of one or more power sources and load that is, for some period of time, separated from the rest of the system.” In this thesis islanding refers to one or several DER-units forming an island. The load can consist of either an industrial plant or consumer facilities in a distribution grid.

As mentioned in Chapter 1 islanding can be either intentional or unintentional. If an island has been formed intentionally or not influences the

behavior of the islanded system. Installed frequency- and voltage regulators facilitate intentional island operation. Furthermore, the intentional islanding is preferably done with a minimal load flow to or from the main grid. Unintended islanding during a heavy load flow to or from the main grid necessarily causes an unbalance in production and load.

If there is a surplus of active power in the island energy is stored in the rotating masses. The speed of the generators will increase and the frequency rises. In a PEC-unit the extra energy is stored in the DC-link, which leads to an increase of the DC-link voltage. Lack of active power in the island would obviously lead to the opposite.

Reactive power unbalance affects the voltage level in the island. An excess of reactive power has the same influence as a shunt capacitor; the voltage increases. A shortage of reactive power naturally causes the voltage level to decrease.

An effect of large power unbalance in a newly formed island can be serious; such an island may not survive very long. On the other hand an island with perfect production balance can very well survive for a long time, even if there are no voltage or frequency regulators.

2.7 Protection systems

As any electric plant connected to the grid, DER-units have to be equipped with protection system. The purpose of such protection is twofold. One task is to detect fault currents fed from the grid to the plant and initiate tripping. The other task is to protect the surrounding grid from fault currents originating from the DER-unit.

The latter task can be fulfilled with overcurrent- and undervoltage-protection that protect the grid during short-circuits.

To protect the DER-unit from hazardous situations overcurrent relays can trip the main breaker at short-circuits within the plant. Over- and undervoltage and over- and underfrequency relays are installed to protect the DER-plant at abnormal grid situations. They must not be set to act against the appropriate grid code, which is further discussed in Chapter 3.

Islanding detection relays has the task to detect islanding and initiate action in order to protect the grid from ending up in an unintended island.

2.8 Islanding detection

This thesis is about islanding detection so it is motivated to carefully define the notation. *Loss of mains protection* (LOM), *loss of grid protection*, *anti islanding protection* and *islanding protection* are synonyms used around the world.

Throughout this work the expression *islanding detection* has been used. There are mainly two reasons for this. Firstly detection is more neutral than protection. It is not always necessary to protect against islanding. Sometimes it may be enough to be aware of the state, hence the word detection. Secondly the “ing”-part in *islanding* focuses on the change of states. This refers to detection in the very moment when the island is formed.

Why islanding detection?

The power systems are complex and not always easy to intuitively understand. They are highly automated and spread over nations and continents. Contingencies and faults occur regularly and many of these events are cleared automatically without human intervention. The utilities are responsible for the safety of the power system. Electricity can be dangerous to both humans and animals and it can also be harmful to equipment connected to the grid. A case where shunt capacitors were damaged is described in (Tang and Zavadil 1993).

If a part of the power system forms an uncontrolled island there is a risk that personnel sent out for maintenance work in the islanded system get in contact with the live parts of the equipment. This can cause severe injuries and death. Hence it is very important to detect and shut down unintended electric islands.

Many distribution feeders have protection systems with automatic reclosing equipment. This is common practice when the feeders are constructed with overhead lines where the fault is likely to disappear after a short interruption. From historical data it has been shown that permanent faults only occurs in 10 to 15 % of the feeder outages (IEEE 2003b). Automatic reclosing increases the availability of the power system since the interruption time is minimized.

If, however, the automatic reclosing occurs against an energized feeder with a DER-plant it is not unlikely that the grid voltage and the energy

converter at the plant are out of phase. This can cause damages to the installed equipment.

Another drawback with automatic reclosing against an energized feeder is that a capacitive switching transient can cause a severe overvoltage. In a lightly damped system the overvoltage can reach three times the nominal voltage or twice the nominal voltage in a more damped system, (Greenwood, A. 1971). The capacitances involved in the transients are found in cables and shunt capacitances in the islanded system.

Typical values of autoreclose open times are listed in Table 2.1.

System voltage [kV]	Autoreclose open time [s]
130	< 1
50	< 3
20	< 30

Table 2.1 Typical autoreclose open times in Sweden.

Requirements on islanding detection

To avoid overvoltages and damages from inrush currents it is important to disconnect DER-units before automatic reclosing is adopted. Keep in mind that it is almost always possible to change the autoreclose open time to adapt to the islanding detection device.

An islanding detection system has to discriminate between islanding and other events in the power system. The detection system has to be reliable, which is measured by the terms dependability and security.

The requirements on islanding detection devices are summarized in the following list.

- Dependable – An islanding detection device must detect all islanding events.
- Secure – An islanding detection device must not respond to events or disturbances in the grid other than islanding.
- Fast – The detection device has to respond within the time given by Table 2.1.

Chapter 3

Grid codes

To connect a DER-unit to the system certain minimum requirements have to be fulfilled. These requirements are usually specified by the transmission system operator, TSO.

Two important areas of the requirements are how to ride-through¹ a voltage disturbance, at for instance short-circuits, and how the power plant shall contribute to the power balance at frequency excursion situations.

There are also standards and other regulations that state how the distributed generator shall behave at different disturbances.

In the following some of the grid codes of different TSOs in Europe are presented from an islanding detection point of view.

3.1 AMP

AMP, *Anslutning av Mindre Produktionsanläggningar till elnätet* (Connection of small production plants to the grid), is published by *Svensk Energi*, the association of Swedish utilities. AMP has become a de facto standard on how to connect small (less than 1.5 MW) power plants to the Swedish grid, (Svensk Energi 2002).

AMP states that measures have to be taken to assure that island operation cannot occur. AMP suggests relay protection devices with settings according to Table 3.1.

¹ In this thesis ride-through capability refers to the ability of equipment to withstand momentary voltage interruptions or sags, (IEEE 2000).

Relay	Trip level	Operating time
U<<	0.8 p.u.	0.2 s
U<	0.9 p.u.	60 s
U>	1.06 p.u.	60 s
f<	48 Hz	0.5 s
f>	51 Hz	0.5 s

Table 3.1 Relay settings suggested by AMP.

AMP argues that if it takes too long time to detect an island situation using these simple means more sophisticated detection methods are necessary. Phase shift and Rate of change of frequency (ROCOF) relays are mentioned as examples, see further Chapter 4.

3.2 Svenska Kraftnät

Svenska Kraftnät, the national TSO in Sweden, is currently revising their regulation document for connection of production plants. The description here relates to a preliminary version, (Svenska Kraftnät 2005).

Svenska Kraftnät discriminates between large, medium and small-sized production plants, see Table 3.2. This thesis focuses on medium- and small sized power plants, since distributed generation plants are most likely to be found within these groups.

Small and medium sized power plants have to be capable to ride-through voltage disturbances in the meshed transmission grid such as the one presented in Figure 3.1.

Size	Hydro power (MW)	CHP (MW)	Gas turbine (MW)	Group of wind power generators (MW)	Single wind power generator (MW)
Large	>50	>100	>100	>100	-
Medium	25–50	25–100	25–100	25–100	-
Small	1.5–25	1.5–25	1.5–25	1.5–25	>1.5

Table 3.2 Classification of power plants according to Svenska Kraftnät.

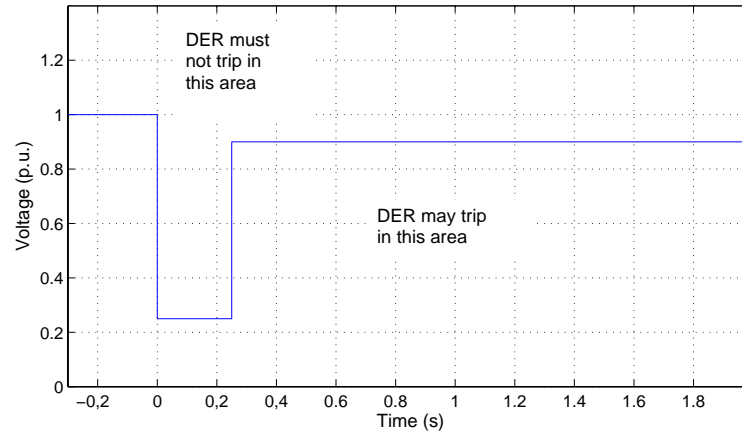

Figure 3.1 The ride-through demand of Svenska Kraftnät on small and medium sized power plants at voltage disturbances.

Svenska Kraftnät has three different dimensioning requirements on how the production plants have to behave at frequency and voltage excursions. For small sized plants the requirements are quite modest, see Figure 3.2. The time in the different boxes refers to the least time the connected power plant has to deliver power to the grid under the given conditions.

For medium and large production sites the requirements depend on the kind of production source. Hydro power, gas turbines and groups of wind power generators have to be able to withstand the disturbances visualized in Figure 3.3.

For thermal power plants the limitations of the turbines are important and the requirements on frequency excursions have been adjusted accordingly, see Figure 3.4.

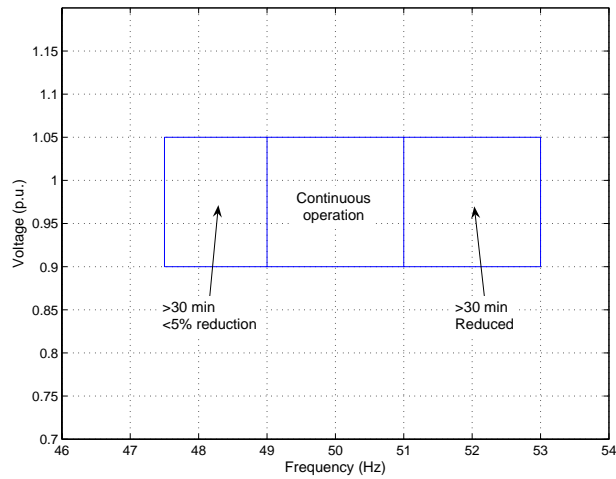

Figure 3.2 Requirements of Svenska Kraftnät on small-sized power plants.

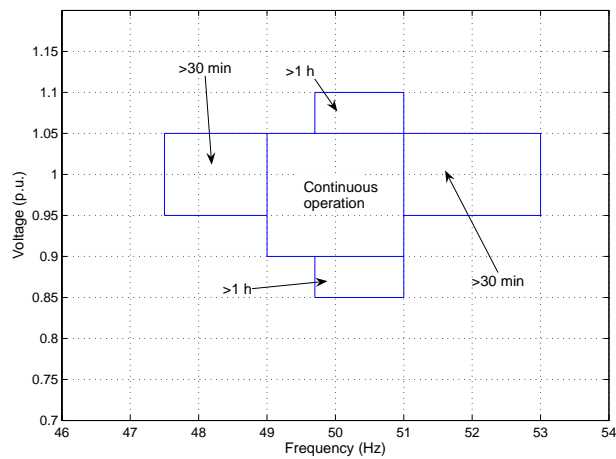

Figure 3.3 Requirements of Svenska Kraftnät on large and medium-sized hydro power, gas turbines and wind power groups.

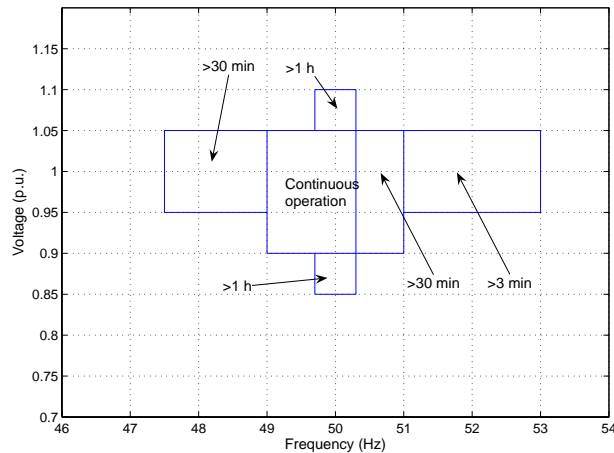

Figure 3.4 Requirements of Svenska Kraftnät on large and medium-sized thermal power plants.

3.3 Eltra

Eltra is the TSO in western Denmark¹. In the past decades a large number of wind power plants have been installed in the Eltra grid. This has come to influence the behavior of the system.

Eltra has, together with Elkraft System (TSO in eastern Denmark), issued connection conditions for wind power plants in the Danish systems. The conditions are issued in two versions, one for plants connected to voltages above 100 kV, (Elkraft System and Eltra 2004a) and another for plants connected to voltages less than 100 kV, (Elkraft System and Eltra 2004b).

The ride-through requirements at voltage disturbances in the grid are illustrated in Figure 3.5. Unless the voltage drops below the lower border line the generator must not be disconnected from the grid. Eltra also has a requirement to trip the generator if the voltage gets too high for a time period. This is indicated by the upper line in the figure.

¹ During the autumn in 2005 Eltra was merged with Elkraft System, Elkraft Transmission and Gasta. The new company name is Energinet.dk. Energinet.dk constitutes the new TSO of Denmark.

From Figure 3.6 the dimensioning requirements can be read. The connected wind power plants must not cease to produce power to the grid as long as the time does not exceed the values indicated at the different areas in the figure.

Eltra has also given settings for protective devices where the plant must be tripped. The purpose of this is to facilitate a grid restoration after a major disturbance. These settings are presented in Table 3.3. The design requirements in Figure 3.6 are more restrictive than the settings given in Table 3.3. This is a precaution for future changes in the settings.

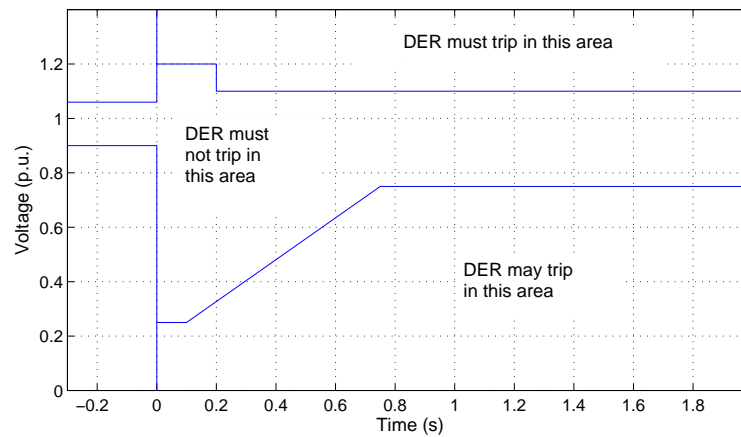

Figure 3.5 Ride-through requirements of Eltra on wind power generators connected to voltages less than 100 kV.

	Setting value		Delay	
Undervoltage	0.9	p.u.	10...60	s
Overvoltage 1	1.06	p.u.	60	s
Overvoltage 2	1.1	p.u.	200	ms
Overfrequency	51*	Hz	200	ms
Underfrequency	47	Hz	200	ms

*If the wind power plant contributes to frequency control other values are valid.

Table 3.3 Disconnection criteria in the grid of Eltra.

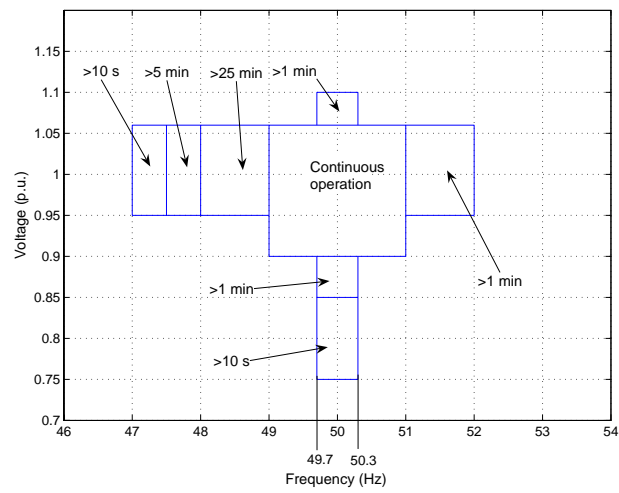

Figure 3.6 Dimensioning voltages and frequencies of Eltra.

3.4 E.ON Netz GmbH

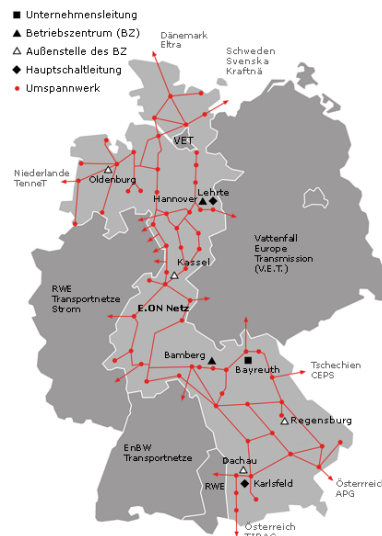

Figure 3.7 The control area of E.ON Netz GmbH.

E.ON Netz GmbH is a transmission system operator in part of Germany, as illustrated in Figure 3.7.

The connection requirements of the high and extra high voltage levels have been published in the Grid Code, (E.On Netz GmbH 2003). Distribution systems connected to the transmission system have to fulfill all conditions in the Grid Code. In practice this means that a generator connected far out in the distribution system also has to perform according to the Grid Code.

The Grid Code of E.ON does not discriminate between small and large power plants. Instead, E.ON has two different ride-through demands depending on how much short-circuit current the generator contributes to the grid. A generator contributing with more than twice as much short-circuit current as its rating for longer time than 150 ms must not trip from the grid if the voltage is above the line in Figure 3.8. If these conditions are not fulfilled Figure 3.9 is applicable.

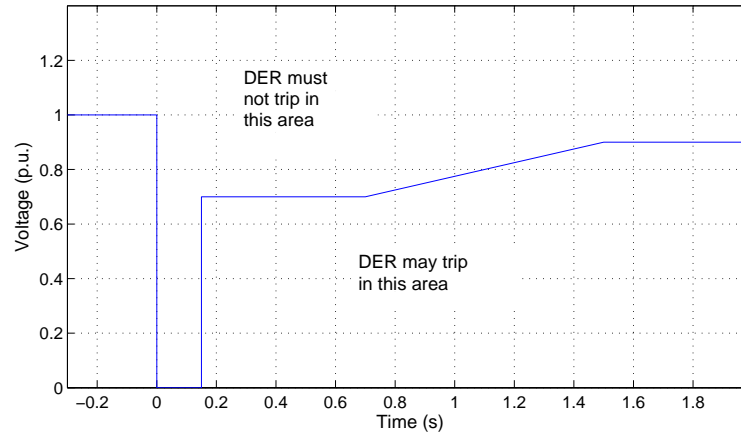

Figure 3.8 The ride-through demands of E.ON on generators contributing with a short-circuit current that is higher than twice the rated current for longer than 150 ms.

Active power output must be resumed immediately after fault clearance and increase with a gradient of at least 20% of the rated power per second. In the shaded area in Figure 3.9 the active power increase may be as low as 5% of the rated power per second.

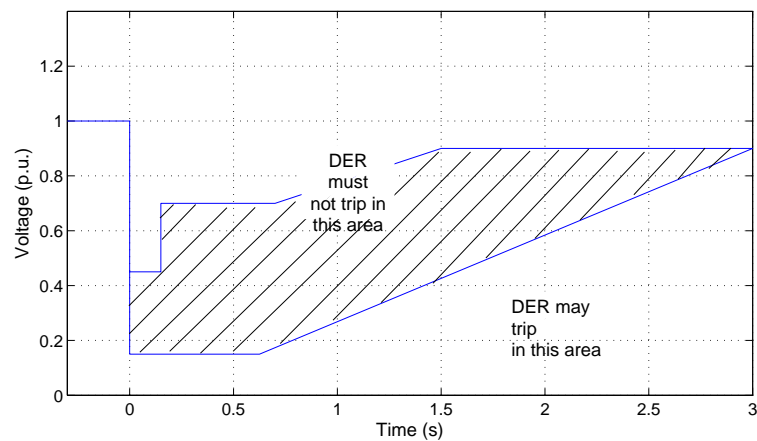

Figure 3.9 The ride-through demands of E.ON on generators contributing with a short-circuit current that is less than twice the rated current. The generator must not trip from the grid if the voltage does not drop below the lower line.

In Figure 3.10 are the dimensioning requirements of E.ON visualized. As long as the time indicated at the different areas in the figure not is exceeded the connected power plant must not be disconnected from the grid.

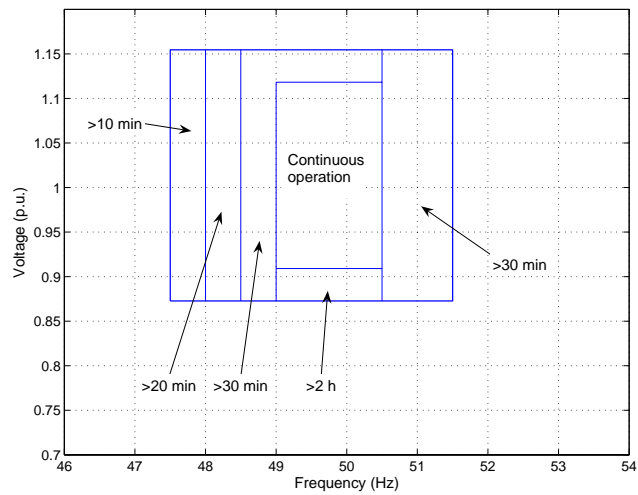

Figure 3.10 Dimensioning voltages and frequencies of E.ON at 110 kV level.

3.5 IEEE Standard 1547-2003

The IEEE Standard 1547 is applicable to DER-units with a rated power of less than 10 MVA and connected to the primary or secondary distribution system.

The IEEE Standard 1547-2003 states that an island shall be detected and de-energized within two seconds from the island formation. Four different detection options are mentioned as examples in the standard. These options are quoted below¹, (IEEE 2003a):

1. The DR aggregate capacity is less than one-third of the minimum load of the local Electric Power System, EPS.
2. The DR is certified to pass an applicable non-islanding test.
3. The DR installation contains reverse or minimum power flow protection, sensed between the Point of DR Connection and the PCC, which will disconnect or isolate the DR if power flow from Area EPS to the local EPS reverses or falls below a set threshold.
4. The DR contains other non-islanding means, such as a) forced frequency or voltage shifting, b) transfer trip, or c) governor and excitation controls that maintain constant power and constant power factor.

¹ The expression DR – Distributed Resource – is used in the IEEE Standard 1547.

3.6 Summary

There are many similarities between the grid codes described in this chapter. They all have rules on ride-through capabilities of installed power plants and they all define frequencies and voltage levels within which the plants have to be able to operate.

E.ON and Eltra have rules that do not discriminate between the sizes of the power plants. By this they have foreseen a situation with a large part of the production origin from small plants. In such a situation the system impact of the small plants cannot be disregarded and the new requirements include also the small plants.

Svenska Kraftnät has discriminated between three different groups. The toughest demands are on the large hydropower plants. The requirements on small plants (1.5 – 25 MW) are modest.

Chapter 4

Methods for islanding detection

There are quite a few different methods used to detect islanding. All methods have benefits and drawbacks. The methods have traditionally been divided into two subgroups; *passive* and *active* methods. In this thesis a third subgroup has been added; methods relying on *communication* for islanding detection. These methods have earlier been listed under the group of active methods. Since they are based on different principles they deserve a special subgroup.

4.1 Passive methods

Passive methods use locally available quantities such as voltage or frequency. The quantities are derived from the high voltage level using voltage and current transformers, which feed the detecting device.

The passive methods do not affect the waveform of the high voltage. This is beneficial since it does not give rise to power quality issues such as voltage dips.

Another benefit is that communication is not required to build up the detection system. Communication has traditionally been considered as expensive and vulnerable.

Some common passive methods are described in the following sections.

Voltage

Voltage relays measure the voltage magnitude at the DER-unit and trips the generator if the voltage has been abnormal during a certain time. The relay can respond to both under- and over-voltage situations. In principle

the method relies on that an unbalance between reactive production and consumption occurs after the loss of mains. This unbalance leads to a change in voltage level, which can be measured locally.

The time delay has to be coordinated with the possible fault duration on higher levels of the system, since a short-circuit there can depress the voltage at the distributed power plant.

It is important that the voltage relays do not violate the ride-through demands of the applicable grid code. Hence the settings have to be chosen such that the level and time delay do not trip the generating unit unless the voltage has excused outside the limitations.

Frequency

During steady-state the frequency is the same in the entire system. The speed of a synchronous generator is proportional to the average frequency. With the slip taken into consideration the same is valid for an induction machine. For slow changes in the balance between production and load Equation 4.1 gives the speed change of the machines.

$$\frac{d(n/n_s)}{dt} = \frac{P_{production} - P_{load}}{2 \cdot H \cdot S_{nom}} \quad (4.1)$$

where n is the mechanical speed
 n_s is the synchronous speed

The relationship between speed and frequency changes during transients, such as switching and faults. For a synchronous machine the change of currents through the machine reactance causes a vector shift, $\Delta\theta$. The vector is changed in the short time frame of the transient, Δt . A frequency change according to Equation 4.2 follows.

$$\frac{\Delta\theta}{\Delta t} = \Delta f \quad (4.2)$$

where $\Delta\theta$ is the vector shift of the terminal voltage

In an induction machine the relationship between speed and frequency can diverge even more at transients. Due to the slip there is no fix relation between the speed of the turbine and the grid frequency. Beside the vector shift caused by the current change over the machine reactance the slip changes due to the altered power flow during the disturbance.

During faults the grid frequency measured on buses in the network is not exactly equivalent to speed.

A frequency relay takes its decision based on the frequency of the voltage at the DER-plant. If the frequency rises above (overfrequency) or drops below (underfrequency) predetermined limits for a certain time, then the plant is tripped from the grid.

The underfrequency situation can occur if the connection to the strong grid is lost at a situation where the local load exceeds the production of the distributed generator. The frequency is then slowed down by the excessive load.

Another contingency that can cause underfrequency is loss of a bulk power production unit.

Overfrequency situations can arise if there is a production surplus at the time when the islanding begins.

Rate of change of frequency

Rate of change of frequency (ROCOF) implies that such a relay uses the time derivative of the frequency to detect islanding. The frequency derivative of a synchronous machine was discussed above. At islanding the difference between production and load power is outbalanced with the kinetic energy stored in the turbine and rotor of the machine. This causes a change in the speed which also affects the frequency.

From Equation (4.1) it is clear that the difference between load and production affects the speed derivative. If the production and load are in perfect balance just after a switch to an island operation has occurred the speed derivative will be small and difficult to detect. The grid frequency will not be affected significantly. Hence the ROCOF-relay will not be able to detect the islanding. (Jenkins, N., Allan, R., Crossley, P., Kirschen, D. and Strbac, G. 2000) and (Guillot et al. 2001).

Vector shift

In Figure 4.1 the generator and the main grid share the work to provide power to the load. The voltage drop over the generator impedance, ΔV , is determined by the current from the generator.

When an island situation arises the current from the main grid is lost and the generator takes the whole burden. The increased current causes ΔV to

change, which in its turn causes the load angle to increase, as illustrated in Figure 4.2.

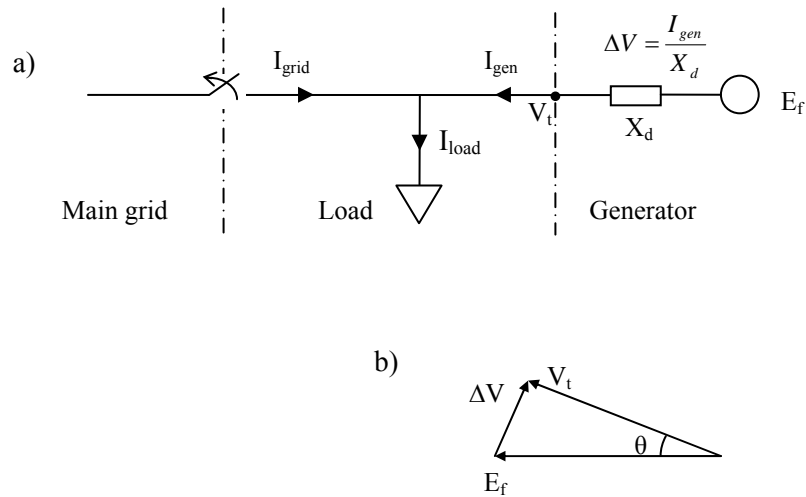

Figure 4.1 Vector shift relay. Load angle, θ , before islanding.

The increased load angle corresponds to a time lagged zero crossing of the voltage which is visualized in Figure 4.3. The vector shift relay utilizes this by comparing the cycle times. If the time suddenly changes it corresponds to a change in load angle. In a 50 Hz system the nominal period time is 20 ms. For example, if one period time of 20.5 ms is suddenly measured this means that the load angle has changed 9° and some action may be necessary.

It is important to point out that also other grid events than islanding causes the load angle to change. Such events could be short-circuits or sudden changes in grid impedances. To discriminate from short-circuits and generator startup an under-voltage relay is usually used to block the vector shift relay. (Freitas et al. 2005a) and (Jenkins, N. et al. 2000).

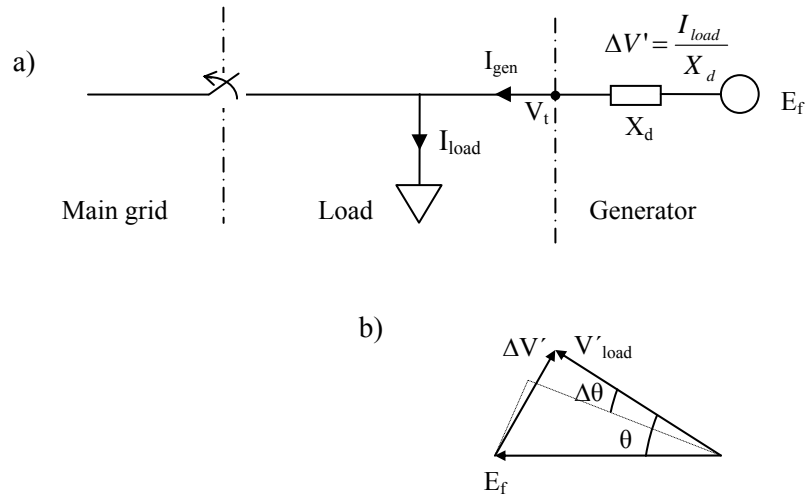

Figure 4.2 Vector shift relay. Load angle, θ , after islanding.

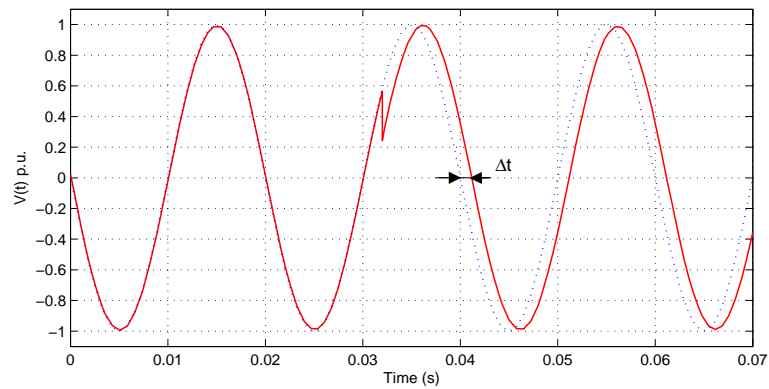

Figure 4.3 The change in load angle corresponds to a time delay.

The vector shift relay is also denoted *vector surge relay* and *phase displacement monitor*.

Other methods

Beside the methods described above there are a few other passive methods that not will be investigated further in this thesis. A few of them will, however, be described briefly in the following.

Power fluctuation method

The power fluctuation method has been described by (Redfern et al. 1997). The algorithm calculates the rate of change of power from the generator. This rate of change is then integrated over a few cycles and if the integrated value exceeds the trip setting an island has been detected.

Rate of change of voltage and changes in power factor

In (Salman et al. 2001) a method is described where the rate of change of voltage is combined with changes in power factor. The rate of change of voltage can not by itself distinguish between islanding and other grid events. Neither can the changes in power factor. But the combination is claimed to be able to detect islanding.

4.2 Active methods

Active islanding detection methods either try to manipulate the voltage or the frequency at the connection point or the manipulation is a result of measurements used by the method.

Beside this Section, active methods will not be dealt with further in this thesis. The active methods have in general a better reliability than the passive methods. However, the price is a negative influence on the power quality.

Forced frequency shifting

When this method is implemented the energy converter tries to move the grid frequency away from the nominal value. If it succeeds it is very likely to be feeding an islanded part of the power system. An application for photovoltaic systems using this method is described in (Ropp et al. 1999).

Reactive power fluctuation

This method is applicable to energy converters that can control the reactive output, i.e. synchronous generators and PEC:s. Small fluctuation signals are added to the automatic voltage regulator output. This leads to fluctuation of the voltage close to the DER-plant. If the DER-plant is feeding an island this will in its turn lead to a load fluctuation and consequently a frequency fluctuation that can be detected with ordinary methods. This method is described in (Funabashi et al. 2003), where a method denoted *Reactive power compensation* also is described. In this case the fluctuation signal is used at a reactive power compensator, which makes the method work with induction generators.

Fault level monitor

Fault level monitors rely on the fact that most power system islands have less short-circuit power than the main grid. By monitoring the change the islanding can be detected.

In a patent application (Fox, B. and O Kane, P.J. 1998) a method superimposing a small high frequency signal onto the grid voltage is described. Changes in the system impedance can then be monitored with a receiver.

Another method is described in (Warin 1990). A shunt inductor is shortly connected across the grid voltage using a thyristor switch. The current and voltage are measured and the short-circuit power is calculated.

4.3 Methods using communication

Communication has been considered to be expensive. This is however changing when new communication channels can be utilized. Traditionally only utility owned wires and channels subscribed from public telephone companies have been considered. Today radio transmitting (FM or AM) and optic fibers can be added to the list. Internet with TCP/IP makes it possible to communicate the same information to a wide range of equipment. The interdependability between the communication channel and the power system must, however, be considered.

Phasor Measurement Units

The utilizing of PMU:s to detect islanding are described by (Ishibashi et al. 2004). The system consists of two units, one at the utility substation and the other at the DER-plant. At the substation voltage and angle are measured and time stamped before being sent to the receiver at the DER-plant. It can there easily be determined if the DER-plant is synchronized with the grid or not. The accurate time stamp makes the method independent of small time delays in the communication channel.

A way to make this method less vulnerable to loss of communication could be to implement a “digital synchronous generator” or a phase locked loop (PLL) in the relay. This could then keep track of the grid frequency for a while even with loss of communication.

COROCOF

Comparison of rate of change of frequency, COROCOF, compares frequency changes at two locations in the grid. At the substation the rate of change of frequency is measured and a block signal sent to the DER-plant if the value has exceeded a limit. At the DER-plant the rate of change of frequency is also measured. If no block signal has been received when a frequency change has been discovered the DER-plant is tripped. The method is described by (Bright 2001).

SCADA

The SCADA-system keeps track on the states of the circuit breakers in the grid. The information in the SCADA-system should therefore be enough to determine if a part of the system has been islanded, (Funabashi et al. 2003). The drawback is that this solution is rather slow, especially when the system is busy with many events from one or more disturbances. Data from a major disturbance are presented in Figure 4.4.

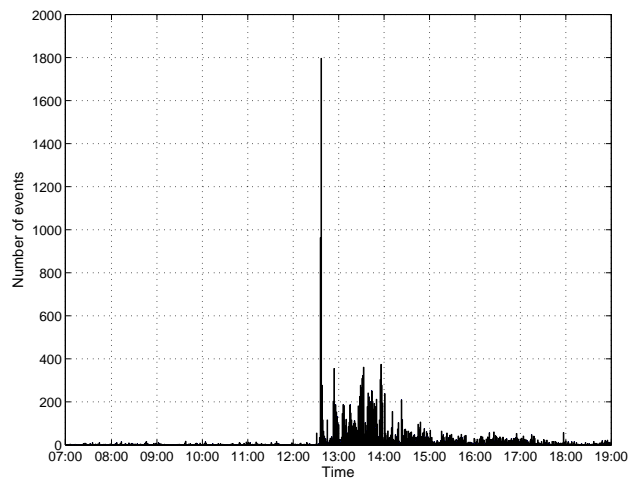

Figure 4.4 Number of reported events per minutes to the SCADA-system during the blackout on 23 September 2003 in south Sweden and eastern Denmark. During the 12 hours in the figure 22335 events were reported to the dispatch centre. By courtesy of E.ON Sverige AB.

Transfer tripping scheme

Transfer tripping scheme can be considered as a decentralized version of the SCADA-system described above. Logic circuits uses information of circuit breaker states to determine if a part of the grid has been islanded. The result is then transmitted to the DER-plant.

Chapter 5

Simulation model

In order to investigate the performance of the different methods during various contingencies a simulation model was implemented. It is important that the model reflects a real system in all vital parts. The behavior of the simulated system must be similar to what happens in a real situation. How this has been achieved is described in the following.

In this thesis the emphasis has been put on wind power turbines and induction generators. The reason for this is the ongoing extension of wind power.

5.1 System

In Figure 5.1 a single line diagram of the system in the simulation model is presented. From the left to the right the system consists of a strong 130 kV grid represented by a Thevenin equivalent, a 130 kV line, a transformer and a 20 kV distribution system. The distribution system has two fully represented feeders and loads and capacitances representing a number of other feeders. At the end of one feeder a distributed generation plant is connected.

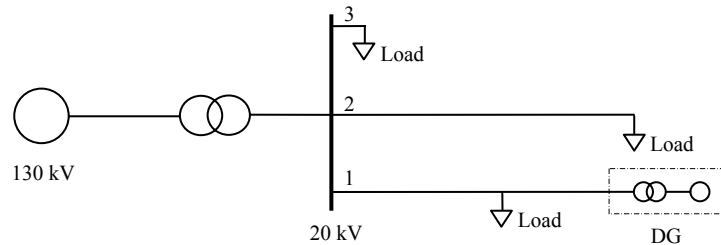

Figure 5.1 Single line diagram of the simulated system.

5.2 Strong grid

The Thevenin voltage is 135 kV with a frequency of 50 Hz. The Thevenin impedance is $0.43 + j3.04 \Omega$, which gives a short-circuit level of 6000 MVA and an X/R-ratio of 7. The 130 kV neutral point is solidly earthed.

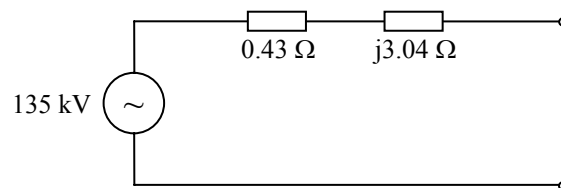

Figure 5.2 Thevenin equivalent of the strong grid. The corresponding short-circuit power is 6000 MVA.

In the simulation cases where records from real events have been used as inputs the Thevenin voltage amplitude and frequency have been varied accordingly.

5.3 Transformer

The transformer data is presented in Table 5.1.

Rated power	16	MVA
Ratio	130/22	kV
R_k	0.27	%
X_k	8	%

Magnetizing resistance	500	p.u.
Magnetizing reactance	500	p.u.

Table 5.1 Transformer data.

5.4 Lines

There are three different feeders on the 20 kV-level. Two of them are fully represented in the model. Data are listed in Table 5.2. The third feeder is only represented with a capacitance of $4.5 \mu\text{F}$, which corresponds to approximately 400 km overhead lines or 16 km underground cable.

The resistance and inductance of the 130 kV-line represents a short distance line (40 m), but the capacitance represents a larger system.

	Length km	R		L		C	
		Pos. seq. Ω/km	Zero. seq. Ω/km	Pos. seq. mH/km	Zero. seq. mH/km	Pos. seq. nF/km	Zero seq. nF/km
Feeder 1a	8	0.25	0.40	1.10	5.97	11.02	6.10
Feeder 1b	8	0.53	0.68	1.17	2.16	9.92	6.10
Feeder 2	20	0.53	0.68	1.17	6.05	10.00	6.10
130 kV	0.04	0.07	0.32	0.06	0.22	2881	2061

Table 5.2 Line data

5.5 Loads

The loads are represented by delta connected parallel resistances and inductances. This means that the reactive power varies with frequency and that active and reactive power absorbed by the load is proportional to the square of the voltage. The delta connection is justified by the fact that most distribution transformers (MV/LV) in north European systems are delta

connected in the primary (MV) side. A consequence of this is that the high voltage side will not be affected by unbalances in the low voltage side.

The sum of the load at nominal voltage and frequency is 1145 kW and 956 kvar.

5.6 Power plant

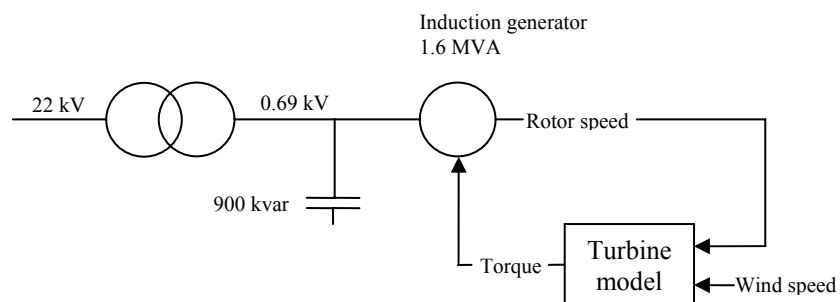

Figure 5.3 Distributed generation plant.

A single line diagram of the distributed generation plant can be seen in Figure 5.3. The voltage is transformed from the generator level at 690 V.

The squirrel cage induction generator has a nominal power of 1.65 MVA. Other important generator data are presented in Table 5.3.

Stator resistance	0.0037	p.u.
Stator inductance	0.0473	p.u.
Rotor resistance	0.015	p.u.
Rotor inductance	0.06	p.u.
Mutual inductance	3.5	p.u.
Rated frequency	50	Hz
Rated speed	1522	rpm
H (generator + turbine)	2.25	MWs/MVA

Table 5.3 Generator data

The electrical part of the generator is represented by a fourth-order state-space model.

A capacitor of 900 kvar is connected to compensate for the reactive power consumed by the generator.

The mechanical parts of the wind power generator and turbine are represented by a second-order system. The turbine is implemented as a look-up table, where wind and rotor speed are input parameters and the mechanical torque is calculated as depicted in Figure 5.4. The look-up table originates from a simulation model published by MathWorks, (Reid et al.).

During the simulations the wind speed was set to 10.65 m/s. This speed gives a good balance between production and load.

The model is equipped with neither mechanical protection devices nor stall regulations of the blades. In a real wind power plant the blades are stalled out of wind if the speed increases too much. It has been considered to be out of the scope of this work, which focuses on the electrical part of the power plant.

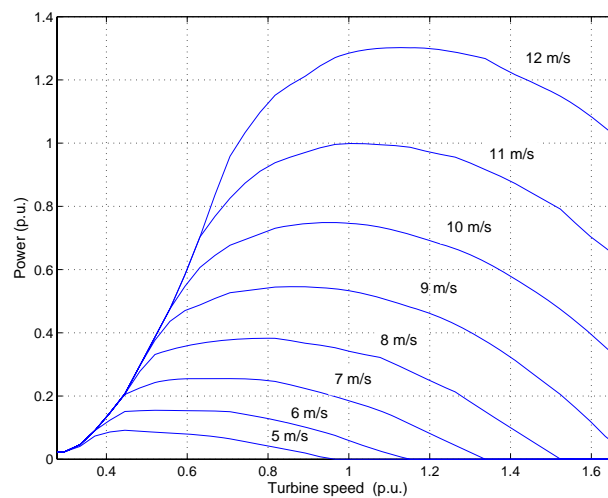

Figure 5.4 Wind turbine characteristic.

Chapter 6

Simulations

In this chapter a number of different cases are simulated. The cases have been chosen to represent a variety of different events and contingencies in a real power system. The cases have been set up to achieve island formations that are very hard to detect. Before the formation there is a very low power exchange to the grid and there are no preceding faults before the formation.

A brief summary follows below. The first group, islanding, is used to verify the dependability of the detection relays. Security of the relays is checked with the last two groups.

Islanding – Cases used to verify dependability

- Islanding with part of the 130 kV grid
- Islanding with 20 kV feeder
- Ätran islanding experiment⁺

Switching events – Events used to verify security

- Parallel connection of transformer
- Capacitor switching
- Loss of bulk power production⁺

Short-circuits – Contingencies used to verify security

- Short-circuit at the 130 kV level
- Short-circuit in the 20 kV transformer bay
- Short-circuit in adjacent feeder

⁺ Uses data from real events.

The islanding detection algorithms are applied to the resulting simulation data in the subsequent chapters.

The software used for the simulations was SimPowerSystems with Simulink and Matlab. Simulation of one contingency took approximately 20 hours.

6.1 Islanding with part of the 130 kV grid

An unnecessary relay operation can lead to this island formation. This island may also be formed if part of the feeding subtransmission grid is disconnected from the rest due to for instance a lightning stroke.

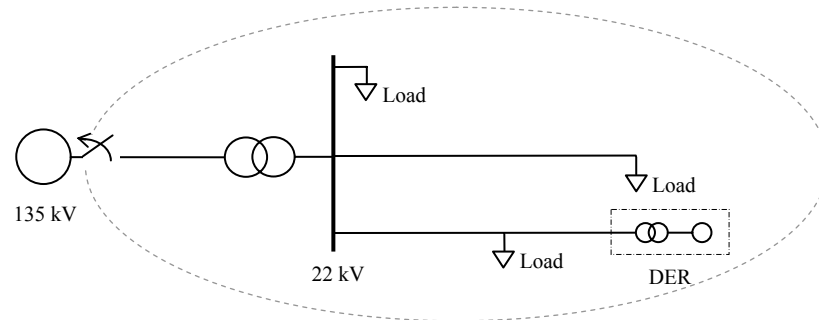

Figure 6.1 Island operation with part of the 130 kV grid.

During the island operation reactive power is fed from the 130 kV-grid to the 20 kV-system. This gives the necessary support of magnetizing current to the induction generator, which therefore can continue to feed the island. This is illustrated in Figure 6.2 - Figure 6.5.

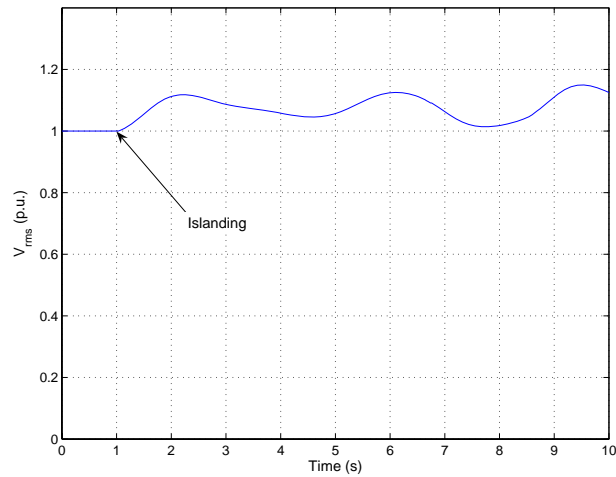

Figure 6.2 Voltage level at the DER plant.

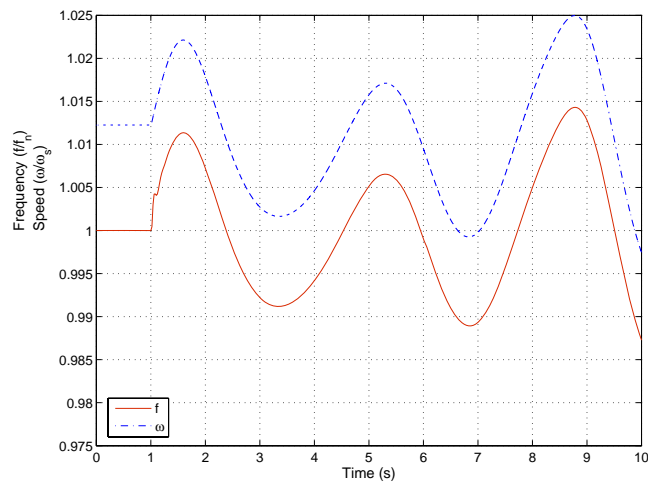

Figure 6.3 Rotational speed of the turbine (upper curve) and frequency (lower curve) at DER-plant. Islanding occurs at the time 1 second.

A small surplus of active power after the islanding initially causes the speed of the generator to increase. As a consequence the frequency also increases, see Figure 6.3. Note that the system does not settle, but instead

the variations grow indicating an unstable system. The question on what to denote the instability arises.

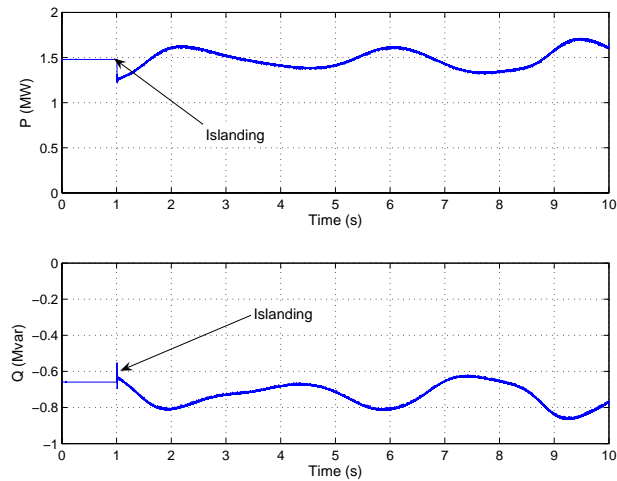

Figure 6.4 Power from the DER-plant.

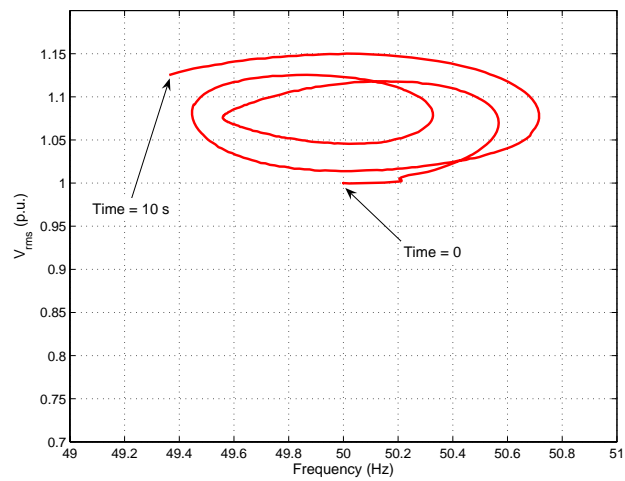

Figure 6.5 Simulation of the voltage of the DER plant as a function of frequency after initiating the island operation.

Oscillations

The Lissajous curve in Figure 6.5 indicates some kind of energy oscillation in the system. To determine the nature of these oscillations a hypothesis was formulated: energy swings back and forth between mechanical and electrical energy storages.

The only possible mechanical energy storage in the simulation model is the rotating masses of the generator and turbine. This part of the energy storage is described by Equation 6.1.

$$W_{kinetic} = \frac{J \cdot \omega^2}{2} \quad (6.1)$$

where J is the moment of inertia of all rotating masses

ω is the mechanical speed

The speed of the generator can be observed in Figure 6.6.a (solid line). To get the speed oscillation a basic cubic curve was fitted to the speed, Figure 6.6.a (dashed line). The speed deviation, presented in Figure 6.6.b, describes the speed oscillation. To get a measure of the energy content in the oscillations the speed deviation was squared according to Equation 6.1, see Figure 6.6.c.

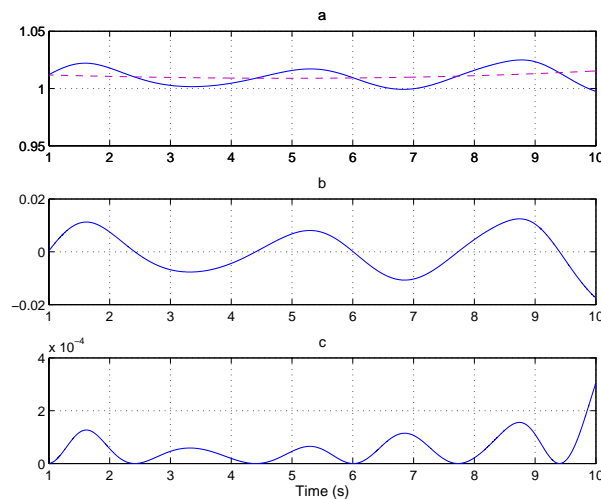

Figure 6.6 a) Turbine rotational speed, ω/ω_s , and calculated medium speed. b) Speed deviation. c) The square of the residual speed is a measure of the swing energy.

The electrical energy is stored either in the capacitances in the grid or in the magnetizing inductance in the generator. A combination of the capacitances and magnetizing inductance is of course also possible. The energies in a capacitance and in an inductance are described in Equation 6.2 and in Equation 6.3.

$$W_c = \frac{C \cdot U^2}{2} \quad (6.2)$$

where C is the sum of capacitances in the grid
 U is the voltage in the grid

$$W_L = \frac{L \cdot I^2}{2} \quad (6.3)$$

where L is the magnetizing inductance of the generator
 I is the magnetizing current in the induction generator

In Figure 6.7 and Figure 6.8 similar calculations are done for the capacitive and inductive energy storages as the one for the mechanical energy in Figure 6.6.

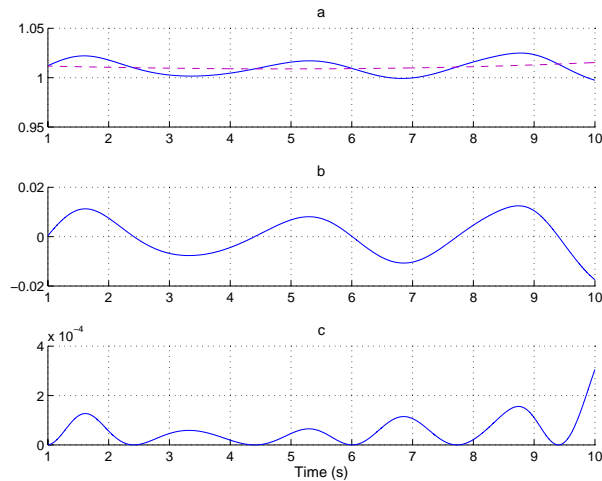

Figure 6.7 a) Voltage level (solid line) and calculated average voltage level (dashed line). b) Residual voltage. c) The square of the residual voltage serves as a measure of the swing energy in the capacitances in the grid.

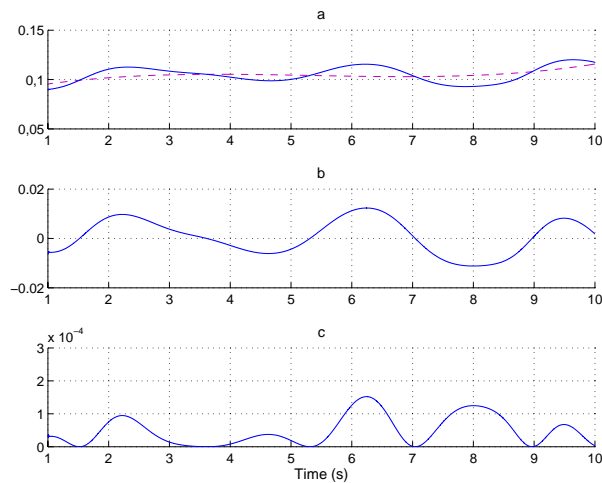

Figure 6.8 a) Magnetizing current in the generator (solid line) and calculated average current (dashed line) in p.u. b) Residual current approximates the swing current through the magnetizing inductance. c) The square of the residual current serves as a measure of the swing energy in the inductance.

In Figure 6.9 the different energy levels of the three different energy storages are compared. From the figure it can be seen that the two electric

energy storages are opposite in phase to the mechanical storage in the generator and turbine. It can therefore be concluded that the Lissajous curve in Figure 6.5 originates from energy swings between electrical storages (capacitive and inductive) and a mechanical storage in the inertia of the generator and turbine.

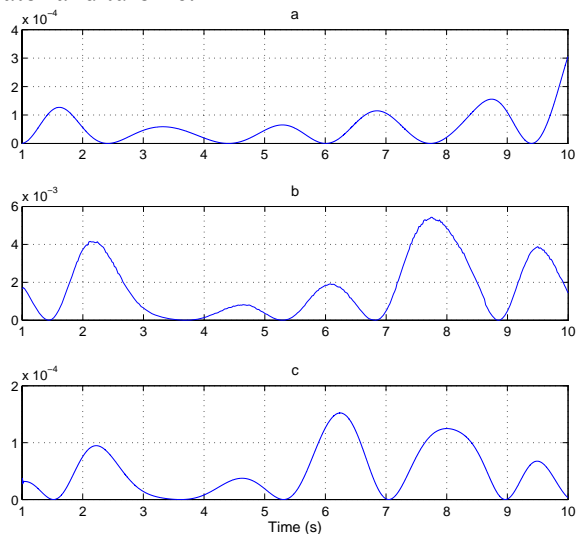

Figure 6.9 Energy in the swings proportional to the square of the a) speed, b) voltage, c) current

The swings seem to be initialized by the small unbalance between active or real power at the formation of the island.

6.2 Islanding with the 20 kV feeder

This is probably the kind of unintended islanding that is considered to be the most frequent event. A feeder breaker opens in the substation and the DER-plant forms an island together with local load. The reason for the breaker to open can be a human mistake or a malfunction of the relay protection. Another cause can be a preceding fault in the feeder. To get a formation that is difficult to detect a plain breaker opening has been used in the simulations. Figure 6.10 illustrates the island formation.

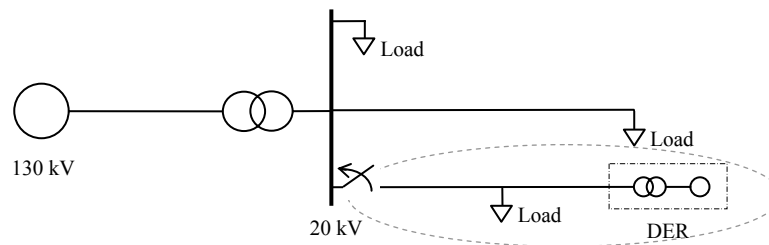

Figure 6.10 Islanding with one feeder and load close to the DER.

During the simulation of this event the load in the feeder was changed to 500 kW and 420 kvar. The wind speed was set to 8 m/s.

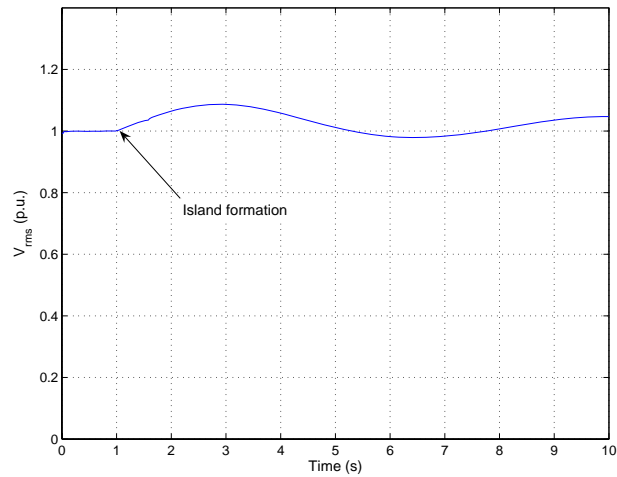

Figure 6.11 Voltage at the DER-unit after island formation.

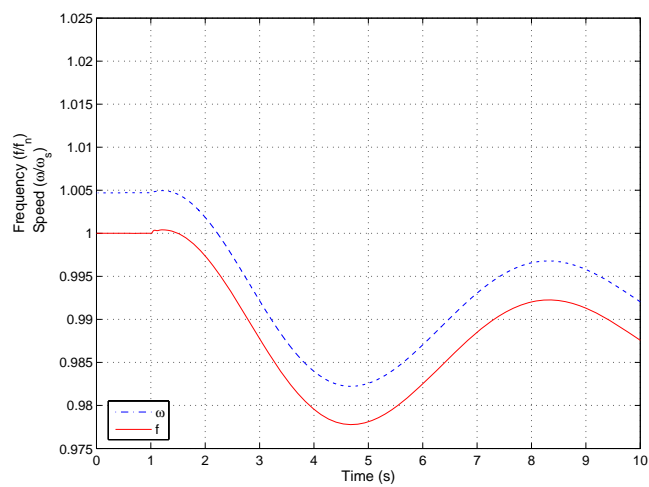

Figure 6.12 Turbine rotational speed (upper curve) and frequency (lower curve) at the DER-plant. The island formation occurs at the time 1 second.

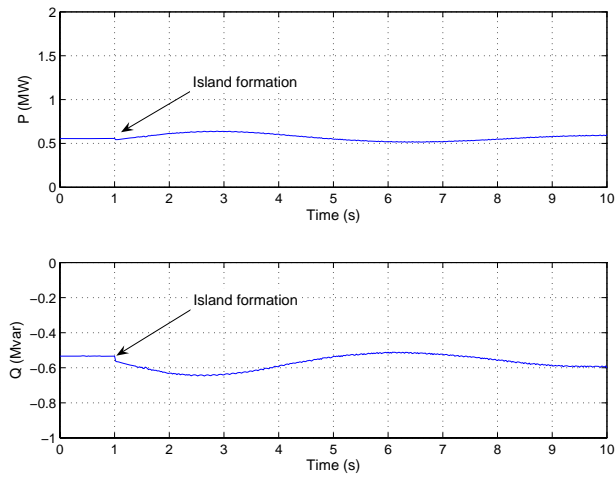

Figure 6.13 Active and reactive power from the distributed generator at islanding with a 20 kV feeder.

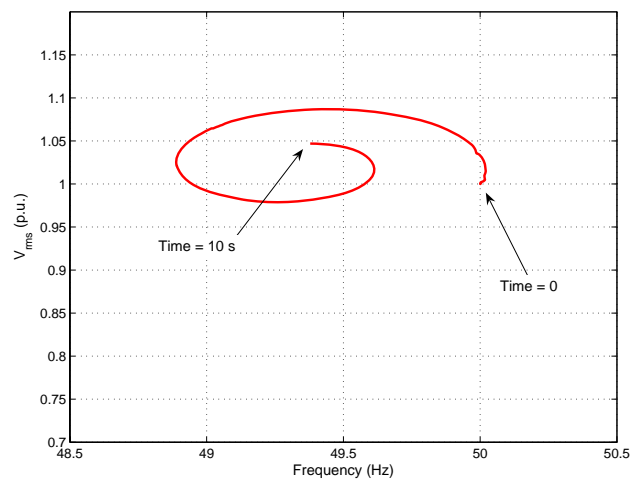

Figure 6.14 Voltage as a function of frequency during island operation with a 20 kV feeder.

A similar Lissajous curve as in Figure 6.5 turns up in Figure 6.14. This is not a coincidence since the same kinds of energy swings are present in this small island as in the island with part of the 130 kV grid involved.

In this case a slightly different behavior can be observed. The swing amplitude has a damping. In Figure 6.5, however, the swings did not converge to a stable operating point, at least not in the short time frame of the simulation.

6.3 Ätran islanding experiment

The Ätran islanding experiment took place in the Valley of Ätran River in south Sweden on 19 April 2004. The experiment was carried out in order to verify new turbine governors that had been installed in a hydro power plant in the system.

The power system that was islanded consists of seven substations fed from five hydro power plants. The total production capability in the small system amounts to 57 MW. At the beginning of the experiment the sum of the loads in the system was approximately 14 MW. Before the islanding the production was adjusted to minimize the interrupted power flow from the strong grid.

All the generators that participated in the production at the experiment were synchronous machines with voltage regulators (AVR) and turbine governors. This is a difference from the islanding simulations in sections 6.1 and 6.2, where neither the voltage nor the frequency were controlled. The voltage performance after islanding can be observed in Figure 6.16. The AVR of the participating generators took over the voltage regulation in the islanded grid and kept it within acceptable limits during the entire experiment.

During the experiment data were collected with PMU:s at three different locations in the small grid. Data used here originates from one of them.

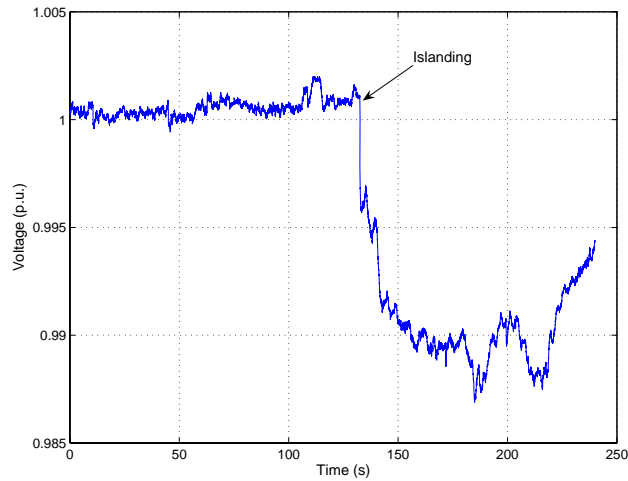

Figure 6.15 Voltage in the Åtran experiment before and after islanding. Note the time scale that differs from that in previous chapters.

The frequency dropped dramatically just after the islanding, as can be seen in Figure 6.16. The turbine governors arrested the decline after some time and brought the frequency back to nominal.

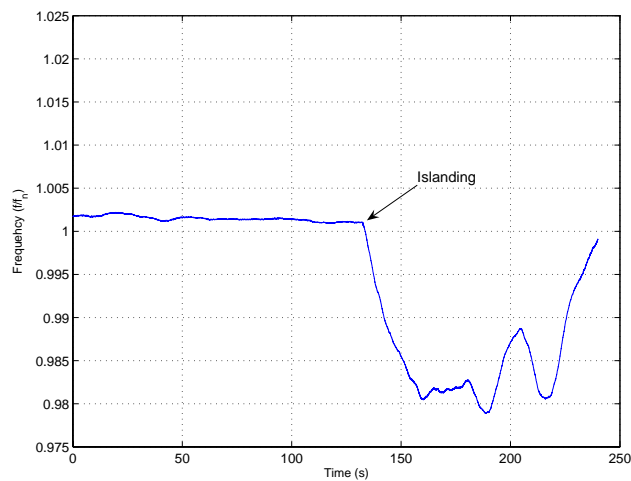

Figure 6.16 Frequency behavior during islanding. Notice the time scale that differs from that in previous chapters.

In Figure 6.17 the frequency-voltage plot is shown. The oscillating performance that could be observed at the simulation of the induction generator is not present, compare with Figure 6.5 and Figure 6.14. This is expected since the turbine governor and the AVR of the synchronous generators counteracts such phenomena.

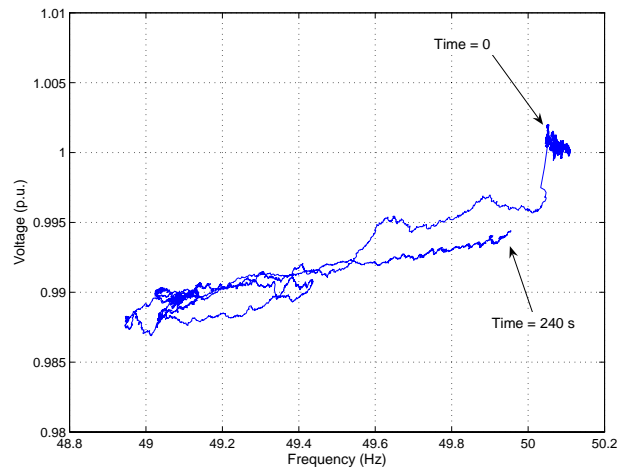

Figure 6.17 Frequency-voltage plot of the first four minutes of the Ätran islanding experiment. Notice that mainly synchronous generators participated in the production during the experiment. Also notice the time scale.

6.4 Parallel connection of transformer

A quite normal procedure in power system operation is to switch in a parallel transformer. This is for instance done when the load gets too heavy for the transformer in operation or when one transformer is taken out of service. From a DER-plant point of view the switching looks like a sudden change in grid impedance, which affects the magnitude of the voltage. The more heavily the first transformer is loaded the more the voltage is affected. During the simulations the load was approximately as large as the nominal power of one transformer, 16 MVA.

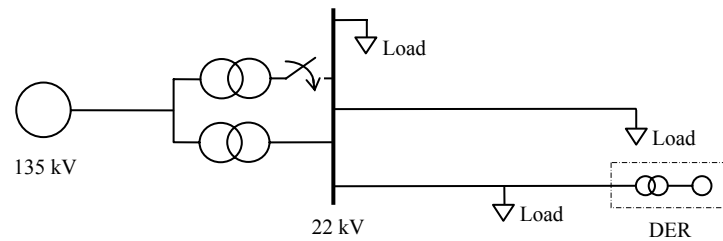

Figure 6.18 Paralleling of transformers.

As the transformer loading is reduced the voltage drop across it is lowered, which can be observed in Figure 6.19. In a longer time frame than the simulation the transformer tap changers would compensate for the large voltage change.

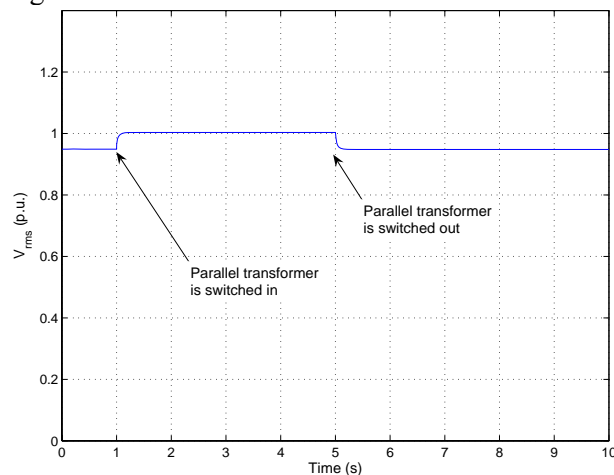

Figure 6.19 Voltage at the DER-plant during switching. Both energizing and de-energizing of the parallel transformer are shown in the figure.

When the voltage is increased at the induction generators terminals the delivered power to the grid is also increased, see Figure 6.21. This can however not go on for very long; since the mechanical power from the turbine not is changed (the wind is assumed constant). The response of the unit is a change in the slip and a new turbine speed, see Figure 6.20.

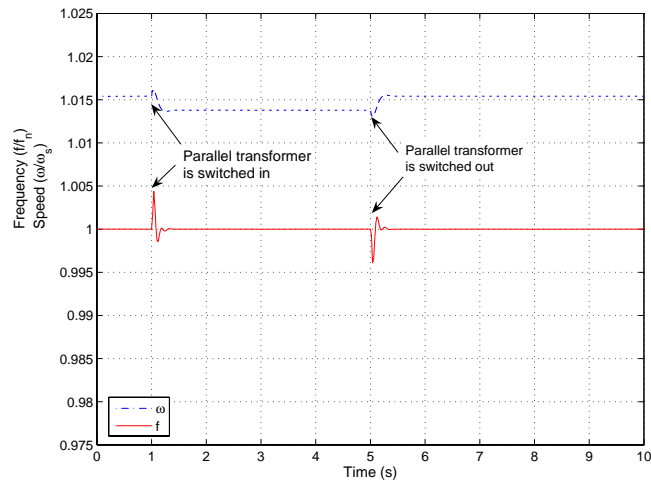

Figure 6.20 Turbine speed (upper curve) and frequency (lower curve) at the DER-plant.

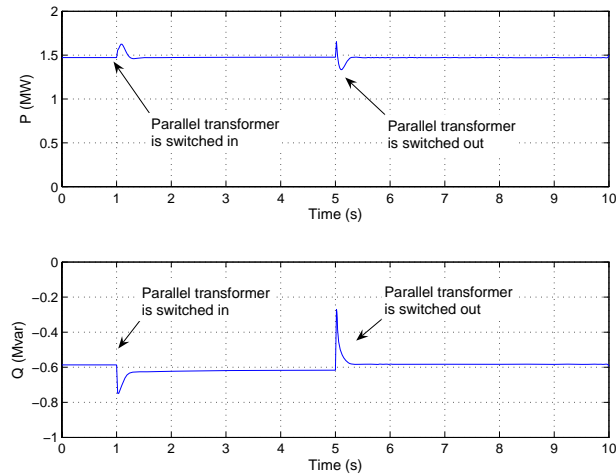

Figure 6.21 Active and reactive power from the distributed generator at switching of a parallel transformer.

In Figure 6.20 a jump in the frequency can be observed. This jump is caused by the transformer switching and can not be seen in the system wide frequency. In Figure 6.22 a) an equivalent circuit has been drawn. E is the voltage vector at the strong grid and X_{grid} is the grid impedance including the transformer reactance. U is the voltage vector at the secondary side of the transformer. Before the parallel transformer is switched in the voltages look like the illustration in Figure 6.22 b). θ denotes the angle between E and U , while φ refers to the phase angle between the voltage U and the load current. When the parallel transformer is energized the grid impedance immediately decreases to its new value. The voltage drop, $X_{\text{grid}} \cdot I_{\text{load}}$, across the transformer changes in the same instant, see Figure 6.22 c). This leads to a change in the voltage vector U , both in magnitude and in angle ($\Delta\theta$). The instantaneous angle change, $\Delta\theta$, causes a corresponding spike in the frequency that can be observed in for instance Figure 6.20.

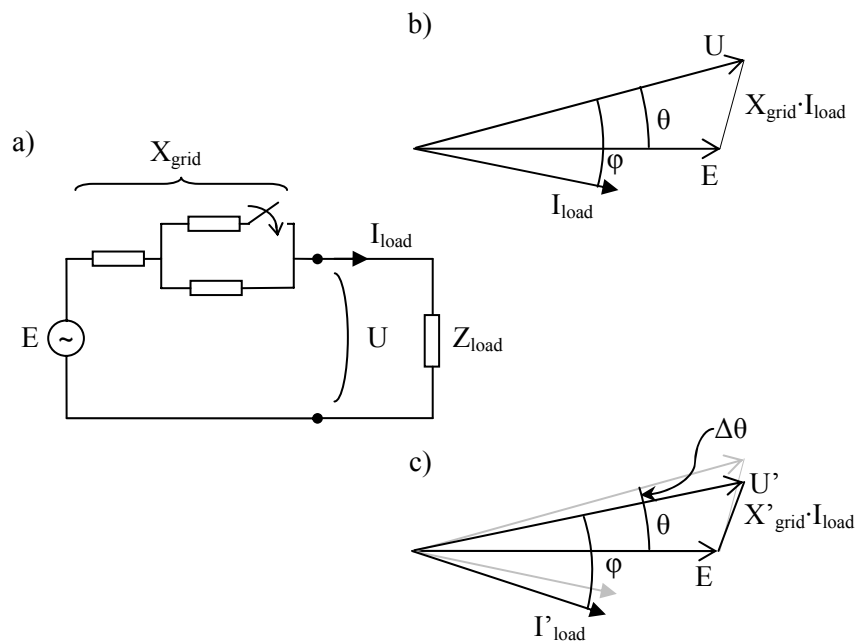

Figure 6.22 Background to the frequency jumps. When the parallel transformer is switched in or out the grid impedance is changed. This causes the voltage vector to jump. The figure has not been made to scale.

The voltage-frequency plot of the transformer switching is shown in Figure 6.23. The curve is clearly not as smooth as the corresponding curve for the islanding cases.

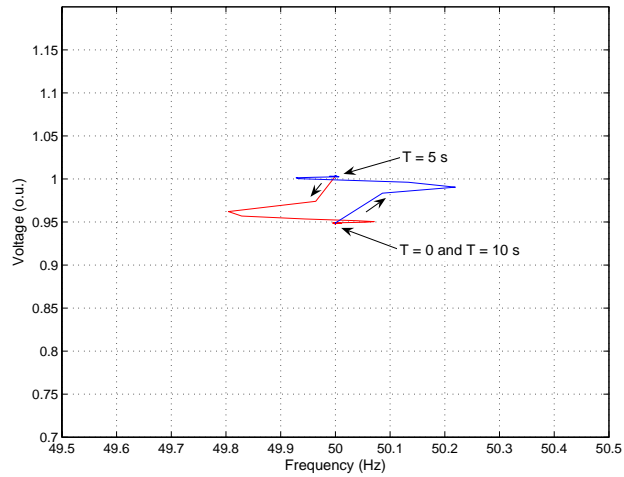

Figure 6.23 Voltage-frequency plot from switching of a parallel transformer. Before the parallel transformer is switched in the voltage is low due to the heavy load situation. When two transformers share the burden the voltage is significantly better.

6.5 Capacitor switching

Shunt capacitor switching is done several times a day in order to regulate the voltage by changing the reactive power flow in the grid. It is normal that switching a capacitor bank affects the voltage level with a few percent. In the model the size of the capacitor was chosen to change the voltage level with approximately 5%, see Figure 6.25. A change of this magnitude during capacitor switching can be considered as a worst case scenario.

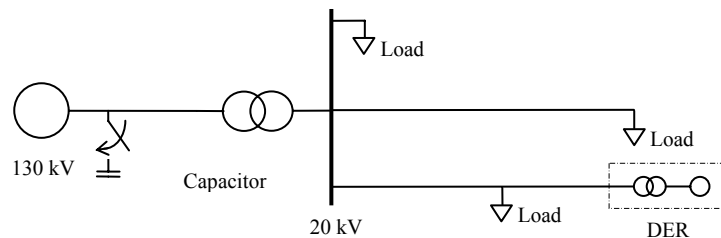

Figure 6.24 Capacitor switching at the 130kV level.

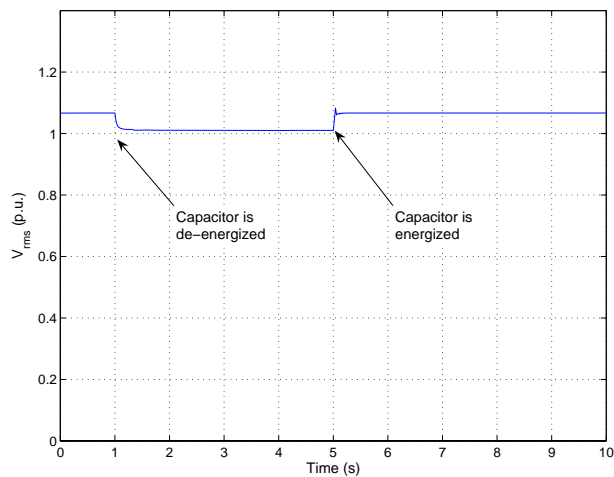

Figure 6.25 Capacitor switch changes the voltage at the distributed power plant with approximately 5%.

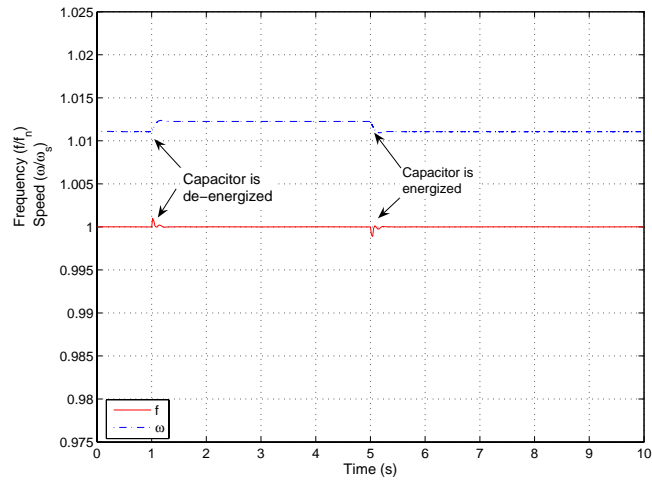

Figure 6.26 Turbine speed (upper curve) and frequency (lower curve) behaviour at capacitor switching.

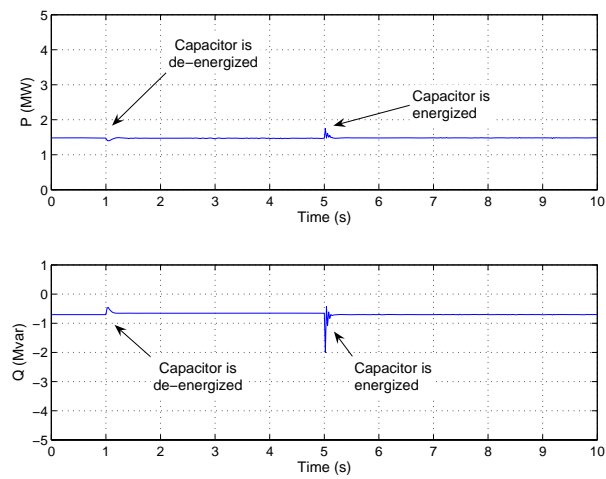

Figure 6.27 Change of active and reactive power flow from the DER-unit during capacitor switching.

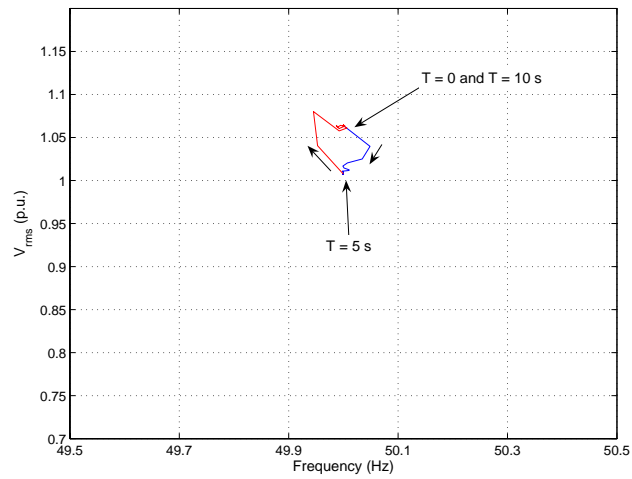

Figure 6.28 The frequency-voltage plot of the capacitor switching events. The curve is not as smooth as during islanding operation.

In Figure 6.28 the frequency-voltage plot of the capacitor switching event can be viewed. It is clear that it is not as smooth as the curve that comes from the island operations. An explanation to the abrupt behavior of the frequency is given in Figure 6.22 and the associating text.

6.6 Loss of bulk power production

On 25 January 2005 in the early morning unit 3 at Oskarshamn nuclear power plant was disconnected from the grid. Before the disconnection 1155 MW was fed to the grid.

The frequency and voltage were recorded with a PMU in a lab at the Department of Industrial Electrical Engineering and Automation at Lund University, located some 350 km from Oskarshamn. The measurements were done on the low voltage connection in the laboratory. But the voltage can by good reasons be believed to reflect the situation on higher voltage levels. See (Samuelsson et al. 2005).

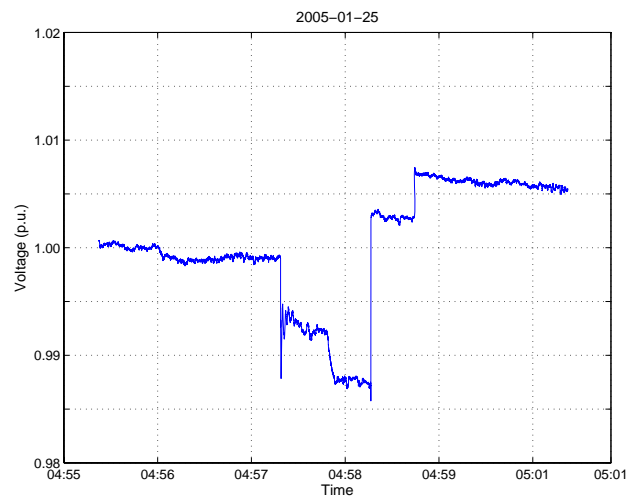

Figure 6.29 Voltage in the lab during the disturbance. After the initial voltage sag transformer tap changers in the system started to compensate for the lower voltage.

The loss of bulk power production mainly affects the frequency, which can be seen in Figure 6.30.

The recordings have been used as input data for simulations of the event.

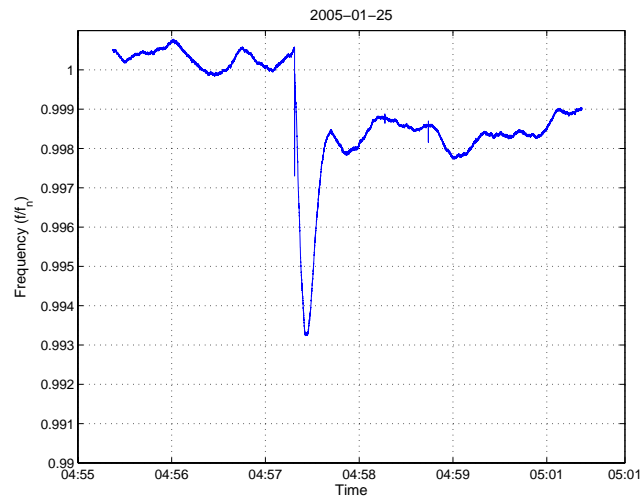

Figure 6.30 Frequency variations due to loss of bulk power production. In the early morning of 25 January 2005 unit 3 of the nuclear power plant in Oskarshamn tripped at a production level of 1155 MW.

6.7 Short-circuit at the 130 kV level

The short-circuit* occurs in the 130 kV grid on a line that connects the transformer to the strong grid, see Figure 6.31. This contingency causes the voltage to dip at the DER-plant, see Figure 6.32. The short-circuit is disconnected after 0.5 seconds, thereafter the DER-unit returns to stable operation, see Figure 6.33 and Figure 6.34.

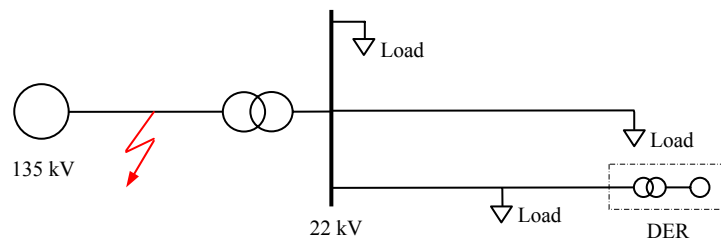

Figure 6.31 Short-circuit in the 130 kV grid.

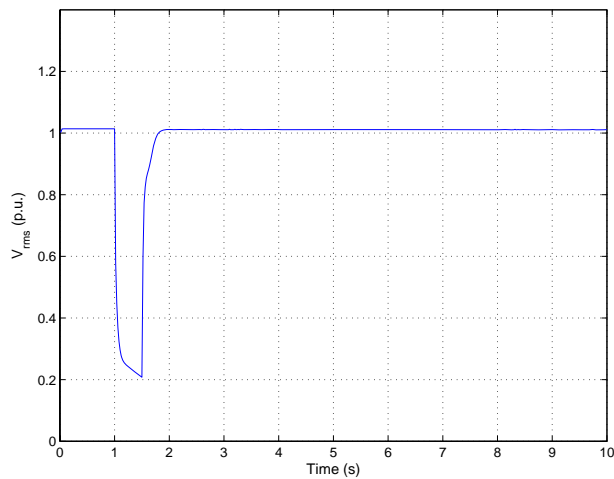

Figure 6.32 Voltage level at the DER-plant during a short-circuit at the 130 kV-level.

* The simulated short-circuits in this Section and the following two are symmetrical three-phase short-circuits.

The voltage dip limits the active power that can be delivered to the load, see Figure 6.34. Instead the power is used to accelerate the turbine, which can be seen in Figure 6.33.

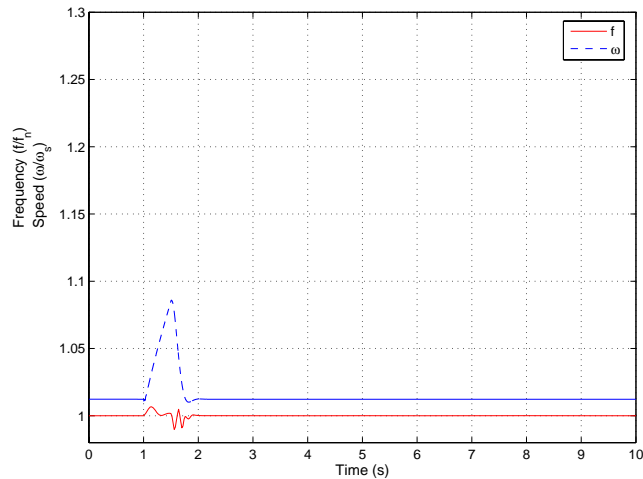

Figure 6.33 Turbine speed and frequency during a short-circuit in the grid.

During the short-circuit period the generator contributes with fault current, which makes it deliver reactive power to the grid. But when the fault is cleared a lot of reactive current needed to magnetize the rotor is drawn from the grid.

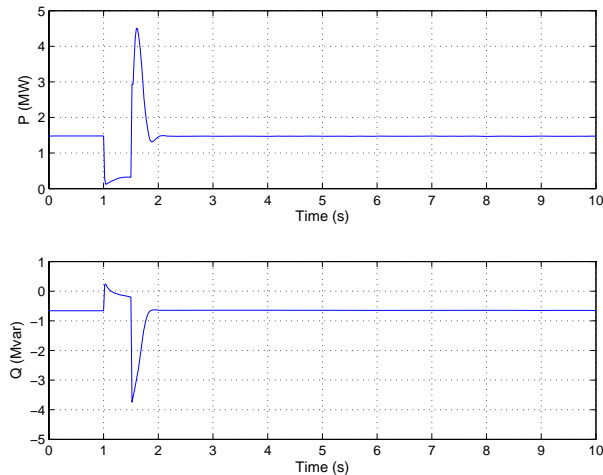

Figure 6.34 Power flow from the DER-plant during the short-circuit at the 130 kV level.

During the short-circuit the frequency at the DER-plant increases according to Figure 6.33. Figure 6.35 a) shows an equivalent circuit. The pre-fault values of voltages and current can be seen in b). A short-circuit occurs at F where the voltage drops to F' , see c). At the same time is the magnitude of the current from the generator increased, which causes the voltage drop over the grid impedance to increase. This makes the voltage vector U shift instantaneous to a new value U' , see c). The vector turn causes the angle θ to shift which is interpreted as a frequency increase in Figure 6.33.

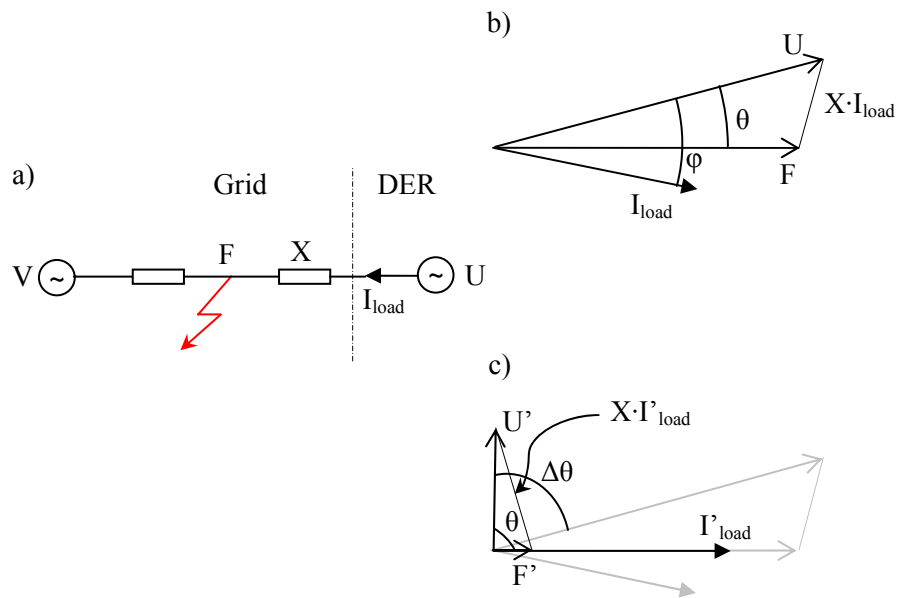

Figure 6.35 a) Equivalent circuit. b) Pre-fault voltages and current. c) Voltage and current vectors during a short-circuit. Observe that the figure has not been made to scale.

In Figure 6.36 the consequences of sudden voltage changes can be observed in a voltage-frequency plot.

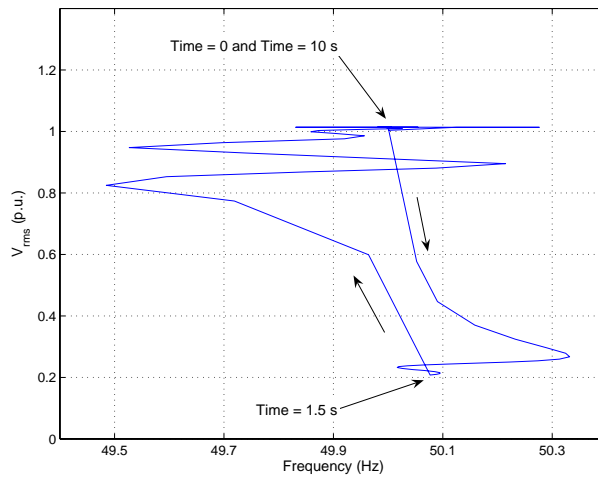

Figure 6.36 Voltage as a function of frequency during the short-circuit at the 130 kV-level.

6.8 Short-circuit in the 20 kV transformer bay

This case has been chosen to stress the system to the edge. A three-phase short-circuit has occurred in the transformer bay between the transformer and the breaker, see Figure 6.37. We assume that the transformer differential relay fails to operate. In this case the so called *single failure criterion*, for which the system has been designed, states that another protection must respond to the contingency. The backup protection for this situation is the overcurrent protection on the 130 kV-side of the transformer. This configuration gives a rather high fault current and a low voltage for a relatively long time (1.5 s), see Figure 6.38.

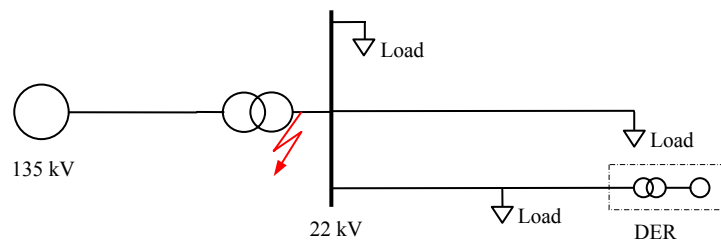

Figure 6.37 A short-circuit occurs in the transformer bay.

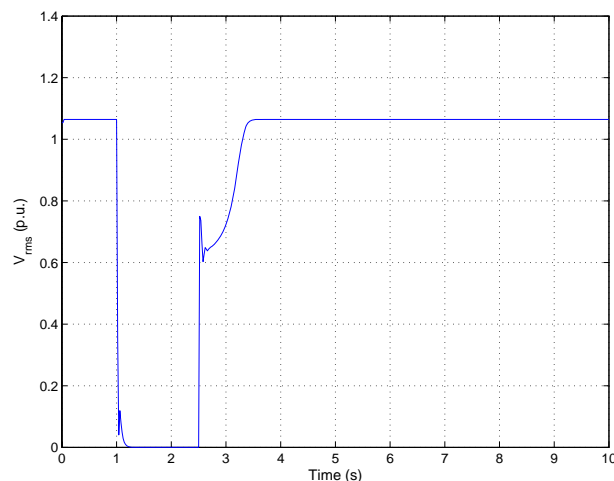

Figure 6.38 The voltage at the DER-plant during a short-circuit in the transformer bay in the feeding substation.

In Figure 6.39 the turbine speed during the fault can be seen (dashed line). A speed increase of almost 30 % is of course not desirable and in a real wind turbine mechanical protection devices should take effect. In the simulation model such protections are not included. This is in order to demonstrate the physical behaviour of the interplay between the generator and the grid.

A similar case has been described in (Samuelsson and Lindahl 2005). In that case the induction generator reached such a speed during the short-circuit that the reactive power needed to magnetize the machine, after the fault clearance, sank the voltage at the terminal. Again the active power delivered to the grid was reduced, which caused the rotor to accelerate so much that it would not return to a level near the nominal value. An unstable operating point had been reached. This is termed rotor speed instability.

In Figure 6.39 also the frequency can be viewed (solid line). The question arises on how the frequency is measured, when there apparently is no voltage present (according to Figure 6.38). The answer is that the fault resistance and the impedance between the fault location and the generator allow a small voltage drop caused by the fault current. Consequently there is a low voltage at the DER-plant, which frequency can be measured. The short-circuit current contribution from the induction generator can be observed in Figure 6.41.

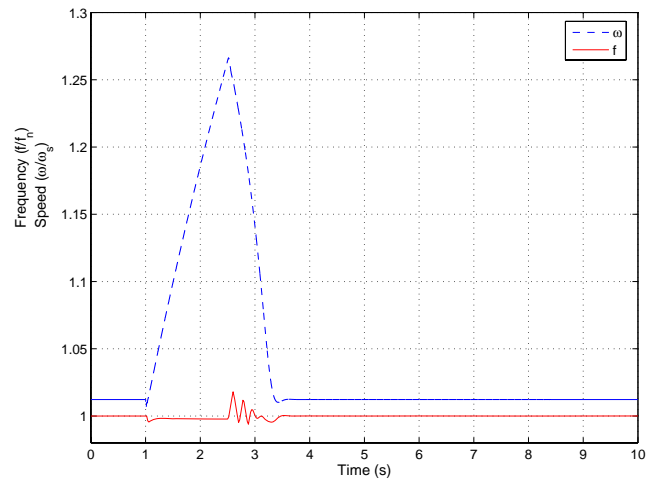

Figure 6.39 Turbine speed and frequency at the DER-plant during a short-circuit in the feeding substation.

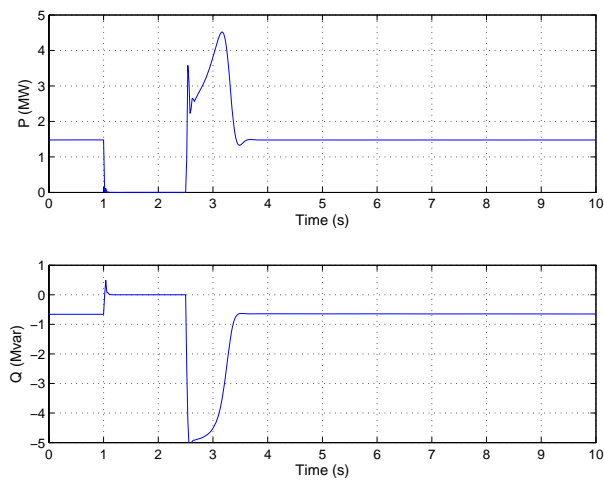

Figure 6.40 Active and reactive power feed from the generator during the disturbance. The active power drops to zero during the fault.

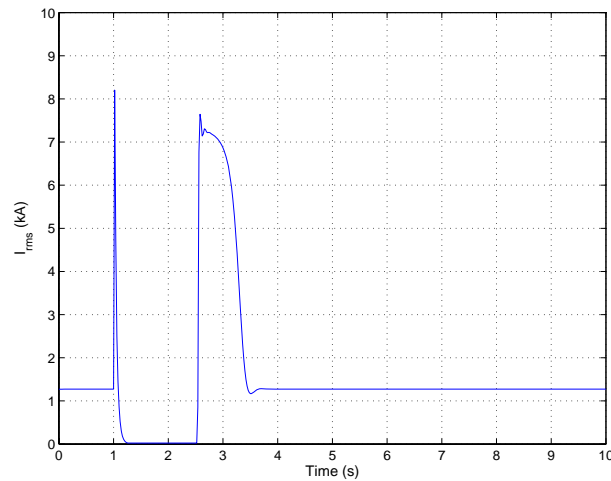

Figure 6.41 Current from the generator during the short-circuit and afterwards.

During the fault, the voltage at the distributed generation plant drops to almost zero, see Figure 6.38. This means that the active power from the turbine can not be delivered to the load, Figure 6.40. During the fault the energy is stored in the turbine and rotor. Hence the speed of the turbine is increased, as can be seen in the upper curve in Figure 6.39. The speed is reduced again as soon as the active power can be delivered to the grid. During the speed reduction a large amount of reactive power is consumed by the induction generator as the rotor is magnetized.

During the severe short-circuit the voltage drops abruptly, which causes the frequency to jump violently, see Figure 6.42. An explanation to this phenomenon is given on page 71.

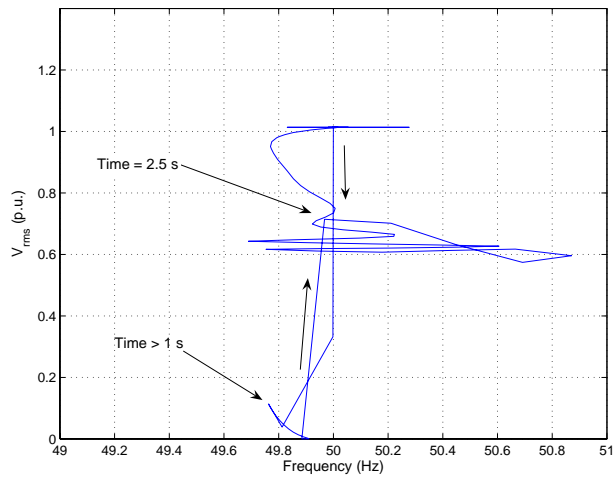

Figure 6.42 Voltage-frequency at the DER-plant during a short-circuit in the feeding substation.

6.9 Short-circuit in an adjacent feeder

A short-circuit occurs at the end of an adjacent feeder, see Figure 6.43. The relatively high source impedance at the fault location gives rise to a rather small fault current. This is the explanation to the long (1.5 seconds) fault clearance time, since dependent time characteristic has been assumed of the overcurrent protection.

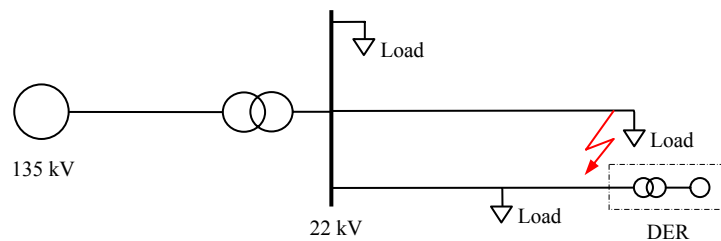

Figure 6.43 Short-circuit in an adjacent feeder causes a small voltage dip in the DER-plant.

The high impedance between the fault and DER-plant also explains the relatively small voltage dip, see Figure 6.44.

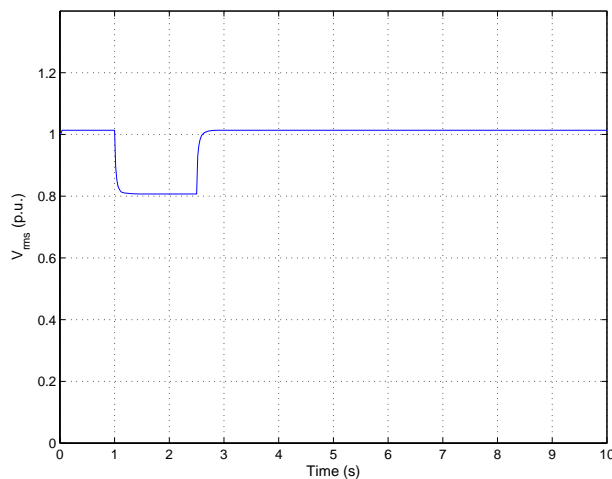

Figure 6.44 The short-circuit in the adjacent feeder lasts for 1.5 seconds. Meanwhile it causes a small voltage dip at the DER-plant.

At the beginning of the fault the voltage dip causes the speed to increase since the amount of power that can be delivered to the grid is decreased. Once the slip has reached a new operating point the power output also settles, see Figure 6.45 and Figure 6.46.

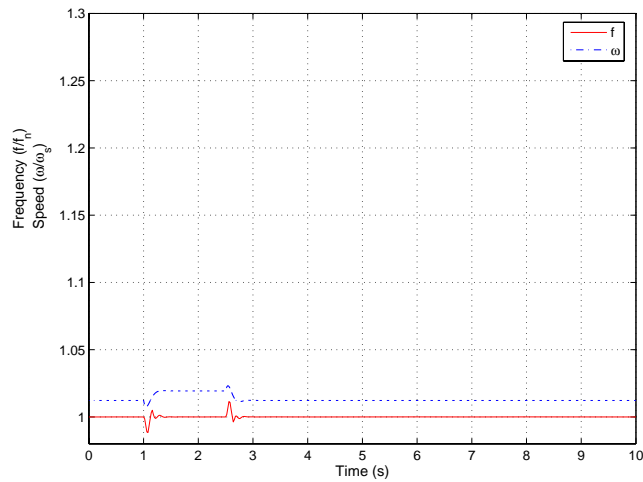

Figure 6.45 Frequency and turbine speed at the DER-plant during a short-circuit in an adjacent feeder.

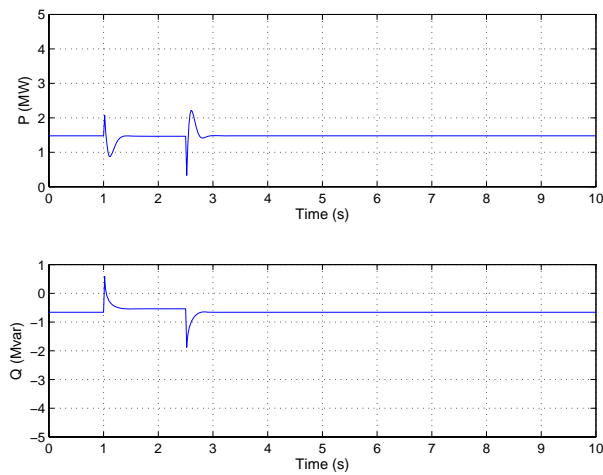

Figure 6.46 Power flow from the DER-plant during a short-circuit in an adjacent feeder.

Figure 6.47 shows the same kind of abrupt changes in voltage and frequency as for the other switching and short-circuits events that have been simulated. On page 71 this is discussed further.

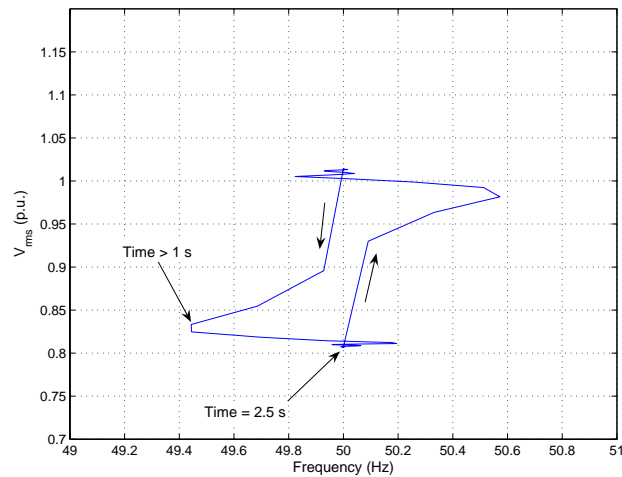

Figure 6.47 Voltage vs. frequency in the DER-plant during short-circuit in an adjacent feeder.

6.10 Summary

In this chapter nine different events in the grid have been introduced and results from simulations of them have been presented. The events have been chosen to reflect a number of incidents. The simulations show how the system voltages and frequencies behave and what an islanding detection device can be expected to be exposed to.

In the next four chapters the algorithms of the different detection methods will be tested on the simulation results of this chapter.

Chapter 7

Voltage measuring relays

Voltage measuring relays have been used for a long time as an easy and inexpensive way to detect islanding. In this chapter their ability to perform will be investigated.

7.1 Settings

A relay protection device needs accurate settings in order to perform well. It is a challenge for relay engineers to choose the proper settings and it is often a compromise between different interests. In this investigation settings that have been taken from the grid codes and standards presented earlier in the thesis will be used.

In this and the following chapters islanding detection relays are studied with simulations. For simplicity reasons the dropout ratio has not been implemented in the simulation model. This means that the dropout value is equal to the pickup value. This has not been considered to restrict the model severely.

AMP

AMP, the Swedish industry standard for connection of DER-units to the grid, has specified operate values for islanding detection devices. The devices consist of under- and overvoltage relays with time delays. The recommended settings are presented in Table 7.1.

Relay	Trip level	Delay time
U<<	0.8 p.u.	0.2 s
U<	0.9 p.u.	60 s
U>	1.06 p.u.	60 s

Table 7.1 AMP voltage settings.

Svenska Kraftnät

The ride-through requirements of Svenska Kraftnät on small and medium sized power plants at voltage disturbances can be viewed in Figure 3.1. The requirement on this category of machines does not involve a voltage ramp which makes relay detection straightforward. The task can be done with only one undervoltage relay. Figure 7.1 and Table 7.2 give the details. The overvoltage settings in Table 7.3 originate from Figure 3.2.

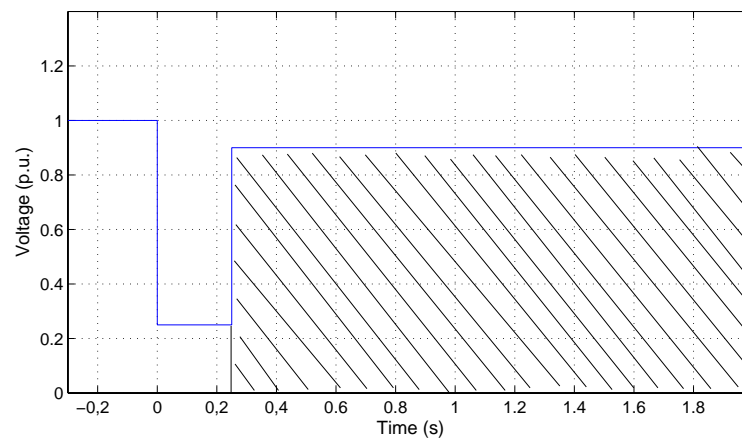

Figure 7.1 The Svenska Kraftnät requirement and the corresponding relay implementation.

Relay	Trip level	Delay time
U<	0.90 p.u.	0.25 s

Table 7.2 Svenska Kraftnät undervoltage settings.

Relay	Trip level	Delay time
U>	1.05 p.u.	0 s

Table 7.3 Svenska Kraftnät overvoltage settings.

Eltra

The ride-through demands of Eltra were presented in Figure 3.5. These demands define how narrow the voltage measuring relays can be set, since no power plant may disconnect unless the voltage drops below the curve. Just like most grid codes Eltra have involved a voltage ramp in their ride-through demands. This ramp is very impractical since almost no commercially available relay protection device has this function implemented. As a compromise in this work the ramp has been replaced with three constant voltage relays with different time delays, see Figure 7.2. The settings can be read from Table 7.4 and Table 7.5.

In Figure 3.6 the dimensioning voltages and frequencies of Eltra were presented. This figure shows under what circumstances a power plant is not allowed to disconnect from the grid. The settings of Table 7.4 and Table 7.5 have been compared with the dimensioning requirements and found to not violate them. Therefore the values of the two tables are used as settings for voltage measuring relays when simulating the Eltra settings.

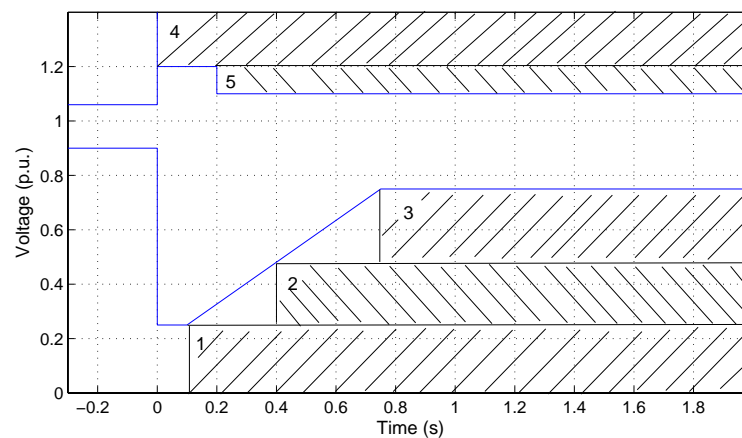

Figure 7.2 The Eltra requirements and the approximation being used by letting three voltage relays with different time delays represent the curve.

Area	Trip level	Delay time
1	0.25 p.u.	0.10 s
2	0.48 p.u.	0.40 s
3	0.75 p.u.	0.75 s

Table 7.4 Eltra undervoltage settings.

Area	Trip level	Delay time
4	1.20 p.u.	0 s
5	1.10 p.u.	0.20 s

Table 7.5 Eltra overvoltage settings.

E.ON

E.ON also has a voltage ramp in the ride-through demands, with the difference that it lasts a little longer. In this investigation the ramp has been replaced with four constant voltage relays with different time settings, see Figure 7.3. The settings have been summarized in Table 7.6.

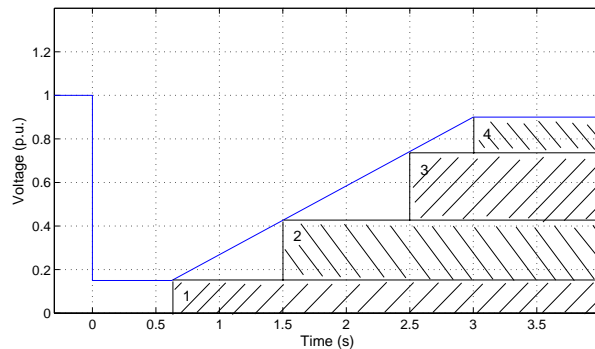

Figure 7.3 E.ON requirements on generators with short-circuit current contribution less than twice the rated current.

Area	Trip level	Delay time
1	0.15 p.u.	0.625 s
2	0.43 p.u.	1.5 s
3	0.74 p.u.	2.5 s
4	0.90 p.u.	3.0 s

Table 7.6 E.ON undervoltage settings.

The settings in Table 7.6 seem to contradict the values that can be read from Figure 3.10 in which generators connected to the 110 kV level have to be dimensioned for two hours operation with a voltage as low as 0.87 p.u. This is due to a simplification of the German grid code, where the correct value depends on the voltage level at the connection point (0.92 p.u. at 380 kV, 0.88 p.u. at 220 kV and 0.87 p.u. at 110 kV). In this context 0.90 p.u. has been used.

For the over-voltage setting a value has been taken from Figure 3.10. At 1.15 p.u. the relay trips the plant without any delay.

Relay	Trip level	Delay time
U>	1.15 p.u.	0 s

Table 7.7 E.ON overvoltage settings.

7.2 Islanding

The islanding detection methods with settings presented above were exposed to islanding situations presented in Sections 6.1 to 6.3. A detection device with perfect dependability detects the situation within an acceptable time frame. On the 130 kV-level *acceptable* means less than 1 second and on the 20 kV-level it is less than 30 seconds (see Section 2.8). The detection times of the different relays can be read from Table 7.8.

Event	Operating time			
	AMP	SvK	Eltra	E.ON
Islanding with part of the 130 kV grid	-	0.48 s	1.04 s	8.5 s
Islanding with 20 kV feeder	-	0.98 s	-	-
Ätran islanding experiment	-	-	-	-

Table 7.8 Operating times at islanding.

7.3 Switching

Switching activities are performed on a daily bases in the grid. An islanding detection relay shall not react upon such events. If it does it is said to have a poor *security*. The results of the simulations are presented in Table 7.9.

Event	Operating time			
	AMP	SvK	Eltra	E.ON
Shunt cap. Switch on	-	-	-	-
Shunt cap. Switch off	-	-	-	-
//-transformer on	-	-	-	-
//-transformer off	-	-	-	-
Loss of bulk power production	-	-	-	-

Table 7.9 The responses of the detection relays to switching activities.

7.4 Short-circuits

Three-phase short-circuits were applied at different locations in the system, see Chapter 6.7 to 6.9. A detection relay with high security does not respond to these contingencies. The results of the simulations are presented in Table 7.10.

Fault location	Operating time			
	AMP	SvK	Eltra	E.ON
130 kV line	0.22 s	0.27 s	0.30 s	-
Transformer bay	0.22 s	0.27 s	0.14 s	0.66 s
End of adjacent feeder	0.38 s	0.29 s	-	-

Table 7.10 The responses of the detection relays to short-circuits in the grid.

7.5 Summary

The operating time of the different methods are presented in Table 7.11. These times shall be compared with the requirements from Chapter 2.8.

A lack of dependability can be noticed since not all islanding situations were detected within an acceptable time (1 s at 130 kV-level and 30 s at 20 kV-level). Even worse is that most islanding situations were not detected at all.

The voltage measuring methods have good security when it comes to switching events in the grid. However, the security is very poor when the relays have to deal with short-circuits in the system. The main reason for this is that short-circuits affect the voltage level in the surrounding grid, while switching events only have a modest influence on the voltage level.

Fault location		Operating time			
		AMP	SvK	Eltra	E.ON
Islanding	Islanding with part of the 130 kV grid	-	0.48 s	1.04 s	8.5 s
	Islanding with 20 kV feeder	-	0.98 s	-	-
	Ätran islanding experiment	-	-	-	-
Switching	Shunt cap. Switch on	-	-	-	-
	Shunt cap. Switch off	-	-	-	-
	//-transformer on	-	-	-	-
	//-transformer off	-	-	-	-
	Loss of bulk power production	-	-	-	-
Short-circuit	130 kV line	0.22 s	0.27 s	0.30 s	-
	Transformer bay	0.22 s	0.27 s	0.14 s	0.66 s
	End of adjacent feeder	0.38 s	0.29 s	-	-

Table 7.11 Summary table.

Chapter 8

Frequency measuring relays

A common way to detect island operation is to use frequency relays. The frequency can easily be measured in all locations of the grid and it is not very expensive. The reliability of frequency measuring relays will be investigated in this chapter.

8.1 Settings

In order to get a broad perspective of the reliability of the frequency measuring relays a number of different settings have been investigated. The settings are reported below.

AMP

The AMP has given detailed instructions on when to disconnect the DER-plant from the grid. The frequency trip levels and time delays can be viewed in Table 8.1.

Relay	Trip level	Delay time
f>	51 Hz	0.5 s
f<	48 Hz	0.5 s

Table 8.1 Trip levels of frequency relays according to AMP.

Svenska Kraftnät

Svenska Kraftnät has not given any specific levels on when to trip a power plant during frequency excursions. Under the assumption that every extra contribution above the requirements results in higher investments in

equipment the trip levels has here been chosen as an inverse of the “must not trip” levels given in the grid code. Compare Figure 3.2 and Table 8.2.

Relay	Trip level	Delay time
f>	53 Hz	0 s
f<	47.5 Hz	0 s

Table 8.2 Trip levels of frequency relays according to Svenska Kraftnät.

Eltra

Eltra have explicit frequency disconnection criteria given in their connection conditions for wind power installations. The values can be seen in Table 8.3.

Relay	Trip level	Delay time
f>	51 Hz	0.2 s
f<	47 Hz	0.2 s

Table 8.3 Trip levels of frequency relays in the grid of Eltra.

E.ON

E.ON has not given the same kind of straightforward criteria of when to disconnect a power plant from the grid as Eltra has. Like in most grid codes E.ON just states under what circumstances a power plant must not trip. Under the same assumptions of cost-benefits as used for Svenska Kraftnät the trip values have been chosen as the inverse of the “must not trip” levels given by the E.ON grid code. Compare Figure 3.10 with Table 8.4.

Relay	Trip level	Delay time
f>	51.5 Hz	0 s
f<	47.5 Hz	0 s

Table 8.4 Trip levels of frequency relays in the transmission grid of E.ON.

Rate of change of frequency

The ROCOF-relay has three settings that have to be determined. The first setting is the df/dt -value (compare with Equation (4.1)). According to (Jenkins, N., et al 2000) typical settings in the UK are between 0.1 and 1.0 Hz/s. A severe loss of bulk power production there may cause a

frequency excursion of as rapid as 1 Hz/s, while frequency changes of 0.2 Hz/s occur relatively often. To get reasonably sensitive detection 0.5 Hz/s was chosen.

The time delay of the relay is the next parameter to choose. The time delay is used to prevent nuisance tripping. (Guillot et al. 2001) recommends not to use shorter time delays than 300 ms with df/dt -settings less than 1 Hz/s. Hence 0.3 seconds is used as time delay for this application.

Finally an undervoltage block level has to be set. This is to prevent nuisance tripping due to short circuits etc. A voltage level of 0.85 p.u. seems reasonable. It is far from the normal operation region and high enough to block for most short-circuits.

Relay	Trip level	Delay time
df/dt	0.5 Hz/s	0.3 s
U < block	0.85 p.u.	

Table 8.5 ROCOF-relay settings.

8.2 Islanding

From Figure 8.1 to Figure 8.4 it is clear that the pure frequency relays with settings according to E.ON and Svenska Kraftnät cannot trip the DER-plant, even if islanding has occurred. A similar figure with Eltra settings would give the same result. It is obvious that the grid codes make islanding detection with traditional methods impossible if there is a good balance between consumption and production in the island.

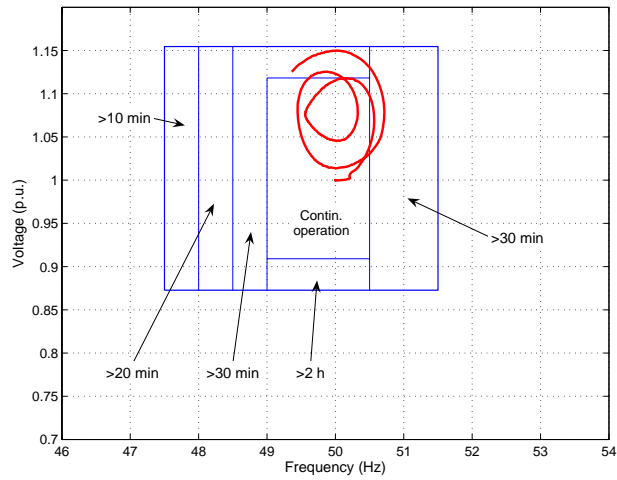

Figure 8.1 Voltage-frequency plot of islanding with part of the 130 kV-grid and the E.ON requirements visualized.

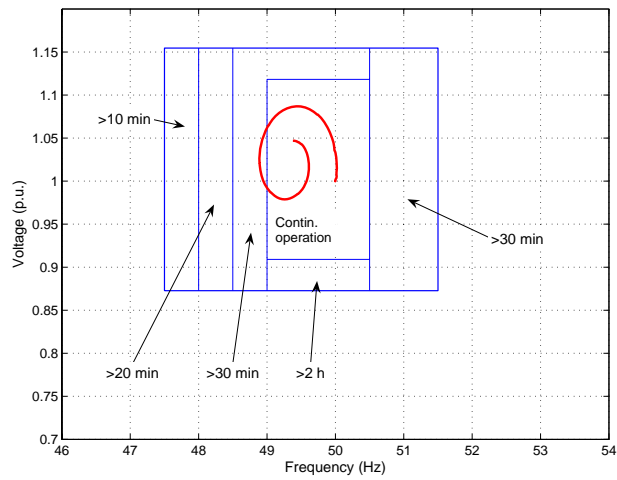

Figure 8.2 Voltage-frequency plot of islanding with a 20 kV feeder and the E.ON requirements visualized.

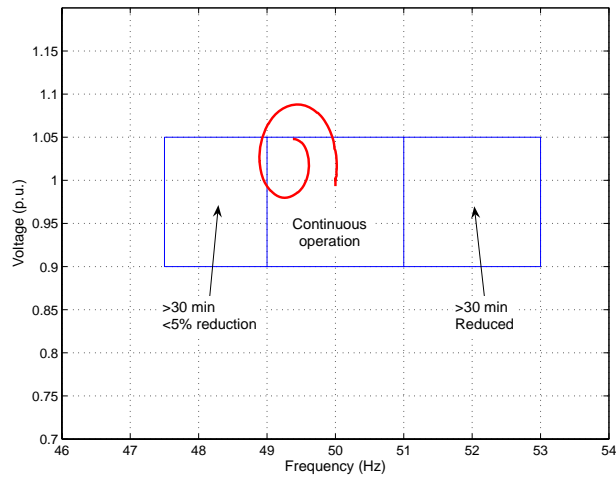

Figure 8.3 Voltage-frequency plot of islanding with a 20 kV feeder and the Svenska Kraftnät requirements visualized

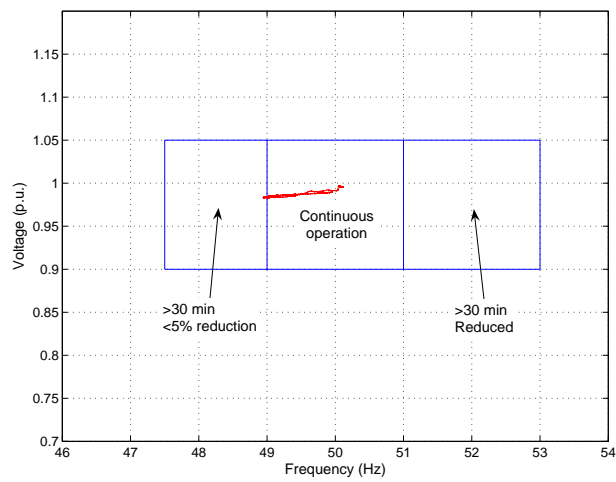

Figure 8.4 Beginning of the Ätran islanding experiment and the Svenska Kraftnät requirements visualized.

In Table 8.6 the detection times of the different methods can be viewed. The method using rate of change of frequency is the only method that actually is able to detect islanding.

Event	Operating time				
	AMP	Svenska Kraftnät	Eltra	E.ON	ROCOF
Islanding with part of the 130 kV grid	-	-	-	-	0.44 s
Islanding with 20 kV feeder	-	-	-	-	1.82 s
Ätran islanding experiment	-	-	-	-	-

Table 8.6 Operating times at islanding.

8.3 Switching

The frequency sensitive relays did not respond to the switching of transformers and shunt capacitors, see Table 8.7. This is quite understandable since these actions mainly affects the voltage level and do not cause any frequency excursions.

Event	Operating time				
	AMP	Svenska Kraftnät	Eltra	E.ON	ROCOF
Shunt cap. Switch on	-	-	-	-	-
Shunt cap. Switch off	-	-	-	-	-
//-transformer on	-	-	-	-	-
//-transformer off	-	-	-	-	-
Loss of bulk power production	-	-	-	-	-

Table 8.7 Operating times at switching events.

8.4 Short-circuits

Three-phase short-circuits were applied in the simulation model. Ideally none of the methods should detect the events. However the 130 kV short-circuit was detected by the ROCOF relay, as can be seen in Table 8.8.

Fault location	Operating time				
	AMP	Svenska Kraftnät	Eltra	E.ON	ROCOF
130 kV line	-	-	-	-	0.82 s
Transformer bay	-	-	-	-	-
End of adjacent feeder	-	-	-	-	-

Table 8.8 Operating times at short-circuits.

8.5 Summary

The operating time of the frequency measuring relays are summarized in Table 8.9.

It is clear the dependability not is satisfying. None of the relays with settings according to the grid codes presented in this thesis were able to detect the different islanding events. The ROCOF relay detected two of three island formations.

The security is better than the dependability. None of the switching events were mistaken for island formations. The short-circuits were also treated rather good, only the ROCOF relay responded to the short-circuit on the 130 kV-level.

Fault location		Operating time				
		AMP	Svenska Kraftnät	Eltra	E.ON	ROCOF
Islanding	Islanding with part of the 130 kV grid	-	-	-	-	0.44 s
	Islanding with 20 kV feeder	-	-	-	-	1.82 s
	Ätran islanding experiment	-	-	-	-	-
Switching	Shunt cap. Switch on	-	-	-	-	-
	Shunt cap. Switch off	-	-	-	-	-
	//-transformer on	-	-	-	-	-
	//-transformer off	-	-	-	-	-
	Loss of bulk power production	-	-	-	-	-
Short-circuit	130 kV line	-	-	-	-	0.82 s
	Transformer bay	-	-	-	-	-
	End of adjacent feeder	-	-	-	-	-

Table 8.9 Summary table of frequency measuring relays.

Chapter 9

Vector shift relays

Vector shift relays are designed to respond to sudden changes in the voltage vector caused by islanding. In this chapter their ability to do so and to discriminate from other events will be examined.

9.1 Settings

The vector shift relay needs two settings. The first is the angle threshold, which defines the lowest degree of vector shift to respond to.

The relay is usually equipped with undervoltage blocking. The purpose of this is to sort out vector shifts caused by short-circuits. The block level is also needed as an input parameter.

The angle threshold was tried out in the simulation model to detect at least one of the islanding cases. 0.9° turned out to be a suitable value. In (Freitas et al. 2005) 2° is mentioned as the lowest value in common relays, but no islanding was detected at that level in the simulations.

The undervoltage blocking level was chosen to block for all nearby short-circuits. The settings are summarized in Table 9.1.

Relay	Trip level
Vector shift	0.9°
Undervoltage blocking	0.85 p.u.

Table 9.1 Settings of the vector shift relay.

9.2 Islanding

The vector shift relay was exposed to the islanding events described in Sections 6.1 to 6.3. The outcome is presented in Table 9.2. a lack of dependability is obvious.

Event	Operating time
Islanding with part of the 130 kV grid	0.02 s
Islanding with 20 kV feeder	-
Ätran islanding experiment	-

Table 9.2 Operating times at islanding.

9.3 Switching

The results from the simulation of the switching events, presented in Table 9.3, shows on a poor dependability.

Event	Operating time
Shunt cap. Switch on	0.02 s
Shunt cap. Switch off	0.02 s
//-transformer on	0.02 s
//-transformer off	0.02 s
Loss of bulk power production	0.02 s

Table 9.3 Operating times at switching events.

9.4 Short-circuits

The vector shift relay was also examined on the short-circuits from Section 6.7 to 6.9. The two nearby events were not detected thanks to the undervoltage blocking device. However, the event at the end of the adjacent feeder was detected, see Table 9.4.

Fault location	Operating time
130 kV line	-
Transformer bay	-
End of adjacent feeder	0.02 s

Table 9.4 Operating times at short-circuits.

9.5 Summary

The behavior of the vector shift relay has been summarized in Table 9.5. Neither the dependability nor the security can be said to satisfying. Only one of the three islanding events was detected and six out of eight other events were wrongly detected as islanding.

Fault location		Operating time
Islanding	Islanding with part of the 130 kV grid	0.02 s
	Islanding with 20 kV feeder	-
	Ätran islanding experiment	-
Switching	Shunt cap. Switch on	0.02 s
	Shunt cap. Switch off	0.02 s
	//-transformer on	0.02 s
	//-transformer off	0.02 s
	Loss of bulk power production	0.02 s
Short-circuit	130 kV line	-
	Transformer bay	-
	End of adjacent feeder	0.02 s

Table 9.5 Summary table of the vector shift relay.

Chapter 10

Methods using communication

Assuming that communication can be utilized there are other possibilities for the detection of islanding. In this chapter the behavior of the COROCOF relay will be described. For practical reasons it was not possible to use data from real events in this part of the work.

10.1 Settings

COROCOF

The comparison of rate of change of frequency relay (COROCOF) consists of two parts. One ROCOF relay installed at a central part of the grid. This relay is called the *sending relay*. At the DER-plant another ROCOF relay is installed, denoted the *generator protection relay*. The sending relay sends a block signal to the DER-unit if it detects a situation interpreted as islanding. See Figure 10.1.

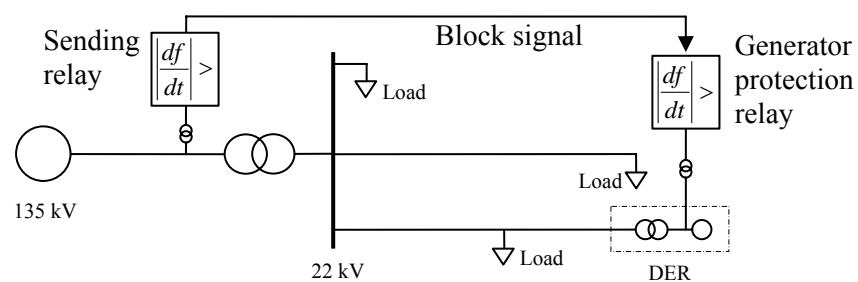

Figure 10.1 The sending relay sends a block signal to the generator protection relay when it detects an islanding situation.

If the generator protection relay senses an island situation without preceding block signal it trips the plant. This means that the sending relay has to be set more sensitive to disturbances to guarantee a block signal. The chosen settings are presented in Table 10.1

	Relay	Trip level	Delay time
Sending relay	df/dt	0.4 Hz/s	0.1 s
Generator protection relay	df/dt	0.5 Hz/s	0.2 s
	U < block	0.85 p.u.	

Table 10.1 COROCOF-relay settings.

10.2 Islanding

In Table 10.2 the detection times of the different islanding events can be viewed. Due to practical circumstances the recordings from the Ätran islanding experiments could not be used.

Event	Operating time
Islanding with part of the 130 kV grid	-
Islanding with 20 kV feeder	1.704 s
Ätran islanding experiment	*

Table 10.2 Operating times at islanding. *) Not tested.

The reason why the COROCOF method could not detect the islanding with part of the 130 kV-grid can be found in the protection configuration. In Figure 10.2 the locations of the sending relay and the generator protection relay can be viewed. Since the sending relay is part of the island it senses the island formation and consequently sends a blocking signal to the generator protection relay. This illustrates the importance of correct protection configuration.

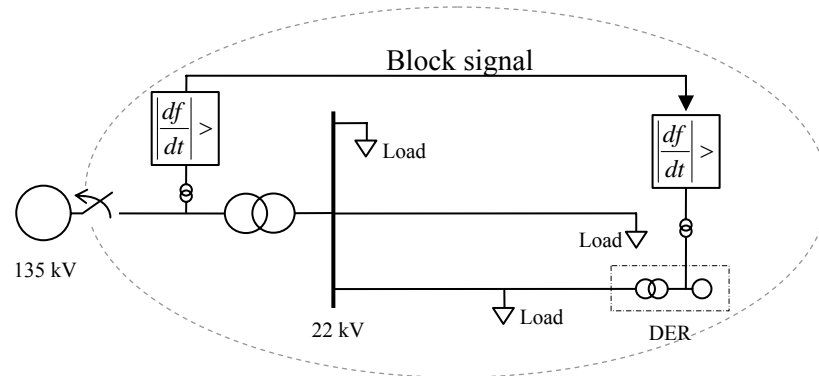

Figure 10.2 COROCOF relay configuration. If the sending relay is part of the island a false block signal will be sent, which prevents the generator protection to act correctly.

10.3 Switching

The COROCOF relays did not respond to the switching of transformers and shunt capacitors, see Table 10.3. This is quite understandable since these actions mainly affect the voltage level and do not cause any frequency excursions. If the loss of bulk power production would have been tested it is not very likely that the COROCOF relay would respond since the frequency excursion was detectable in all system, also by the sending relay.

Event	Operating time
Shunt cap. Switch on	-
Shunt cap. Switch off	-
//-transformer on	-
//-transformer off	-
Loss of bulk power production	*

Table 10.3 Operating times at switching events. *) Not tested.

10.4 Short-circuits

Three-phase short-circuits were applied in the simulation model. The response of the COROCOF relay is presented in Table 10.4.

Fault location	Operating time
130 kV line	-
Transformer bay	-
End of adjacent feeder	-

Table 10.4 The COROCOF relay did not respond to short-circuits.

10.5 Summary

The behavior of the COROCOF relay was investigated in this chapter. The dependability can be very good, but it depends on the location of the sending relay. A poor choice of location leads to false block signals.

The security of the relay turned out to be high. However, the influence of the reliability of the communication link was not part of the investigation.

Chapter 11

Discussion

In Table 11.1 the results from the previous four chapters are summarized. In the islanding columns a 😊 means that the islanding was detected within acceptable time from the formation. A 😞 on the other hand means that the island formation was detected too late or not at all. Lack of dependability is the formal description of these situations.

A 😊 in the columns of switching events and short-circuits indicates that the islanding detection algorithms did not respond at all. The 😞 states that the algorithms reacted to the events, which is undesirable. This is described as lack of security.

As can be seen in Table 11.1 none of the tested algorithms have full dependability and full security. Some of the methods did not even manage to detect one of the three islanding events they were exposed to, while other methods overreacted and responded to switching events and short-circuits.

The results seem to be devastating and the question on how realistic the simulations are arises. Against this can be argued that the recordings from the Ätran islanding experiment were used as a reference. None of the assessed methods could detect that event! However, the other reference case, loss of bulk power, passed all the algorithms correctly.

One conclusion that can be drawn from the result is that there is a need for more research and developments in this area. The methods used today are not as reliable as they should be in a modern power system. Engineers should always struggle to minimize the risks with technology. Here is a good opportunity to do so.

		Event								
		Islanding			Switching			Short-circuits		
Detection method		Islanding with part of the 130 kV grid	Islanding with 20 kV feeder	Ätran islanding	Parallel Transformer Switch	Shunt Cap. Switching	Loss of bulk power production	130 kV-line	Transformer bay	Adjacent feeder
U	AMP	☹	☹	☹	☺	☺	☺	☹	☹	☹
	SvK	☺	☺	☹	☺	☺	☺	☹	☹	☹
	Eltra	☺	☹	☹	☺	☺	☺	☹	☹	☺
	E.ON	☹	☹	☹	☺	☺	☺	☺	☹	☺
f	AMP	☹	☹	☹	☺	☺	☺	☺	☺	☺
	SvK	☹	☹	☹	☺	☺	☺	☺	☺	☺
	Eltra	☹	☹	☹	☺	☺	☺	☺	☺	☺
	E.ON	☹	☹	☹	☺	☺	☺	☺	☺	☺
	ROCOF	☺	☺	☹	☺	☺	☺	☹	☺	☺
Vector Shift		☺	☹	*	☹	☹	*	☺	☺	☹
COROCOF		☹	☺	☹	☺	☺	☺	☺	☺	☺

Table 11.1 Summary table. The symbols indicate the functionality of the relays at different events. The symbol ☺ means that the response was successful, while ☹ shows on the opposite. * Two cases could not be tested for practical reasons.

Until the problem with reliable islanding detection has been finally solved the author wants to strongly recommend that automatic reclosing equipment is outfitted with line-side voltage supervision as soon as the feeder has DER-plants connected. This eliminates the risk of out of phase reclosing and overvoltages from capacitive switching transients.

Chapter 12

Conclusions

With this chapter the thesis is concluded. The results from previous chapters are summarized and some ideas for future work are presented.

12.1 Findings

In Chapter 6 electro-mechanical energy oscillations after islanding were discussed. The oscillations give rise to Lissajous figures in the frequency-voltage plane. This could be a way to detect islanding if further developed. The question on what to denote the instability was aroused.

Most grid codes have a ramp in their voltage disturbance ride-through requirement. In Chapter 7 this voltage ramp was found to be difficult to thoroughly implement in algorithms. It is also impractical since almost no commercially available relay protection device has this function implemented.

In Chapter 8 it was revealed that the grid codes do not permit frequency and/or voltage relays to detect islands if there is a good balance between load and production. The detection time becomes unacceptable long. If a feeder has DER-units installed it is therefore strongly recommended that automatic reclosing equipment is outfitted with line-side voltage supervision.

From the simulation results presented in Chapter 11 the conclusion can be drawn that reliability of the assessed islanding detection algorithms is low. Neither the security nor the dependability is satisfying.

12.2 Future work

In this section a few suggestions for future work are summarized.

The thesis has focused on induction generators connected to the grid. It would be of interest to repeat the work with synchronous generators and power electronic converters as well as double feed induction generators.

There are a number of different grid codes published by transmission system operators and similar organizations. There are many similarities but also some differences between them. An investigation to explain the reasons for this could be motivated since the physics behind the codes are more or less the same.

It would be interesting to investigate if the Lissajous figures in the frequency-voltage plane can be utilized for islanding detection. This work should be extended to also include the behavior of synchronous generators and power electronic converters. Their capability to regulate voltage and frequency is likely to counteract the oscillations.

The ride-through requirements are almost impossible to implement in commercially available relays today. A critical review of the current grid codes and their appliance would be useful. This could be followed by research on alternative ways to implement the requirements.

References

- Ackermann, T., Andersson, G. and Söder, L. (2001). "Distributed generation: a definition", *Electric Power Systems Research*, vol. 57, no. 3, pp. 195-204.
- Borbely, A.-M. and Kreider, J. F. (2001). *Distributed generation: the power paradigm for the new millennium*. Boca Raton: CRC Press.
- Bright, C. (2001). "COROCOF: comparison of rate of change of frequency protection. A solution to the detection of loss of mains", In: *Seventh International Conference on Developments in Power System Protection*. pp. 70-73.
- E.ON Netz GmbH (2003). *Grid Code*. Bayreuth, Germany.
- Elkraft system and Eltra (2004a). *Vindmøller tillsluttet net med spændinger over 100 kV*. Denmark.
- Elkraft system and Eltra (2004b). *Vindmøller tillsluttet net med spændinger under 100 kV*. Denmark.
- Eltra (2000). *Noget om Eltra*. Fredericia: Eltra.
- Fox, B. and O Kane, P. J. (1998). *Identifying loss of mains in electricity distribution system*, Patent Number: GB2317759
- Freitas, W., Huang, Z. and Xu, W. (2005a). "A Practical Method for Assessing the Effectiveness of Vector Surge Relays for Distributed Generation Applications", *IEEE Transactions on Power Delivery*, vol. 20, no. 1, pp. 57-63.
- Freitas, W., Xu, W., Affonso, C. M. and Huang, Z. (2005b). "Comparative Analysis Between ROCOF and Vector Surge Relays for Distributed Generation Applications", *IEEE Transactions on Power Delivery*, vol. 20, pp. 1315- 1324.

- Funabashi, T., Koyanagi, K. and Yokoyama, R. (2003). "A review of islanding detection methods for distributed resources", In: *Power Tech Conference Proceedings, 2003 IEEE Bologna.*, Bologna.
- Greenwood, A. (1971). *Electrical transients in power systems*. New York: Wiley.
- Guillot, M., Collombet, C., Bertrand, P. and Gotzig, B. (2001). "Protection of embedded generation connected to a distribution network and loss of mains detection", In: *CIRE2001*.
- IEEE (2000). *IEEE 100: The authoritative dictionary of IEEE standards terms*. New York: Standards Information Network.
- IEEE (2003a). *IEEE Standard for interconnecting distributed resources with electric power systems*, IEEE Std 1547.
- IEEE (2003b). *IEEE guide for automatic reclosing of line circuit breakers for AC distribution and transmission lines*, IEEE Std C37.104-2002.
- International Energy Agency (2005). Available:
<http://www.pvdatabase.com/search_results.cfm?Mode=Products>
[2005-10-23].
- Ishibashi, A., Imai, M., Omata, K., Sato, S., Takagi, T., Nakachi, Y. and Ogawa, S. (2004). "New type of islanding detection system for distributed generation based on voltage angle difference between utility network and distributed generation site", In: *Eighth IEE International Conference on Developments in power system protection*. pp. 542-545.
- Jenkins, N., Allan, R., Crossley, P., Kirschen, D. and Strbac, G. (2000). *Embedded generation*. London: The Institution of Electrical Engineers.
- Kundur, P. (1994). *Power system stability and control*. New York: McGraw-Hill.
- Redfern, M. A., Barrett, J. I. and Usta, O. (1997). "A new loss of grid protection based on power measurements", In: *Developments in Power System Protection, Sixth International Conference on (Conf. Publ. No. 434)*. pp. 91-94.

- Reid, R., Saulnier, B. and Gagnon, R. (). *Wind Turbine Asynchronous Generator in Isolated Network*, The MathWorks, (Matlab and Simulink).
- Ropp, M., Begovic, M. and Rohatgi, A. (1999). "Analysis and performance assessment of the active frequency drift method of islanding prevention", *IEEE Transaction on Energy Conversion*, vol. 14, no. 3, pp. 810-816
- Salman, S., King, D. and Weller, G. (2001). "New loss of mains detection algorithm for embedded generation using rate of change of voltage and changes in power factors", *Seventh International Conference on Developments in Power System Protection (IEE)*, pp. 82-85
- Samuelsson, O., Hemmingsson, M., Nielsen, A. H, Pedersen, K. O. H and Rasmussen, J. (2005). "Monitoring of power systems events at transmission and distribution level", accepted for publication in *IEEE Transactions on Power Systems*.
- Samuelsson, O. and Lindahl, S. (2005). "On Speed Stability", *IEEE Transactions on Power Systems*, vol. 20, no. 2, pp. 1179-1180.
- Solceller i byggandet (2005). Available: <<http://www.solcell.nu/>> [2005-10-23].
- Svensk Energi (2002). *Anslutning av mindre produktionsanläggningar till elnätet*.
- Svenska Kraftnät (2005). *Affärsverket svenska kraftnäts föreskrifter och allmänna råd om driftsäkerhetsteknisk utformning av produktionsanläggningar*. Stockholm, Sweden.
- Tang, L. and Zavadil, R. (1993). "Shunt capacitor failures due to windfarm induction generator self-excitation phenomenon", *IEEE Transaction on Energy Conversion*, vol. 8, no. 3, pp. 513-519.
- Warin, J.W. "Loss of Mains Protection", *ERA Conference on Circuit Protection for Industrial and Commercial Installations*, 1990, London