



# LUND UNIVERSITY

## The Family of Belykh Maps

Persson, Tomas

2005

[Link to publication](#)

*Citation for published version (APA):*

Persson, T. (2005). *The Family of Belykh Maps*. [Licentiate Thesis, Mathematics (Faculty of Engineering)].

*Total number of authors:*

1

### General rights

Unless other specific re-use rights are stated the following general rights apply:

Copyright and moral rights for the publications made accessible in the public portal are retained by the authors and/or other copyright owners and it is a condition of accessing publications that users recognise and abide by the legal requirements associated with these rights.

- Users may download and print one copy of any publication from the public portal for the purpose of private study or research.
- You may not further distribute the material or use it for any profit-making activity or commercial gain
- You may freely distribute the URL identifying the publication in the public portal

Read more about Creative commons licenses: <https://creativecommons.org/licenses/>

### Take down policy

If you believe that this document breaches copyright please contact us providing details, and we will remove access to the work immediately and investigate your claim.

LUND UNIVERSITY

PO Box 117  
221 00 Lund  
+46 46-222 00 00

The family of Belykh maps

# THE FAMILY OF BELYKH MAPS

TOMAS PERSSON



LUND INSTITUTE OF TECHNOLOGY  
Lund University

Centre for Mathematical Sciences  
Mathematics

Tomas Persson

2005

CENTRUM SCIENTIARUM MATHEMATICARUM

# THE FAMILY OF BELYKH MAPS

TOMAS PERSSON



LUND INSTITUTE OF TECHNOLOGY  
Lund University

Centre for Mathematical Sciences  
Mathematics

Mathematics  
Centre for Mathematical Sciences  
Lund University  
Box 118  
SE-221 00 Lund  
Sweden  
<http://www.maths.lth.se/>

Licentiate Theses in Mathematical Sciences 2005:1  
ISSN 1404-028X

ISBN 91-631-6468-X  
LUTFMA-2014-2005

© Tomas Persson, 2005

Printed in Sweden by KFS, Lund 2005

### **Abstract**

In this thesis we study a class of non-invertible piecewise affine hyperbolic systems with discontinuities in two dimensions. This is a special class of systems but it reflects many properties of more general non-invertible hyperbolic systems.

For a special subset of parameters the system is especially simple. In this case the system reduces to a one-dimensional system and methods from one-dimensional dynamics can be applied. We classify the ergodic properties in terms of the associated subshift and the number-theoretical properties of the parameter.

We show that for an open set of parameters the Sinai-Bowen-Ruelle measure is absolutely continuous with respect to Lebesgue measure and the correlations of Hölder continuous functions decay exponentially.



### **Acknowledgements**

I want to thank the sharp-minded Jörg Schmeling, my supervisor, for great support and encouragement. He has made my days interesting and joyful. I also thank my co-supervisor Sergei Silvestrov.

Finally, I want to thank my father, Hans Persson. He taught me the most important thing about mathematics — it is fun.





# Contents

<b>1</b>	<b>Introduction</b>	<b>9</b>
<b>2</b>	<b>Restriction to one dimension</b>	<b>15</b>
2.1	Definition of the system . . . . .	15
2.2	The one-dimensional case . . . . .	15
2.2.1	A subshift with two kneading sequences . . . . .	15
2.2.2	Classification of the subshifts . . . . .	17
2.2.3	Invariant measures . . . . .	21
2.2.4	Ergodic properties . . . . .	27
2.2.5	Connection to algebraic numbers . . . . .	29
2.2.6	Distance to the singularity and return times . . . . .	35
2.2.7	Decay of correlations . . . . .	39
<b>3</b>	<b>Absolutely continuous invariant measure for a class of piecewise affine hyperbolic endomorphisms</b>	<b>43</b>
3.1	Introduction . . . . .	43
3.2	The class of endomorphisms . . . . .	44
3.3	Absolutely continuous invariant measure . . . . .	47
3.4	Proof of the theorem . . . . .	47
3.5	Decay of correlations . . . . .	55



## Chapter 1

# Introduction

This thesis is a study of a class of non-invertible hyperbolic maps on the square, called the Belykh systems. These systems are piecewise affine and hyperbolic. The simple form of the Belykh maps make them easier to work with and they are hoped to share many properties with more general classes of non-invertible hyperbolic systems. We hope that the study of the Belykh maps will contribute to a better understanding of non-invertible hyperbolic systems and that the methods can be generalised to a broader class of systems.

In [27], Pesin studied a general class of piecewise diffeomorphisms with a hyperbolic attractor. He showed the existence of the Sinai-Bowen-Ruelle measure, or SBR-measure for short, and studied the ergodic properties of this measure. If  $f : M \rightarrow M$  is the system in question then the SBR-measure is a weak limit point of the sequence of measures

$$\mu_n = \sum_{k=0}^{n-1} \nu \circ f^{-k},$$

where  $\nu$  denotes the Lebesgue measure. This measure is the physically relevant measure as it captures the behaviour of the orbits of points from a set of positive Lebesgue measure. Pesin showed that the SBR-measure has at most countably many ergodic components. For a more restricted class, Sataev [29] showed that there are only finitely many ergodic components. In [30] he used this result to prove that under a condition on the parameters, the Belykh map is ergodic. Schmeling and Troubetzkoy studied in [33] a more general class than Pesin's and proved the existence of the SBR-measure. Their method to deal with the non-invertibility of the system was to lift the system to a higher dimension and get an invertible system on which the calculations was made. In this way methods from invertible systems could be used. The result could then be projected back to the original system.

Among the above mentioned classes are the Belykh systems. These systems were first studied in [5] as a model of the Poincaré map of a system of differential equations coming from the study of phase synchronisation. In [33] and [32], Schmeling and Troubetzkoy studied the Belykh systems for a wider class of parameters. These systems are especially simple but it is hoped that they reflect many interesting properties of Pesin's class and that the method used for Belykh systems can be generalised to investigate a broader class of systems.

The Belykh map is defined as follows. Let  $Q = [-1, 1]^2$  and define the

Belykh map  $f : Q \rightarrow Q$  by

$$f(x, y) = \begin{cases} (\lambda x + (1 - \lambda), & \gamma y - (\gamma - 1)), & \text{if } y > kx, \\ (\lambda x - (1 - \lambda), & \gamma y + (\gamma - 1)), & \text{if } y < kx, \end{cases}$$

where the parameters are  $0 < \lambda \leq 1$ ,  $-1 < k < 1$  and  $1 < \gamma \leq \frac{2}{1+|k|}$ . See Figure 1.1. In this work we will study a similar map with the only difference that the singularity set is the set  $([-1, 0] \times \{-k\}) \cup (\{0\} \times [-|k|, |k|]) \cup ([0, 1] \times \{k\})$  instead of  $\{y = kx\}$ , that is we approximate the line  $\{y = kx\}$  with a piecewise constant curve.

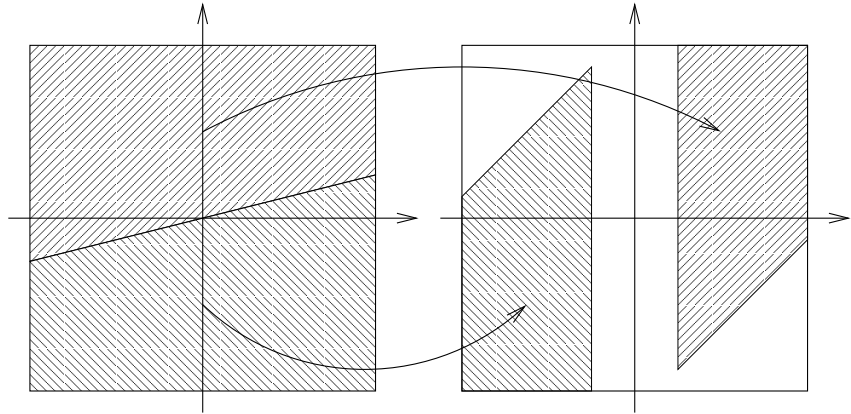

Figure 1.1: The Belykh map for  $\gamma = \frac{3}{2}$ ,  $\lambda = \frac{3}{8}$  and  $k = \frac{1}{4}$ .

We show that when the map expands area ( $\gamma\lambda > 1$ ) then there is an open set  $P$  of parameters such that the SBR-measure is absolutely continuous with respect to Lebesgue measure almost surely if the parameters are in  $P$ .

There are similar results in the literature. In the case when  $k = 0$  and  $\gamma = 2$  the system is the fat baker's transformation, studied by Alexander and Yorke in [1]. In this case the map is the product of its projections to the first and the second coordinate. The projection on the second coordinate is the two-shift. This simplifies the calculations and the SBR-measure is the product of the one-dimensional Lebesgue measure and a Bernoulli convolution. The result of Solomyak in [35] implies that for Lebesgue almost every parameter the fat baker's transformation has an SBR-measure which is absolutely continuous with respect to the Lebesgue measure. Alexander and Yorke showed that if  $\lambda^{-1}$  is a Pisot number then the SBR-measure is singular to the Lebesgue measure, since then the Fourier transformation of the Bernoulli convolution does not tend

---

to zero at infinity and hence can not be absolutely continuous with respect to Lebesgue measure, [11].

In the case of expanding maps, that is maps that eventually are expanding in every direction, much is known. Buzzi, [3], and Tsujii, [36] showed independently that any expanding piecewise analytic map of the plane has an absolutely continuous invariant measure. In higher dimensions Tsujii [37] showed that any expanding map which is piecewise affine on finitely many polyhedral pieces has an absolutely continuous invariant measure. Buzzi showed in [2] that almost any expanding map which is piecewise affine on a more general type of pieces has an absolutely continuous invariant measure.

Let  $A$  be a finite set and call it an alphabet. A word is an element of the set

$$A^* = \{a_0 a_1 \cdots a_{n-1} \mid a_i \in A, n \geq 0\}$$

and  $A^*$  is called the language of  $A$ . A language  $L$  on  $A$  is a subset of  $A^*$ .

Let  $A^{\mathbb{N}}$  be the set of all infinite sequences of elements in  $A$ . We define the map  $\sigma : A^{\mathbb{N}} \rightarrow A^{\mathbb{N}}$  by  $\sigma : \{a_k\}_{k \in \mathbb{N}} \mapsto \{a_{k+1}\}_{k \in \mathbb{N}}$ . A cylinder is a set of the form

$${}_k[a_k \cdots a_{k+l}]_{k+l} = \{b_0 b_1 \cdots \in A^{\mathbb{N}} \mid b_i = a_i, \forall i = k, \dots, k+l\}.$$

A subset  $S \subseteq A^{\mathbb{N}}$  is said to be a subshift if it is invariant under  $\sigma$  and closed in the topology generated by the collection of all cylinders. We say that a word  $a_0 a_1 \cdots a_{n-1} \in A^*$  is allowed if there is a sequence  $\{i_k\} \in S$  and an integer  $m \geq 0$  such that  $a_k = i_{m+k}$  for  $k = 0, 1, \dots, n-1$ . The set of allowed words is called the language of  $S$ .

In Chapter 2 we consider the special case of the Belykh maps when  $k = 0$  and  $\gamma$  and  $\lambda$  are arbitrary. In this case the dynamics depends only on the second coordinate and we therefore study the dynamics of the projection to the second coordinate. The map  $T : [-(\gamma - 1), (\gamma - 1)] \rightarrow [-(\gamma - 1), (\gamma - 1)]$  is then the following.

$$T(x) = \begin{cases} \gamma x - (\gamma - 1) & \text{if } x > 0, \\ \gamma x + (\gamma - 1) & \text{if } x < 0. \end{cases}$$

The graph of  $T$  is in Figure 1.2. By a change of variables  $T$  can be written in the form  $x \mapsto \gamma x + \alpha \pmod{1}$  where  $\alpha = 1 - \gamma/2$ . This is similar to the  $\beta$ -expansion,  $f_\beta : [0, 1] \rightarrow [0, 1)$ ,  $f_\beta : x \mapsto \beta x \pmod{1}$ , introduced by Rényi [28] in the context of expanding numbers in non-integer bases, see figure 1.3. The theory was further developed by Parry in [22], where he describes the associated subshift — the  $\beta$ -shift, defined below — in terms of the orbit of 1. He also proved the existence of an absolutely continuous invariant measure and calculated the topological entropy.

Let  $[x]$  denote the integer part of the number  $x$  and let  $\{x\}$  denote the fractional part of  $x$ . Let  $\beta > 1$ . For any  $x \in [0, 1]$  we associate the sequence

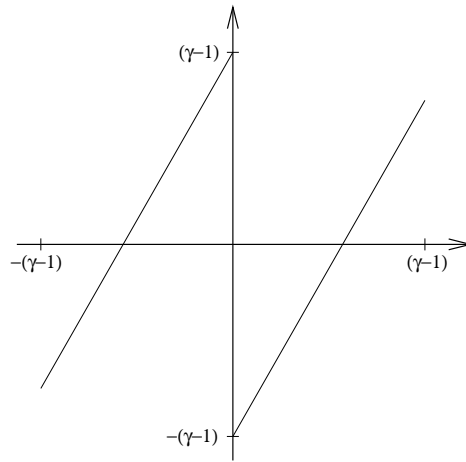

Figure 1.2: The graph of  $T$ .

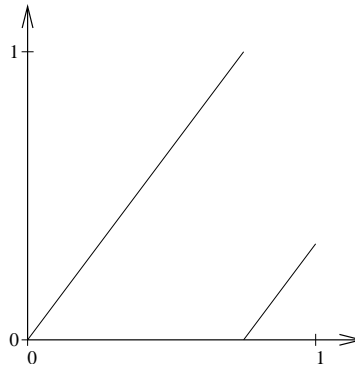

Figure 1.3: The graph of the map  $f_\beta : x \mapsto \beta x \pmod{1}$ , for  $\beta = \frac{3}{4}$ .

$d(x, \beta) \in \{0, 1, \dots, [\beta]\}^{\mathbb{N}}$  defined as follows. If  $d(x, \beta) = \{i_k\}_{k=0}^\infty$  then for each  $k \in \mathbb{N}$  we define

$$i_k = [\beta f_\beta^k(x)] = [\underbrace{\beta\{\beta\{\beta \cdots \{\beta x\}\}}}_k].$$

The closure of the set of all such sequences is denoted by  $S_\beta$  and it is called the  $\beta$ -shift. It is invariant under the left-shift  $\sigma : \{i_k\}_{k=0}^\infty \mapsto \{i_{k+1}\}_{k=0}^\infty$  and the map  $d(\cdot, \beta)$  satisfies  $\sigma^n(d(x, \beta)) = d(f_\beta^n(x), \beta)$ . If we order  $S_\beta$  with the lexico-

---

graphical ordering then the map  $d(\cdot, \beta)$  is one-to-one and monotone increasing.

Parry [22] proved that the map  $\beta \mapsto d(1, \beta)$  is monotone increasing and injective. For a sequence  $\{i_k\}_{k=0}^{\infty}$  there is a  $\beta > 0$  such that  $\{i_k\}_{k=0}^{\infty} = d(1, \beta)$  if and only if  $\sigma^n(\{i_k\}) \leq \{i_k\}$  for every  $n \geq 0$ . The number  $\beta$  is then the unique positive solution of the equation

$$1 = \sum_{k=0}^{\infty} i_k x^{-k}.$$

The subshift  $S_\beta$  is the set of sequences  $\{i_k\}$  such that  $\sigma^n(\{i_k\}) \leq d(1, \beta)$  for every  $n \geq 0$ . If  $x \in [0, 1]$  then

$$x = \sum_{k=0}^{\infty} d(x, \beta)_k \beta^{-k}.$$

Any subshift  $S$  can be classified in the following way.

**Definition 1.0.0.1.** *A subshift  $S$  is said to be a subshift of finite type, SFT, if the set of forbidden words is finite. Equivalently, a subshift is of finite type if it is associated with a finite directed graph with labelled vertices, that is there is a finite directed graph  $G$  with labelled vertices such that a sequence is in  $S$  if and only if there is a path in  $G$  which yields the same sequence by reading of the labels of the vertices along the path.*

*A subshift  $S$  is said to be sofic if it is associated with a finite directed graph with labelled edges.*

*A subshift  $S$  is said to be specified, or have the specification property, if there exists a number  $k$  such that if  $a$  and  $b$  are words in the language of  $S$  then there is a word  $c$  of length  $k$  such that the word  $acb$  is allowed.*

Note that if  $S$  is of finite type then it is sofic. There are subshifts that are not sofic and subshifts that are not specified.

It is possible to characterise the different types of subshifts  $S_\beta$  in terms of the properties of the sequence  $d(1, \beta)$  and make connections to the number-theoretical properties of  $\beta$ , see for example [7] and [31] for a collection of results on the subject. Among other results are

*$S_\beta$  is of finite type if and only if  $d(1, \beta)$  either terminates with zeros or is periodic. [22]*

*$S_\beta$  is sofic if and only if  $d(1, \beta)$  is eventually periodic, that is the orbit of 1 under  $f_\beta$  is finite. [6]*

*$S_\beta$  is specified if and only if there is an  $n$  such that there are no  $n$  consecutive zeros in  $d(1, \beta)$ . [6]*

*If  $\beta$  is a Pisot number then  $S_\beta$  is sofic. [22]*

*If  $S_\beta$  is sofic then  $\beta$  is a Perron number. [20], [9]*

The methods from the  $\beta$ -expansion can be applied to the map  $T$  with small changes. We will describe the associated subshift and give analogous results to those mentioned above for the  $\beta$ -expansion. This is done in Chapter 2.

In Chapter 3 we study a class of maps similar to the Belykh systems. We prove the existence of an absolutely continuous invariant measure and prove exponential decay of correlation for Hölder continuous function.



## Chapter 2

# Restriction to one dimension

## 2.1 Definition of the system

Put  $Q = [-1, 1]^2$  and  $S = ([-1, 0] \times \{-k\}) \cup (\{0\} \times [-|k|, |k|]) \cup ([0, 1] \times \{k\})$ . Let  $Q_1$  and  $Q_{-1}$  be the upper respectively the lower connected component of the set  $Q \setminus S$ .

Consider the class of maps  $f : Q \setminus S \rightarrow Q$  defined by

$$f(x, y) = \begin{cases} (\lambda x + (1 - \lambda), & \gamma y - (\gamma - 1)), & \text{if } (x, y) \in Q_1, \\ (\lambda x - (1 - \lambda), & \gamma y + (\gamma - 1)), & \text{if } (x, y) \in Q_{-1}, \end{cases}$$

where the parameters are  $0 < \lambda \leq 1$ ,  $-1 < k < 1$  and  $1 < \gamma \leq \frac{2}{1+|k|}$ . These are the Belykh maps.

## 2.2 The one-dimensional case

Here we consider the case  $k = 0$ . In this case the dynamics in the second coordinate do not depend on the first coordinate and the dynamics in the first coordinate are completely determined by that of the second. Hence the interesting dynamics take place in the second coordinate and we therefore study the projection of  $f$  to this coordinate. Let the map  $T : I_\gamma \rightarrow I_\gamma$ , where  $I_\gamma = [-(\gamma - 1); (\gamma - 1)]$  be defined by

$$T(x) = \begin{cases} \gamma x - (\gamma - 1) & \text{if } x > 0, \\ \gamma x + (\gamma - 1) & \text{if } x \leq 0. \end{cases}$$

We have defined  $T$  to be  $(\gamma - 1)$  at 0 for convenience, but we could just as well have defined it to be  $-(\gamma - 1)$ .

### 2.2.1 A subshift with two kneading sequences

Let  $I_{-1} = [-(\gamma - 1); 0]$  and  $I_1 = [0; (\gamma - 1)]$ . For any  $x \in I_\gamma$  we associate a sequence  $\underline{i} = \{i_k\}_{k=0}^\infty \in \{-1, 1\}^\mathbb{N}$  defined by  $T^k(x) \in I_{i_k}$  for any  $k \in \mathbb{N}$ . Then  $x$  and  $\underline{i}$  satisfy

$$x = \frac{\gamma - 1}{\gamma} \sum_{k=0}^{\infty} \frac{i_k}{\gamma^k}.$$

We let  $\Sigma_\gamma$  denote the closure of the set of all such sequences and define the map  $\pi_\gamma : \Sigma_\gamma \rightarrow I_\gamma$  by

$$\pi_\gamma(\underline{i}) = \frac{\gamma - 1}{\gamma} \sum_{k=0}^{\infty} \frac{i_k}{\gamma^k}.$$

The left-shift  $\sigma$  is defined by  $\sigma(\{i_k\}_{k=0}^{\infty}) = \{i_{k+1}\}_{k=0}^{\infty}$ . It is easy to see that  $\pi_\gamma(\sigma^n(\underline{i})) = T^n(\pi_\gamma(\underline{i}))$ . The set  $\Sigma_\gamma$  is invariant under  $\sigma$  and is hence a subshift.

We endow the subshift  $\Sigma_\gamma$  with the lexicographical ordering, denoted by  $\leq$ . Because  $T$  is piecewise monotone increasing this makes the map  $\pi_\gamma$  monotone increasing.

We denote by  $\underline{\gamma} = \{\gamma_k\}_{k=0}^{\infty} \in \Sigma_\gamma$  the sequence that satisfies  $\gamma - 1 = \pi_\gamma(\underline{\gamma})$ . If we let  $-\underline{\gamma} = \{-\gamma_k\}$  denote the sequence such that  $i_k = -\gamma_k$  for each  $k$  then  $-(\gamma - 1) = \pi_\gamma(-\underline{\gamma})$  and  $\Sigma_\gamma$  is the set

$$\Sigma_\gamma = \{\underline{i} \mid -\underline{\gamma} \leq \sigma^k(\underline{i}) \leq \underline{\gamma}, \forall k \in \mathbb{N}\}. \quad (2.1)$$

We will call  $\underline{\gamma}$  the upper kneading sequence and  $-\underline{\gamma}$  the lower kneading sequence.

Since we have defined  $T(0) = (\gamma - 1)$  there is no  $n$  such that  $\sigma^n(\underline{\gamma}) = -\underline{\gamma}$ . It is however possible that  $\sigma^n(\underline{\gamma}) = \underline{\gamma}$ . If we had defined  $T(0)$  to be  $-(\gamma - 1)$  then we would have the opposite case.

We let  $\Xi : (1, 2) \rightarrow \{-1, 1\}^{\mathbb{N}}$  denote the map that maps  $\gamma \in (1, 2)$  to the upper kneading sequence of  $\Sigma_\gamma$ . The map  $\Xi$  satisfies  $\pi_\gamma(\Xi(\gamma)) = \gamma - 1$ .

Let  $\mathcal{K}$  denote the set of kneading sequences. Define

$$\mathcal{P}_n = \{\underline{\gamma} \in \mathcal{K} \mid \underline{\gamma} = (\gamma_1 \gamma_2 \cdots \gamma_n)^\infty \text{ for some } \gamma_1 \gamma_2 \cdots \gamma_n\}$$

and let  $\mathcal{P} = \bigcup_{n=1}^{\infty} \mathcal{P}_n$ . For any  $\underline{\gamma} \in \mathcal{K}$  define

$$L(\underline{\gamma}) = \sup\{n \in \mathbb{Z} \mid \exists k : \gamma_k \gamma_{k+1} \cdots \gamma_{k+n-1} = (-\gamma_0)(-\gamma_1) \cdots (-\gamma_{n-1})\}.$$

Let

$$\mathcal{K}_n = \{\underline{\gamma} \in \mathcal{K} \mid L(\underline{\gamma}) = n\}.$$

For any word  $A = a_0 a_1 \cdots a_l$  and  $k, l \in \mathbb{N}$  we denote by  ${}_k[A]_{k+l}$  the cylinder set defined by

$$\begin{aligned} {}_k[A]_{k+l} &= \{\underline{i} \in \Sigma_\gamma \mid i_{m+k} = a_m, m = 0, 1, \dots, l\} \\ &= \bigcap_{m=k}^{k+l} \sigma^{-m}(\{\underline{i} \in \Sigma_\gamma \mid i_0 = a_k\}). \end{aligned}$$

We will use the notation  $[A] = {}_0[A]_l$ .

### 2.2.2 Classification of the subshifts

We begin by defining some different types of subshifts.

**Definition 2.2.2.1.** *A subshift is said to be of finite type, SFT, if it is associated with a finite directed graph with labelled vertices.*

*A subshift is said to be sofic if the language is associated with a finite automaton, that is a finite directed graph with labelled edges.*

*A subshift  $S$  is said to be specified, or have the specification property if there exists a number  $k$  such that if  $a$  and  $b$  are words in the language of  $S$  then there is a word  $c$  of length  $k$  such that the word  $acb$  is allowed.*

In this section we will prove the following theorem, that characterises the three types of subshifts in Definition 2.2.2.1 in terms of the kneading sequence.

**Theorem 2.2.2.1.** *The subshift  $\Sigma_\gamma$  is of finite type if and only if  $\underline{\gamma}$  is periodic.*

*The subshift  $\Sigma_\gamma$  is sofic if and only if  $\underline{\gamma}$  is eventually periodic.*

*If  $\gamma > \sqrt{2}$  then the subshift  $\Sigma_\gamma$  is specified if and only if  $\underline{\gamma} \in \mathcal{K}_n$ , for some integer  $n$ .*

This can be formulated equivalently in terms of the orbit of  $(\gamma - 1)$ .

**Theorem 2.2.2.2.** *The subshift  $\Sigma_\gamma$  is of finite type if and only if the orbit of  $(\gamma - 1)$  is periodic.*

*The subshift  $\Sigma_\gamma$  is sofic if and only if the orbit of  $(\gamma - 1)$  is finite*

*If  $\gamma > \sqrt{2}$  then the subshift  $\Sigma_\gamma$  is specified if and only if the orbit of  $(\gamma - 1)$  is bounded away from  $-(\gamma - 1)$ .*

Consider the case  $\gamma = \sqrt{2}$ . Let

$$A = \left[-\frac{\gamma-1}{\gamma+1}, \frac{\gamma-1}{\gamma+1}\right], \quad B = \left[-(\gamma-1), -\frac{\gamma-1}{\gamma+1}\right] \cup \left[\frac{\gamma-1}{\gamma+1}, (\gamma-1)\right].$$

Then  $T^{-1}(A) = B$  and  $T^{-1}(B) = A$ . Hence  $\Sigma_\gamma$  is not specified even though  $\underline{\gamma} = 11(-11)^\infty \in \mathcal{K}_1$ .

If  $\gamma < \sqrt{2}$  then  $f(A) \subset B$  and  $f(B) \subset A$  and  $\Sigma_\gamma$  can not be specified. However there is no  $\gamma \in (1, \sqrt{2})$  such that  $\underline{\gamma}$  is periodic or eventually periodic.

Let  $A$  be an alphabet and  $L \subseteq A^* = \{a_1 a_2 \cdots a_n \mid a_k \in A, n \in \mathbb{N}\}$  a language. For  $x, y \in L$  we define the relation  $\sim$  by

$$x \sim y \iff (axb \in L \text{ if and only if } ayb \in L, \forall a, b \in A^*).$$

**Definition 2.2.2.2.** *The language  $L$  is said to be rational if the quotient group with respect to the relation  $\sim$  is finite.*

The following theorem can be found in [10]. It will be used in the proof of Theorem 2.2.2.1.

**Theorem 2.2.2.3** (Kleene). *A subshift is associated with a finite automaton if and only if its language is rational.*

We can now prove Theorem 2.2.2.1.

*Proof.* We first prove that if  $\Sigma_\gamma$  is sofic then  $\sigma^n(\underline{\gamma})$  is periodic for some  $n$ .

Assume that  $\Sigma_\gamma$  is sofic and  $\sigma^n(\underline{\gamma})$  is not periodic for any  $n \in \mathbb{N}$ . Then there exists an infinite sequence  $i_1 < i_2 < \dots$  such that the sequences

$$\gamma_{i_k} \gamma_{i_k+1} \gamma_{i_k+2} \dots, \quad k = 1, 2, 3, \dots$$

are unique. Consider two sequences

$$\begin{aligned} &\gamma_{i_k} \gamma_{i_k+1} \gamma_{i_k+2} \dots, \\ &\gamma_{i_l} \gamma_{i_l+1} \gamma_{i_l+2} \dots \end{aligned}$$

Without loss of generality we may assume that there is a  $j$  such that

$$\gamma_{i_k} = \gamma_{i_l}, \dots, \gamma_{i_k+j} = \gamma_{i_l+j} \text{ and } \gamma_{i_k+j+1} > \gamma_{i_l+j+1}.$$

The sequence  $\gamma_{i_k} \gamma_{i_k+1} \gamma_{i_k+2} \dots$  prolong the word  $\gamma_0 \gamma_1 \dots \gamma_{i_k-1}$  but it does not prolong the word  $\gamma_0 \gamma_1 \dots \gamma_{i_l-1}$ . Hence the quotient group is not finite and  $\Sigma_\gamma$  is not sofic. This proves that  $\sigma^n(\underline{\gamma})$  is periodic for some  $n$  if  $\Sigma_\gamma$  is sofic.

We now prove that if  $\underline{\gamma}$  is periodic then  $\Sigma_\gamma$  is of finite type.

The subshift  $\Sigma_\gamma$  is of finite type if and only if it is associated with a finite graph with labelled vertices. Assume that  $\underline{\gamma}$  is periodic. We construct a graph in order to prove that the subshift is of finite type.

Assume that  $\underline{\gamma}$  is  $n$ -periodic. Let

$$V = \{a_0 a_1 \dots a_{n-1} \mid a_0 a_1 \dots a_{n-1} \text{ is an allowed word.}\}$$

be the set of vertices and let

$$E = \{(A, B) \mid A, B \in V, AB \text{ is an allowed word.}\}$$

be the set of edges. Then a sequence is in  $\Sigma_\gamma$  if and only if there is a corresponding path in the graph  $G = (V, E)$ . Indeed, a sequence  $\underline{a} = a_0 a_1 a_2 \dots$  is in  $\Sigma_\gamma$  if and only if the words  $a_k a_{k+1} \dots a_{k+n-1}$ ,  $k = 0, 1, \dots$  are allowed. This condition is obviously satisfied for any path in  $G$ . Furthermore, for any such sequence the words  $a_{k+nm} \dots a_{k+n(m+1)-1}$  and  $a_{k+nm} \dots a_{k+n(m+2)-1}$ ,  $k = 0, 1, \dots$ ,  $m = 0, 1, 2, \dots$  are allowed and therefore there is a corresponding path in  $G$ . An example of the construction is in Example 2.2.2.1 below.

---

## 2.2. THE ONE-DIMENSIONAL CASE

---

It is now time to prove that if  $\sigma^n(\underline{\gamma})$  is periodic for some  $n$  then  $\Sigma_\gamma$  is sofic. Assume that  $\sigma^n(\underline{\gamma})$  is periodic for some  $n$ .

If  $\underline{\gamma}$  is periodic then  $\Sigma_\gamma$  is of finite type and hence sofic. Assume that  $\underline{\gamma}$  is not periodic. Write  $\underline{\gamma} = \alpha_0\alpha_1\cdots\alpha_{m-1}(\beta_0\beta_1\cdots\beta_{n-1})^\infty = \gamma_0\gamma_1\cdots$ . We may assume that  $\alpha_0\cdots\alpha_{m-1} > \beta_0\cdots\beta_{n-1}$ .

For any finite word  $a_0\cdots a_{N-1}$  we define the state  $(k, l)$ ; Put

$$\begin{aligned} k' &= \max\{j \mid a_{N-j}\cdots a_{N-1} = \gamma_0\cdots\gamma_{j-1}\}, \\ l' &= \max\{j \mid a_{N-j}\cdots a_{N-1} = (-\gamma_0)\cdots(-\gamma_{j-1})\} \end{aligned}$$

and let

$$\begin{aligned} k &= k' && \text{if } k' \leq m+n, \\ l &= l' && \text{if } l' \leq m+n, \\ k &= m+n+r && \text{if } k' = m+pn+r, p \geq 1 \text{ and} \\ l &= m+n+r && \text{if } l' = m+pn+r, p \geq 1. \end{aligned}$$

Then  $0 \leq k, l \leq m+2n-1$ . Let  $S$  be the map  $(a_0\cdots a_{N-1}) \mapsto (k, l)$ .

Let  $V = \{(k, l) = S(A) \mid A \text{ is an allowed word.}\}$  be the set of vertices. Define the set of edges  $E$  by

$$\begin{aligned} E &= \{(k_1, l_1) \xrightarrow{L} (k_2, l_2) \mid L \in \{-1, 1\}, a_0\cdots a_{s-1}L \text{ is an allowed word with} \\ &\quad S(a_0\cdots a_{s-1}) = (k_1, l_1) \text{ and } S(a_0\cdots a_{s-1}L) = (k_2, l_2), \\ &\quad \text{where } a_0\cdots a_{s-1} = \gamma_0\cdots\gamma_{k_1-1} \text{ if } k_1 > l_1 \text{ and} \\ &\quad a_0\cdots a_{s-1} = (-\gamma_0)\cdots(-\gamma_{l_1-1}) \text{ if } l_1 > k_1\}. \end{aligned}$$

We prove that the graph  $G = (V, E)$  determines the subshift  $\Sigma_\gamma$ . Observe that the word  $A(\beta_0\cdots\beta_{n-1})B$  is allowed if and only if the words  $A(\beta_0\cdots\beta_{n-1})^i B$ ,  $i = 1, 2, 3, \dots$  are allowed. This implies that for any  $\underline{a} \in \Sigma_\gamma$  and any  $j$  the state  $S(a_0\cdots a_{j-1})$  is defined and from the vertex  $S(a_0\cdots a_{j-1})$  there is a unique edge labelled with  $a_j$  going to the vertex  $S(a_0\cdots a_j)$ . Hence the subshift determined by  $G$  contains  $\Sigma_\gamma$ .

Conversely, let  $\underline{a}$  be a sequence determined by a path in  $G$ . Then for any  $i = 1, 2, 3, \dots$  the word  $a_{i-s+1}\cdots a_i = \pm(\gamma_0\cdots\gamma_{s-1})$  where  $s = \max\{k, l\}$ ,  $(k, l) = S(a_0\cdots a_i)$ . Clearly  $a_0$  is an allowed word. Assume that  $a_0\cdots a_i$  is an allowed word. The word  $a_{i-s+1}\cdots a_i$  is allowed and by the construction of  $G$  it is clear that the word  $a_{i-s+1}\cdots a_i a_{i+1}$  is allowed. Hence  $a_0\cdots a_{i+1}$  is allowed and by induction  $\underline{a} \in \Sigma_\gamma$ .

The graph  $G$  is obviously finite so  $\Sigma_\gamma$  is indeed sofic. See Example 2.2.2.2 below for an example of the construction.

We can now prove that if  $\Sigma_\gamma$  is of finite type then  $\underline{\gamma}$  is periodic.

CHAPTER 2. RESTRICTION TO ONE DIMENSION

---

If  $\Sigma_\gamma$  is of finite type then it is sofic and  $\sigma^n(\underline{\gamma})$  is periodic for some  $n$ . Assume  $\underline{\gamma}$  is not periodic. Then we can write  $\underline{\gamma}$  as

$$\underline{\gamma} = \alpha_0 \cdots \alpha_{m-1} (\beta_0 \cdots \beta_{n-1})^\infty,$$

where  $\beta_0 \cdots \beta_{n-1} < \alpha_0 \cdots \alpha_{m-1}$ . Then there is a  $k < n$  such that  $\beta_0 \cdots \beta_{k-1} 1 > \beta_0 \cdots \beta_{n-1}$  and  $(\beta_0 \cdots \beta_{n-1})^N \beta_1 \cdots \beta_{k-1} 1$  is allowed for any  $N$ . For any  $N$  the word

$$\alpha_0 \cdots \alpha_{m-1} (\beta_0 \cdots \beta_{n-1})^N \beta_0 \cdots \beta_{k-1} 1$$

is forbidden but it contains no smaller forbidden word. Hence the subshift is not of finite type. We conclude that if  $\Sigma_\gamma$  is of finite type then  $\gamma$  is periodic.

If there is no  $n$  such that  $\underline{\gamma} \in \mathcal{K}_n$  then for any  $n$  there is an  $m$  such that

$$[\gamma_0 \cdots \gamma_m] = [\gamma_0 \cdots \gamma_m (-\gamma_1) (-\gamma_2) \cdots (-\gamma_n)].$$

This implies that  $\Sigma_\gamma$  can not be specified.

If  $\underline{\gamma} \in \mathcal{K}_n$  then for any allowed word  $C$  of length  $m$  there are  $k, l$  with  $k + l < n$  such that either

$$\begin{aligned} C \gamma_l \gamma_{l+1} \cdots \gamma_{k+l} (-11)^\infty, \\ C \gamma_l \gamma_{l+1} \cdots \gamma_{k+l} 1 (-\underline{\gamma}) \end{aligned}$$

or

$$\begin{aligned} C \gamma_l \gamma_{l+1} \cdots \gamma_{k+l} (1-1)^\infty, \\ C \gamma_l \gamma_{l+1} \cdots \gamma_{k+l} - 1 \underline{\gamma} \end{aligned}$$

are sequences in  $\Sigma_\gamma$ . Hence we have either

$$f^{m+k+1}(\pi_\gamma([C])) \supset \left[0, \frac{\gamma-1}{\gamma+1}\right], \text{ or } f^{m+k+1}(\pi_\gamma([C])) \supset \left[-\frac{\gamma-1}{\gamma+1}, 0\right].$$

For  $\gamma > \sqrt{2}$  there is an  $N$ , depending on  $\gamma$ , such that

$$f^N \left( \left[0, \frac{\gamma-1}{\gamma+1}\right] \right) = f^N \left( \left[-\frac{\gamma-1}{\gamma+1}, 0\right] \right) = [-(\gamma-1), (\gamma-1)].$$

This implies that  $\Sigma_\gamma$  is specified. □

**Example 2.2.2.1.** Let  $\underline{\gamma} = (11-1)^\infty$ . The corresponding graph is in figure 2.1. If we let  $1 = 11-1$ ,  $\bar{2} = 1-11$ ,  $3 = 1-1-1$ ,  $4 = -1-11$ ,  $5 = -11-1$  and

$6 = -111$  then we get the following adjacency matrix.

$$\begin{bmatrix} 1 & 1 & 1 & 0 & 1 & 1 \\ 0 & 1 & 1 & 1 & 1 & 1 \\ 1 & 1 & 1 & 0 & 0 & 0 \\ 0 & 1 & 0 & 1 & 1 & 1 \\ 1 & 1 & 0 & 0 & 1 & 1 \\ 0 & 0 & 1 & 1 & 1 & 1 \end{bmatrix}$$

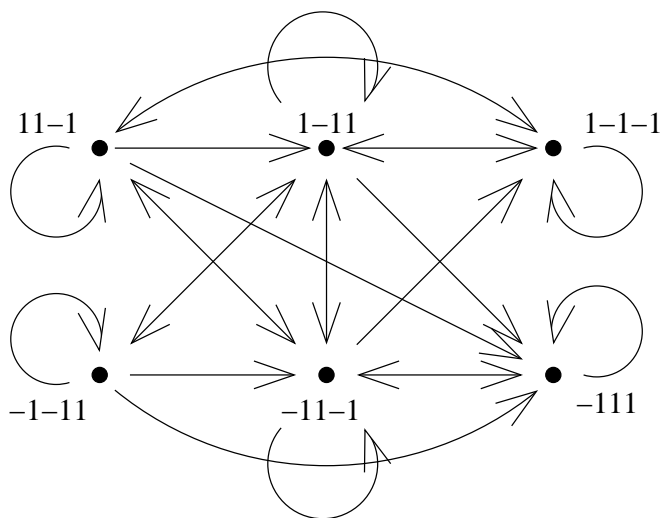

Figure 2.1: The graph associated with the subshift determined by the kneading sequence  $\underline{\gamma} = (11-1)^\infty$ .

**Example 2.2.2.2.** Let  $\underline{\gamma} = 1(1-1)^\infty$ . The corresponding graph, constructed as in the proof of theorem 2.2.2.1, is in figure 2.2. The graph for the subshift determined by  $\underline{\gamma} = 11(-11-111-11)^\infty$  is in figure 2.3.

### 2.2.3 Invariant measures

In this section we construct an absolutely continuous invariant measure. The method follows that applied for the  $\beta$ -expansion by Parry in [22]. We estimate the number of allowed words of length  $n$  in the subshift  $\Sigma_\gamma$  and use this estimate to estimate the Lebesgue measure of pre-images of any cylinder. In this way

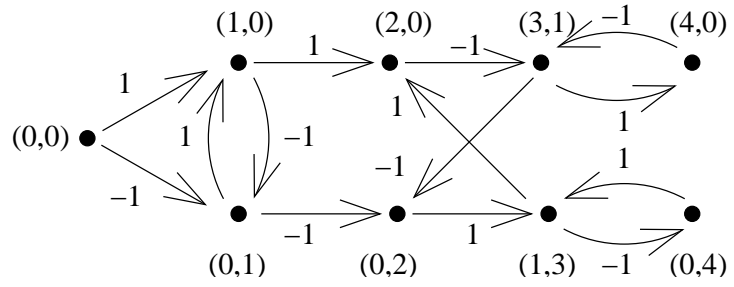

Figure 2.2: The graph associated with the subshift determined by the kneading sequence  $\underline{\gamma} = 1(1-1)^\infty$ .

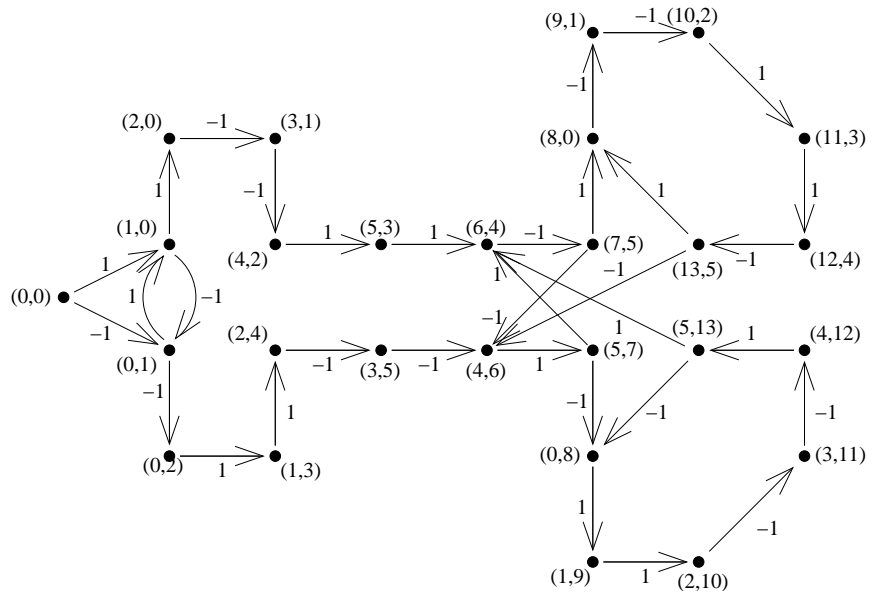

Figure 2.3: The graph associated with the subshift determined by the kneading sequence  $\underline{\gamma} = 11(-11-111-11)^\infty$ .

we can construct the absolutely continuous invariant measure as a weak limit



point of the sequence

$$\frac{1}{n} \sum_{k=0}^{n-1} \nu \circ T^{-k},$$

where  $\nu$  denotes the Lebesgue measure. The limit measure is the measure of maximal entropy.

By constructing a Markov partition Hofbauer showed in [13] that a class of piecewise monotone increasing maps of an interval has at most finitely many measures of maximal entropy and if the map is transitive then there is a unique measure of maximal entropy. Hofbauer used this method for more general maps in [14, 15, 16, 17].

Define the following metrics.

$$d_{\Sigma_\gamma}(\underline{a}, \underline{b}) = \max \left\{ \frac{1}{\gamma^n} \mid a_n \neq b_n \right\}, \quad \underline{a}, \underline{b} \in \Sigma_\gamma,$$

$$d_\gamma(\underline{a}, \underline{b}) = \left| \frac{\gamma-1}{\gamma} \sum_{k=0}^{\infty} \frac{a_k - b_k}{\gamma^k} \right|, \quad \underline{a}, \underline{b} \in \Sigma_\gamma.$$

The metric  $d_\gamma$  is the Lebesgue metric in the sense that it satisfies  $d_\gamma(\underline{a}, \underline{b}) = |\pi_\gamma(\underline{a}) - \pi_\gamma(\underline{b})|$ .

**Theorem 2.2.3.1.** *Let  $\underline{a}, \underline{b} \in \Sigma_\gamma$ . Then  $2d_{\Sigma_\gamma}(\underline{a}, \underline{b}) \geq d_\gamma(\underline{a}, \underline{b})$ .*

*Proof.* Assume that  $d_{\Sigma_\gamma}(\underline{a}, \underline{b}) = \gamma^{-n}$ . Then

$$d_\gamma(\underline{a}, \underline{b}) = \left| \frac{\gamma-1}{\gamma} \sum_{k=0}^{\infty} \frac{a_k - b_k}{\gamma^k} \right| \leq \frac{\gamma-1}{\gamma^{n+1}} \sum_{k=0}^{\infty} \frac{2}{\gamma^k} = \frac{2}{\gamma^n} = 2d_{\Sigma_\gamma}(\underline{a}, \underline{b}). \quad \square$$

The following lemma is obvious.

**Lemma 2.2.3.1.** *For any cylinder  $[C]$  of length  $m$  we have*

$$d_{\Sigma_\gamma}([C]) \leq \gamma^{-m-1},$$

$$d_\gamma([C]) \leq (\gamma-1)\gamma^{-m+1}.$$

**Lemma 2.2.3.2.** *Let  $\underline{\gamma} \in \mathcal{K}_n$ . Then for any cylinder  $[C]$  of length  $m$  we have  $d_{\Sigma_\gamma}([C]) \geq \gamma^{-n-m-1}$ .*

*Proof.* Let  $j > 0$  be such that there is no  $\underline{a}, \underline{b} \in [C]$  with  $d_{\Sigma_\gamma}(\underline{a}, \underline{b}) \geq \gamma^{-m-j}$ . There are numbers  $k$  and  $l$  such that the last  $k$  letters of  $C$  are  $\gamma_0 \cdots \gamma_{k-1}$  and the last  $l$  letters of  $C$  are  $(-\gamma_0) \cdots (-\gamma_{l-1})$ . Since  $\underline{\gamma} \in \mathcal{K}_n$  any  $\underline{a} \in [C]$  has the property that one of these chains of  $\gamma_0 \cdots \gamma_{k-1}$  and  $(-\gamma_0) \cdots (-\gamma_{l-1})$  in  $\underline{a}$  ends after at least  $n$  letters. This implies that we can find  $\underline{a}, \underline{b} \in [C]$  with  $d(\underline{a}, \underline{b}) \geq \gamma^{-m-n-1}$ .  $\square$

**Theorem 2.2.3.2.** *Assume that  $\underline{\gamma} \in \mathcal{K}_n$ . Then for any cylinder  $[C]$  such that  $d_{\Sigma_\gamma}([C]) > 0$  we have*

$$\gamma^{-n+1} \frac{\gamma-1}{\gamma+1} \leq \frac{d_\gamma([C])}{d_{\Sigma_\gamma}([C])} \leq 2.$$

*Proof.* By theorem 2.2.3.1 we have that  $\frac{d_\gamma([C])}{d_{\Sigma_\gamma}([C])} \leq 2$ .

Arguing as in the proof of Lemma 2.2.3.2 we see that there are integers  $k$  and  $l$  with  $k \leq n-1$  such that either

$$\begin{aligned} \underline{a}_0 &= C\gamma l \gamma_{l+1} \cdots \gamma_{l+k} \underline{1\gamma}, \\ \underline{a}_1 &= C\gamma l \gamma_{l+1} \cdots \gamma_{l+k} (-11)^\infty, \end{aligned}$$

or

$$\begin{aligned} \underline{a}_0 &= C\gamma l \gamma_{l+1} \cdots \gamma_{l+k} 1(-\underline{\gamma}), \\ \underline{a}_1 &= C\gamma l \gamma_{l+1} \cdots \gamma_{l+k} (1-1)^\infty. \end{aligned}$$

are in  $[C]$ . If  $m$  is the length of  $C$  then a direct calculation gives  $d_\gamma([C]) \geq \gamma^{-m-n} \frac{\gamma-1}{\gamma+1}$  and hence

$$\frac{d_\gamma([C])}{d_{\Sigma_\gamma}([C])} \geq \gamma^{-n+1} \frac{\gamma-1}{\gamma+1}. \quad \square$$

**Theorem 2.2.3.3.** *Let  $N(k)$  denote the number of allowed words of length  $k$ . Then*

$$\frac{2}{\gamma} \gamma^k \leq N(k) \leq \frac{4}{\gamma-1} \gamma^k.$$

*Proof.* There are  $N(k+1) - N(k)$  allowed words  $W$  of length  $k$  such that both  $W1$  and  $W-1$  are allowed. For each such word  $W-1\underline{\gamma}, W1-\underline{\gamma} \in \Sigma_\gamma$ . Since  $\pi_\gamma(W-1\underline{\gamma}) = \pi_\gamma(W1-\underline{\gamma})$  we may think of the word  $W$  as if it was a sequence, such that  $\pi_\gamma(W) = \pi_\gamma(W1-\underline{\gamma})$ .

Order these  $N(k+1) - N(k)$  words lexicographically and consider three consecutive words  $W_1, W_2, W_3$ . It can happen that  $W_1$  and  $W_2$  or  $W_2$  and  $W_3$  are very close. However  $d_\gamma(W_1, W_3) \geq \frac{\gamma-1}{\gamma^k}$ . Hence

$$\frac{N(k+1) - N(k)}{2} \frac{\gamma-1}{\gamma^k} \leq 2(\gamma-1)$$

and

$$N(k) \leq \frac{4}{\gamma-1} \gamma^k.$$

---

## 2.2. THE ONE-DIMENSIONAL CASE

---

Consider the allowed word  $i_0 i_1 \cdots i_{k-1}$  of length  $k$ . The cylinder  $[i_0 \cdots i_{k-1}]$  has the property that  $d_\gamma([i_0 \cdots i_{k-1}]) \leq \frac{\gamma(\gamma-1)}{\gamma^k}$ . Hence

$$N(k) \frac{\gamma(\gamma-1)}{\gamma^k} \geq 2(\gamma-1).$$

This implies that

$$N(k) \geq \frac{2}{\gamma} \gamma^k. \quad \square$$

**Corollary 2.2.3.1.** *The topological entropy of  $\Sigma_\gamma$  is  $\log \gamma$ .*

**Corollary 2.2.3.2.** *The map  $\Xi : (1, 2) \rightarrow \{-1, 1\}^{\mathbb{N}}$  is monotone increasing and injective.*

*Proof.* If  $\underline{\gamma} < \underline{\delta}$  then  $\Sigma_\gamma \subset \Sigma_\delta$  by (2.1). This implies that  $h_{\text{top}}(\Sigma_\gamma) \leq h_{\text{top}}(\Sigma_\delta)$  and so we must have  $\gamma \leq \delta$ .  $\square$

**Theorem 2.2.3.4.** *Let  $I \subseteq I_\gamma$  be any interval. Then for any  $m$*

$$\frac{1}{m} \sum_{k=0}^{m-1} \nu(T^{-k}(I)) \leq \frac{4}{\gamma-1} \nu(I),$$

where  $\nu$  denotes the Lebesgue measure. If  $\underline{\gamma} \in \mathcal{K}_n$  and  $\gamma > \sqrt{2}$  then there exists a constant  $c > 0$ , depending on  $\gamma$ , such that

$$\frac{1}{m} \sum_{k=0}^{m-1} \nu(T^{-k}(I)) \geq c \nu(I).$$

*Proof.* The set  $T^{-k}(I)$  consists of at most  $N(k)$  disjoint interval each of measure less or equal to  $\frac{\nu(I)}{\gamma^k}$ . This implies that

$$\nu(T^{-k}(I)) \leq N(k) \frac{\nu(I)}{\gamma^k} \leq \frac{4}{\gamma-1} \nu(I)$$

and hence

$$\frac{1}{m} \sum_{k=0}^{m-1} \nu(T^{-k}(I)) \leq \frac{4}{\gamma-1} \nu(I).$$

Assume that  $\underline{\gamma} \in \mathcal{K}_n$  and  $\gamma > \sqrt{2}$ . Then  $\Sigma_\gamma$  is specific and there exists an  $N$  such that for any allowed word  $i_0 i_1 \cdots i_{n-1}$  there exists a word  $W$  of length  $N$  such that  $i_0 i_1 \cdots i_{n-1} WC$  is an allowed word. So  $T^{-k}(\pi_\gamma([C]))$  consists of at least  $N(k - N)$  intervals and by Lemma 2.2.3.2 and Theorem 2.2.3.2 there

exists a constant  $c_0 > 0$  such that each of these intervals has length not less than  $c_0\nu(\pi_\gamma([C]))\gamma^{-k}$ . Hence

$$\nu(T^{-k}(\pi_\gamma([C]))) \geq N(k - N)c_0\nu(\pi_\gamma([C]))\gamma^{-k} \geq c\nu(\pi_\gamma([C])),$$

where  $c$  depends on  $\gamma$  but not on  $[C]$ . This implies the statement of the Theorem.  $\square$

**Corollary 2.2.3.3.** *There exists an invariant measure  $\mu$ , absolutely continuous with respect to the Lebesgue measure  $\nu$  such that*

$$\mu(A) = \lim_{n \rightarrow \infty} \frac{1}{n} \sum_{k=0}^{n-1} \nu(T^{-k}(A)) \leq \frac{4}{\gamma - 1} \nu(A).$$

If  $\underline{\gamma} \in \mathcal{K}_n$  and  $\gamma > \sqrt{2}$  then  $\mu$  is equivalent to  $\nu$ .

Parry [25] has shown that the measure  $\mu$  has the density

$$h(x) = D \sum_{n=0}^{\infty} (\chi_{[-(\gamma-1), T^n(\gamma-1)]}(x) - \chi_{[-(\gamma-1), T^n(-(\gamma-1))]}(x)),$$

where  $D$  is a normalising constant, and if  $\gamma > \sqrt{2}$  then  $h(x) > D \frac{\gamma^2 - 2}{\gamma(\gamma - 1)}$ .

**Theorem 2.2.3.5.** *The measure  $\mu$  is the measure of maximal entropy. That is  $h_\mu(T) = h_{\text{top}}(T)$ .*

*Proof.* It suffices to show that  $h_\mu(T) \geq \log \gamma$  since  $h_\mu(T) \leq h_{\text{top}}(T)$  for any measure and  $h_{\text{top}}(T) = \log \gamma$ . Theorem 2.2.3.4 and Lemma 2.2.3.1 implies that for any cylinder  $[C]$  of length  $n$  we have  $\mu([C]) \leq 4\gamma^{1-n}$ . If  $\mathcal{C}_n$  is the partition of  $I_\gamma$  into cylinders of length  $n$  we have

$$\begin{aligned} \frac{1}{n} \sum_{[C] \in \mathcal{C}_n} -\mu([C]) \log \mu([C]) &\geq \frac{1}{n} \sum_{[C] \in \mathcal{C}_n} \mu([C]) (n \log \gamma - \log(4\gamma)) \\ &= \log \gamma - \frac{1}{n} \log(4\gamma) \rightarrow \log \gamma, \end{aligned}$$

as  $n \rightarrow \infty$ . This shows that  $h_\mu(T) \geq \log \gamma$ .  $\square$

**Example 2.2.3.1.** If  $\Sigma_\gamma$  is specified then there exists a sequence  $\underline{a} \in \Sigma_\gamma$  such that  $\{\sigma^n(\underline{a})\}_{n \in \mathbb{N}}$  is dense in  $\Sigma_\gamma$  with respect to the metric  $d_\gamma$ .

Let  $\{\underline{a}_n\}_{n \in \mathbb{N}} = \{a_{n,1}a_{n,2} \cdots\}_{n \in \mathbb{N}}$  be dense in  $\Sigma_\gamma$ . Define

$$A_n = a_{n,1}a_{n,2} \cdots a_{n,n}.$$

The cylinder sets  $[A_n]$  are all non-empty since  $\underline{a}_n \in [A_n]$ . Since  $\Sigma_\gamma$  has finite memory there exists words  $A_{T,n}$  of length  $T_n \leq T$  such that

$$\underline{b} = A_1 A_{T,1} A_2 A_{T,2} A_3 \cdots \in \Sigma_\gamma.$$

Let

$$k_n = \sum_{i=1}^n (i + T_i).$$

Then by Lemma 2.2.3.1 and Theorem 2.2.3.2 the set  $\{\sigma^{k_n}(\underline{b})\}_{n \in \mathbb{N}}$  is dense in  $\Sigma_\gamma$  with respect to  $d_\gamma$ .

### 2.2.4 Ergodic properties

The theory of piecewise monotone maps of an interval is well developed. We use this theory to conclude that the measure  $\mu$  constructed in the previous section is the unique measure of maximal entropy and that it is Bernoulli.

**Theorem 2.2.4.1.** *Let  $\gamma > \sqrt{2}$ . If  $\gamma \in \mathcal{K}_N$  then  $T$  is mixing.*

*Proof.* Bowen [8] has shown that any piecewise  $C^2$  function on an interval with one discontinuity and derivative larger than  $\sqrt{2}$  is weakly mixing. If  $T$  is weakly mixing then  $T$  is mixing if and only if there exists a constant  $K$  such that

$$\limsup_{n \rightarrow \infty} \nu(A \cap T^{-n}B) \leq K\nu(A)\nu(B),$$

for any measurable sets  $A, B$ .

Take any two cylinders  $[A]$  and  $[B]$ . We prove that

$$d_\gamma([A] \cap T^{-n}[B]) \leq K d_\gamma([A]) d_\gamma([B]), \quad (2.2)$$

for  $n$  large enough. Let  $n_A$  be the length of the word  $A$ . Assume that  $d_{\Sigma_\gamma}([A]) = \gamma^{-N_A}$  and  $d_{\Sigma_\gamma}([B]) = \gamma^{-N_B}$ .

Let  $n > n_A$ . Then

$$[A] \cap T^{-n}[B] = \{\underline{a} \in \Sigma_\gamma \mid \underline{a} = \underbrace{A \cdots}_{n \text{ letters}} B \cdots\} = \bigcup_k [C_k],$$

where  $[C_k]$  are disjoint cylinders of the form  $[A i_{n_A} \cdots i_{j-1} B]$ . There are at most  $N(n - n_A)$  such non-empty cylinders.

By Lemma 2.2.3.2 we have  $d_{\Sigma_\gamma}([A]) \geq \gamma^{-n_A - N - 1}$ . We get

$$\begin{aligned} d_{\Sigma_\gamma}([A] \cap T^{-n}[B]) &= \sum_k d_{\Sigma_\gamma}([C_k]) \leq N(n - n_A) \gamma^{-n - N_B} \\ &\leq \frac{4}{\gamma - 1} \gamma^{n - n_A} \gamma^{-n - N_B} \leq c_1 d_{\Sigma_\gamma}([A]) d_{\Sigma_\gamma}([B]). \end{aligned}$$

By Theorem 2.2.3.2

$$\begin{aligned} d_\gamma([A] \cap T^{-n}[B]) &\leq 2d_{\Sigma_\gamma}([A] \cap T^{-n}[B]) \\ &\leq 2c_1 d_{\Sigma_\gamma}([A])d_{\Sigma_\gamma}([B]) \leq c_2 d_\gamma([A])d_\gamma([B]). \end{aligned}$$

Hence  $T$  is mixing.  $\square$

**Theorem 2.2.4.2.** *If  $\gamma > \sqrt{2}$  then  $T$  is topologically mixing.*

*Proof.* We show that for any non-empty cylinders  $[A]$  there exists a number  $n$  such that  $\sigma^n([A]) = \Sigma_\gamma$ . It then follows that  $T$  is topologically mixing.

Let  $n_A$  be the length of the word  $A$ . Let  $n_\gamma$  be the largest number such that  $(-\gamma_0) \cdots (-\gamma_{n_\gamma-1})$  is a word in  $\gamma_0 \cdots \gamma_{n_A-1}$ . Clearly,  $n_\gamma < n_A$ . There exists  $k, l < n_\gamma$  such that either

$$\begin{aligned} A\gamma_l \cdots \gamma_{l+k-1}(1-1)^\infty &\in \Sigma_\gamma, \\ A\gamma_l \cdots \gamma_{l+k-1}1(-\gamma) &\in \Sigma_\gamma, \end{aligned}$$

or

$$\begin{aligned} A\gamma_l \cdots \gamma_{l+k-1}(-11)^\infty &\in \Sigma_\gamma, \\ A\gamma_l \cdots \gamma_{l+k-1}-1\gamma &\in \Sigma_\gamma. \end{aligned}$$

Hence  $f^{n_A+k}(\pi_\gamma([A])) \supset [0, \frac{\gamma-1}{\gamma+1}]$  or  $f^{n_A+k}(\pi_\gamma([A])) \supset [-\frac{\gamma-1}{\gamma+1}, 0]$ . For any  $\gamma > \sqrt{2}$  there is a number  $N$  such that

$$f^N\left(\left[-\frac{\gamma-1}{\gamma+1}, 0\right]\right) = f^N\left(\left[0, \frac{\gamma-1}{\gamma+1}\right]\right) = [-(\gamma-1), (\gamma-1)].$$

This implies that  $T$  is topologically mixing.  $\square$

**Corollary 2.2.4.1.** *If  $\gamma > \sqrt{2}$  then the measure  $\mu$  is the unique measure of maximal entropy.*

*Proof.* In [13], Hofbauer showed that provided  $T$  is transitive then there is a unique measure of maximal entropy.  $\square$

**Theorem 2.2.4.3.**  *$T$  is ergodic with respect to the measure  $\mu$ .*

*Proof.* In [19] it is shown that that any transformation of a certain class of transformations with  $n$  discontinuities has at most  $n$  ergodic measures each absolutely continuous. Thus  $\mu$  is ergodic.  $\square$

**Theorem 2.2.4.4.** *If  $\gamma > \sqrt{2}$  then  $\mu$  is Bernoulli.*

*Proof.* Bowen [8] has shown that provided  $T$  is weakly mixing, the measure  $\mu$  is Bernoulli. As mentioned in the proof of Theorem 2.2.4.1,  $T$  is weakly mixing.  $\square$

### 2.2.5 Connection to algebraic numbers

Let  $x$  be a number. We denote by  $\mathbb{Q}[x]$  the smallest field extension of  $\mathbb{Q}$  containing the number  $x$ . A number  $x$  is called an algebraic number if it is a root of a polynomial with integer coefficients, that is there are integers  $a_0, \dots, a_n$  such that  $x$  satisfies

$$a_n x^n + a_{n-1} x^{n-1} + \dots + a_0 = 0. \quad (2.3)$$

A minimal polynomial of an algebraic number is a polynomial with integer coefficients with the least degree  $n$  such that (2.3) holds. The roots of a minimal polynomial are called the conjugates of  $x$ . If  $x$  has a minimal polynomial with  $a_n = 1$  then  $x$  is called an algebraic integer.

**Definition 2.2.5.1.** *A Salem number is an algebraic integer  $x$  of which all conjugates have modulus less than or equal to 1 and there is at least one conjugate with modulus 1.*

*A Pisot number is an algebraic integer  $x$  of which all conjugates have modulus less than 1.*

In this section we will prove the following theorem. We denote by  $\text{Per}(\gamma)$  the set of points in  $I_\gamma$  with finite orbit.

**Theorem 2.2.5.1.** *If  $\Sigma_\gamma$  is sofic then  $\gamma$  is an algebraic number of which all conjugates have modulus less than 2.*

*If  $\gamma$  is an algebraic integer then  $\text{Per}(\gamma) \subset \mathbb{Q}[\gamma]$ .*

*If  $\mathbb{Q} \cap I_\gamma \subseteq \text{Per}(\gamma)$  and  $\gamma \geq \sqrt{2}$  then  $\gamma$  is either a Pisot or a Salem number.*

*If  $\gamma$  is a Pisot number then  $\text{Per}(\gamma) = \mathbb{Q} \cap I_\gamma$ .*

For the  $\beta$ -expansion, similar results with similar proofs can be found in [22] and [34].

Let  $U$  be the set of  $\underline{\gamma}$  of the form  $\underline{\gamma} = \alpha_0 \alpha_1 \dots \alpha_{m-1} (\beta_0 \beta_1 \dots \beta_{n-1})^\infty$ . If  $\gamma \in (1, 2)$  and  $\underline{\gamma}$  is the corresponding kneading sequence then  $\gamma$  solves the equation  $(z - 1) = \pi_z(\underline{\gamma})$ . For  $\underline{\gamma} \in U$  this yields the equation

$$\begin{aligned} z^{m+n} - (\alpha_0 z^{m+n-1} + \dots + \alpha_{m-1} z^n + \beta_0 z^{n-1} + \dots + \beta_{n-1}) \\ = z^m - (\alpha_0 z^{m-1} + \dots + \alpha_{m-1}). \end{aligned} \quad (2.4)$$

We call this the characteristic equation of  $\gamma$ .

**Lemma 2.2.5.1.** *The conjugates of  $\gamma$  with respect to the characteristic equation satisfies*

$$\begin{aligned} T^0(\gamma - 1)z^{m+n-1} + T^1(\gamma - 1)z^{m+n-2} + \dots + T^{m+n-1}(\gamma - 1) \\ = T^0(\gamma - 1)z^{m-1} + T^1(\gamma - 1)z^{m-2} + \dots + T^{m-1}(\gamma - 1). \end{aligned}$$

*Proof.* Insert  $\gamma_k = -\frac{T^{k+1}(\gamma-1) - \gamma T^k(\gamma-1)}{T^0(\gamma-1)}$  into (2.4). One get

$$\begin{aligned} & T^0(\gamma-1)(z-\gamma)z^{m+n-1} + T^1(\gamma-1)(z-\gamma)z^{m+n-2} + \dots \\ & \quad + T^{m+n-1}(\gamma-1)(z-\gamma) + T^{m+n}(\gamma-1) \\ & = T^0(\gamma-1)(z-\gamma)z^{m-1} + T^1(\gamma-1)(z-\gamma)z^{m-2} + \dots \\ & \quad + T^{m-1}(\gamma-1)(z-\gamma) + T^m(\gamma-1). \end{aligned}$$

Since  $T^{m+n}(\gamma-1) = T^m(\gamma-1)$  and  $z \neq \gamma$  for the conjugates this gives the statement in the lemma.  $\square$

We are ready to prove the first statement of Theorem 2.2.5.1.

**Theorem 2.2.5.2.** *If  $\underline{\gamma} \in U$  then for any conjugate  $z$  of  $\gamma$  with respect to the characteristic equation we have  $|z| < 2$ .*

*Proof.* By Lemma 2.2.5.1 the conjugates satisfy

$$T^0(\gamma-1)z^{m+n-1} + \dots + T^{m+n-1}(\gamma-1) = T^0(\gamma-1)z^{m-1} + \dots + T^{m-1}(\gamma-1).$$

Assume  $|z| > 1$ . Then

$$\begin{aligned} & (|z|^n - 1)|z^{m-1}T^0(\gamma-1) + T(\gamma-1)z^{m-2} + \dots + T^{m-1}(\gamma-1)| \\ & < |(z^n - 1)(z^{m-1}T^0(\gamma-1) + T(\gamma-1)z^{m-2} + \dots + T^{m-1}(\gamma-1))| \\ & = |T^m(\gamma-1)z^{n-1} + \dots + T^{n+m-1}(\gamma-1)| \\ & < (\gamma-1)(|z|^{n-1} + |z|^{n-2} + \dots + 1) = (\gamma-1)\frac{|z|^n - 1}{|z| - 1}. \end{aligned}$$

Hence  $|z^{m-1}T^0(\gamma-1) + T(\gamma-1)z^{m-2} + \dots + T^{m-1}(\gamma-1)| < \frac{\gamma-1}{|z|-1}$ . Finally

$$\begin{aligned} (\gamma-1)|z|^{m-1} & < \frac{\gamma-1}{|z|-1} + |T(\gamma-1)z^{m-2} + \dots + T^{m-1}(\gamma-1)| \\ & \leq \frac{\gamma-1}{|z|-1} + (\gamma-1)\frac{|z|^{m-1} - 1}{|z|-1} = (\gamma-1)\frac{|z|^{m-1}}{|z|-1} \end{aligned}$$

implies that  $|z| < 2$ .  $\square$

Let  $\gamma$  be an algebraic integer. There exists a minimal polynomial

$$P(z) = \sum_{k=0}^{d-1} a_k z^k + z^d$$



---

## 2.2. THE ONE-DIMENSIONAL CASE

such that  $P(\gamma) = 0$ . Since  $P(\gamma) = 0$  any  $\alpha \in \mathbb{Q}[\gamma]$  can be written in the form

$$\alpha = \frac{1}{q} \sum_{k=0}^{d-1} p_k \gamma^k, \quad q, p_k \in \mathbb{Z}. \quad (2.5)$$

Because of the minimality of  $P(z)$ , this representation is unique if we choose the smallest possible  $q > 0$ .

**Lemma 2.2.5.2.** *If  $\gamma$  is an algebraic integer then  $\text{Per}(\gamma) \subseteq \mathbb{Q}[\gamma] \cap I_\gamma$ .*

*Proof.* Let  $\alpha \in \text{Per}(\gamma)$ . That is  $\underline{\alpha} = \alpha_0 \cdots \alpha_{m-1} (\alpha_m \cdots \alpha_{m+n-1})^\infty$  for some positive integers  $m$  and  $n$ . Then

$$\begin{aligned} \alpha &= \pi_\gamma(\underline{\alpha}) = \frac{\gamma-1}{\gamma} \sum_{k=0}^{\infty} \frac{\alpha_k}{\gamma^k} \\ &= \frac{\gamma-1}{\gamma^m} \sum_{k=0}^{m-1} \alpha_k \gamma^{m-k} + \frac{\gamma-1}{\gamma} \sum_{i=0}^{\infty} \sum_{k=0}^{n-1} \frac{\alpha_{m+k+in}}{\gamma^{m+k+in}} \\ &= \frac{\gamma-1}{\gamma^m} \left( \sum_{k=0}^{m-1} \alpha_k \gamma^{m-k} + \frac{1}{\gamma^n-1} \sum_{k=0}^{n-1} \alpha_{k+n} \gamma^{n-1-k} \right) \in \mathbb{Q}[\gamma]. \quad \square \end{aligned}$$

**Lemma 2.2.5.3.** *Let  $\alpha \in \mathbb{Q} \subseteq \mathbb{Q}[\gamma]$  and let  $\alpha = \frac{1}{q} \sum_{k=0}^{d-1} p_k \gamma^k$  be the unique representation of  $\alpha$  in the form (2.5). Then for any  $\delta$ ,*

$$\alpha = \frac{1}{q} \sum_{k=0}^{d-1} p_k \delta^k.$$

*Proof.* Since  $\alpha \in \mathbb{Q}$  we have  $p_k = 0$  for  $k > 0$ . □

**Lemma 2.2.5.4.** *Let  $\alpha = \frac{1}{q} \sum_{k=0}^{d-1} p_k \gamma^k \in \mathbb{Q}[\gamma]$ . Then, for any  $n$ , there exists a unique vector  $(r_{n,1}, \dots, r_{n,d}) \in \mathbb{Z}^d$  such that*

$$T_\gamma^n(\alpha) = \frac{1}{q} \sum_{k=1}^d r_{n,k} \gamma^{-k}. \quad (2.6)$$

*Proof.* From  $P(\gamma) = \sum_{k=0}^{d-1} a_k \gamma^k + \gamma^d$  we get the relations

$$\begin{aligned} \gamma^{d-1} &= - \sum_{k=0}^{d-1} a_k \gamma^{k-1}, \\ &\vdots \\ 1 &= - \sum_{k=0}^{d-1} a_k \gamma^{k-d}. \end{aligned}$$

With these relations  $\alpha$  can be written in the form  $\alpha = \frac{1}{q} \sum_{k=1}^d r_{0,k} \gamma^{-k}$ .

For any  $n$

$$T_\gamma^n(\alpha) = \gamma^n \left( \alpha - \frac{\gamma-1}{\gamma} \sum_{k=0}^{n-1} \alpha_k \gamma^{-k} \right),$$

$$T_\gamma^{n+1}(\alpha) = \gamma T_\gamma^n(\alpha) - (\gamma-1)\alpha_n.$$

Assume that  $T_\gamma^n(\alpha)$  has the representation

$$T_\gamma^n(\alpha) = \frac{1}{q} \sum_{k=1}^d r_{n,k} \gamma^{-k}.$$

Then

$$T_\gamma^{n+1}(\alpha) = \frac{1}{q} \sum_{k=1}^d r_{n,k} \gamma^{-k+1} - (\gamma-1)\alpha_n$$

$$= \frac{1}{q} \sum_{k=1}^{d-1} r_{n,k+1} \gamma^{-k} + \frac{1}{q} r_{n,1} - (\gamma-1)\alpha_n.$$

With  $P(\gamma) = 0$  this can be written in the form  $T_\gamma^{n+1}(\alpha) = \frac{1}{q} \sum_{k=1}^d r_{n+1,k} \gamma^{-k}$ .

To prove the uniqueness, assume that there exists  $(b_{n,1}, \dots, b_{n,d}) \in \mathbb{Z}^d$  such that  $T_\gamma^n(\alpha) = \frac{1}{q} \sum_{k=0}^{d-1} b_{n,k} \gamma^k$ . Then

$$\gamma^{d-1} \sum_{k=0}^{d-1} b_{n,k} \gamma^{-k} = \gamma^{d-1} \sum_{k=0}^{d-1} r_{n,k} \gamma^{-k}.$$

Because of the minimality of  $P(z)$  we must have  $b_{n,k} = r_{n,k}$ . □

**Lemma 2.2.5.5.** *Let  $\alpha \in \text{Per}(\gamma)$ . If  $\delta$  is a conjugate of  $\gamma$  then*

$$\delta^n \left( \frac{1}{q} \sum_{k=0}^{d-1} p_k \delta^k - \frac{\delta-1}{\delta} \sum_{k=0}^{n-1} \frac{\alpha_k}{\delta^k} \right) = \frac{1}{q} \sum_{k=1}^d r_{n,k} \delta^{-k} \quad (2.7)$$

*holds for any  $n \in \mathbb{N}$ . Furthermore, if  $|\delta| > 1$ , then*

$$\frac{1}{q} \sum_{k=0}^{d-1} p_k \delta^k = \frac{\delta-1}{\delta} \sum_{k=0}^{\infty} \frac{\alpha_k}{\delta^k}.$$

*Proof.* Since

$$\gamma^n \left( \alpha - \frac{\gamma-1}{\gamma} \sum_{k=0}^{n-1} \alpha_k \gamma^{-k} \right) = T_\gamma^n(\alpha) = \frac{1}{q} \sum_{k=1}^d r_{n,k} \gamma^{-k},$$

$\gamma$  solves the equation

$$z^n \left( \frac{1}{q} \sum_{k=0}^{d-1} p_k z^k - \frac{z-1}{z} \sum_{k=0}^{n-1} \frac{\alpha_k}{z^k} \right) = \frac{1}{q} \sum_{k=1}^d r_{n,k} z^{-k} \quad (2.8)$$

and so does any conjugate  $\delta$  of  $\gamma$ .

Suppose that  $|\delta| > 1$ . The set

$$\{(r_{n,1}, \dots, r_{n,d}) \mid n \in \mathbb{N}\}$$

is finite since  $\alpha \in \text{Per}(\gamma)$ . Let  $c = \sup\{|r_{n,k}| |\delta|^{-k} \mid n \in \mathbb{N}, 1 \leq k \leq d\}$ . By (2.8)

$$|\delta|^n \left| \frac{1}{q} \sum_{k=0}^{d-1} p_k \delta^k - \frac{\delta-1}{\delta} \sum_{k=0}^{n-1} \frac{\alpha_k}{\delta^k} \right| < \frac{cd}{q}.$$

Let  $n \rightarrow \infty$ . If  $|\delta| > 1$  this yields

$$\frac{1}{q} \sum_{k=0}^{d-1} p_k \delta^k = \frac{\delta-1}{\delta} \sum_{k=0}^{\infty} \frac{\alpha_k}{\delta^k}. \quad \square$$

**Theorem 2.2.5.3.** *If  $\mathbb{Q} \cap I_\gamma \subseteq \text{Per}(\gamma)$  and  $\gamma \geq \sqrt{2}$  then  $\gamma$  is either a Pisot or a Salem number.*

*Proof.* Let  $\delta$  be a root of  $P(z) = 0$  with  $|\delta| > 1$ . We prove that  $\delta = \gamma$ . This implies that  $\gamma$  is either a Pisot or a Salem number.

Let

$$h = 2 \left| \frac{\gamma-1}{\gamma} - \frac{\delta-1}{\delta} \right|, \quad \eta = \max \left\{ \frac{1}{\gamma}, \frac{1}{|\delta|} \right\}, \quad C = \frac{|\gamma-1|}{|\gamma|} + \frac{|\delta-1|}{|\delta|}.$$

Choose  $m$  such that  $\eta^m \leq \frac{1}{6} \frac{1-\eta}{\eta} \frac{h}{C}$ .

Take  $\alpha, \beta \in \mathbb{Q}$  such that

$$\begin{aligned} \underline{\alpha} &= 1(1-1)^m \alpha_{m+1} \alpha_{m+2} \cdots, \\ \underline{\beta} &= 1(-11)^m \beta_{m+1} \beta_{m+2} \cdots. \end{aligned}$$

This is possible if  $\gamma \geq \sqrt{2}$ . By Lemma 2.2.5.3 and 2.2.5.5

$$\alpha = \frac{\gamma - 1}{\gamma} \sum_{k=0}^{\infty} \frac{\alpha_k}{\gamma^k} = \frac{1}{q} \sum_{k=0}^{d-1} p_k \delta^k = \frac{\delta - 1}{\delta} \sum_{k=0}^{\infty} \frac{\alpha_k}{\delta^k}. \quad (2.9)$$

Similarly

$$\frac{\gamma - 1}{\gamma} \sum_{k=0}^{\infty} \frac{\beta_k}{\gamma^k} = \frac{\delta - 1}{\delta} \sum_{k=0}^{\infty} \frac{\beta_k}{\delta^k}. \quad (2.10)$$

(2.9) and (2.10) together imply

$$\frac{\gamma - 1}{\gamma} \left( 2 + \sum_{k=m+1}^{\infty} \frac{\alpha_k + \beta_k}{\gamma^k} \right) = \frac{\delta - 1}{\delta} \left( 2 + \sum_{k=m+1}^{\infty} \frac{\alpha_k + \beta_k}{\delta^k} \right).$$

This implies that

$$\begin{aligned} h = 2 \left| \frac{\gamma - 1}{\gamma} - \frac{\delta - 1}{\delta} \right| &\leq \sum_{k=m+1}^{\infty} 2 \left( \left| \frac{\gamma - 1}{\gamma} \right| + \left| \frac{\delta - 1}{\delta} \right| \right) \left( \left| \frac{1}{\gamma^k} \right| + \left| \frac{1}{\delta^k} \right| \right) \\ &\leq 4C \sum_{k=m+1}^{\infty} \eta^k = 4C \frac{\eta^{m+1}}{1 - \eta} \leq \frac{2}{3}h. \end{aligned}$$

Hence  $h = 0$  and  $\gamma = \delta$ .  $\square$

**Lemma 2.2.5.6.** *Let  $\gamma = \delta_1, \delta_2, \dots, \delta_d$  be the roots of  $P(z)$ . For  $\alpha \in \mathbb{Q}[\gamma]$  let  $r_{n,k}$  be defined by (2.6). For every  $n$  let*

$$t_{n,i} = \frac{1}{q} \sum_{k=1}^d r_{n,k} \delta_i^{-k}.$$

*Then  $\alpha \in \text{Per}(\gamma)$  if and only if  $\sup\{|t_{n,i}| \mid n \in \mathbb{N}, 1 \leq i \leq d\} < \infty$ .*

*Proof.* Assume  $\alpha \in \text{Per}(\gamma)$ . It is clear that  $\sup\{|r_{n,k}| \mid n \in \mathbb{N}, 1 \leq k \leq d\}$  is finite since  $\{r_{n,k}\}$  is a finite set. Hence  $\sup\{|t_{n,i}| \mid n \in \mathbb{N}, 1 \leq i \leq d\}$  is also finite.

Assume that  $\sup\{|t_{n,i}| \mid n \in \mathbb{N}, 1 \leq i \leq d\} < \infty$ . Since

$$\begin{bmatrix} t_{n,1} \\ \vdots \\ t_{n,d} \end{bmatrix} = \frac{1}{q} \begin{bmatrix} \delta_1^{-1} & \cdots & \delta_1^{-d} \\ \vdots & \ddots & \vdots \\ \delta_d^{-1} & \cdots & \delta_d^{-d} \end{bmatrix} \begin{bmatrix} r_{n,1} \\ \vdots \\ r_{n,d} \end{bmatrix}$$

and the non-singularity of the square matrix we have that  $\{r_{n,k}\}$  is bounded. Since  $r_{n,k} \in \mathbb{Z}$  the set  $\{(r_{n,1}, \dots, r_{n,d})\}$  is finite. Hence there are numbers  $N, M$  such that  $r_{N+M,k} = r_{N,k}$  for any  $1 \leq k \leq d$ . It then follows that  $\alpha \in \text{Per}(\gamma)$ .  $\square$

**Theorem 2.2.5.4.** *If  $\gamma$  is a Pisot number then  $\text{Per}(\gamma) = \mathbb{Q}[\gamma] \cap I_\gamma$ .*

*Proof.* By Lemma 2.2.5.2  $\text{Per}(\gamma) \subseteq \mathbb{Q}[\gamma] \cap I_\gamma$ .

Take  $\alpha \in \mathbb{Q}[\gamma] \cap I_\gamma$  and let  $t_{n,i}$  be defined as in Lemma 2.2.5.6. By (2.7)

$$|t_{n,i}| \leq \frac{1}{q} \sum_{k=0}^{d-1} p_k |\delta_i|^{n+k} + |\delta_i - 1| \sum_{k=1}^n |\delta_i|^k$$

Since  $|\delta_i| < 1$  for  $i \geq 2$  it follows that  $t_{n,i}$  is bounded for  $i \geq 2$ . By the definition  $t_{n,1} = T^n(\alpha)$  is also bounded. Lemma 2.2.5.6 implies that  $\alpha \in \text{Per}(\gamma)$ .  $\square$

### 2.2.6 Distance to the singularity and return times

Pesin developed in [27] the theory of a class of piecewise hyperbolic maps with singularities. The difficulties with this sort of systems lie in the presence of the singularities. A curve in the unstable direction is uniformly stretched by the map but can also be cut into pieces by the singularities. This can give the result that the curve is mapped into small pieces that do not increase in length. This phenomenon destroys the local unstable manifolds.

To handle these difficulties Pesin worked with the sets

$$\begin{aligned} &\{x \mid d(f^n(x), S) > c\lambda^{-n}, \forall n \geq 0\}, \\ &\{x \mid d(f^{-n}(x), S) > c\lambda^{-n}, \forall n \geq 0\}, \end{aligned}$$

where  $f$  is the map,  $S$  is the singularities and  $\lambda$  is the stretch rate. If a point  $x$  lies in these sets then this guarantees the existence of a local stable and unstable manifold of at least length  $c$ . It is thus of interest to estimate the measure of these sets. In this section we show that for the map  $T_\gamma$  the measures of the complement of these sets decrease exponentially with  $c$ .

In [38] Young considered a class of systems with some partial hyperbolicity. She showed that if there is a positive measure set  $\Lambda$  with sufficiently good hyperbolic properties and with exponential decay of the return time, i.e. the measure of the set

$$\{x \in \Lambda \mid n = \min\{k > 0 \mid f^k(x) \in \Lambda\}\}$$

decays exponentially with  $n$ , then this implies the existence of an SBR-measure and exponential decay of correlations for Hölder continuous functions. We show in this section that for the map  $T_\gamma$  the above mentioned sets have this property. This could be used to show exponential decay of correlations, but for this map it is easier to show this with help of Fourier series. This is done in section 2.2.7.

For each  $m \in \mathbb{N}$  and  $\alpha > 0$  define the sets

$$\begin{aligned}\Lambda_{m,\alpha}^+ &= \{\underline{x} \mid \inf_{n \geq 0} \gamma^{\alpha n} d_{\Sigma_\gamma}(\sigma^n \underline{x}, \underline{\gamma}) > \gamma^{-m}\}, \\ M_{m,\alpha}^+ &= \{\underline{x} \mid \inf_{n \geq 0} \gamma^{\alpha n} d_{\Sigma_\gamma}(\sigma^n \underline{x}, \underline{\gamma}) \leq \gamma^{-m}\}.\end{aligned}$$

Note that

$$\Lambda_{m,\alpha}^+ \subseteq \Lambda_{m+1,\alpha}^+, \quad (2.11a)$$

$$M_{m,\alpha}^+ \supseteq M_{m+1,\alpha}^+. \quad (2.11b)$$

Define the hit-time  $\tau_{\Lambda_{m,\alpha}^+}$  by

$$\tau_{\Lambda_{m,\alpha}^+}(\underline{x}) = \begin{cases} \min\{n \geq 1 \mid \sigma^n \underline{x} \in \Lambda_{m,\alpha}^+\} & \text{if } \{n \geq 1 \mid \sigma^n \underline{x} \in \Lambda_{m,\alpha}^+\} \neq \emptyset, \\ \infty & \text{otherwise.} \end{cases}$$

**Lemma 2.2.6.1.** *For any  $m \geq 1$ ,  $n \geq 0$  and  $\alpha > 0$ ,*

$$\begin{aligned}\mu(\sigma^{-n}(M_{m,\alpha}^+)) &\leq \frac{4\gamma^{2+\alpha}}{\gamma^\alpha - 1} \gamma^{-m}, \\ \nu(\sigma^{-n}(M_{m,\alpha}^+)) &\leq \frac{4\gamma^{2+\alpha}}{\gamma^\alpha - 1} \gamma^{-m}.\end{aligned}$$

*Proof.* Let

$$\begin{aligned}B &= \{\underline{x} \in \Sigma_\gamma \mid \inf_n \gamma^{\lceil \alpha n \rceil} d_{\Sigma_\gamma}(\sigma^n \underline{x}, \underline{\gamma}) \leq \gamma^{-m}\}, \\ B_i &= \bigcup_{k=0}^{\infty} k+i[\gamma_0 \cdots \gamma_{m+\lceil \alpha k \rceil - 1}],\end{aligned}$$

where  $\lceil x \rceil$  denotes the smallest integer not less than  $x$ . Note that  $B = B_0$ . We use that  $d_\gamma([S]) \leq \gamma(\gamma - 1)\gamma^{-m}$  for any cylinder  $[S]$  of length  $m \geq 1$  to estimate the Lebesgue measure of  $B_i$  as follows.

$$\begin{aligned}\nu(B_i) &\leq \sum_{k=0}^{\infty} \nu(k+i[\gamma_0 \cdots \gamma_{m+\lceil \alpha k \rceil - 1}]) \\ &\leq \sum_{k=0}^{\infty} N(k+i) \gamma(\gamma - 1) \gamma^{-(k+i+\lceil \alpha k \rceil+m)} \leq \sum_{k=0}^{\infty} 4\gamma^{2-\alpha k-m} \\ &= \frac{4\gamma^{2+\alpha}}{\gamma^\alpha - 1} \gamma^{-m}.\end{aligned}$$

It now follows that

$$\mu(B) = \lim_{n \rightarrow \infty} \frac{1}{n} \sum_{i=0}^n \nu(B_i) \leq \frac{4\gamma^{2+\alpha}}{\gamma^\alpha - 1} \gamma^{-m}.$$

The inclusion  $M_{m,\alpha}^+ \subset B$  yields the inequality for  $\mu$  in the theorem. The inequality for  $\nu$  follows by  $B = B_0$ .  $\square$

For each  $m \in \mathbb{N}$  and  $\alpha \geq 1$  define the sets

$$\begin{aligned} \Lambda_{m,\alpha}^- &= \{\underline{x} \mid \inf_{n \geq 1} \gamma^{\alpha n} d_{\Sigma_\gamma}(\sigma^{-n} \underline{x}, \underline{\gamma}) > \gamma^{-m}\}, \\ M_{m,\alpha}^- &= \{\underline{x} \mid \inf_{n \geq 1} \gamma^{\alpha n} d_{\Sigma_\gamma}(\sigma^{-n} \underline{x}, \underline{\gamma}) \leq \gamma^{-m}\}. \end{aligned}$$

and the hit-time

$$\tau_{\Lambda_{m,\alpha}^-}(\underline{x}) = \begin{cases} \min\{n \geq 1 \mid \sigma^n \underline{x} \in \Lambda_{m,\alpha}^-\} & \text{if } \{n \geq 1 \mid \sigma^n \underline{x} \in \Lambda_{m,\alpha}^-\} \neq \emptyset, \\ \infty & \text{otherwise.} \end{cases}$$

We can write  $M_{m,\alpha}^-$  in the form

$$M_{m,\alpha}^- = \bigcup_{n=1}^{\infty} [\gamma_n \cdots \gamma_{\lceil \alpha n \rceil + m - 1}]. \quad (2.12)$$

**Lemma 2.2.6.2.** *For any  $n \geq 0$  and  $\alpha > 1$*

$$\nu(M_{m,\alpha}^-) \leq \frac{\gamma - 1}{\gamma^{\alpha-1} - 1} \gamma^{1-m}.$$

*Proof.* This estimate follows by (2.12).

$$\begin{aligned} \nu(M_{m,\alpha}^-) &\leq \sum_{n=1}^{\infty} \nu([\gamma_n \cdots \gamma_{\lceil \alpha n \rceil + m - 1}]) \leq \sum_{n=1}^{\infty} (\gamma - 1) \gamma^{1 - (\lceil \alpha n \rceil + m - n)} \\ &\leq \sum_{n=1}^{\infty} (\gamma - 1) \gamma^{1 - (\alpha - 1)n - m} = \frac{\gamma - 1}{\gamma^{\alpha-1} - 1} \gamma^{1-m}. \end{aligned}$$

$\square$

**Lemma 2.2.6.3.** *The following inclusions hold*

$$\begin{aligned}
 \sigma^{-1}(\Lambda_{m,\alpha}^-) &\subseteq \Lambda_{m+[\alpha],\alpha}^- \\
 \sigma(M_{m,\alpha}^-) &\subseteq M_{m-[\alpha],\alpha}^- \\
 \sigma(\Lambda_{m,\alpha}^+) &\subseteq \Lambda_{m+[\alpha],\alpha}^+ \\
 \sigma^{-1}(M_{m,\alpha}^+) &\subseteq M_{m-[\alpha],\alpha}^+ \\
 \Lambda_{m,\alpha}^\pm &\subseteq \Lambda_{n,\alpha}^\pm, & m \leq n, \\
 M_{m,\alpha}^\pm &\supseteq M_{n,\alpha}^\pm, & m \leq n.
 \end{aligned}$$

*Proof.* Take  $\underline{x} \in \sigma^{-1}(\Lambda_{m,\alpha}^-)$ . Then for  $\underline{y} = \sigma \underline{x} \in \Lambda_{m,\alpha}^-$  it holds that

$$d_{\Sigma_\gamma}(\sigma^{-n} \underline{y}, \underline{\gamma}) > \gamma^{-m-\alpha n},$$

for some  $n \geq 1$ . This implies that

$$d_{\Sigma_\gamma}(\sigma^{-n} \underline{x}, \underline{\gamma}) > \gamma^{-(m+[\alpha])-\alpha n},$$

for any  $n \geq 0$ . Hence  $\underline{x} \in \Lambda_{m+[\alpha],\alpha}^-$  and so  $\sigma^{-1}(\Lambda_{m,\alpha}^-) \subseteq \Lambda_{m+[\alpha],\alpha}^-$ .

The other inclusions can be proved in a similar way.  $\square$

**Theorem 2.2.6.1.** *Given  $m \in \mathbb{N}$  and  $\alpha > 0$ , the following estimates are valid.*

$$\begin{aligned}
 \nu\{\underline{x} \in M_{m,\alpha}^+ \mid \tau_{\Lambda_{m,\alpha}^+}(\underline{x}) = n\} &\leq 4\gamma^{1-m-\alpha(n-1)}, \\
 \nu\{\underline{x} \in \Lambda_{m,\alpha}^+ \mid \tau_{\Lambda_{m,\alpha}^+}(\underline{x}) = n\} &\leq 4\gamma^{1-m-\alpha(n-2)}, & n \geq 2 \\
 \nu\{\underline{x} \in \Sigma_\gamma \mid \tau_{\Lambda_{m,\alpha}^-}(\underline{x}) = n\} &\leq \frac{\gamma-1}{\gamma^{\alpha-1}-1} \gamma^{2-m-n}, & \alpha > 1
 \end{aligned}$$

*Proof.* Let  $\underline{x} \in M_{m,\alpha}^+$ . Then there exists an  $n \geq 0$ , such that

$$\underline{x} = x_0 x_1 \cdots x_{n-1} \gamma_0 \gamma_1 \cdots \gamma_{m+[\alpha n]-1} x_{m+[\alpha n]+n} \cdots$$

If  $n > 0$ , then

$$\sigma \underline{x} = x_1 x_2 \cdots x_{n-1} \gamma_0 \gamma_1 \cdots \gamma_{m+[\alpha n]-1} x_{m+[\alpha n]+n} \cdots \in M_{m+\alpha,\alpha}^+ \subseteq M_{m,\alpha}^+.$$

This shows that that  $\sigma^k \underline{x} \in M_{m,\alpha}^+$  for  $0 \leq k \leq n$ . Hence for  $n \geq 0$

$$\{\underline{x} \in M_{m,\alpha}^+ \mid \tau_{\Lambda_{m,\alpha}^+}(\underline{x}) = n+1\} \subseteq n[\gamma_0 \gamma_1 \cdots \gamma_{m+[\alpha n]-1}]$$



and so

$$\nu\{\underline{x} \in M_{m,\alpha}^+ \mid \tau_{\Lambda_{m,\alpha}^+}(\underline{x}) = n+1\} \leq N(n)(\gamma-1)\gamma^{1-m-\lceil\alpha n\rceil-n} \leq 4\gamma^{1-m-\alpha n}.$$

Let  $\underline{x} \in \Lambda_{m,\alpha}^+$ . In order that  $\sigma\underline{x} \in M_{m,\alpha}^+$ , there must be an  $n \geq 1$  such that

$$\underline{x} = x_0 x_1 \cdots x_{n-1} \gamma_0 \gamma_1 \cdots \gamma_{m+\lceil\alpha(n-1)\rceil-1} x_{m+\lceil\alpha(n-1)\rceil+n} \cdots.$$

Then  $\sigma^k \underline{x} \in M_{m,\alpha}^+$  for  $1 \leq k \leq n$ . This implies that

$$\{\underline{x} \in \Lambda_{m,\alpha}^+ \mid \tau_{\Lambda_{m,\alpha}^+}(\underline{x}) = n+1\} \subseteq \bigcup_{j=1}^n [\gamma_0 \gamma_1 \cdots \gamma_{m+\lceil\alpha(n-1)\rceil-1}]$$

and

$$\begin{aligned} \nu\{\underline{x} \in \Lambda_{m,\alpha}^+ \mid \tau_{\Lambda_{m,\alpha}^+}(\underline{x}) = n+1\} &\leq N(n)(\gamma-1)\gamma^{1-m-n-\lceil\alpha(n-1)\rceil} \\ &\leq 4\gamma^{1-m-\alpha(n-1)}. \end{aligned}$$

Finally, for any  $n \geq 1$

$$\{\underline{x} \mid \sigma^k \underline{x} \in M_{m,\alpha}^-, 1 \leq k \leq n\} \subseteq \bigcup_{j=1}^{\infty} [\gamma_j \cdots \gamma_{\lceil\alpha j\rceil+n+m-1}] = M_{m+n,\alpha}.$$

Hence

$$\nu\{\underline{x} \in \Sigma_\gamma \mid \tau_{\Lambda_{m,\alpha}^-} = n\} \leq \nu(M_{m+n-1,\alpha}) \leq \frac{\gamma-1}{\gamma^{\alpha-1}-1} \gamma^{2-m-n}. \quad \square$$

### 2.2.7 Decay of correlations

Since  $T$  can be written in the forms  $x \mapsto \gamma x + 1 - \frac{\gamma}{2} \pmod{1}$ . It is easy to calculate the decay of correlations with help of Fourier series.

**Theorem 2.2.7.1.** *Let  $\mathcal{A}$  be the set of functions on  $I_\gamma$ , representable with Fourier series*

$$\phi(x) = \sum_{k \in \mathbb{Z}} a_k e^{i \frac{\pi}{\gamma-1} k x},$$

*with the property that  $|a_k| \leq \frac{A}{|k|^2}$  for some  $A$  depending on  $\phi$ . Then, for any  $\phi, \psi \in \mathcal{A}$  there exists a  $C$  such that*

$$\left| \int (\phi \circ T^n) \psi \, d\nu - \int \phi \, d\nu \int \psi \, d\nu \right| \leq C\gamma^{-n}$$

*holds for any  $n \in \mathbb{N}$ .*

*Proof.* Let

$$\phi(x) = \sum_{k \in \mathbb{Z}} a_k e^{i \frac{\pi}{\gamma-1} kx} \in \mathcal{A}, \quad \psi(x) = \sum_{k \in \mathbb{Z}} b_k e^{i \frac{\pi}{\gamma-1} kx} \in \mathcal{A}.$$

With a change of variables we can write  $T$  as

$$T : [0, 1) \ni x \mapsto \gamma x + \alpha \pmod{1},$$

where  $\alpha = 1 - \frac{\gamma}{2}$ . Equivalently, we may define  $T$  on the unit circle  $\mathbb{T}$ .

$$T : \mathbb{T} \ni z \mapsto e^{i2\pi\alpha} z^\gamma,$$

where  $\alpha = 1 - \frac{\gamma}{2}$ . We can then write  $\phi$  and  $\psi$  as

$$\phi(x) = \sum_{k \in \mathbb{Z}} a_k z^k, \quad \psi(x) = \sum_{k \in \mathbb{Z}} b_k z^k,$$

with different  $a_k$  and  $b_k$  but with the property that  $|a_k| \leq A/k^2$  and  $|b_k| \leq B/k^2$ . We can now rewrite  $\int (\psi \circ T^n) \psi d\nu$  as follows.

$$\begin{aligned} \int (\phi \circ T^n) \psi d\nu &= \int \sum_{k, l \in \mathbb{Z}} a_k b_l e^{i2\pi\alpha\gamma \frac{\gamma^n-1}{\gamma-1} z^{k\gamma^n+l}} d\nu \\ &= \sum_{k, l \in \mathbb{Z}} \int_0^1 a_k b_l e^{i2\pi\alpha\gamma \frac{\gamma^n-1}{\gamma-1} t} e^{i2\pi(\gamma^n k+l)t} dt. \end{aligned}$$

Assume that  $\gamma$  is irrational. Then

$$\int (\phi \circ T^n) \psi d\nu = \sum_{\substack{k, l \in \mathbb{Z} \\ k \neq 0}} a_k b_l e^{i2\pi\alpha\gamma \frac{\gamma^n-1}{\gamma-1} t} \frac{e^{i2\pi(\gamma^n k+l)t} - 1}{i2\pi(\gamma^n k+l)} + a_0 b_0.$$

This gives the following estimate of the correlations.

$$\begin{aligned} \left| \int (\phi \circ T^n) \psi d\nu - \int \phi d\nu \int \psi d\nu \right| &\leq \sum_{\substack{k, l \in \mathbb{Z} \\ k \neq 0}} |a_k| |b_l| \left| \frac{\sin(\pi(\gamma^n k+l))}{\pi(\gamma^n k+l)} \right| \\ &\leq \sum_{\substack{k, l \in \mathbb{Z} \\ k \neq 0, |l| \leq \frac{1}{2}\gamma^n}} |a_k| |b_l| \frac{1}{|\pi(\gamma^n k+l)|} + \sum_{\substack{k, l \in \mathbb{Z} \\ k \neq 0, |l| > \frac{1}{2}\gamma^n}} |a_k| |b_l|. \end{aligned}$$

The first sum is estimated by

$$\sum_{\substack{k, l \in \mathbb{Z} \\ k \neq 0, |l| \leq \frac{1}{2}\gamma^n}} |a_k| |b_l| \left| \frac{\sin(\pi(\gamma^n k+l))}{\pi(\gamma^n k+l)} \right| \leq \frac{2}{\pi\gamma^n} \sum_{k, l \in \mathbb{Z}} |a_k| |b_l|.$$

The second sum is estimated by

$$\begin{aligned} \sum_{\substack{k,l \in \mathbb{Z} \\ k \neq 0, |l| > \frac{1}{2}\gamma^n}} |a_k| |b_l| &\leq \sum_{|k| > \frac{1}{2}\gamma^n} \sum_{j \neq 0} \frac{AB}{j^2 k^2} \leq \sum_{|k| > \frac{1}{2}\gamma^n} \frac{AB}{k^2} 2 \left(1 + \int_1^\infty t^{-2} dt\right) \\ &\leq 4AB2 \int_{\frac{1}{2}\gamma^{n-1}}^\infty t^{-2} dt = \frac{16AB}{\gamma^n - 2}. \end{aligned}$$

Hence there exists a  $C$  such that

$$\left| \int (\phi \circ T^n) \psi \, d\nu - \int \phi \, d\nu \int \psi \, d\nu \right| \leq C\gamma^{-n}.$$

If  $\gamma$  is rational then

$$\int (\phi \circ T^n) \psi \, d\nu = \sum_{\substack{k,l \in \mathbb{Z} \\ \gamma^n k + l \notin \mathbb{Z}}} a_k b_l e^{i2\pi\alpha\gamma \frac{\gamma^n - 1}{\gamma - 1} \frac{e^{i2\pi(\gamma^n k + l)} - 1}{i2\pi(\gamma^n k + l)}} + \sum_{\substack{k,l \in \mathbb{Z} \\ \gamma^n k + l \neq 0}} a_k b_l.$$

The first sum is estimated by

$$\left| \sum_{\substack{k,l \in \mathbb{Z} \\ \gamma^n k + l \notin \mathbb{Z}}} a_k b_l e^{i2\pi\alpha\gamma \frac{\gamma^n - 1}{\gamma - 1} \frac{e^{i2\pi(\gamma^n k + l)} - 1}{i2\pi(\gamma^n k + l)}} \right| \leq \sum_{\substack{k,l \in \mathbb{Z} \\ k \neq 0, |l| \leq \frac{1}{2}\gamma^n}} |a_k| |b_l| \frac{1}{|\pi(\gamma^n k + l)|}$$

and the estimates of the correlations are done similarly as in the irrational case.  $\square$



## Chapter 3

# Absolutely continuous invariant measure for a class of piecewise affine hyperbolic endomorphisms

This chapter is based on the following article.

T. Persson, *Absolutely continuous invariant measure for a class of piecewise affine hyperbolic endomorphisms*, (to appear in *Discrete Contin. Dyn. Syst.*)

### Abstract

We consider a class of non invertible piecewise affine hyperbolic endomorphisms with singularities and show that for an open set of parameters there exists almost surely an absolutely continuous invariant measure. Also, exponential decay of correlations is proved for Hölder continuous functions.

## 3.1 Introduction

In [1], Alexander and Yorke considered a one parameter class of maps called the fat baker's transformations. These maps are piecewise affine maps of the square with one expanding and one contracting direction. Their results together with the result of Solomyak in [35], imply that for an open set of parameters, almost surely there is an absolutely continuous invariant measure. The fat baker's transformations are a special case of the Belykh map, introduced in [5] by Belykh. Schmeling and Troubetzkoy considered in [33] the Belykh map for a wider range of parameters. It was further investigated in [32].

In this article we consider a three parameter class of endomorphisms similar to the Belykh map. In fact, this class has a non empty intersection with the class of Belykh maps considered in [33] and [32] and it contains the fat baker's transformations. We show that there is an open set of parameters for which there is almost surely an absolutely continuous invariant measure.

Similar results in two dimensions, but in the case of expanding maps, were independently obtained by Buzzi in [3] and Tsujii in [36]. The corresponding results for arbitrary dimension are in [2] and [37].

In [38] Young introduced a method using a tower construction for proving exponential decay of correlations for a wide range of hyperbolic maps. Among other examples in the article she uses the method to prove exponential decay of correlations for a class of piecewise  $C^2$  maps in two dimensions. Buzzi and Keller proved in [4] that a class of piecewise affine and expanding maps have exponential decay of correlations. In Section 3.5 the method of Young is adopted to show exponential decay of correlations for our class of maps.

### 3.2 The class of endomorphisms

Put  $Q = [-1, 1]^2$  and  $S = ([-1, 0] \times \{-\kappa\}) \cup (\{0\} \times [-|\kappa|, |\kappa|]) \cup ([0, 1] \times \{\kappa\})$ . Let  $Q_1$  and  $Q_{-1}$  be the upper respectively the lower connected component of the set  $Q \setminus S$ .

Consider the class of maps  $f : Q \setminus S \rightarrow Q$  defined by

$$f(x, y) = \begin{cases} (\lambda x + (1 - \lambda), & \gamma y - (\gamma - 1)), & \text{if } (x, y) \in Q_1, \\ (\lambda x - (1 - \lambda), & \gamma y + (\gamma - 1)), & \text{if } (x, y) \in Q_{-1}, \end{cases}$$

where the parameters are  $\frac{1}{2} < \lambda \leq 1$ ,  $-1 < \kappa < 1$  and  $1 < \gamma \leq \frac{2}{1+|\kappa|}$ . See Figure 3.1.

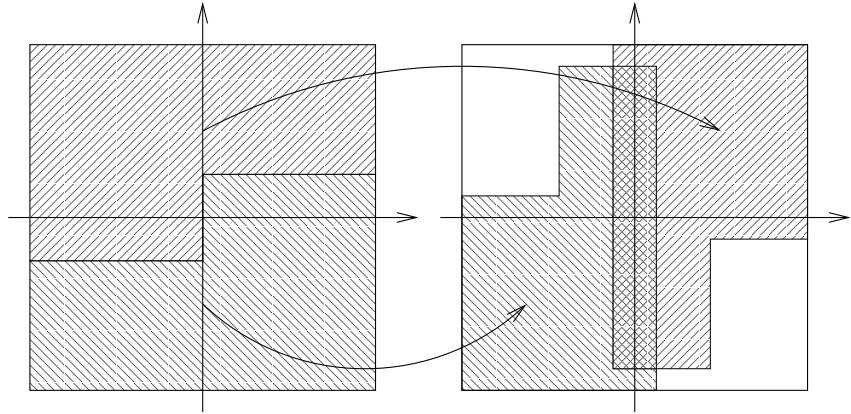

Figure 3.1: The map  $f$  for  $\gamma = \frac{3}{2}$ ,  $\lambda = \frac{9}{16}$  and  $\kappa = \frac{1}{4}$ .

The set  $S$  is the discontinuity set. Let  $S_v = \{0\} \times [-|\kappa|, |\kappa|]$  be its vertical component and  $S_h = ([-1, 0] \times \{-\kappa\}) \cup ([0, 1] \times \{\kappa\})$  be its horizontal component.

With a little more work the method of this paper can be used for maps with singularity sets with more than one jump. The only difficulty is to show that the complete backward orbit of the vertical components of the singularity consists of finitely many pieces.

The main difficulty in working with the map  $f$  is that it is not invertible. To handle this problem we lift the map  $f$  to an invertible map  $\hat{f}$  on the three dimensional cube. The idea is to prove the desired result for  $\hat{f}$  and then project the result on  $f$ . This idea has previously been used in [33] and [32].

The map  $\hat{f}$  is defined as follows. Put  $\hat{Q} = [-1, 1]^3$  and  $\hat{Q}_i = Q_i \times [-1, 1]$ ,  $i = -1, 1$ . Define  $\hat{f} : \hat{Q}_1 \cup \hat{Q}_{-1} \rightarrow \hat{Q}$  by

$$\hat{f}(x_1, x_2, x_3) = \begin{cases} (f(x_1, x_2), \tau x_3 + (1 - \tau)), & \text{if } (x_1, x_2, x_3) \in \hat{Q}_1, \\ (f(x_1, x_2), \tau x_3 - (1 - \tau)), & \text{if } (x_1, x_2, x_3) \in \hat{Q}_{-1}, \end{cases}$$

where  $\tau$  is chosen so small that  $\hat{f}$  is invertible on its image, that is  $\tau < \frac{1}{2}$ . See Figure 3.2. Denote by  $\pi$  the projection from  $\hat{Q}$  to  $Q$ , defined by  $\pi(x_1, x_2, x_3) = (x_1, x_2)$ .

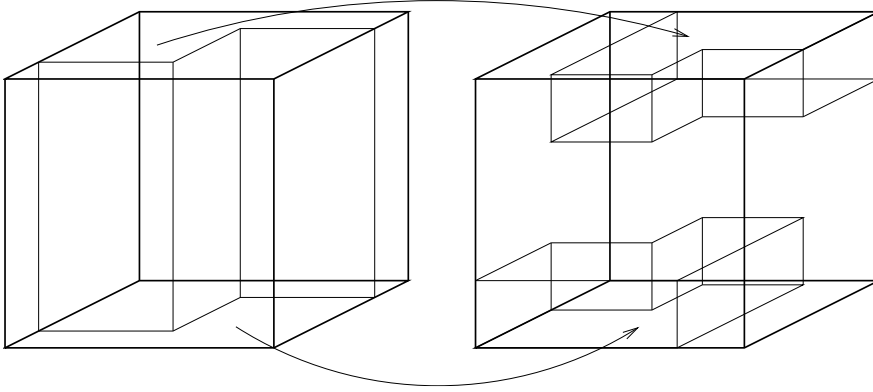

Figure 3.2: The map  $\hat{f}$  for  $\gamma = \frac{3}{2}$ ,  $\lambda = \frac{3}{4}$ ,  $\kappa = \frac{1}{4}$  and  $\tau = \frac{1}{4}$ .

Given a sequence  $\underline{i} \in \Sigma_2 = \{-1, 1\}^{\mathbb{N}}$ , define the cylinder set

$$\hat{R}_{\underline{i}}^{l,m}(\lambda, \gamma, \kappa) = \{\hat{x} \in \hat{Q} \mid \hat{f}_{\lambda, \gamma, \kappa}^n(\hat{x}) \in \hat{Q}_{i_n}, n = -m, -m+1, \dots, -l\},$$

where  $0 \leq l < m \in \mathbb{N}$ . We will write  $\hat{R}_{\underline{i}}^m(\lambda, \gamma, \kappa)$  for  $\hat{R}_{\underline{i}}^{0,m}(\lambda, \gamma, \kappa)$ . Let

$$\Sigma_{\lambda, \gamma, \kappa} = \{\underline{i} \in \Sigma_2 \mid \hat{R}_{\underline{i}}^{l,m}(\lambda, \gamma, \kappa) \neq \emptyset \forall l, m \in \mathbb{Z}\}$$

be the coding of the system  $\hat{f}_{\lambda,\gamma,\kappa}$ . Denote by  $\sigma$  the left shift.

The set

$$\hat{\Lambda}_{\lambda,\gamma,\kappa} = \bigcap_{n \in \mathbb{Z}} \hat{f}_{\lambda,\gamma,\kappa}^n(\hat{Q})$$

is the attractor of  $\hat{f}_{\lambda,\gamma,\kappa}$ . It is easy to see that the map  $\rho_{\lambda,\gamma,\kappa} : \Sigma_{\lambda,\gamma,\kappa} \rightarrow \hat{Q}$  defined by  $\rho_{\lambda,\gamma,\kappa} : \underline{i} \mapsto (x_1, x_2, x_3)$  where

$$\begin{aligned} x_1 &= \frac{1-\lambda}{\lambda} \sum_{n=1}^{\infty} i_{-n} \lambda^n, \\ x_2 &= \frac{\gamma-1}{\gamma} \sum_{n=0}^{\infty} i_n \gamma^n, \\ x_3 &= \frac{1-\tau}{\tau} \sum_{n=1}^{\infty} i_{-n} \tau^n, \end{aligned}$$

satisfies  $\rho_{\lambda,\gamma,\kappa}(\sigma(\underline{i})) = \hat{f}_{\lambda,\gamma,\kappa}(\rho_{\lambda,\gamma,\kappa}(\underline{i}))$  for all  $\underline{i} \in \Sigma_{\lambda,\gamma,\kappa}$  and  $\rho_{\lambda,\gamma,\kappa}(\Sigma_{\lambda,\gamma,\kappa}) = \hat{\Lambda}_{\lambda,\gamma,\kappa}$ . Hence  $\hat{\Lambda}_{\lambda,\gamma,\kappa}$  is the set

$$\begin{aligned} \hat{\Lambda}_{\lambda,\gamma,\kappa} = \left\{ (x_1, x_2, x_3) \mid \exists \underline{i} \in \Sigma_{\lambda,\gamma,\kappa} : x_1 = \frac{1-\lambda}{\lambda} \sum_{n=1}^{\infty} i_{-n} \lambda^n, \right. \\ \left. x_2 = \frac{\gamma-1}{\gamma} \sum_{n=0}^{\infty} i_n \gamma^n, x_3 = \frac{1-\tau}{\tau} \sum_{n=1}^{\infty} i_{-n} \tau^n \right\}. \end{aligned}$$

Let  $\hat{\nu}$  denote the normalised Lebesgue measure on  $\hat{Q}$  and for  $n \in \mathbb{N}$  define  $\hat{\nu}_n = \hat{\nu} \circ \hat{f}^{-n}$ . The sequence of measures

$$\hat{\mu}_m = \frac{1}{m} \sum_{n=0}^{m-1} \hat{\nu}_n$$

converges weakly to the SBR-measure,  $\hat{\mu}_{\text{SBR}}$ . In [33] it is shown that the measure  $\mu_{\text{SBR}} = \hat{\mu}_{\text{SBR}} \circ \pi^{-1}$  is the SBR-measure of  $f$ . It has the property that the conditional measures on the unstable manifolds are absolutely continuous with respect to Lebesgue measure.

The map  $f$  satisfies the conditions (H1), (H5)-(H9) in [27] and this implies that there exists  $C, q > 0$  such that  $\nu(f^{-n}U(S, \varepsilon)) \leq C\varepsilon^q$  for all  $n > 0$ , where  $U(S, \varepsilon)$  denotes the  $\varepsilon$ -neighborhood of  $S$ . This implies that  $\mu_{\text{SBR}}(\Lambda) = \hat{\mu}_{\text{SBR}}(\hat{\Lambda}) = 1$ . In [27] it is also shown that  $h_{\hat{\mu}_{\text{SBR}}} = h_{\mu_{\text{SBR}}} = \log \gamma$ .

Let  $x \in Q$ . We define the local stable manifold  $W^s(x)$  of  $x$  to be the largest connected subset of  $\{y \in Q \mid d(f^n(x), f^n(y)) \rightarrow 0, n \rightarrow \infty\}$  containing  $x$ . If



### 3.3. ABSOLUTELY CONTINUOUS INVARIANT MEASURE

---

the set  $\{y \in W^s(x) \mid d(x, y) < \delta\}$  is a connected curve of length  $2\delta$  then define  $W_\delta^s(x) = \{y \in W^s(x) \mid d(x, y) < \delta\}$  to be the stable manifold of  $x$  with length  $2\delta$ . Otherwise we say that  $W_\delta^s(x)$  does not exist.

Since  $f$  is not invertible we can not define the local unstable manifold of  $x$  in the usual way. Let

$$D_\delta^- = \{x \mid d(f^{-n}(x), S) > \delta\gamma^{-n} \forall n \geq 0\}.$$

This set has positive Lebesgue measure if  $\delta$  is taken sufficiently small, see [27]. It is even true that

$$\mu_{\text{SBR}}\left(\bigcup_{l=1}^{\infty} D_{l^{-1}}^-\right) = 1.$$

If  $x = (x_1, x_2) \in D_\delta^-$  then for any  $y = (y_1, y_2)$  with  $y_1 = x_1$  and  $|x_2 - y_2| < \delta$  we have  $d(f^{-n}(x), f^{-n}(y)) < \delta\gamma^{-n}$  for all  $n \geq 0$ . We can thus define the unstable manifold of  $x = (x_1, x_2) \in D_\delta^-$  of length  $\delta$  to be the set

$$W_\delta^u(x) = \{y = (y_1, y_2) \mid y_1 = x_1, |x_2 - y_2| < \delta\}.$$

If  $x \notin D_\delta^-$  then we say that  $W_\delta^u(x)$  does not exist.

### 3.3 Absolutely continuous invariant measure

We will prove the following theorem.

**Theorem 3.3.0.2.** *There is an open ball  $P \subset \{\lambda, \gamma, \kappa\}$  such that  $\mu_{\text{SBR}} \ll \nu$  for a.e.  $(\lambda, \gamma, \kappa) \in P$ .*

There are parameters in the set  $\{\gamma\lambda > 1, \kappa = 0\}$  for which the SBR-measure is not absolutely continuous. In [1], Alexander and Yorke point out that if  $\kappa = 0$ ,  $\gamma = 2$  and  $\lambda^{-1}$  is a Pisot number, then the SBR-measure is singular with respect to Lebesgue measure. If  $\gamma\lambda < 1$  then there can not be any absolutely continuous invariant measure  $\mu$ , since then the Lebesgue measure of  $f^n(Q)$  converges to zero but  $\mu(f^n(Q)) = 1$  by invariance.

### 3.4 Proof of the theorem

To prove Theorem 3.3.0.2 the method of Peres and Solomyak in [26] will be used. This is a simplified version of the method used by Solomyak in [35]. Peres and Solomyak showed the almost surely absolute continuity of a Bernoulli convolution when the associated shift space is the full two-shift  $\Sigma_2$ . In this proof we have to work with the more restricted shift space  $\Sigma_{\lambda, \gamma, \kappa}$ .

The following Lemma from [35] will be used in the proof of Theorem 3.3.0.2.

**Lemma 3.4.0.1.** *Let  $\varepsilon > 0$  be fixed and  $I \subset (\gamma^{-1} + \varepsilon, 0.64)$ . There is a constant  $c$  such that for any  $k \in \mathbb{N}$  and any  $\{a_i\}_{i=0}^\infty \in \{-1, 0, 1\}^\mathbb{N}$  the following estimate is valid.*

$$\int_I \chi_{\{|\lambda| |\lambda^k + \sum_{i=k+1}^\infty a_i \lambda^i| < r\}} \leq c(\gamma^{-1} + \varepsilon)^{-k} r.$$

Let  $\gamma, \kappa$  be fixed and  $I \subseteq (0.5, 0.64)$  any interval such that  $\{\gamma\} \times I \times \{\kappa\} \subset P$ , where the set  $P$  will be chosen later.

Let  $B_r(t) = [t - r, t + r]$  and let

$$D(\mu_{\text{SBR}}^{\lambda, s, x}, t) = \liminf_{r \rightarrow 0} \frac{\mu_{\text{SBR}}^{\lambda, s, x}(B_r(t))}{2r}$$

denote the lower derivative of the measure  $\mu_{\text{SBR}}^{\lambda, s, x}$  — the conditional measure of  $\mu_{\text{SBR}}^\lambda$  with respect to the local stable manifold  $W^s(x)$ . The partition of  $Q$  into local stable manifolds is clearly measurable so the conditional measures exist and we can use them as follows. We want to prove that for a.e.  $\lambda$  there is a set  $\Omega_\lambda$  such that  $\mu_{\text{SBR}}^\lambda(\Omega_\lambda) > 0$  and

$$\int_{\Omega_\lambda} D(\mu_{\text{SBR}}^{\lambda, s, x} |_{\Omega_\lambda}, y) d\mu_{\text{SBR}}^{\lambda, s, x}(y) < \infty \quad (3.1)$$

holds for a.e.  $x$ . This implies that the measure  $\mu_{\text{SBR}}^{\lambda, s, x}$  restricted to the set  $\Omega_\lambda$  is absolutely continuous for a.e.  $x$ . Since the conditional measures on the unstable manifolds are absolutely continuous with respect to Lebesgue measure, this implies that  $\mu_{\text{SBR}}^\lambda |_{\Omega_\lambda}$  is absolutely continuous with respect to Lebesgue measure. Since  $\mu_{\text{SBR}}^\lambda(\Omega_\lambda) > 0$ , ergodicity then implies that this also holds for the measure  $\mu_{\text{SBR}}^\lambda$ .

Fatou's lemma implies that in order to prove (3.1) it suffices to prove that

$$\liminf_{r \rightarrow 0} \frac{1}{r} \int_{\Omega_\lambda} \mu_{\text{SBR}}^{\lambda, s, x}(\Omega_\lambda \cap B_r(y)) d\mu_{\text{SBR}}^{\lambda, s, x}(y) < \infty.$$

We may rewrite this as

$$\liminf_{r \rightarrow 0} \frac{1}{r} \int_{\Omega_\lambda} \int_{\Omega_\lambda} \chi_{\{|y_1 - z_1| < r\}} d\mu_{\text{SBR}}^{\lambda, s, x}(z) d\mu_{\text{SBR}}^{\lambda, s, x}(y) < \infty. \quad (3.2)$$

We will choose a class of functions  $x : I \rightarrow Q$  such that  $x(\lambda) \in \Omega_\lambda$  and prove that the following estimate is valid

$$\liminf_{r \rightarrow 0} \frac{1}{r} \int_I \int_{\Omega_\lambda} \int_{\Omega_\lambda} \chi_{\{|y_1 - z_1| < r\}} d\mu_{\text{SBR}}^{\lambda, s, x(\lambda)}(z) d\mu_{\text{SBR}}^{\lambda, s, x(\lambda)}(y) d\lambda < \infty. \quad (3.3)$$

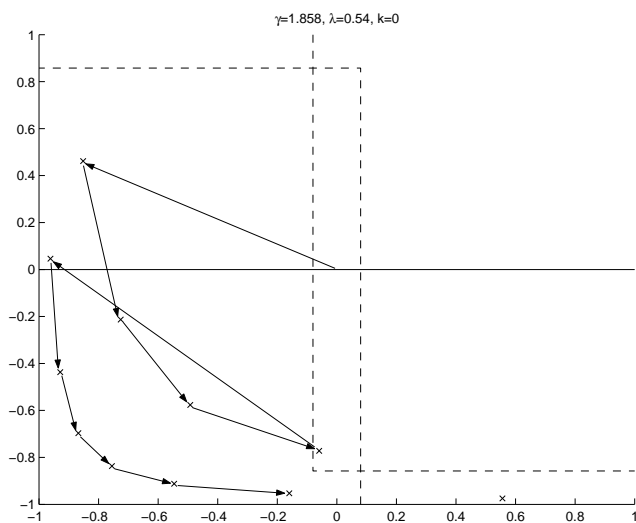
 Figure 3.3: Some inverse images of  $S_v$ .

This then implies that  $\mu_{\text{SBR}} \ll \nu$  for a.e.  $\lambda \in I$ . Instead of proving (3.3) we use that  $\mu_{\text{SBR}} = \hat{\mu}_{\text{SBR}} \circ \pi^{-1}$  and prove the equivalent condition

$$\liminf_{r \rightarrow 0} \frac{1}{r} \int_I \int_{\hat{\Omega}_\lambda} \int_{\hat{\Omega}_\lambda} \chi_{\{|y_1 - z_1| < r\}} d\hat{\mu}_{\text{SBR}}^{\lambda, s, \hat{x}(\lambda)}(\hat{z}) d\hat{\mu}_{\text{SBR}}^{\lambda, s, \hat{x}(\lambda)}(\hat{y}) d\lambda < \infty. \quad (3.4)$$

To prove (3.4) the symbolic coding  $\Sigma_{\lambda, \gamma, \kappa}$  will be used. Since we have  $\gamma$  and  $\kappa$  fixed and vary  $\lambda$  it is the dynamics taking place in the horizontal direction that is crucial. It is hence the dynamical behaviour of the vertical component of the singularity  $S_v$  that is important. Below, we will choose a set  $P$  in which  $S_v$  behaves as if it does not exist.

One checks with a numerical calculation that for  $\gamma = 1.858$ ,  $\lambda = 0.54$  and  $\kappa = 0$  there are only finitely many points in the complete backward orbit of the vertical piece of the singularity,  $S_v$ . Numerics are only used to see this in an easy way. It does not influence on the rigourousity of the proof. In this case, when  $\kappa = 0$ , we have  $S_v = \{0\}$ . Figure 3.3 and 3.4 illustrate this by showing the two possible paths of  $\{0\}$  starting in  $Q_1$ . The points in the backward orbit of  $S_v$  are marked with  $\times$  in the figures. The dashed lines are the border of the sets  $f(Q_1)$  and  $f(Q_{-1})$ . The arrows shows how the points are mapped by  $f^{-1}$ . Each path drawn in the figures terminates after finitely many steps, after which there are no more inverse images.

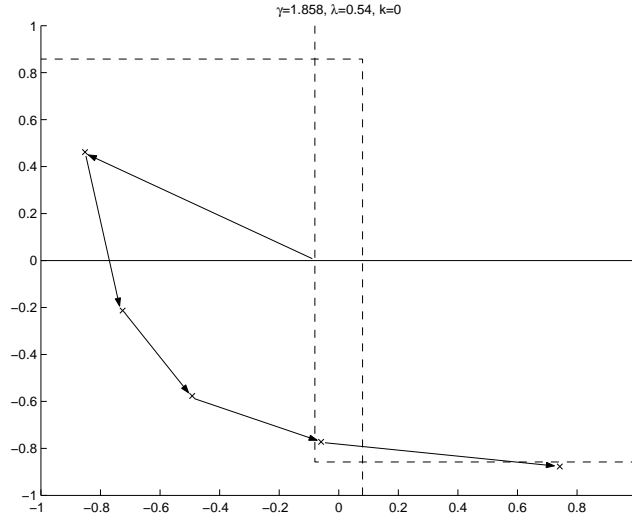

Figure 3.4: Yet some inverse images of  $S_v$ .

The numerical evaluations of the points are in Table 3.1 and Table 3.2. Comparing these values with

$$\begin{aligned} f(Q_1) &= [1 - 2\lambda, 1] \times [1 - \gamma, 1] = [-0.08, 1] \times [-0.858, 1], \\ f(Q_{-1}) &= [-1, 2\lambda - 1] \times [-1, \gamma - 1] = [-1, 0.08] \times [-1, 0.858], \end{aligned}$$

shows that there are no more points in the backward orbit of  $S_v$  and that these points are bounded away from the set  $f(S)$ . This allow us to draw the following conclusion. There is an open neighborhood  $U$  of  $S_v$  such that  $f^{-N}(U) = \emptyset$  for  $N$  sufficiently large.

By the continuous dependence on the parameters of the finitely many points in the backward orbit of  $S_v$ , there exists an open ball  $P \subset \{\gamma, \lambda, \kappa\}$  around  $(\gamma, \lambda, \kappa) = (1.858, 0.54, 0)$  such that the backward orbit of  $S_v$  behaves in the same way for any  $(\gamma, \lambda, \kappa) \in P$  in the following sense. For any  $(\gamma, \lambda, \kappa) \in P$  the backward orbit of  $S_v$  contains finitely many pieces, each bounded away from  $f(S)$ , and there are uniform numbers  $\alpha > 0$  and  $N > 0$  such that  $U = [-\alpha, \alpha] \times [-|\kappa|, |\kappa|]$  satisfies  $f^{-N}(U) = \emptyset$ . This implies that  $U \cap \Lambda_{\gamma, \lambda, \kappa} = \emptyset$  for any  $(\gamma, \lambda, \kappa) \in P$ .

Recall that we have the parameters  $\gamma$  and  $\kappa$  fixed and  $I$  is an interval such that  $\{\gamma\} \times I \times \{\kappa\} \subset P$ . Partition  $I$  into sub intervals  $\{I_t\}_{t=1}^p$ , such that  $|I_t| < \frac{1}{15}\alpha$ . This can be done so that  $p < \frac{15|I|}{\alpha} + 1$ . For each  $t = 1, \dots, p$  fix a

---

3.4. PROOF OF THE THEOREM

---

iterate	coordinates	numerical values	contained in
0	0 0	0 0	$f(Q_1) \cap f(Q_{-1})$
-1	$\frac{-1+\lambda}{\lambda}$ $\frac{-1+\gamma}{\gamma}$	-0.8519 0.4618	$f(Q_{-1}) \setminus f(Q_1)$
-2	$\frac{-1+2\lambda-\lambda^2}{\lambda^2}$ $\frac{-1+2\gamma-\gamma^2}{\gamma^2}$	-0.7257 -0.2132	$f(Q_{-1}) \setminus f(Q_1)$
-3	$\frac{-1+2\lambda-\lambda^3}{\lambda^3}$ $\frac{-1+2\gamma-\gamma^3}{\gamma^3}$	-0.4919 -0.5766	$f(Q_{-1}) \setminus f(Q_1)$
-4	$\frac{-1+2\lambda-\lambda^4}{\lambda^4}$ $\frac{-1+2\gamma-\gamma^4}{\gamma^4}$	-0.05916 -0.7721	$f(Q_1) \cap f(Q_{-1})$
-5	$\frac{-1+2\lambda-2\lambda^4+\lambda^5}{\lambda^5}$ $\frac{-1+2\gamma-2\gamma^4+\gamma^5}{\gamma^5}$	-0.9614 0.04623	$f(Q_{-1}) \setminus f(Q_1)$
-6	$\frac{-1+2\lambda-2\lambda^4+2\lambda^5-\lambda^6}{\lambda^6}$ $\frac{-1+2\gamma-2\gamma^4+2\gamma^5-\gamma^6}{\gamma^6}$	-0.9285 -0.4369	$f(Q_{-1}) \setminus f(Q_1)$
-7	$\frac{-1+2\lambda-2\lambda^4+2\lambda^5-\lambda^7}{\lambda^7}$ $\frac{-1+2\gamma-2\gamma^4+2\gamma^5-\gamma^7}{\gamma^7}$	-0.8677 -0.6969	$f(Q_{-1}) \setminus f(Q_1)$
-8	$\frac{-1+2\lambda-2\lambda^4+2\lambda^5-\lambda^8}{\lambda^8}$ $\frac{-1+2\gamma-2\gamma^4+2\gamma^5-\gamma^8}{\gamma^8}$	-0.7549 -0.8369	$f(Q_{-1}) \setminus f(Q_1)$
-9	$\frac{-1+2\lambda-2\lambda^4+2\lambda^5-\lambda^9}{\lambda^9}$ $\frac{-1+2\gamma-2\gamma^4+2\gamma^5-\gamma^9}{\gamma^9}$	-0.5462 -0.9122	$f(Q_{-1}) \setminus f(Q_1)$
-10	$\frac{-1+2\lambda-2\lambda^4+2\lambda^5-\lambda^{10}}{\lambda^{10}}$ $\frac{-1+2\gamma-2\gamma^4+2\gamma^5-\gamma^{10}}{\gamma^{10}}$	-0.1596 -0.9528	$f(Q_{-1}) \setminus f(Q_1)$
-11	$\frac{-1+2\lambda-2\lambda^4+2\lambda^5-\lambda^{11}}{\lambda^{11}}$ $\frac{-1+2\gamma-2\gamma^4+2\gamma^5-\gamma^{11}}{\gamma^{11}}$	0.5563 -0.9746	$Q \setminus (f(Q_1) \cup f(Q_{-1}))$

Table 3.1: The points in Figure 3.3.

iterate	coordinates	numerical values	contained in
0	0	0	$f(Q_1) \cap f(Q_{-1})$
-1	$\frac{-1+\lambda}{\lambda}$ $\frac{-1+\gamma}{\gamma}$	-0.8519 0.4618	$f(Q_{-1}) \setminus f(Q_1)$
-2	$\frac{-1+2\lambda-\lambda^2}{\lambda^2}$ $\frac{-1+2\gamma-\gamma^2}{\gamma^2}$	-0.7257 -0.2132	$f(Q_{-1}) \setminus f(Q_1)$
-3	$\frac{-1+2\lambda-\lambda^3}{\lambda^3}$ $\frac{-1+2\gamma-\gamma^3}{\gamma^3}$	-0.4919 -0.5766	$f(Q_{-1}) \setminus f(Q_1)$
-4	$\frac{-1+2\lambda-\lambda^4}{\lambda^4}$ $\frac{-1+2\gamma-\gamma^4}{\gamma^4}$	-0.05916 -0.7721	$f(Q_1) \cap f(Q_{-1})$
-5	$\frac{-1+2\lambda-\lambda^5}{\lambda^5}$ $\frac{-1+2\gamma-\gamma^5}{\gamma^5}$	0.7423 -0.8773	$Q \setminus (f(Q_1) \cup f(Q_{-1}))$

Table 3.2: The points in Figure 3.4.

$\lambda_t \in I_t$ . The following lemma will provide sufficient control when changing the parameter  $\lambda$ .

**Lemma 3.4.0.2.** *For any  $t$  and any  $\lambda, \lambda' \in I_t$  the symbolic spaces  $\Sigma_{\lambda, \gamma, \kappa}$  and  $\Sigma_{\lambda', \gamma, \kappa}$  coincide.*

*Proof.* A point  $\hat{x} = (x_1, x_2, x_3) \in \hat{Q}$  lies in  $\hat{\Lambda}_{\lambda_t}$  if and only if there is a sequence  $\{i_n\}_{n \in \mathbb{Z}}$  such that

$$x_1 = \frac{1 - \lambda_t}{\lambda_t} \sum_{n=1}^{\infty} i_{-n} \lambda_t^n, \quad x_2 = \frac{\gamma - 1}{\gamma} \sum_{n=0}^{\infty} i_n \gamma^{-n}, \quad x_3 = \frac{1 - \tau}{\tau} \sum_{n=1}^{\infty} i_{-n} \tau^n$$

and  $\hat{f}_{\lambda_t}^n(\hat{x}) \in \hat{Q}_{i_n}$  for all  $n \in \mathbb{Z}$ . Let  $\hat{x} = (x_1, x_2, x_3) \in \hat{\Lambda}_{\lambda_t}$ . We show that for any  $\lambda' \in I_t$  there is a point  $\hat{x}' = (x'_1, x'_2, x'_3) \in \hat{\Lambda}_{\lambda'}$  such that the corresponding sequence  $\{i'_n\}_{n \in \mathbb{Z}}$  satisfies  $i'_n = i_n$  for all  $n \in \mathbb{Z}$ . In this way we define a map  $\Xi_{\lambda_t, \lambda'} : \hat{\Lambda}_{\lambda_t} \rightarrow \hat{\Lambda}_{\lambda'}$  by  $\Xi_{\lambda_t, \lambda'} : \hat{x} \mapsto \hat{x}'$ .

It suffices to show that the point  $\hat{x}' = (x'_1, x'_2, x'_3)$  defined by

$$x'_1 = \frac{1 - \lambda'}{\lambda'} \sum_{n=1}^{\infty} i_{-n} (\lambda')^n, \quad x'_2 = \frac{\gamma - 1}{\gamma} \sum_{n=0}^{\infty} i_n \gamma^n, \quad x'_3 = \frac{1 - \tau}{\tau} \sum_{n=1}^{\infty} i_{-n} \tau^n$$

satisfies  $\hat{f}_{\lambda'}^n(\hat{x}') \in \hat{Q}_{i_n}$  for all  $n \in \mathbb{Z}$ . Then this implies that  $\hat{x}' \in \hat{\Lambda}_{\lambda'}$ . A change of  $\lambda$  has only influence on the second coordinate of  $\hat{f}(\hat{x})$ . Since the local stable

---

### 3.4. PROOF OF THE THEOREM

manifolds are parallel and oriented in the direction of the second coordinate it suffices to check that when changing  $\lambda$ , the second coordinate never move over the vertical discontinuity  $S_v$ . We do this by an estimate of the derivative  $\frac{d}{d\lambda}\left(\frac{1-\lambda}{\lambda}\sum_{n=0}^{\infty}i_{-n}\lambda^n\right)$ . A simple calculation gives that

$$\begin{aligned} \left|\frac{d}{d\lambda}\left(\frac{1-\lambda}{\lambda}\sum_{n=0}^{\infty}i_{-n}\lambda^n\right)\right| &\leq \left|\frac{1}{\lambda^2}\sum_{n=0}^{\infty}i_n\lambda^n\right| + \left|\frac{1-\lambda}{\lambda}\sum_{n=1}^{\infty}ni_n\lambda^{n-1}\right| \\ &\leq \frac{1}{\lambda^2}\sum_{n=0}^{\infty}\lambda^n + \frac{1-\lambda}{\lambda}\sum_{n=1}^{\infty}n\lambda^{n-1} = \frac{1+\lambda}{\lambda^2(1-\lambda)} < 15, \end{aligned}$$

if  $\frac{1}{2} < \lambda < \frac{3}{4}$ . This implies that

$$|x_1 - x'_1| \leq \sup_{\lambda} \left| \frac{d}{d\lambda} \left( \frac{1-\lambda}{\lambda} \sum_{n=0}^{\infty} i_{-n} \lambda^n \right) \right| |\lambda_t - \lambda'| < 15 |I_t| \leq \alpha.$$

This means that  $\hat{x}'$  does not cross the vertical piece of the singularity and hence stays on the same side of the singularity as  $\hat{x}$ . Similarly one shows that any iterate  $\hat{f}_{\lambda'}^n(\hat{x}')$  of stays on the same side of the singularity as  $\hat{f}_{\lambda_t}^n(\hat{x})$ .  $\square$

**Remark.** *The partition of  $I$  into subintervals is arbitrary so in fact the symbolic spaces coincide for any  $\lambda, \lambda' \in I$ .*

We have shown that the symbolic space  $\Sigma_{\lambda, \gamma, \kappa}$  does not change when  $\lambda$  varies. We also need to estimate how the measure  $\hat{\mu}_{\text{SBR}}^{\lambda}$  changes.

**Lemma 3.4.0.3.** *There is a constant  $c_1 > 0$  such that for any  $t$  and any  $\lambda, \lambda' \in I_t$*

$$c_1^{-1} \hat{\mu}_{\text{SBR}}^{\lambda_t}(C_{\lambda_t}) \leq \hat{\mu}_{\text{SBR}}^{\lambda}(C_{\lambda}) \leq c_1 \hat{\mu}_{\text{SBR}}^{\lambda_t}(C_{\lambda_t}), \quad (3.5)$$

for any cylinder set of the form  $C_{\lambda} = {}_k[i_k i_{k+1} \cdots i_n]_n = \bigcap_{j=k}^n \hat{f}_{\lambda}^{-j}(\hat{Q}_{i_j})$ ,  $k < n$ .

*Proof.* Since there are only finitely many inverse images of the set  $S_v$ , all other inverse images of the singularity will consist of a horizontal line. As  $\lambda$  varies over  $I$  these horizontal lines are not changed, only the inverse images of  $S_v$  changes. There is thus a constant  $c_1$ , independent of  $t$ , such that for any  $\lambda \in I_t$  and any cylinder set of the form  $C_{\lambda} = {}_k[i_k i_{k+1} \cdots i_n]_n = \bigcap_{j=k}^n \hat{f}_{\lambda}^{-j}(\hat{Q}_{i_j})$ ,  $0 \leq k < n$  we have

$$c_1^{-1} \hat{\nu}(C_{\lambda_t}) \leq \hat{\nu}(C_{\lambda}) \leq c_1 \hat{\nu}(C_{\lambda_t}).$$

Especially  $c_1^{-1} \hat{\nu}(\hat{f}_{\lambda_t}^{-m}(C_{\lambda_t})) \leq \hat{\nu}(\hat{f}_{\lambda}^{-m}(C_{\lambda})) \leq c_1 \hat{\nu}(\hat{f}_{\lambda_t}^{-m}(C_{\lambda_t}))$  for any  $m \in \mathbb{N}$  and so

$$c_1^{-1} \hat{\mu}_{\text{SBR}}^{\lambda_t}(C_{\lambda_t}) \leq \hat{\mu}_{\text{SBR}}^{\lambda}(C_{\lambda}) \leq c_1 \hat{\mu}_{\text{SBR}}^{\lambda_t}(C_{\lambda_t}),$$

for any cylinder set of the form  $C_\lambda = {}_k[i_k i_{k+1} \cdots i_n]_n = \bigcap_{j=k}^n \hat{f}_\lambda^{-j}(\hat{Q}_{i_j})$  with  $k < n$ .  $\square$

**Remark.** Lemma 3.4.0.3 is also valid for the conditional measures on the stable manifold.

Since the entropy of the conditional measures are a.s. equal that of the measure, the Shannon-McMillan-Breiman theorem implies that given  $\varepsilon > 0$ , there exists a number  $n_0(\lambda, \hat{x}, \varepsilon)$  such that

$$\hat{\mu}_{\text{SBR}}^{\lambda, s, \hat{x}} \left( \left\{ \hat{y} \mid \hat{\mu}_{\text{SBR}}^{\lambda, s, \hat{x}}(\hat{R}_\lambda^q(\hat{y})) < e^{-q \log(\gamma - \varepsilon)}, q > n_0(\lambda, \hat{x}, \varepsilon) \right\} \right) > 1 - \varepsilon.$$

Lusin's Theorem implies that there is a number  $n_1(\varepsilon)$  and a set  $\hat{\Omega}_{0, \lambda_t}$  such that  $n_1(\varepsilon) \geq n_0(\lambda_t, \hat{x}, \varepsilon)$  when  $\hat{x} \in \hat{\Omega}_{0, \lambda_t}$  and  $\hat{\mu}_{\text{SBR}}^{\lambda_t}(\hat{\Omega}_{0, \lambda_t}) > 1 - \varepsilon$ . We put

$$\hat{\Omega}_{\lambda_t} = \left\{ \hat{y} \in \hat{\Omega}_{0, \lambda_t} \cap \hat{W}^s(\hat{x}) \mid \hat{x} \in \Omega_{0, \lambda_t} \text{ and } \hat{\mu}_{\text{SBR}}^{\lambda, s, \hat{x}}(\hat{R}_\lambda^q(\hat{y})) < e^{-q \log(\gamma - \varepsilon)}, q > n_1(\varepsilon) \right\}.$$

Then  $\hat{\mu}_{\text{SBR}}^{\lambda_t}(\hat{\Omega}_{\lambda_t}) > 1 - 2\varepsilon$ .

Put  $\hat{\Omega}_\lambda = \Xi_{\lambda_t, \lambda}(\hat{\Omega}_{\lambda_t})$  for  $\lambda \in I_t$ . By Lemma 3.4.0.3 it follows that if  $\hat{y} \in \hat{\Omega}_\lambda$  then

$$\hat{\mu}_{\text{SBR}}^\lambda(\hat{R}_\lambda^q(\hat{y})) < c_1 e^{-q \log(\gamma - \varepsilon)}, q > n_1(\varepsilon)$$

and

$$\hat{\mu}_{\text{SBR}}^\lambda(\hat{\Omega}_\lambda) > c_1^{-1} \hat{\mu}_{\text{SBR}}^{\lambda_t}(\Omega_{\lambda_t}) > c_1^{-1}(1 - 2\varepsilon).$$

Take a  $\lambda_0 \in I$  and  $\hat{x}_{\lambda_0} \in \hat{\Omega}_{\lambda_0}$ . Define  $\hat{x}(\lambda_0) = \hat{x}_{\lambda_0}$  and for  $\lambda \in I$  define  $\hat{x}(\lambda)$  so that  $\rho_{\lambda, \gamma, \kappa}^{-1}(\hat{x}(\lambda)) = \rho_{\lambda_0, \gamma, \kappa}^{-1}(\hat{x}(\lambda_0))$ . Then  $\hat{x}$  is continuous. By Lemma 3.4.0.1

$$\begin{aligned} T_{\hat{z}, t, k} &= \int_{I_t} \int_{\hat{\Omega}_\lambda \cap \hat{R}_{\hat{z}}^k(\lambda)} \int_{\hat{\Omega}_\lambda \cap \hat{R}_{\hat{z}-1}^k(\lambda)} \chi_{\{|y_1 - z_1| < r\}} d\hat{\mu}_{\text{SBR}}^{\lambda, s, \hat{x}(\lambda)}(\hat{z}) d\hat{\mu}_{\text{SBR}}^{\lambda, s, \hat{x}(\lambda)}(\hat{y}) d\lambda \\ &\leq c_1^2 \int_{I_t} \int_{\hat{\Omega}_{\lambda_t} \cap \hat{R}_{\hat{z}}^k(\lambda_t)} \int_{\hat{\Omega}_{\lambda_t} \cap \hat{R}_{\hat{z}-1}^k(\lambda_t)} \chi_{\{|\Xi_{\lambda_t, \lambda}(\hat{y})_1 - \Xi_{\lambda_t, \lambda}(\hat{z})_1| < r\}} \\ &\quad d\hat{\mu}_{\text{SBR}}^{\lambda_t, s, \hat{x}(\lambda_t)}(\hat{z}) d\hat{\mu}_{\text{SBR}}^{\lambda_t, s, \hat{x}(\lambda_t)}(\hat{y}) d\lambda \\ &= c_1^2 \int_{\hat{\Omega}_{\lambda_t} \cap \hat{R}_{\hat{z}}^k(\lambda_t)} \int_{\hat{\Omega}_{\lambda_t} \cap \hat{R}_{\hat{z}-1}^k(\lambda_t)} \int_{I_p} \chi_{\{|\Xi_{\lambda_t, \lambda}(\hat{y})_1 - \Xi_{\lambda_t, \lambda}(\hat{z})_1| < r\}} \\ &\quad d\lambda d\hat{\mu}_{\text{SBR}}^{\lambda_t, s, \hat{x}(\lambda_t)}(\hat{z}) d\hat{\mu}_{\text{SBR}}^{\lambda_t, s, \hat{x}(\lambda_t)}(\hat{y}) \\ &\leq c_2(\gamma^{-1} + \varepsilon)^{-k} r \hat{\mu}_{\text{SBR}}^{\lambda_t, s, \hat{x}(\lambda_t)}(\hat{R}_{\hat{z}}^k(\lambda_t)) \hat{\mu}_{\text{SBR}}^{\lambda_t, s, \hat{x}(\lambda_t)}(\hat{R}_{\hat{z}-1}^k(\lambda_t)) \\ &\leq c_2 r (\gamma^{-1} + \varepsilon)^{-k} (\gamma - \varepsilon)^{-k} \hat{\mu}_{\text{SBR}}^{\lambda_t, s, \hat{x}(\lambda_t)}(\hat{R}_{\hat{z}}^k(\lambda_t)). \end{aligned}$$



Since

$$\hat{\Lambda}_\lambda \times \hat{\Lambda}_\lambda = \bigcup_{k=0}^{\infty} \bigcup_{\underline{i}} \hat{R}_{\underline{i}1}^k(\lambda) \times \hat{R}_{\underline{i}-1}^k(\lambda)$$

we can proceed as follows

$$\begin{aligned} & \int_I \int_{\hat{\Omega}_\lambda} \int_{\hat{\Omega}_\lambda} \chi_{\{|y_1 - z_1| < r\}} d\hat{\mu}_{\text{SBR}}^{\lambda, s, \hat{x}(\lambda)}(z) d\hat{\mu}_{\text{SBR}}^{\lambda, s, \hat{x}(\lambda)}(y) d\lambda \\ &= \sum_{t=1}^p \sum_{k=0}^{\infty} \sum_{\underline{i}} T_{\underline{i}, t, k} \\ &\leq \sum_{t=1}^p \sum_{k=0}^{\infty} \sum_{\underline{i}} c_3 r (\gamma^{-1} + \varepsilon)^{-k} (\gamma - \varepsilon)^{-k} \hat{\mu}_{\text{SBR}}^{\lambda_t, s, \hat{x}(\lambda_t)}(\hat{R}_{\underline{i}1}^k(\lambda_t)) \\ &\leq \sum_{t=1}^p \sum_{k=0}^{\infty} c_3 r (\gamma^{-1} + \varepsilon)^{-k} (\gamma - \varepsilon)^{-k} \leq \sum_{t=1}^p c_4 r = c_5 r. \end{aligned}$$

Hence

$$\liminf_{r \rightarrow 0} \frac{1}{r} \int_I \int_{\hat{\Omega}_\lambda} \int_{\hat{\Omega}_\lambda} \chi_{\{|y_1 - z_1| < r\}} d\hat{\mu}_{\text{SBR}}^{\lambda, s, \hat{x}(\lambda)}(z) d\hat{\mu}_{\text{SBR}}^{\lambda, s, \hat{x}(\lambda)}(y) d\lambda \leq c_5. \quad (3.6)$$

This is independent of the choice of  $\hat{x} : I \rightarrow Q$  so this proves Theorem 3.3.0.2.  $\square$

### 3.5 Decay of correlations

Consider the following class of Hölder continuous functions defined on  $Q$

$$\mathcal{H}_\eta = \{\phi : Q \rightarrow \mathbb{R} \mid \exists C : |\phi(x) - \phi(y)| < Cd(x, y)^\eta \forall x, y \in Q\}.$$

We will show that  $f$  has exponential decay of correlations for functions in  $\mathcal{H}_\eta$ . More precisely, we will show the following theorem.

**Theorem 3.5.0.3.** *Let  $(\lambda, \gamma, \kappa) \in P$ . There is a  $\tau = \tau(\eta) < 1$  such that if  $\phi, \psi \in \mathcal{H}_\eta$  then there is a  $C = C(\phi, \psi)$  such that*

$$\left| \int (\phi \circ f_{\lambda, \gamma, \kappa}^n) \psi d\mu_{\text{SBR}} - \int \phi d\mu_{\text{SBR}} \int \psi d\mu_{\text{SBR}} \right| < C\tau^n.$$

In [38], Young introduces a general scheme for proving exponential decay of correlations. The method is to find a set  $\Theta$  with nice hyperbolic properties

and a hyperbolic product structure;

$$\Theta = \left( \bigcup_{\omega^s \in \Gamma^s} \omega^s \right) \cap \left( \bigcup_{\omega^u \in \Gamma^u} \omega^u \right),$$

where  $\Gamma^s$  and  $\Gamma^u$  are collections of stable and unstable curves respectively, and a return time  $R : \Theta \rightarrow \mathbb{N}$  such that  $f^{R(\cdot)}(\cdot) : \Theta \rightarrow \Theta$ .

For  $\omega \in \Gamma^u$  let  $\nu_\omega$  denote the conditional measure of the Lebesgue measure  $\nu$  with respect to the curve  $\omega$ . If the conditions

$$\begin{aligned} \nu_\omega(\omega \cap \Theta) &> 0, \text{ for each } \omega \in \Gamma^u \\ \nu\{x \in \Theta \mid R(x) > n\} &< C\theta^n, \text{ for some } C \text{ and } \theta < 1, \\ (f^n, Q) &\text{ is ergodic for each } n > 0, \end{aligned}$$

and some other regularity conditions are satisfied then this is sufficient to conclude exponential decay of correlations for Hölder continuous functions.

Among other examples in [38], Young shows how to find the set  $\Theta$  and the return time  $R$  for a class of piecewise  $C^2$  hyperbolic maps in two dimensions. This class of maps is different from our class but still the method can be used to construct  $\Theta$  and  $R$ . We give the construction of  $\Theta$  and  $R$  below.

The fact that  $(\lambda, \gamma, \kappa) \in P$  makes the construction of  $\Theta$  easier. This is because there is a uniform estimate of the length of the local stable manifolds for these parameters. From Section 3.4 we conclude that  $W_\alpha^s(x)$  exists for all  $x \in \Lambda$ . Theorem 3.5.0.3 is true also if  $(\lambda, \gamma, \kappa) \notin P$  but then we have to work with the set

$$D_\delta^+ = \{x \mid d(f^n(x), S) > \delta\gamma^{-n} \forall n \geq 0\},$$

which would have made the construction of  $\Theta$  somewhat more technical.

We will now proceed with the construction of  $\Theta$  and  $R$ . It is important to gather enough expansion in the unstable direction. For this purpose we take an  $N \in \mathbb{N}$  such that  $\gamma^N > 2e^{\frac{1}{\varepsilon}}$ .

Choose  $\delta > 0$  so that for any curve  $\omega$  in the unstable direction with length not greater than  $\delta$  the set  $f^N(\omega)$  consists of at most two connected components. This can be done since we can choose  $\delta$  to be the smallest distance between the lines in the set  $\cup_{n=0}^N f^{-n}(S_h)$ .

Take  $0 < \delta_0 < \frac{1}{6}\delta$  to be so small that the set

$$A_{\delta_0} = \{x \in \Theta \mid W_{2\delta_0}^u(x) \text{ exists}\}$$

has positive Lebesgue measure. For any  $x \in A_{\delta_0}$  we define  $\Omega(x) = W_{\delta_0}^u(x)$ . Put

$$\begin{aligned} \Gamma^s(x) &= \{W^s(y) \mid y \in \Omega(x)\}, \\ \Gamma^u(x) &= \{W^u(z) \mid z \in A_{\delta_0}, W^u(z) \cap W^s \neq \emptyset, \forall W^s \in \Gamma^s(x)\}. \end{aligned}$$

We let  $\Theta(x)$  be the hyperbolic set with the product structure defined by  $\Gamma^s(x)$  and  $\Gamma^u(x)$ .

For any  $x \in A_{\delta_0}$  we let  $Q(x)$  be the smallest open rectangle containing  $\Theta(x)$ . The open sets  $\{Q(x)\}_{x \in A_{\delta_0}}$  form an open covering of  $A_{\delta_0}$ . Since  $A_{\delta_0}$  is compact we can select a finite subcover  $\{Q(x_i)\}_{i=1}^r$ . The sets  $\{\Theta(x_i)\}_{i=1}^r$  will then cover  $A_{\delta_0}$ . We will write  $\Theta_i$  for  $\Theta(x_i)$ .

We define the return time  $R$  to  $\cup \Theta_i$  on a subset of the sets  $\Theta_i$ . Let  $i$  be fixed. We iterate the map  $f^N$  and consider the connected components of the set  $(f^N)^n(\Omega(x_i))$ .

We construct for each  $n \in \mathbb{N}$  a partition  $\mathcal{P}_n^i$  of  $\Omega(x_i) \setminus \{R \leq n\}$  into connected curves with the property that if  $\omega \in \mathcal{P}_n^i$  then  $(f^N)^n(\omega)$  is a connected curve of length  $< 6\delta_0$ .

Let  $\mathcal{P}_0^i$  be the trivial partition,  $\mathcal{P}_0^i = \{\Omega(x_i)\}$ . Assume that  $\mathcal{P}_{n-1}^i$  is defined. Let  $\omega \in \mathcal{P}_{n-1}^i$ . Since  $(f^N)^{n-1}(\omega)$  is a connected curve of length  $< 6\delta_0$  the set  $(f^N)^n(\omega)$  consists of at most two connected components. Let  $\{\omega'_j\}_{j=1,2}$  be the corresponding components of  $\omega$ . If  $(f^N)^n(\omega_j)$  has length  $< 6\delta_0$  then we put  $\omega_j$  in  $\mathcal{P}_n^i$ . If however  $(f^N)^n(\omega_j)$  has length  $\geq 6\delta_0$  then there is a  $k$  such that  $(f^N)^n(\omega_j)$  crosses  $Q(x_k)$  with segments of length  $\geq \delta_0$  sticking out on each side of  $Q(x_k)$ . Since  $|(f^N)^n(\omega_j)| \geq 6\delta_0$  we have  $(f^N)^n(\omega_j) \in \Gamma^u(x_k)$  and this implies that  $(f^N)^n(\omega_j) \cap Q(x_k) \subset \Theta_k$ . We define  $R = n$  on  $\omega_j \cap (f^N)^{-n}(\Theta_k)$ . In this way we get two pieces of length  $> \delta_0$  on each side of  $(f^N)^n(\omega_j \setminus \{R = n\})$ . We partition  $\omega \setminus \{R = n\}$  into  $\{\omega_{j,k}\}_{k=1}^m$  such that  $\delta_0 < (f^N)^n(\omega_{j,k}) < 6\delta_0$  and put  $\{\omega_{j,k}\}$  in  $\mathcal{P}_n^i$ .

Finally, if  $\omega \in \mathcal{P}_{n-1}^i$  then we define  $R = n$  on the set

$$S_\omega = \left( \bigcup_{\omega^s \in \Gamma^s(\omega)} \omega^s \right) \cap \left( \bigcup_{\omega^u \in \Gamma^u} \omega^u \right) \subset \Theta_i,$$

where  $\Gamma^s(\omega)$  is the set of local stable manifolds in  $\Gamma^s(x_i)$  which has non-empty intersection with  $\omega$ . The uniform estimate on the length of  $\omega_s \in \Gamma^s$  implies that  $(f^N)^n(S_\omega) \subset \Theta_k$ .

**Lemma 3.5.0.4.** *Let  $\Omega = \Omega(x_i)$  for some  $x_i$ . There exists  $C > 0$  and  $\theta_1 < 1$  such that*

$$\nu_\Omega\{R > n\} \leq C\theta_1^n.$$

*Proof.* Let  $T_1(x)$  be the smallest  $n \geq 1$  such that if  $\omega \in \mathcal{P}_{n-1}$  is the component containing  $x$  then  $|(f^N)^n(\omega)| \geq 6\delta_0$ . If there is no such  $n$  then we say that  $T_1(x)$  is not defined. Note that  $T_1 \leq R$ .

Suppose that  $T_k(x)$  has been defined. Then we define  $T_{k+1}(x)$  to be the smallest  $n > T_k(x)$  such that if  $\omega \in \mathcal{P}_{n-1}$  is the component containing  $x$  then  $|(f^N)^n(\omega)| \geq 6\delta_0$ . Let  $\mathcal{T}_k = \{T_k \text{ is defined}\}$ .

Each time a segment is stretched to a length over  $6\delta_0$  a piece of length  $2\delta_0$  returns to one of the sets  $\Theta_i$ . This implies that if  $\omega \in \mathcal{P}_{n-1}$  and  $T_1|_\omega = n$  then  $|(f^N)^n(\omega)| < \gamma^N 6\delta_0$  and so

$$\frac{\nu_\Omega(\omega \cap \{R = T_1\})}{\nu_\Omega(\omega)} > \frac{2\delta_0}{6\delta_0\gamma^N} = \frac{1}{3\gamma^N}.$$

Hence

$$\frac{\nu_\Omega(\omega \cap \{R > T_1\})}{\nu_\Omega(\omega)} < 1 - \frac{1}{3\gamma^N} = \theta_2.$$

This means that  $\frac{\nu_\Omega(\mathcal{T}_2)}{\nu_\Omega(\mathcal{T}_1)} < \theta_2$ . Similarly we get

$$\frac{\nu_\Omega(\mathcal{T}_{k+1})}{\nu_\Omega(\mathcal{T}_k)} < \theta_2.$$

This implies that  $\nu_\Omega(\mathcal{T}_k) < \theta_2^k$  and  $\nu_\Omega\{R > T_k\} < \theta_2^k$ .

For any  $k$

$$\{R > n\} \subset \{T_k \geq n\} \cup \{T_k < n < R\}. \quad (3.7)$$

There is a number  $M$  such that if  $\omega \in \mathcal{P}_{n-1}$  then  $\omega \setminus \{R = n\}$  can be covered by less than  $M$  elements from  $\mathcal{P}_n$ .

Let  $K_p = \{k_i\}_{i=1}^p$  where  $k_1 < k_2 < \dots < k_p$  with  $k_p \geq n$  and  $k_{p-1} < n$ . Consider the set  $A_{K_p} = \{T_i = k_i, i = 1, 2, \dots, p\}$ . It can be covered by less than  $2^{k_p} M^p$  elements from  $\mathcal{P}_{k_p}$ . Since the length of  $\Omega$  is  $2\delta_0$  we have

$$\nu_\Omega(A_{K_p}) \leq \frac{2^{k_p} M^p 6\delta_0 (\gamma^N)^{-k_p}}{2\delta_0} = 3M^p \left(\frac{2}{\gamma^N}\right)^{k_p}.$$

If  $p \ll n$  then by Stirling's formula

$$\binom{n}{p} \approx \frac{n^{n+\frac{1}{2}} e^{-n}}{p!(n-p)^{n-p+\frac{1}{2}} e^{-n+p}} = \frac{e^{-pn}}{p!} \left(1 - \frac{p}{n}\right)^{p-n}$$

and so if  $\varepsilon$  is small enough

$$\begin{aligned} \sum_{p=0}^{[\varepsilon n]} \binom{n}{p} &\leq C_1 \sum_{p=0}^{[\varepsilon n]} \frac{e^{-pn}}{p!} \left(1 - \frac{p}{n}\right)^{p-n} \\ &< C_1 (1-\varepsilon)^{-n} \sum_{p=0}^{[\varepsilon n]} \frac{\left(\frac{n}{e}(1-\varepsilon)\right)^p}{p!} < C_1 (1-\varepsilon)^{-n} e^{\frac{n}{e}(1-\varepsilon)}. \end{aligned}$$

---

### 3.5. DECAY OF CORRELATIONS

Choose  $\varepsilon$  so small that  $\theta_3 = \frac{e^{\frac{1-\varepsilon}{\varepsilon}} M^{\varepsilon 2}}{(1-\varepsilon)\gamma^N} < 1$ . This can be done because of the choice of  $N$ . Then

$$\begin{aligned} \nu_{\Omega}\{T_{[\varepsilon n]} > n\} &\leq \sum_{p=0}^{[\varepsilon n]} \sum_{K_p} \nu_{\Omega}(A_{K_p}) \leq \sum_{p=1}^{[\varepsilon n]} \binom{n}{p} 3M^p \sum_{k_p=n}^{\infty} \left(\frac{2}{\gamma^N}\right)^{k_p} \\ &\leq C_2 \left(\frac{e^{\frac{1-\varepsilon}{\varepsilon}} M^{\varepsilon 2}}{(1-\varepsilon)\gamma^N}\right)^n = C_2 \theta_3^n. \end{aligned}$$

We use (3.7) to approximate  $\nu_{\Omega}\{R > n\}$ . We choose  $k = \varepsilon n$  and get

$$\nu_{\Omega}\{R > n\} \leq C_2 \theta_3^n + \theta_2^{\varepsilon n} \leq C \theta_1^n. \quad \square$$

We have proved that the return time  $R$  decays exponentially. This is not quite what we want.  $R$  is the time needed for a piece of  $\Theta_i$  to return to some  $\Theta_j$ , but we would need  $R$  to be the return time from  $\Theta_i$  to  $\Theta_i$ . Arguing as in [38], we can choose  $\Theta_* = \Theta_i$  for some  $i$  such that the return time  $R_*$  of  $\Theta_*$  satisfies  $\nu_{\omega}\{R_* > n\} < C\theta^n$  for some  $\theta < 1$ . This is sufficient to conclude Theorem 3.5.0.3. Note that the SBR-measure constructed with the method in [38] is the same measure as the SBR-measure constructed in Section 3.2.



# Bibliography

- [1] J. C. Alexander, J. A. Yorke, *Fat baker's transformations*, Ergod. Th. & Dynam. Sys. **4** (1984), 1–23
- [2] J. Buzzi, *Absolutely continuous invariant measures for generic multi-dimensional piecewise affine expanding maps*, Internat. J. Bifur. Chaos Appl. Sci. Engrg. **9** (1999), 1743–1750
- [3] J. Buzzi, *Absolutely continuous invariant probability measures for arbitrary expanding piecewise  $\mathbb{R}$ -analytic mappings of the plane*, Ergod. Th. & Dynam. Sys. **20** (2000), 697–708
- [4] J. Buzzi, G Keller, *Zeta functions and transfer operators for multidimensional piecewise affine and expanding maps*, Ergodic Theory Dynam. Systems **21** (2001), 689–716
- [5] V. P. Belykh, *Models of discrete systems of phase synchronization*, Systems of Phase Synchronization. Eds. V. V. Shakhildyan and L. N. Belyushina. Radio i Svyaz, Moscow, 1982, 61–176
- [6] A. Bertrand-Mathis, *Développement en base  $\theta$ ; répartition modulo un de la suite  $(x\theta^n)_{n \geq 0}$ ; langages codés et  $\theta$ -shift*, Bull. Soc. Math. France **114** (1986), 271–323
- [7] F. Blanchard,  *$\beta$ -expansions and symbolic dynamics*, Theor. Comp. Sci. **65** (1989), 131–141
- [8] R. Bowen, *Bernoulli maps of the interval*, Israel J. of Math. **28** (1977), 161–168
- [9] M. Denker, C. Grillenberger, K. Sigmund, *Ergodic Theory on Compact spaces*, Lecture Notes in Math., 527, Springer, Berlin, 1976
- [10] S. Eilenberg, *Automata, languages and machines*, vol. A, Academic press, London, 1974
- [11] P. Erdős, *On a family of symmetric Bernoulli convolutions*, Amer. J. Math. **61** (1939), 974–976

## BIBLIOGRAPHY

---

- [12] F. Hofbauer,  *$\beta$ -Shifts Have Unique Maximal Measure*, Mh. Math. **85** (1978), 189–198
- [13] F. Hofbauer, *On intrinsic ergodicity of piecewise monotonic transformations with positive entropy*, Israel J. of Math. **34** (1979) 213–237
- [14] F. Hofbauer, *On intrinsic ergodicity of piecewise monotonic transformations with positive entropy II*, Israel J. of Math. **38** (1981), 107–115
- [15] F. Hofbauer, *The structure of Piecewise monotonic transformations*, Ergod. Th. & Dynam. Sys. **1** (1981), 159–178
- [16] F. Hofbauer, *The maximal measure for linear mod one transformations*, J. London Math. Soc. **2** (1981), 92–112
- [17] F. Hofbauer, *Piecewise Invertible Dynamical Systems*, Probab. Th. Rel. Fields **72** (1986), 359–386
- [18] G. Keller, *Equilibrium states in ergodic theory*, London Mathematical Society Student Texts 42, Cambridge University Press, Cambridge, 1998, ISBN: 0-521-59420-0
- [19] T. Li, J. Yorke, *Ergodic transformations from an interval into if self*, Trans Amer. Math. Soc. **235** (1978), 183–192
- [20] D. A. Lind, *The entropies of topological Markov shifts and a related class of algebraic integers*, Ergod. Th. & Dynam. Sys. **4** (1984), 283–300
- [21] J. C. Oxtoby *Measure and category*, Graduate Texts in Mathematics 2, Springer-Verlag, New York-Berlin, 1971
- [22] W. Parry, *On the  $\beta$ -expansion of real numbers*, Acta Math. Acad. Sci. Hung. **11** (1960), 401–416
- [23] W. Parry, *Representations for real numbers*, Acta Math. Acad. Sci. Hung. (1964), 95–105
- [24] W. Parry, *Symbolic dynamics and transformations of the unit interval*, Trans. Amer. Math. Soc. **122** (1966), 368–278
- [25] W. Parry, *The Lorenz attractor and a related population model*, Lecture Notes in Math., 729, Springer, Berlin, 1979
- [26] Y. Peres, B. Solomyak, *Absolute continuity of Bernoulli convolutions, a simple proof*, Math. Research Letters **3** (1996), 231–236.



- 
- [27] Ya. B. Pesin, *Dynamical systems with generalized hyperbolic attractors: hyperbolic, ergodic and topological properties*, Ergod. Th. & Dynam. Sys. **12** (1992), 123–151
- [28] A. Rényi, *Representations for real numbers and their ergodic properties*, Acta Math. Acad. Sci. Hung. **8** (1957), 477–493
- [29] E. A. Sataev, *Invariant measures for hyperbolic maps with singularities*, Russian Math. Surveys **47** (1992), 191–251
- [30] E. A. Sataev, *Ergodic properties of the Belykh map*, J. Math. Sci. (New York) **95** (1999), 2564–2575
- [31] J. Schmeling, *Symbolic dynamics for  $\beta$ -shifts and self-normal numbers*, Ergod. Th. & Dynam. Sys., **17** (1997), 675–694
- [32] J. Schmeling, *A dimension formula for endomorphisms – the Belykh family*, Ergod. Th. & Dynam. Sys. **18** (1998), 1283–1309
- [33] J. Schmeling, S. Troubetzkoy, *Dimension and invertibility of hyperbolic endomorphisms with singularities*, Ergod. Th. & Dynam. Sys. **18** (1998), 1257–1282
- [34] K. Schmidt, *On periodic expansions of Pisot numbers and Salem numbers*, Bull. London Math. Soc. **12** (1980), 269–278
- [35] B. Solomyak, *On the random series  $\sum \pm \lambda^i$  (an Erdős problem)*, Annals of Math. **142** (1995), 611–625.
- [36] M. Tsujii, *Absolutely continuous invariant measures for piecewise real-analytic expanding maps on the plane*, Comm. Math. Phys. **208** (2000), 605–622
- [37] M. Tsujii, *Absolutely continuous invariant measures for expanding piecewise linear maps*, Invent. Math. **143** (2001), 349–373
- [38] L.-S. Young, *Statistical properties of dynamical systems with some hyperbolicity*, Annals of Math. **147** (1998), 585–650.