



LUND UNIVERSITY

Activity Report: Automatic Control 1998

Wittenmark, Björn; Dagnegård, Eva

1999

Document Version:

Publisher's PDF, also known as Version of record

[Link to publication](#)

Citation for published version (APA):

Wittenmark, B., & Dagnegård, E. (Eds.) (1999). *Activity Report: Automatic Control 1998*. (Annual Reports TFRT-4026). Department of Automatic Control, Lund Institute of Technology (LTH).

Total number of authors:

2

General rights

Unless other specific re-use rights are stated the following general rights apply:

Copyright and moral rights for the publications made accessible in the public portal are retained by the authors and/or other copyright owners and it is a condition of accessing publications that users recognise and abide by the legal requirements associated with these rights.

- Users may download and print one copy of any publication from the public portal for the purpose of private study or research.
- You may not further distribute the material or use it for any profit-making activity or commercial gain
- You may freely distribute the URL identifying the publication in the public portal

Read more about Creative commons licenses: <https://creativecommons.org/licenses/>

Take down policy

If you believe that this document breaches copyright please contact us providing details, and we will remove access to the work immediately and investigate your claim.

LUND UNIVERSITY

PO Box 117
221 00 Lund
+46 46-222 00 00

Activity Report

Automatic Control

1998



LUND INSTITUTE OF TECHNOLOGY
Lund University

Mailing address

Department of Automatic Control
Lund Institute of Technology
Box 118
SE-221 00 LUND SWEDEN

Visiting address

Institutionen för Reglerteknik
Lunds Tekniska Högskola
Ole Römers väg 1, Lund

Telephone

Nat 046-222 87 80
Int +46 46 222 87 80

Fax

Nat 046-13 81 18
Int +46 46 13 81 18

Generic email address

control@control.lth.se

WWW and Anonymous FTP

<http://www.control.lth.se>
<ftp://ftp.control.lth.se/pub>

The report is edited by Eva Dagnegård and Björn Wittenmark

Printed in Sweden
Universitetstryckeriet, Lund, May 1999

ISSN 0280-5316
ISRN LUTFD2/TFRT--4025--SE

Contents

1. Introduction 5
2. Internet Services 9
3. Economy and Facilities 11
4. Education 19
5. Research 23
6. External Contacts 45
7. Looking Back
on Computer Aided Control Engineering 49
8. Dissertations 63
9. Honors and Awards 71
10. Personnel and Visitors 73
11. Staff Activities 77
12. Publications 93
13. Reports 103
14. Lectures by the Staff outside the Department 109
15. Seminars at the Department 119

1. Introduction

This report covers the activities at the Department of Automatic Control at Lund Institute of Technology (LTH) from January 1 to December 31, 1998.

The budget for 1998 was 24.5 MSEK, which is a slight increase compared to last year. The proportion coming from the University is still reducing; two years ago it was 53%, this year it is only 40%.

Two PhD theses by Johan Nilsson and Jörgen Malmberg were defended, which brings the total number of PhDs graduating from our department to 50. Six Lic Tech theses by Mats Åkesson, Jonas Eborn, Mattias Grundelius, Erik Möllerstedt, Martin Öhman, and Hélène Panagopoulos were completed. Three new PhD students have been admitted during the year: Anton Cervin, Ari Ingimundarson, and Hubertus Tummescheit.

In the civilingenjör (master) program we have eight courses. The total number of students that finished the courses was 588, and 21 students completed their master theses. The total teaching effort corresponds to about 100 full-year equivalents.

Research at the department has continued in our established areas: adaptive and robust control, real-time control, computer-aided control engineering, and applications in robotics, power systems, and biotechnology.

Some members of the department have received honors and awards, see Chapter 9. For instance, Karl Johan Åström received an honorary doctor degree from University of Glasgow and the Distinguished Member Award from IEEE Control Systems Society.

A highlight of the year is that the Swedish Foundation for Strategic Research has granted a research contract for a center on *Chemical Process Design and Control*. The application has been put together by the department in cooperation with chemical engineering departments

Introduction

at Chalmers University of Technology. The center will make multidisciplinary research with applications in the chemical, pulp and paper, and food industries (<http://www.control.lth.se/cpdc/>).

In June 1998 the department organized the national conference “Reglermöte ’98” (Control Meeting ’98) in Lund. This is a semi-annual control conference for university and industry in Sweden. The conference had 270 participants of which 125 came from industry. 75 papers and posters were presented, of which 25 were from industry, and 11 companies participated in the exhibition. The conference was a good meeting place for industry and academia. One of the highlights at the meeting was a song composed and performed by our PhD students Johan Eker, Erik Möllerstedt, and Lotta Eker. A special industrial course on PID and fuzzy control was also organized in connection with the conference.

Our retrospect this year, Chapter 7, describes our research in computer-aided control engineering during the years 1985–1998. Our research has resulted in close cooperation with the company Dynasim AB in Lund and the work with developing the new object-oriented modeling language Modelica™. This research shows how results from academia in an excellent way can be transferred to industry.

Some statistics from five years is given in the table below. Notice that the entry 95-96 covers a period of 1.5 years.

	93/94	94/95	95-96	97	98	Sum
Books	0	2	1	2	1	6
Papers	18	17	30	15	24	104
Conference papers	29	24	71	45	37	206
PhD theses	1	3	3	1	2	10
Licentiate theses	0	0	2	3	6	11
Master theses	34	23	40	18	20	135
Internal reports	16	15	18	11	11	71

Acknowledgements

We want to thank our sponsors, Swedish National Board for Industrial and Technical Development (NUTEK), Swedish Research Council for Engineering Sciences (TFR), Swedish Natural Science Research Council (NFR), Swedish Medical Research Council (MFR), Active Biotech, Lund Research Center AB, Elforsk, the European Council, FAMIMO, Foundation for Strategic Research (SSF), MISTRA, Pharmacia & Upjohn, Sydkraft AB, Swedish Institute of Applied Mathematics (ITM), and Tetra Pak Research & Development AB, for their support to our projects.

2. Internet Services

World Wide Web

Our homepage first appeared on the World Wide Web (WWW) in April 1994. Visit our homepage at this address:

```
http://www.control.lth.se
```

Our web site contains information about personnel, publications, seminars, education, etc. It also contains fairly complete lecture notes for many courses, and in some cases software tools such as Matlab toolboxes developed at the department.

During the year our web has been accessed from far more than 15,000 sites all over the world.

Electronic Mail

All personnel can be contacted by electronic mail. A personal email address consists of the full name and the department address, written in the form `FirstName.LastName@control.lth.se`. Double names are separated by underline, hyphens are treated as ordinary characters, and accents are ignored. Examples:

```
karl_johan.astrom@control.lth.se  
bjorn.wittenmark@control.lth.se  
karl-erik.arzen@control.lth.se
```

Our web page <http://www.control.lth.se/telemail.html> contains a complete list of email addresses. The department also has a generic email address:

```
control@control.lth.se
```

Letters to this address are continuously read by the postmaster and forwarded to the appropriate receiver.

Anonymous FTP

Via FTP you have access to various documents. The URL is:

```
ftp://ftp.control.lth.se/pub
```

Under the subdirectory *cace* you find documents regarding Computer Aided Control Engineering (CACE) and the program OmSim. There are versions of OmSim for Sun-4 workstations and HP workstations under the X Window System or PCs running under the operating system Linux. OmSim is implemented in C++ and uses only public domain software.

Under *books* you find material regarding the books *Adaptive Control* and *Computer-Controlled Systems*, both written by K. J. Åström and B. Wittenmark. Some of this material is used in the engineering courses.

During 1998 these web resources have been accessed from numerous different computers outside Lund University, for instance, CACE from 420 different sites, Adaptive Control from 260 sites, and Computer Control Systems from 651 sites.

3. Economy and Facilities

The turnover for 1998 was 24.5 MSEK, an increase of 1.5 MSEK from last year. The income comes from the University and from external grants; the distribution is shown below.

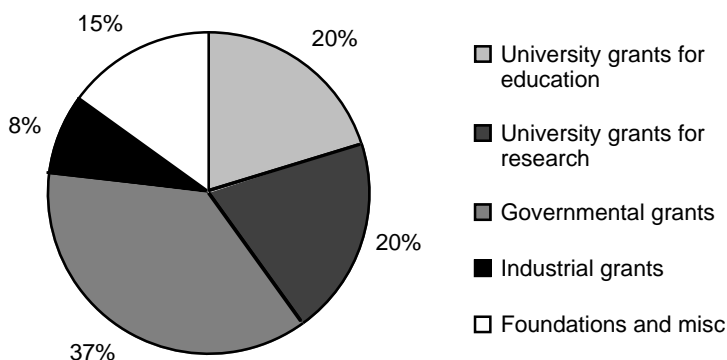

The reduction in the proportions coming from the university continues. Two years ago it was 53%, now it is 40%.

Funding

Lund University provides partial support for graduate students. The majority of our research is, however, externally funded from governmental agencies and industry. During 1998 we had the following contracts:

- TFR – Block grant
- NUTEK – Modelling and Simulation of Complex Systems
- NUTEK – Lund Research Programme in Autonomous Robotics
- NUTEK – Motion Control

Economy and Facilities

- NUTEK – Process Control for Cultivation of Genetically modified micro organisms
- NUTEK – Heterogeneous Systems
- NUTEK – Real-Time Systems
- NUTEK – Safety Distributed Control of Critical Mechanical Systems
- Governmental funding for research collaboration with Caltech
- STINT – STINT Fellowship Programme “Complex Systems”
- SSF – Computational Analysis of Dynamical Models
- SSF ARTES – Integrated Control of Scheduling
- MISTRA – Dynamic Modeling of an Ecocyclic Pulp Bleaching Plant
- ELFORSK – Modeling of Electric Power and Distribution Networks and Components
- Sydkraft – Modeling and Control of Energy Processes
- Pharmacia & Upjohn – Multivariable Control of Genetically engineered *E. coli*.
- EU ESPRIT LTR – Fuzzy Algorithms for MIMO Control Systems (FAMIMO)
- EU ESPRIT LTR – Heterogeneous Hybrid Control (H2C)
- EU ESPRIT NSF – Tools for the Analysis of Hybrid Systems

The Block grant from TFR is long range and some of the NUTEK projects are also long range. Several projects do, however, have a duration of only two years. To match these with the duration of a PhD, which is much longer, we have an internal research planning that is much more long range and we are careful to bid on projects that fit our long range research plan. This has proven an effective way to match short-term funding to long-term planning.

Facilities

The main facilities are laboratories and computer systems. Our main computing resource is a network of Unix workstations. All members of the department have on their desks workstations connected to this network. For all academic staff the machines are SparcStation Ultra1 or better. There is also a powerful central computer for heavy computations.

The teaching laboratories are based on desktop processes and personal computers. These laboratories are used in all our courses. The introductory courses give a heavy load on the teaching laboratories because of the large number of students. There are almost 600 students, and on the average they spend about 20 hours each in the lab.

Lab processes that are used most frequently are tank systems, servos, and ball and beam systems. These have all been developed at the department. We have acquired flexible servos from Educational Control Products, and a "Pendubot" from University of Illinois at Urbana-Champaign.

For a number of years we have used Windows-NT as a (pseudo) real-time system. That development has now stopped, because the performance obtained was too bad, and because the cost in manpower to maintain the systems was too high. Instead we have started to use Linux for the same purpose. This shows great promise, because the performance is much better, and a set of Linux machines is much easier to maintain. In simple cases we can use Matlab and Simulink to code the controller and the user interface, obtaining sampling periods down to 1 ms on a 133 MHz Pentium.

We use a standard RedHat 5.2 Linux distribution with the UTIME kernel patch from University of Kansas (<http://hegel.ittc.ukans.edu/projects/utime/index.html>), with small local modifications. More extensive packages to even further enhance the real-time properties of Linux are available, and we will continue to investigate these. In this context we are also investigating Java as a tool for operator communication, and to some extent for the control algorithms themselves.

Robotics Laboratory

Purpose of Research

Robot control systems and other manufacturing equipment are traditionally closed. This circumstance has hampered system integration of manipulators, sensors, and other equipment and such system integration has often been made at an unsuitably high hierarchical level. In our Robotics Laboratory, we try to show how to organize open robot control systems and to verify these ideas by means of experimental verification.

Experimental Environment The experimental platform uses real industrial robots from ABB with the control systems modified to permit new and customized control principles. Powerful workstations are used as host computers, attached in a way to permit the use of standard mathematical software for analysis of real-time data of the goal system—*e.g.*, sensor-based motion control and adaptive algorithms for path tracking.

To support prototyping of task-level programming and autonomous operation, the IGRIP off-line programming system from Deneb Inc. has been connected via the network to the robots in both directions. This arrangement permits remote control and feedback using the task-level programming tool.

The developed experimental robot control system is unique in the sense that it is based on modern robots commonly used in the industry, still maintaining important safety functions of the original system, but allowing the researcher full access to control and programming functions. An overview of the reconfigured Irb-2000 system is shown in Figure 3.1. A similar open system based on the Irb-6 robot is also available.

The master computer in the VME computer is based on a M68040 microprocessor. Supervision and safety functions are implemented on a M68030 board, well separated from the rest of the system to prevent damage of the robot. Digital Signal Processors (DSP) are used for low-level control and filtering of sensor signals at high data rates. An

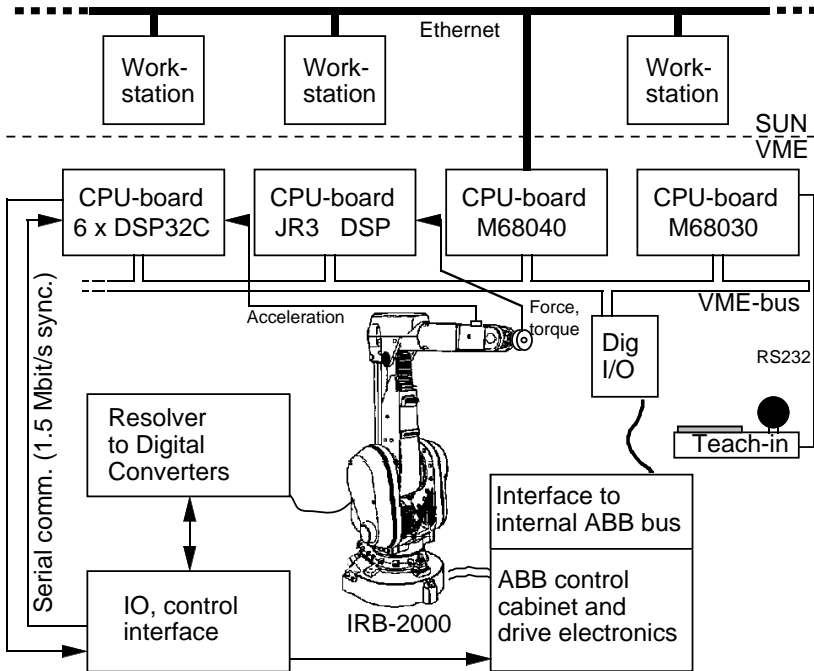

Figure 3.1 Overview of the Irb-2000 part of the laboratory, excluding gripper control and vision hardware. VME-boards with PowerPC processors are currently added to the system.

additional DSP board belongs to the force-torque sensor (JR3). A six DOF joystick (DLR) can be connected to a serial port of the M68030 supervision computer for data transfer to memory accessible from the VME bus.

The Irb-2000 is equipped with AC motors, and because we want to be able to implement all of the control layers, the interfacing to the S3 control system used has to be at a lower level compared to the Irb-6 interface. The system is simply cut at the drive unit interface, which means that also the AC motor current references must be computed in such a way that the desired torque is achieved. The AC motor control should be computed with a rate of at least 1 kHz (preferably 2 kHz).

Economy and Facilities

Otherwise, the torque control will not be good enough, particularly for high speeds. This means that the requirements on computing power are quite severe. Our solution is to use Digital Signal Processors (DSP).

The same type of resolver-to-digital conversion as for the Irb-6 interface is used, but with the accuracy of 14 bits per motor revolution and 8 revolution counting bits in hardware. Both hardware and software are prepared for a resolution of 16 bits per motor turn. Thus, joint angles are provided as absolute 24 bit values. Using commercially available R/D converters (RDC) with an internal analog velocity signal and a phase-locked loop makes it possible to get proper anti-alias filtering by tuning that loop. This is hardly possible with optical encoders or with other types of resolver measurement principles (a higher sampling frequency and the roll-off of the process then have to be used instead). The 24 bit position data for the motors can simply be differentiated to get the speed; that signal has been filtered in the analog phase locked loop. The sampling period will then, however, be quite crucial. The next generation of the sensor interface will therefore also provide the speed value from the RDC chip. The R/D conversion hardware is located on the robot which reduces the required length of the wires for analog signals to a minimum.

Systems and Control Issues

Features of interest are Adaptive control algorithms; Force control tasks; Open real-time control system permitting rapid prototyping of control algorithms; Integration of task-level programming of the manufacturing process with model-based motion control, see Figure 3.2.

Task-level Programming One direction of research represents an enhanced use of work-space sensor information in robotics and feedback control. The environment of robots are dynamic and must be observed by sensor equipment. For adaptation of task realizations to the environment, the robot control system must have the ability to support and react to the observed information. An event based robot control system with these advantages is described, the event-based control system operating from a model description of the world and the task. In the world model, all objects significant for the task in the robot

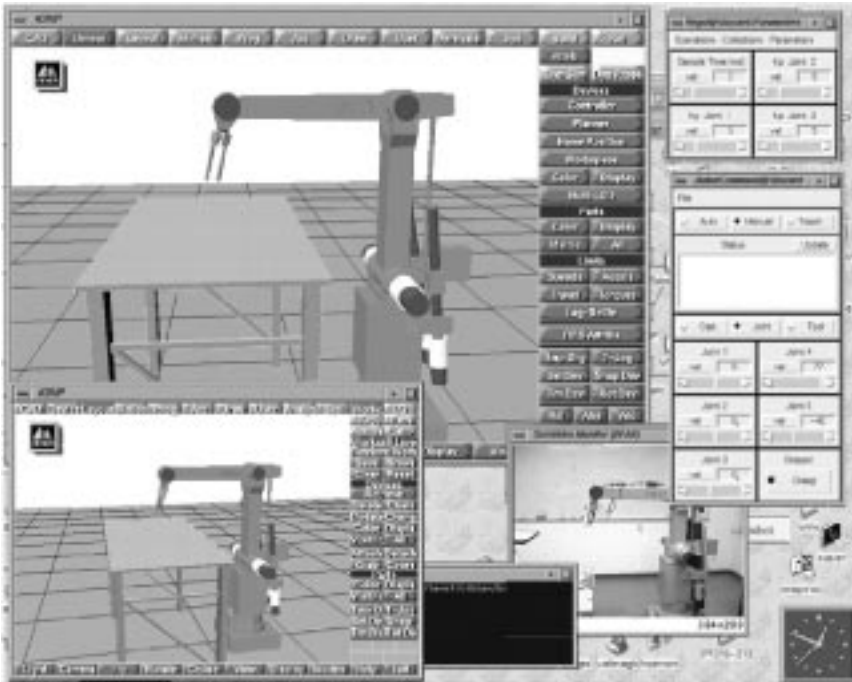

Figure 3.2 Images of an industrial robot (ABB Irb6) as viewed in the task-level programming world and in the real world and in feedback-supported task-level programming.

work cell are represented and generated during a visual task oriented programming session. The task realization is managed by the control system in small parts or executable events. An executable event is fired and realized when its preconditions are fulfilled. Changes in the work cell are detected by sensors and the information is used to update the world model, which all events are founded upon. Sensor information has influence on planning as well as control of motion and application processes.

Another focus is a task-oriented robot programming method and the associated control system. The purpose of creating a new programming

Economy and Facilities

environment is to give reusability, maintainability and reliability to the robot program code, all key factors in efficient programming. The whole system is focused on objects corresponding to physical objects and processes in the environment. In the task-oriented programming system, tasks are described as states of objects and their dependencies.

Academic Cooperation One purpose of our Robotics Laboratory is to promote cross-discipline collaboration between various departments. Currently, cooperation includes Department of Computer Science, Division of Robotics at the Department of Mechanical Engineering, Department of Industrial Electrical Engineering and Automation, Division of Cognitive Science, and the Computer Vision Group at the Department of Mathematics. As the field of robotics is wide and multi-disciplinary, it is of mutual benefit to share the experimental platform.

Industrial Cooperation Supported with NUTEK sponsored research projects, we have industrial cooperation with our industrial partners at ABB Robotics and ABB Corp. Research.

4. Education

Engineering Program

The engineering education follows the central European systems with a 4.5 year program leading up to the degree “civilingenjör” (civ.ing.), which corresponds to an MSc in the US and British systems.

Automatic control courses are taught as part of the engineering curricula in Engineering Physics (F), Electrical Engineering (E), Computer Engineering (D), Mechanical Engineering (M), and Chemical Engineering (K). Our courses are listed in Table 4.1.

During 1998, 588 students passed our courses and 21 students completed their master-thesis projects. The number of registered students corresponded to 100 full-year equivalents during the year.

Topics for the master theses were in the following areas: Nonlinear systems (1), Adaptive control and Autotuning (3), Modeling and simulation (5), Signal processing (1), Control design (7), Real-time systems (1), Robotics and servo systems (1), Process control (1). A list of the master theses is given in Chapter 13.

Learning Tools for Control

The department has developed a collection of interactive computer tools, CCSDemo and ICTools, which run under Matlab-5. The tools are described in articles by Wittenmark *et al.*¹ and by Johansson *et al.*² and have been observed in the technical magazine *ComsolNews*.³

¹Wittenmark, B. H. Haglund, and M. Johansson: “Dynamic Pictures and Interactive Learning,” *Control Systems Magazine*, **18:3**, pp. 26–32, June 1998.

²Johansson, M., K. J. Åström, and M. Gäfvert: “Interactive tools for education in automatic control.” *IEEE Control Systems*, **18:3**, pp. 33–40, June 1998.

³Johansson, L.-Å.: “Bättre pedagogik med Matlab (Increased learning using Matlab),” *ComsolNews*, No 1, February 1998, pp. 12–13.

Education

Table 4.1 Courses given at the department and the number of students that passed the courses.

Reglerteknik AK–FED <i>FRT010</i> (Automatic Control, basic course)	278
Reglerteknik AK–M <i>FRT060</i> (Automatic Control, basic course)	112
Processreglering (K) <i>FRT080</i> (Automatic Process Control)	31
Digital Reglering (FED) <i>FRT020</i> (Computer-Controlled Systems)	67
Realtidssystem (FED) <i>FRT031</i> (Real-Time Systems)	38
Systemidentifiering (FED) <i>FRT041</i> (System Identification)	15
Adaptiv reglering (FED) <i>FRT050</i> (Adaptive Control)	24
Olinjär reglering och Servosystem (M) <i>FRT075</i> (Nonlinear Control and Servo Systems)	23
Internationell projektkurs i reglerteknik <i>FRT100</i> (International Project Course in Automatic Control)	7
Examensarbete 20 poäng <i>FRT820</i> (Master-thesis project, 4 months)	21

More information about our interactive learning tools is available at <http://www.control.lth.se/~ictools>.

Bicycles, specially built for a summer course in 1997, are used to demonstrate stable and unstable systems and thereby give a better understanding of control problems. These strange-looking bicycles were built after an idea from Professor Klein in Illinois, who inspired Karl Johan Åström to introduce them in education. The bicycles are featured in an article in *LTH Nytt*.⁴

⁴Frankel, B. and A. Bengtsson: "Lär reglerteknik med cykel (Using bicycles to learn control)," *LTH Nytt*, No 2, May 1998, pp. 14–15.

Information on WWW

Many students have access to Internet via Lund University. Therefore we have made a great effort to present the education on web pages. Each course in the engineering program has its own homepage, where the students can find course plans, lecture notes, documentation, manuals, old exams, etc.

We have also made information sheets about the engineering courses and the doctorate program, and they were received very well.

You find the education links at <http://www.control.lth.se/education/>.

Doctorate Program

Two PhD theses by Johan Nilsson and Jörgen Malmborg were completed during the year. This brings the total number of PhDs graduating from our department to 50. Six Lic Tech theses by Mats Åkesson, Jonas Eborn, Mattias Grundelius, Erik Möllerstedt, Martin Öhman, and Hélène Panagopoulos were defended. Abstracts of the theses are given in Chapter 8.

We have admitted three new PhD students during the year: Anton Cervin, Ari Ingimundarson, and Hubertus Tummescheit.

The following PhD courses were given:

- Case Studies in Control (T. Hägglund) 5 points
- Nonlinear Control (A. Rantzer) 5 points
- Discrete Event Systems (K.-E. Årzén) 5 points
- Literature Seminars (B. Wittenmark) 3 points
- Project Course in Synthesis (K.-E. Årzén and B. Bernhardsson) 8 points
- Hilbert Space Theory (B. Bernhardsson) 3 points
- Robust Control using H_∞ Loop Shaping (G. Vinnicombe) 2 points

Industrial Course "PID and Fuzzy"

On June 10, the day before the national control conference "Reglermöte '98," we organized an industrial course named "PID and Fuzzy." The reason for choosing these topics was that we knew that there is an industrial interest in the new research results concerning the old PID controller, e.g., automatic tuning, design methods, and supervisory functions. There is also a desire to understand what fuzzy control is and where it is beneficial to use it.

The first part of the course treated the PID controller, its structure, tuning, and usage in process control. It was lectured by Karl Johan Åström and Tore Hägglund. The second part, lectured by Karl Erik Årzén, treated fuzzy logic, fuzzy control, and fuzzy nonlinearities.

We had 56 participants in the course, 47 coming from industry and 9 from universities.

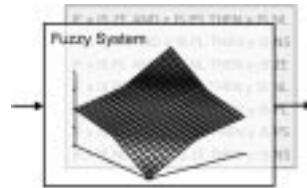
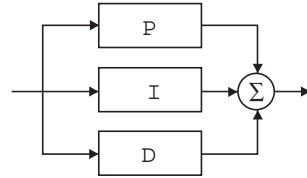

5. Research

The goal of the department is to provide students with a solid theoretical foundation combined with a good engineering ability. This is reflected in the research program which, broadly speaking, is divided into theory and applications.

The major research areas are:

- Tuning, adaptation, and robust control
- Computer aided control engineering
- Applications

In the following presentation the research is broken down with a granularity of a PhD thesis. There are of course strong relations between the different projects.

Tuning, Adaptation, and Robust Control

This section covers research projects that are related to adaptive and robust control.

Friction, Modeling, and Compensation

Researchers: Karl Johan Åström and Magnus Gäfvert

This work is carried out in close collaboration with Prof. Canudas de Wit at LAG in Grenoble. The research has been focused on finding the possibilities and the limitations of the LuGre model for friction. The model has been used to investigate friction compensation for a Furuta pendulum. The experiments are quite striking because the effects of friction compensation are clearly visible in a drastic reduction of the size of the limit cycle. The work on friction compensation has received significant interest. We were invited to present our results at a workshop for the IEEE CDC in Tampa Florida in December.

Research

There is a growing interest in friction phenomena in a wide range of fields, such as surface physics, surface chemistry, and geophysics. One reason being the drastically improved measurement techniques that have recently been developed. We are following this development and we are establishing contacts with leading researchers in several different fields. An interesting feature is that some models developed in geophysics have a strong similarity to the LuGre model.

Control of Uncertain Systems

Researchers: Anders Rantzer, Andrey Ghulchak, Lennart Andersson and Bo Bernhardsson

Recent developments in control theory are closely linked to the rapid improvements of computer tools for design, analysis, and simulation. The aim of this project is to pursue this combined development of theoretical and computational tools, and define new directions motivated by industrial problems. Our main investigations deal with stability and performance analysis for systems with uncertainty as well as controller optimization.

For several years, we have been developing the analysis framework based on integral quadratic constraints. This work is done in cooperation with prof. A. Megretski at MIT, who was last visiting us in August 1998. Ulf Jönsson, who finished his PhD at the department in 1996 is currently doing a postdoc with Megretski. This year, the joint activity has resulted in publications devoted to systems with forced oscillations and systems with rate limiters. A tutorial paper has been prepared together with a Matlab toolbox named IQCbeta (See <http://www.control.lth.se/~rantzer/IQCbeta.html>) to support the analysis of interconnected systems.

Some good benchmark examples from power technology have motivated us to study stability robustness of differential-algebraic systems. The effects of parametric uncertainty, such as load variations in the power networks, are hard to analyze, both because of the system size and because the equilibrium point varies with the parameters. To handle variations in the equilibrium point is an important problem for nonlinear systems and we are approaching it using so called μ -analysis.

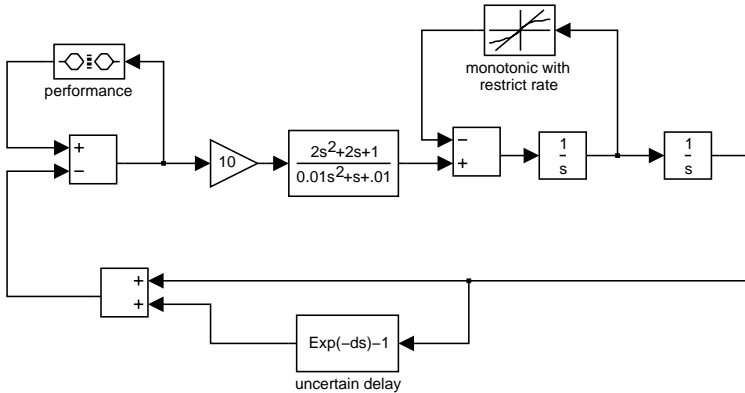

Figure 5.1 An analysis model defined using the graphical interface of IQCbeta. The “performance” block specifies an input-output pair and an upper bound on the gain is computed by convex optimization

Since Andrej Ghulchak was employed as a guest researcher in September, he has contributed to our studies of optimization with frequency domain constraints. This problem area has a wide variety of applications in control and the initial investigations have been focused on a convex parameterization of controllers that achieve robustness with respect to parametric uncertainty.

Modeling with Quantified Accuracy

Researchers: Anders Rantzer, Lennart Andersson, Sven Erik Mattsson, and Martin Öhman

This project has a two-fold background: experiences of object oriented modeling techniques from the Omola project and recent developments in robustness analysis. To deal with uncertainties we need concepts to describe them and tools for working with them. If a model is developed from measured data using system identification methods we can get various statistical measures describing uncertainties. When models are developed from first principles, approximations are sources to uncertainty.

Mathematical tools for quantification of accuracy have been developed in the context of robust control. For example, the notions structured uncertainty and integral quadratic constraints, have been introduced to quantify the effects of neglected dynamics and parameter deviations.

Lennart Andersson's licentiate thesis introduced new methods and error bounds for reduction of uncertain models. Currently, he is pursuing these methods further in the context of power networks. To analyze a regional network, it is necessary to simplify the models of network components far away from the region. The goal of the study is to get more systematic methods for such simplifications.

Another direction was taken by Martin Öhman, who finished his licentiate in October 1998. He showed how nonlinear model simplification can be done by studying the behavior near specific trajectories. These trajectories can, for example, be the trajectories of an identification experiment, or the trajectories of some desired state transitions. Öhman's initial studies have been based on a boiler model for a power plant.

Hybrid Control

Researchers: Karl Johan Åström, Bo Bernhardsson, Sven Hedlund, Karl Henrik Johansson, Mikael Johansson, Jörgen Malmberg, and Anders Rantzer

Hybrid systems is an active research area on the border between Computer Science and Automatic Control. One typical hybrid system consists of a physical process under control and supervision of a discrete computer. Physical systems may show behavior that is convenient to model as discrete events. Examples are mechanical systems with backlash, dead zones, and static friction, or electrical systems with switches. A valve in a process model may become stuck because of high friction.

In this project it is attempted to use switching strategies to improve the performance of simple controllers and facilitate controller design. We have implemented a hybrid control system consisting of a time optimal controller and a PID controller together with a switching algorithm. The system shows very good performance when controlling the levels of a double tank system.

Another approach to hybrid systems has been developed by Mikael Johansson in cooperation with Anders Rantzer. The work is directed towards numerical methods for analysis of stability and performance. Piecewise quadratic Lyapunov functions and cost functions are computed by convex optimization. The method is a generalization of earlier work on quadratic stability and gives big flexibility for analysis of hybrid systems.

We have also investigated how simulation tools can be improved to give better results for hybrid systems. As prototype systems, we have studied simple discontinuous differential equations. "Sliding modes," which were introduced by the Russian mathematician Filippov, have been analyzed. For example, we have derived conditions for the approximation of a solution by a sliding mode for some systems. This simplifies the simulation of the system.

The department is one of four partners in the ESPRIT-project "Heterogeneous Hybrid Control".

Automatic Tuning of PID Controllers

Researchers: Karl Johan Åström, Tore Hägglund, and Hélène Panagopoulos

This project has been in progress for over ten years, and resulted in industrial products as well as several PhD theses. A monograph on PID control that is based on experiences obtained in the project has also been published.

During the last year, the project has focused on PID controller design. Efficient numerical methods for designing PI and PID controllers based on non-convex optimization have been developed. The design is based on optimization of load disturbance rejection with constraints on sensitivity. Setpoint responses are treated using a two-degree of freedom structure that enables setpoint weighting. If needed, a low-pass filtering of the setpoint is also applied. Finally, measurement noise is handled by the design of a low-pass filter for the measurement signal.

The project has resulted in a licentiate thesis by Hélène Panagopoulos.

Autonomous Control

Researchers: Karl Johan Åström, Tore Hägglund, and Anders Wallén

This project has been inspired by industrial experiences on tuning of PID controllers. The aim is to demonstrate a concept of a single-loop controller with as much autonomy as possible. It is supposed to help the operator start up, tune, and monitor the control loop. The start-up procedure should contain tools that can provide *loop assessment* in order to detect non-linearities, faulty equipment, poorly tuned processes, etc. Loop monitoring includes actuator *diagnosis* and *performance assessment*. The latter function attempts to determine if the loop performs according to its specifications and also to compare with historical data and theoretical limits.

The autonomous controller contains a wide range of algorithms and methods of quite different nature. It includes traditional real-time computations, sequential methods for loop assessment and tuning, and knowledge-based methods. We have a G2 prototype implementation using extended Grafset for structuring the control algorithms. A major concern has been to design supervisory logic for the various algorithms. An interface between Matlab and G2 has been developed to increase the computational power.

The research on supervisory functions for process control has continued. Two supervisory functions for detection of oscillating control loops and sluggish control loops, respectively, have been developed at the department. These methods have been tested and verified on industrial plants through both master-thesis projects and PhD projects.

An interactive tool for simple process identification has also been developed using Matlab. The user may graphically fit the step response of a selected model structure to the data, and also perform a least squares fit. The tool gives a fast way of obtaining a simple process model that can be used for, *e.g.*, controller tuning.

Integrated Control and Diagnosis

Researchers: Karl-Erik Årzén and Mikael Petersson

This project is sponsored by TFR/SSF over a five years period by funding, in cooperation with ABB Corporate Research, an industrial

PhD position for Mikael Petersson. The goal of the project is the monitoring and diagnostics of industrial processes, and applying and evaluating advanced theory in this area.

During the year Mikael Petersson has been investigating and implemented change detection algorithms. The focus of research has now turned to control loop performance monitoring (CLPM). The multivariate CLPM is of special interest due to the industrial background and the frequent occurrence of MIMO-processes in industry.

Integrated Control and Scheduling

Researchers: Anton Cervin, Johan Eker, Anders Blomdell, and Karl-Erik Årzén

The focus of the project is practical management of hard real-time demands in embedded software. The approach is to combine control theory and scheduling theory in such a way that the nominal requirements on hard deadlines for control systems can be relieved. The approach taken is based on using dynamic feedback from the scheduler to the controllers and from the controllers to the scheduler.

The project which is funded by the ARTES real-time systems network within SSF is a cooperation with Department of Computer Science, LTH, Sigma Exallon AB, DDA Consulting, and University of Illinois.

System Identification

Researchers: Rolf Johansson in cooperation with Prof. M. Verhaegen, TU Delft

An identification algorithm that effectively fits continuous-time transfer functions and finite-bandwidth noise models to data has been published. Analysis of this class of algorithms proves convergence properties similar to that of maximum-likelihood identification of discrete-time ARMAX models. A substantial improvement of the identification accuracy of continuous-time zeros appears to be an important and attractive property of the new algorithm. One research direction that is currently pursued is system identification methodology suitable for multi-input multi-output systems for which matrix fraction descriptions are not unique. A promising approach to system identification appears to be the continued-fraction approximation and we have published a number of new matrix fraction descriptions and theoretical results that

resolve such problems of uniqueness. However, several theoretical problems remain to be solved with regard to algorithm efficiency, statistical properties, and validation aspects.

Analysis of Approximations to Dual Control

Researchers: Björn Wittenmark in cooperation with Jan Holst and Bengt Lindoff, Department of Mathematical Statistics, LTH

The dual control problem for time-varying or non-linear stochastic systems is inherently analytically and computationally intractable due to the demand of alternating minimizations and mean value computations. Hence, it has to be approached using approximations, leading to suboptimal dual control. The core of successful approximative controllers is their ability to be able to consider future changes in the development of the parameters.

In this project we present an analysis of the dual control concept and a comparison between a number of suboptimal controllers. The analytical comparisons are based on a reformulation of the dual control problem. This reformulation makes it possible to interpret and understand the nature of different approximations to dual control, in particular the Adaptive Predictive Controller (APC), developed in the PhD thesis of Bengt Lindoff at the Department of Mathematical Statistics, and the Active Suboptimal Dual Controller (ASOD), that has been developed at the Department of Automatic Control. Furthermore, the work makes the origin of the computational problems encountered more clear and suggests new alternatives for approximation.

Computer Aided Control Engineering

Computer Aided Control Engineering, CACE, has been a major area of research at the department for a long time. It has the dual purpose of providing tools for making control engineering much more cost effective and it also provides a glue between many different research projects.

During 1998 the focus has been on the design and development of Modelica as well as tools for modeling and simulation of hybrid systems.

Major applications have been power generation and power distribution. Sven Erik Mattsson, one of our senior researchers, has in August 1998 joined our research partner Dynasim to work with the future development of Modelica.

The Looking Back section of this activity report gives a thorough overview of the CACE project for 1985–1998, see page 49.

Modeling and Simulation of Complex Systems

Researchers: Hubertus Tummescheit, Jonas Eborn, Sven Erik Mattsson, Anders Rantzer, and Tomas Schönthal

This project is a part of NUTEK's research program on Complex Systems. The main aim of this project is to develop methods and computer tools which support development and use of mathematical models. Structured model libraries and more application specific tools are developed in other related projects as described below in cooperation with external partners.

The basic idea is to support reuse, so that a model component can be used as a part in different applications to solve a variety of problems. Good model libraries should allow a user to make the desired model simply by combining components. Computer tools shall automate the analysis and manipulation, which the user have to do manually today to get the problem on a form that is efficient for numerical solution.

The project started as a computer tool development project. After the final version of OMSIM (see Looking Back, page 49) it shifted towards model library development and model language standardization. The department is an active member of the Modelica effort, which started at a meeting in Lund in 1996. With support from ESPRIT, "Simulation in Europe", seven design meetings were held before September 1997. Then Modelica Version 1.0, the new object-oriented modelling language, was fixed. Now, with Version 1.1, several companies and universities have announced Modelica based simulation tools for 1999. The language definition and other information on the Modelica effort are available on the web site <http://www.Modelica.org>.

The Modelica effort started in the continuous time domain since there is a common mathematical framework in the form of differential-

algebraic equation (DAE) systems. Modelica version 1 is based on DAE systems with some discrete event features to handle discontinuities and sampled-data systems. Our research focuses now on modeling and simulation of more general hybrid systems. This is a wide open area, where there are many fundamental questions to answer such as which are the natural representations and how are these models simulated in an efficient way.

Development of model libraries in Modelica is important and it is an aim of the applied projects described below to contribute to this.

Modeling and Control of Energy Processes

Researchers: Karl Johan Åström, Rodney Bell, Jonas Eborn, Sven Erik Mattsson, Bernt Nilsson, James Sørli, and Martin Öhman

The boiler models have been improved. We have now good physics-based nonlinear models that describe steam generators. The boiler models have been used as test cases for model reduction procedures. We have participated in a benchmark on level control in steam generators organized by EDF. We are actively participating in the Modelica effort. Hubertus Tummescheit is maintaining the Modelica Home Page. Much of the modeling work is now directed towards development of Modelica libraries. Particular attention has been given to media models because we have found that standard media models are not well suited for dynamic simulation. The reason is that the functions that are commonly used do not have a representation that is suitable for dynamic simulation. There are also difficulties with discontinuities. A consequence is that simulations with realistic media models are very slow. We have started to develop efficient techniques for media modeling that are well adapted to dynamic simulation.

Analysis of Electrical Power Quality in Distribution Networks and Loads

Researchers: Erik Möllerstedt, Bo Bernhardsson, and Anders Rantzer

In the previous project “Modeling of Electricity Distribution Networks and Components” we developed a model structure that allows efficient aggregation and simulation of large structures of nonlinear loads attached to a radial distribution network. The model structure simplifies

simulation of the periodic behavior in a network at steady state. It is a non-iterative and fast procedure without convergence problems. A modeling method for harmonic studies of nonlinear loads has been investigated. The method makes aggregation into submodels, so called harmonic Norton models, possible. The method is described in a licentiate thesis by Möllerstedt presented in April 1998.

The method exploits that the loads are connected in parallel, which means that the voltage is approximately the same for all loads and that there are norms for allowed voltage distortion. Thus, it is reasonable to assume a linear relationship, $I = I_0 + Y(V - V_0)$, between the Fourier coefficient vectors of the current, I , and voltage V , where I_0 is the nominal current spectrum when the voltage is nominal V_0 . The matrix Y can be interpreted as an admittance matrix that describes how the current spectrum is affected by changes in the voltage spectrum. Each column in Y describes the change in the current spectrum when a small component of a certain harmonic is added to the nominal voltage. If the component is linear then Y is diagonal. The parameters, I_0 and Y for a component can be obtained from simulations of a complex component model or from real measurements, which means that detailed physical modeling is avoided. It is easy to aggregate linear descriptions. Network solving is also a non-iterative procedure based on linear algebra, thus giving efficient calculations without convergence problems.

The goal of the proposed project is to construct analysis methods for the new model structure, to answer questions like: "How severe nonlinearities are allowed before the periodic nature of signals are destroyed?" and "How are disturbances attenuated?" An important issue is the risk for resonances. Resonances are important and serious disturbances that cause costly emergency stops and sometimes destroy equipment. It is non-trivial to assess the risk for resonances. One example is that the use of dynamic filters, introduced to prevent harmonic overtones, can actually increase the problems. The same issue has been raised by our international contacts at Adtranz and Daimler-Chrysler. Their research teams have shown great interest in our method and its potential application to resonance problems in train drives.

Applications

Apart from the applications of computer aided control there are several other application projects going on at the department, in robotics, real time control, fuzzy control, motion control, as well as control of processes in steel industry, biotechnology, and biomedicine.

Robotics

Researchers: Rolf Johansson, Anders Robertsson, and Klas Nilsson, Department of Computer Science, LTH

The laboratory for robotics and real-time systems is centered around an ABB Irb-6 robot and an ABB Irb-2000 robot. Hardware interfaces have been developed to create an open system suitable for control experiments. The computer hardware is VME-based with both micro processors and signal processors integrated into an embedded system for hard real-time control. The system is connected to a network with Sun workstations, which are used for program development and control design. The Robotics Laboratory is described in Chapter 3.

A purpose of the current project is to show how to organize open robot control systems and to verify these ideas by means of experiments. One goal is to permit efficient specification and generation of fast robot motions along a geometric path which requires coordinated adjustment of the individual joint motions. Another aspect of robot motion control is how to integrate simultaneous control of force and position according to ideas of impedance control in which stability is an important theoretical issue. A major topic in this project is to integrate aspects of control, sensor fusion, and application demands.

Another project is on the structure and programming of control systems for industrial robots. The problem addressed is how the software architecture and the real-time structure of a robot control system should be designed to allow easy and flexible incorporation of additional sensors and new control algorithms. A software layer between a supervisory sequence control layer and the basic control level has been proposed. Case studies and prototype experiments show promising results and further implementation is going on. A NUTEK-sponsored research program "Lund Research Programme in Autonomous Robotics" was continued

during the year. The program includes cooperation partners from the Division of Robotics of Mechanical Engineering, Department of Industrial Electrical Engineering and Automation, and industrial partners.

Real-Time Control

Researchers: Johan Eker, Anders Blomdell, Leif Andersson, and Karl-Erik Årzén

The on-going research project “Application specific real-time systems” studies real-time programming and real-time kernels/primitives. During 1998 the main focus of the project has been flexible environments for embedded systems.

The FRIEND language is the first step in developing a truly flexible and robust software platform for embedded control system. It is a continuation of the PÅLSJÖ/PAL project. The PÅLSJÖ environment provides a framework designed to support on-line configurations and code reuse. The control algorithm coding is made off-line and the system configuration is made on-line. The system may also be reconfigured on-line without stopping the system. The language PAL is a block based imperative language for implementation of embedded controllers. It is designed to support and simplify the coding of control algorithms. The language Friend is created by combining ideas from the PAL and the Simplex projects with contracts. The goal is to achieve a high degree of flexibility while still guaranteeing a fully functioning control system. The resources available for a control algorithm may change during execution and the controller and the run-time system in large, must adjust to these changes.

High-Level Grafcet for Supervisory Sequential Control

Researchers: Charlotta Johnsson and Karl-Erik Årzén

Sequential control is extremely important in industry both for continuous, discrete, and batch processes. It is needed both at the direct control level and for supervisory control applications.

During the last years Grafcet, or SFC (Sequential Function Charts), has emerged as an international standard for direct level sequential control, through the standards IEC 848 and IEC 1131-3. Grafcet, which

is a graphical programming language has been very well accepted in industry. However, today there is also an industrial need of a graphical programming language suited for sequential control at all control levels.

Grafcet has its roots in Petri Nets. In parallel to the development of Grafcet, High-Level Petri Nets have been developed from ordinary Petri Nets. High-Level Petri Nets combine the expression power of high-level programming languages with the formal specification language properties of Petri Nets while preserving the user-friendly graphical representation.

The goal of this project is to develop Grafcet into High-Level Grafcet and thereby make it amenable also to supervisory control applications. The work is based on Grafchart, a Grafcet toolbox developed at the department since 1991. The toolbox is implemented in G2, an object-oriented graphical programming environment. It has already been used in industry with great success. High-Level Grafchart is an extension to Grafchart that is currently under implementation. Grafchart is extended with object-oriented programming languages constructs and ideas from High-Level Petri Nets. The new features in High-Level Grafchart, compared with Grafcet, are procedure steps, process steps and exception transitions, parameterization, methods and message passing, object tokens and multi-dimensional charts.

This project focuses especially on batch control applications. In this context it is investigated how High-Level Grafchart can be used for recipe representation according to the recent standard, ISA-S88.01, for batch control. By using the features of High-Level Grafchart in various ways, recipes can be given different structures with different advantages and disadvantages. Since High-Level Grafchart is based on Grafcet, the recipes have a clear and intuitive syntax. The recipes can also be analyzed, with respect to deadlock situations, using the Petri net analysis methods. An on-line simulator of a multi-purpose, multi-path batch-cell has been developed and implemented in G2, see Figure 5.2, and is used as a test platform.

The project has an industrial steering and reference committee consisting of members from Alfa-Laval Automation, ABB Industrial Systems, Astra, Kabi Pharmacia, and van der Bergh Foods.

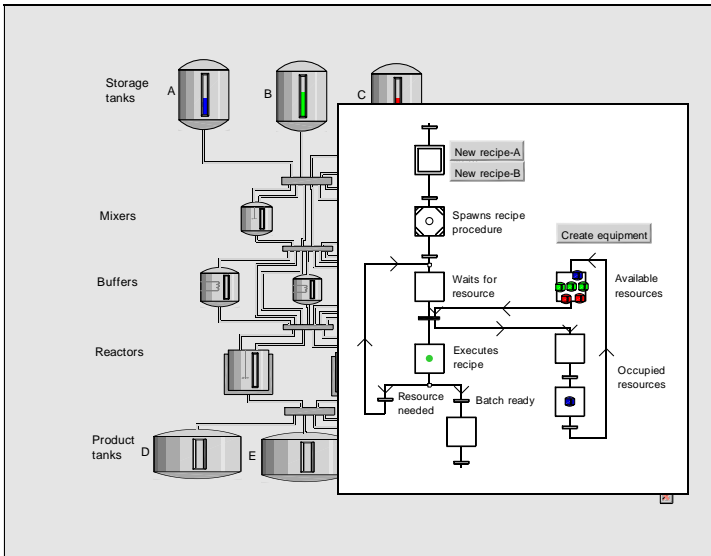

Figure 5.2 Batch process with recipe.

Fuzzy Algorithms for MIMO Control Systems

Researchers: Sven Hedlund, Mikael Johansson, Karl-Erik Årzén, and Anders Rantzer

FAMIMO (Fuzzy Algorithms for MIMO Control Systems) is a three year Esprit reactive long term research (LTR) project that started December 1, 1996. The project has four academic partners and one industrial partner, Siemens Automotive in Toulouse. The project is organized along two benchmark studies: control of a direct fuel injection engine and control of a wastewater fermentation process. Each partner will apply their favorite design method. The approach that is used in Lund is a heterogeneous, local controller approach, where fuzzy logic is used to implement interpolation.

During 1998 the work has been concentrated on the two benchmark applications. The engine control benchmark has been the focus of a PhD-level project course on control system design. A Matlab toolbox for analysis and synthesis of piecewise linear systems has been completed.

Motion Control

Researchers: Mattias Grundelius, Bo Bernhardsson, Karl Johan Åström, and Tore Hägglund

Motion control systems are common elements in manufacturing systems. They have a significant influence on quality and production capacity. Traditionally, motion control problems were solved with pure mechanical devices, but there are now many interesting alternatives that combine mechanical systems with different forms of motors and control systems. Such systems are typical cases where trade-off of control and process design is very important.

The focus in the project has been movement of open packages containing liquid. All packages in the machine follows the same acceleration profile. Between the filling station and the sealing station the package is moved one or several times. The aim is to find the acceleration profile that minimize the movement time with a maximum allowed slosh.

The problem is solved by first deriving a model of the slosh phenomenon and then applying optimal control techniques to calculate the acceleration profile. The modeling requires that the slosh can be measured. Several different methods to measure the slosh were tried before a satisfying method was found based on an infrared laser displacement sensor.

A simple slosh model has been derived. Both minimum-time and minimum-energy acceleration profiles have been calculated. The various acceleration profiles have been evaluated in the experimental setup with good results. Comparison with the acceleration profiles used in practice has also been done showing the advantage of the calculated acceleration profiles.

The project has resulted in Mattias Grundelius' licentiate thesis. The results have also been passed on to Tetra Pak and applied in their new packaging machines.

The project is funded by NUTEK under the REGINA program. It is performed in close collaboration with Tetra Pak Research & Development AB in Lund, who has supplied the experimental equipment.

Modeling and Control of Processes in the Steel Industry

Researchers: Lars Malcolm Pedersen and Björn Wittenmark

The research is focused on modeling and control of two main processes in the steel industry: a hot plate rolling mill and a slab rehear furnace. The work is carried out in cooperation with The Danish Steel Works Ltd. which delivers data and information about the processes while the research work is carried out at the Department of Automatic Control.

The work with the control of the hot rolling mill has been concentrated on deriving a multivariable nonlinear control algorithm for the control of plate thickness. The design of the control algorithm is based on a multivariable nonlinear model found using data collected from the hot rolling mill at The Danish Steel Works Ltd. We are currently working on implementation of a simplified version of the control law.

So far the work on furnace control has covered control of the slab temperature. Here a model for the slab temperature has been derived, the control problem has been formulated, and a nonlinear controller has been designed. The controllability and stability of the system has also been investigated. The slab temperature model is based on data the rehear furnace no. 2 at The Danish Steel Works Ltd. Future work includes verification of the control algorithm using FEM simulations.

Dynamic Modeling of an Ecocyclic Pulp Bleaching Plant

Researchers: Anna Delfin, Sven-Erik Mattsson, and Björn Wittenmark

Through the MISTRA project Ecocyclic Pulp Mill the department has been involved in a project on modeling of a bleaching plant. The project had, however, to be terminated when Anna Delfin left the department for a job outside the academia.

The intention with the project was to make a model of a future bleaching plant and to investigate the benefits from different bleaching strategies. Preliminary investigations and cooperation with Södra Cell in Mörrum show that the object-oriented modeling language Omola is very well suited for this kind of modeling. Only preliminary modeling work could be done in the project.

Robustness Analysis of the Scandinavian Power Network

Researchers: Anders Rantzer, Michael Lantz, and Lennart Andersson

The purpose of this project is to take advantage of recent computer tools for large scale robustness analysis, in order to analyse a dynamic model of the Scandinavian power transmission network.

The model includes 16 generators, 16 power loads, and 20 transmission lines. There are totally 16 inputs, 16 outputs, 127 states, and more than 500 parameters, see Figure 5.3. One objective is to compute the maximal range of parameter variations for which this equilibrium remains locally stable. Even if the number of uncertain parameters is restricted, the size of this problem is challenging.

Algorithms for structured singular value computations can handle matrices of dimension as high as 50–100, but not many problems of this size have been treated in the literature. One reason is that proper generation of input data for large problems is a non-trivial task. Our approach is the following: Using a large nonlinear differential-algebraic

Figure 5.3 A 16-generator model of the Scandinavian power network has been analyzed

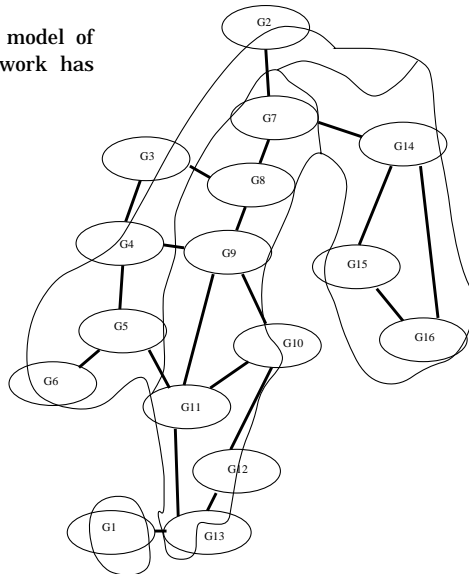

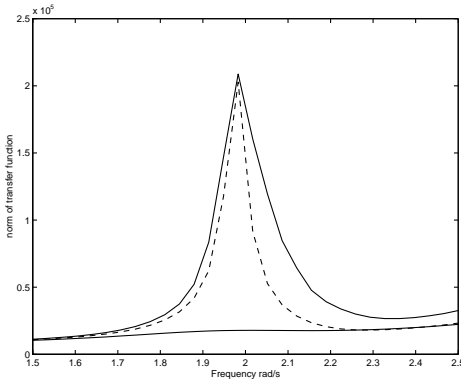

Figure 5.4 Input-output gain of 16 generator model. Nominal system gain – lower solid line. Worst case found – dashed line. Computed global bound – upper solid line.

model, a power system can be simulated and a stable equilibrium can be found. The system equations are then linearized symbolically and transformed into the format for robustness analysis in Matlab. Figure 5.4 shows some of the results that can be obtained with the method.

Our preliminary results are very encouraging and currently we are looking at improvements in several directions. One is to extend the analysis to a 32-node model, that has been developed by Svenska Kraftnät for educational purposes. Another is to make a more careful study of the sensitivity in the equilibrium point. The project is done in close contact with Sydkraft and the Department of Industrial Electronics and Automation at Lund Institute of Technology.

Timing Problems in Real-Time Systems

Researchers: Bo Bernhardsson, Johan Nilsson, and Björn Wittenmark

This is a subproject within the DICOSMOS project (Distributed Control of Safety Critical Mechanical Systems) supported by NUTEK. DICOSMOS is a cooperation between Department of Computer Engineering, CTH, Department of Mechanical Elements, KTH, and Department of Automatic Control, LTH.

The work in Lund has focused on analysis and design of control systems with communication delays. The results are presented in the PhD thesis by Johan Nilsson, “Real-Time Control Systems with Delays” (February

1998). Methods for analysis of stability and performance properties have been developed. A new optimal control scheme has been suggested and analyzed. The new scheme uses so called “time-stamping” of control and measurement messages. The optimal linear quadratic controller has been shown to have the separation property. We have also shown how to use the framework of so called jump linear systems to analyze random network delays, asynchronous loops, and sampling jitter. The problem with asynchronous loops has also been further investigated in a master thesis. The used network models have been verified by measurements on CAN and Ethernet buses.

Network delays, or network transfer times, have different characteristics depending on the network hardware and software. In a system with varying delays the normal assumptions on time invariance or periodicity is not true. The system is therefore harder to analyze. A Markov chain model has been developed to model dependence between time delays that are close in time. In the work it is shown how to analyze linear controllers, where the network delays are described such a Markov model. The Linear Quadratic Gaussian (LQG) optimal controller has been developed for this situation. The derived controller has a nice structure which makes it easy to implement. The optimal controller uses knowledge of the time delays. These can be calculated using “time-stamping” of messages in the network. The solution to the LQG-problem was found by combining an LQ-controller with a Kalman filter. It was shown that a separation principle holds, i.e., design of state feedback and state estimator can be done independently.

The developed theory has been tested in small examples. Controllers from the literature have been compared with the developed synthesis method. It is found that the developed control algorithm increases stability and performance of the control system.

Control of Biotechnology Processes

Researchers: Mats Åkesson and Per Hagander in cooperation with Jan Peter Axelsson, Pharmacia & Upjohn, and Olle Holst, Department of Biotechnology, Lund University

Large-scale production of many enzymes and pharmaceuticals can today be made using genetically modified microorganisms. In so called

bioreactors, living cells are grown to large numbers and then made to produce the desired substance. Fed-batch operation, where additional substrate is fed to the culture, is often a preferred way of production. To achieve reproducible cultivations with high cell densities and high productivity, it is important to design good strategies for the substrate-dosage control. A characteristic feature of biological processes is that many important process variables cannot be measured on-line, which complicates the design and realization of feedback strategies.

A project on substrate-dosage control of fed-batch units with genetically modified *E. coli* is performed on a contract with Pharmacia & Upjohn, Process R&D. Information of how to change the substrate feed rate is obtained from standard measurements by introducing controlled process perturbations. Only little process specific information is required, which makes this strategy well suited for new processes.

The control strategy has been implemented at the Department of Biotechnology, Lund University. Good cultivation conditions and high production levels could be obtained without prior knowledge of suitable feeding profiles. Further experiments are now performed in a collaboration with Active Biotech, Lund Research Center. The work is now also supported by NUTEK, and the control objectives are widened.

After a cultivation process, the product is recovered from the harvest broth. A common method for protein purification is ion exchange chromatography. During the spring a Master's project was performed investigating the modeling and control aspects based on data from the Pharmacia & Upjohn production plant in Strängnäs.

Biomedical Modeling and Control

Researchers: Rolf Johansson in cooperation with Måns Magnusson, Department of Oto-Rhino-Laryngology, Lund University Hospital

The project is directed towards assessment of normal and pathological human postural control. System identification and mathematical modeling of the dynamics in postural control are studied with special interest on adaptation, reflexive and anticipatory control. Reflexive and voluntary eye movements are studied in patients with lesions related to balance disorders. Experimental studies, with special reference to

the level of alertness, are undertaken to enhance understanding, diagnosis and treatment of dizziness and vertigo. A major complication is that human postural control is characterized by multi-sensory feedback control (visual, vestibular, proprioceptive feedback) and this fact is reflected both in experiment design and analysis. Special interest is directed to the importance of cervical and vestibular afference. To this purpose, stability properties are studied by means of induced perturbations specific to each sensory feedback loop by using system identification methodology. The work is supported by the Swedish Medical Research Council and the Faculty of Medicine, Lund University.

Cardiologic Analysis and Modeling

Researchers: Rolf Johansson in cooperation with Jonas Carlsson and S. Bertil Olsson, Department of Cardiology, Lund University Hospital

This project is directed towards chronic atrial fibrillation (CAF), one of the most common cardiac arrhythmias in man and associated with increased morbidity and mortality. Previous studies in animals have shown that experimental atrial fibrillation is based on different types of intra-atrial electrical re-entry. By exploring the activation of the right atrial free wall during open-heart surgery in patients with CAF and an underlying heart disease, we confirmed the presence of re-entry mechanisms. In addition, areas with organized activation were identified. The nature of the organized activation suggested re-entry in an anatomical structure, like the right annular bundle surrounding the tricuspid valve. In patients without signs of organized activation, multiple activation waves continuously re-enter due to functional properties of the atrial myocardium. An interesting result was that we failed to demonstrate that anisotropy in conduction velocity be a general property of the epicardial right atrial free wall of the intact human heart in patients with stable sinus rhythm as well as in patients with CAF.

Within this context, Dr Max Ingemansson received the Crafoord Prize for best Ph.D. dissertation 1998 of the Faculty of Medicine, Lund University.

6. External Contacts

The roles of the universities in technology transfer has recently been emphasized in Swedish research policy as the “the third mission” (tredje uppgiften). This means that we now also have responsibility for transfer of research to industry.

At present we have a healthy mixture of fundamental and applied work. The purpose of the theory activity is to develop new ideas, concepts and theories that capture the essence of real control problems. We are of course delighted to find applications of the theory but the focus is always on methodology. In the applications projects the goal is to solve real control problems together with external partners. In these projects the problems are approached with an open mind without glancing at particular methods. One purpose is to learn about real problems, another is to learn about new problems that are suitable for theoretical research. The applications projects also provide very good background for our educational activities.

Technology transfer takes many forms. One is to take results from our research and present them so that they are easy to use. Probably the best way to do this is through personal exchange between industry and university. Students are a very effective vehicle for the transfer.

Realizing that the majority of the research is done outside Sweden another important role for universities in a small country is to take existing knowledge and organize it in such a way that the results can easily be digested by engineers in industry. There is naturally a strong symbiosis with teaching in this activity. A good mechanism is thus to introduce new research material into existing and new courses. A related form of technology transfer is to write books and monographs and to develop software. We have been active in technology transfer for a long time, good examples of this type of exchange where we have transferred ideas are self-tuning control, automatic tuning and

External Contacts

computer-aided control engineering. More details have been presented in previous activity reports.

Industrial Contacts

We have very good working relations with several companies and organizations. The interaction are at many different levels and intensities, from visits and discussions to joint projects. Master theses and education are also important ingredients. This year we have made substantial efforts to increase the industrial interaction. During the year we have had major projects with

ABB Corporate Research,
ABB Power Systems
ABB Robotics
ABB SuHAB
Alfa Laval Automation,
The Danish Steel Works Ltd.,
Danfoss AS,
DDA Consulting,
Diana Control AB,
Dynasim AB,
Elforsk,
Gensym Corp.,
Pharmacia & Upjohn,
Sigma Exallon AB,
Siemens Automotive,
Sydkraft,
Tetra Pak Research & Development.

We have had smaller projects with

Active Biotech
Astra Draco,
Astra Hässle,
Alfa Laval Thermal,
Cellavision,

Comsol,
Ericsson,
Industrial Communications,
MEFOS,
Modo Paper Husum,
Novotek,
Pulp and Paper Industries Engineering Co. (STFI),
SIK – Institutet för livsmedel och bioteknik AB,
Södra Cell, Mörrums Bruk,
Vattenfall,
Volvo Technical Development,

and meetings and discussions with many other companies.

European Collaboration

We are a member of the ESPRIT project FAMIMO, *Fuzzy Algorithms for MIMO Control Systems*. The project has four academic partners and one industrial partner, Siemens Automotive in Toulouse (<http://iridia.ulb.ac.be/famimo/>).

We are also member of the ESPRIT longterm project *Heterogeneous Hybrid Control (H2C)* with three academic partners and DaimlerChrysler as an industrial partner (<http://www.control.lth.se/H2C/>).

Finally, we are members of the ESPRIT project *Tools for the Analysis of Hybrid Systems* together with VERIMAG, the Technical University of Denmark, and INRIA/IRISA.

7. Looking Back on Computer Aided Control Engineering

For several years we have had the tradition to give a perspective on older research projects. In this section we will discuss Computer Aided Control Engineering (CACE). This has been a major area of research at the Department since the 1970's, when key tools for simulation (Simnon), system identification (Idpac), and control design (Synpac and Polpac) were developed. The results were quite successful academically and industrially. Our results were transferred to industry where they were used extensively both nationally and internationally. An overview of this activity is given in [5]. The research project was terminated in 1980 because commercial tools started to appear and major technology changes were on the horizon.

In this section we will discuss research on CACE which started in 1985 and continued through 1998. After terminating our first CACE project in 1980 we followed the development closely. Around 1983 we found that the time was ripe for a new project because many tools that were needed such as high performance workstations, solvers for DAEs, software for symbolic manipulation were available. There were also interesting developments of computer aided engineering in other engineering fields. We carried out discussions with the program directors at STU (now called NUTEK). This was the time when research agencies had started to initiate larger more long range projects. Computer aided control engineering was therefore very timely. We had very useful discussions with STU which led to the formulation of the research program described in [6]. The project started in 1985 with one of our recent graduates Sven Erik Mattson as a project leader. We also had a good steering committee. The project was planned for five years. The plan called for a two year period with research covering a wide area. The intention was to select a particular project and focus on that for the last three years of the project.

There is a fairly complete documentation of the project in the planning documents [6, 18] and in many activity reports, in the special presentations to Swedish industry that were given about the projects [17], and in many papers. This project has resulted in the object-oriented modeling language Omola, its interactive simulation environment OmSim, and model libraries for thermal power generation. It has also contributed to the creation of the Modelica effort.

Pilot Projects

The following projects were investigated in the first phase of the project.

- Workstations and Graphics
- Symbolic Computations
- Intelligent User Interfaces
- High Level Languages for Problem Solving
- Implementation Languages

The results of the pilot projects are summarized in [18]. The usefulness of CACE depends critically on access to high performance workstations. An interesting perspective on the dramatic development was given by Dr. Hatfield of the Lawrence Livermore National Labs in his keynote address at the Second IEEE Control Systems Society Symposium on Computer-Aided Control System Design in 1985, where he discussed “recent developments in computer science and computer engineering with particular emphasis on computer graphics, a tool whose power is only beginning to be realized.” At the time there were workstations from SUN and Apollo with a capacity of 0.2 VAX. Dr Hatfield had a vision that an engineer in the very near future should have a 5M workstation, where 5M stood for 1 Mips, 1 Mbyte memory, 1 Mpixel display, Multi-tasking and 1 Mbyte/s network.

Special purpose hardware for graphics was available in 1985. The most advanced equipment was the 10 Mflop Geometry Engine in the Silicon Graphics Workstation. The project provided funding for a Silicon Graphics workstation in 1985. The machine was used to develop and implement a prototype simulator for dynamical systems based on Dymola. The system, called Hibliz, [12], permitted a user to scroll, pan,

and zoom the graphical system descriptions continuously in real-time. A unique feature was that the level of details changed when zooming.

The role of animation was explored in other projects. A program for 3D-animation of an ASEA robot was also developed. This way of representing the structure of a model and displaying simulation results was very well received. However, it required at that time too advanced a graphical hardware. Programs for CACE that were available around 1985 were merely tools for numerical computations. They did not support symbolic calculations. A pilot project for analysis of multi-variable linear systems [13], implemented in MACSYMA, clearly demonstrated the potential to do other things than number crunching. A prototype system for physical modeling which used extensive symbolic manipulation was also developed [7]. This system admitted extensive exploration of system structure and very high level system descriptions.

Ideas from artificial intelligence (AI), expert systems, and knowledge engineering were applied to construct an intelligent user interface for the interactive data analysis and system identification program Idpac. The system was completely non-invasive and used the previous command history to understand what the user was doing and gave help to this. This way of monitoring the user's activity was called the command spy strategy. Scripts were used for representing procedural knowledge, and production rules for diagnostic knowledge. Knowledge databases for frequency response analysis and system identification were developed. The results were very promising and showed that it is possible to construct a useful interface that incorporates much knowledge about theory and practice of system identification. However, another conclusion was that knowledge engineering demands a large effort, and thus a full knowledge database for system identification will not be constructed easily. The work is documented in the licentiate theses [15] and the journal paper [16] and several conference papers.

The work also gave useful insight into the requirements that should be imposed on CACE systems to admit construction of good user interfaces. An essential requirement is that the systems are sufficiently open. The results indicated clearly that there were many interesting possibilities

for substantial improvements of the user interfaces.

Several existing tools for CACE were investigated. It was shown that they could conveniently be described as high level problem solving languages. This approach gave a natural way to classify and extend the language.

A small study of implementation languages was also performed. The results of this study was that the future CACE systems would most likely be implemented using different tools. The advantages to start with rapid prototyping was also indicated.

The result of the pilot project are summarized in [18], among the particular results we can mention the dissertations [26, 2, 29, 4], software and many publications. There were intense discussions in the steering committee when it was time to choose an area for concentration in the last three years of the project. The major contenders were intelligent user interfaces for process modeling from experimental data and tools for physical modeling. In the end it was decided to concentrate on tools for physical modeling.

Modeling of Physical Systems

Modeling is a natural ingredient of all engineering fields. It is often restricted to specific domains. A particular feature of automatic control is that we are often faced with widely heterogeneous systems in a wide range of fields such as thermodynamics, mechanics, chemistry. The systems have to be treated uniformly in the same framework. Modeling typically takes about a quarter or a third of the effort in control system design. There are good computer tools for modeling in specific domains such as multi-body systems. There are very few tools that satisfy the needs for control engineers. The tools that are available have often grown out of tools from simulation.

Background

Our efforts also have their roots in simulators. The interactive simulator Simnon grew out of a master thesis by Hilding Elmqvist. Before

the system was transferred to a software house we distributed more than 2000 licenses to users in more than 40 countries. Version 3.0 of Simnon was shipped by SSPA, Gothenburg, in March 1999.

There were many demands for extensions of Simnon. Typical requests were to add data types and to allow hierarchical system descriptions. We started a small project to evaluate these demands and we expanded the investigation to explore the weaknesses of Simnon in general. We found that the most severe limitation for physical modeling lies in the block diagram paradigm which requires that the causality between inputs and outputs is assigned a priori. This is a very severe restriction which is obvious to anyone who has modeled electrical circuits. One consequence is that the block diagram paradigm cannot deal with the fact that state variables may be lost when systems are interconnected. To have more general modeling concepts it is necessary to replace the descriptions of sub-models in terms of ordinary differential equations (ODEs) by differential algebraic equations (DAEs). This will automatically deal with the difficulties that arise when states disappear due to interconnections of systems.

Instead of just making some extensions to Simnon we decided to make a more fundamental investigation of requirements of a language that would be suitable for modeling of physical systems. This resulted in the 1978 PhD dissertation by Hilding Elmqvist called, *A Structured Model Language for Large Continuous Systems*, see [11] and an implementation called Dymola. This system permitted modeling of large systems based on DAEs. The system had language constructs to describe sub-models in a form close to physics and advanced constructs to describe interconnections. To have efficiency it is, however, necessary to use symbolic manipulation extensively. Dymola was strongly influenced by the first object-oriented language Simula. Graph theoretical methods were used for causality analysis sorting and to detect algebraic loops. Dymola introduced model classes, which at the time were called model types. However, there were no inheritance concept in Dymola.

We strongly believed in the ideas of Dymola, but we made the assessment that time was not ripe for a system of this type, partially due to the lack of good platforms for object oriented programming and

partly due to the lack of good solvers for DAEs. The computers available to us in 1978 were not powerful enough for this task. Our efforts on languages for modeling of physical systems were therefore put on hold.

Omola

Around 1986 time was ripe for a new attempt to develop languages for physical modeling. The project leader was Sven Erik Mattson, two PhD students Mats Andersson and Bernt Nilsson, several staff members and and visiting computer scientist Wolfgang Kreutzer contributed actively to the project. The research focussed initially on model structuring and we investigated the possibilities to exploit object-orientation more thoroughly. Lisp was used in the first prototypes and experiments, see [7], but it was soon realized that a specially designed language for object-oriented model representation would be useful and we switched to Common Lisp and KEE.

The first version of the object-oriented modeling language Omola was ready in 1988, see [1, 2]. We found it useful to view the basic structuring unit model as consisting of three parts: terminals, parameters, and realizations, which also are classes. The terminals are variables which constitute a well-defined interface to describe interactions with the environment. Parameters are interface variables defined by the model designer to allow the user to adapt the description of behavior. Models can be decomposed hierarchically with well defined interfaces that describe interaction. Omola allows models and model components to be defined as specializations of previously defined models by using the inheritance concept adopted from object-oriented programming. System behavior was described in terms of DAE systems.

OmSim

The prototype implementation was received very well and we got funding to continue. To see the full power of the technique it was decided to program the simulator in C++. To avoid large programming effort we made use of a public domain C++ class library InterViews from Stanford. It is built upon X-Windows, which means that OmSim has to run under Unix or some of its dialects such as Linux. OmSim uses a set of various packages for numerical integration and equation

solving. The graphical user interface was implemented by Dag Brück and later improved by Tomas Schönthal. Mats Andersson was responsible for the internal representation and handling of models classes. Sven Erik Mattsson developed and implemented the symbolic manipulation and generation of efficient simulation code. Tomas Schönthal wrote the simulation engine. The result was an interactive environment for model development and simulation called OmSim (Omola Simulation Environment). It includes a graphical model editor, consistency analysis, symbolic manipulation, ODE and DAE solvers, and interactive plotting. Major presentations of Omola and OmSim were first given at the 1992 IEEE Symposium on Computer Aided Control System Design. Five papers on Omola, Omsim, and applications were presented [21, 3, 24, 19, 28]. OmSim is described in [22, 23, 4] and URL: <http://www.control.lth.se/~cace>. Versions are maintained for Sun and HP workstations under X Windows System or PCs running Linux. They are available via anonymous FTP and the web WWW. The usefulness has been demonstrated in a number of application projects. More than hundred groups have taken copies of OmSim.

Omola was also extended to support modeling of hybrid systems. Besides support of behavioral descriptions in terms of DAE systems and difference equations, Omola has primitives for describing discrete events which allows definition of classes to support high level descriptions as finite state machines and Petri nets.

The modeling paradigm requires extensive symbolic manipulation in order to yield reasonably efficient simulations. Much effort has been devoted to develop efficient methods for translating the model to simulation code. Originally we intended to use standard software for computer algebra such as Macsyma, Maple, or Mathematica. These tools support advanced manipulation of relatively small problems. In the context of object-oriented modeling we are speaking of thousands or even hundred thousands of equations but many manipulations are very simple. The aim of the manipulation is to reduce the size and the complexity of the problem to be solved numerically. A numerical DAE solver discretizes the problem into an algebraic equation problem. If there are n unknowns, the effort to solve for them is proportional to n^α , where α typically is 2–3. It is therefore important to reduce the

size of the problem. Connections typically give rise to trivial equations of the type $v_1 = v_2$, which are very easy to reduce. It was therefore decided to include tailor made code for the algebraic manipulations. Extensive graph theoretic methods were used to decompose the problem into a sequence of simpler problems. A description of the symbolic manipulation done by OmSim is given in [23]. Solution of DAE problems may involve both integration and differentiation. Symbolic methods are used to perform the differentiation, selection of states is done by combining symbolic and numeric methods [25].

Hybrid Systems

Our modeling approach is very well suited to deal with hybrid systems which are handled very poorly by conventional simulators. This was given particular attention in the thesis [4]. It was very rewarding to see that the very general framework for hybrid control developed by Branicky could be implemented in Omola/OmSim in a about a month, see [9]. Difficult problems involving chattering and relays were also investigated. A particular method which detects that chattering occurs and which generates Filippov solutions automatically is described in [20]. The system was also used for some very delicate simulations involving higher order chattering, see [14].

Applications

A number of applications have been carried out concurrently with the development of Omola and OmSim. They have given very useful feedback on the development of the tools. The expression power of OmSim was investigated by modeling large complex chemical processes [27, 26, 29]. This work resulted in guidelines for structure and class hierarchy decomposition and organization of model libraries. Issues relating to component composition versus multiple inheritance were also raised. Language extensions were suggested. Typical examples are constructs for system structuring using arrays of components and language elements to define regular connection patterns. It is useful for modeling of a distillation column which consists of a set of trays connected in series. Component arrays are also useful for spatial discretization. Medium and machine decomposition was also proposed as a method to separate the description of the process media

from processing units. This can be done by allowing model classes to be parameters. Arrays of model components and model classes as parameters were never to be supported by OmSim.

A library for modeling thermal power generation was developed in close collaboration with Sydkraft [30, 10]. It has been used to model and simulate the combined cycle power plant in Värnamo, Sweden. Sydkraft Konsult AB explored the possibilities to use the models and object-oriented modeling in their daily work. The general conclusion was that the object-oriented modeling methodology has a great potential to improve the productivity at design of new plants drastically, but that problems remain before it can be used more routinely. The new approach makes it possible to distribute and support use of simulation to that extent that a trained user can put models together and use simulation in his daily work. Sometimes, he may need to consult experts on modeling and simulation. SYCON (former Sydkraft Konsult AB) are now continuing their work to make a model library of high industrial and commercial standard.

Modeling of electrical transmission networks [19] was an early and very successful application. A model library with components for generators, busses, lines, and loads to simulate the behavior at short-circuits disconnections of lines and load changes was developed. A 16-machine model of the Nordic transmission network was put together and simulated. Results obtained agreed very well with results obtained from a highly specialized commercial system for power system simulation.

Omola has been used extensively for masters theses in modeling and simulation. It was very useful to new users of the system. It was also useful to model systems of widely different character. Among the applications we can mention heat exchanger units for Alfa-Laval Thermal, towed sonar arrays (a 500–1000 m long submarine cable equipped with microphones towed by a ship or submarine) for Kockums Submarine Systems, and continuous juice blending for Tetra Pak.

Technology Transfer

Our early CACE programs were developed to the stage that we could distribute commercial software. Because of the increasing complexity

Looking Back on CACE

of the software, it was decided from the beginning that it was not appropriate for us to develop software of commercial quality. Instead we have developed prototypes and published our results in the regular academic channels. We have also made executable software available on the web.

We were, however, also looking into other mechanism for technology transfer. There was an interesting opportunity in 1992 when Hilding Elmqvist founded Dynasim AB in Lund. The company was originally based on commercialization of Dymola. It is interesting that work based on a PhD dissertation from 1978 could be commercialized in 1992. It was very interesting for the CACE project to have a local company with highly competent staff in an area close to our own interest and was very natural to start a collaboration. A first step in technology transfer was that Dynasim hired one of our programmers, Dag Brück. He came to Dynasim in 1993 with extensive experience in graphics programming and use of C++. Dynasim developed extremely efficient simulators and we started discussions about merging Dymola and Omola. Merging of the ideas was actually done in a larger context by forming the Modelica Design Group (see below). The next step was that our project leader Sven Erik Mattson joined Dynasim in 1998. The collaboration with Dynasim AB has been very fruitful and we have formed a consortium (see URL: <http://www.dynasim.se/consort.html>) to promote object-oriented modeling.

We have had a very stimulating exchange of ideas of how to use object oriented modeling with Sydkraft Konsult. This has influenced both the design of the software and has greatly enhanced our knowledge of industrial applications. The fact that OmSim is available by anonymous FTP has given a unique possibility to interact with many users. A global study of research projects on tools for physical modeling was made by Honeywell and Exxon in 1991. A result of this was that teams from MIT, CMU, Aachen, and LTH were invited to a meeting to discuss future collaboration.

Modelica

From the start of the project in 1985 we have had a vision of a unified modeling language for modeling of physical systems. This vision

was strengthened in our discussions with Dynasim and other research groups in Europe with similar ideas. A core group had been formed consisting of Hilding Elmqvist of Dynasim, Sven Erik Mattsson, LTH, Per Sahlin, Bris Data, Stocholm, and Martin Otter, DLR, Germany. A first meeting with representation also from Gas de France was held in Lund in September 2–4, 1996. A unique opportunity arose in connection with a workshop on Modeling of Complex Systems, [8], that we organized for the ESF program on Control of Complex Systems (<http://www.esf.org/pp/COSYa.htm>) September 5–7, 1996. We had the opportunity to invite researchers from the leading groups in Europe to Lund. The idea to design a unified object-oriented modeling language got a very good response and the group that was later named the Modelica Design Group (<http://www.Modelica.org>) expanded. Because of the Modelica activity and the collaboration with Dynasim we can focus on more fundamental problems and still have access to software with the desirable features.

Summary

The research on computer aided control engineering (CACE) has been a major activity at the department for a long time. It has been demonstrated that the engineering effort required to solve control problems can be drastically reduced by proper tools. There has been a very dynamic development because of the drastic increases in computing power. Much of our results in terms of ideas and software have been transferred to industry. The present activity on Modelica has a great potential.

CACE References

- [1] M. Andersson. “An object-oriented modeling environment.” In Iazeolla *et al.*, Eds., *Simulation Methodologies, Languages and Architectures and AI and Graphics for Simulation*, 1989 European Simulation Multiconference, Rome, pp. 77–82. The Society for Computer Simulation International, 1989.
- [2] M. Andersson. *Omola—An Object-Oriented Language for Model Representation*. Lic Tech thesis TFRT-3208, Department of Automatic Control, Lund Institute of Technology, Lund, Sweden, May 1990.
- [3] M. Andersson. “Discrete event modelling and simulation in Omola.” In *Proceedings of the 1992 IEEE Symposium on Computer-Aided Control System Design, CADCS '92*, Napa, California, March 1992.
- [4] M. Andersson. *Object-Oriented Modeling and Simulation of Hybrid Systems*. PhD thesis ISRN LUTFD2/TFRT-1043--SE, Department of Automatic Control, Lund Institute of Technology, Lund, Sweden, December 1994.
- [5] K. J. Åström. “Computer aided modeling, analysis and design of control systems—A survey.” *IEEE Control Systems Magazine*, **3:2**, pp. 4–16, 1983.
- [6] K. J. Åström and O. Berkefelt. “Computer aided control engineering.” Technical Report, National Swedish Board of Technical Development (STU), Stockholm, Sweden, 1983.
- [7] K. J. Åström and W. Kreutzer. “System representations.” In *Proc. IEEE Control Systems Society Third Symposium on Computer-Aided Control Systems Design (CACSD)*, Arlington, Virginia, 1986.
- [8] K. J. Åström, W. Schaufelberger, S. E. Mattsson, and J. Eborn. “COSY workshop, mathematical modeling of complex systems.” Report ISRN LUTFD2/TFRT-7551--SE, Department of Automatic Control, Lund Institute of Technology, Lund, Sweden, September 1996.
- [9] M. S. Branicky and S. E. Mattsson. “Simulation of hybrid systems.” In Antsaklis *et al.*, Eds., *Hybrid Systems IV*, Lecture Notes in Computer Science, Vol. 1273, pp. 31–56. Springer Computer Science, July 1997.
- [10] J. Eborn. *Modelling and Simulation of Thermal Power Plants*. Lic Tech thesis ISRN LUTFD2/TFRT-3219--SE, Department of Automatic Control, Lund Institute of Technology, Lund, Sweden, February 1998.

- [11] H. Elmqvist. *A Structured Model Language for Large Continuous Systems*. PhD thesis TFRT-1015, Department of Automatic Control, Lund Institute of Technology, Lund, Sweden, May 1978.
- [12] H. Elmqvist and S. E. Mattsson. "A simulator for dynamical systems using graphics and equations for modelling." *IEEE Control Systems Magazine*, **9:1**, pp. 53–58, 1989.
- [13] U. Holmberg, M. Lilja, and B. Mårtensson. "Integrating different symbolic and numeric tools for linear algebra and linear systems analysis." In *SIAM Conference on Linear Algebra in Signals, Systems and Control*, Boston, Massachusetts, 1986.
- [14] K. H. Johansson, A. Rantzer, and K. J. Åström. "Fast switches in relay feedback systems." *Automatica*, **35:4**, pp. 539–552, April 1999.
- [15] J. E. Larsson and P. Persson. *An Expert System Interface for Idpac*. Lic Tech thesis TFRT-3184, Department of Automatic Control, Lund Institute of Technology, Lund, Sweden, March 1987.
- [16] J. E. Larsson and P. Persson. "An expert system interface for an identification program." *Automatica*, **27**, pp. 919–930, 1991.
- [17] S. E. Mattsson, Ed. "Computer aided control engineering CACE (Proceedings of a full-day seminar in Stockholm, March 25, 1987)." Report TFRT-7359, Department of Automatic Control, Lund Institute of Technology, Lund, Sweden, May 1987.
- [18] S. E. Mattsson, Ed. "Programplan för ramprogrammet 'Datorbaserade hjälpmedel för utveckling av styrsystem'," (Plan for the project 'Computer aided control engineering, CACE'). Report TFRT-3193, Department of Automatic Control, Lund Institute of Technology, Lund, Sweden, June 1987.
- [19] S. E. Mattsson. "Modelling of power systems in Omola for transient stability studies." In *Proceedings of the 1992 IEEE Symposium on Computer-Aided Control System Design, CADCS '92*, Napa, California, March 1992.
- [20] S. E. Mattsson. "On object-oriented modeling of relays and sliding mode behaviour." In *IFAC'96, Preprints 13th World Congress of IFAC*, vol. F, pp. 259–264, San Francisco, California, July 1996.
- [21] S. E. Mattsson and M. Andersson. "The ideas behind Omola." In *Proceedings of the 1992 IEEE Symposium on Computer-Aided Control System Design, CACSD '92*, Napa, California, March 1992.

- [22] S. E. Mattsson and M. Andersson. "Omola—An object-oriented modeling language." In Jamshidi and Herget, Eds., *Recent Advances in Computer-Aided Control Systems Engineering*, vol. 9 of *Studies in Automation and Control*. Elsevier Science Publishers, 1993.
- [23] S. E. Mattsson, M. Andersson, and K. J. Åström. "Object-oriented modelling and simulation." In Linkens, Ed., *CAD for Control Systems*, chapter 2, pp. 31–69. Marcel Dekker, Inc, New York, 1993.
- [24] S. E. Mattsson and G. Söderlind. "A new technique for solving high-index differential-algebraic equations." In *Proceedings of the 1992 IEEE Symposium on Computer-Aided Control System Design, CACSD '92*, Napa, California, March 1992.
- [25] S. E. Mattsson and G. Söderlind. "Index reduction in differential-algebraic equations using dummy derivatives." *SIAM Journal of Scientific and Statistical Computing*, **14:3**, pp. 677–692, 1993.
- [26] B. Nilsson. *Structured Modelling of Chemical Processes—An Object-Oriented Approach*. Lic Tech thesis TFRT-3203, Department of Automatic Control, Lund Institute of Technology, Lund, Sweden, September 1989.
- [27] B. Nilsson. "Structured modelling of chemical processes with control systems." In *Annual AIChE Meeting 1989*, San Francisco, California, 1989.
- [28] B. Nilsson. "Object-oriented chemical process modelling in Omola." In *Proceedings of the 1992 IEEE Symposium on Computer-Aided Control System Design, CADCS '92*, Napa, California, March 1992.
- [29] B. Nilsson. *Object-Oriented Modeling of Chemical Processes*. PhD thesis ISRN LUTFD2/TFRT--1041--SE, Department of Automatic Control, Lund Institute of Technology, Lund, Sweden, August 1993.
- [30] B. Nilsson and J. Eborn. "An object-oriented model database for thermal power plants." In Breiteneker and Husinsky, Eds., *Eurosim '95 Simulation Congress*, pp. 747–752. Elsevier, September 1995.

8. Dissertations

Two PhD theses were defended: Johan Nilsson and Jörgen Malmborg; and six Lic Tech theses were completed: Mats Åkesson, Jonas Eborn, Mattias Grundelius, Erik Möllerstedt, Martin Öhman, and Hélène Panagopoulos.

The abstracts are presented here in chronological order.

Modelling and Simulation of Thermal Power Plants

Jonas Eborn

Lic Tech dissertation, presented on February 2, 1998



Mathematical modelling and simulation are important tools when dealing with engineering systems that today are becoming increasingly more complex. Integrated production and recycling of materials are trends that give rise to heterogenous systems, which are difficult to handle within one area of expertise.

Model libraries are an excellent way to package engineering knowledge of systems and units to be reused by those who are not experts in modelling.

Many commercial packages provide good model libraries, but they are usually domain-specific and closed. Heterogenous, multi-domain systems requires open model libraries written in general purpose modelling languages.

This thesis describes a model database for thermal power plants written in the object-oriented modelling language OMOLA. The models are based on first principles. Subunits describe volumes with pressure and enthalpy dynamics and flows of heat or different media. The subunits are used to build basic units such as pumps, valves and heat exchangers which can be used to build system models. Several applications are described; a heat recovery steam generator, equipment

for juice blending, steam generation in a sulphuric acid plant and a condensing steam plate heat exchanger.

Model libraries for industrial use must be validated against measured data. The thesis describes how parameter estimation methods can be used for model validation. Results from a case-study on parameter optimization of a non-linear drum boiler model show how the technique can be used.

Real-Time Control Systems with Delays

Johan Nilsson

PhD dissertation, presented on February 11, 1998

Opponent: Prof Torsten Söderström, Uppsala University, Sweden. Committee: Prof Anders Lindquist, Stockholm; Prof George Lindgren, Lund; Dr Per Erik Modén, ABB Corporate Research, Västerås.



Control loops that are closed over a communication network get more and more common. A problem with such systems is that the transfer delays will be varying with different characteristics depending on the network hardware and software. The network delays are typically varying due to varying network load, scheduling policies in the network and the nodes, and due to network failures. Two network models of different complexity are studied:

- Random delays that are independent from transfer to transfer,
- Random delays with probability distribution functions governed by an underlying Markov chain.

The delay models are verified by experimental measurements of network delays.

In the thesis it is shown how to analyze stability and expected performance of linear controllers where the network delays are described by one of the two network models above. Methods to evaluate quadratic

cost functions are developed. Through the same analysis we find criteria for mean square stability of the closed loop for the different network models.

The Linear Quadratic Gaussian (LQG) optimal controller is developed for the two delay models. The derived controller uses knowledge of old time delays. These can be calculated using “timestamping” of messages in the network. “Timestamping” means that every transferred signal is marked with the time of generation. The receiving node can then calculate how long the transfer delay was by comparing the timestamp with the internal clock of the node.

A Probing Strategy for Substrate Feeding in *Escherichia coli*

Mats Åkesson

Lic Tech dissertation, presented on March 23, 1998

Large-scale production of many proteins can today be made using genetically modified microorganisms. One of the most frequently used host organisms is the bacterium *Escherichia coli*. A problem encountered during cultivations of *E. coli* is the accumulation of the by-product acetate, which tends to reduce growth and protein production. Formation of acetate can be avoided by a proper substrate feeding strategy, but most strategies require considerable process knowledge to work well. The main problem is that many important process variables cannot be measured on-line, which complicates the design and realization of a feedback strategy.



This thesis presents a novel feedback strategy for substrate feeding in cultivations of *E. coli*. The key idea is to exploit a characteristic change in the cell metabolism at the onset of acetate formation. By superimposing short pulses in the substrate feed rate, on-line detection of acetate formation can be made using a standard dissolved oxygen sensor. Several experiments confirm the validity of this detection method.

A simple feedback algorithm is used to adjust the feed rate to avoid acetate formation while maintaining a high cell growth rate. The feasibility of the feeding strategy is demonstrated by simulations and tuning rules that require a minimum of process specific information are derived.

The feeding strategy requires good control of the concentration of dissolved oxygen. Variations in oxygen dynamics during a cultivation may cause problems if a controller with fixed parameters is used. A control approach based on PID control and gain scheduling from the stirrer speed is suggested.

An Aggregated Approach to Harmonic Modelling of Loads in Power Distribution Networks

Erik Möllerstedt

Lic Tech dissertation, presented on April 16, 1998

The increasing number of power electronic devices result in harmonic distortion, which leads to losses, overheating, and malfunction. However, power electronics can also be used for harmonic mitigation. This brings up the need for methods to model and analyze networks with nonlinear and switching components.

This thesis addresses a major difficulty associated with simulation of distribution networks, the huge number of components. Model reduction is essential in order to avoid too complex models. The harmonic Norton equivalent, a load model structure that supports aggregation of nonlinear loads, is presented. It describes a linearized relation between voltage spectrum and current spectrum. It is a frequency domain description valid for steady-state harmonic analysis. The linearization is justified by the limited amount of distortion that is allowed in distribution systems. Nonlinear networks are solved using linear algebra, avoiding iterative methods, and thus any convergence problems.



To avoid detailed modelling of the networks, there is a need for methods to estimate the parameters of low order aggregated models. The structure of the harmonic Norton equivalent reveals how parameter estimation of aggregated models should be performed. A procedure for obtaining the equivalents from measurements is presented and shows good agreement with the validation data.

Analysis and Design of Hybrid Control Systems

Jörgen Malmberg

PhD dissertation, presented on May 28, 1998

Opponent: Prof Shankar Sastry, University of California at Berkeley. Committee: Prof Jakob Stoustrup, Lyngby, Denmark; Prof Torkel Glad, Linköping; Ass Prof Michael Branicky, Cleveland, Ohio.



Different aspects of hybrid control systems are treated: analysis, simulation, design, and implementation.

A systematic methodology using extended Lyapunov theory for design of hybrid systems is developed. The methodology is based on conventional control designs in separate regions together with a switching strategy.

Dynamics are not well defined if the control design methods lead to fast mode switching. The dynamics depend on the salient features of the implementation of the mode switches. A theorem for the stability of second order switching together with the resulting dynamics is derived. The dynamics on an intersection of two sliding sets are defined for two relays working on different time scales.

The current simulation packages have problems modeling and simulating hybrid systems. It is shown how fast mode switches can be found before or during simulation. The necessary analysis work is a very small overhead for a modern simulation tool.

To get some experience from practical problems with hybrid control the switching strategy is implemented in two different software environments. In one of them a time-optimal controller is added to an existing PID controller on a commercial control system. Successful experiments with this hybrid controller shows the practical use of the method.

Trajectory-Based Model Reduction of Nonlinear Systems

Martin Öhman

Lic Tech dissertation, presented on October 9, 1998



The first part of this thesis concerns model reduction of nonlinear models. Physical insight in a model can be used to indicate which parts of the model that can be reduced. Based on linearization around specific trajectories, a systematic procedure is suggested to estimate the error caused by reduction. Optimization is used to adjust parameters in a reduced model to minimize the error. This is applied to two examples.

The first example is an inverted pendulum connected to a rotating beam. It is shown that, for a swing-up trajectory the pendulum can be quite well approximated by a pendulum on a cart. The second example is a drum boiler, modeled with a second order as well as a fourth order model. For an experimental trajectory it is possible to reduce large parts of the model, adjust the remaining parameters, and get a model almost as correct as the original one.

The procedures discussed above to estimate error involve approximations. Ideas are also presented in this thesis about how to find a strict upper bound for the error. The Small Gain Theorem is used on the Taylor expansion of the error.

The second part of the thesis contains the paper *Implementation aspects of the PLC standard IEC 1131-3*. IEC 1131-3 is a standard for PLCs defining four programming languages and a type of Grafcet, Sequential Function Charts (SFC). An object oriented prototype of SFC and the language Function Block Diagram has been implemented. Various

execution methods are discussed. Algorithms for local and global sorting are implemented and evaluated. The standard is found to be unclear in some parts.

Motion Control of Open Containers with Slosh Constraints

Mattias Grundelius

Lic Tech dissertation, presented on November 20, 1998

This thesis considers liquid motion within moving open containers. The problem is to determine the open-loop acceleration profile for moving the container in minimum time without excessive slosh. This very common problem in the packaging industry has a significant influence on production capacity and quality.



Traditionally, motion control problems were solved with purely mechanical devices. The introduction of modern servo systems to control movement has increased the flexibility and it is now possible to use different acceleration profiles for different products. Since the fluid dynamics of different products are very different (for example compare skim milk with yoghurt) they have different optimal acceleration profiles. This has led to an increased interest in systematic methods for calculation of acceleration profiles.

The problem was solved by deriving a simple model of the slosh and then applying optimal control techniques to calculate the acceleration profiles. Experiments showed that slosh exhibits two nonlinear behaviors: amplitude dependent oscillation frequency and asymmetric oscillation. The surface elevation was measured with an infrared laser displacement sensor. A linear second order oscillator was used to model the slosh. The acceleration profiles were calculated by solving different optimal control problems both numerically and analytically. The performances of the obtained acceleration strategies were evaluated in experiments.

The experiments show that the acceleration profiles calculated by solving a minimum-energy problem give the best performance. The minimum-time strategy fails due to low model accuracy. The measurement problem proved to be hard and several different methods were investigated, before a working method was found.

PID Controller Design

Hélène Panagopoulos

Lic Tech dissertation, presented on December 9, 1998

The PID controller is the most commonly used control algorithm today. In spite of its wide-spread use there exist no generally accepted design method. There are several reasons to look for better methods to design PID controllers. One reason is the significant impact it may give because of the wide-spread use of the controllers. Another reason is the significant benefit improved design methods will give emerging auto tuners and tuning devices.



This thesis presents two new design methods: one for PI controllers and one for PID controllers. Also, a number of considerations in PID controller design are discussed.

To begin with the two design methods are presented. The specifications capture demands on load disturbances rejection, set point response, measurement noise, and model uncertainty. The primary design goal is to obtain good load disturbance responses. This is done by minimizing the integrated error, IE . Robustness is guaranteed by requiring that the maximum sensitivity is less than a specified value. Good set point response is obtained by using a structure with two degrees of freedom. Measurement noise is dealt with by filtering. The design procedures have been applied to a variety of systems. The thesis ends by showing how the the two design methods for PI and PID control establish a nice connection with H_∞ control.

9. Honors and Awards

Karl Johan Åström was given the *honorary degree as Doctor of Engineering* at University of Glasgow in June 1998.

Karl Johan Åström received the *Distinguished Member Award* from IEEE Control Systems Society in recognition of his “exceptional service to the Society and to the profession,” in December 1998.

Rolf Braun and **Per Hagander** received awards for “*nit och redlighet i rikets tjänst*” (*zealous and devoted service*), that is, they have been employed by the government for 30 years. This year the award was given to 108 employees at Lund University.

Karl Henrik Johansson received a post-doctoral research grant from the Swedish Foundation for International Cooperation in Research and Higher Education to work at Department of Electrical Engineering and Computer Sciences, University of California, Berkeley.

Karl Henrik Johansson was given the *Best Paper in Session Prize* for his contribution “A Multivariable Laboratory Process with an Adjustable Zero” at the 17th American Control Conference in Philadelphia, Pennsylvania, USA, June 1998.

Anders Rantzer was awarded a six year senior research position by the Swedish Natural Science Research Council (NFR).

Jan Sternby won the *1998 Transactions on Control Systems Technology Best Paper Award* for his paper “Adaptive Control of Ultrafiltration,” presented in *Trans. on Control Systems Technology*, **4:1**, January 1996. The award was announced in December at the 1998 CDC conference in Tampa, Florida.

10. Personnel and Visitors

Personnel

During 1998 the following persons have been employed at the department. The list shows the *status of December 1998* if nothing else is mentioned.

Professors

Karl Johan Åström
Per Hagander (biträdande)
Jan Sternby (adjungerad 20 %)
Björn Wittenmark

Associate Professors

Karl-Erik Årzén
Tore Hägglund
Rolf Johansson
Anders Rantzer

Research Associates

Bo Bernhardsson
Karl Henrik Johansson (*until August 31*)
Sven Erik Mattsson (*until July 31*)

Research Engineers

Leif Andersson
Anders Blomdell
Rolf Braun
Tomas Schönthal (*until August 23*)

Personnel and Visitors

PhD Students

Lennart Andersson
Anton Cervin (*from May 1*)
Anna Delfin (*until April 21*)
Jonas Eborn
Johan Eker
Mattias Grundelius
Magnus Gäfvert
Sven Hedlund
Ari Ingimundarson (*from November 1*)
Mikael Johansson
Charlotta Johnsson
Jörgen Malmberg (*until June 14*)
Erik Möllerstedt
Johan Nilsson (*until August 14*)
Hélène Panagopoulos
Mikael Petersson
Anders Robertsson
Lars Malmcolm Pedersen
Hubertus Tummescheit (*from July 1*)
Anders Wallén
Mats Åkesson
Martin Öhman (*until November 7*)

Secretaries

Eva Dagnegård
Britt-Marie Mårtensson
Eva Schildt
Agneta Tuszyński (part time)

Visiting Scientists

The following researchers have stayed with the department for a couple of days by the least.

Henrik Olsson *Feb 9–13, 1998*

Daimler-Benz, Berlin, Germany

Liankui Dai *Sep 1, 1997 – May 31, 1998*

Zhejiang University, Hangzhou, P.R. China

Jan Komorowski *Sep 1, 1997 – April 30, 1998*

Norwegian University of Science and Technology, Trondheim,
Norway

Keith Glover *May 4–6, 1998*

University of Cambridge, UK

Glenn Vinnicombe *May 4–8, 1998*

University of Cambridge, UK

Michael Branicky *May 19 – June 4, 1998*

Case Western Reserve Univeristy, Cleveland, Ohio, USA

Sandor Veres *June 19 – Sep 13, 1998*

University of Birmingham, UK

Alexander Megretski *Aug 3–9, 1998*

MIT, Cambridge, Massachusetts, USA

Anuradha Annaswamy *Aug 17–20, 1998*

MIT, Cambridge, Massachusetts, USA

Rodney Bell *Aug 1 – Sep 3, 1998*

Macquarie University, New South Wales, Australia

Laurent Praly *Sep 20 – Oct 3, 1998*

Ecole des Mines de Paris, France

Andrey Ghulchak *From Sep 14, 1998*

Mathematical and Mechanical Faculty, St Petersburg State
University, St Petersburg, Russia

Visiting Students

The following foreign students have stayed with the department and followed the courses. Many of them have made their master's theses. Students marked with "(S)" are from the SOCRATES program, "(B)" are from bilateral agreement, and "(P)" are PhD students.

Martin Rentsch (B) *Oct 27, 1997 – March 25, 1998*

Universita di Roma "La Sapienza",
Dipartimento di Informatica e Sistemistica, Rome, Italy

Ben Bastian (B) *Dec 1, 1997 – March 28, 1998*

University of Newcastle, Australia

Lorenzo Bigagli (S) *Jan 21 – July 31, 1998*

University of Florence, Italy

Gabriele Nardini (S) *Jan 19 – July 31, 1998*

University of Florence, Italy

Hubertus Tummescheit *Feb 1 – June 30, 1998*

DLR, Köln, Germany

Michael Grebeck *June 19 – Sep 4, 1998*

Caltech, Pasadena, California, USA

Mario di Bernardo *Aug 3–9, 1998*

University of Bristol, Bristol, UK

Alfonso Lorenzo (P) *Aug 31 – Dec 20, 1998*

University of Santiago, Spain

Christos Yfoulis (P) *Sep 16 – Nov 26, 1998*

Control Systems Centre, UMIST, Manchester, UK

Angel Valera Fernández (P) *Oct 5 – Nov 30, 1998*

Universidad Politecnica de Valencia, Spain

Enrique Pico Marco (S) *From Oct 12, 1998*

DISA, U.P. Valencia, Valencia, Spain

11. Staff Activities

This is a short description of the staff (listed in alphabetic order) and their activities during the year. Publications and lectures are listed in separate sections.

Andersson, Leif

MSc, Research Engineer since 1970. Leif started at the department with a responsibility for the teaching laboratory. He designed some lab equipment, notably an analog computer. In 1976 he started in earnest with digital computers, and has been responsible for the department computing facilities since then. His professional activities, apart from computer system maintenance, have ranged from computer typesetting (T_EX and L^AT_EX) via Real Time Programming to using Java as a tool for writing educational software.

Andersson, Lennart

Lic Tech, graduate student since 1993. His current research interest is modeling of nonlinear and uncertain systems. During 1998 he was a teaching assistant in the basic courses Automatic Control and Automatic Process Control.

Åkesson, Mats

Lic Tech, MSc, graduate student since 1994. His main research interest is modeling and control of biotechnical processes. Currently, he is working together with Per Hagander on control of *E. coli* cultivations in a joint project with Pharmacia & Upjohn, Process R&D. He is also engaged in research collaborations with the Department of Biotechnology, Lund University and Active Biotech, Lund Research Center.

During 1998, Mats has been a teaching assistant in the courses Computer-Controlled Systems and Adaptive Control in the engineering curriculum, and he was involved in supervision of two MSc theses.

Staff Activities

In April and May, he spent four weeks at the Center for Agricultural Biotechnology, University of Maryland at College Park, USA, and visited the Systems Control Group, Department of Electrical Engineering, University of Toronto, Canada.

Årzén, Karl-Erik

Associate Professor, PhD (1987): Joined the department in 1981. His research interests are real-time systems, Petri nets and Grafcet, fuzzy control, and monitoring and diagnosis.

Project leader for the TFR project on Grafcet and recipe-based control, for the SSF/ARTES project on integrated control and scheduling, for the NUTEK project on programming languages for real-time control systems, and for the TFR/SSF industrial PhD project on industrial aspects of monitoring and diagnosis. During the year he has personally primarily been involved in the EU FAMIMO project on fuzzy control and in the SSF/ARTES project. He has been responsible for and taught the undergraduate courses on Real-Time Systems, the International Project Course on Automatic Control, and the graduate courses Discrete Event Systems and Project Course in Synthesis. He is partly or fully involved in the supervision of six PhD students.

Åström, Karl Johan

Professor since 1965, currently head of the department. He has interests in a broad range of control problems including stochastic and adaptive control, computer control, autonomous systems, and hybrid systems. This year he has been working on systems with switching, friction compensation, autonomous control, and modeling of physical systems such as boilers and HVDC systems. He also devotes time to develop control education and control laboratories.

During the year he has been chairman of the ESF program on Control of Complex Systems. He has participated in the IEEE CDC Conference and in several workshops. He has also been invited to give several plenary lectures.

Bernhardsson, Bo

PhD (1992), research associate at the department since 1993. Achieved the degree of Docent in 1998. Bo is interested in linear system theory, realtime control issues, motion control, hybrid control, and applied mathematics. He is project leader for the project on Analysis of Power Quality described in Section 5. During this year he (co-)supervised the PhD students Cervin, Grundelius, Gäfvert, Malmborg, Möllerstedt, and Nilsson on topics described in Section 5. He was also head of the LTH introduction programme 1998 for engineering physics students and a member of the committee "De Yngres Råd" instigated by the Rector of Lund Institute of Technology in 1998.

During the spring he organized the undergraduate course in Nonlinear Control and Servosystems and he was one of the organizers of the national conference Reglermöte '98. During the autumn he has helped organizing a PhD course in Control System Synthesis. He also supervised three master theses. In December he was elected to the honorary assignment as *Lucia* of the M-building at Lund Institute of Technology.

Blomdell, Anders

Research Engineer since 1988. Responsible for the department network and lab computers for teaching and research. Professional interest includes man machine interaction, real-time programming, hardware design, communication protocols, and computer languages for control engineering. During the last years, most effort has been spent at enhancing and porting the STORK Real Time Kernel to the various computer platforms used at the department (m680x0, PowerPC, Solaris and WindowsNT). A closely related project is the Modula-2 to C translator used in the real-time research and education at the department.

Braun, Rolf

Research Engineer at the department since 1969. Designs and builds equipment for education and research, and handles hardware maintenance of computers and equipment. He also plans and supervises maintenance and rebuilding of offices and labs. During the year he has been involved with the slosh control process, the rectilinear servo system from ECP, and much of the activities in the robotics laboratory.

Cervin, Anton

MSc, graduate student since May 1998. Anton's research interest is real-time systems, and he is involved in the ARTES project Integrated Scheduling and Control. During May–July he spent two months at The Software Engineering Institute at Carnegie Mellon University in Pittsburgh. He has been a teaching assistant in the Real-Time Systems course for engineering students.

Dagnegård, Eva

Webmaster. Joined the department as a secretary in 1975. She works mainly with graphics design and layout, both for paper publishing and for the web. She is also responsible for various activity reports, such as this one, and handles the contacts with printing offices for dissertations and other publications. During 1998 she handled much of the administration of Reglermöte '98 and the industrial course in connection to the meeting.

Delfin, Anna

MSc, started as a graduate student in September 1997 but left us again in April 1998. Anna was interested in modeling, and has been working in the project "Dynamic modeling of an ecocyclic pulp bleaching plant." She has been a teaching assistant in Automatic Process Control for chemical engineers.

Eborn, Jonas

Lic Tech, Graduate Student since 1995. Interested in computer aided control engineering, physical system modeling and numerical analysis. He is working in the NUTEK programme "Complex Technical Systems" and is also involved in the collaboration with Sydkraft AB. During 1998 he has been teaching assistant in System Identification and the basic course on Automatic Control. He has also supervised a master thesis on Thermohydraulic Modeling of Heleneholm Power Plant. He is also responsible for the departments seminar schedule.

Eker, Johan

Lic Tech in November 1997, graduate student since January 1995. His main interest are issues regarding implementation of embedded control

systems. For two weeks in January he visited Lui Sha at Carnegie Mellon University and worked on problems related to the “Integrated Control and Scheduling” project. During the year Johan was teaching assistant in the Automatic Control basic course and the Real-Time Systems course.

Gäfvert, Magnus

MSc, graduate student since July 1996. Magnus is interested in topics on distributed control and real-time systems. He is currently working with modeling, analysis, and control of systems with friction. He is also involved in the development of the computer based interactive tools for control education, ICTools. During the year he was a teaching assistant in Computer-Controlled Systems and Real-Time Systems.

Grundelius, Mattias

Lic Tech in November 1998, graduate student since January 1996. He is interested in Control in general and works with optimal control of packaging machines in a collaboration with Tetra Pak Research & Development AB. He has also been teaching assistant in the basic course in Automatic Control.

Hagander, Per

Associate professor, PhD (1973). Per has been with the department since 1968 and works with linear system theory and with applications in biotechnology and medicine. He is the director of studies at the department and also the department contactperson for industrial liasons. Per is responsible for the course in Automatic Process Control for the chemical engineers.

Since May 1996 he is leading a project with Pharmacia&Upjohn, Process R&D, on multivariable control of genetically engineered *E. coli*. Here Per works with Mats Åkesson.

Hägglund, Tore

Associate Professor, PhD (1984). Has been at the department since 1978 except for four years when he worked for Alfa Laval Automation AB. He is responsible for the economy at the department and for

Staff Activities

the two basic courses in Automatic Control in the engineering program. His main research interests include process control, PID control, adaptive control, supervision, and detection.

Main research activities during the year have been design of PID controllers and development of new supervisory functions for process control. He has also arranged the PhD course "Industrial case studies in control."

Hedlund, Sven

MSc, graduate student since September 1997. He is interested in control in general. He has been working in the FAMIMO project implementing a Matlab toolbox for the analysis of piecewise linear systems and is currently applying such methods on hybrid systems. Sven has been a teaching assistant in the courses Computer-Controlled Systems and Real-Time Systems in the engineering program.

During the summer he visited Tokyo Institute of Technology, Japan, where he worked with Professor T. Iwasaki.

Ingimundarson, Ari

Graduate student since November 1998. His research interests concern both design and application of control systems.

Johansson, Karl Henrik

Research associate, PhD (1997). Karl Henrik has been at the department since 1992. His research interests are in hybrid control systems, multivariable control, relay controller tuning, and various applications of control.

Karl Henrik lectured this year the graduate course Nonlinear Control Systems together with Bo Bernhardsson. He lectured a three-day course on HVDC control together with Karl Johan Åström and Tore Hägglund at ABB Power Systems AB in Ludvika. Karl Henrik supervised a master thesis project on control of a deaeration process at Tetra Pak, Lund, by Lars Johansson and Gabriele Nardini. He also supervised Michael Grebeck from CalTech, Pasadena, who made a project on the Quadruple Tank Process.

During the fall 1998, Karl Henrik was a visiting research fellow at the Department of Electrical Engineering and Computer Sciences, UC Berkeley. There he worked on Zeno hybrid automata. He has also worked in a project on HVDC control with ABB Power Systems AB in Ludvika.

Johansson, Mikael

MSc, PhD student since 1994. His research interests include modeling and analysis of nonlinear and hybrid control systems with a particular focus on systems with piecewise linear dynamics. During 1998, Mikael spent six months at the Laboratoire des Signaux et Systèmes (LSS) at Supelec, Paris. He was teaching assistant in the course 'Nonlinear Control and Servo Systems, and has also been involved in the development of interactive learning tools for control: ICTools.

Johansson, Rolf

Associate professor, MD, PhD (1983). Active at the department since 1979. His research interests are in system identification and in robotics and nonlinear systems. He is coordinating director for a NUTEK-sponsored research program "Lund Research Programme in Autonomous Robotics" with cooperation partners from Department of Production and Materials Engineering, Department of Industrial Electrical Engineering and Automation, and industrial partners. He has industrial cooperation with ABB Robotics, ABB Corporate Research, and Volvo Technical Development. Rolf is responsible for the two courses System Identification and Nonlinear Control and Servo Systems in the engineering program. Together with Dr. Måns Magnusson he leads research at the Vestibular Laboratory, Department of Otorhinolaryngology, Lund University Hospital.

During the year he has visited Departments of Mechanical Engineering and Electrical Engineering at Rice University in Houston, Laboratoire des Signaux et Systèmes at Supelec in France, and Heudiasyc at UT Compiègne in France.

Johnsson, Charlotta

Lic Tech 1997, graduate student since 1993. She is interested in supervisory control with focus on batch recipe management. She is currently working in the project “High-Level Grafset for Supervisory Sequential Control.” Her teaching assignments during 1998 have been in Automatic Process Control and the basic course Automatic Control.

Malmborg, Jörgen

PhD in May 1998, graduate student since 1991. His research interests are modeling and analysing of switched and hybrid control systems. He has been working within the project on hybrid control systems and has also been involved in the REGINA project “Heterogeneous Control of HVAC Systems.” In May he presented his PhD thesis “Analysis and Design of Hybrid Control Systems” and shortly after he left the department to work for Space Systems Sweden AB.

Mattsson, Sven Erik

Research associate, PhD (1985). Joined the department in 1976. From August 1, 1998, he is working with our research partner Dynasim to work with the future development of Modelica. Mattsson has been responsible for the research activities in computer aided control engineering (CACE) and is an active member of the Modelica design team since its conception in September 1996.

Möllerstedt, Erik

Lic Tech, graduate student since 1994. He is interested in analysis and control of nonlinear and switching systems with applications in power systems. He is working within the Elforsk project “Analysis of Electric Power Quality in Distributions and Loads.” He has been teaching assistant in the undergraduate courses Computer-Controlled Systems and Automatic Control.

Mårtensson, Britt-Marie

Secretary at the department since 1974, responsible for the maintenance of the department library, ordering books and journals. She handles the mail every day and office supplies for the department. Also works with scanning and drawing figures with the computer.

Nilsson, Johan

PhD 1998, graduate student since 1992. His research interests concerns both theory and applications. The major research area has been in the field of timing problems in real-time systems. In 1996 he took his Lic Tech exam, and in February 1998 he defended his PhD dissertation. Johan Nilsson left the department in August to work with Ericsson Mobile Communication.

Öhman, Martin

Lic Tech, graduate student since January 1996. His main research interest is model reduction, but he is also working with the PLC programming standard IEC 1131. In October 1998 he presented his licentiate thesis "Trajectory-Based Model Reduction of Nonlinear Systems." He has been teaching Automatic Control, basic course. In November 1998 he started to work for McKinsey & Company in Stockholm.

Panagopoulos, Hélène

Lic Tech, graduate student since September 1995. Her research interests concerns both theory and applications. The major research area is in the field of PID-controller design. During 1998 Hélène has been teaching assistant in the course Computer-Controlled Systems and Adaptive Control in the engineering program. In December she presented her Lic Tech dissertation "PID Controller Design."

Pedersen, Lars Malcolm

Lic Tech (1995), working at the department from 1992 to 1995 in connection with an industrial research project concerning thickness control for hot rolling mills. He is now back for a two year period from 1997 to 1999 working with temperature control of reheat furnaces. Lars has been an employee of The Danish Steel Works Ltd., Frederiksværk, Denmark, since 1991. For the time being he works half time on the Steel Work and half time at the department. Among his research interests are modeling, system identification, and nonlinear control, all applied to real systems in the steel industry.

Petersson, Mikael

Graduate student since 1997. Petersson is an industrial PhD-student employed by ABB Corporate Research. His research interests include monitoring and diagnostics of industrial processes, and applying and evaluating advanced theory in this area. The activities of the past year has been dominated by graduate courses and the knowledge build-up of the research area. During the year the main areas of research has been limited to reside within discrete manufacturing and process industry, namely the pulp and paper process.

Rantzer, Anders

Research associate, PhD (KTH 1991). Joined the department in 1993 after a postdoc position at IMA, University of Minnesota. Anders has broad interests in modeling, analysis, and design of control systems. In particular, he develops methods for treatment of uncertainty and nonlinearities using convex optimization.

Rantzer serves as associate editor of IEEE Transactions on Automatic Control, European Journal of Control and also Systems and Control Letters. In April this year, he organized a French-Swedish control meeting in Lund, with participants from six Swedish and four French engineering schools. He has also been participating in the 3rd Russian-Swedish Control Conference in Stockholm, the 4th IFAC Nonlinear Control Systems Design Symposium in Enschede, in a workshop on Robustness in Identification and Control in Siena and the 37th IEEE Conference on Decision and Control in Tampa.

Robertsson, Anders

PhD student, joined the department in 1993. Anders' current research is in nonlinear control and robotics. He is involved in the NUTEK project "Lund Research Programme in Autonomous Robotics." He has been a teaching assistant in the basic engineering course on Automatic Control.

During the period March 10 – April 5, 1997, Anders Robertsson visited professor H. Nijmeijer, the Systems and Control Group, TU Twente, The Netherlands. In October he visited Twente again for another week and participated in the dissertation procedure of Robert van der Geest.

Schildt, Eva

Secretary at the Department since 1970. Eva is mainly responsible for the financial transactions of the department, such as bookkeeping and reporting to our sponsors. She handles various personnel administration and takes care of the administration concerning the many visitors at the department. During 1998 she took part in the administration of Reglermöte'98 and was responsible for the secreteray program during the meeting.

Schönthal, Tomas

MSc, Research Engineer at the department since 1974. Primarily responsible for the development and maintenance of our line of software for control system analysis, design, and simulation. The most important programs have been Simnon, our first-generation simulation system, and Omola/OmSim, the modern successor. He has also taught Automatic Control in the engineering program. In August 1998 he left the department and works at present for Netlab, Lund University Library, with Internet-based information systems.

Sternby, Jan

Professor, adjuncted part-time (20%). He took his PhD at the department in 1977 and left in 1980 to work in industry. He is currently working in the Therapy Research group at Gambro AB in Lund. Jan Sternby spent 11 years as a part-time (25%) adjunct professor of automatic control at Luleå Technical University, where he supervised PhD students in the areas of anti-windup methods, control of systems with periodic disturbances, and crane control. His research interests also include adaptive control and all aspects of modeling in dialysis. He has developed a new course, Project in Control, which is part of the Master's program at the department.

Tummescheit, Hubertus

MSc in M.E. in 1996, Graduate Student since 1996, Graduate Student in Lund since July 1998. From February to July 1998 guest at the department, working in the NUTEK program "Complex Technical Systems." Interested in physical system modeling, especially for thermo-

dynamic systems, modeling languages, and numerical analysis. Since 1997 he is a member of the Modelica language design group and is also involved in the collaboration with Sydkraft AB.

Tuszynski, Agneta

Secretary at the department since 1981. She is responsible for registration of the student's course entries and exam results, and supervises the invoice payments from the department. She also works with word processing in L^AT_EX, helping colleagues with writing letters, articles, and reports.

Wallén, Anders

MSc, graduate student since 1991. His main research interests are control loop supervision and software design of control systems. He is working in the project "Autonomous Control." Anders was on leave of absence during the spring. During the autumn he was teaching assistant in the basic course on Automatic Control. He was also advisor in the master thesis project "Remote Control of Mobile Robots Using Petri Nets."

Wittenmark, Björn

Professor in Automatic Control since 1989. He joined the department in 1966 and took his PhD in 1973. His main research interests are adaptive control, sampled-data systems, and process control. He is working within the projects "Rolling Mill Control," "Timing Problems in Real-time Systems," and the new project "Center for Chemical Process Design and Control" sponsored by the Swedish Foundation for Strategic Research. He is also very active in developing learning tools for the courses in control. During the year he was one of the organizers of Reglermöte '98 arranged by the department.

Apart from his work at the department he is also Deputy Dean of Lund Institute of Technology.

External Assignments

Opponent and Member of Examination Committee

Karl-Erik Årzn: External examiner of the Licentiate thesis of Torbjörn Liljenvall, Department of Automatic Control, Chalmers, Gothenburg, Sweden. Substitute member of the examination committee for the PhD thesis of Roger Henriksson, Department of Computer Science, Lund Institute of Technology, Lund, Sweden. Substitute member of the examination committee for the PhD thesis of Per Runesson, Department of Communication Systems, Lund Institute of Technology, Lund, Sweden.

Bo Bernhardsson: Censor for the PhD-thesis by Marc Cromme at Denmark Tekniske Universitet, August 1998. Member of examination committee for the PhD thesis "Runge-Kutta Solution of Initial Value Problems: Methods, Algorithms and Implementation" by Hans Olsson, Numerical Analysis, Lund Institute of Technology, Lund, Sweden, December 1998.

Per Hagander: Member of the examination committee for Mats Jirstrand's PhD dissertation, Linköping University, Sweden, May 1998.

Tore Hägglund: External examiner for the PhD thesis "Fault-tolerant control systems—a development method and real-life case study" by Sören Abildsten Bögh, Aalborg University, Denmark.

Rolf Johansson: Member of the examination committee of Dr. M. Lourdes Penalver Herrero, Valencia, Spain, November 1998. External reviewer for professor appointment at The Norwegian University of Science and Technology (NTNU), Trondheim, Norway.

Anders Rantzer: Member of examination committee for PhD thesis by Anders Svensson, "Event Prediction and Bootstrap in Time Series," LTH, Lund, Sweden, November 1998.

Hubertus Tummescheit: External second PhD Supervisor for Gerhard Schmitz, Institut für Technische Thermodynamik, TU Hamburg-Harburg.

Board Member

Karl Johan Åström: Member of the Board of Mathematics, the Board of FIME (Physics, Mathematics, Electrical Engineering and Computer Science) at Lund University. Member of the Medal Committee of IVA. Member of the Committee for the Chester Carlsson Prize in Information Technology at IVA. Member of the Board of the SSF ARTES program. Member of the International Advisory Board for the SSF CAS project. Chairman for the Wallenberg Foundation WITAS program. Member of the Board of the NUTEK Regina program. Chairman of the COSY program of the European Science Foundation. Chairman of the Sydskraft Research Foundation. Chairman of the IFAC Committee for the Quazza and Nichols Medals.

Per Hagander: Vice-chairman of the Board of Engineering Physics program at Lund Institute of Technology. Member of the Computer Group of FED, Lund Institute of Technology. Member of the Board of University Library 2 at Lund University.

Tore Hägglund: Member of the Education Board of Computer Science and Technology, and deputy member of the Appointments Board II, both at Lund Institute of Technology.

Mikael Johansson: Deputy PhD student representative of the Board of Engineering Physics, Lund Institute of Technology, from July 1997. PhD student representative of the Board of Department of Automatic Control, Lund Institute of Technology, from July 1998.nn

Rolf Johansson: Member of the IEEE CDC/ACC Conference Editorial Board.

Sven Erik Mattsson: Member of the Modelica Design Group.

Björn Wittenmark: Deputy Dean and board member of Lund Institute of Technology. Board member of Lunds Universitets Utvecklings Aktiebolag (Lund University Development Limited). Board member of Chematur AB. Board member of Lunds Datacentral, LDC (Lund University Computing Center).

Book and Journal Editor

Karl-Erik Årzén: Advisory Editor for Engineering Applications of Artificial Intelligence.

Karl Johan Åström: Editor for International Journal on Control.

Tore Hägglund: Associate editor for Control Engineering Practice.

Rolf Johansson: Acted in an editorial book review for Cambridge University Press.

Anders Rantzer: Associate editor of IEEE Transactions on Automatic Control, European Journal of Control and also Systems and Control Letters.

Björn Wittenmark: Member of Editorial Boards for Optimal Control Applications & Methods, Journal of Forecasting, and International Journal of Adaptive Control and Signal Processing.

Advisory Committees and Working Groups

Karl Johan Åström: Member of the European Union Control Association (EUCA) Council.

Per Hagander: Member of IFAC Technical Committee on Biomedical Engineering and Control.

Mikael Johansson: Member of the IFAC Technical committee on Fuzzy and Neural Systems.

Björn Wittenmark: Member of the European Union Control Association (EUCA) Council.

Member of International Program Committee (IPC)

Karl Erik Årzén: Member of IPC for ADPM'98 (Automisation of Mixed Processes: Dynamic Hybrid Systems), Reims, France Member of IPC for INCOM'98 (Information Control Problems in Manufacturing), Nancy, France Member of IPC for IFAC Workshop on On-Line Fault Detection and Supervision in Chemical Process Industries, Lyon, France, 1998 Member of IPC for ICV'98 (IFAC Workshop on Intelligent Components

Staff Activities

for Vehicles), Sevilla, Spain Member of IPC for EuroMicro 99, York, UK
Member of IPC for ADPM 2000, Germany.

Tore Hägglund: Member of the International Program Committee for the
Third Portuguese Conference on Automatic Control, Coimbra, Portugal,
September 1998.

Rolf Johansson: Member of the international program committee of
Int. Symp. Robotics and Automation, Saltillo, Mexico, December 13-15,
1998.

Anders Rantzer: Member of International Program Committee for the
4th IFAC Nonlinear Control Systems Design Symposium in Enschede,
The Netherlands, July 1998.

Other Assignments

Björn Wittenmark: Lecturer in the *Distinguished Lectures Program of
the IEEE Control System Society* from 1993.

12. Publications and Conference Contributions

One proceedings, two book contributions, 22 journal papers, 37 conference contributions, and 11 conference abstracts have been published this year.

Books and Proceedings

Bernhardsson, Bo, and Björn Wittenmark, Eds.: *Preprints of Reglermöte '98*. Department of Automatic Control, Lund Institute of Technology, Lund, Sweden, 1998.

Book Contributions

Åström, Karl Johan: "A paradox in pole placement design." In Normand-Cyrot, Ed., *Perspectives in Control*. Springer, 1998.

Rantzer, Anders: "To estimate the L_2 -gain of two dynamic systems." In Blondel *et al.*, Eds., *Open Problems in Mathematical Systems and Control Theory*, chapter 36. Springer, 1999.

Journal Papers

Åström, Karl Johan, Hélène Panagopoulos, and Tore Hägglund: "Design of PI controllers based on non-convex optimization." *Automatica*, **35:5**, May 1998.

Bernhardsson, Bo, and Hélène Panagopoulos: "Comments on "Mixed L^∞ / H_∞ suboptimal controllers for SISO continuous time systems"." *IEEE Transactions on Automatic Control*, **43:9**, p. 1285, 1998.

Publications

- Hagander, Per, and Karl Johan Åström: "Advances in process control." *European Pharmaceutical Review*, **3:2**, pp. 29–33, 1998.
- Hansson, A., M. Holm, P. Blomström, R. Johansson, C. Lührs, and S. B. Olsson: "Right atrial free wall conduction velocity and degree of anisotropy in patients with stable sinus rhythm studied during open heart surgery." *European Heart Journal*, **19**, pp. 293–300, 1998.
- Holm, M., S. Pehrson, M. Ingemansson, L. Sörnmo, R. Johansson, L. Sandhall, M. Sunemark, B. Smideberg, C. Olsson, and S. B. Olsson: "Noninvasive assessment of the atrial cycle length during atrial fibrillation in man: Introducing, validating and illustrating a new ECG method." *Cardiovascular Research*, **38**, pp. 69–81, 1998.
- Johansson, Mikael, Karl Johan Åström, and Magnus Gäfvert: "Interactive tools for education in automatic control." *IEEE Control Systems*, **18:3**, pp. 33–40, June 1998.
- Johansson, Mikael, and Anders Rantzer: "Computation of piecewise quadratic Lyapunov functions for hybrid systems." *IEEE Transactions on Automatic Control*, **43:4**, pp. 555–559, April 1998. Special issue on Hybrid Systems.
- Johansson, R., M. Holm, S. B. Olsson, and J. Brandt: "System identification of atrial activation during chronic atrial fibrillation in man." *IEEE Transactions on Automatic Control*, **43:6**, pp. 790–799, June 1998.
- Malmberg, Jörgen, and Bo Bernhardsson: "Control and simulation of hybrid systems." *Nonlinear Analysis, Theory–Methods–Applications*, **30:1**, pp. 337–348, 1998.
- Mattsson, Sven Erik, Hilding Elmqvist, and Martin. Otter: "Physical system modeling with Modelica." *Control Engineering Practice*, **6**, pp. 501–510, 1998.
- Nilsson, Bernt, and Jonas Eborn: "Object-oriented modelling of thermal power plants." *Mathematical and Computer Modelling of Dynamical Systems*, **4:3**, pp. 207–218, September 1998.

- Nilsson, Johan, Bo Bernhardsson, and Björn Wittenmark: "Stochastic analysis and control of real-time systems with random time delays." *Automatica*, **34:1**, pp. 57–64, 1998.
- Nilsson, Klas, Anders Blomdell, and Olof Laurin: "Open embedded control." *Real-Time Systems*, **14:3**, pp. 325–343, 1998.
- Öhman, M., S. Johansson, and K.-E. Årzén: "Implementation aspects of the PLC standard IEC 1131-3." *Control Engineering Practice*, **6**, pp. 547–555, 1998.
- Olsson, Henrik, Karl Johan Åström, Carlos Canudas de Wit, Magnus Gäfvert, and Pablo Lischinsky: "Friction models and friction compensation." *European Journal of Control*, 1998.
- Olsson, S. B., A. Hansson, E. Hedin, M. Holm, M. Ingemansson, R. Johansson, C. Meurling, S. Pehrson, A. Roijer, and S. Yuan: "Atrial fibrillation—Some of today's challenges (in Chinese)." *Chin. J. Cardiac Arryth.*, **1:1**, pp. 58–62, 1997. Invited paper to Inaugural Issue.
- Panteley, Elena, Romeo Ortega, and Magnus Gäfvert: "An adaptive friction compensator for global tracking in robot manipulators." *Systems & Control Letters*, **33:5**, pp. 307–313, April 1998.
- Pedersen, Lars M., and Björn Wittenmark: "Multivariable controller design for hot rolling mill." *IEEE Trans. on Control Systems Technology*, **6**, pp. 304–312, 1998.
- Robertsson, Anders, and Rolf Johansson: "Comments on "Nonlinear output feedback control of dynamically positioned ships using vectorial observer backstepping"." *IEEE Trans. Control Systems Technology*, **6:3**, pp. 439–441, May 1998.
- Viswanathan, S., C. Johnsson, R. Srinivasan, V. Venkatasubramanian, and K-E. Årzén: "Automating operating procedure synthesis for batch processes: Part I. Knowledge representation and planning framework." *Computers and Chemical Engineering*, **22:11**, pp. 1673–1685, 1998.

Publications

- Viswanathan, S., C. Johnsson, R. Srinivasan, V. Venkatasubramanian, and K-E. Årzén: “Automating operating procedure synthesis for batch processes: Part II. Implementation and application.” *Computers and Chemical Engineering*, **22:11**, pp. 1686–1698, 1998.
- Wittenmark, Björn, Helena Haglund, and Mikael Johansson: “Dynamic pictures and interactive learning.” *Control Systems Magazine*, **18:3**, pp. 26–32, June 1998.

Conference Papers

- Åkesson, M., P. Hagander, and J. P. Axelsson: “Fermentation monitoring using feed rate transients.” In Skjöldebrand and Trystram, Eds., *Proceedings of the 4th International Symposium on Automatic Control of Food and Biological Processes*, Gothenburg, Sweden, September 1998.
- Åkesson, M., A. Tocaj, P. Hagander, and J. P. Axelsson: “Acetate formation and dissolved oxygen responses to feed transients in *Escherichia coli* fermentations: Modeling and experiments.” In Yoshida and Shioya, Eds., *Preprints of the 7th International Conference on Computer Applications in Biotechnology*, Osaka, Japan, June 1998.
- Aracil, Javier, Karl Johan Åström, and D. Pagano: “Global bifurcations in the Futura pendulum.” In *4th IFAC Nonlinear Control Systems Design Symposium (NOLCOS'98)*, pp. 35–39, 1998.
- Årzén, Karl-Erik: “A real-time systems course focused on control systems.” In *Proc. of IEEE Workshop on Real-Time Systems Education*. Poznan, Poland, 1998.
- Åström, Karl Johan: “Control of systems with friction.” In *The Fourth International Conference on Motion and Vibration Control, MoViC*, pp. 25–32, Zurich, Switzerland, August 1998. Invited plenary lecture.
- Åström, Karl Johan, Hilding Elmqvist, and Sven Erik Mattsson: “Evolution of continuous-time modeling and simulation.” In Zobel

- and Moeller, Eds., *Proceedings of the 12th European Simulation Multiconference, ESM'98*, pp. 9–18, Manchester, UK, June 1998. Society for Computer Simulation International.
- Barros, P. R., and B. Wittenmark: “Frequency domain sensitivity shaping in pole placement control.” In *12th Brazilian Automatic Control Conference*, Gerais, Brazil, September 1998.
- Braath, P., H. Rasmussen, and Tore Hägglund: “Control of the outlet air temperature in an air handling unit.” In *International Conference on Control'98*, Swansea, UK, 1998.
- Elmqvist, Hilding, Sven Erik Mattsson, and Martin Otter: “Modelica—An international effort to design an object-oriented modeling language.” In *Proceedings of the 1998 Summer Simulation Conference*, pp. 333–339, Reno, Nevada, July 1998. Society for Computer Simulation International.
- Elmqvist, Hilding, Sven Erik Mattsson, and Martin Otter: “Modelica—The new object-oriented modeling language.” In Zobel and Moeller, Eds., *Proceedings of the 12th European Simulation Multiconference, ESM'98*, pp. 127–131, Manchester, UK, June 1998. Society for Computer Simulation International.
- Johansson, K. H., B. James, G. F. Bryant, and K. J. Åström: “Multivariable controller tuning.” In *Proc. 17th American Control Conference*, Philadelphia, Pennsylvania, 1998.
- Johansson, K. H., and J. L. R. Nunes: “A multivariable laboratory process with an adjustable zero.” In *Proc. 17th American Control Conference*, Philadelphia, Pennsylvania, 1998. Best Paper in Session Prize.
- Johansson, Mikael: “A piecewise linear approach to local modeling and control.” In *1998 Open FAMIMO Meeting*, Sevilla, Spain, March 1998.
- Johansson, Mikael, Anders Rantzer, and Karl-Erik Årzén: “Piecewise quadratic stability for affine Sugeno systems.” In *Proc. 7th IEEE International Conference on Fuzzy Systems, Fuzz-IEEE*, Anchorage, Alaska, May 1998.

Publications

- Johansson, R., M. Magnusson, M. Karlberg, and P. A. Fransson: "Multi-stimulus multi-response posturography." In *Bárány Society Meeting*, Würzburg, Germany, September 1998.
- Johansson, R., and A. Robertsson: "Stability analysis of adaptive output feedback systems." In *IEEE Conf. Decision and Control (CDC'98)*, pp. 4008–4009, Tampa, Florida, December 1998.
- Johansson, R., and A. Robertsson: "Stability analysis of adaptive output feedback systems." In *1998 CINVESTAV Workshop on Nonlinear, Adaptive and Linear Systems*, Mexico City, December 1998. Abstract. Invited paper.
- Johansson, R., M. Verhaegen, C. T. Chou, and A. Robertsson: "Behavioral model identification." In *IEEE Conf. Decision and Control (CDC'98)*, Tampa, Florida, December 1998.
- Johansson, R., M. Verhaegen, C. T. Chou, and A. Robertsson: "Residual models and stochastic realization in state-space system identification." In *IEEE Conf. Decision and Control (CDC'98)*, pp. 3439–2444, Tampa, Florida, December 1998.
- Johnsson, Charlotta, and Karl-Erik Årzén: "Grafchart and batch recipe structures." In *WBF'98—World Batch Forum*. Baltimore, Massachusetts, April 1998.
- Johnsson, Charlotta, and Karl-Erik Årzén: "Grafchart and its relations to Grafcet and Petri nets." In *Proc. of Information Control Problems in Manufacturing (INCOM'98)*. Nancy, France, June 1998.
- Johnsson, Charlotta, and Karl-Erik Årzén: "Grafchart applications." In *GUS'98—Gensym User Society meeting*, May 1998.
- Johnsson, Charlotta, and Karl-Erik Årzén: "On batch recipe structures using high-level grafchart." In *Proc. of ADPM'98 (Automation of Mixed Processes: Dynamical Hybrid Systems)*. Reims, France, March 1998.
- Johnsson, Charlotta, and Karl-Erik Årzén: "Petri net analysis of batch recipes structured with Grafchart." In *FOCAPO'98—Foundations of Computer Aided Process Operations*, Snowbird, Utah, July 1998.

- Lantz, M., and A. Rantzer: "Robustness analysis of large differential-algebraic systems with parametric uncertainty." In *Proceedings of MTNS98*, Padova, Italy, 1998.
- Lindoff, B., J. Holst, and B. Wittenmark: "Analysis of suboptimal dual control." In *IFAC Workshop on Adaptive Control and Signal Processing*, pp. 20–27, Glasgow, UK, August 1998.
- Mattsson, Sven Erik, and Hilding Elmquist: "An overview of the modeling language Modelica." In Juslin, Ed., *Proceedings of the Eurosim'98 Simulation Congress*, pp. 182–186, Helsinki, Finland, April 1998. The Federation of European Simulation Societies.
- Nilsson, Johan, Bo Bernhardsson, and Björn Wittenmark: "Some topics in real-time control." In *Proc. 17th American Control Conference*, Philadelphia, Pennsylvania, June 1998.
- Pedersen, Lars M., and Björn Wittenmark: "On the reheat furnace control problem." In *Proc. 17th American Control Conference*, pp. 3811–3815, Philadelphia, Pennsylvania, 1998.
- Pedersen, Lars M., and Björn Wittenmark: "Thickness control for a plate mill." In *Preprints of Automation in Mining Mineral and Metal Processing*, pp. 331–336. IFAC, 1998.
- Rantzer, A., and A. Megretski: "Analysis of rate limiters using integral quadratic constraints." In *Proceedings of IFAC Nonlinear Control Systems Design Symposium*, pp. 696–700, Enschede, Netherlands, July 1998.
- Rantzer, A., and A. Megretski: "Harmonic analysis of nonlinear and uncertain systems." In *Proc. 17th American Control Conference*, Philadelphia, Pennsylvania, 1998.
- Robertsson, A., J. Eker, K. Nilsson, and R. Johansson: "Application-specific control for industrial robots." In *Proc. 3rd Portuguese Conference on Automatic control—Controlo98*, vol. 2, p. 877, Coimbra, Portugal, September 1998. Portuguese Association of Automatic Control (APCA). Poster presentation.

Publications

Robertsson, Anders, and Rolf Johansson: “Nonlinear observers and output feedback control with application to dynamically positioned ships.” In *4th IFAC Nonlinear Control Systems Design Symposium (NOLCOS'98)*, pp. 818–823, Enschede, Netherlands, July 1998.

Robertsson, Anders, and Rolf Johansson: “Observer backstepping and control design of linear systems.” In *IEEE Conf. Decision and Control (CDC'98)*, pp. 4592–4593, Tampa, Florida, December 1998.

Tummescheit, Hubertus, and Jonas Eborn: “Design of a thermo-hydraulic model library in Modelica.” In Zobel and Moeller, Eds., *Proc. of the 12th European Simulation Multiconference, ESM'98*, pp. 132–136, Manchester, UK, June 1998. SCS.

Wittenmark, B., B. Bastian, and J. Nilsson: “Analysis of time delays in synchronous and asynchronous control loops.” In *Proc. 37th Conference on Decision and Control*, Tampa, Florida, 1998.

Conference Abstracts

Åkesson, M., P. Hagander, and J. P. Axelsson: “A probing approach for detection of acetate formation.” In *Preprints of Reglermöte '98*, Lund Institute of Technology, Sweden, June 1998.

Bernhardsson, Bo, Karl Henrik Johansson, and Jörgen Malmberg: “Some properties of switched systems.” In *Preprints of Reglermöte '98*, Lund Institute of Technology, Sweden, 1998. Abstract.

Eborn, Jonas: “Experiences from using a model database for process modelling.” In *Preprints of Reglermöte '98*, pp. 68–72, Lund Institute of Technology, Sweden, June 1998.

Elmqvist, Hilding, Sven Erik Mattsson, and Martin Otter: “Modelica—An international effort to design an object-oriented modeling language.” In *Preprints of Reglermöte '98*, pp. 275–281, Lund, Sweden, July 1998. Department of Automatic Control, Lund Institute of Technology.

- Johansson, Karl Henrik, Anders Rantzer, and Karl Johan Åström: “Switched control systems.” In *Swedish–French Control Meeting*, Lund Institute of Technology, Sweden, 1998. Abstract.
- Johansson, R., and M. Magnusson: “New techniques in the analysis of posture.” In *Contributions of the Vestibular System to Oculomotor, Skeleto-motor and Perceptual Functions (in honour of Ottavio Pompeiano), 9–11 September, 1998*, Freiburg, Germany, September 1998. Abstract. Invited presentation.
- Johnsson, Charlotta, and Karl-Erik Årzén: “On batch recipe structures using High-Level Grafchart.” In *Preprints of Reglermöte '98*, Lund Institute of Technology, Lund, Sweden, June 1998.
- Möllerstedt, Erik, Sven Erik Mattsson, and Bo Bernhardsson: “A new approach to steady-state analysis of power distribution networks.” In *Preprints of Reglermöte '98*, pp. 269–274, Lund Institute of Technology, Sweden, June 1998.
- Pedersen, Lars M., and Björn Wittenmark: “Optimization of plate thickness controller.” In *Preprints of Reglermöte '98*, pp. 254–258, Lund Institute of Technology, Lund, Sweden, 1998.
- Sørlie, James, and Jonas Eborn: “Parameter optimization results for a family of thermo-physical drum boiler models.” In *Preprints of Reglermöte '98*, pp. 131–136, Lund Institute of Technology, Sweden, June 1998.
- Tummescheit, Hubertus, and Jonas Eborn: “Developing a thermo-hydraulic base library in Modelica.” In *Preprints of Reglermöte '98*, pp. 221–225, Lund Institute of Technology, Sweden, June 1998.

Technical Reports

- Nilsson, J., B. Wittenmark, M. Törngren, and M. Sanfridson: “Timing problems in real-time control systems.” In Törngren and Sanfridson, Eds., *Research problem formulations in the DICOSMOS project*, DAMEK, KTH, Stockholm, Sweden, 1998. Internal report ISRN KTH/MMK-98/20-SE.

13. Reports

Two PhD thesis and six Tech Lic theses have been published. The abstracts are presented in Chapter 8. Twenty master theses have been completed and 11 internal reports.

Dissertations

Åkesson, Mats: *A Probing Strategy for Substrate Feeding in Escherichia coli Cultivations*. Lic Tech thesis ISRN LUTFD2/TFRT-3220--SE, Department of Automatic Control, Lund Institute of Technology, Lund, Sweden, March 1998.

Eborn, Jonas: *Modelling and Simulation of Thermal Power Plants*. Lic Tech thesis ISRN LUTFD2/TFRT-3219--SE, Department of Automatic Control, Lund Institute of Technology, Lund, Sweden, February 1998.

Grundelius, Mattias: *Motion Control of Open Containers with Slosh Constraints*. Lic Tech thesis ISRN LUTFD2/TFRT-3222--SE, Department of Automatic Control, Lund Institute of Technology, Lund, Sweden, November 1998.

Malmberg, Jörgen: *Analysis and Design of Hybrid Control Systems*. PhD thesis ISRN LUTFD2/TFRT-1050--SE, Department of Automatic Control, Lund Institute of Technology, Lund, Sweden, May 1998.

Möllerstedt, Erik: *An Aggregated Approach to Harmonic Modelling of Loads in Power Distribution Networks*. Lic Tech thesis ISRN LUTFD2/TFRT-3221--SE, Department of Automatic Control, Lund Institute of Technology, Lund, Sweden, June 1998.

Nilsson, Johan: *Real-Time Control Systems with Delays*. PhD thesis ISRN LUTFD2/TFRT-1049--SE, Department of Automatic Control, Lund Institute of Technology, Lund, Sweden, January 1998.

Öhman, Martin: *Trajectory-Based Model Reduction of Nonlinear Systems*. Lic Tech thesis ISRN LUTFD2/TFRT-3223--SE, Department of Automatic Control, Lund Institute of Technology, Lund, Sweden, October 1998.

Panagopoulos, Hélène: *PID Controller Design*. Lic Tech thesis ISRN LUTFD2/TFRT-3224--SE, Department of Automatic Control, Lund Institute of Technology, Lund, Sweden, December 1998.

Master Theses

Bastian, Ben: "Analysis of time delays in synchronous control loops." Master thesis ISRN LUTFD2/TFRT-5597--SE, Department of Automatic Control, Lund Institute of Technology, Lund, Sweden, March 1998.

Cervin, Anton: "Dual control of an integrator using neuro-dynamic programming." Master thesis ISRN LUTFD2/TFRT-5598--SE, Department of Automatic Control, Lund Institute of Technology, Lund, Sweden, April 1998.

Elmér, Arvid: "Modeling and control of a continuous stirred tank fermenter with cell recycle." Master thesis ISRN LUTFD2/TFRT-5601--SE, Department of Automatic Control, Lund Institute of Technology, Lund, Sweden, June 1998.

Gamstedt, Jonas: "Reglering av siktesplattform med asynkronmotor," (Control of a director platform using an asynchronous motor). Master thesis ISRN LUTFD2/TFRT-5605--SE, Department of Automatic Control, Lund Institute of Technology, Lund, Sweden, November 1998.

Isaksson, Tommy: "Methods for tone-suppression in sigma-delta modulators." Master thesis ISRN LUTFD2/TFRT-5602--SE, Department of Automatic Control, Lund Institute of Technology, Lund, Sweden, September 1998.

Karlsson, Anders: "Remote control of a mobile robot using petri nets," (Fjärrstyrning av rörlig robot med hjälp av Petrinät). Master thesis ISRN LUTFD2/TFRT-5604--SE, Department of Automatic

- Control, Lund Institute of Technology, Lund, Sweden, December 1998.
- Karlsson, Johan: "Tools for configuration and analysis of control loops." Master thesis ISRN LUTFD2/TFRT--5607--SE, Department of Automatic Control, Lund Institute of Technology, Lund, Sweden, December 1998.
- Lagerblad, Niklas: "Digital control of a gantry crane with unconventional sampling." Master thesis ISRN LUTFD2/TFRT--5590--SE, Department of Automatic Control, Lund Institute of Technology, Lund, Sweden, January 1998.
- Liljengren, Dan: "Tuning of gain parameters in commercial servo controllers." Master thesis ISRN LUTFD2/TFRT--5596--SE, Department of Automatic Control, Lund Institute of Technology, Lund, Sweden, March 1998.
- Månsson, Jonas: "Control of chromatography column in production scale." Master thesis ISRN LUTFD2/TFRT--5599--SE, Department of Automatic Control, Lund Institute of Technology, Lund, Sweden, May 1998.
- Nardini, Gabriele, and Lars Johansson: "Modeling of a tetra pak deaeration process." Master thesis ISRN LUTFD2/TFRT--5600--SE, Department of Automatic Control, Lund Institute of Technology, Lund, Sweden, June 1998.
- Nilsson, Christine, and Martin Råberg: "Termohydraulisk modellering av Heleneholmsverket," (Thermo-hydraulic modelling of Heleneholmsverket thermal power plant). Master thesis ISRN LUTFD2/TFRT--5606--SE, Department of Automatic Control, Lund Institute of Technology, Lund, Sweden, December 1998.
- Nunes, José Luís: "Modeling and control of the quadruple-tank process." Master thesis ISRN LUTFD2/TFRT--5588--SE, Department of Automatic Control, Lund Institute of Technology, Lund, Sweden, March 1998.
- Olofsson, Holger, and Petra Posselius: "Adaptive eccentricity compensation—An experimental study." Master thesis ISRN

Reports

LUTFD2/TFRT--5603--SE, Department of Automatic Control, Lund Institute of Technology, Lund, Sweden, October 1998.

Persson, Mikael: "Stop & go controller for adaptive cruise control." Master thesis ISRN LUTFD2/TFRT--5609--SE, Department of Automatic Control, Lund Institute of Technology, Lund, Sweden, December 1998.

Recica, Valon: "Automatic tuning of multivariable pid controllers." Master thesis ISRN LUTFD2/TFRT--5592--SE, Department of Automatic Control, Lund Institute of Technology, Lund, Sweden, February 1998.

Rentsch, Martin: "Controlling a ball and plate process using computer vision." Master thesis ISRN LUTFD2/TFRT--5595--SE, Department of Automatic Control, Lund Institute of Technology, Lund, Sweden, March 1998.

Svensson, Joakim: "Effects of friction on the Furuta pendulum." Master thesis ISRN LUTFD2/TFRT--5593--SE, Department of Automatic Control, Lund Institute of Technology, Lund, Sweden, January 1998.

Tornhagen, Casper, and Fredrik Persson: "Object oriented simulation of a paper machine." Master thesis ISRN LUTFD2/TFRT--5594--SE, Department of Automatic Control, Lund Institute of Technology, Lund, Sweden, February 1998.

Übelacker, Daniel: "Object-oriented modeling of an HVAC system." Master thesis ISRN LUTFD2/TFRT--5608--SE, Department of Automatic Control, Lund Institute of Technology, Lund, Sweden, December 1998.

Other Reports

Åkesson, Mats, and Per Hagander: "Control of dissolved oxygen in stirred bioreactors." Report ISRN LUTFD2/TFRT--7571--SE, Department of Automatic Control, Lund Institute of Technology, Lund, Sweden, February 1998.

- Andersson, Lennart, Magnus Gäfvert, Sven Hedlund, and Charlotta Johnsson: "Praktikfall i reglerteknik – råspritbränneriet i Nöbbelöv," (Industrial case studies in control – the crude alcohol distillery in Nöbbelöv). Report ISRN LUTFD2/TFRT--7573--SE, Department of Automatic Control, Lund Institute of Technology, Lund, Sweden, 1998.
- Andersson, Lennart, and Anders Rantzer: "Frequency dependent error bounds for uncertain linear models." Report ISRN LUTFD2/TFRT--7575--SE, Department of Automatic Control, Lund Institute of Technology, Lund, Sweden, August 1998.
- Åström, K. J., and R. D. Bell: "Drum-boiler dynamics." Report ISRN LUTFD2/TFRT--7577--SE, Department of Automatic Control, Lund Institute of Technology, Lund, Sweden, September 1998.
- Dagnegård, Eva, and Per Hagander: "Automatic control 1997. Activity report." Report ISRN LUTFD2/TFRT--4025--SE, Department of Automatic Control, Lund Institute of Technology, Lund, Sweden, March 1998.
- Eborn, Jonas, Per Karlsson, and Hélène Panagopoulos: "Praktikfall i reglerteknik: ICOPAL AB," (Industrial case studies in control). Report ISRN LUTFD2/TFRT--7578--SE, Department of Automatic Control, Lund Institute of Technology, Lund, Sweden, September 1998.
- Eker, Johan, Mattias Grundelius, and Mikael Petersson: "En dag på bruket – studie av temperaturreglering i ångflöde," (One day at the mill—Study of temperature control in steamflow). Report ISRN LUTFD2/TFRT--7580--SE, Department of Automatic Control, Lund Institute of Technology, Lund, Sweden, November 1998.
- Grebeck, Michael: "A comparison of controllers for the quadruple tank system." Report ISRN LUTFD2/TFRT--7576--SE, Department of Automatic Control, Lund Institute of Technology, Lund, Sweden, August 1998.
- Nilsson, Johan: "Two toolboxes for systems with random delays." Report ISRN LUTFD2/TFRT--7572--SE, Department of Automatic Control, Lund Institute of Technology, Lund, Sweden, April 1998.

Reports

Panagopoulos, H el ene: "Research abstracts 1998—PhD projects in automatic control." Report ISRN LUTFD2/TFRT--7579--SE, Department of Automatic Control, Lund Institute of Technology, Lund, Sweden, August 1998.

Pedersen, Lars Malcolm: "Slab temperature control for reheating furnaces." Report ISRN LUTFD2/TFRT--7581--SE, Department of Automatic Control, Lund Institute of Technology, Lund, Sweden, November 1998.

Reports Available

Only a limited number of copies of our reports are available for sale from the Department. Any of the listed publications may, however, be borrowed through your library service or from the following libraries in Sweden:

- Link opings Universitetsbibliotek, Svensktrycket, SE-581 83 Link oping
- UB 2, Svenska Tryckavdelningen, Box 1010, SE-221 03 Lund
- Stockholms Universitetsbibliotek, Svenska Tryckavdelningen, SE-106 91 Stockholm
- Kungliga Biblioteket, Box 5039, SE-102 41 Stockholm
- Ume  Universitetsbibliotek, Box 718, SE-901 10 Ume 
- Uppsala Universitetsbibliotek, Box 510, SE-751 20 Uppsala

The reports in the 1000- and 3000-series may be ordered from the Department. See addresses on page 4. Please be certain to specify both the report number and report title.

There is a copying and handling charge of between 300 and 500 SEK for each document. Invoice will be sent together with the ordered report(s).

14. Lectures by the Staff Outside the Department

Seminars and lectures given by the staff outside the department. The persons are listed alphabetically.

Åkesson, Mats

A Probing Strategy for Substrate Feeding in Escherichia coli Cultivations, Center for Agricultural Biotechnology, University of Maryland, College Park, Maryland, USA, April 17, 1998.

A Probing Strategy for Substrate Feeding in Escherichia coli Cultivations, Systems Control Group, Department of Electrical Engineering, University of Toronto, Canada, May 7, 1998.

A Probing Strategy for Substrate Feeding in Escherichia coli Cultivations: The Return of the Pulse Program, Pharmacia & Upjohn, Process R&D, Stockholm, Sweden, October 2, 1998.

A Probing Strategy for Substrate Feeding in Escherichia coli Cultivations, NUTEK Program workshop, Arlanda, Sweden, October 22, 1998.

A Probing Feeding Strategy for Recombinant E. coli Cultures, Active Biotech, Lund Research Center AB, Lund, Sweden, December 17, 1998.

Andersson, Lennart

Comparison and Simplification of Uncertain Models, MIT, Boston, USA, November 17, 1998.

Årzén, Karl-Erik

Grafchart and Recipe-Based Control, Linköping University, Sweden, April 2, 1998.

Piecewise Quadratic Stability for Affine Sugeno systems, IEEE Conference on Fuzzy Systems, Anchorage, Alaska, May 5, 1998.

Lectures by the Staff

Fuzzy Control, Industrial Course at Lund University, Sweden, June 10, 1998.

Real-Time and Control: Part 1–2, Tutorial at ARTES Summer School, Lidingö, Sweden, Aug 17, 1998.

Real-Time and Control: Part 3, Tutorial at ARTES Summer School, Lidingö, Sweden, Aug 21, 1998.

A Nonlinear Perspective on Intelligent Control, Workshop on Intelligent Control, Darmstadt, Germany, Oct 29, 1998.

A Real-Time Systems Course Focused on Control Systems, IEEE Workshop on Real-Time Systems Education, Poznan, Poland, Nov 21, 1998.

Åström, Karl Johan

Hybrid Control of Inverted Pendulum, Workshop on Learning, Control and Hybrid Systems Centre for Artificial Intelligence & Robotics, Bangalore, India, Jan 5, 1998.

Automatic Control, Short industrial course on automatic control, ABB Power Systems, Ludvika Sweden, February 24–27, 1998. Given together with T. Hägglund and K. H. Johansson.

Intelligent Control, University of New Brunswick, Fredericton, NB, Canada, March 23, 1998.

Automatic Control - The Hidden Technology, Dineen Memorial Lecture, University of New Brunswick, Fredericton, NB, Canada, March 23, 1998.

Automatic Control - The Hidden Technology, Dineen Memorial Lecture, University of New Brunswick, St John, NB, Canada, March 24, 1998.

Control of Systems with Friction, Workshop on Control, University of California, Santa Barbara, California, USA, April 2, 1998.

Singularities in a System with Switching, Swedish-French Control Meeting TRIDENT, Lund, Sweden, April 23, 1998.

Singularities in a System with Switching, Third Russian-Swedish Control Conference, Royal Institute of Technology, Stockholm, Sweden, May 10, 1998.

PID Control, Industrial Course at Lund University, Lund, Sweden, June 10, 1998.

Reglerteknikens utveckling och dess framtid (Automatic Control Its Development and Its Future, Reglermöte (The Swedish Control Conference), Lund, Sweden, June 10, 1998.

Adaptive Control, University of Glasgow, UK, June 16, 1998.

Evolution of Continuous-Time Modeling and Simulation, European Simulation Multiconference, ESM'98, Manchester, UK, June 18, 1998.

A Paradox in Pole Placement Design, Perspectives in Control, CNRS Paris, France, June 29, 1998.

Control of Systems with Friction, Invited Plenary Lecture, MOVIC'98, The 4th International Conference on Motion and Vibration Control, Zürich, Switzerland, August 27, 1998.

Reflections on Control Engineering Education, Invited Plenary Lecture, XIX Jornadas de Automática, University of Madrid, Spain, September 16, 1998.

Real and Virtual Laboratory Processes, NSF Workshop on New Directions in Control Engineering Education, University of Illinois, Urbana, Illinois, USA, October 2, 1998.

Automatic Control – A Perspective, Perspectives in Control. Harvard University, Cambridge, Massachusetts, USA, October 23, 1998.

Friction Models and Friction Compensation, Workshop on Intelligent Control Systems, Darmstadt, Germany, October 29, 1998.

Practical Methods for on-line Tuning of Industrial Controllers, Industrial course at PATO, Utrecht, The Netherlands, November 17, 1998.

Trends in Automatic Control, ICIMS-NOE Meeting, Brussels, Belgium, November 23, 1998

Friction, Short course given with C. Canudas de Wit and M. Sorine at the IEEE Conference on Decision and Control, Tampa, Florida, USA, December 14, 1998.

Bernhardsson, Bo

Some Realtime Control Problems, Invited presentation at the Third Russian-Swedish Control Conference. Stockholm, Sweden, May 11, 1998.

Harmonic Norton Equivalents, Invited presentation in the SEEN-network at DTU, Lyngby, Denmark, Aug 25, 1998.

More on Harmonic Norton Equivalents, Invited presentation in the SEEN-network at Malmö Technical College, Malmö, Sweden, Sep 23, 1998.

Control of Realtime Systems With Random Time Dealsys, Invited presentation at S3, KTH, Stockholm, Sweden, Sep 23, 1998.

Event-Based Sampling—A Small Case Study, Invited presentation at S3, KTH, Stockholm, Sweden, Sep 23, 1998.

Eborn, Jonas

Object-Oriented Modelling in Lund, Invited seminar. IMM/DTU, Denmark, Jan 27, 1998.

Design of a Thermohydraulic Library in Modelica, Seminar. LTH, Sweden, Aug 26, 1998.

Design of a Thermohydraulic Library in Modelica, Seminar. COSY meeting, ETH, Switzerland, Aug 28, 1998.

Modelling and Control of Energy Processes, Seminar. Sydkraft Forskningsstiftelsedag, Malmö, Sweden, Sep 10, 1998.

Modelling of Thermohydraulic Processes, Seminar. CPDC-möte, Göteborg, Sweden, Sep 23, 1998.

Grundelius, Mattias

Control of Slosh in a Packaging Machine, Invited lecture, Darmstadt University of Technology, Darmstadt, Germany, Oct 29, 1998.

Motion Control—Control of Slosh in a Packaging Machine, NUTEK Regina Conference, NUTEK, Stockholm, Sweden, Nov 9, 1998.

Hagander, Per

Bioprocess Control, Lecture and laboratory in course, Dept of Physics and Measurement Technology, Linköping, Sweden, March 27, 1998.

Biosensorer ur en reglerteknikers synvinkel, Invited lecture, workshop on “Biologi och teknik i samverkan,” Nutek, Stockholm, Sweden, Oct 16, 1998

Hägglund, Tore

Friction Detection and Compensation, Linköping University, Sweden, March 12, 1998.

Automatic Supervision in Control of Chemical Processes, “Kemiforum”, Gothenburg, Sweden, April 24, 1998.

Process Control and Control Strategies in Modern DCS Systems, Workshop arranged by Alfa Laval AS, Oslo, Norway, April 28, 1998.

Johansson, Karl Henrik

Switched Control Systems, Invited seminar at Department of Electrical Engineering, Linköping University, March 5, 1998.

Switched Control Systems, Invited seminar at S3—Automatic Control, Royal Institute of Technology, Stockholm, Sweden, March 26, 1998.

Switched Control Systems, Invited seminar at Department of Signals and Systems, Chalmers University of Technology, Gothenburg, Sweden, April 3, 1998.

Switched Control Systems, Swedish–French Control Meeting, Lund Institute of Technology, April 25, 1998.

A Multivariable Laboratory Process with an Adjustable Zero, 17th American Control Conference, Philadelphia, Pennsylvania, USA, June 25, 1998.

Multivariable Controller Tuning, 17th American Control Conference, Philadelphia, Pennsylvania, USA, June 26, 1998.

Relay Feedback Systems, Department of Electrical Engineering and Computer Sciences, University of California at Berkeley, California, USA, October 12, 1998.

Lectures by the Staff

Zeno Hybrid Automata, Department of Electrical Engineering and Computer Sciences, University of California at Berkeley, California, USA, October 19, 1998.

Fast Switchings and Sliding Modes in Relay Feedback Systems, Invited seminar at Department of Engineering Mathematics, University of Bristol, Bristol, UK, December 7, 1998.

Johansson, Mikael

Analysis of Piecewise Linear Systems using Piecewise Quadratic Lyapunov Functions, Supelec, Paris, France, April 1997.

Johansson, Rolf

System Modeling and Identification, Invited Short Course (20h), Rice University, Houston, Texas, USA, May 4–8, 1998.

Extension of the Yakubovich-Kalman-Popov Lemma for Stability Analysis of Dynamic Output Feedback Systems, Laboratoire des Signaux et Systèmes, Supelec, Gif-sur-Yvette, France, June 23, 1998.

Extension of the Yakubovich-Kalman-Popov Lemma for Stability Analysis of Dynamic Output Feedback Systems, Heudiasyc, UT Compiègne, Compiègne, France, July 10, 1998.

New Techniques in the Analysis of Posture, Invited lecture, Contributions of the Vestibular System to Oculo-motor, Skeleto-motor and Perceptual Functions (in honor of Ottavio Pompeiano), Freiburg University, Freiburg, Germany, September 11, 1998.

Multi-Stimulus Multi-Response Posturography, Bárány Society Meeting, Würzburg, Germany, September 15, 1998.

System Identification of Robot Manipulator Dynamics, Universidad Politecnica de Valencia, Valencia, Spain, November 3, 1998.

Stability Analysis of Adaptive Output Feedback Systems, Invited lecture, CINVESTAV V Workshop on Nonlinear, Adaptive and Linear Systems, Mexico City, Mexico, December 11–12, 1998.

Residual Models and Stochastic Realization in State-Space System Identification, IEEE Conf. Decision and Control (CDC'98), Tampa, Florida, USA, December 16–18, 1998.

Behavioral Model Identification, IEEE Conf. Decision and Control (CDC'98), Tampa, Florida, USA, December 16–18, 1998.

Stability Analysis of Adaptive Output Feedback Systems, IEEE Conf. Decision and Control (CDC'98), Tampa, Florida, USA, December 16–18, 1998.

Johnsson, Charlotta

On Batch Recipe Structures Using High-Level Grafchart, Conference on Automation of Mixed Processes: Dynamical Hybrid Systems (ADPM'98), Reims, France, March 19–20, 1998.

Grafchart and Batch Recipe Structures, The conference World Batch Forum (WBF'98), Baltimore, Maryland, USA, April 26–29, 1998.

Grafchart Applications, Gensym User Society meeting GUS'98, Newport, Rhode Island, USA, May 13–15, 1998.

On Batch Recipe Structures Using High-Level Grafchart, The Swedish control meeting Reglermöte'98, Lund, Sweden, June 11–12, 1998.

Grafchart and Its Relations to Grafcet and Petri Nets, Conference on Information Control Problems in Manufacturing (INCOM'98), Nancy, France, June 24–26, 1998.

Formal Analysis of Batch Recipes Structured with Grafchart, Conference on Foundations of Computer Aided Process Operations, FO-CAPO'98, Snowbird, Colorado, USA, July 5–10, 1998.

Doktorandgenomströmning – Erfarenheter från Reglerteknik, Invited lecture, Personalutvecklingens dag LU, Lund University, Sweden, October 21, 1998.

High-Level Grafcet for Supervisory Sequential Control, Nutek Regina Evaluation, Lund, Sweden, November 11, 1998.

Möllerstedt, Erik

A New Approach to Steady-State Analysis of Power Distribution Networks, Invited lecture, Reglermöte '98, Lund, Sweden, June 12, 1998.

Panagopoulos, Hélène

H_∞ Design of PID Controllers, Plenary lecture. Nordic Process Control Workshop 8, Skeviks Gärd, Stockholm, Sweden, August 25, 1998.

Pedersen, Lars Malcolm

Thickness Control for a Hot Rolling Mill, Institutet for Skibs- og Havteknik, DTU, Denmark, June 15, 1998.

Rantzer, Anders

Control of Piecewise Linear Systems, Invited lecture. Daimler Benz, Berlin, Germany, Jan 23, 1998.

Harmonic Oscillations in Nonlinear and Uncertain Systems, Invited lecture. Third Russian-Swedish Control Conference, Stockholm, Sweden, May 11, 1998.

Analysis of Rate Limiters using Integral Quadratic Constraints, 4th IFAC Nonlinear Control Systems Design Symposium. Enschede, The Netherlands, July 3, 1998.

Robustness Analysis of Large Differential Algebraic Systems, Invited lecture. Workshop on Robustness in Identification and Control, Siena, Italy, Aug 1, 1998.

Robust and Nonlinear Control, Invited lecture. Swedish Defence Research Establishment (FOA). Stockholm, Sweden, Sep 16, 1998.

To Estimate the L₂-gain of Two Dynamic Systems, Invited lecture. 37th IEEE Conference on Decision and Control. Tampa, Florida, USA, Dec 16, 1998.

Tummescheit, Hubertus

Introduction to Object-Oriented Modelling with Modelica, Invited Seminar. Institut für Technische Thermodynamik, TU Hamburg-Harburg, Germany, July 17, 1998.

Medium Properties for Dynamic Simulation, Seminar. COSY meeting, ETH, Switzerland, Aug 28, 1998.

Issues in Modeling of Thermo-Hydraulic Systems, Seminar. Workshop on Intelligent Control Systems, TH Darmstadt, Germany, Oct 28, 1998.

Wittenmark, Björn

Some Process Control Paradigms, Plenary lecture, ACoFoP IV, Gothenburg, Sweden, September 22, 1998.

Timing Problems in Real-Time Control Systems, Industry seminar for the research project DICOSMOS, KTH, Stockholm, Sweden, October 9, 1998.

Adaptive Control, short course during 8th Latinamerican Congress on Automatic Control, Viña del Mar, Chile, November 9–10, 1998.

A Survey of Adaptive Control Applications, Plenary lecture, 8th Latinamerican Congress on Automatic Control, Viña del Mar, Chile, November 12, 1998.

15. Seminars at the Department

Seminars presented in order of date. The seminars were given at the department during 1998, both by the staff and by invited lecturers. Dissertations and master theses presentations are also included.

AC = Department of Automatic Control, Lund Institute of Technology

LTH = Lund Institute of Technology

Niklas Lagerblad (LTH): *Digital Control of a Gantry Crane with Unconventional Sampling*. Jan 16, 1998. MSc-thesis presentation.

Helena Andreas (LTH): *Underwater Locomotion using Swimming Cylinders*. Jan 16, 1998. MSc-thesis presentation.

Joakim Svensson (LTH): *Effects of Friction on the Furuta Pendulum*. Jan 23, 1998. MSc-thesis presentation.

Jonas Eborn (AC): *Modelling and Simulation of Thermal Power Plants*. Feb 2, 1998. Lic Tech dissertation seminar.

Valon Recica (LTH): *Automatic Tuning of Multivariable PID Controllers*. Feb 10, 1998. MSc-thesis presentation.

Johan Nilsson (AC): *Real-Time Control Systems with Delays*. Feb 11, 1998. Doctoral dissertation defence.

Henrik Olsson (Daimler-Benz, Germany): *Aspects of Control of Electrical Drive Systems for Locomotives*. Feb 12, 1998.

Casper Tornhagen, Fredrik Persson (LTH): *Object-Oriented Simulation of a Paper Machine*. Feb 17, 1998. MSc-thesis presentation.

Njal Pettit (Danfoss, Denmark): *Analysis and Control of Discontinuous Nonlinear Systems using a Piecewise Linear Approach*. Feb 19, 1998.

Seminars at the Department

Morten Christensen, Bo Eliasson (DTU, Denmark; LTH Malmö, Sweden): *Array-based Configuration in Power Systems*. Feb 27, 1998.

Mats Åkesson (AC): *A Probing Strategy for Substrate Feeding in Escherichia coli Cultivations*. March 23, 1998. Lic Tech dissertation seminar.

Jan Sternby (AC): *Modelling of Dialysis, I*. March 24, 1998.

Ben Bastian (AC): *Analysis of Time Delays in Asynchronous Control Loops*. March 26, 1998.

Svante Littmark, Lars Langemyr, Per-Olof Persson (Comsol) *FEMLAB - Multiphysics in MATLAB*. March 26, 1998.

Bo Bernhardsson (AC): *The Real Perturbation Values and Their Applications*. March 31, 1998.

Jan Sternby (AC): *Modelling of Dialysis, II*. April 2, 1998.

Mathias Bollen (Chalmers): *Recent Developments in Power Quality*. April 22, 1998.

Erik Möllerstedt (AC): *An Aggregated Approach to Harmonic Modelling of Loads in Power Distribution Networks*. April 22, 1998.

Keith Glover, Glenn Vinnicombe (Cambridge University, UK): *Robust Control using H_∞ Loop Shaping*. Graduate course, May 5, 1998.

Anton Cervin (LTH): *Dual Control of an Integrator Using Neuro-Dynamic Programming*. May 5, 1998. MSc-thesis presentation.

Dan Liljengren (LTH): *Tuning of Gain Parameters in Commercial Servo Controllers*. May 5, 1998. MSc-thesis presentation.

Keith Glover, Glenn Vinnicombe (Cambridge University, UK): *Robust Control using H_∞ Loop Shaping*. Graduate course, May 6, 1998.

Glenn Vinnicombe (Cambridge University, UK): *Robust Control using H_∞ Loop Shaping*. Graduate course, May 7, 1998.

Glenn Vinnicombe (Cambridge University, UK): *Robust Control using H_∞ Loop Shaping*. Graduate course, May 8, 1998.

Zheng Li (School of Electr, Comp. and Telecom. Eng, Australia): *Minimum Variance Control of Time-Varying Linear Systems*. May 19, 1998.

Mattias Grundelius (AC): *Control for Sloss-Free Motion*. May 25, 1998.

Jonas Klevhag (Mechanical Dynamics Inc.): *Mechanical System Simulation using ADAMS*. May 25, 1998.

Jonas Månsson (LTH): *Control of Chromatography Column in Production Scale*. May 26, 1998. MSc-thesis presentation.

Jörgen Malmborg (AC): *Analysis and Design of Hybrid Control Systems*. May 28, 1998. Doctoral dissertation defence.

Shankar Sastry (University of California, Berkeley): *Air Traffic Management Systems: A Case Study in Hybrid Control*. May 29, 1998.

Michael Branicky (Case Western Reserve Univ., Ohio): *Capturing Hybrid Behaviour*. June 2, 1998.

Lars Johansson, Gabriele Nardini (LTH): *Modeling of a Tetra Pak Deaeration Process*. June 9, 1998. MSc-thesis presentation.

Erjen Lefeber (University of Twente, Netherlands): *On the Adaptive Tracking Control of Nonholonomic Systems*. June 17, 1998.

Alex Progomsky (Linköping Institute of Technology): *Passivity Based Design of Synchronizing Systems*. June 23, 1998.

Arvid Elmér (LTH): *Modeling and Control of a Continuous Stirred Tank Fermenter with Cell Recycle*. June 26, 1998. MSc-thesis presentation.

Mario di Bernardo (University of Bristol): *Nonsmooth Bifurcations and Chaos in PWM Controlled DC-DC Converters*. August 4, 1998.

Anuradha Annaswamy (MIT): *An Adaptive Control Theory for Systems with Nonlinear Parametric*. August 18, 1998.

Anuradha Annaswamy (MIT): *Active Control of Combustion Processes: An Emerging Technology*. August 19, 1998.

Seminars at the Department

Leonid Naimark (Technion, Israel): *Robust Stability and Robust Controller Design for Uncertain Delay Systems*. Aug 19, 1998.

Jakob Fredsted (Danfoss, Denmark): *Introduction to Danfoss, Interests in Modelling and Experiences with Sinda/Fluint*. Aug 26, 1998.

Njal Pettit (Danfoss, Denmark): *Developing a General Dynamic Simulation Model for Evaporators and Condensers Using a Moving Boundary Formulation*. Aug 26, 1998.

Arne Jakobsen (Danfoss, Denmark): *Problems with Combining Component Models with System Models*. Aug 26, 1998.

Michael Grebeck (CalTech): *A Comparison of Controllers for the Quadruple Tank System*. Aug 27, 1998.

Tommy Isaksson (LTH): *Methods for Tone-Suppression in Sigma-Delta Modulators*. Sep 7, 1998. MSc-thesis presentation.

Anton Shiriaev (NTNU Trondheim, Norway): *Swinging Up of Spherical Pendulum*. Sep 17, 1998.

Alec Stothert (University of Witwatersrand, Johannesburg): *Distributed Computer Control in the Presence of Timing Jitter*. Sep 21, 1998.

Christos Yfoulis (UMIST, UK): *Robust Stabilization of Piecewise Linear Systems using Piecewise Linear Lyapunov-like Functions*. Sep 22, 1998.

Alec Stothert (University of Witwatersrand, Johannesburg): *Multi-Agent Techniques for Power Grid Modelling*. Sep 22, 1998.

Laurent Praly (Ecole des Mines de Paris, France): *Nonlinear Design, I*. Graduate course, Sep 28, 1998.

Laurent Praly (Ecole des Mines de Paris, France): *Nonlinear Design, II*. Graduate course, Sep 29, 1998.

Laurent Praly (Ecole des Mines de Paris, France): *Nonlinear Design, III*. Graduate course, Sep 30, 1998.

Martin Öhman (AC): *Trajectory Based Model Reduction of Nonlinear Systems*. Oct 9, 1998. Lic Tech dissertation seminar.

Holger Olofsson, Petra Posselius (LTH): *Adaptive Eccentricity Compensation*. Oct 15, 1998. MSc-thesis presentation.

Andrey Ghulchak (AC): *A Nonstandard H_∞ Control Problem*. Oct 20, 1998.

Maria-Christina Laiou (Imperial College, UK): *Discontinuous Stabilization of Nonlinear Systems*. Oct 22, 1998.

Ian Petersen (Australian Defence Force Academy): *Minimax LQG control*. Oct 30, 1998.

Kishan Baheti (NSF, USA): *Intelligent Engineering Systems: A New Paradigm for Systems and Control Engineering*. Nov 3, 1998.

John Baras . Nov 4, 1998.

Anders Karlsson (LTH): *Remote Control of a Mobile Robot Using Petri Nets*. Nov 19, 1998. MSc-thesis presentation.

Jonas Gamstedt (LTH): *Control of a Director Platform Using an Asynchronous Motor*. Nov 19, 1998. MSc-thesis presentation.

Mattias Grundelius (AC): *Motion Control of Open Containers with Slosh Constraints*. Nov 20, 1998. Lic Tech dissertation seminar.

Karl Henrik Johansson (University of California, Berkeley): *Regularization of Zeno Hybrid Automata*. Nov 26, 1998.

Thomas Gillblad (Object Automation): *OAenterprise*. Nov 26, 1998.

Alfonso Lorenzo Rodriguez (AC): *Intraoperative Control of Heart Rate and Mean Arterial Blood Pressure by Alfentanil Infusion Using a Fuzzy Logic Controller*. Nov 30, 1998.

Sven Göran Bergh (Industrial Communication): *Overview of Wonderware's Products such as In-Touch, In-Control, In-Batch, In-Alarm, etc..* Dec 2, 1998. Part of engineering course.

Mikael Persson (LTH): *Stop & Go Controller for Adaptive Cruise Control*. Dec 7, 1998. MSc-thesis presentation.

Christine Nilsson, Martin Råberg (LTH): *Termo-Hydraulic Modelling of Heleneholmsverket Thermal Power Plant*. Dec 7, 1998. MSc-thesis presentation.

Seminars at the Department

Hélène Panagopoulos (AC): *PID Controller Design*. Dec 12, 1998. Lic Tech dissertation seminar.

Lars Malcolm Pedersen (AC): *Slab Temperature Control for Reheating Furnaces, Literature Review*. Dec 11, 1998.

Johan Karlsson (LTH): *Tools for Configuration and Analysis of Control Loops*. Dec 14, 1998. MSc-thesis presentation.

Daniel Übelacker (LTH): *Object-Oriented Modelling of an HVAC System*. Dec 21, 1998. MSc-thesis presentation.

Ulf Holmberg (Halmstad Högskola): *SysQuake—Interactive Computer Tool for Signal Analysis and Control*. Dec 21, 1998.