



# LUND UNIVERSITY

## The Role of the Cortico-Basal Ganglia-System in Voluntary Movements

Tamté, Martin

2016

[Link to publication](#)

*Citation for published version (APA):*

Tamté, M. (2016). *The Role of the Cortico-Basal Ganglia-System in Voluntary Movements*. [Doctoral Thesis (compilation), Integrative Neurophysiology]. Integrative Neurophysiology, Lund University.

*Total number of authors:*

1

### General rights

Unless other specific re-use rights are stated the following general rights apply:

Copyright and moral rights for the publications made accessible in the public portal are retained by the authors and/or other copyright owners and it is a condition of accessing publications that users recognise and abide by the legal requirements associated with these rights.

- Users may download and print one copy of any publication from the public portal for the purpose of private study or research.
- You may not further distribute the material or use it for any profit-making activity or commercial gain
- You may freely distribute the URL identifying the publication in the public portal

Read more about Creative commons licenses: <https://creativecommons.org/licenses/>

### Take down policy

If you believe that this document breaches copyright please contact us providing details, and we will remove access to the work immediately and investigate your claim.

LUND UNIVERSITY

PO Box 117  
221 00 Lund  
+46 46-222 00 00



# The Role of the Cortico-Basal Ganglia-System in Voluntary Movements

Making sense of a non-sense

**Martin Tamtè**

Integrative Neurophysiology, Neuronano Research Center  
Faculty of Medicine | Lund University 2016



**LUND**  
UNIVERSITY

Martin Tamtè

The Role of the Cortico-Basal Ganglia-System in Voluntary Movements

37

Lund university, Faculty of medicine  
Doctoral dissertation series 2016:37  
ISBN 978-91-7619-263-4  
ISSN 1652-8220



**LUND UNIVERSITY**  
Faculty of Medicine

ACADEMIC DISSERTATION

**The role of the cortico-basal ganglia-system in voluntary movement**

**- Making sense of a non-sense**

**Martin Tamtè**



**LUND**  
**UNIVERSITY**

With the approval of the Faculty of Medicine at Lund University,  
this thesis will be defended on the 31<sup>st</sup> of March, 2016, at 09.00  
in the Pufendorf Institute, Lund, Sweden

*Faculty opponent*

Professor Judith Walters  
National Institutes of Health  
Bethesda, MD, USA

<b>Organization</b> LUND UNIVERSITY Integrative Neurophysiology & Neurotechnology Neuronano Research Center Department of Experimental Medical Science Medicon Village, A2 221 84, Lund, Sweden	<b>Document name</b> DOCTORAL DISSERTATION	
	<b>Date of issue</b> 31 <sup>st</sup> of March, 2016	
	Sponsoring organization	
<b>Author:</b> Martin Tamtè		
<b>Title and subtitle</b> The role of the cortico-basal ganglia-system in voluntary movement - Making sense of a non-sense		
<b>Abstract</b> <p>Bodies with multiple limbs and joints have endless possibilities to move around in their surrounding space. How the nervous system controls this amount of degrees of freedom in motor execution is a question under vigorous debate. In an ambition to explore related aspects of motor control we conducted parallel electrophysiological recordings of motor circuits in the cortex and basal ganglia in the consciously behaving rodent during the execution of various motor behaviors.</p> <p>To be able to further explore the relevance of neuronal activation patterns for different behaviours within these motor structures, we developed two methods - one focusing on increasing the amount of information acquired from the neuronal recordings and the other on improved motion tracking. The first method enabled a flexible electrode construction for targeting of multiple regions of the brain simultaneously. In the motion tracking system an anatomically defined model of the rodent paw was developed. With high resolution recordings a detailed reconstruction of a complex movement permitted differentiation of multiple kinematic parameters that could be related to the electrophysiological recordings. In experiments employing a reach and grasp paradigm, we were able to correlate the neuronal code to a previously suggested subdivision of the compound movement into functional sub-components, in effect validating the method.</p> <p>In further studies we utilized the 6-OHDA rodent model of Parkinson's disease, where motor control is impaired. Here we found that levodopa induced-dyskinesia was tightly associated with a strong oscillatory phenomenon in the motor cortex, and that stopping the oscillation locally was sufficient for alleviation of motor symptoms. By expanding the neuronal recordings using the developed electrode we showed that different states of the disease could be reliably discerned. When comparing these disease states with a control state, we could thus assess the effect of drugs in their ability to normalize disease-relevant signals. The validity of this procedure was verified by correlation between the behavioral and neuronal measures. These experiments demonstrate that neuronal measures of internal states can be utilized for evaluation of new treatment strategies and have a high potential in aiding drug development for diseases without clear behavioral phenotypes.</p>		
<b>Key words:</b> Neurophysiology, Electrophysiology, Pharmacology, Motor Systems, Voluntary movements, Philosophy, In-vivo, Corticostriatal, Basal Ganglia, Parkinson's Disease, Dyskinesia, Levodopa, Multiple Electrode Arrays		
<b>Classification system and/or index terms (if any):</b>		
Supplementary bibliographical information:		Language: Eng (Swe, Shq)
ISSN: 1652-8220		ISBN: 978-91-7619-263-4
Recipient's notes	Number of pages: 162	Price: -
	Security classification: Official	

Signature

Date: 29<sup>th</sup> February 2016

# **The role of the cortico-basal ganglia-system in voluntary movement**

- Making sense of a non-sense



**LUND**  
UNIVERSITY

**Martin Tamtè**

*Integrative Neurophysiology & Neurotechnology  
Neuronano Research Center  
Department of Experimental Medical Science  
Faculty of Medicine  
Lund University*

Cover art:

“The ever expanding mind”

By Kushtrim Regjepaj, M.A.

Albanian translation

By Samir Luani, ICT

© Martin Tamtè 2016  
and the respective publishers

Lund University, Faculty of Medicine Doctoral dissertation series: 37

ISBN 978-91-7619-263-4

ISSN 1652-8220

Printed in Sweden by Holmbergs

Malmö 2016

iv

**To my beloved,  
future and past**

*“What could I say to you that would be of value, except that perhaps you seek too much,  
that as a result of your seeking you cannot find”*

- Hermann Hesse



# Table of content

Original papers .....	9
Summaries in Swedish, English & Albanian .....	11
Abbreviations .....	17
<b>Preface</b> .....	19
<b>Introduction</b> .....	25
<i>The periphery</i> .....	28
<i>The spinal cord</i> .....	28
<i>Cortex</i> .....	29
<i>The Basal ganglia</i> .....	30
<i>Striatum</i> .....	31
<i>Pathways within the basal ganglia</i> .....	33
<i>Thalamus</i> .....	35
<i>Motor system disorders</i> .....	37
<i>Oscillations</i> .....	38
<i>Treatments</i> .....	39
<i>Animal models</i> .....	41
<b>Aims</b> .....	43
<b>Material and Methods</b> .....	47
<i>Experimental techniques</i> .....	49
<i>Analytical measures</i> .....	52
<b>Results &amp; Motivations</b> .....	55
<b>Study I</b> .....	57
“On the analysis of movement in neurophysiological research” .....	57
<b>Study II</b> .....	62
“On the Corticostriatal network during PD and levodopa-induced dyskinesia.” .....	62
<b>Study III</b> .....	67
“On the further development of large-scale electrophysiological recordings” .....	67
<b>Study IV</b> .....	69
“On the cortico-basal ganglia loop in levodopa-induced dyskinesia treatments” .....	69

<b>Discussion &amp; Concluding Remarks</b> .....	75
<i>Behavioral models</i> .....	77
<i>Oscillations &amp; dyskinesia</i> .....	79
<i>Future applications</i> .....	82
<i>Merging data</i> .....	83
<i>General concluding remarks</i> .....	84
Acknowledgements .....	85
References.....	91
<b>Appendix</b> .....	111



# Original papers

- I. \*Tobias Palmér, \*Martin Tamtè, Pär Halje, Olof Enqvist and Per Petersson  
“A system for automated tracking of motor components in neurophysiological research“  
*Journal of Neuroscience Methods, Volume 205, Issue 2, 15 April 2012, Pages 334–344.*
  
- II. \*Pär Halje, \*Martin Tamtè, Ulrike Richter, Mohsin Mohammed, M. Angela Cenci and Per Petersson  
“Levodopa-induced dyskinesia is strongly associated with resonant cortical oscillations”  
*Journal of Neuroscience, Volume 32, Issue 47, 21 November 2012, Pages 16541-16551.*
  
- III. \*Nedjeljka Ivica, \*Martin Tamtè, Maruf Ahmed, Ulrike Richter and Per Petersson  
“Design of a high-density multi-channel electrode for multi-structure parallel recordings in rodents”  
*36th Annual International IEEE EMBS Conference of the IEEE Engineering in Medicine and Biology Society, Date: 26-30 August 2014, 2014, Pages 393-396.*
  
- IV. Martin Tamtè, Ivani Brys, Nedjeljka Ivica, Ulrike Richter, Pär Halje and Per Petersson  
“Systems level neurophysiological state characteristics for drug evaluation in an animal model of levodopa-induced dyskinesia”  
*Journal of Neurophysiology (in press)*

\* These authors contributed equally and are listed in alphabetical order



# Populärvetenskaplig sammanfattning

Nervsystemet är sannolikt en av de mest vidunderliga strukturer som skapats i detta universum - denna avhandling hade till exempel varken kunnat skrivas eller läsas utan det. Som av en slump handlar den också om just nervsystemet och läsande och skrivande är två exempel på olika funktioner som möjliggjorts på grund av det. Även om dessa utgör funktioner som är ovanliga utanför vår egen art, människan, så skapas alla sorters intryck och uttryck utifrån samma fundament: genom en tvåsamhet mellan sensorik och motorik.

Inom neurovetenskapen finns en uppsjö av frågor och tekniker som tillåter studier av nervsystemets olika funktioner och i denna avhandling ligger fokus på hur motorik programmeras av diverse hjärnstrukturer under olika tillstånd. Genom att implantera elektroder som mäter aktivitet hos nervceller i specifika hjärnområden samtidigt som olika beteenden uttrycks har vi kunnat mäta vilka förändringar i nervcellers signalering som kan kopplas till den motoriska aktiviteten. Vanligtvis görs detta genom en manuell klassning av diverse beteendeegenskaper som sedan associeras till den uppmätta nervcellsaktiviteten, men då detaljerade korrelationer kräver hög upplösning i både tid och rum så blir detta ofta en onödigt krävande process. För att få den detaljnivå som krävs för att kunna utröna vilka parametrar i ett beteende som är kontrollerade i de registrerade hjärnstrukturerna så utvecklade vi ett datoriserat system som automatiskt klassar beteendet med avseende på parametrar såsom vinklar över leder, rörelseriktning och hastighet. Detta gjordes på ett beteende där en råtta tar en godisbit med hjälp av en sträckrörelse med tassens, som är jämförbar med vissa målinriktade handrörelser i människor. Genom att samtidigt mäta nervcellsaktivitet från två hjärnområden kända för sin inblandning i motorik kunde vi med denna teknik visa att den fullständiga rörelsen kodades neuronalt på ett sätt som tidigare hade föreslagits utav detaljerade beteendestudier - i form av mindre, funktionella komponenter som sätts samman i skapandet av den komplexa rörelsen. Förutom att ge en indikation på ett vis som hjärnan under normala omständigheter skulle kunna programmera rörelser, så indikerade det att metoden för beteendeklassificering är en fördelaktig teknik att utnyttja i mer detaljerade framtida studier.

I nästkommande studie ville vi också studera samma strukturers inflytande under ett sjukdomstillstånd, för att se om de förändringar av beteendet som sjukdomen skapar kunde förklaras av förändringar i den uppmätta nervcellsaktiviteten. I människor och djurmodeller av Parkinson's sjukdom som behandlas med en effektiv symptomlindrande medicin kallad levodopa så uppkommer vanligtvis biverkningar i form av ofrivilliga och syfteslösa rörelser kallade dyskinesier. Under detta biverkningstillstånd fann vi en kraftig förändring i signaleringen i en känd men i situationen förbisedd hjärnstruktur samtidigt som symptomen uppvisades. Vi hade härmed hittat en potentiellt ny mekanism på en ny plats i hjärnan som

teoretiskt skulle kunna bli ett mål för att motverka biverkningarna. Genom att behandla bara denna struktur, motorhjärnbarken, med en experimentell medicin som motverkar den primära behandlingen så kunde vi ytterligare stärka sambandet mellan symptombilden och den onormala signalen, då stävandet av den också hämmade de ofrivilliga rörelserna. Detta var glädjande eftersom i det fall biverkningar från en i övrigt fördelaktig behandling kan hindras så blir ursprungssjukdomen ett mycket mindre problem för patienten.

Då vi vid detta lag sett att de hjärnstrukturer vi mätt ifrån varit inblandade på olika vis i de olika tillstånd vi studerat så ville vi utveckla elektroderna för nervcellsmätningarna så att de skulle kunna anpassas för att mäta från många fler hjärnstrukturer samtidigt. Vi antog att om alla de områden vi mätte ifrån bidrog med unik fakta om vad som sker, så kommer den totala informationen från dessa experiment kunna öppna upp för nya frågeställningar och användningsområden. I samma uppställning med levodopa-behandlade parkinson-djur som innan kunde vi genom simultana mätningar från åtta olika hjärnområden per hjärnhalva hitta skillnader mellan normala och sjukliga tillstånd som förr inte kunnat beskrivas med samma detaljrikedom. Denna samtida beskrivning av sjukt och friskt tillät oss att testa mediciner för att se hur en behandling av ett sjukt tillstånd påverkade hjärnsignalerna i stora delar av hjärnan, vilket kunde jämföras med signalerna från det friska tillståndet. På så sätt kunde vi utöver den tydliga påverkan på beteendet också se hur bra en medicin verkade genom att direkt titta på hjärnsignalerna. Eftersom en medicins ospecifika påverkan på beteenden kan vara väldigt svår att klassificera med standardiserade skalor anpassade för specifika sjukdomssymptom, så blir detta ett efterlängtat sätt att istället utnyttja kroppsegna signaler för utvärdering av en medicins effekt. För psykiatriska sjukdomar till exempel, där förändringar i beteende är mindre uppenbara än i motoriska sjukdomar, så skulle detta kunna ge en inblick i effekten av ett läkemedel som kan användas för läkemedelsutvecklingssyften för dessa i dagsläget svårbehandlade tillstånd.

I sin helhet har innehållet i denna avhandling bidragit till att komplettera existerande kunskap om nervsystemets roll i motorik under normala och sjuka förhållande, till den grad att nya frågor inom ämnet kan börja ställas och i sinom tid besvaras. Med ett sådant förfarande kommer förhoppningsvis den potentiella nyttan av resultaten motivera att både grund- och applicerad forskning bör vara en naturlig del av alla samhällen.

# Summary

The development of a refined nervous system has had great influence over the survival power of the individual. The main role of the central nervous system is to allow suitable outputs based on inputs constrained by the peripheral nervous system. One rudimentary example of this is the direct reflex circuit, where the input of one neuronal cell is tightly linked to the output of another neuron in both space and time, producing a response reliably predictable already from the information of the electrochemical source signal. In contrast, voluntary movements imply a free will and require more complexity than the causation of a monosynaptic circuit, which is provided by additional pathways in the spinal cord and brain. At the outermost boundary of the brain resides the cerebral cortex, which is especially prominent in humans and the most recently developed encephalic structure. Bordering within this lies a developmentally older collection of interconnected nuclei called the Basal Ganglia that receives, and feeds back to, many of the signals passing from the cortex through the spinal cord to the muscles that produce movements. The activity of neurons in motor cortex, together with parts of basal ganglia, form a network that is known to have strong influence over bodily movements and the aim of this thesis has been to study the function of this combined network in relation to motor behavior in health and disease. To enable this, we have developed an adaptable method that allows for simultaneous measurement from multiple parts of the rodent brain. Applying this in awake and behaving subjects, we have preliminarily shown that for a learned complex “reach & grab” behavior, consisting of smaller movements stacked together to become functional, signals in the cortico-striatal system precede and dynamically correspond to these motoric sub-components. This is in line with what has been shown before in the spinal cord and encourages further study as to what features of movements the coding elements from different levels affects.

To further understand the neural principles underlying normal function, it can often be informative to examine a system under malfunction. To this end we chose to study the side effects of involuntary movements due to the main treatment for Parkinson’s disease (PD) in an established animal model of this common disease. Here we found a striking oscillatory phenomenon in the signal from the cortical region of the brain, corresponding tightly to the expression of these continuous abnormal movements. Interestingly, the aberrant signal could be reliably interrupted by antagonizing dopamine receptors locally in motor cortex, at which point symptoms were relieved. In effect this added a new pathological phenomena in a contextually overlooked region of the brain, with a proposed experimental treatment, opening up for new questions to be posed on the subject.

Emerging from the clearly distributed signals from these studies was the notion that signals of healthy and non-healthy states of behavior can be differentiated with enough



electrophysiological information. Employing a method to reduce the high dimensionality of our multivariate data while retaining as much of the information as possible, we could reliably represent distinct brain states from normal and pathological conditions. Following this, the potential for an alternative way to calculate and illustrate effects for treatments targeting neurological conditions arose, and neurophysiological states induced by centrally acting drugs were added to the representations. In this way we were able to track geometrical relations between different drug states and the pathological and healthy states in a common space, to obtain an internal measure of treatment efficacy based on their relative distance from each other. By demonstrating the viability of using signals from large brain networks for drug evaluations in Parkinson's disease and dyskinesia, we are now underway to verify the method for additional diseases, many of which lack clear behavioral phenotypes that can be correlated to the pathology.

Considering the increasingly high attrition rates in drug development due to efficacy related issues, approaches increasing accuracy in readouts of true therapeutic effects are likely to increase the current translatability of common pre-clinical findings, not least in the staggering field of drug development for CNS diseases. Taken together, the work included in this thesis has aimed to provide a balanced amount of answered and unanswered questions in basic and applied neuroscience and will serve as a foundation for future work in this intriguing field.

# Përmbledhje

Zhvillimi i sistemit nervor të stërholluar ka patur një ndikim të madh në aftësinë e mbijetesës së individit. Roli kryesor i sistemit nervor qendror është mundësimi i sinjaleve të duhura dalëse në bazë të sinjaleve hyrëse të kapura nga sistemi nervor periferik. Një shembull rudimentar i kësaj është qarku i refleksit direkt, ku sinjali hyrës i njërit neuron është ngushtë i lidhur në hapësirë dhe kohë me sinjalin dalës të një neuroni tjetër, duke shkaktuar një reagim besueshmërisht të parashikueshëm që nga informacioni i sinjalit burimor elektrokimik. Në kontrast me këtë, lëvizjet e vullnetshme kërkojnë vullnet të lirë dhe kompleksitet më të madh se shkakësia e një qarku njësinaptik, gjë që mundësohet nga vijat më të shumta të palcës kurrizore dhe trurit. Te kufiri më i skajshëm i trurit gjendet korja e trurit, që është veçanërisht e përparuar te njeriu dhe po ashtu struktura trunore më e re në pikëpamje të zhvillimit. Brenda kufijve të saj gjendet një koleksion zhvillimisht më i moçëm bërthamash të ndërlidhura, i quajtur ganglionet bazale, i cili pranon dhe u përgjigjet sinjaleve të shumta që kalojnë nga korja, nëpër palcën kurrizore e deri te muskujt që përftojnë lëvizje. Aktiviteti i neuroneve në koren motorike, së bashku me disa pjesë të ganglioneve bazale, formon një rrjet për të cilin dihet se ka ndikim të fortë në lëvizjet e trupit. Synimi i këtij disertacioni ka qenë që të studiohet funksioni i këtij rrjeti të përbërë, në raport me sjelljet motorike në gjendje të shëndoshë dhe të sëmurë. Për ta mundësuar këtë, kemi zhvilluar një metodë të adaptueshme që lejon matje të njëkohshme nga disa pjesë të trurit të brejtësit. Duke e zbatuar këtë te objektet eksperimentale në gjendje të zgjuar dhe vepruese, ne fillimisht kemi dëftuar që për sjelljet e mësuara komplekse të llojit “arrij dhe kap”, të përbëra nga lëvizje të vogla të mbledhura bashkë për të qenë funksionale, sinjalet në sistemin kortikostriacal u pararendin këtyre nënkomponenteve motorike dhe përputhen dinamikisht me këto. Kjo gjë është në vijë me ato që janë dëftuar më parë në lidhje me palcën kurrizore dhe nxit studime të mëtutjeshme për të parë se cilat tipare të lëvizjeve ndikohen nga elementet kyçe të niveleve të ndryshme.

Për kuptim më të mirë të parimeve neurale që qëndrojnë prapa funksionit normal, ekzaminimi i një sistemi gjatë keqfunksionimit mundet shpeshherë të jetë informativ. Për ta arritur këtë në vendosëm t'i studionim efektet anësore të lëvizjeve të pavullnetshme si pasojë e trajtimit kryesor për sëmundjen e Parkinsonit (PD) në një model të etabluar shtazor për këtë sëmundje të zakonshme. Aty zbuluam një dukuri të dallueshme lëkundëse në sinjalin nga zona e kores së trurit, që përputhet ngushtë me shprehjen e lëvizjeve të vazhdueshme anormale. Është interesante që sinjali i rravguar mundet të pengohet në mënyrë të besueshme nga receptorët antagonistues të dopaminës në vend në koren motorike, me ç'rast simptomat zbuteshin. Në fakt kjo gjë shtoi edhe një dukuri të re patologjike në një zonë kontekstualisht të papërfillur të trurit, me një trajtim të sugjeruar eksperimental, duke lënë hapësirë për pyetje të reja në këtë temë.

Një nocion që doli nga sinjalet e qarta të këtyre studimeve ishte ai që sinjalet e gjendjeve të shëndetshme dhe jo të shëndetshme të sjelljes mund të diferencohen me informacion të mjaftueshëm elektrofiziologjik. Me zbatimin e një metode për reduktim të dimensionalitetit të lartë të të dhënave tona shumëvariable, duke ruajtur sa më shumë informata, ne në mënyrë të besueshme arritëm t'i dallonim në reprezentime gjendjet e veçanta të trurit nga gjendjet normale dhe patologjike. Pas kësaj u krijua mundësia për një mënyrë alternative të kalkulimit dhe ilustrimit të efekteve të trajtimit të gjendjeve neurologjike, dhe reprezentimeve u shtuam edhe gjendje neurofiziologjike të shkaktuara nga barërat me veprim qendror. Në këtë mënyrë mundeshim t'i gjurmonim relacionet gjeometrike ndërmjet gjendjeve të ndryshme të shkaktuara nga barërat dhe gjendjeve patologjike e të shëndetshme në një hapësirë të përbashkët, për të bërë matje të brendshme të efikasitetit të trajtimit në bazë të largësive të tyre relative nga njëra-tjetra. Duke e demonstruar mundësinë e përdorimit të sinjaleve nga rrjetet e mëdha trunore për vlerësimet e barërave në sëmundjen e Parkinsonit dhe në diskinezi, ne tani jemi duke i u afruar verifikimit të kësaj metode edhe për sëmundje të tjera, nga të cilat shumë nuk kanë fenotipe të qarta sjelljesh që mundën të bashkëlidhen me patologjinë. Duke e marrë parasysh shkallën e lartë të hollimit në zhvillimin e barërave për shkak të çështjeve që kanë të bëjnë me efikasitetin, ato mënyra të qasjes që e rrisin saktësinë e leximeve të efekteve të vërteta terapeutike janë ato që më së shumti mundën ta rrisin përkthyeshmërinë aktuale të zbulimeve paraklinike, sidomos në lëmin marramendës të zhvillimit të barërave për sëmundjet e SNQ. Puna e përfshirë në këtë disertacion synon në tërësi të parashtrojë një sasi të balancuar pyetjesh me përgjegje dhe pa përgjegje në neuroshkencë themelore dhe të zbatuar, dhe do të shërbejë si bazë për punime të ardhshme në këtë lëm mahnitës.

# Abbreviations

## *General:*

AIM – Abnormal involuntary movement  
DoF – Degrees of freedom  
LID – Levodopa-induced dyskinesia  
MEA – Multiple electrode array  
PD – Parkinson's disease

## *Structures:*

M1 (MI) – Primary motor cortex  
BG – Basal Ganglia  
DLS/DMS – Dorsolateral & dorsomedial striatum  
GPi/GPe – Globulus pallidus, internal & external parts  
SNc/SNr – Substantia nigra, compact & reticular parts  
STN – Subthalamic nucleus  
Th – Thalamus

## *Biochemicals:*

Serotonin (5-HT) – 5-hydroxytryptamine  
ACh – Acetylcholine  
GABA – Gamma-aminobutyric-acid  
Glu – Glutamatergic acid (Glutamate)  
Levodopa (L-Dopa, LDA) – L-3,4-dihydroxyphenylalanine

## *Cells:*

ChAt – Striatal cholinergic interneuron  
IN – Interneuron  
MSN – Medium sized spiny neuron  
PC – Pyramidal cell  
TAN – Tonically active neuron

## *Receptors:*

AMPA –  $\alpha$ -amino-3-hydroxy-5-methyl-4-isoxazolepropionic acid receptor  
DR<sub>1</sub>/DR<sub>2</sub> – Dopamine receptor families 1 & 2  
NMDAR – N-methyl-D-aspartate receptor

## *Signals:*

EEG – Electroencephalogram  
LFP – Local field potential  
AP (Spike) – Action potential



# Preface



## “The first move”

Though it has been proposed that motion and change is impossible in this One universe (Parmenides, 500BC; Zeno of Elea, 450BC), movement is probably still the best everyday example of when there is something, rather than nothing, happening in the physical world. From chemo-induced kinesis of prokaryotes to internally originated behaviors of higher eukaryotes, movement generation is a topic that has engaged scholars since the early days of science. As all questions, the question in question is fundamentally of philosophical character but has come to extend to the field of this thesis – neurophysiology – and can for the purpose of it be liberally formulated as ‘how does the nervous system translate intent to event’?

The phylogenetic fundamentality of motor and sensor systems implies that they have played an important role ontologically. The principle in its simplest analogy, even between radically different phyla seems to be the same; a circuit combining sensor and motor circuits into a functional unit, so that a stimuli induce a response that can be measured (Pettersson et al., 2003). Development of more recently conceived species has provided compartmentalized functionality, of which the neural compartment is considered to be the nearest causal source of controlling behavior. Unsurprisingly, many parts of the nervous system such as the spinal cord, brainstem, basal ganglia and motor cortices are directly implicated in sensorimotor control, but even the most remotely connected cerebral structures have been correlated to motor functions (Fetz, 1994). Whereas not classically regarded motor areas have interesting and sometimes surprising involvement in motor executions (Wayner, 1970; Matyas et al., 2010; Sawada et al., 2015; Yang et al., 2016) the primary motor areas’ involvement in the execution of movements still offer interesting revelations (Churchland et al., 2012). Studies of these have put forth ground breaking findings (Georgopoulos et al., 1986), some having resulted in fruitful real-world applications (Velliste et al., 2008; Hochberg et al., 2012). Unfortunately, to be able to make use of something does not necessarily indicate an understanding of the system that the entity takes part in, as history tells (Rorschach, 1927; Gödel, 1931; Bertolini et al., 2006; Karkanis et al., 2007). Then again, it is fortunate that a system can be practically utilized without full comprehension of it. The successful applications of BMIs, for example, comes not from an understanding of the underlying neural code<sup>\*</sup>, but rather from an understanding of how brain signals can be processed and disrupted (Benabid et al., 1987; Moritz et al., 2008; Fraser et al., 2009). That, together with a perplexingly complex brain that, in its plastic nature, can associate multimodal stimuli over multitudes of timescales, makes the possibilities for dynamic and adaptive systems harnessing signals from neurons plentiful.

Accumulated knowledge has allowed for models of various kinds to be proposed - the most implemented probably being the conductance model by Hodgkin & Huxley (1952), which’s simplicity and minimal assumptions has given it razor sharp predictive power for individual

---

<sup>\*</sup>A neural code is any neuronal signal that comes to bear meaning for the receiver of it



neurons. An intrinsic property of the neuron is to integrate incoming stimuli in order to convey a signal (or to not), depending on if the input causes the membrane potential to pass the critical threshold for the voltage sensitive ion channels in the hillock to open. This near-linear summation based “decision” is partly what enables research of the nervous system, relying on that in the logistic chain of information transfer there will be at least one neuronal correlation representing what is studied. In the highly interconnected brain there usually is. But, of course, this bears the premise that what is studied is something sufficiently distinct to be detected which is not a *modus tollens*, since the fact that something is sufficiently distinct is dependent on the evidence that it can be detected. As many arguments, this constitutes a circular one (Lærtius, 300AD), but absence of evidence is not evidence of absence and herein lies an unknown; we do not know if there exists movements that we cannot detect, and we do not know if they, if existing, have a neural correlate or not. There is thus a possibility that some of the measured neuronal activities is actually coding for events that are not (and possibly cannot be) measured or detected. Then again, the corresponding could be true also for the neuronal detection. Further, we do not know if status quo entails activity of competing motions that cancels each other out or if every action is due only to a positive precursor. Thus, much less is known about the origins of movements than about the movements in themselves, and research is motivated. Nonetheless, correlations are not always easy to find. Solely considering the sheer number of neurons in a brain makes inquiry a formidable task. Moreover, few, if any, functions are represented by individual neurons, but rather as parts of networks including thousands of neighbors at various distances from each other, distributing the neural code between them and enabling them to represent multiple functions – or parts of them (Földiák, 1990). This, on the one hand, might make it more probable to find eventual neuronal representations, on the other, might make them weaker. With current technical development enabling probing of multiple subsections of multiple regions (Ivica/Tamtè et al., 2014), scientific inquiry is becoming more elaborate and will expectedly be paralleled by the finding of more intricate neuronal representations.

Irrespective of the vast knowledge about neurons, what the principles are for generating meaning within the brain is one of the hardest problems. What has been learnt, partly from nifty sensory physiological research (Schouenborg and Weng, 1994; Ma, 2010), is that a big chunk of the information in the neural code is carried by the specific cell types – a labelled line – activated by distinct stimuli. But how the central cells are being activated with regard to which, how many, where, when, how often and their relation to each other is also important. Recent findings (Liu et al., 2012) has shed light on one of these aspects, showing that a memory engram can be evoked by mere stimulation of the subset of neurons that were involved during the acquisition/formation of a conditioned memory. These results are among the few of its kind providing evidence for the hypothesis that neuronal networks can come to bear meaning simply by reactivating them simultaneously, largely disregarding their temporal activation pattern. Relatively accurate predictions have nevertheless been made from the simple assumption that

neurons communicate with a time-dependent rate code, so that a deviation from the normal firing rate of a neuron indicates that it has some role in what is happening with the subject in a defined vicinity of that moment. This is true not only for somatosensory processes, but seems to be valid also in the case of other sensory modalities, as well as for motor processes. This commonality is expected since the networks in the brain enabling prolonged neural processing are built from the same building blocks, expanding the simple reflex circuit to connect input & output, afference & efference, sensory & motor into combinations where functions emerge (Buzsáki, 2013) that at this point cannot be explained by reductionistic determinism as has been suggested (Descartes, 1662). Consequently, from a primary neural perspective there is little distinction between what is a sensory and what is motor and along with the emergence of more complex neural processes an integrated sensorimotor expression has come to overtake the purists' nomenclature (Fetz, 1994).

In spite of the redundant, integrative and distributed nature of information processing in the CNS, early experiments employing electrical stimulation of various brain areas has implicated certain neural structures more causally linked to movement generation than others (Penfield and Boldrey, 1937). Stimulation of the motor cortices (Donoghue and Wise, 1982) and subcortical nuclei of the basal ganglia (Alexander and DeLong, 1985), have been shown to elicit muscle contractions of varying complexity in repeatable ways. Local motor cortical stimulation activates individual muscle fibers in a topographical manner, whereas stimulation of the subcortical striatal nuclei generates compound movements consisting of activations of multiple muscle fibers and joints (Vilela-Filho et al., 2014). The spinal cord is another structure that was early on proposed to serve the function of coordinating the summation of rudimentary motor components into functional compound movements – a conclusion partly following the naturalistic motor primitives evoked from spinal cord stimulation (Giszter et al., 1993). Since then, preliminary in-house results (Palmér/Tamte et al., 2012) have, together with others (Georgopoulos et al., 1986; Churchland et al., 2012), similarly indicated other pertinent structures with capabilities in line with those primary results.

In line with a Galen's hypothesis of localization of function, lesions affecting specific areas of the brain, such as strokes and/or Parkinson's disease (PD), often produce well defined symptoms. Just as a stroke-induced lesion of the M1 can produce apparent symptoms of motor dysfunction, a physical lesion of the frontal lobe can evoke alterations in personality traits (Haas, 2001). From a localization point of view, this alludes to the lost function being represented by what has been affected, but in fact tells more about the remainder of the brain's capability to cope with the loss. The two can of course coincide, and often do, as in the above mentioned case of the lesioned brain area giving rise to motoric symptoms, but it might not always. In PD, for example, the degeneration of cells in the mesencephalon, apparently affects how the natural processing of information occurs. The depletion causes a set of cardinal motor symptoms, as initially described by Sir Parkinson (Parkinson, 1817), which's severity are coherently associated to the progression of the degeneration over time - yet few would ascribe

any direct behavioral functions to any of the modulatory neurotransmitters that are lost. System effects seemingly emerge from the networks of connections in place, whose function are more properly defined by their input and output relations. Rather, then, the loss of function in this particular system might more suitably be attributed to a malfunction of the network properties, as a consequence of the neurotransmitter loss, than to any particular functions of the neurotransmitter per se.

Different networks thus pertain different functions, but determining them is not always straightforward. The distance between any given pair of neurons in the brain is on average only 6 synapses (Watts and Strogatz, 1998), hence many networks in the brain are considerably intermingled. To elucidate what functions are carried by which networks requires studies with delicate precision and sensitivity to disentangle the various variables of interest. In PD, it has been long suggested that a disruption in basal ganglia signaling explains the loss of function (Meyers, 1942). Apart from explaining features of the disease, this has also spurred studies that has led to greater understanding of the transmitter (Carlsson et al., 1957), the receptor (Surmeier et al., 1992), as well as the circuits themselves (Mink, 1996). It was early found out that replacement of the lost neurotransmitter alleviates the symptoms of the disease. At the time, less was known of what limitations the system have to utilize the supplement, and how overt adverse reactions manifesting as dyskinesia arise. Interestingly, the contextually overlooked motor cortices were recently found to offer enlightenments as to where these side effects might stem from (Halje/Tamtè et al., 2012). Even though the dopaminergic levels in basal ganglia are effectively restored, other regions of the brain affected by the systemically circulating drug seem to be sensitive at the same levels, bringing them to an altered state of processing which cause the adverse effects. With the novel methods to probe many brain regions simultaneously informational content increases to the extent where differentiations between brain states can be made that were formerly difficult to distinguish, permitting state descriptions that can be used for a plethora of purposes – neuropharmacological drug evaluations being one core purpose for the field of neurophysiology of diseases (Tamtè et al., 2016). Using this to gain knowledge about which processes in the brain are affected and guide them in desirable directions with external means is a highly intriguing endeavor of the future. Of course, biology is seldom as straightforward as mathematics, physics or even chemistry, and realizing that even microscopic parts of the system – the transmitter & receptor – are complex enough to exhibit considerable variability for the entire system, is of utmost importance.

As for now, the humble aim of this thesis has been to remove a straw of hay from the stack covering the neural principles for volitional sensorimotor control and, as nothing comes from nothing, we will continue the search for the causeless cause: the unmoved mover.

# Introduction



# Introduction

Bodies with multiple muscles and joints have countless possibilities to flexibly move about in their environment. The biceps brachii muscle, for example, works over three joints to flex the elbow and supinate the forearm and together with activity from its constituent antagonist, enables the arm to assume innumerable positions in surrounding space. The biceps is 1 of about 650 skeletal muscles in the human body and considering that natural movements generally include many, it becomes apparent that the potential degrees of freedom for these quickly rise towards infinity. How accurate control of such parameter set is achieved has for long been a major question of interest for the field.

For over a century it has been known that muscular activity can be controlled by the brain. Direct connections from both cortical and subcortical structures to the spinal cord are plentiful and provide signals that instruct the muscles to contract, producing the forces that enables movement. If the task at hand for the nervous system was merely to produce muscular contractions to allow us to move from one place to another, this could be achieved by a set of neurons of similar magnitude to the muscles. But since the number of neurons in the brain is around 1 billion times greater, it is safe to assume that the functionality it provides must be additional to that.

In spite of this massive machinery, movements do not trivially come about; a spatial goal can be reached not only by multiple routes but a given movement can also be generated by different combinations of muscles. Starting point, endpoint, direction, acceleration, velocity, etcetera, are all features that could be encoded as principles for the nervous system as movements are created. Most measurable kinematics are indeed expected to be represented somehow, somewhere in the nervous system, since they are under volitional control, and many have been shown to be (Thach, 1978; Georgopoulos, 1995). But so far, no foreseen features have been able to fully explain the corresponding measured cell activities. Either the code is more complex than assumed or it is represented by more diverse sources than individual neurons in specific regions of the brain, or, there are other, perhaps more dynamic principles than kinematics that have been overlooked. To better address the question, a system that automatically scans the full movement space continuously, allowing tracking of the trajectories of complex movements at fine detail and high speed, would help in making the detailed correlations to neuronal activity that are desired.

### *The periphery*

In essence, the purpose of the nervous system is to convey information to the organism about the surrounding world to guide purposeful behavior, which optimally should contribute to the survival of the organism. This is initially achieved through specialized receptor proteins in the peripheral nervous system that detect and respond to different sources of energy. The specific attunement of the senses that are purposeful for a given organism is arbitrary and varies greatly for different species in different environments (Novales, 2000; Heyers et al., 2007; Gracheva et al., 2010), but commonly include senses of touch, taste, smell, sight and hearing for the majority of mammals. Chemoreception of taste and smell mostly relates to food consumption, while teleoreception of hearing and vision primarily alerts of salient events in the surroundings, and they all have their separate channels of input (Craig, 2002). The exteroceptive sense of cutaneous touch, on the other hand, is perceived through the same bodily parts as those that generate movements, and is as such intrinsically tied to motor output. Mechanoreceptors detect different (vibration, pressure, stretch) direct physical interactions of objects with the body, proprioceptors detect the positions of the bodily elements, chemoreceptors detect chemical functional elements and thermoreceptors detect the kinetic energy associated with different temperatures. Upon a relevant stimulus, the receptors activate the associated nerve cell which transduces the signal, in form of action potentials, to the first central compartment involved in motor control - the spinal cord (Gerstner et al., 1997; Johansson and Birznieks, 2004).

### *The spinal cord*

Stretching along the length of the body, the spinal cord is commonly divided into a ventral and a dorsal segment, where input from the periphery enters the dorsal segment and the output to the periphery exits from the ventral segment. The dorsoventral axis is divided into anatomical laminae (Rexed, 1952), with some functional correspondence. Tactile signals enter the superficial layers that in turn have synaptic connections with the output circuits that control the muscles from corresponding parts of the body, constituting the purest form of a reflex circuit that is the basis for proper early life sensorimotor development (Pettersson et al., 2003). Early in development, repeated patterns of neuronal activity drive associations of neuronal sets through tuning of synaptic weights as the organism starts interacting with the environment (Nicoletis et al., 1996), effectively forming functionally attuned cell assemblies over time (Hebb, 1949; Bliss and Lomo, 1973). In the adult it has been suggested that similar neuronal assemblies, tightly coupled to frequently employed motor elements, may constitute building blocks for generation of more complex motor behaviors (Tresch et al., 1999). In the spinalized frog, for example, it has been shown that intraspinal microstimulation at multiple levels produce specific force fields from synergistically working sets of muscles that directs the limb to equilibrium points in three dimensional space (Giszter et al., 1993). Such neuronal sources for muscles synergies have later been shown to also be present in the spinal cord of both rodents and

primates (Tresch and Bizzi, 1999; Moritz et al., 2007). Upon simultaneous stimulation of multiple modules of this kind these primitives can be linearly combined into compound muscle synergies, simplifying the explanation of how complex everyday motor behavior may arise (Mussa-Ivaldi et al., 1994). The proposition of limited sets of flexibly combinable motor primitives is an appealing aim of reducing the longstanding issue of dealing with the abovementioned large dimensionality, but its provability by recordings has been doubted due to the confounding preceding control signal from higher structures (Todorov and Ghahramani, 2003). Furthermore, as the neuronal foundation of these suggested primitives necessarily derive from synaptic weights within the varying cell assemblies (d'Avella and Pai, 2010), the definition for when a primitive comes into existence could be just as dynamic as when two anatomically unconnected cells are to be considered functionally coupled, i.e. hard to specify. Though originally studied in the spinal cord, the existence of sets of neurons functionally tuned to specific motor output parameters have been found also at other levels of the neural "hierarchy" (Riehle and Requin, 1995), which should be expected given the underlying anatomy with dense reciprocal connections between higher structures and the spinal cord (Lynn, 1975; Dum and Strick, 1991). Thus in reciprocity with the descending signals from higher structures, inputs to the spinal cord yield ascending signals to upstream compartments of the nervous system where further processing of inputs ensue (Rosén and Asanuma, 1972).

### *Cortex*

The cortex is often exemplified as the top of the neurological hierarchy, having utmost importance for behavioral control. As a macro-structure, the cortical sheet has been subdivided into 52 cytoarchitectonically separate areas, several housing distinct function (Lichtheim, 1885; Brodmann, 1909). It is organized as a multi-columnar structure with each column having up to 6 histologically identifiable principal layers that also are believed to have specialized functionality with defined input, output and chemical relationships (Sherman and Guillery, 1996; Mountcastle, 1997). The numerous cells in the cortex are heterogeneous and the neuronal networks herein can be divided into subpopulations based on different criteria: The pyramidal cells, residing in all cortical layers, are the principal cells of the cortex and are excitatory by nature. Their counterparts, the interneurons, although outnumbered approximately by 5:1, often provide strategic compensatory inhibitory input to proximal parts of neurons' somas (Markram et al., 2004; Silberberg and Markram, 2007). Both cell types can be further subdivided into a plethora of morphological and histochemical subgroups (Spruston, 2008; DeFelipe et al., 2013), sometimes overlapping and with some functional correspondence (Markram et al., 2004). The pyramidal cells of the corticospinal tract, visualized over a century ago (Ramón y Cajal, 1899), give input to the lower motor neurons of the anterior horn of the spinal cord that in turn is in contact with muscles in the periphery (Kuypers and Brinkman, 1970). On their descending path, these often arborize extensively and send collaterals to many other systems, suggestive for a central control hypothesis incorporating large parts of the brain (Swanson,



2000). Even though it has been known for almost a half century that complete lesions to the pyramidal tract in the non-human primate produce long-lasting functional deficits in skilled hand tasks (Lawrence and Kuypers, 1968), it is still not clear what exact role it has in the execution of goal directed movements (c.f. Bjursten et al., 1976 or Merker, 2007 for puzzling revelations in different species). It is known that individual neurons in M1 has direct influence of muscle fiber contractions and are arranged in a topographical manner (Penfield and Boldrey, 1937), but how volitional control over the great number of individual neurons that would drive muscles to produce movements comes about is not fully understood. Later research has tried dismantling the topic. In a series of seminal experiments from 1986, Georgopolous and colleagues recorded the activity of populations of individual neurons from the motor cortex contralateral to the performing arm in the rhesus monkey during goal directed movements. When studying the relation of the discharge activity of the cells related to the movement, they found that the activity of the entire population of recorded cells were finely tuned to particular directions in space, in contrast to individual cells. The activity from individual cells could be represented as vectors with some weighted contribution along the preferred direction axis, but the vector sum of all cell vectors was much more sharply tuned to the direction of arm movement. Despite limitations in this interpretation (see e.g. [Loeb et al., 1996; Todorov, 2000; Fetz, 1994] for considerations), this emphasized the importance of viewing neurophysiological coordination of movement more holistically – i.e. treating the neuronal code as distributed. At the time, the field mainly dealt with intrastructural relations, but as has become evident, the widening of this viewpoint also to interstructural distribution of information has proven beneficial (Nicoletis, 2008). One of the most prominent outputs of cortex is directed to the underlying nuclei of the basal ganglia, which also are considered key actors in motor control, and have as such been thoroughly investigated in relation to it.

### *The Basal ganglia*

The nuclei of the basal ganglia (BG) are a collection of subcortical structures that process information from most parts of the cortical sheet and serve to integrate it together with subcortical inputs into multimodal loops with functional specificity (Alexander et al., 1986; Fig 1). The circuit consists of a set of mainly inhibitory nuclei that together produce a suppressing output on downstream motor centers in the thalamus and brainstem (Grillner et al., 2005). When a signal is transduced within the circuit, the output nuclei can have two effects on their targets; Inhibiting or disinhibiting (Chevalier and Deniau, 1990). The passing signal, which for the motor loop is thought to facilitate selection of motor output, is conveyed back to the source region of the "initial" signal in cortex, and ultimately funneled to downstream motor centers in the brain stem and spinal cord. The classical model places cortex at the top of the sequential chain (Albin et al., 1989; DeLong, 1990), with direct excitatory outputs to the striatum - the main input station of the BG.

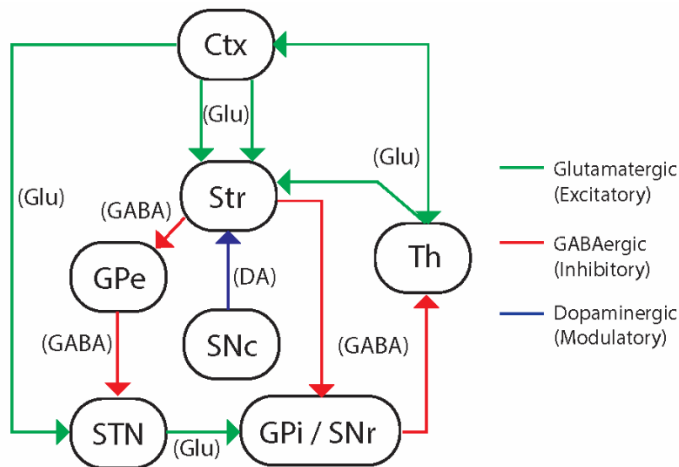

**Figure 1.** *The classical model of the Basal Ganglia.* Ctx; Cortex, Str: Striatum, STN: Subthalamic nucleus, GPi/e: Globus pallidus internal and external segment, SNc/r: Substantia nigra compact and reticular part, Th: Thalamus.

### *The striatum, dopamine and complex functions*

The striatum is made up of the putamen and the caudate nucleus and is a heterogeneous structure with distinct histological and functional compartments (Graybiel and Ragsdale, 1978; Flaherty and Graybiel, 1993; Friedman et al., 2015; Lopez-Huerta et al., 2015). Functions attributed to the striatal complex have been many, but are primarily related to reinforcement learning and action selection (Mink, 1996; Schultz et al., 1997; Wickens et al., 2003; Grillner et al., 2005). Sequence representation and habit formation are examples of functionalities that can emerge from learning mechanisms herein that are dependent on reinforcement provided by the neuromodulator dopamine (Carlsson et al., 1957; Aosaki et al., 1994; Matsumoto et al., 1999; Faure et al., 2005). Phasically delivered DA can act as an instructive signal of reward to large parts of this system and lesions to it produce learning impairments (Lindvall and Björklund, 1974; Schultz, 1998; Hikosaka et al., 2014). Despite this clear role of dopamine as a neuronal teacher its intracellular mechanisms upon receptor binding are poorly understood. Textbooks emphasize the D1-receptor family as facilitators of action potential generation through intracellular increases of cAMP via the  $G_s$  7TM receptor complex, and D2-receptor effects through reductions in concentrations of the same second messenger system, via the  $G_i$  (Gerfen et al., 1990; Purves et al., 2001). This interpretation is however generally acknowledged as an oversimplification - receptor expression in striatum is hardly dichotomous and dopamine's actions have been shown to be highly dependent on multiple factors (Surmeier et al., 1992). Basal activity of the receiving neuron, concentration and other inputs to the recipient cell are all variables that influence the dopaminergic end effect (Seamans and Yang, 2004).

Another, more empirical explanation largely disregarding the intracellular mechanisms, is that the main effect of DA on MSNs rather has to do with increasing the signal to noise ratio by enhancing their evoked firing (Kiyatkin and Rebec, 1996). Nevertheless, dopamine's indisputable role in learning is intriguing (Schultz et al., 1997). Unpredicted salient events are signalled by a short latency and duration dopamine flush so that actions leading to a rewarding outcome are behaviorally reinforced and become more likely to be expressed upon re-experiencing the same context (Skinner, 1948; Redgrave et al., 2008). The suggested neuronal substrate for this is dopaminergic reinforcement of recently active inputs by classical plasticity mechanism in striatum that DA have been shown to subserve (Calabresi et al., 2000). By this reasoning, it is understandable how the predicted reward becomes associated to the earliest conditioned stimuli predictive for it – by classical conditioning causing previously occurred events to be successively connected further back in time (Redgrave et al., 2008). Such mechanism has widespread consequences and this neuronal substrate is hypothesized to be partly responsible for both the development of action boundaries, habit formation and chunking of action repertoires (Graybiel, 1998; Jog et al., 1999; Barnes et al., 2011; Cui et al., 2013). Considering both the associative and the sensorimotor striatal involvement in sequential tasks and behaviors (Grafton et al., 1995; Aldridge and Berridge, 1998; Thorn et al., 2010), and its dynamic activation along the rostrocaudal axis in sequence learning (Toni et al., 1998), it might even be plausible that striatum is necessary for their proper encoding. Indeed there is now ample evidence suggesting striatal involvement and necessity for complex, multi-joint movements (Alexander and DeLong, 1985b; West et al., 1990), sequential action repertoires (Jin and Costa, 2010; Jin et al., 2014) and full-scale motor programs (Cromwell and Berridge, 1996). If this is the case, it would be conceivable to assume that compounds of movements could be stored in networks in striatum in a similar way to how motor primitives are proposed to be stored in the spinal cord or action sequences in the supplementary motor area (Tanji and Shima, 1994).

### *Striatal cell functions*

Finding similarities between systems is a matter of definition and similar functions have been suggested for a variety of levels (Meister and Bonhoeffer, 2001; Yuste et al., 2005), but insights from the cellular level further validates these widespread functions of striatum. The structure consists of three main neuron groups with functional specificity: fast spiking interneurons, tonically active (presumably cholinergic) neurons and medium sized, spiny neurons (MSNs) (Inokawa et al., 2010; Berke, 2011). The latter group gives GABAergic output to the downstream pallidum and constitutes up to 95% of the total cell population (Kemp and Powell, 1971). Apart from their defining morphological attributes, MSNs also have physiological characteristics contributing to their key role as integrators in their circuits. Intracellular recordings of the spontaneous activity of MSNs have revealed that these cells are characterized by their ability to stably maintain two different membrane potential levels over extended time periods. In one

state, MSNs have a more depolarized membrane potential, between around -40 to -70 mV, where inputs are processed similarly to regular neuronal standards in other parts of the brain. The other state is characterized by an overly hyperpolarized membrane potential differing up to 90 mV from the extracellular reference compartment (Wilson, 1993). In this state the cell is not prone to depolarization, which in effect reduces the influence of individual cell inputs to the system (Wilson and Kawaguchi, 1996). The main determiner of which state the cells are in has been shown to be the level of depolarizing input that they receive, which to a large extent originates from excitatory inputs from the thalamus and cortex (Calabresi et al., 1990), although dopamine receptor activation also has been implicated in the upward transition (Grillner et al., 2005). The consequence of this layout is that highly temporally coincident inputs are needed to produce sufficient depolarization of striatofugal cells, which suitably allows this cell to act as a potential screener for less “coordinated” signals. With such constrictions the organization of cortical inputs to striatal cells becomes clearer; thousands of different cells from topographical clusters in the cortex have anatomical projections to single striatal MSNs (Ebrahimi et al., 1992; Kincaid et al., 1998). This in turn explains the spiny morphology of these cells, since the system requires concurrent inputs from diverse sources for optimal transmission of a signal. Together with proposed lateral inhibition from adjacently located interneurons (Bolam, 2004) and MSNs (Oorschot, 1996), this ensures that neuronal ambiguity is weakened and only the most consistently driven signal will surpass to the next processing stations.

### *Direct & indirect pathway*

Yet another factor proposedly contributing to the rightful selection of actions is the established existence of dual routes within the basal ganglia circuitry (Purves et al., 2001). Diverging from the striatum, two pathways arise that have opposing effects on target neurons when their signals reconverge in the thalamus. The output from the BG to the thalamus is inhibitory and the direct pathway directly inhibits the output nuclei of the basal ganglia while the indirect pathway indirectly disinhibits them. Hence, the net effect of direct pathway activation is disinhibitory on a systems level, i.e. promotes signal propagation, while it is inhibitory for the indirect pathway (Chevalier and Deniau, 1990). A signal passing through the system could thus either be conveyed through the thalamus and back to the cortical areas of origin, in a more pruned form for each loop, or be inhibited (by means of the output nuclei) so that further processing and motor activation is repressed (Stocco et al., 2010). Coincidentally or not, these pathways have also been proposed to display distinct neuro-histochemical profiles, with dopaminergic receptors of contrary effects predominately expressed on each set: the D1 receptor family that presumably facilitates signal transmission is expressed on the direct and the opposing D2 receptors on the indirect pathway (Gerfen et al., 1990). Dopamine supplied through the nigrostriatal projections would by this view promote signals through the direct pathway and at the same time prevent the indirect pathway from communicating – rendering the net effect of a dopamine flush amplified. The assumption was that the two different pathways acted in

competition with each other, such that during rest the activity of the indirect pathway would prevail and during activity of the other. This hypothesis made sense not only from a physiological standpoint, but was also in accordance with the concurrent view on several disorders affecting the basal ganglia. For example, due to the opposing effect dopamine depletion would have on the two different pathways, it has been compelling to explain the main effects of dopamine related basal ganglia disorders in terms of these pathways (André et al., 2011; Miocinovic et al., 2013, further discussion below). It has now convincingly been demonstrated, that the classical thinking of direct and indirect counteraction is more complex than previously suggested; the dopamine expression profile is not dichotomous on MSNs (Surmeier et al., 1992), the projections from the striatum are not categorically divided (Wu et al., 2000) and action initiation calls for parallel activation of the system (Cui et al., 2013). As experiments like these have generated new knowledge, the early model has been revised and later schemes have tried taking some of these fact into account (Bar-Gad et al., 2003; Hammond et al., 2007; Calabresi et al., 2014; Fig 2).

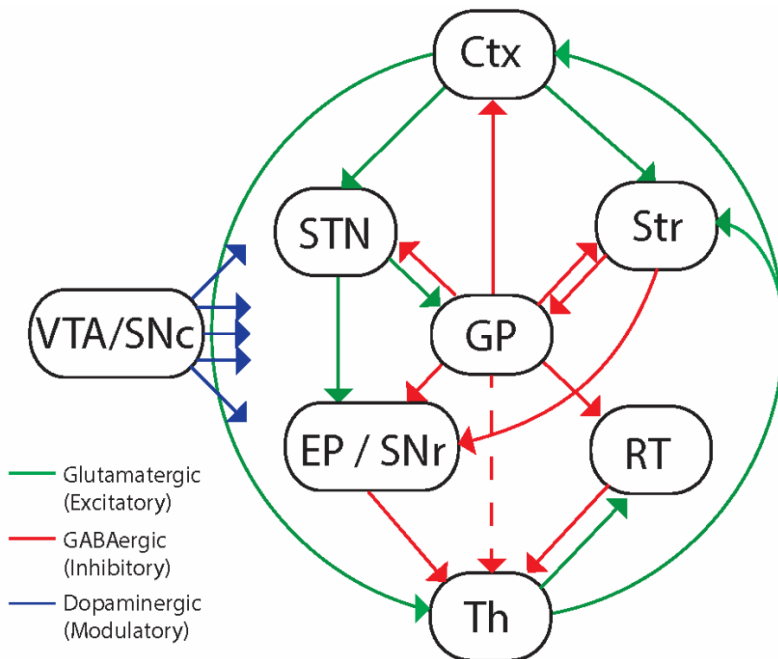

**Figure 2.** *Elaborated Basal ganglia model.* The model emphasize additional aspects of the circuitry and is adapted for the rodent anatomy. Dopamine has direct effects in all structures of the circuit. Ctx; Cortex, Str: Striatum, STN: Subthalamic nucleus, GPi/e: Globus pallidus internal and external segment, SNc/r: Substantia nigra compact and reticular part, VTA: Ventral tegmental area, EP: Entopeduncular nucleus, Th: Thalamus, RT: Reticular nucleus of thalamus.

### *Hyperdirect pathway*

Another route recognized early in the pathophysiological field was the cortico-subthalamic pathway, where lesions of the subthalamic nucleus (STN) diminished the drive of the inhibitory output to thalamus and caused severe movement effects (Carpenter et al., 1950). Though initially overlooked due to its sparse appearance, this pathway has raised significant interest with time as its influence of basal ganglia physiology has been further understood. The excitatory and somatotopically organized projection from cortex to the STN (Monakow et al., 1978; Nambu et al., 1996), known as the hyperdirect pathway, has strong influence over the output nuclei via the subthalamus, but its role in normal physiology has remained somewhat elusive. In experiments with electrical stimulation of the cortex, three phasic signals from the BG output have been detected with extracellular recordings that can be explained by classical conduction speeds through the routes in the tissue; the first, positive deflection derives from the cortical hyperdirect drive of excitatory throughput from STN widely activating the inhibitory output – thought to cause general inhibition of action; the second, negative deflection comes from the striatonigral pathway’s focal inhibition of output – thought to cause release of a specific action; the third, positive deflection originates from the subsequent striatopallidal pathway’s reactivation of STN driving the inhibitory output – thought to terminate the requested action (Sano et al., 2013). With tedious experiments in both rodent and non-human primates, a novel model focusing on the dynamic properties of the three pathways was suggested, to explain how motor programs might be controlled from these sequential activation patterns (Nambu et al., 2002; Nambu, 2004). As expected from such a wide-spanning field, more models interpreting basal ganglia function in motor behavior have been proposed (Kravitz and Kreitzer, 2012; Calabresi et al., 2014; Gittis et al., 2014; Jahanshahi et al., 2015; Mallet et al., 2016), many that will be tested in relation to the many functions of the corticobasal-ganglia system in health and disease.

### *Thalamus*

A major structure involved in multiple systems in the brain is thalamus, with widespread connections to cortical areas located both pre- (Rose and Woolsey, 1948) and post-centrally (Dempsey and Morison, 1941). Besides being the main relay nucleus for communication between the peripheral and central nervous system, thalamic nuclei also display active processing properties in its communication with cortex (Briggs et al., 2013). Thalamus has a defining role in both sensor and motor physiology, as well as for more general tuning of states that are important for normal functioning (Steriade et al., 1993; Llinás and Steriade, 2006). Interestingly, intense research in the field has suggested that glutamatergic signaling between thalamus and cortex structures might have roles different than previously suspected, displaying both modulator and driving properties within the same neurotransmitter system (Guillery, 2005; Sherman, 2005).

### *The basal ganglia-thalamocortical loop*

Apart from actively relaying peripheral input to the cortex, thalamus constitute a key node in the chain of information transfer between the basal ganglia and the cortex. The output from the basal ganglia is converged directly to select nuclei within the thalamus (Parent and Hazrati, 1995), major recipients being the ventral anterior/ventral lateral (VA/VL), Mediodorsal (MD) and intralaminar (centromedian and parafascicular; CM/PF) nuclei. In addition, strong control over the inhibitory reticular thalamus is also exerted by the GPe (Hazrati and Parent, 1991). The VA/VL nuclei of the “motor thalamus” project directly to motor cortical areas, and the BG output directed to these thalamic cells have been shown to monosynaptically inhibit them, thus having strong influence on thalamocortical transmission (Ueki et al., 1977) and motor cortical channels. The MD which has its densest projections to the prefrontal cortex in both rodents and primates (Ray and Price, 1992; McFarland and Haber, 2002), also receive direct inhibition from BG output (Ilinsky et al., 1985), linking BG processing to both early stages of motor processing and cognitive function (Middleton and Strick, 2000). The input to the intralaminar nuclei, which in turn have strong projections back to the striatum (Sadikot et al., 1992), implicate that these nuclei are part of a closed reciprocal loop with the basal ganglia. Thus in addition to the prominent cortical output from thalamus, thalamofugal system projecting to the striatum has been implicated in the physiology of the basal ganglia, which has been suggested to have distinct functionality (Smith et al., 2014).

### *The thalamostriatal system*

The main thalamostriatal output, derived from the CM/PF complex, have influence over widespread striatal regions. The PF associates most with the associative striatum while the dorsolateral, sensorimotor part of striatum receives strongest input from the CM. The cells of the latter are distinct from the cortically projecting cells in the same region (Parent and Hazrati, 1995), and there also seems to be a difference in the synaptic organization in striatum between these and Corticostriatal projections. Cortical projections to MSNs mainly synapse with heads of synaptic spines, whereas thalamic tend to synapse with the shafts (Smith and Bolam, 1990). Additionally, cortical projections mainly associate with MSNs of indirect pathway (Berretta et al., 1997) while thalamic have been shown to associate more with direct pathway neurons (Sidibé and Smith, 1996). Furthermore, corticostriatal synapses are in closer proximity to nigrostriatal terminals than are thalamostriatal, alluding to that modulation of excitatory input might be preferential for cortical inputs to these areas. This, of course, does not exclude thalamic inputs from having a strong regulatory role in this structure, but another dissimilarity is in their differential innervation of striatal interneurons. Whereas gabaergic PV<sup>+</sup> INs receive input from both systems, the putatively tonically active cholinergic interneurons only receive substantial input from the CM (see Smith et al., 2004 for a more extensive review). Although constituting a small fraction, only around <2% of the total amount of cells in striatum,

cholinergic cells have large and dense arborisations in comparison to other striatal cells, thereby having the potential to influence most striatal MSN extensively (Zhou et al., 2002). The effect of dopamine in combination with the sensory cues provided via the intralaminar nuclei, has been suggested as a basis for the proper selection of actions through the thalamostriatal system within the basal ganglia (Smith et al., 2004)

### *Cerebellum*

Though critical for regulation of behavioral output, particularly in relation to temporal aspects of motor control, cerebellum's interactions with the cortex and basal ganglia is beyond the scope of this thesis but has been reviewed elsewhere (Middleton and Strick, 2000; Cerminara and Apps, 2011).

### *Motor system disorders*

For a system subserving as many brain functions by its numerous structures, interconnections and neurotransmitters as the cortico-basal-ganglia circuit, it is easy to see how it is involved in several disorders of the nervous system (Obeso et al., 2014). Diseases range from psychiatric to motor, with both hypo- and hyperactivity disorders included in the spectra. Most studied of these is Parkinson's disease, which has been shown to be caused by the selective deterioration of dopaminergic neurons in brainstem nuclei supplying both cortex, striatum other basal ganglia nuclei with the dopaminergic drive that is required for normal functioning. Parkinson's is characterized by an inability to initiate volitional movements and a slowness of ongoing movements (Parkinson, 1817) and affects more than 1 % of the elderly population, with double rates of incidence for males (de Rijk et al., 1995; Van Den Eeden et al., 2003). While this alludes to dopamine as a substance intrinsically coupled to motor function, its central role in reinforcement should not be disregarded. Dopamine deficiency not only causes disturbances of posture and gait, but also have profound effects on motivational states of individuals, as the high comorbidity rates with depression and anhedonia in later stages of the disease indicates (Chen, 2004; Nanhoe-Mahabier et al., 2009). Nevertheless, motor dysfunction is at the core of the disease which additional symptoms confirms, as the same population of patient regularly display debilitating tremors of the extremities in the passive state (Baumann, 2012). These resting tremors express themselves as low frequency oscillating jerks most visible in the dominant arm, intensifying with progression of the disease. Furthermore, for the majority of patients the golden treatment standard with dopamine supplementing therapy cause debilitating involuntary movements within years from the time of diagnosis (Schrag and Quinn, 2000; Fabbrini et al., 2007). How these phenomena can be explained by the loss or addition of a simple neurotransmitter is to date largely unknown.



## *Predicting the unpredictable*

The classical rate model has had strong explanatory power, in for example how hypokinetic symptoms may develop from a lack of dopamine via effects on the direct and indirect pathway, producing a reduction of thalamic output due to reduced GPe (and henceforth increased GPi) output. In fact, this has been confirmed by multiple experiments over the years (Dostrovsky and Bergmann, 2004; Fuentes et al., 2010; etc). Other corroborating findings are that select optogenetic stimulation of DR<sub>1</sub>-expressing neurons actually produces hyperactivity in the intact and rescues cardinal symptoms in the parkinsonistic animal (Kravitz et al., 2010), as expected from such a layout. Hyperactivity disorders and involuntary movements could also be explained by altered thalamocortical output, caused for example by excess dopamine, where the indirect pathway would be suppressed by the supplied dopamine while facilitating the direct. Even in endogenous disorders such as dystonia such alterations have been reported (Chiken et al., 2008). In spite of these strengthening indications, the classical model has been deemed incomplete. Firstly, it relies on a straightforward and dichotomous action of dopamine at its receptors, which has been refuted (Surmeier et al., 1992; Seamans and Yang, 2004). Secondly, it fails to explain why lesions to the GPi does not cause the motor hyperactivity that such a layout would predict (Inase et al., 1996; Desmurget and Turner, 2008). On the contrary, pallidotomy in parkinsonistic patients suffering from debilitating involuntary movements induced by levodopa has been shown to reduce these (Baron et al., 1996). Thirdly, the rate model neither addresses tremors nor the muscular rigidity symptoms that most parkinsonian patients experience. Lastly, the role of dopamine in the remaining basal ganglia nuclei is not accounted for (Smith and Villalba, 2008). Subsequent explanations have tried reconciling the differences by other means.

## *Oscillations*

From the understanding of the emergent functions of multicomponent systems, more abstracted features than direct neuron to neuron interactions are currently being investigated in relation to normal and disease phenomena. Groups of neurons together exert changes in the surrounding electrical field, known as the local field potential (LFP). Similarly to the EEG-signal, field alterations caused by the collective actions of neurons synchronize large amounts of neighbouring cells producing fluctuations in the extracellularly measured voltage. Whether just a conveniently measured epiphenomenon of classical firing or not, field oscillations has been convincingly correlated to a plethora of functions (Buzsáki, 2006), and has the benefit of measuring the collective action of thousands of cells with high spatiotemporal resolution (Mitzdorf, 1985; Logothetis et al., 2001). Coherent fluctuations of given rhythmicity, i.e in particular frequency bands, act as communication channels for functional binding between separate parts of the brain (Fujisawa and Buzsáki, 2011). As normal function rely on correct control of such information channels, both the lack and the excess of oscillatory components in

the LFP of various brain regions have been associated with diseases (Llinás et al., 1999; Brown, 2003; Costa et al., 2006). The basal ganglia layout with multi-directional connections controlling the inhibitory/excitatory balance over large areas in the brain could be particularly prone to oscillate (Brown et al., 2001; Dostrovsky and Bergmann, 2004). In line with this, it has been suggested that different oscillations in the basal ganglia circuitry might contribute, or even be causally linked to pathological motor symptoms like akinesia and tremors (Deuschl et al., 2000; Richter et al., 2013). Excessive oscillations in the beta-range (15-35 Hz) in striatum and other parts of the circuit during passive states are indeed descriptive for the akinetic periods of Parkinson's, and has been proposed as a biomarker for inactivity in both health and disease (Berke et al., 2004; Kühn et al., 2009; Quiroga-Varela et al., 2013; Toledo et al., 2014). Aberrations in low-frequencies, in the theta range (4-10 Hz) have also been implicated in disease states (Alonso-Frech et al., 2006), as have higher gamma (>35 Hz) bands (Staba and Bragin, 2011). The link between oscillations on tremors, on the other hand, has not been as convincingly demonstrated, though speculations of common resonance frequencies in neural networks and behavior have been plentiful (Levy et al., 2000; Raz et al., 2001; Quiroga-Varela et al., 2013). Despite intensified research, important questions of how oscillations in cortico-basal ganglia circuits contribute to the executions of movements in health and disease remain (Nambu, 2008; Mathai and Smith, 2011). Many will require combinations of techniques to be answered, and collecting broad-band information from the full circuit will be favorable.

### *Treatment effects and adverse reactions*

Alongside symptom reduction, excessive beta oscillations associated with parkinsonism are readily alleviated with the gold-standard medication for the disease – levodopa (Brown et al., 2001). Levodopa is the immediate precursor of dopamine in the synthesis chain, and is selectively converted to dopamine by neurons expressing the converting enzymes DOPA and aromatic amino-acid decarboxylase. As expected, many of these are dopaminergic neurons but with their successive degeneration the therapeutic window narrows and other systems become involved in DA transmission. Both norepinephrinergic and serotonergic cells have the capability of synthesizing monoamines from amino-acid precursors, and have been widely recognized in the pathology (Hökfelt et al., 1984; Tanaka et al., 1999). Upon delivery of levodopa, plasma and intracerebral concentrations rise and supplement the system (Carta et al., 2006), but with progression of the disease it becomes progressively harder to maintain stable effects without eliciting side effects. Peaks in drug concentrations lead to involuntary excessive movements, referred to as levodopa-induced-dyskinesia (LIDs), which are greatly incapacitating for the affected individual (Weiss et al., 1971; Dodel et al., 2001). The corresponding molecular alterations are multifaceted, but primarily relate to upregulation of dopamine's postsynaptic effects that is caused by compensatory cell changes in response to the dopamine deprivation (Cenci and Konradi, 2010; Francardo and Cenci, 2014). This has been extensively studied in the striatum, but could potentially extrapolate to other sites of action as

well. Another influential theory emphasizes the serotonergic system as a key culprit; upon levodopa administration, serotonergic terminals take up the drug and converts it to dopamine, colocalizing it with serotonin in the vesicles. When a signal calls for drive of serotonergic output, dopamine get flushed to the system without regulatory control (Carta et al., 2007). Serotonergic terminals do not express presynaptic dopamine autoreceptors, rendering serotonin, with reduced content per vesicle, determinant of the release of dopamine. This unsupervised release has been causally linked to LIDs - presynaptic stimulation of serotonergic autoreceptors has effectively reduced dyskinesia in both animal as well as humans (Kleedorfer et al., 1991; Muñoz et al., 2008; Rylander et al., 2010; Svenningsson et al., 2015).

For the cardinal symptoms of Parkinson's disease, many molecular abnormalities in the BG have electrophysiological counterparts, but if and how other parts of the brain could relate to these symptoms has been largely overshadowed by the direct focus on the basal ganglia network. In the late 1990's, a clinical study measuring regional blood flow was among the first to find that precentral cortical regions appeared overactive in the dyskinetic state, rising the potential for structures outside of the basal ganglia to be considered in the pathology (Rascol et al., 1998). Since then, these results have been corroborated by animal studies, having found direct neurohistochemical alterations in primary motor areas during dyskinesia (Ostock et al., 2011). If indeed cortex is involved in the expression of LIDs, finding an electrophysiological marker of this disease state could prove highly beneficial. Such a signal could be directly utilized in future studies if sufficiently strong and robust, but could also serve as a biomarker and constitute a new drug target for the disease.

### *Future treatments*

Needless to say, major needs for treatments against these and other diseases affecting the brain remains. Unfortunately, drug development for diseases affecting the central nervous system has consistently declined over the last couple of decades (DiMasi et al., 2010), having resulted in drastic increases in development costs. Reasons are plenty but can be reduced to three primary factors: firstly, drug delivery across the blood-brain barrier constitutes a CNS-unique consideration for the bioavailability of the chemical entity, putting constraints on the chemical development. Secondly, drugs delivered to the target via the bloodstream often trigger side-effects due to the non-specific action at other sites in the homogenous target tissues, which can render otherwise effective treatments unviable. Thirdly, the understanding of the physiological processes underlying health that are affected in disease is incomplete, making interpretation of drug effects difficult. As one of the founders of modern day drug discovery puts it "If it were simple to ascertain the properties required to develop a lead discovered in vitro to one that is active in vivo, drug discovery would be as reliable as drug manufacturing" (Lipinski and Hopkins, 2004). A mixture of techniques, combining the in vitro and in vivo setup will expectedly be required to attain the answers needed for future advancement.

## *Animal models*

There are many examples of experiments better suited for ex vivo studies, but with the many unknowns of the in vivo setup that to date cannot be modelled solely by analysis of the tissue, the drug development process are still in need of the empirical knowledge gained from the in vivo setup. Animal models are thus required to study diseases, but so is awareness of their limitations. Animal models have been chosen to replicate certain disease relevant features and behavioral measures are applied in assessment of the disease. The interpretation of animal behavior is often based on standardized scoring of motor activity, which is motivated for diseases affecting the motor apparatus, but can be problematic for diseases with covert symptomatology, e.g. psychiatric conditions (Nestler and Hyman, 2010). Thus motor diseases can often be reliably modeled and the rat model of levodopa-induced dyskinesia is one example of such (Cenci et al., 2002). In this model, the medial forebrain bundle, containing the axons that supply most of the endbrain with dopamine (Uhl et al., 1985; Björklund and Dunnett, 2007), is severed by injection of a dopamine analogue with neurotoxic properties (Ungerstedt, 1968). Abnormal involuntary movements (AIMs) are elicited by resupply of dopamine to the system and is evaluated by standardized scales, measuring their prevalence (Lundblad et al., 2002; Cenci and Lundblad, 2007). To date, this is one of the mostly applied methods of evaluating dyskinesia, for good reasons. The scale is standardized and well evaluated, easy to apply and well adapted to the symptoms displayed by the animal, which are also similar to the human counterpart. For drugs that theoretically can (and often do) affect any system within the brain however, general effects can be difficult to evaluate without taking other behaviors into account. A given treatment could by virtue of reduction of AIM-values and a dynamic dose-response be interpreted as a good candidate drug if merely based on the dyskinetic symptoms, even though other symptoms outside the measured dimension could arise. This potential issue generalize to rating scales of many diseases, for understandable reasons: assessing diverse drug effects with a scale that is primarily adapted for measuring severity of a predefined set of symptoms risks losing important aspects of the treatment. Indeed, surrogate endpoints are most informative when described holistically, which was recently demonstrated in the dyskinesia field when comparing multiple behavioral assessments scales in the human (Goetz et al., 2013). It was there established that the UDysRS, which was the scale utilizing the highest number of effect-dimensions, was superior in demonstrating effects in dyskinetic patients treated with the only drug currently approved for the treatment of levodopa-induced dyskinesia.

## *Biomarkers*

Finding more dynamic and objective correlates of disease and effects would therefore be preferable and endogenous signals are good examples of such. In the field of medicine, wet biomarkers have for long been central for interpreting effects of treatment, ranging from CRP in blood for general infections to troponin in the spinal fluid for stroke. Examples of dry

biomarkers also exist. In epilepsy for example, the disease state is describes as an excessive neuronal synchrony that cause oscillations in the field potential that can be measured with electrophysiological techniques such as the EEG from the scalp (Staba and Bragin, 2011). Although the mechanism for the generation of these vary and/or are not entirely known, impeding this hypersynchronous state correlates strongly with symptom reduction. Nevertheless, stopping the epileptic oscillations does not necessarily warrant a successful treatment, since additional effects also could be induced. It would therefore be of value to also have correlates of desired outcome, i.e. a marker of normal behavior that could be matched to the effects of a drug in addition to the ablation of the biomarker of disease symptoms. In this way, drug effects could be evaluated on dual grounds. Firstly, by reduction of symptoms or other surrogate endpoints, and secondly by the induction of normal behavior or surrogate measures of it; two not necessarily overlapping measurements. A system utilizing these different dimensions together would fulfill crucial needs for CNS drug development and would presumably help shorten the path from the laboratory to the clinic for a drug under development.

**AIMS**



# Aims

- I.** To develop an automated system for high resolution behavioral tracking of motor components in neurophysiological research.
  
- II.** To assess the role of the corticostriatal network during Parkinsonism and levodopa-induced dyskinesia.
  
- III.** To construct an electrode enabling adaptable targeting of multiple brain areas for electrophysiological recordings in freely behaving animals.
  
- IV.** To develop a method to utilize large scale neuronal signals as biomarkers for internal states correlated to health and disease.





## Material & Methods



# Material and methods

Confer original articles (appendix) for detailed description of individual studies.

Adult Female Sprague-Dawley rats were used in all experiments. Animals were kept in a 12-h light-cycle and received food and water ad libitum, except for in (I), where food deprivation 22h before each experiment was applied. Approval for the experiments was obtained in advance from the Malmö/Lund ethical committee on animal experiments.

## Experimental techniques

### *6-Hydroxydopamine lesions (II, III, IV)*

Rats were anesthetized with Fentanyl/Medetomidine (0.3/0.3 mg/kg, i.p.) and stereotaxically fixated with the cranium positioned horizontally. Each lesion entailed two injections of 6-hydroxydopamine hydrochloride (3.0 µg/µl free base) in 0.02% ascorbate saline solution into the medial forebrain bundle of the right hemisphere at the following sites in relation to bregma and the cortical surface: Injection coordinate 1 (2.5 µl): tooth bar (TB): -2.4 (mm), anteroposterior (AP): -4.4, mediolateral (ML): +1.2, and dorsoventral (DV): -7.8. Injection coordinate 2 (2.0 µl): TB: +3.4, AP: -4.0, ML: +0.8, DV: -8.0. Animals were left to recover for 1 week, while symptoms appeared. After 1 week, daily levodopa injections (10 mg/kg) were made to prime dyskinesia. Motor impairments such as asymmetric gait and posture as well as reduced forelimb dexterity appeared within 2 weeks after lesioning. Only animals with manifest dyskinesia at a levodopa dose below 15 mg/kg 2 weeks after lesioning were included in the study.

### *Electrodes (I, II, III, IV)*

33 µm insulated tungsten wires were arranged into arrays with 250 µm spacing between wires, targeting either only the corticostriatal (I, II) or the cortico-basal ganglia circuit (III, IV). Each array consisted of a suitable number of recording channels depending on target size (range 5-16) and at least one reference channel per structure. Individual wires were cut to a length corresponding to the specific recording site, with a 45 degree angle to optimize surface area. Reference wires were cut slightly shorter and were deinsulated at the tip, placing them in cell sparse areas adjacent to the recording site. The wires were attached to electrical connectors with conducting epoxy, and linked to the acquisition device via custom made adapters. Ca 4 screws were attached to the skull of each animal for attachment of the electrode with dental cement to the skull. 200 µm silver wires were connected to the electrode and the skull screws to electrically ground the animal.

### *Electrode Implantation Surgery (I, II, III, IV)*

Electrodes were sedated with Fentanyl/Medetomidine (0.3/0.3 mg/kg, i.p.). Animals from all experiments were implanted with electrodes in the forelimb area of the primary motor cortex (AP: +1.5, ML:  $\pm$ 2.8, DV: -1.0) and corresponding areas of the dorsolateral striatum, (AP: +0.2, ML:  $\pm$ 3.8, DV: -4) in both hemispheres. In study III & IV, the following structures were also targeted: Rostral Forelimb area (AP: +3.75, ML:  $\pm$ 2.0, DV: -1); Dorsomedial striatum (AP: +0.2, ML:  $\pm$ 2.8, DV: -4); Globulus pallidus (AP: -1.0, ML:  $\pm$ 3, DV: -6.5); Ventrolateral/Ventroanterior nuclei of thalamus (AP: -2.6, ML:  $\pm$ 1.75, DV: -6.5); Subthalamic nucleus (AP: -3.5, ML:  $\pm$ 2.3, DV: -7.5-8.2); Substantia nigra pars reticulata (AP: -5.4, ML:  $\pm$ 2.4, DV: -8.2).

Tested drugs were administered intraperitoneally except for in animals receiving pharmacological intervention in study II, where a microdialysis cannula was implanted around 1.5 mm in front of the motor cortex of the lesioned hemisphere to allow for topical administration of drugs. The dura was locally removed and the tip of the cannula was placed superficial to the cortical surface, assuring that the injected volume would spread to the recorded area. Implants were fixated with acrylic cement attached to the screws in the skull. The anesthesia was reversed (Atipamezole hydrochloride, 5 mg/kg, i.p.) and postoperative analgesic was administered after the surgery (Buprenorphine, 0.5 mg/kg, s.c.). All animals were left for one week to recover after implantation before experiments were initiated.

### *Experimental setup*

#### Study I:

The reaching apparatus consisted of a transparent 45×15×35 cm (l/w/h) Plexiglas cage with an aperture at the middle the short side 40 mm above the ground. A 30 mm deep shelf was placed outside the aperture for the placement of food pellets, with three indentations 15 mm from the edge of the aperture. The middle indentation was positioned in front and the other two pockets 6.5 mm laterally on each side of the middle. By this configuration the rat was only able to acquire pellets with the forelimb contralateral to the lateral pockets (see Whishaw and Pellis, 1990 for details). The rat was placed in the reaching box setup to reach through the aperture for small pellet rewards. A trial ended upon successful acquisition of the pellet by one or more attempts, or if the pellet was moved from its position in the indentation, in which case it was removed by the operator. The rat returned to the opposite end of the cage before presented with another food pellet, requiring the animal to reposition before each trial. At certain trials the food was withheld so that the rat was forced to identify the presence and location of a pellet prior to reaching, increasing the accuracy of each reach.

## Study II, III & IV:

Animals were placed in a 250 mm diameter transparent cylinder as their behavior was recorded with a digital camera triggered via an TTL pulse generator. The paradigm was as such: A 30 min baseline period was recorded after which the rat was injected with levodopa and benzerazide. Within 10 to 20 min the animals had manifest dyskinesia, which reached peak severity around 1 h later and recordings continued until the dyskinesia diminished (around 2 h post levodopa injection). In study II, either a dopamine receptor type 1 antagonist or vehicle (saline) was injected through the implanted guide cannula to the cortex at 60 min post-levodopa injection (peak dyskinesia), using a Hamilton syringe. Recordings continued for 60 min after topical injections. In study IV, amantadine, levetiracetam, diazepam and 8-OHDPAT and its antagonist WAY-100,635, were injected i.p. at a time chosen to have effect during the time point of peak dyskinesia.

### *Dyskinesia scoring (II, IV)*

Scoring of dyskinesia was done according to standard off-line scoring methods of abnormal involuntary movements (AIMs; Cenci and Lundblad, 2007). Orolingual, forelimb, and axial dyskinesia were scored on a scale ranging from 0-3 with respect to dyskinesia severity, for monitoring periods of 1 minute every 5 minutes. In addition, rotational behavior was also scored in the same manner, as it is correlated with general dyskinetic symptoms in this model (Breger et al., 2013). In the scoring, zero equals no dyskinesia and three equals continuous dyskinesia. The different AIMs were then added together to produce a “total AIM value” for each scored time point, which indicated the overall severity of the dyskinesia at any given time (Figs. 6 & 8B).

### *Tissue preparation and TH staining (II)*

Rats were given a sufficient dose of levodopa and benserazide to elicit robust dyskinesia before perfusion. At the time of peak dyskinesia, rats were injected with a lethal dose of pentobarbital and were perfused with saline, followed by cold PFA. After fixation, brains were explanted and fixated in PFA overnight and transferred to a 4°C sucrose solution in PBS for cryoprotection after which they were sectioned in coronal sections of 30 μm thickness. Sections were stored in anti-freeze solution at -20°C until staining was done. Lesion levels were estimated by TH-IHC. Briefly, sections were washed in potassium PBS to rinse the antifreeze. Sections were then quenched in H<sub>2</sub>O<sub>2</sub> and MetOH in KPBS. Subsequently, the sections were incubated in normal goat serum (NGS) in KPBS with Triton X-100 (KPBST), followed by incubation with primary anti rabbit anti-TH at 4°C overnight. Next day, sections were rinsed and incubated with the biotinylated goat anti-rabbit diluted in NGS and KPBST. Thereafter, the sections were incubated at room temperature for 1 h in avidin-biotin-peroxidase solution. The antibody binding was detected by using 3,3'-diaminobenzidine and H<sub>2</sub>O<sub>2</sub>. For TH quantification, photos of the individual sections mounted on a Kaiser slimlite light box were

taken with a digital camera under similar illumination levels. The optical density of TH-immunoreactivity was calculated using the NIH ImageJ program according to standard methods at the two AP-levels (-0.2 mm and +1.5 mm). For whole section TH-quantification the optical density of the cortex was used as an estimate for background level TH staining and was subtracted before calculations of side differences, given as percentage of TH of the intact side.

### *c-Fos and D1R staining (II)*

Immunofluorescence for *c-fos* and D1R was done in accordance with previous protocols. Sections were rinsed in PBS washed twice with Tris buffer. They were then incubated in NGS in PBS with Triton-X (PBS-T) for 1 h. Following overnight incubation at room temperature with either rabbit polyclonal antibody (*c-fos*) or rabbit polyclonal antibody (D1R), antibodies were detected by Alexa Fluor 594 goat-anti-rabbit. *c-fos*-positive cell counts and D1R-density was estimated by confocal laser scanning microscopy of the fluorescent sections. The analysis was limited to the sections along the implanted sites and identical acquisition settings were used for both hemispheres without post acquisition adjustment differences between sides. Images were made bichromatic before quantification. The analyst was blinded to which hemisphere samples were taken from, and quantified samples through manual thresholding of fluorescence intensity. The number of cells showing fluorescence above the threshold levels was counted for *c-fos*, whereas for D1R the number of pixels were used as readout.

### *Acquisition of electrophysiological signals*

Extracellular signals were acquired and digitized at 32 kHz using a multichannel recording system with adapted software (Neuralynx/Cheetah). Threshold for storage of spiking events was set to three standard deviations of the raw signal. LFPs digitization was sub sampled to 1017 Hz. The cables were attached to a multi-channel commutator to allow the animal to move freely in the experimental environment as LFPs and unit activity were recorded. Action potentials were bandpass filtered between 600 and 9000 Hz (I, II, IV) and local field potentials between 0.1 and 300 Hz (II, III, IV) and stored for post hoc analyses.

## **Analytical measures**

### *Spike sorting (I, II, IV)*

Recorded waveforms were sorted manually offline. Features used for clustering were valley and peak amplitude or the first three principal components of the waveform vectors. After sorting, units were classified as single- or multi units based on violations of the inter spike interval threshold, set to 1.6 ms, approximating the refractory period of a generic neuron. If less than 0.1 % of the spikes of a cluster violated the threshold the cluster was classified as single unit (SU), otherwise as a multiunit.

### *Cell classification (I, II, IV)*

Based on waveform features (valley & peak width and peak-to-valley time), SUs from striatum and motor cortex could be classified into either of two cell types per structure. The widths were defined as the width at half of the maximum amplitude. Cortical units were classified as either pyramidal cells (PC) or interneurons (INc). Striatal units were classified as either medium spiny neurons (MSN) or interneurons (INs). SUs with a probability of membership  $<0.75$  were labelled as unclassified if the probability of membership to a class was less than 0.75 by fuzzy k-means clustering.

### *Firing rate modulation (II, IV)*

Firing rates estimated with 10 s bins were evaluated by comparing rates during dyskinesia with rates during the baseline condition. Periods with rates  $<0.1$  Hz (in 1 min windows) were excluded from the analysis. The firing rate distribution of the baseline was compared with the dyskinetic distribution and was deemed significantly modulated when  $p < 0.05$  (Mann-Whitney U test). Differences in the amount of modulated cells between the intact and lesioned hemispheres were then tested with a two proportion z-test (with a significance level of  $p < 0.05$ ).

### *Time-frequency analysis of LFP power (II, III, IV)*

For an experiment recording LFPs, a spectrogram calculated in 8 second bins with a Hann window with 50% overlap using Welch's method, was estimated using custom written code in Matlab (MathWorks) (see Fig 6 for example input traces from individual electrodes). To detect and reject artefacts, a flatness criteria of the thresholded median variance over a 0.1 s window was used. Powerline noise components (50 and 100 Hz) were removed from the PSDs using a notch filter. Spectrograms from all functional electrodes within a structure were averaged to generate one mean spectrogram for each structure. Time-averaged power spectral densities (PSD) for different experimental periods were obtained from these spectrograms and each PSD time series was averaged over a certain frequency band to obtain the average power of that band for a given set of experiments. By normalizing the PSD time series to the estimated mean power of the pink noise background from the same experiment, high-resolution time-frequency plots of spectrograms could be shown (indicated by the unit dB pink, e.g. Fig 6). The resulting spectrograms were smoothed along the frequency and time axes with an eight- and three-point moving average, respectively, giving a resolution of  $\sim 0.12$  Hz and 16 s.

### *Pink noise estimation (II, IV)*

The noise background was estimated separately for each channel and each 8-s window. The pink noise like background signal was assigned to the power of the frequency bands where the PSD followed a  $1/f$ -like trend, in order to better identify oscillations in certain part of the frequency spectrum. When the complexity of the data prohibited manual picking of enough



frequency bands with pure pink noise to get unbiased estimates of the noise background we instead divided the frequency axis (1 - 200 Hz) into 20 logarithmical bands (1-1.3, 1.3-1.7, etc) and automatically fitted the pink noise power curve using the median power of each band. Deviations from the pink noise floor could then be described in terms of the dimensionless unit dBpink. Finally, for each individual LFP time series, average spectrograms were calculated for each structure, based on the normalized spectrograms (e.g. Fig 6). In order to obtain spectra for different states, the obtained spectrograms were averaged over the period of each behaviorally classified state.

#### *Creating systems level neurophysiological states (IV)*

In order to create a neurophysiological state description from the global recordings we condensed the multidimensional data to capture the main variance in a reduced set of dimensions. For details, see results section.

#### *Quantification and classification of state separability (IV)*

To visualize the separation between states in terms of classification performance dimensionality of the data was first reduced using principal component analysis (PCA). PCA performs a rotation of the high-dimensional coordinate system such that the variables in the new coordinate system are uncorrelated. The first variable in the system is the first principal component (PC1), and captures the most variance of the dataset, PC2 captures the second-most variance in an orthogonal dimension to the first, and so forth for the subsequent PCs. A representation of the dataset in the two-dimensional plane for these two components would automatically create the plane in which the data is most spread out, visualizing the high-dimensional data in a way allowing for convenient identification of clusters. To quantify the separation between states a Gaussian mixture model was fitted to the data after the dimensionality reduction, with the number experimental conditions (e.g. control, control+levodopa, PD and Dyskinesia) setting the number of Gaussian components. Starting conditions (means, covariances and mixing proportions) for the optimization were calculated by assigning samples to one Gaussian component from each experimental condition. The separability of states within the model could be estimated by assigning each sample to the Gaussian component with the largest posterior probability and calculating the amount of correct classifications. Chance level corresponds to  $p = 1/3$  for classification between the 3 different states (Control, PD, Dys), and  $1/8$  when the five drug induced states were also included. Classification performance generally improved with more principal components. Only the first 30 principal components (capturing >99% of the variance in the data) were used in classification performance quantifications. In additional tests, the data of each possible state pair was projected onto a line projected through the means of their distributions creating two sets distributed in 1D, that were tested with a standard frequentist test corrected for multiple comparisons (Bonferroni), with a significance level of  $p < 0.05$ .

## Results & Motivations



# Results and motivations

## Study I

“On the analysis of movement in neurophysiological research”

### *Defining the behavioral paradigm*

To enable detailed study of the neurophysiological principles behind motor behavior we sought to develop a tracking-system with high spatial and temporal resolution output, to correlate with the very local, millisecond scale measurements acquired from the neuronal recordings. To be able to test, and show the potential benefit of such system we required a complex yet practical behavioral model. Practicality would be met by being able to use the well-studied and inexpensive rodent as a model. In addition, the behavior would be complex, i.e. consist of multiple variables to relate to the neural signals. Though potentially making interpretations more difficult, it is generally the case that the more variables a correlation is derived from and validated against, the stronger the hypothetical link. Additionally, the analyzed behavior should have a long enough duration to allow for integration of neural signals over reasonable time scales; if not per trial, then at least when pooling a reasonable amount of trials. Still, as many everyday movements occur in high speed, the velocity of the movement also would have to be considerable. Although small movements with little complexity are desirable because of their reliable repeatability, we would need to utilize the maximum amount of space for a given movement to be able to link the two parameters of speed and duration. Hence the distance of the movement should be taken into account.

### *The reaching setup*

The reaching and grasping behavior employed by the most plantigrade animals with volitional control over their limbs, fulfills most of the abovementioned needs. Having a sufficient size for the electrodes and a relatively fast learning ability in motor tasks, the rat was the animal of choice. The neural areas recorded from were chosen based on the literature, having shown involvement of both dorsolateral striatum and primary motor cortex in goal directed reaching in other animals (Fetz and Finocchio, 1975; Nicoletis et al., 2003; Wächter et al., 2010). Reaching in this animal has been characterized extensively with regard to the behavior (Whishaw and Pellis, 1990), which is beneficial for electrophysiological relations to the behavior. In short, the behavior entails the animal making a directed limb movement in space, grasping a food pellet and then retracting the limb to the starting point to consume the food reward, highly relatable

to the human equivalent of reach and grasp (Klein et al., 2012). In detail, the behavior is characterized as multi-componential in that the lift off, advancement and alignment of the paw and subsequent grasping of reward and retraction of the limb, are all uninterruptedly executed as one and display relatively minor variability (Whishaw et al., 2008). Following a one week learning course the animal approached asymptotic levels (measured by rate of successful trials). At that point the animal swiftly approached the front part of the box, aligned its body, identified the presence of the reward, stretched out the dominant paw through a slit to the outside of the box, grasped the reward from a shelf and retracted the paw again, a process that on average takes less than 300 ms. Having multiple indentations in the outside shelf, adaptable positioning of the pellet with respect to paw dominance, distance and other variables were possible to adjust accordingly. The behavioral setup was chosen so that the behavior could be recorded with at least two externally placed cameras to track the behavior, synchronized to the neuronal recordings with an external pulse generator. In order to be able to fully describe the kinematics of the movement, knowledge about the position of the individual joints of the paw and arm was key. To attain such a description of the movement we aimed to construct an in-silico model of the paw using multiple parameters chosen based on the underlying anatomy. The ambition was to be able to automatically estimate the location and position of the rat paw in three dimensions from the attained camera recordings. Therefore, the 2D images attained from the two cameras were supplemented by placement of 3 mirrors surrounding the movement space, creating a total of six complementary projections that captured variations along all spatial dimensions. To ensure maximal fidelity, 200 frames per second were recorded from each camera, generating a total of 1200 complementary projection views of the movement per second, corresponding to six every fifth millisecond.

### *The paw model*

The paw model was comprised of thirteen elements, of which one represented the palm and the other 12 represented the phalanges, with each digit having three elements (the minor rodent equivalent of a thumb was not included). Each element was a virtual ellipsoid joined to the adjacent element(s), corresponding to bodily bones and joints (Fig 3). The model thereby had a total of 19 DoFs together defining the movements of the paw. Paw pose estimation was done by adjusting the orientation of the individual elements arounds the axes of adjacent joints, and projecting the combined pose onto the respective image planes of the complementary images. The model pose producing the smallest matching quality error between the projection of the model and the images, based on two different quality measures, was chosen for each set of images corresponding to a given point in time. The process was then iterated for each set of images during a trial, producing a trajectory describing the relation of all parameters with high spatial and temporal resolution. The two quality measures were silhouette and edge matching, where the silhouette measured how well an image silhouette was described by the model pose, and the edge measured how well the image edges were described. The individual image quality

values per set were averaged to produce a composite value for each quality measure, and the product of the two measures that generated the smallest error was chosen as the optimal pose for each image set. The pose estimation was done in the following manner: A first pose was chosen from a database with commonly encountered poses. Following poses derived from the preceding pose. The calculation was reduced by generating a flexion/extension interval over 2 joints at a time for one digit at a time. For each generated hypothesis, the fraction of the three bone elements overlapping with what is classified as the paw in the images was calculated. If the value was below a chosen threshold, the hypothesis was discarded. For the non-discarded hypotheses, silhouette and edge images were generated for the digit from the 3D model. Each silhouette and edge image was evaluated based how much of these that were corresponding to the silhouette and edge from the image(s) of the rat's paw, the X best hypotheses were saved. The process was repeated for each digit and iterated until the total matching quality did not improve, where the best combination was chosen as the result.

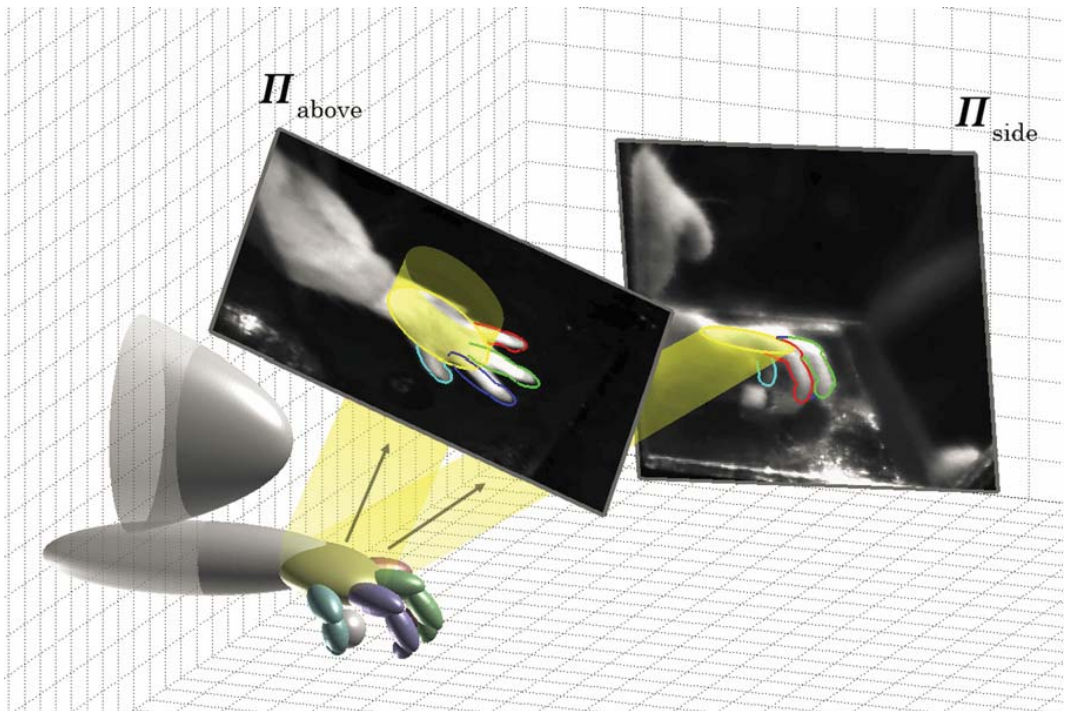

Figure 3. *Paw pose estimation principle*. The rat in silico paw model is outlined to the left in the illustration. 2D projections of the 3D forepaw model are fitted to the six different image planes (two example planes shown in figure). The pose is inferred based on the matching quality between edges and surfaces of the projections to the different planes. Coloured silhouettes in the image planes indicate calculated projections from the model.

To get an estimation of the reliability of a pose estimation, ground truth information is required which is not available in the freely behaving animal. Instead, we used a rat forepaw with fixed joint angles. A high resolution visual hull of the paw was calculated separately from a large number photos from different angles. The fixated paw was then maneuvered in as realistic a trajectory as possible over the same setup as the rat was performing, recorded and processed according to the description above. By manual fitting of the 3D model to the visual hull, the calculated deviation was on average only  $2.4\pm 2.4\%$  compared to the reference pose of the full movement range for each joint, which corresponded to the 5 pixels in the camera resolution, which in Cartesian metrics was in the order of  $0.29\pm 0.22$  mm. The automated system was deemed adequate and was utilized in an example set of experiments to estimate its practicality.

### *Components of the behavior*

In compliance with earlier movements classifications (Tresch et al., 1999), the reach and grasp movement has been proposed to be made up of distinct subcomponents: (1) Advancement, (2) Arpeggio, (3) Grasping and (4) Retraction. In an attempt to study if these subcomponents of the compound movement has a neuronal correlate in our recorded circuit, we averaged the 19 DoF parameter differences between start- and endpoint for each of these components. This generated four (19-dimensional) movement vectors corresponding to the joint movements of each phase. With retraction considered as negative advancement, a description of the full reaching and grasping movement by three vectors was made possible that could be visualized in a 3D-plot and related to the simultaneously recorded neuronal dataset.

### *Neuronal coding of motor components*

As individual trials differed slightly with regards to the expression of the movement, each motor component actuation was normalized to its full distance and expressed as a fraction of the full move, to be comparable with other components of the same type. Within an interval of -500 to 200 ms from the reference point in time where the paw was maximally extended, 35 % of the 83 recorded single units were task related. For this set, we wanted to search for modulation in relation to the actuation of each component and thus divided the trials of each motor components into three equally large groups, based on the maximum value of each component before normalization. A specific trial could e.g. consist of an advancement that was classified into the “low”, an arpeggio in the “high” group and a grasp in the “middle” group. For all reaches and single units, we found that 11%, 13% and 10% of the SUs were significantly modulated in relation to these components, respectively, as demonstrated by the example cells in Fig 4. This demonstrated that the developed system neatly allows for the correlation of kinematic sub-components of movement to neuronal recordings, to be utilized in future studies on how these circuits properly encode motor commands.

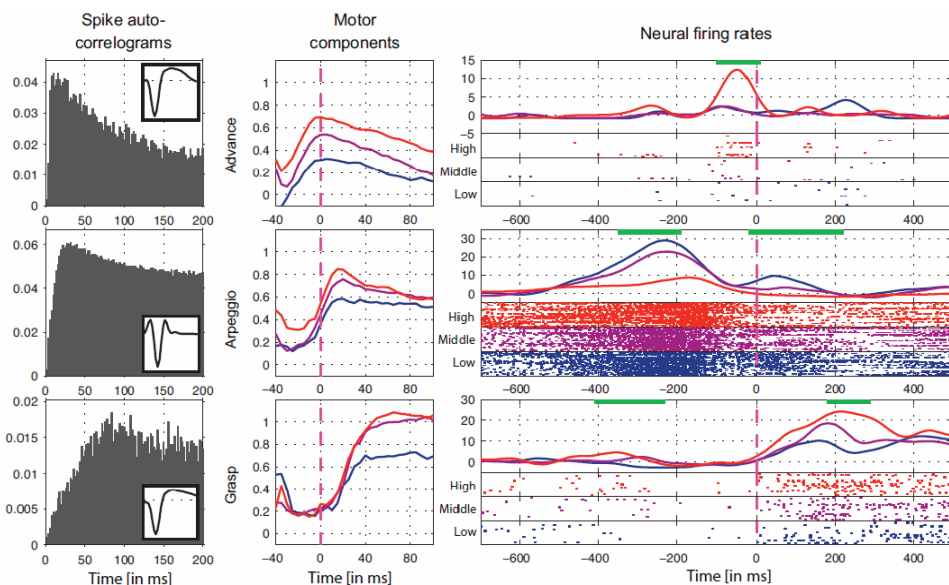

**Figure 4.** *Neuronal encoding of motor components.* Left column shows waveforms and autocorrelograms for each neuron. Middle column shows reach attempts sorted on the maximum value for its component during reaches. Red, purple and blue lines are equally sized groups of the maximal, intermediate and minimal executions of their corresponding component, respectively. Examples are shown for each component from top to bottom; Advance, Arpeggio and Grasp. Standardized peri-event firing rates and raster plots aligned to time point of maximum paw extension of individual trials for each group and averaged over all attempts in each group is shown in the rightmost column. Significant ( $p < 0.05$ ) difference in firing rates between any of the three groups is indicated by the green marks in the top of each plot.



## Study II

“On the Corticostriatal network during PD and levodopa-induced dyskinesia.”

### *Rationale*

The established role of the cortex's and basal ganglia's in motor aspects of both health and disease invites for studying it's involvement in Parkinson's disease and related disorders (de Carvalho et al., 2014). To this end, we implanted custom made electrode arrays targeting the primary motor cortex and connected regions of the dorsolateral striatum, we were interested in investigating the potential neurophysiological mechanisms related to the disorder. In the most widely used model (Cenci et al., 2002; Nadjar et al., 2009), rodents are unilaterally lesioned in the medial forebrain bundle with the neurotoxin 6-hydroxidopamine, eliminating large parts of the dopaminergic cell populations in the SNc and VTA that supply large parts of the forebrain with dopamine (Björklund and Dunnett, 2007).

### *Experimental layout*

After lesions, Parkinsonistic symptoms appeared gradually during a week, with animals showing motor impairments including asymmetric posture and gait as well as reduced dexterity in the forelimb contralateral to the lesion. Levodopa priming commenced one week after the lesion and the animals with dyskinetic symptoms upon levodopa challenge within one week were implanted with electrodes. Experiments begun one week after electrode implantation (Fig 5, top). Hemi-parkinsonistic rats were recorded for a 30 min baseline period, after which a moderately high dose of levodopa (and a peripheral DA-converting enzyme blocker) was injected intraperitoneally to elicit dyskinesia. The following period entails absorption of the drug to the circulatory system and distribution to peripheral tissues, after which the dopamine-precursor is taken up centrally to be converted to the active neurotransmitter dopamine, leading to a 10-20 minute delay from the injection before the rat displayed symptoms of dyskinesia. Symptoms of dyskinesia included abnormal involuntary orolingual, forelimb, and axial movements. In addition, as a consequence of the hemilesion, animals also display contraversive rotations. Although perhaps not translatable to the human, rotations have been shown to correlate well with the other types of uncontrolled movements, motivating their monitoring. Furthermore, the hemilesion approach has the benefit of allowing the non-lesioned hemisphere to be used as an internal control for direct comparisons within the animal, effectively reducing group sizes. For the group of animals receiving additional pharmacological interventions, injections at the time of peak dyskinesia were made directly to the cortical surface using a cannula placed adjacently to the electrodes in the primary motor cortex. This prevented the drug to enter the systemic circulation, which makes the contributions of individual structures to the eventual effects difficult to discern. For all groups of animals, the experiments continued until dyskinesia stopped (Fig 5, bottom).

## Experimental flow chart

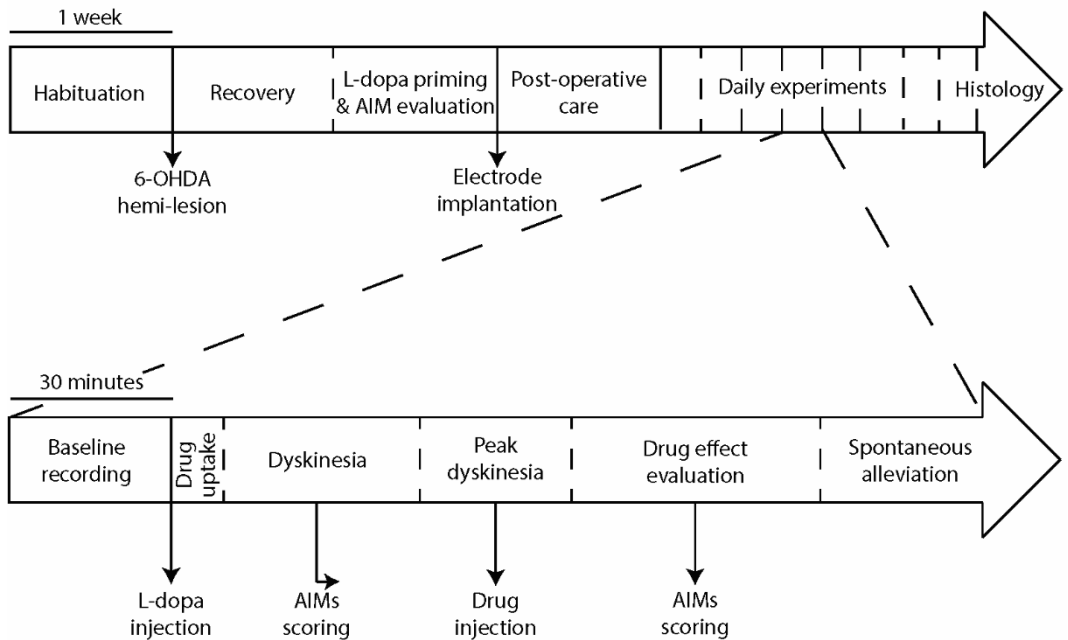

**Figure 5.** *Experimental flow-chart.* *Top:* animals were habituated for one week before MFB-hemileision and were one week later primed with levodopa for a week. Animals that were dyskinetic with a moderate dose of levodopa at 2 weeks post-lesion were implanted with electrodes. *Bottom:* Experiments included a 30 min baseline recording, after which a titrated dose of levodopa was injected to elicit dyskinesia. Upon uptake of the drug the animals became dyskinetic within ~15 minutes with intensity peaking at ~60 min. Abnormal involuntary movements were scored during the entire dyskinetic period. A drug was injected at 60 minutes for experiments involving pharmaceutical interventions and dyskinesia were evaluated until they ceased.

### *Local Field Potentials differences between hemispheres and states*

Measurements during the untreated baseline period revealed characteristic LFP traces from both cortex and the striatum from the lesioned hemisphere. Example of a cortical trace is shown in Figure 6 (black traces). When calculating the relative power of the LFP in different frequency bands during the baseline period, an increase in the spectral power below 30 Hz was detected, a hallmark for Parkinson's disease and inactive behavior (Hammond et al., 2007; Engel and Fries, 2010). When visually inspecting the traces, transient high-voltage spindles were found both during and outside of passive behavior, indicating these to be signatures of parkinsonism, corroborated by their absence after levodopa treatment. However, as the animals transitioned into the dyskinetic state, an even more noticeable change in the LFPs of the lesioned hemisphere

became evident (Fig 6, red traces). A strong, narrow-band oscillation around 80 Hz in the cortical electrodes appeared in relation to the dyskinetic symptoms and was co-expressed with these throughout the hourly long disease state. This was neither seen in the intact hemisphere of the same animals nor in non-dyskinetic animals treated with levodopa. Although at a much weaker power, this signal was also visible in the recording of the striatal electrodes during the dyskinetic state, perhaps expected considering the dense projections to striatum from the recorded areas of the cortex. The cortical oscillation was stable within and similar between recordings and animals (plateau value of fitted exponentials was  $80.9 \pm 2.7$  Hz) and resulted in an increased coupling strength within cortical electrodes in the frequency band ( $82.5 \pm 7.5$  Hz) during periods of dyskinesia. In addition to the LFP single units ( $n = 462$ ) were also recorded and analyzed in search for an explanation underlying the oscillatory phenomenon.

# Parkinsonistic

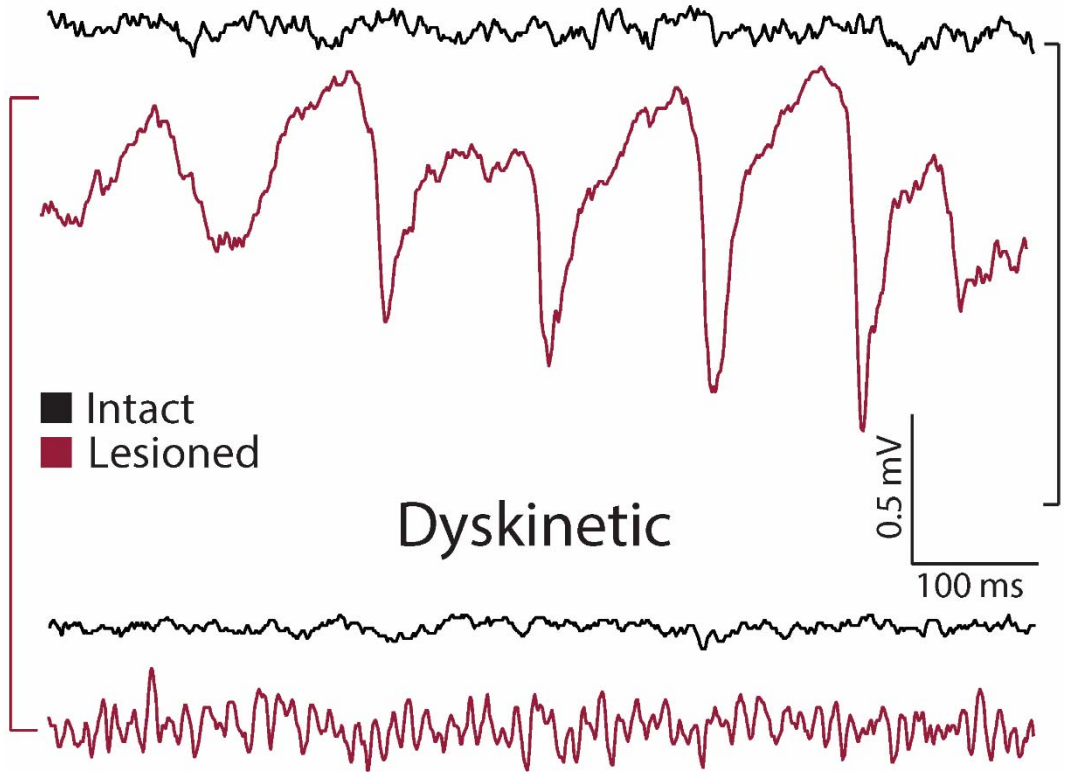

**Figure 6.** Raw LFPs from two states. Examples of traces from simultaneously recorded cortical field potentials in the intact (black) and lesioned (purple) hemispheres before (top) and after (bottom) levodopa administration.

## *Neuronal firing patterns in the oscillatory state*

Units were classified as pyramidal cells, medium spiny neurons and interneurons from cortex and striatum based on their spike-waveform shapes (Barthó et al., 2004). 72 % of the recorded units show firing pattern changes during dyskinesia compared to baseline, but firing rate was not considered causative for the resonant state since alterations were similar between hemispheres. Because of the distributed nature of neuronal patterning, emergence of rhythmic firing could still exist on a population level independent of firing rate changes. We therefore next looked for evidence of neuronal entrainments to the LFP's. Indeed, subgroups of similar size of both cortical and striatal principal cells and interneurons displayed entrainment to the 80 Hz signal, but with a fraction also entrained to lower frequencies during the baseline

conditions. Such cells with dual entrainment profiles were predominantly located in the cortex, suggesting that neurons in the lesioned motor cortex are prone to entrainment to the surrounding field in the dyskinetic rat.

#### *Local dopamine 1 receptor antagonism*

In search for explanatory cellular adaptations we found that tyrosine hydroxylase was markedly lower, but dopamine receptor 1 expression was unaltered in the lesioned hemisphere in both cortex and striatum, causing an imbalance between pre- and post-synaptic dopaminergic transmission. This was corroborated by an increase in immediate early gene expression upon levodopa challenge in the lesioned compared to the non-lesioned side. With post-synaptic D1Rs not being markedly different between sides, this opened up for the possibility that intracellular mechanisms downstream of the receptor, similar to striatal findings (Aubert et al., 2005), could be the reason behind the hyperexcitable network. To this end, we aimed to test whether D1R's were a necessary component in maintaining the oscillations by delivering an antagonist directly to the cortical surface. At the time of peak dyskinesia, within minutes after administration of the D1R selective antagonist (SCH 23390), the oscillation was repressed. Interestingly, a parallel suppression of dyskinesia also developed, alluding to dysregulated dopamine signaling in the cortex as a potential source for the malfunction in dyskinetic state.

#### *Homing in on the cause by zooming out on the circuit*

In search for a cause of the symptoms, pilot experiments targeting neurotransmitter systems were launched to perturb the cortical oscillations, with varying effects. Before launching additional drug experiments we realized that important questions about how parts of the circuit are physiologically involved in the pathogenic state would remain unsolved with only a neurohistochemical approach. To understand the functional relation between the behavior and the neural code, functional connectivity within and between relevant structures would have to be taken in to account. Therefore we first needed a way to attain a more comprehensive physiological view of the basal ganglia system

### Study III

“On the further development of large-scale electrophysiological recordings”

#### *Expanding the measures*

For this purpose we aimed to develop a new electrode for multi-structure parallel recordings in the rodent with several requirements taken into account. The size needed to be adapted for the rat skull but at the same time, a sufficient amount of recording channels and sites needed to be incorporated. Furthermore, the electrode should preferably be constructed as a single unit, to enable implantation in one single procedure. If each structure were to have a dedicated reference channel, which optimizes differential measurements, a system with 16 references would allow for 8 structures to be targeted in each hemisphere. A system with that amount of references was available together with 128 recording channels, which was deemed sufficient for our needs – giving an average of 9 channels per structure (8 recording & 1 reference). To be able to target different brain structures we aimed for a flexible system utilizing a 3D-printed aligner with high adaptability for positioning of the electrode wires (Fig 7). This had fixed spacing in 3 dimensions for each template, but allowed for convenient adaptation to other targets when wanted. For the electrically conducting parts we chose a modular design with a Kyocera connector soldered onto a custom printed circuit board template, connected to the recording device via a Kyocera-to-omnetics custom made adaptor. With such an electrode, we would be able to target most structures of the basal ganglia network (Str, STN, GP, SNr, Th,) together with at least two cortical areas, simultaneously. However, as these structures differ considerably in size; striatum stretching over large dorsoventral & mediolateral dimensions but STN occupying only around a cubic millimeter of space, the number of electrodes per site also was made adaptable. With a spacing of 250  $\mu\text{m}$  between electrode wires, the following setup was decided: 6 channels in the rostral forelimb area (a secondary cortical motor area with projections to the DMS), 8 channels in the primary motor cortex (with descending projections to e.g. DLS and spinal cord), 11 channels in dorsomedial and dorsolateral striatum, respectively, 12 channels in the globus pallidus, 9 channels in the ventroanterior/ventrolateral nuclei of thalamus, 6 channels in the subthalamic nucleus and 9 channels in the reticular part of substantia nigra. With this setup, we were suitably equipped to record from widespread areas to attain information on the functionality of the recorded structures during different states and behavior.

### Multielectrode Array Build Process

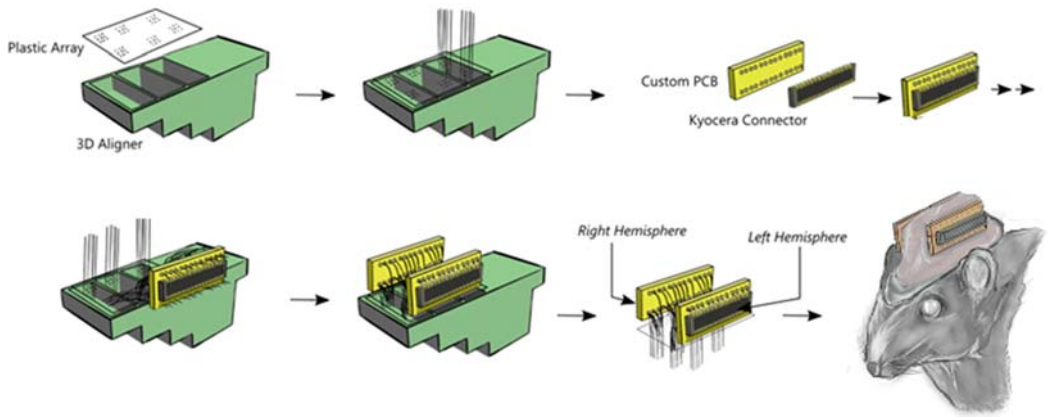

**Figure 7.** Overview of the MEA building process. A 2D perforated array is placed on a 3D aligner.  $33\mu\text{m}$  tungsten wires are placed into the holes in the plastic array to ensure the rightful positioning. Wires are secured to the plastic using ultraviolet light hardening adhesive. A Kyocera connector is attached to a custom built printed circuit board (PCB) using UV-adhesive and conductive epoxy. Wires are inserted through the PCB and secured on the medial side with adhesive. Wires are cut, deinsulated and attached with silver paint to the channels on the Kyocera/PCB piece. The entire electrode is secured and insulated with UV-adhesive and detached from the 3D aligner to be implanted in the rat brain. (Adapted from illustrations by Kumar, P, with permission)

## **Study IV**

“On the cortico-basal ganglia loop in levodopa-induced dyskinesia treatments”

### *Multi-structure recordings show unique activity patterns*

To gain insight into how neurophysiological activity patterns can be associated with disease states we utilized the novel electrode to do neuronal recordings from multiple structures of the cortico-basal ganglia-thalamic loop simultaneously. With the 6-OHDA hemilesioned rat we had a robust animal model offering multiple disease states with clear behavioral phenotypes. In the initial experiments, the previously discovered cortical oscillation was verified in dyskinetic animals and with the new comprehensive dataset we were now also able to confirm other electrophysiological hallmarks of the different disease states previously reported with the model – validating the feasibility of the technique. When inspecting the spectral contents of the LFPs over the course of an experiment, we noticed specific features in nearly all recorded structures for the different disease states before and after levodopa treatment. While our initial aim was to further investigate the oscillation and its relation to behavior, we now saw the opportunity to be able to differentiate between the distinct disease states based on their unique underlying neurophysiological activity patterns, including also less conspicuous changes in other brain structures. With such possibilities, we saw another potential application with the method – to evaluate the effects of drugs aimed for the treatment of the disease.

### *Recordings yield behaviorally relevant brain states*

Generally, and as in the case with the cortical oscillation in dyskinesia, disease relevant findings need to be described by a clearly defined alteration in relation to a control. For LFP recordings in a certain structure this often translates to a oscillation in clearly defined frequency bands upon presentation of symptoms (Staba and Bragin, 2011; Başar, 2013; Little and Brown, 2014). In the current recordings this would because of variability between structures and states include many different frequency bands, which would be very tedious to manually identify. To be of practical use, we therefor needed a more general method of describing the observed changes, optimally without disregarding any of the multivariate data that was acquired. The analysis was therefor done in the following manner: Unit activity was separate from LFP activity by bandpass filtering, where the LFP is the low frequent part. First, the locally measured field potentials were fourier transformed to generate frequency spectrograms over time with 8 second resolution. To eliminate background fluctuations and emphasize relevant frequency changes each such spectrum was then normalized to a spectral floor, which in brain recordings often is described well by a pink noise power law where the power for increasing frequencies follow a  $1/f^\alpha$  decline. This is necessary not least for higher frequencies, whose relative power otherwise are magnitudes smaller than for lower frequencies, in accordance with power laws for most physical



systems (Press, 1978). Signals from wire pairs from each structure were pooled, generating one average spectrogram per structure (see e.g. primary motor cortex in Fig 8). In these, hints of spectral differences between the three states could be seen in at least some of the structures per state.

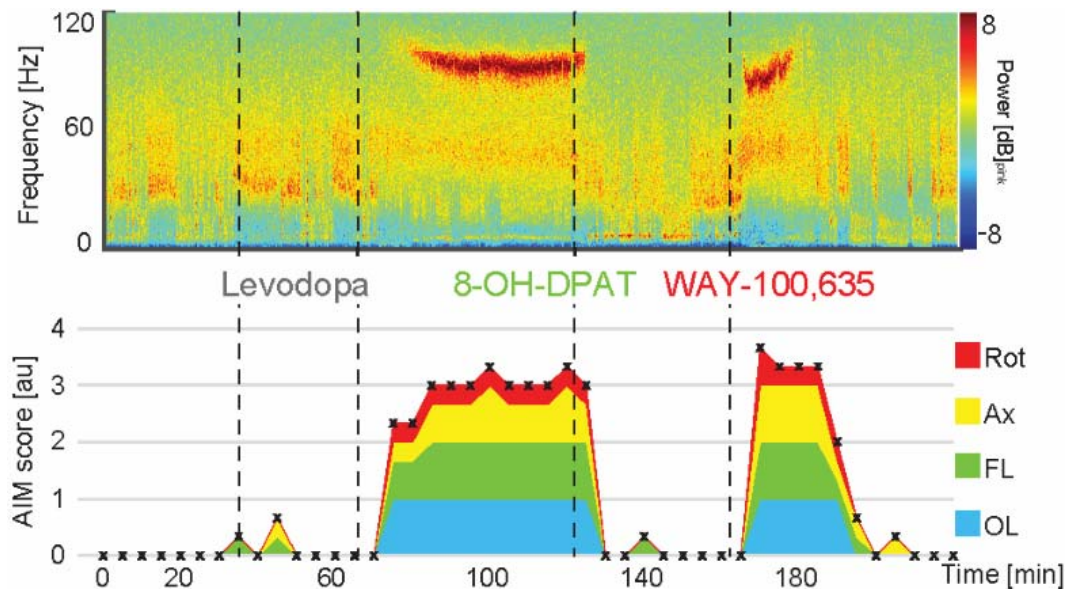

**Figure 8.** High frequency oscillations in the cortical local field potential is associated with dyskinesia. Top: Spectrogram from LFP's in the motor cortex of the lesioned hemisphere with a prominent 80 Hz oscillation in conjunction to the dyskinetic state (power spectrum normalized to pink-noise). A levodopa dose was administered (i.p.) at  $t \approx 60$  min. In this example, the 5HT1A (pre-synaptic serotonin receptor) agonist 8-OH-DPAT and its antagonist were administered at  $t \approx 120$  &  $t \approx 160$  min, respectively. Top right: Schematic view of the cortical surface illustrating recording positions of the cortical electrodes in relation to DLS and bregma. Bottom: AIMs score throughout the recording. Minimal amounts of dyskinesia before the levodopa administration at  $t \approx 60$  and after 8-OH-DPAT. (red: rotations, yellow: axial, green: forelimb, blue: orolingual).

### Visualizing the data

Subsequently, to get an intuitive representation of the states in two dimensions, the following steps were taken: For a behavioral state (defined by AIM score stability over time), the samples from the different structures were concatenated so that each 8 s sample was described by a unique vector, comprising the total of all spectral content (in 0.5 Hz bands from 0 to 200 Hz) in all structures at the time. All 8 s vectors per state and experiment were then normalized so that the mean and standard deviation for each state were equal to zero and one, respectively, in

effect homogenizing variability over states to ease comparability between them. To obtain a logical representation, a 2D coordinate system was created by letting the three different states constitute the reference points in the room. The spectral content of the pink noise normalized signals from all concatenated samples of averaged 8 s vectors from each structure in the control hemisphere (off levodopa) was set to Origo. The X-axis was defined as the difference between the signals from the parkinsonistic state (i.e. the baseline period in the lesioned hemisphere) and the simultaneously measured control state by subtraction of the mean of the control from the parkinsonistic mean in each structure. This difference was set to 1 and the distance of any sample from the control to the parkinsonistic cluster center thereby represents the degree of parkinsonistic-specific traits in the neuronal activity. With the x-axis as a reference point, the orthogonal difference vector between control and dyskinetic was then chosen as the equivalent projection for the y-axis. This difference vector between control and dyskinesia was then normalized in the same manner, so that a translocation along the axis from control towards the dyskinetic cluster would represent the degree of dyskinetic-specific traits (Fig 9A).

### *Application of the method*

At this point, we had possession of a tool that could relate the position of a new state cluster to the different disease states with respect to its effect on the neuronal signals, which we speculated would be used as a complementary evaluation of drug effects to standard behavioral assessments. At this point we were interested in delivering drugs to one of the disease states in order to validate the method. As the 6-OHDA lesion of the MFB creates a very severe reduction of dopaminergic cells in the SNc/VTA, therapeutic treatment with levodopa is not easily obtained due to the narrow therapeutic window. In this pilot study, we therefore chose to use drugs aimed for the treatment of the more easily attainable dyskinetic state.

### *Treatment effects*

Four treatments were used for the treatment of the dyskinetic state. Amantadine, Levetiracetam, Diazepam and 8-OH-DPAT, and doses with previously shown effects were chosen from the literature. Amantadine is a NMDA-receptor antagonist (Blanpied et al., 2005), clinically approved drug for the treatment of dyskinesia but with varying responses (Crosby et al., 2003). Levetiracetam is a clinically approved drug for the treatment of epilepsy, which has been clinically evaluated for their effects on LIDs (Wolz et al., 2010). Diazepam is a clinically approved benzodiazepine, that has been shown to have potential effects on levodopa-induced dyskinesia (Pourcher et al., 1989). 8-OH-DPAT is an experimental drug mainly working agonistically at the 5HT<sub>1A</sub> presynaptic autoreceptor (Larsson et al., 1990), reducing the release of 5-HT-localized dopamine (Carta et al., 2007). The experimental drug WAY-100,635, a 5HT<sub>1A</sub> receptor antagonist was used to block the effect of 8-OH-DPAT (Fornal et al., 1996).

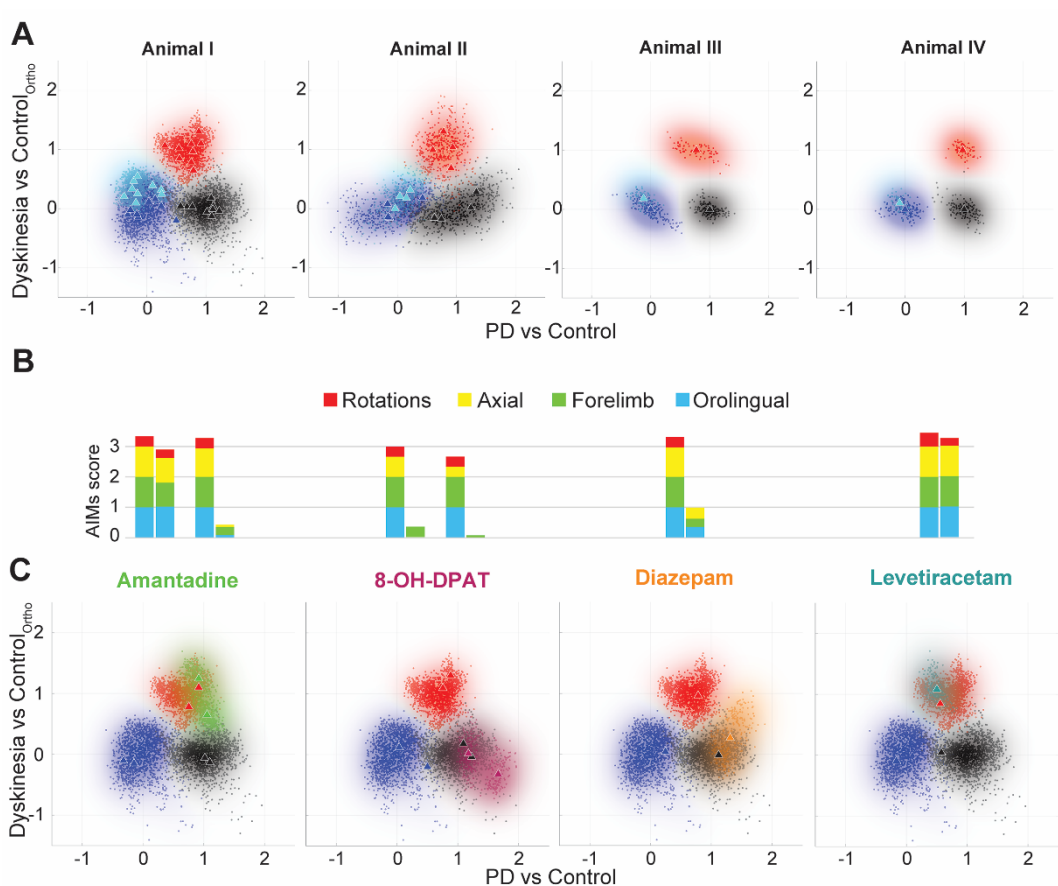

**Figure 9.** *Global state descriptions.* A: Systems level state descriptions based on LFP recordings from four rats (dark blue: control hemisphere during baseline, black: PD, red: dyskinesia, light blue: control hemisphere during dyskinesia). The x-axis equals the direction in spectral space with the largest difference between the control condition and the parkinsonian state. The Y-axis represents the largest difference between the control and dyskinetic state orthogonal to the X-axis. Small dots represents state coordinates during a recording (triangles are placed in the center of each experiment's cluster). B: AIM scores pre and post systemic treatment with four different drugs in the same rat. C: System level states induced by each of the drugs in the 2D-space, with axes defined by the main spectral differences [Control vs. PD] and [Control vs. Dyskinesia]<sub>Ortho</sub>.

### *Side effects*

Experiments were conducted in the same manner as before (Fig 3), and after having delivered drugs to have effects at the time of peak dyskinesia, behavioral assessment employing AIMs scoring was performed. Though some of the drug experiments showed clear reductions of the dyskinesia (Fig 9B), additional behavioral effects not captured solely by the AIM scale were also detected. The recorded neurophysiological signals in these experiments revealed a clear shift away from the dyskinetic state, corroborating the effect measure. However, as the dyskinesia were ameliorated, behavioral abnormalities were noted including recurring forepaw movements, drowsiness and abnormally flat body postures. When further analyzing the brain state induced by these drugs in relation to the control state, remaining differences between the treated state and the control condition were apparent (see e.g. Fig 9C). These differences, together with the observation that normal behavior was not restored by the treatments, suggest that the electrophysiological state description is able to capture additional aspects of the behavior that are not described with the unidimensional AIMs scale employed in this study.

### *Investigating informational content*

To clarify to what extent activity patterns in different frequency bands and brain structures contributed to the state descriptions we analyzed how well the drug-induced states could be separated using subsets of these. In the current dataset, we found that a higher number of brain structures generally improved classification performance, with a drastic increase for the early additions that reached asymptote at seven structures. When reducing the number of utilized frequency bands from all bands between 0-200 Hz to only include bands that have previously been reported to correlate with symptoms, the classification performance for the state separation decreased drastically. Using the best combination of the three bands; theta (3-9 Hz), beta (10-35 Hz) and gamma (65-100 Hz), surprisingly only gave a maximum classification performance of 35 %, compared to 96 % when using the full spectrum. Regardless of reason for the decline, we conclude that utilizing broad band multi-structure recordings is highly motivated in the current and presumably also in many other neurophysiological studies.



## **Discussion & Concluding remarks**



# Discussion and Concluding Remarks

The purpose of scientific enquiry is to generate knowledge of value for the community and the field of neurophysiology has good prospects to do so. By the combined study of normal and pathological states, knowledge that directs us towards an understanding of the neuronal principles of motor control can be attained, with potential implications for patients and healthy populations alike. Information about how the combined action of neuronal populations produce functions can be applied not only for remedies in diseases, but potentially also augment the existing repertoire of functions that we already possess (Wolbring et al., 2013; Fetz, 2015). How a specific motor output is selected from an endless pool of behaviors is one important question and what the functions of different synchronous neuronal activities are in various structures is another. The current thesis has apart from establishing new ways to address some of these questions also discovered previously unknown phenomena underlying malfunctions in pathological states, adding a targetable mechanism for future treatments of disease. A discussion of the findings follows below.

## *Choosing a relevant behavioral model*

Biomedical research intends to gain information about human physiology by the study of something sufficiently similar to the human to allow for translation of findings. For this, animal models are used that depending on the field of study can be differently closely related to the human. In studies of disease, overall face validity of a model is determined by phenotypic, construct and predictable similarity for its human equivalent (van der Staay et al., 2009). The disease model of Parkinson and dyskinesia used in this thesis is one of the few rodent models with high degree of correspondence for all subtypes of validity, which corroborates its translational potential. For practical applicability of a model however, valid biomarkers are equally important. In a recent review analyzing reasons for attrition rates in the drug industry, it was shown that for more than 80 % of the projects that made it through phase II trials had a translationally verified biomarker of efficacy, whereas for projects that were closed down less than 30 % did (Cook et al., 2014). Since the models employed in science are key for relevant predictions, validating them should be a top priority in research. By the results presented in this thesis the relationship between the rodent model of dyskinesia and the human have indeed been strengthened further, by the discovery of a new biomarker of the dyskinetic disease state that has now also been reported in the human (communication with Philip Starr laboratory).



In contrast to disease models, empirical knowledge about the validity of a model in normal physiology is hard to attain. Instead, great care is taken to match physiological readouts. In motor physiology, for example, the studied behavior is often chosen to bear resemblance to a human counterpart. The goal directed movement of reaching and grasping is an example of such, where the rodent displays great similarities to the corresponding human behavior (Klein et al., 2012). Apart from being multi-componential it is also goal-directed and highly repeatable, with controllable parameters including direction and distance. Variability in other parameters of importance for motor control such as speed and joint-angles makes this behavior a suitable substrate for elucidating important factors in actuation of movements. In addition, the weeklong period for learning of the task opens up for studies on the neural adaptations underlying improvement of motor actuation, e.g. by studying central representations of cutaneous receptive fields. Though learned behaviors sometimes can be challenging to draw conclusions from due to the inability to distinguish between a *de facto* faulty motor execution and a failure to recall the learned sequence (Berridge and Whishaw, 1992), this was deemed negligible in the setup since the behavior is not dependent on successions from discrete stages, but in similarity to normal behaviors can be adapted based on real time feedback.

#### *Benefits of detailed automatic tracking*

To be able to study minor differences between reaching trials and draw conclusions of the neural substrate of a multi-joint movement in a freely behaving animal, detailed monitoring of the movement is required. The commonest way of attaining such data is today by means of manual tracking. The limitations of this procedure are obvious; apart from being highly dependent on the skills of the operator, which will require hours of observation by well-trained observers manual scoring is also highly time consuming in itself. In our study, we have shown that high-resolution tracking can be reliably performed using automated techniques. The in-silico model in our study was matched to the recorded behavior with sub-millimeter precision and when correlated to the neuronal data, several cells with specific firing rate modulations relating to the actuation of previously suggested motor components of the reach and grasp movement were found. While this strengthens the proposed division of behavioral structure into the described subcomponents, other bases utilizing features like speed, direction or minute movements over individual joints can also be derived from the system and correlated to the recorded neuronal data. Nevertheless, these preliminary results clearly indicates the potential for the obtained kinematical description for neurophysiological studies of motor control.

#### *Lack of motor control and tissue adaptations*

In the case of the lost motor control in dyskinesia, a wide array of cellular correlates specific for the dyskinetic brain has been found. One example is that the degeneration of dopaminergic cells in SNc seen in patients has also been shown to be adjoined by a degeneration in VTA (Hirsch,

1994). Other findings include alterations in extracellular dopamine concentrations (Lindgren et al., 2010), post synaptic receptor expression (NMDAR: Fiorentini et al., 2006; DR<sub>1</sub>: Guigoni et al., 2007; AMPAR: Silverdale et al., 2010), dopamine receptor sensitization (Klawans et al., 1977; Gerfen, 2003), gene expression (Andersson et al., 1999) and plasticity (Picconi et al., 2003), recently summarized well by Cenci and Konradi, 2010. As important as these findings are, presenting convincing data and analyses related to different stages of the underlying pathology, information about the ongoing changes in conjunction with the expression of symptoms have the potential to offer a dynamic perspective to the one derived from post mortem tissue analysis.

### *Oscillations during the expression of symptoms*

By electrophysiological recordings in the dyskinetic animal during behavior we showed direct association of narrowband cortical gamma oscillations that were concurrent with the hours-long symptom expressions in the freely behaving animal. The significance of the cortical oscillation for the expression was further supported by the concurrent alleviation upon delivery of a DR<sub>1</sub>-antagonist directed to the cortical surface. In these experiments, intermittent dyskinesia were occasionally displayed by the animal, which were expectedly adjoined by the cortical oscillation. Though an underlying dopaminergic mechanism has been further strengthened by recent evidence (Dupre et al., 2016), the abruption of dyskinesia by the DA<sub>1</sub>-antagonist is not entirely conclusive, since arguably any agent reducing general neuronal excitability could cause similar depressive effects on the system. Nevertheless, the DR<sub>1</sub> antagonist was an intuitive choice of drug and considering that both initiation and disruption of symptoms is affected by dopaminergic signaling, this hypothesis remains compelling, even though awareness of other neurotransmitter systems' potential relevance is important. Thus, while the blockage of the cortical oscillation strengthened the correlation between the two phenomena, additional evidence as to what the cellular substrate for the oscillation is would also be desirable.

### *Neuronal correlates*

In search of the cellular substrate for the resonant LFP in cortex we analyzed the firing patterns of the hundreds of neurons that had been recorded. While the majority of cells in both cortex and striatum showed an altered firing rate during the dyskinetic state, this was not exclusive to the lesioned hemisphere. However, despite a lack of dissimilarities in firing rate between hemispheres, other underlying changes could still be present. When analyzing the temporal relationship between the LFP and the action potentials, a subgroup of cells in the lesioned hemisphere was found entrained to the 80 Hz oscillation in the dyskinetic state. In further analysis of cell entrainments to different frequency bands we noticed that several neurons were entrained to both the 80 Hz and the theta band (4-12 Hz) during the parkinsonistic state. When considering the relation of the two, it was only in the lesioned M1 that a majority of cells

displayed a transition in preferred entrainment frequency from low to high frequency in response to levodopa administration, a finding that was not detected in the neither striatum on the lesioned side nor on the non-lesioned side. As significant as these results may be, the question of how representative of the full system the recorded population of cells are remains, which led us to expand our recordings by doubling the amount of channels to 128. Concerns of potential tissue damage have been raised with using multiple recording probes but has formerly been shown to be manageable. In fact, the size of the glial scar as an indicator of tissue damage was in a recent study found to not be increased by multiple electrode implantations (Lind et al., 2012). To be able to add additional structures of the network to the recordings on the other hand, could be very beneficial.

### *Global cortico-basal ganglia recordings and representation of disease states*

Considering the distributed code and partially redundant activity of neurons within adjacent anatomical regions (Fetz, 1994), the expansion of electrodes to target widespread areas of the brain was done with the ambition to increase informational content. With the new electrode design we were able to relate the activity between all simultaneously recorded motor nuclei of the basal ganglia and motor cortices, opening up for a large variety of studies on dynamic changes between different states of activity in both health and disease. Comprehensive data on the collective actions of discrete sites from within a functional system could increase the ability to differentiate between states of disease and allow for better understanding of the pathophysiological processes. Direct information on the neurophysiological effects on a treatment is in this way attained from large parts of the brain, which expectedly gives a more representative view of system level responses to salient events and perturbations. From a practical standpoint, direct measures of neuronal signals also has the potential to reduce inherent issues with behavioral scoring, where the manual procedure of assessing an animals' behavior, as discussed above, is tedious and variable. While behavioral scoring optimally correlates strongly to such measures, especially from motor regions, it makes inferences about the underlying brain states indirectly, making differentiation between multiple brain-states more difficult to achieve.

### *Applicability of system's level brain states*

In experiments utilizing the novel electrodes in lesioned animals treated with levodopa, three different states were possible to study in the same experiment; control (from the non-lesioned hemisphere during baseline), parkinsonian (from the lesioned hemisphere at the same time) and dyskinetic (from the lesioned hemisphere after levodopa administration). At the same time, it would also be possible to determine in detail what the difference between the disease states and control in terms of their spectral content was. When inspecting the neuronal signals, distinct

activation patterns were found in individual structures both within and between these states. Apart from indicating that each structure had unique contributions in the different states, the dataset also alluded to that states could be discriminated neurophysiologically. Indeed, LFP signals from both the control, parkinsonistic and the dyskinetic state were significantly different to be able to reliably distinguish them from each other. This allowed the creation of a measure of severity of the disease based exclusively on the disease specific signals. Because of this, a measure of a drug's potential benefit could be derived from the creation of a chart representing these three states together with the state induced by the drug. Here we reasoned that the beneficial effects of drugs for the treatment of any of the disease states could be evaluated in the ability to abolish the disease specific signal and restore them to normal. A purely beneficial treatment would optimally produce a normalized state that would overlap with the control state in the representation.

Our data strengthened this hypothesis by showing that a treatment ameliorating dyskinesia without reinstating a normal behavior produces a cluster shifted away from the dyskinetic cluster that does not overlap with the control state. Unfortunately, this validation is only indirect. While it does hint at the system's resistance to false positives, to be conclusive the data need to explicitly show that an effective treatment actually produces a cluster overlapping with the control state. The conducted experiments were at the time neither big enough nor optimized to find the narrow dose interval for which the rodents were relieved of symptoms in either disease state without producing evident side effects. One reason for this is that the 6-OHDA MFB lesion produces a very terminal model with a minimal therapeutic window for the levodopa treatment. Since then, however, experiments have been conducted with positive treatment outcomes without apparent behavioral side-effects. Indeed, when plotted in the described 2D-representation, a clear overlap between the "normal" and the drug treated states is achieved, with clear separation from the pathological states (unpublished data). Though the dataset still is small, this provides compelling, more direct evidence that the initial hypothesis was correct.

One remaining question is if there is only "one" way for a given function of the brain to work properly by. If this is the case, seeking primarily to normalize the disease specific signals would be the desired aim with all treatments. If the system is more permissive, however, then additional outcomes in neuronal activities could also reproduce a quasi-healthy state. In any case, taking signals outside of the disease-defining range into account would be necessary to attain a truthful picture of the evaluated drug's neuronal effects. A related topic is that it presently is not known if a physiological signal in one structure has the same consequence in another. Will, for example, an aberrant signal appearing in motor areas with concomitant motor symptoms equate to symptoms pertaining to another area's respective function if present there? While this is plausible considering the similarities in pathogenic signals in different diseases, further studies will be needed to answer this more definitely.

### *Possible improvements of the state description method*

In the publication we chose to plot the differences between the control condition and the two disease states, with the parkinsonian state on the x-axis and the dyskinetic on the y-axis (Fig 8A & C). To de-correlate the states, the y-axis was chosen to be orthogonal to the x-axis. A consequence of this is that certain changes along the original dyskinetic axis risked not resulting in a change in the y-coordinate. For this reason, letting the axis of the state that a treatment is directed towards be the primary base from which the other state is orthogonally defined would nuance the data in another, potentially more intuitive way. In reality, measures are often varied before a representation is selected for display.

It should be noted that the axis of disease in the study is defined by the signals patterns that vary the most between a state of disease and control. Changes in these particular signals will thus have the strongest influence on the position of a new cluster, even though alterations outside of this range could be affected by a drug. Therefore, if a drug were to induce another potentially pathological state, via effects on signal patterns other than those defining the disease axis, this risks being underestimated. This problem is similar to that of the behavioral scoring, where measurement only of the symptoms of disease might risk losing valuable information on other effects of a drug. To account for this, inducing additional states by reference drugs so that more meaningful dimensions are added would help complementing the information derived from the neuronal space.

The real benefit of being able to represent neurophysiological data in the proposed way is that drugs are evaluated not only in their ability to ameliorate disease specific signals, but also considers the ability to reproduce “healthy” signals. This second factor is especially important since effects of any drug in addition to its ability to treat disease-specific signs are very hard to predict. Although qualitative behavioral assessments on the “degree of normality” are frequently reported, attaining quantitative and comparable measures of this would be complicated because of the multitudes of potential behavioral repertoires that exist.

### *Future applications*

Considering the highly distributed functionality within the brain and that many structures are involved in multiple behaviors, deciphering relevant differences will require elaborate experimenting. Objective recordings characterizing these in many species, including the human, would be an initial goal to get to an understanding of the comparative biology between species. Such knowledge could be used to validate many currently employed models of disease and increase their translational power to the human in different diseases. Applying this technique to other models of disease has the potential of opening up novel ways of characterizing drug effects aimed for the treatment of CNS-disorders. While electrophysiological readouts from motor regions are indeed highly correlated with motor

behavior, many diseases do not produce overt behavioral alterations, making them difficult to study. This is demonstrated by the lack of translatability of many of the preclinical animal models in this area, which in turn has impeded drug development for diseases such as persistent pain states, psychosis and depression (Nestler and Hyman, 2010; Cook et al., 2014). Similar to motor systems, electrophysiological readouts from other regions have the potential to measure the functions pertained to those respective areas. Applying this technique with such recordings therefore has the potential of opening up novel ways of characterizing drug effects aimed for the treatment of these diseases.

### *Merging data in dyskinesia*

In drawing conclusions on a broader level, the information gained by in vitro techniques offers insights: In the in slice preparations, Picconi et al. (2003) showed that a dyskinetic group of animals, but not a non-dyskinetic levodopa treated control group, lacked the fundamental ability to depotentiate cortical stimuli after a prior potentiation. Because activation of both the DR<sub>1</sub> and downstream targets effectively blocked the otherwise functional depression, the effect was suggested to be mediated by dopamine's interaction with the DR<sub>1</sub>. The implication of this loss of bidirectional plasticity in striatal projection neurons is that excitatory input to striatum during a dopaminergic tone can only be strengthened, since their ability to depotentiate inputs has been lost. Having dense projections to the same set of striatal cells, the malfunction of the cortex in cohort with the cell-physiological alterations in striatum could offer a more holistic account for the development of dyskinesia: if in the motor cortical end an aberrant signal is continuously disturbing the output while in the striatal end cortical inputs are emphasized, this could explain how the disrupted signaling process leading to symptoms emerge.

How this ties to the thalamostriatal input to the same subsets of cells has not been established, but it is noteworthy that the glutamatergic outputs from cortex and thalamus to a large extent have histochemically distinct profiles (Smith et al., 2004). Corticofugal fibers primarily associate with the vesicular glutamate transporter vGlut1 and thalamofugal fibers with the vGlut2 (Kaneko and Fujiyama, 2002). In the afferent inputs to thalamus, a functional dichotomization between these two sets has been suggested by Sherman and Guillery (2011), with vGlut1 expressing fibers having a modulatory while vGlut2 have a driving role in information transmission. The drivers have strong and predictable effects on the receiver cells while the modulators affect information transmission by subtle tuning of spike probabilities. If this 'driver and modulator' division of glutamatergic communication also applies to non-sensor systems is under current debate (Varela, 2014), but raises the question if thalamus might be more influential in the normal- and pathophysiology of the basal ganglia than previously appreciated. With vast outputs to other nuclei both within and outside the basal ganglia (Féger et al., 1994; Marini et al., 1999) and its degeneration in e.g. parkinsons disease (Henderson et al., 2000), further studies unraveling thalamus' role in motor functions are highly anticipated.

### *General concluding remarks*

The nervous system works in mysterious ways but many anatomical regions have been shown to have high informational redundancy and high informational specificity through different behaviors and states. When studying the difference that makes a difference in any context, the initial challenge is thus to isolate and define the differences of interest. To get towards understanding of a complex system such as the brain we are guided by increasingly detailed descriptions that with methodological developments can be answered with increasingly detailed data, generating knowledge that allows for new testable hypotheses and refined definitions. With well-designed studies utilizing techniques ranging from in vitro to in vivo, behavioral and electrophysiological recordings, in healthy and diseased states, information will be gained that will advance the field in the direction of a more complete representation of the system.

The physiological signals discussed in this thesis are analyzed and discussed from a motor system perspective, which imparts the bias that brain functions relate only to physical enactments of sorts. It should not be forgotten that other functions such as motivational states, emotions, internal representations of external space and perhaps even time are also built in to the same circuits. However, the difficulty to estimate such internal states makes motor output the most commonly measured event in neurophysiological experiments with living animals, almost regardless of the scientific question, which can be hard to reconcile considering the distinct feeling of subjective value that non-motor functions have to us. It is of course possible that these in any case are rightfully considered as mere predecessors of the only thing that can make a physical difference in the world; an event in external space.

After all, it was such entelechy that made something of nothing in the first place.

# Acknowledgements

*Per Petersson* – Putting the super into supervisor as a mentor, a *polymath* and the group Nestor. You are a great inspiration not only scientifically, by showing that anything is doable with due effort and that all findings can be viewed in positive light, but also personally by showing endless tolerance and kindness towards everyone. The unconditional trust you show people within and outside work is clear evidence of a pure mind. In my first year of studies when bugging you with all kinds of newbie-questions, I remember you always taking the time to turn around and answering them thoroughly with delight. I later came to know that you were writing a massive ERC grant proposal at the time, and have since then thought that the fact I didn't come to know until afterwards summarize things well. I've learned a lot throughout the years (perhaps because they've become so many ☺) and whatever the future holds, you'll remain a milestone in my professional and personal development.

*Ulrike Richter* – Having had the pleasure to work with you with both science, teaching and administration for years now, I regard us as great examples of that different personalities can truly add to each other (at least unilaterally ☺). You have probably been the one that have complemented me the most in our group, with your relentless systematicity and feel for detail that others sometimes have a less *coherent* view on. I'm also forever grateful for your introduction of Sidney Bechet in times of despair – he's still a favorite! Together with the most contaminating outbursts of laughter you occasionally respond with makes me *liebe dein stil!*

*Pär Halje* – I still remember looking through your strange curriculum, with a background in the hard physics field and a Ph.D. in the fuzzy consciousness field with matlab denoted as a fluently spoken language. I don't know the translation of *Skalman*, but since you early on made me realize the importance of creating new definitions (with words as the example) I'm inventing Shelly and assigning it to you! Not only have we had good times at work, but we've also shared dim nights with discussions worth remembering - but do we? Let's say dat we do... ☺

*Joel Sjöbom* – The newest candidate of the group and boy what a recruit. Already from the beginning it was apparent that you have the potential for success in the field with a positive attitude, a generous personality and a problem-solving mindset driven by curiosity. As your table-neighbor we have been through multiple discussions on human and animal grooming habits, often mid-pointing in some crazy time and *Rum* association, but mostly ending up in something that makes more sense than before. Just keep doing what you do and you'll be more than fine!



*Nedjeljka Ivica* – I remember the first happy days after your arrival to Lund, when we were sitting in the lab going through the cheetah system and I was trying to explain all the crazy signals we were recording. That was then and this is now, and today I've probably learned more from you than you from me, which I'm ever grateful for. *Živjeli!*

*Ivani Brys* – After having met you the first time in Brazil, where you introduced me to your friends and showed me around, I understood that the warm weather had influenced your heart temperature - regardless of how *statistically* improbable it sounds (I'm a specialist at extrapolating under-sampled data you know ☺)! With the determination you've shown here, I'm certain the warmth will return in your post-post-doc life, even if it won't be equatorial.

*Mohsin Mohammed* – We started as colleagues in the same boat many years ago and we ended up as friends immediately. I'll never forget our talks ranging from goofy to scientific to spiritual, that have made impressions for life. Not to mention when you and your lovely family showed me the beauty of India (from the back of a MC)! We had childish fun for a year or two and then we were blessed with wonderful women that aimed to make men out of us (work in progress ☺). Now we're all on the verge of starting a new chapter of grown up fun instead (with children that is) and many moments are to come. Keep up the good *spirit!*

*Lina Gällentoft* – As one of the original companions you have always had a special spot in my core. Your calm being always makes it feel safe to talk with you about anything and boy have we been through topics (ranging from wet nights on car hoods & shotguns to betablockers & Tolstoy ☺). As one of the most independent neurobiology-candidates out there I'm sure your upcoming thesis will win a somekind of prize to which you will act like whatevva, while silently thinking *yay*.

*Bengt Ljungqvist* – The undisputed *yogi* of NRC and one of the few that have been doing this for longer than me. I'm dedicating my next lotus to you for all the stray discussions we've had throughout the years.

*Gustav Lind* – How are you doing up there Gustav? In Eslöv, of course... After some months of me adapting to the accelerating impact that gravity have on words from high *altitudes*, I came to see that your understanding of physiology (and berries and what not) was something out of the ordinary. The patients of Eslöv are lucky to have a physician like you!

*Johan Agorelius* – Aggo! Few people have had as many serious *DUI's*\* as the two of us, who share as many moral viewpoints as we don't. It is just recently I've come to realize that the superman theory all makes sense - Clark Kent is a perfect example ☺ We're the yin to eachother's yang and I love to hate it so let's continue the journey! \*Discussions Under the Influence

*Per Köhler* – Twitter’s own pub med-ninja, whose chirps I follow tenaciously. *Educated* in the strangest of subjects and more generous with crazy case-reports than anyone alive. The guy with 5 inch nails hidden partially under a hat but mostly in his brain is a personal favorite.

*Petter Pettersson* – One of the most well-intending people around and with the coolest wardrobe at NRC! Having shared multiple day and nights with intense discussions spanning the entire emotional spectra I’ve learned that your passion for righteousness is only oversized by your big... heart ☺.

*Jens Schouenborg* – The talks we’ve had have been good and I’m happy there’s been time for them at all considering how much you have on your table, figuratively speaking (although literally it was packed with tons of articles at my first interview). It would be fun to discuss some science when you get time for *physiology* again, since my professor in Boston looked slightly star-struck when I told him you were my co-PI!

*Martin Garwicz* – The cool professor who I admire for more than just being a namesake (the given name that is, the surname I’m still not sure of ☺). Speaker of at least 4 languages and a logical mind with just that philosophical touch that’s needed to inspire youngsters in development – I’ll try to keep your *memes* alive!

*Claudia Lopes* – You were never in Lund but since you mentioned me in your HMS-thesis I owe you this ☺! On a more serious note, having been one of the first researchers I had the pleasure of working with you were one of the reasons I got into science in the first place, with you and Fu-Chia setting good examples for the noob that arrived to Boston. Still being a great friend, just a phone call away, I reckon we’ll be long lasting pals regardless of transatlantic time differences (but convincing your hubby-2-be to move back to *Europe* would certainly help!).

*Fam. Luani* – Not only because of the joyful times and culinary foods we’ve shared, but also because of shared experiences from before our acquaintance, you are a family to take *inspiration* from. Professionally and philosophically you are great examples of how destiny and happiness is shaped by perseverance towards clear goals and open mindsets. May the dielli shkelqu pà er!

*Kushtrim Regjepaj* – Behind every great construction is a great *architect*, and as much as I would like to claim the title myself, the neurochitect of this thesis has indisputably been you. Your unique ability to translate fuzzy thoughts, scribbles and words to crystal-clear figures and scientific illustrations has helped not only me, but the entire lab in our aims to share knowledge.

*The Regjepaj sisters (motrat Regjepaj)* – To have the luxury to come to a *warm* home, a *hot* meal and radiating *hearts* after a long day at work is what has been the true physiological basis for this thesis. Without sisters like a Zykë, a Tolë and a Lenë upholding the most important but most unrecognized things of all – the everyday machinery – this thesis would not even have been possible.

*Vlora Tamtè* (née Regjepaj) – My love, my anchor and my better half - Let's make the end of this book the beginning of our new chapter. U takuam heren e par para se kemi fillu rrugen e shkollimit, e me te vertete jemi bashzhvillu gjat kesaj kohe. *Ti je e vetmja* qe ke perjetu ket udhetim prej fillimi deri mbarimi, ne fund te cillit kemi dal ma te fort te dyt. Pa ty nuk kisha duru e pa ty s'un duroj.

*My Family* – Mom, Dad, Brother, Sister, Monica, Jennie, Michael and all adorable children. Always showing limitless support and interest throughout the years of studies, you are included in the core of this thesis. It is your endless love that has shaped me to who I am today, and you will all hopefully continue doing so for long.

*Agneta SM* – Ruler of rulers and rules!

*Alex H* – Breaking bad trends in NRC!

*Ali G* – Alle, Olé!

*Anders J* – Treats signals as well as people!

*Andrea N* – The irreplaceable spider in the hub (with or without hubby)!

*Angela C* – Regina di LIDs!

*Cissi L* – Screw Cancer (and maybe some snygg Stockholmare too 😊)!

*Funding agencies* – Much obliged!

*Joakim E* – Creator of triple consciousness'!

*Jonas T* – A pure White Truffle Sauce-guy, way better than brown gravy!

*Judith B* – Ein kleines Mädchen with more than just artificial intelligence!

*Julia B* – Gotlands Shakespeare!

*Lasse C* – Eternal master of construction!

*Leila E* – Selam, koridori & khodafes!

*Lina P* – Awesomeness reincarnate!

*Linda E* – Queen of fun(ds)!

*Lucas K* – West coast = Best coast!

*Opponents* – Thanks for the effort!

*Marcus G* – Pedagogical neurojazzdrummer #1!

*Mengliang Z* – Ruidiǎn > Dānmài, but Zhōngguó?!

*Niclas L* – Late night lab-philosopher!

*Nisse D* – From erector spinae to rektor parvus!

*Palmi P* – Satt íslendingur vísindamaður!

*Peter P* – Kattarp→Lund, < 30 min (⊕)!

*Pomesh K* – A new med with a sharp head!

*Suz R* – The grandmother any neuroscientists wishes for!

*Tobias P* – Grötviks brainiest and brawniest volleybolling scientist!

*Övriga* – Thanks for making the world habitable!



# References

- Albin RL, Young AB, Penney JB.** The functional anatomy of basal ganglia disorders. *Trends Neurosci* 12: 366–75, 1989.
- Aldridge JW, Berridge KC.** Coding of serial order by neostriatal neurons: a “natural action” approach to movement sequence. *J Neurosci* 18: 2777–87, 1998.
- Alexander GE, DeLong MR, Strick PL.** Parallel organization of functionally segregated circuits linking basal ganglia and cortex. *Annu Rev Neurosci* 9: 357–81, 1986.
- Alexander GE, DeLong MR.** Microstimulation of the primate neostriatum. I. Physiological properties of striatal microexcitable zones. *J Neurophysiol* 53: 1401–16, 1985a.
- Alexander GE, DeLong MR.** Microstimulation of the primate neostriatum. II. Somatotopic organization of striatal microexcitable zones and their relation to neuronal response properties. *J Neurophysiol* 53: 1417–30, 1985b.
- Alonso-Frech F, Zamarbide I, Alegre M, Rodríguez-Oroz MC, Guridi J, Manrique M, Valencia M, Artieda J, Obeso JA.** Slow oscillatory activity and levodopa-induced dyskinesias in Parkinson’s disease. *Brain* 129: 1748–57, 2006.
- Andersson M, Hilbertson A, Cenci MA.** Striatal fosB expression is causally linked with l-DOPA-induced abnormal involuntary movements and the associated upregulation of striatal prodynorphin mRNA in a rat model of Parkinson’s disease. *Neurobiol Dis* 6: 461–74, 1999.
- André VM, Cepeda C, Fisher YE, Huynh M, Bardakjian N, Singh S, Yang XW, Levine MS.** Differential electrophysiological changes in striatal output neurons in Huntington’s disease. *J Neurosci* 31: 1170–82, 2011.
- Aosaki T, Graybiel AM, Kimura M.** Effect of the nigrostriatal dopamine system on acquired neural responses in the striatum of behaving monkeys. *Science* 265: 412–5, 1994.
- Aubert I, Guigoni C, Håkansson K, Li Q, Dovero S, Barthe N, Bioulac BH, Gross CE, Fisone G, Bloch B, Bezard E.** Increased D1 dopamine receptor signaling in levodopa-induced dyskinesia. *Ann Neurol* 57: 17–26, 2005.
- Bar-Gad I, Morris G, Bergman H.** Information processing, dimensionality reduction and reinforcement learning in the basal ganglia. *Prog Neurobiol* 71: 439–473, 2003.
- Barnes TD, Mao J-B, Hu D, Kubota Y, Dreyer AA, Stamoulis C, Brown EN, Graybiel AM.** Advance cueing produces enhanced action-boundary patterns of spike activity in the sensorimotor

striatum. *J Neurophysiol* 105: 1861–78, 2011.

**Baron MS, Vitek JL, Bakay RA, Green J, Kaneoke Y, Hashimoto T, Turner RS, Woodard JL, Cole SA, McDonald WM, DeLong MR.** Treatment of advanced Parkinson's disease by posterior GPi pallidotomy: 1-year results of a pilot study. *Ann Neurol* 40: 355–66, 1996.

**Barthó P, Hirase H, Monconduit L, Zugaro M, Harris KD, Buzsáki G.** Characterization of neocortical principal cells and interneurons by network interactions and extracellular features. *J Neurophysiol* 92: 600–8, 2004.

**Başar E.** Brain oscillations in neuropsychiatric disease. *Dialogues Clin Neurosci* 15: 291–300, 2013.

**Baumann CR.** Epidemiology, diagnosis and differential diagnosis in Parkinson's disease tremor. *Parkinsonism Relat Disord* 18 Suppl 1: S90–2, 2012.

**Benabid AL, Pollak P, Louveau A, Henry S, de Rougemont J.** Combined (thalamotomy and stimulation) stereotactic surgery of the VIM thalamic nucleus for bilateral Parkinson disease. *Appl Neurophysiol* 50: 344–6, 1987.

**Berke JD, Okatan M, Skurski J, Eichenbaum HB.** Oscillatory entrainment of striatal neurons in freely moving rats. *Neuron* 43: 883–96, 2004.

**Berke JD.** Functional properties of striatal fast-spiking interneurons. *Front Syst Neurosci* 5: 45, 2011.

**Berretta S, Parthasarathy HB, Graybiel AM.** Local release of GABAergic inhibition in the motor cortex induces immediate-early gene expression in indirect pathway neurons of the striatum. *J Neurosci* 17: 4752–63, 1997.

**Berridge KC, Whishaw IQ.** Cortex, striatum and cerebellum: control of serial order in a grooming sequence. *Exp brain Res* 90: 275–90, 1992.

**Bertolini A, Ferrari A, Ottani A, Guerzoni S, Tacchi R, Leone S.** Paracetamol: new vistas of an old drug. *CNS Drug Rev* 12: 250–75, 2006.

**Bjursten LM, Norrsell K, Norrsell U.** Behavioural repertory of cats without cerebral cortex from infancy. *Exp brain Res* 25: 115–30, 1976.

**Björklund A, Dunnett SB.** Dopamine neuron systems in the brain: an update. *Trends Neurosci* 30: 194–202, 2007.

**Blanpied TA, Clarke RJ, Johnson JW.** Amantadine inhibits NMDA receptors by accelerating channel closure during channel block. *J Neurosci* 25: 3312–22, 2005.

**Bliss T V, Lomo T.** Long-lasting potentiation of synaptic transmission in the dentate area of the

anaesthetized rabbit following stimulation of the perforant path. *J Physiol* 232: 331–56, 1973.

**Bolam JP.** *Microcircuits, molecules and motivated behavior: microcircuits in the striatum.* MIT Press, 2004.

**Breger LS, Dunnett SB, Lane EL.** Comparison of rating scales used to evaluate L-DOPA-induced dyskinesia in the 6-OHDA lesioned rat. *Neurobiol Dis* 50: 142–50, 2013.

**Briggs F, Mangun GR, Usrey WM.** Attention enhances synaptic efficacy and the signal-to-noise ratio in neural circuits. *Nature* 499: 476–80, 2013.

**Brodmann K.** *Vergleichende Lokalisationslehre der Großhirnrinde in ihren Prinzipien dargestellt auf Grund des Zellenbaues.* Leipzig: Barth, 1909.

**Brown P, Oliviero A, Mazzone P, Insola A, Tonali P, Di Lazzaro V.** Dopamine dependency of oscillations between subthalamic nucleus and pallidum in Parkinson's disease. *J Neurosci* 21: 1033–8, 2001.

**Brown P.** Oscillatory nature of human basal ganglia activity: relationship to the pathophysiology of Parkinson's disease. *Mov Disord* 18: 357–63, 2003.

**Buszaki G.** *Rhythms of the brain.* New York. Oxford University Press, 2006.

**Buzsáki G.** Cognitive neuroscience: Time, space and memory. *Nature* 497: 568–9, 2013.

**Calabresi P, Gubellini P, Centonze D, Picconi B, Bernardi G, Chergui K, Svenningsson P, Fienberg AA, Greengard P.** Dopamine and cAMP-regulated phosphoprotein 32 kDa controls both striatal long-term depression and long-term potentiation, opposing forms of synaptic plasticity. *J Neurosci* 20: 8443–51, 2000.

**Calabresi P, Mercuri NB, Stefani A, Bernardi G.** Synaptic and intrinsic control of membrane excitability of neostriatal neurons. I. An in vivo analysis. *J Neurophysiol* 63: 651–62, 1990.

**Calabresi P, Picconi B, Tozzi A, Ghiglieri V, Di Filippo M.** Direct and indirect pathways of basal ganglia: a critical reappraisal. *Nat Neurosci* 17: 1022–30, 2014.

**Carlsson A, Lindqvist M, Magnusson T.** 3,4-Dihydroxyphenylalanine and 5-hydroxytryptophan as reserpine antagonists. *Nature* 180: 1200, 1957.

**Carpenter MB, Whittier JR, Mettler FA.** Analysis of choreoid hyperkinesia in the Rhesus monkey; surgical and pharmacological analysis of hyperkinesia resulting from lesions in the subthalamic nucleus of Luys. *J Comp Neurol* 92: 293–331, 1950.

**Carta M, Carlsson T, Kirik D, Björklund A.** Dopamine released from 5-HT terminals is the cause of L-DOPA-induced dyskinesia in parkinsonian rats. *Brain* 130: 1819–33, 2007.



**Carta M, Lindgren HS, Lundblad M, Stancampiano R, Fadda F, Cenci MA.** Role of striatal L-DOPA in the production of dyskinesia in 6-hydroxydopamine lesioned rats. *J Neurochem* 96: 1718–27, 2006.

**de Carvalho M, Eisen A, Krieger C, Swash M.** Motoneuron firing in amyotrophic lateral sclerosis (ALS). *Front Hum Neurosci* 8: 719, 2014.

**Cenci MA, Konradi C.** Maladaptive striatal plasticity in L-DOPA-induced dyskinesia. *Prog Brain Res* 183: 209–33, 2010.

**Cenci MA, Lundblad M.** Ratings of L-DOPA-induced dyskinesia in the unilateral 6-OHDA lesion model of Parkinson's disease in rats and mice. *Curr Protoc Neurosci* Chapter 9: Unit 9.25, 2007.

**Cenci MA, Whishaw IQ, Schallert T.** Animal models of neurological deficits: how relevant is the rat? *Nat Rev Neurosci* 3: 574–9, 2002.

**Cerminara NL, Apps R.** Behavioural significance of cerebellar modules. *Cerebellum* 10: 484–94, 2011.

**Chen JJ.** Anxiety, depression, and psychosis in Parkinson's disease: unmet needs and treatment challenges. *Neurol Clin* 22: S63–90, 2004.

**Chevalier G, Deniau JM.** Disinhibition as a basic process in the expression of striatal functions. *Trends Neurosci* 13: 277–80, 1990.

**Chiken S, Shashidharan P, Nambu A.** Cortically Evoked Long-Lasting Inhibition of Pallidal Neurons in a Transgenic Mouse Model of Dystonia. *J Neurosci* 28: 13967–13977, 2008.

**Churchland MM, Cunningham JP, Kaufman MT, Foster JD, Nuyujukian P, Ryu SI, Shenoy K V.** Neural population dynamics during reaching. *Nature* 487: 51–6, 2012.

**Cook D, Brown D, Alexander R, March R, Morgan P, Satterthwaite G, Pangalos MN.** Lessons learned from the fate of AstraZeneca's drug pipeline: a five-dimensional framework. *Nat Rev Drug Discov* 13: 419–31, 2014.

**Costa RM, Lin S-C, Sotnikova TD, Cyr M, Gainetdinov RR, Caron MG, Nicolelis MAL.** Rapid alterations in corticostriatal ensemble coordination during acute dopamine-dependent motor dysfunction. *Neuron* 52: 359–69, 2006.

**Craig AD.** How do you feel? Interoception: the sense of the physiological condition of the body. *Nat Rev Neurosci* 3: 655–66, 2002.

**Cromwell HC, Berridge KC.** Implementation of action sequences by a neostriatal site: a lesion mapping study of grooming syntax. *J Neurosci* 16: 3444–58, 1996.

**Crosby NJ, Deane KHO, Clarke CE.** Amantadine for dyskinesia in Parkinson's disease. *Cochrane database Syst Rev* : CD003467, 2003.

**Cui G, Jun SB, Jin X, Pham MD, Vogel SS, Lovinger DM, Costa RM.** Concurrent activation of striatal direct and indirect pathways during action initiation. *Nature* 494: 238–42, 2013.

**d'Avella A, Pai DK.** Modularity for sensorimotor control: evidence and a new prediction. *J Mot Behav* 42: 361–9, 2010.

**DeFelipe J, López-Cruz PL, Benavides-Piccione R, Bielza C, Larrañaga P, Anderson S, Burkhalter A, Cauli B, Fairén A, Feldmeyer D, Fishell G, Fitzpatrick D, Freund TF, González-Burgos G, Hestrin S, Hill S, Hof PR, Huang J, Jones EG, Kawaguchi Y, Kisvárdy Z, Kubota Y, Lewis DA, Marín O, Markram H, McBain CJ, Meyer HS, Monyer H, Nelson SB, Rockland K, Rossier J, Rubenstein JLR, Rudy B, Scanziani M, Shepherd GM, Sherwood CC, Staiger JF, Tamás G, Thomson A, Wang Y, Yuste R, Ascoli GA.** New insights into the classification and nomenclature of cortical GABAergic interneurons. *Nat Rev Neurosci* 14: 202–16, 2013.

**DeLong MR.** Primate models of movement disorders of basal ganglia origin. *Trends Neurosci* 13: 281–5, 1990.

**Dempsey EW, Morison RS.** The interaction of certain spontaneous and induced cortical potentials. *Am J Physiol -- Leg Content* 135: 301–308, 1941.

**Descartes R.** *De Homine*. 1662.

**Desmurget M, Turner RS.** Testing basal ganglia motor functions through reversible inactivations in the posterior internal globus pallidus. *J Neurophysiol* 99: 1057–76, 2008.

**Deuschl G, Raethjen J, Baron R, Lindemann M, Wilms H, Krack P.** The pathophysiology of parkinsonian tremor: a review. *J Neurol* 247 Suppl: V33–48, 2000.

**DiMasi JA, Feldman L, Seckler A, Wilson A.** Trends in Risks Associated With New Drug Development: Success Rates for Investigational Drugs. *Clin Pharmacol & Ther* 87: 272–277, 2010.

**Dodel RC, Berger K, Oertel WH.** Health-Related Quality of Life and Healthcare Utilisation in Patients with Parkinson's Disease. *Pharmacoeconomics* 19: 1013–1038, 2001.

**Donoghue JP, Wise SP.** The motor cortex of the rat: cytoarchitecture and microstimulation mapping. *J Comp Neurol* 212: 76–88, 1982.

**Dostrovsky J, Bergmann H.** Oscillatory activity in the basal ganglia--relationship to normal physiology and pathophysiology. *Brain* 127: 721–722, 2004.

**Dum RP, Strick PL.** The origin of corticospinal projections from the premotor areas in the frontal

lobe. *J Neurosci* 11: 667–89, 1991.

**Dupre KB, Cruz A V, McCoy AJ, Delaville C, Gerber CM, Eyring KW, Walters JR.** Effects of L-dopa priming on cortical high beta and high gamma oscillatory activity in a rodent model of Parkinson's disease. *Neurobiol Dis* 86: 1–15, 2016.

**Ebrahimi A, Pochet R, Roger M.** Topographical organization of the projections from physiologically identified areas of the motor cortex to the striatum in the rat. *Neurosci Res* 14: 39–60, 1992.

**Van Den Eeden SK, Tanner CM, Bernstein AL, Fross RD, Leimpeter A, Bloch DA, Nelson LM.** Incidence of Parkinson's disease: variation by age, gender, and race/ethnicity. *Am J Epidemiol* 157: 1015–22, 2003.

**Engel AK, Fries P.** Beta-band oscillations--signalling the status quo? *Curr Opin Neurobiol* 20: 156–65, 2010.

**Fabbrini G, Brotchie JM, Grandas F, Nomoto M, Goetz CG.** Levodopa-induced dyskinesias. *Mov Disord* 22: 1379–89; quiz 1523, 2007.

**Faure A, Haberland U, Condé F, El Massioui N.** Lesion to the nigrostriatal dopamine system disrupts stimulus-response habit formation. *J Neurosci* 25: 2771–80, 2005.

**Féger J, Bevan M, Crossman AR.** The projections from the parafascicular thalamic nucleus to the subthalamic nucleus and the striatum arise from separate neuronal populations: a comparison with the corticostriatal and corticosubthalamic efferents in a retrograde fluorescent double-label. *Neuroscience* 60: 125–32, 1994.

**Fetz EE, Finocchio D V.** Correlations between activity of motor cortex cells and arm muscles during operantly conditioned response patterns. *Exp brain Res* 23: 217–40, 1975.

**Fetz EE.** Are movement parameters recognizably coded in the activity of single neurons? In: *Movement control*, edited by Cordo P, Harnad S. Cambridge: Cambridge University Press, 1994, p. 77–88.

**Fetz EE.** Restoring motor function with bidirectional neural interfaces. *Prog Brain Res* 218: 241–52, 2015.

**Fiorentini C, Rizzetti MC, Busi C, Bontempi S, Collo G, Spano P, Missale C.** Loss of synaptic D1 dopamine/N-methyl-D-aspartate glutamate receptor complexes in L-DOPA-induced dyskinesia in the rat. *Mol Pharmacol* 69: 805–12, 2006.

**Flaherty AW, Graybiel AM.** Output architecture of the primate putamen. *J Neurosci* 13: 3222–37, 1993.

- Fornal CA, Metzler CW, Gallegos RA, Veasey SC, McCreary AC, Jacobs BL.** WAY-100635, a potent and selective 5-hydroxytryptamine<sub>1A</sub> antagonist, increases serotonergic neuronal activity in behaving cats: comparison with (S)-WAY-100135. *J Pharmacol Exp Ther* 278: 752–62, 1996.
- Francardo V, Cenci MA.** Investigating the molecular mechanisms of L-DOPA-induced dyskinesia in the mouse. *Parkinsonism Relat Disord* 20 Suppl 1: S20–2, 2014.
- Fraser GW, Chase SM, Whitford A, Schwartz AB.** Control of a brain-computer interface without spike sorting. *J Neural Eng* 6: 055004, 2009.
- Friedman A, Homma D, Gibb LG, Amemori K-I, Rubin SJ, Hood AS, Riad MH, Graybiel AM.** A Corticostriatal Path Targeting Striosomes Controls Decision-Making under Conflict. *Cell* 161: 1320–33, 2015.
- Fuentes R, Petersson P, Nicolelis MAL.** Restoration of locomotive function in Parkinson's disease by spinal cord stimulation: mechanistic approach. *Eur J Neurosci* 32: 1100–1108, 2010.
- Fujisawa S, Buzsáki G.** A 4 Hz oscillation adaptively synchronizes prefrontal, VTA, and hippocampal activities. *Neuron* 72: 153–65, 2011.
- Földiák P.** Forming sparse representations by local anti-Hebbian learning. *Biol Cybern* 64: 165–70, 1990.
- Georgopoulos AP, Schwartz AB, Kettner RE.** Neuronal population coding of movement direction. *Science* 233: 1416–9, 1986.
- Georgopoulos AP.** Current issues in directional motor control. *Trends Neurosci* 18: 506–10, 1995.
- Gerfen CR, Engber TM, Mahan LC, Susel Z, Chase TN, Monsma FJ, Sibley DR.** D1 and D2 dopamine receptor-regulated gene expression of striatonigral and striatopallidal neurons. *Science* 250: 1429–32, 1990.
- Gerfen CR.** D1 dopamine receptor supersensitivity in the dopamine-depleted striatum animal model of Parkinson's disease. *Neuroscientist* 9: 455–62, 2003.
- Gerstner W, Kreiter AK, Markram H, Herz A V.** Neural codes: firing rates and beyond. *Proc Natl Acad Sci U S A* 94: 12740–1, 1997.
- Giszter SF, Mussa-Ivaldi FA, Bizzi E.** Convergent force fields organized in the frog's spinal cord. *J Neurosci* 13: 467–91, 1993.
- Gittis AH, Berke JD, Bevan MD, Chan CS, Mallet N, Morrow MM, Schmidt R.** New roles for the external globus pallidus in basal ganglia circuits and behavior. *J Neurosci* 34: 15178–83, 2014.
- Goetz CG, Stebbins GT, Chung KA, Hauser RA, Miyasaki JM, Nicholas AP, Poewe W, Seppi K,**

- Rascol O, Stacy MA, Nutt JG, Tanner CM, Urkowitz A, Jaglin JA, Ge S.** Which dyskinesia scale best detects treatment response? *Mov Disord* 28: 341–6, 2013.
- Gracheva EO, Ingolia NT, Kelly YM, Cordero-Morales JF, Hollopeter G, Chesler AT, Sánchez EE, Perez JC, Weissman JS, Julius D.** Molecular basis of infrared detection by snakes. *Nature* 464: 1006–11, 2010.
- Grafton ST, Hazeltine E, Ivry R.** Functional mapping of sequence learning in normal humans. *J Cogn Neurosci* 7: 497–510, 1995.
- Graybiel AM, Ragsdale CW.** Histochemically distinct compartments in the striatum of human, monkeys, and cat demonstrated by acetylthiocholinesterase staining. *Proc Natl Acad Sci U S A* 75: 5723–6, 1978.
- Graybiel AM.** The basal ganglia and chunking of action repertoires. *Neurobiol Learn Mem* 70: 119–36, 1998.
- Grillner S, Hellgren J, Ménard A, Saitoh K, Wikström MA.** Mechanisms for selection of basic motor programs--roles for the striatum and pallidum. *Trends Neurosci* 28: 364–70, 2005.
- Guigoni C, Doudnikoff E, Li Q, Bloch B, Bezard E.** Altered D(1) dopamine receptor trafficking in parkinsonian and dyskinetic non-human primates. *Neurobiol Dis* 26: 452–63, 2007.
- Guillery RW.** Anatomical pathways that link perception and action. *Prog Brain Res* 149: 235–56, 2005.
- Gödel K.** Über formal unentscheidbare Sätze der Principia Mathematica und verwandter Systeme I. *Monatshefte für Math Phys* 38: 173–198, 1931.
- Haas LF.** Phineas Gage and the science of brain localisation. *J Neurol Neurosurg Psychiatry* 71: 761, 2001.
- Halje P, Tamtè M, Richter U, Mohammed M, Cenci MA, Petersson P.** Levodopa-induced dyskinesia is strongly associated with resonant cortical oscillations. *J Neurosci* 32: 16541–51, 2012.
- Hammond C, Bergman H, Brown P.** Pathological synchronization in Parkinson's disease: networks, models and treatments. *Trends Neurosci* 30: 357–64, 2007.
- Hazrati LN, Parent A.** Projection from the external pallidum to the reticular thalamic nucleus in the squirrel monkey. *Brain Res* 550: 142–6, 1991.
- Hebb D.** *The organization of behavior*. New York, NY: Wiley, 1949.
- Henderson JM, Carpenter K, Cartwright H, Halliday GM.** Loss of thalamic intralaminar nuclei in progressive supranuclear palsy and Parkinson's disease: clinical and therapeutic implications.

*Brain* 123 ( Pt 7: 1410–21, 2000.

**Heyers D, Manns M, Luksch H, Güntürkün O, Mouritsen H.** A visual pathway links brain structures active during magnetic compass orientation in migratory birds. *PLoS One* 2: e937, 2007.

**Hikosaka O, Kim HF, Yasuda M, Yamamoto S.** Basal ganglia circuits for reward value-guided behavior. *Annu Rev Neurosci* 37: 289–306, 2014.

**Hirsch EC.** Biochemistry of Parkinson's disease with special reference to the dopaminergic systems. *Mol Neurobiol* 9: 135–42, 1994.

**Hochberg LR, Bacher D, Jarosiewicz B, Masse NY, Simeral JD, Vogel J, Haddadin S, Liu J, Cash SS, van der Smagt P, Donoghue JP.** Reach and grasp by people with tetraplegia using a neurally controlled robotic arm. *Nature* 485: 372–5, 2012.

**Hodgkin AL, Huxley AF.** A quantitative description of membrane current and its application to conduction and excitation in nerve. *J Physiol* 117: 500–544, 1952.

**Höpfelt T, Johansson O, Goldstein M.** Chemical anatomy of the brain. *Science* 225: 1326–34, 1984.

**Ilinsky IA, Jouandet ML, Goldman-Rakic PS.** Organization of the nigrothalamocortical system in the rhesus monkey. *J Comp Neurol* 236: 315–30, 1985.

**Inase M, Buford JA, Anderson ME.** Changes in the control of arm position, movement, and thalamic discharge during local inactivation in the globus pallidus of the monkey. *J Neurophysiol* 75: 1087–1104, 1996.

**Inokawa H, Yamada H, Matsumoto N, Muranishi M, Kimura M.** Juxtacellular labeling of tonically active neurons and phasically active neurons in the rat striatum. *Neuroscience* 168: 395–404, 2010.

**Ivica N, Tamtè M, Ahmed M, Richter U, Petersson P.** Design of a high-density multi-channel electrode for multi-structure parallel recordings in rodents. *Conf Proc . Annu Int Conf IEEE Eng Med Biol Soc IEEE Eng Med Biol Soc Annu Conf* 2014: 393–6, 2014.

**Jahanshahi M, Obeso I, Rothwell JC, Obeso JA.** A fronto-striato-subthalamic-pallidal network for goal-directed and habitual inhibition. *Nat Rev Neurosci* 16: 719–32, 2015.

**Jin X, Costa RM.** Start/stop signals emerge in nigrostriatal circuits during sequence learning. *Nature* 466: 457–62, 2010.

**Jin X, Tecuapetla F, Costa RM.** Basal ganglia subcircuits distinctively encode the parsing and concatenation of action sequences. *Nat Neurosci* 17: 423–30, 2014.

**Jog MS, Kubota Y, Connolly CI, Hillegaart V, Graybiel AM.** Building neural representations of habits. *Science* 286: 1745–9, 1999.

**Johansson RS, Birznieks I.** First spikes in ensembles of human tactile afferents code complex spatial fingertip events. *Nat Neurosci* 7: 170–7, 2004.

**Kaneko T, Fujiyama F.** Complementary distribution of vesicular glutamate transporters in the central nervous system. *Neurosci Res* 42: 243–50, 2002.

**Karkanis P, Shahack-Gross R, Ayalon A, Bar-Matthews M, Barkai R, Frumkin A, Gopher A, Stiner MC.** Evidence for habitual use of fire at the end of the Lower Paleolithic: site-formation processes at Qesem Cave, Israel. *J Hum Evol* 53: 197–212, 2007.

**Kemp JM, Powell TP.** The structure of the caudate nucleus of the cat: light and electron microscopy. *Philos Trans R Soc Lond B Biol Sci* 262: 383–401, 1971.

**Kincaid AE, Zheng T, Wilson CJ.** Connectivity and convergence of single corticostriatal axons. *J Neurosci* 18: 4722–31, 1998.

**Kiyatkin EA, Rebec G V.** Dopaminergic modulation of glutamate-induced excitations of neurons in the neostriatum and nucleus accumbens of awake, unrestrained rats. *J Neurophysiol* 75: 142–53, 1996.

**Klawans HL, Goetz C, Nausieda PA, Weiner WJ.** Levodopa-induced dopamine receptor hypersensitivity. *Trans Am Neurol Assoc* 102: 80–3, 1977.

**Kleedorfer B, Lees AJ, Stern GM.** Buspirone in the treatment of levodopa induced dyskinesias. *J Neurol Neurosurg Psychiatry* 54: 376–7, 1991.

**Klein A, Sacrey L-AR, Whishaw IQ, Dunnett SB.** The use of rodent skilled reaching as a translational model for investigating brain damage and disease. *Neurosci Biobehav Rev* 36: 1030–42, 2012.

**Kravitz A V, Kreitzer AC.** Striatal mechanisms underlying movement, reinforcement, and punishment. *Physiology (Bethesda)* 27: 167–77, 2012.

**Kravitz A V., Freeze BS, Parker PRL, Kay K, Thwin MT, Deisseroth K, Kreitzer AC.** Regulation of parkinsonian motor behaviours by optogenetic control of basal ganglia circuitry. *Nature* 466: 622–626, 2010.

**Kuypers HG, Brinkman J.** Precentral projections to different parts of the spinal intermediate zone in the rhesus monkey. *Brain Res* 24: 29–48, 1970.

**Kühn AA, Tsui A, Aziz T, Ray N, Brücke C, Kupsch A, Schneider G-H, Brown P.** Pathological synchronisation in the subthalamic nucleus of patients with Parkinson's disease relates to both

bradykinesia and rigidity. *Exp Neurol* 215: 380–7, 2009.

**Lærtius D.** The skeptics: Agrippa. In: *Lives of Eminent Philosophers*. 300AD.

**Larsson LG, Rényi L, Ross SB, Svensson B, Angeby-Möller K.** Different effects on the responses of functional pre- and postsynaptic 5-HT<sub>1A</sub> receptors by repeated treatment of rats with the 5-HT<sub>1A</sub> receptor agonist 8-OH-DPAT. *Neuropharmacology* 29: 85–91, 1990.

**Lawrence DG, Kuypers HG.** The functional organization of the motor system in the monkey. I. The effects of bilateral pyramidal lesions. *Brain* 91: 1–14, 1968.

**Levy R, Hutchison WD, Lozano AM, Dostrovsky JO.** High-frequency synchronization of neuronal activity in the subthalamic nucleus of parkinsonian patients with limb tremor. *J Neurosci* 20: 7766–75, 2000.

**Lichtheim L.** On aphasia. *Brain* 7: 433–484, 1885.

**Lind G, Gällentoft L, Danielsen N, Schouenborg J, Pettersson LME.** Multiple implants do not aggravate the tissue reaction in rat brain. *PLoS One* 7: e47509, 2012.

**Lindgren HS, Andersson DR, Lagerkvist S, Nissbrandt H, Cenci MA.** L-DOPA-induced dopamine efflux in the striatum and the substantia nigra in a rat model of Parkinson's disease: temporal and quantitative relationship to the expression of dyskinesia. *J Neurochem* 112: 1465–76, 2010.

**Lindvall O, Björklund A.** The organization of the ascending catecholamine neuron systems in the rat brain as revealed by the glyoxylic acid fluorescence method. *Acta Physiol Scand Suppl* 412: 1–48, 1974.

**Lipinski C, Hopkins A.** Navigating chemical space for biology and medicine. *Nature* 432: 855–61, 2004.

**Little S, Brown P.** The functional role of beta oscillations in Parkinson's disease. *Parkinsonism Relat Disord* 20 Suppl 1: S44–8, 2014.

**Liu X, Ramirez S, Pang PT, Puryear CB, Govindarajan A, Deisseroth K, Tonegawa S.** Optogenetic stimulation of a hippocampal engram activates fear memory recall. *Nature* 484: 381–5, 2012.

**Llinás RR, Ribary U, Jeanmonod D, Kronberg E, Mitra PP.** Thalamocortical dysrhythmia: A neurological and neuropsychiatric syndrome characterized by magnetoencephalography. *Proc Natl Acad Sci U S A* 96: 15222–7, 1999.

**Llinás RR, Steriade M.** Bursting of thalamic neurons and states of vigilance. *J Neurophysiol* 95: 3297–308, 2006.



- Loeb GE, Brown IE, Scott SH.** Directional motor control. *Trends Neurosci* 19: 137–8, 1996.
- Logothetis NK, Pauls J, Augath M, Trinath T, Oeltermann A.** Neurophysiological investigation of the basis of the fMRI signal. *Nature* 412: 150–7, 2001.
- Lopez-Huerta VG, Nakano Y, Bausenwein J, Jaidar O, Lazarus M, Cherasse Y, Garcia-Munoz M, Arbuthnott G.** The neostriatum: two entities, one structure? *Brain Struct. Funct.* ( February 5, 2015). doi: 10.1007/s00429-015-1000-4.
- Lundblad M, Andersson M, Winkler C, Kirik D, Wierup N, Cenci MA.** Pharmacological validation of behavioural measures of akinesia and dyskinesia in a rat model of Parkinson's disease. *Eur J Neurosci* 15: 120–32, 2002.
- Lynn B.** Somatosensory receptors and their CNS connections. *Annu Rev Physiol* 37: 105–27, 1975.
- Ma Q.** Labeled lines meet and talk: population coding of somatic sensations. *J Clin Invest* 120: 3773–8, 2010.
- Mallet N, Schmidt R, Leventhal D, Chen F, Amer N, Boraud T, Berke JD.** Arky pallidal Cells Send a Stop Signal to Striatum. *Neuron* ( January 12, 2016). doi: 10.1016/j.neuron.2015.12.017.
- Marini G, Pianca L, Tredici G.** Descending projections arising from the parafascicular nucleus in rats: trajectory of fibers, projection pattern and mapping of terminations. *Somatosens Mot Res* 16: 207–22, 1999.
- Markram H, Toledo-Rodriguez M, Wang Y, Gupta A, Silberberg G, Wu C.** Interneurons of the neocortical inhibitory system. *Nat Rev Neurosci* 5: 793–807, 2004.
- Mathai A, Smith Y.** The corticostriatal and corticosubthalamic pathways: two entries, one target. So what? *Front Syst Neurosci* 5: 64, 2011.
- Matsumoto N, Hanakawa T, Maki S, Graybiel AM, Kimura M.** Role of [corrected] nigrostriatal dopamine system in learning to perform sequential motor tasks in a predictive manner. *J Neurophysiol* 82: 978–98, 1999.
- Matyas F, Sreenivasan V, Marbach F, Wacongne C, Barsy B, Mateo C, Aronoff R, Petersen CCH.** Motor control by sensory cortex. *Science* 330: 1240–3, 2010.
- McFarland NR, Haber SN.** Thalamic relay nuclei of the basal ganglia form both reciprocal and nonreciprocal cortical connections, linking multiple frontal cortical areas. *J Neurosci* 22: 8117–32, 2002.
- Meister M, Bonhoeffer T.** Tuning and topography in an odor map on the rat olfactory bulb. *J Neurosci* 21: 1351–60, 2001.

- Merker B.** Consciousness without a cerebral cortex: a challenge for neuroscience and medicine. *Behav Brain Sci* 30: 63–81; discussion 81–134, 2007.
- Meiners R.** The modification of alternating tremors, rigidity and festination by surgery of the basal ganglia. *A Res Nerv MentDis* 20: 602–665, 1942.
- Middleton FA, Strick PL.** Basal ganglia and cerebellar loops: motor and cognitive circuits. *Brain Res Brain Res Rev* 31: 236–50, 2000.
- Mink JW.** The basal ganglia: focused selection and inhibition of competing motor programs. *Prog Neurobiol* 50: 381–425, 1996.
- Miocinovic S, Somayajula S, Chitnis S, Vitek JL.** History, applications, and mechanisms of deep brain stimulation. *JAMA Neurol* 70: 163–71, 2013.
- Mitzdorf U.** Current source-density method and application in cat cerebral cortex: investigation of evoked potentials and EEG phenomena. *Physiol Rev* 65: 37–100, 1985.
- Monakow KH, Akert K, Künzle H.** Projections of the precentral motor cortex and other cortical areas of the frontal lobe to the subthalamic nucleus in the monkey. *Exp brain Res* 33: 395–403, 1978.
- Moritz CT, Lucas TH, Perlmutter SI, Fetz EE.** Forelimb movements and muscle responses evoked by microstimulation of cervical spinal cord in sedated monkeys. *J Neurophysiol* 97: 110–20, 2007.
- Moritz CT, Perlmutter SI, Fetz EE.** Direct control of paralysed muscles by cortical neurons. *Nature* 456: 639–42, 2008.
- Mountcastle VB.** The columnar organization of the neocortex. *Brain* 120 ( Pt 4: 701–22, 1997.
- Muñoz A, Li Q, Gardoni F, Marcello E, Qin C, Carlsson T, Kirik D, Di Luca M, Björklund A, Bezard E, Carta M.** Combined 5-HT1A and 5-HT1B receptor agonists for the treatment of L-DOPA-induced dyskinesia. *Brain* 131: 3380–94, 2008.
- Mussa-Ivaldi FA, Giszter SF, Bizzi E.** Linear combinations of primitives in vertebrate motor control. *Proc Natl Acad Sci U S A* 91: 7534–8, 1994.
- Nadjar A, Gerfen CR, Bezard E.** Priming for l-dopa-induced dyskinesia in Parkinson’s disease: a feature inherent to the treatment or the disease? *Prog Neurobiol* 87: 1–9, 2009.
- Nambu A, Takada M, Inase M, Tokuno H.** Dual somatotopical representations in the primate subthalamic nucleus: evidence for ordered but reversed body-map transformations from the primary motor cortex and the supplementary motor area. *J Neurosci* 16: 2671–83, 1996.

- Nambu A, Tokuno H, Takada M.** Functional significance of the cortico-subthalamo-pallidal “hyperdirect” pathway. *Neurosci Res* 43: 111–7, 2002.
- Nambu A.** A new dynamic model of the cortico-basal ganglia loop. *Prog Brain Res* 143: 461–6, 2004.
- Nambu A.** Seven problems on the basal ganglia. *Curr Opin Neurobiol* 18: 595–604, 2008.
- Nanhoe-Mahabier W, de Laat KF, Visser JE, Zijlmans J, de Leeuw F-E, Bloem BR.** Parkinson disease and comorbid cerebrovascular disease. *Nat Rev Neurol* 5: 533–41, 2009.
- Nestler EJ, Hyman SE.** Animal models of neuropsychiatric disorders. *Nat Neurosci* 13: 1161–1169, 2010.
- Nicolelis M.** *Methods for Neural Ensemble Recordings*. 2nd ed. Boca Raton, FL: CRC Press/Taylor & Francis, 2008.
- Nicolelis MA, De Oliveira LM, Lin RC, Chapin JK.** Active tactile exploration influences the functional maturation of the somatosensory system. *J Neurophysiol* 75: 2192–6, 1996.
- Nicolelis MAL, Dimitrov D, Carmena JM, Crist R, Lehew G, Kralik JD, Wise SP.** Chronic, multisite, multielectrode recordings in macaque monkeys. *Proc Natl Acad Sci U S A* 100: 11041–6, 2003.
- Novales I.** The ontogeny of ultraviolet sensitivity, cone disappearance and regeneration in the sockeye salmon *Oncorhynchus nerka*. *J Exp Biol* 203: 1161–72, 2000.
- Obeso JA, Rodriguez-Oroz MC, Stamelou M, Bhatia KP, Burn DJ.** The expanding universe of disorders of the basal ganglia. *Lancet* 384: 523–531, 2014.
- Oorschot DE.** Total number of neurons in the neostriatal, pallidal, subthalamic, and substantia nigral nuclei of the rat basal ganglia: a stereological study using the cavalieri and optical disector methods. *J Comp Neurol* 366: 580–99, 1996.
- Ostock CY, Dupre KB, Jaunarajs KLE, Walters H, George J, Krolewski D, Walker PD, Bishop C.** Role of the primary motor cortex in L-Dopa-induced dyskinesia and its modulation by 5-HT<sub>1A</sub> receptor stimulation. *Neuropharmacology* 61: 753–60, 2011.
- Palmér T, Tamtè M, Halje P, Enqvist O, Petersson P.** A system for automated tracking of motor components in neurophysiological research. *J Neurosci Methods* 205: 334–44, 2012.
- Parent A, Hazrati LN.** Functional anatomy of the basal ganglia. I. The cortico-basal ganglia-thalamo-cortical loop. *Brain Res Brain Res Rev* 20: 91–127, 1995.
- Parkinson J.** *An Essay on the Shaking Palsy*. London: Whittingham and Rowland for Sherwood,

Neely & Jones, 1817.

**Parmenides.** Parmenides' poem. 500BC, p. section 8, row 25–49.

**Penfield W, Boldrey E.** SOMATIC MOTOR AND SENSORY REPRESENTATION IN THE CEREBRAL CORTEX OF MAN AS STUDIED BY ELECTRICAL STIMULATION. *Brain* : 389, 1937.

**Petersson P, Waldenström A, Fåhraeus C, Schouenborg J.** Spontaneous muscle twitches during sleep guide spinal self-organization. *Nature* 424: 72–5, 2003.

**Picconi B, Centonze D, Håkansson K, Bernardi G, Greengard P, Fisone G, Cenci MA, Calabresi P.** Loss of bidirectional striatal synaptic plasticity in L-DOPA-induced dyskinesia. *Nat Neurosci* 6: 501–6, 2003.

**Pourcher E, Bonnet AM, Kefalos J, Dubois B, Agid Y.** Effects of etybenzatropine and diazepam on levodopa-induced diphasic dyskinesias in Parkinson's disease. *Mov Disord* 4: 195–201, 1989.

**Press W.** Flicker noises in astronomy and elsewhere. *Comments Astrophys* 7: 103–119, 1978.

**Purves D, Augustine G, Fitzpatrick D.** Circuits within the Basal Ganglia System. In: *Neuroscience, 2nd edition*. Sunderland (MA): Sinauer Associates, 2001.

**Quiroga-Varela A, Walters JR, Brazhnik E, Marin C, Obeso JA.** What basal ganglia changes underlie the parkinsonian state? The significance of neuronal oscillatory activity. *Neurobiol Dis* 58: 242–8, 2013.

**Rascol O, Sabatini U, Brefel C, Fabre N, Rai S, Senard JM, Celsis P, Viallard G, Montastruc JL, Chollet F.** Cortical motor overactivation in parkinsonian patients with L-dopa-induced peak-dose dyskinesia. *Brain* 121 ( Pt 3: 527–33, 1998.

**Ray JP, Price JL.** The organization of the thalamocortical connections of the mediodorsal thalamic nucleus in the rat, related to the ventral forebrain-prefrontal cortex topography. *J Comp Neurol* 323: 167–97, 1992.

**Raz A, Frechter-Mazar V, Feingold A, Abeles M, Vaadia E, Bergman H.** Activity of pallidal and striatal tonically active neurons is correlated in mptp-treated monkeys but not in normal monkeys. *J Neurosci* 21: RC128, 2001.

**Redgrave P, Gurney K, Reynolds J.** What is reinforced by phasic dopamine signals? *Brain Res Rev* 58: 322–39, 2008.

**Rexed B.** The cytoarchitectonic organization of the spinal cord in the cat. *J Comp Neurol* 96: 414–95, 1952.

**Richter U, Halje P, Petersson P.** Mechanisms underlying cortical resonant states: implications for levodopa-induced dyskinesia. *Rev Neurosci* 24: 415–29, 2013.

**Riehle A, Requin J.** Neuronal correlates of the specification of movement direction and force in four cortical areas of the monkey. *Behav Brain Res* 70: 1–13, 1995.

**de Rijk MC, Breteler MM, Graveland GA, Ott A, Grobbee DE, van der Meché FG, Hofman A.** Prevalence of Parkinson's disease in the elderly: the Rotterdam Study. *Neurology* 45: 2143–6, 1995.

**Rorschach H.** *Rorschach Test – Psychodiagnostic Plates*. Cambridge, MA: Hogrefe Publishing Corp, 1927.

**Rose J, Woolsey C.** The orbitofrontal cortex and its connections with the mediodorsal nucleus in rabbit, sheep and cat. *Res Publ Assoc Res Nerv Ment Dis* 27 (1 vol.: 210–32, 1948.

**Rosén I, Asanuma H.** Peripheral afferent inputs to the forelimb area of the monkey motor cortex: input-output relations. *Exp brain Res* 14: 257–73, 1972.

**Rylander D, Parent M, O'Sullivan SS, Dovero S, Lees AJ, Bezard E, Descarries L, Cenci MA.** Maladaptive plasticity of serotonin axon terminals in levodopa-induced dyskinesia. *Ann Neurol* 68: 619–28, 2010.

**Sadikot AF, Parent A, François C.** Efferent connections of the centromedian and parafascicular thalamic nuclei in the squirrel monkey: a PHA-L study of subcortical projections. *J Comp Neurol* 315: 137–59, 1992.

**Sano H, Chiken S, Hikida T, Kobayashi K, Nambu A.** Signals through the striatopallidal indirect pathway stop movements by phasic excitation in the substantia nigra. *J Neurosci* 33: 7583–94, 2013.

**Sawada M, Kato K, Kunieda T, Mikuni N, Miyamoto S, Onoe H, Isa T, Nishimura Y.** Function of the nucleus accumbens in motor control during recovery after spinal cord injury. *Science* 350: 98–101, 2015.

**Schouenborg J, Weng HR.** Sensorimotor transformation in a spinal motor system. *Exp brain Res* 100: 170–4, 1994.

**Schrag A, Quinn N.** Dyskinesias and motor fluctuations in Parkinson's disease. A community-based study. *Brain* 123 ( Pt 1: 2297–305, 2000.

**Schultz W, Dayan P, Montague PR.** A neural substrate of prediction and reward. *Science* 275: 1593–9, 1997.

**Schultz W.** Predictive reward signal of dopamine neurons. *J Neurophysiol* 80: 1–27, 1998.

**Seamans JK, Yang CR.** The principal features and mechanisms of dopamine modulation in the

prefrontal cortex. *Prog Neurobiol* 74: 1–58, 2004.

**Sherman SM, Guillery RW.** Functional organization of thalamocortical relays. *J Neurophysiol* 76: 1367–95, 1996.

**Sherman SM, Guillery RW.** Distinct functions for direct and transthalamic corticocortical connections. *J Neurophysiol* 106: 1068–77, 2011.

**Sherman SM.** Thalamic relays and cortical functioning. *Prog Brain Res* 149: 107–26, 2005.

**Sidibé M, Smith Y.** Differential synaptic innervation of striatofugal neurones projecting to the internal or external segments of the globus pallidus by thalamic afferents in the squirrel monkey. *J Comp Neurol* 365: 445–65, 1996.

**Silberberg G, Markram H.** Disynaptic inhibition between neocortical pyramidal cells mediated by Martinotti cells. *Neuron* 53: 735–46, 2007.

**Silverdale MA, Kobylecki C, Hallett PJ, Li Q, Dunah AW, Ravenscroft P, Bezard E, Brotchie JM.** Synaptic recruitment of AMPA glutamate receptor subunits in levodopa-induced dyskinesia in the MPTP-lesioned nonhuman primate. *Synapse* 64: 177–80, 2010.

**Skinner BF.** Superstition in the pigeon. *J Exp Psychol* 38: 168–72, 1948.

**Smith AD, Bolam JP.** The neural network of the basal ganglia as revealed by the study of synaptic connections of identified neurones. *Trends Neurosci* 13: 259–65, 1990.

**Smith Y, Galvan A, Ellender TJ, Doig N, Villalba RM, Huerta-Ocampo I, Wichmann T, Bolam JP.** The thalamostriatal system in normal and diseased states. *Front Syst Neurosci* 8, 2014.

**Smith Y, Raju D V, Pare J-F, Sidibe M.** The thalamostriatal system: a highly specific network of the basal ganglia circuitry. *Trends Neurosci* 27: 520–7, 2004.

**Smith Y, Villalba R.** Striatal and extrastriatal dopamine in the basal ganglia: an overview of its anatomical organization in normal and Parkinsonian brains. *Mov Disord* 23 Suppl 3: S534–47, 2008.

**Spruston N.** Pyramidal neurons: dendritic structure and synaptic integration. *Nat Rev Neurosci* 9: 206–21, 2008.

**van der Staay FJ, Arndt SS, Nordquist RE.** Evaluation of animal models of neurobehavioral disorders. *Behav Brain Funct* 5: 11, 2009.

**Staba RJ, Bragin A.** High-frequency oscillations and other electrophysiological biomarkers of epilepsy: underlying mechanisms. *Biomark Med* 5: 545–56, 2011.

**Steriade M, McCormick DA, Sejnowski TJ.** Thalamocortical oscillations in the sleeping and aroused brain. *Science* 262: 679–85, 1993.

**Stocco A, Lebiere C, Anderson JR.** Conditional routing of information to the cortex: A model of the basal ganglia's role in cognitive coordination. *Psychol Rev* 117: 541–574, 2010.

**Surmeier DJ, Eberwine J, Wilson CJ, Cao Y, Stefani A, Kitai ST.** Dopamine receptor subtypes colocalize in rat striatonigral neurons. *Proc Natl Acad Sci U S A* 89: 10178–82, 1992.

**Swanson LW.** Cerebral hemisphere regulation of motivated behavior. *Brain Res* 886: 113–164, 2000.

**Svenningsson P, Rosenblad C, af Edholm Arvidsson K, Wictorin K, Keywood C, Shankar B, Lowe DA, Bjorklund A, Widner H.** Eltoprazine counteracts L-DOPA-induced dyskinesias in Parkinson's disease: a dose-finding study. *Brain* 138: 963–973, 2015.

**Tamtè M, Brys I, Richter U, Ivica N, Halje P, Petersson P.** Systems level neurophysiological state characteristics for drug evaluation in an animal model of levodopa-induced dyskinesia. *J Neurophysiol.* ( January 6, 2016). doi: 10.1152/jn.00868.2015.

**Tanaka H, Kannari K, Maeda T, Tomiyama M, Suda T, Matsunaga M.** Role of serotonergic neurons in L-DOPA-derived extracellular dopamine in the striatum of 6-OHDA-lesioned rats. *Neuroreport* 10: 631–4, 1999.

**Tanji J, Shima K.** Role for supplementary motor area cells in planning several movements ahead. *Nature* 371: 413–6, 1994.

**Thach WT.** Correlation of neural discharge with pattern and force of muscular activity, joint position, and direction of intended next movement in motor cortex and cerebellum. *J Neurophysiol* 41: 654–76, 1978.

**Thorn CA, Atallah H, Howe M, Graybiel AM.** Differential dynamics of activity changes in dorsolateral and dorsomedial striatal loops during learning. *Neuron* 66: 781–95, 2010.

**Todorov E, Ghahramani Z.** Unsupervised learning of sensory-motor primitives. In: *In Proceedings of the 25th Annual International Conference of the IEEE Engineering in Biology and Medicine Society.* 2003, p. 1750–1753.

**Todorov E.** Direct cortical control of muscle activation in voluntary arm movements: a model. *Nat Neurosci* 3: 391–8, 2000.

**Toledo JB, López-Azcárate J, Garcia-Garcia D, Guridi J, Valencia M, Artieda J, Obeso J, Alegre M, Rodriguez-Oroz M.** High beta activity in the subthalamic nucleus and freezing of gait in Parkinson's disease. *Neurobiol Dis* 64: 60–5, 2014.

- Toni I, Krams M, Turner R, Passingham RE.** The time course of changes during motor sequence learning: a whole-brain fMRI study. *Neuroimage* 8: 50–61, 1998.
- Tresch MC, Bizzi E.** Responses to spinal microstimulation in the chronically spinalized rat and their relationship to spinal systems activated by low threshold cutaneous stimulation. *Exp Brain Res* 129: 401–16, 1999.
- Tresch MC, Saltiel P, Bizzi E.** The construction of movement by the spinal cord. *Nat Neurosci* 2: 162–7, 1999.
- Ueki A, Uno M, Anderson M, Yoshida M.** Monosynaptic inhibition of thalamic neurons produced by stimulation of the substantia nigra. *Experientia* 33: 1480–2, 1977.
- Uhl GR, Hedreen JC, Price DL.** Parkinson's disease: loss of neurons from the ventral tegmental area contralateral to therapeutic surgical lesions. *Neurology* 35: 1215–8, 1985.
- Ungerstedt U.** 6-Hydroxy-dopamine induced degeneration of central monoamine neurons. *Eur J Pharmacol* 5: 107–10, 1968.
- Varela C.** Thalamic neuromodulation and its implications for executive networks. *Front Neural Circuits* 8: 69, 2014.
- Watts DJ, Strogatz SH.** Collective dynamics of “small-world” networks. *Nature* 393: 440–2, 1998.
- Wayner MJ.** Motor control functions of the lateral hypothalamus and adjunctive behavior. *Physiol Behav* 5: 1319–25, 1970.
- Weiss JL, Ng LK, Chase TN.** Long-lasting dyskinesia induced by levodopa. *Lancet (London, England)* 1: 1016–7, 1971.
- Velliste M, Perel S, Spalding MC, Whitford AS, Schwartz AB.** Cortical control of a prosthetic arm for self-feeding. *Nature* 453: 1098–101, 2008.
- West MO, Carelli RM, Pomerantz M, Cohen SM, Gardner JP, Chapin JK, Woodward DJ.** A region in the dorsolateral striatum of the rat exhibiting single-unit correlations with specific locomotor limb movements. *J Neurophysiol* 64: 1233–46, 1990.
- Whishaw IQ, Pellis SM.** The structure of skilled forelimb reaching in the rat: a proximally driven movement with a single distal rotatory component. *Behav Brain Res* 41: 49–59, 1990.
- Whishaw IQ, Whishaw P, Gorny B.** The structure of skilled forelimb reaching in the rat: a movement rating scale. *J Vis Exp*, 2008.
- Wickens JR, Reynolds JNJ, Hyland BI.** Neural mechanisms of reward-related motor learning. *Curr Opin Neurobiol* 13: 685–90, 2003.



**Vilela-Filho O, Barros BA, Arruda MM, Castro TS, Souza JT, Silva DJ, Ferraz FP, Ragazzo PC.** Striatal somatotopy and motor responses evoked by acute electrical stimulation of the posterior striatum in rats. *Neuromodulation* 17: 119–25, 2014.

**Wilson CJ, Kawaguchi Y.** The origins of two-state spontaneous membrane potential fluctuations of neostriatal spiny neurons. *J Neurosci* 16: 2397–410, 1996.

**Wilson CJ.** The generation of natural firing patterns in neostriatal neurons. *Prog Brain Res* 99: 277–97, 1993.

**Wolbring G, Diep L, Yumakulov S, Ball N, Yergens D.** Social Robots, Brain Machine Interfaces and Neuro/Cognitive Enhancers: Three Emerging Science and Technology Products through the Lens of Technology Acceptance Theories, Models and Frameworks. *Technologies* 1: 3–25, 2013.

**Wolz M, Löhle M, Strecker K, Schwanebeck U, Schneider C, Reichmann H, Grähler X, Schwarz J, Storch A.** Levetiracetam for levodopa-induced dyskinesia in Parkinson's disease: a randomized, double-blind, placebo-controlled trial. *J Neural Transm* 117: 1279–86, 2010.

**Wu Y, Richard S, Parent A.** The organization of the striatal output system: a single-cell juxtacellular labeling study in the rat. *Neurosci Res* 38: 49–62, 2000.

**Wächter T, Röhrich S, Frank A, Molina-Luna K, Pekanovic A, Hertler B, Schubring-Giese M, Luft AR.** Motor skill learning depends on protein synthesis in the dorsal striatum after training. *Exp brain Res* 200: 319–23, 2010.

**Yang H, Kwon SE, Severson KS, O'Connor DH.** Origins of choice-related activity in mouse somatosensory cortex. *Nat Neurosci* 19: 127–34, 2016.

**Yuste R, MacLean JN, Smith J, Lansner A.** The cortex as a central pattern generator. *Nat Rev Neurosci* 6: 477–83, 2005.

**Zeno of Elea.** Zeno's Arrow. In: *Aristoteles' Physics (VI)*. 350BC, p. part 2 & 9.

**Zhou F-M, Wilson CJ, Dani JA.** Cholinergic interneuron characteristics and nicotinic properties in the striatum. *J Neurobiol* 53: 590–605, 2002.