



LUND UNIVERSITY

Control Problems at the European Spallation Source

Troeng, Olof; Olofsson, Björn; Bernhardsson, Bo; Johansson, Anders J; Johansson, Rolf

Published in:
Abstracts of Reglermöte 2016

2016

[Link to publication](#)

Citation for published version (APA):
Troeng, O., Olofsson, B., Bernhardsson, B., Johansson, A. J., & Johansson, R. (2016). Control Problems at the European Spallation Source. In *Abstracts of Reglermöte 2016*

Total number of authors:
5

General rights

Unless other specific re-use rights are stated the following general rights apply:
Copyright and moral rights for the publications made accessible in the public portal are retained by the authors and/or other copyright owners and it is a condition of accessing publications that users recognise and abide by the legal requirements associated with these rights.

- Users may download and print one copy of any publication from the public portal for the purpose of private study or research.
- You may not further distribute the material or use it for any profit-making activity or commercial gain
- You may freely distribute the URL identifying the publication in the public portal

Read more about Creative commons licenses: <https://creativecommons.org/licenses/>

Take down policy

If you believe that this document breaches copyright please contact us providing details, and we will remove access to the work immediately and investigate your claim.

LUND UNIVERSITY

PO Box 117
221 00 Lund
+46 46-222 00 00

Control Problems at the European Spallation Source

Olof Troeng* Björn Olofsson* Bo Bernhardsson*
Anders J Johansson** Rolf Johansson*

* Department of Automatic Control, Lund University
E-mail: {oloft, bjorno, bob, Rolf.Johansson}@control.lth.se
** Department of Electrical and Information Tech., Lund University
E-mail: anders_j.johansson@eit.lth.se

1. THE EUROPEAN SPALLATION SOURCE

The European Spallation Source (ESS), currently under construction in Lund, will be the world's brightest neutron source, allowing researchers to see and understand previously invisible structures in for example superconducting materials, pharmaceuticals, solar cells, fuel cells, catalysts, and engineering materials. The neutrons will be generated by smashing protons, traveling at 96 % the speed of light, into a tungsten target. For illustrations see Figures 1-3.

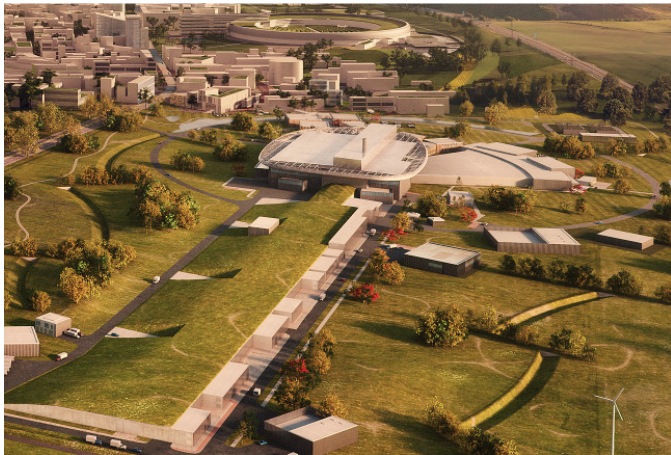

Fig. 1. Visualization of ESS' architectural design. In the distance the world's most brilliant synchrotron light source, MAX IV, is seen. Photo credit: ESS.

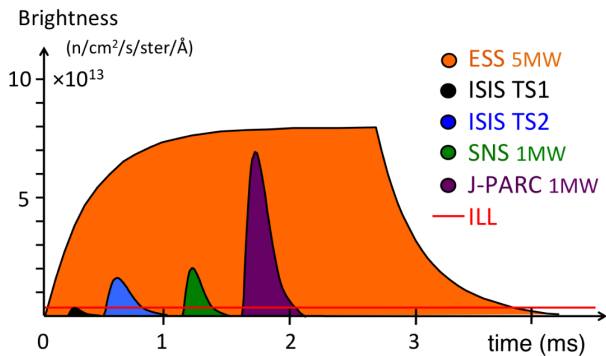

Fig. 2. Single-pulse brightness for the world's leading neutron sources at 5 Å wavelength, Peggs et al. (2013).

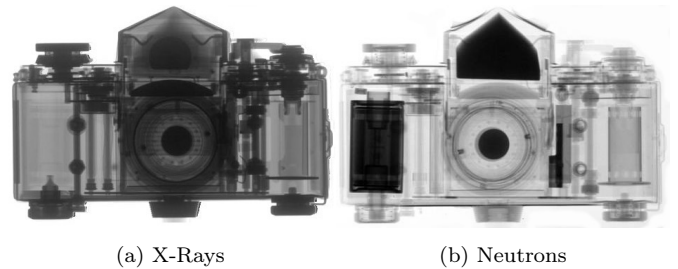

Fig. 3. Different details appear in the two images due to that neutrons and X-rays are attenuated differently. Photo credit: PSI.

The protons will be accelerated by electromagnetic fields confined in 155 radio-frequency cavities along the 500 meter long, most powerful linear accelerator ever built (Figure 4). The first nine cavities (one radio frequency quadrupole, three bunchers, five drift tube linacs) are made of copper and operated at around room temperature. The succeeding cavities are made of niobium and cooled by liquid helium to 2 K, making them superconducting and allowing stronger electric fields and lower electrical losses.

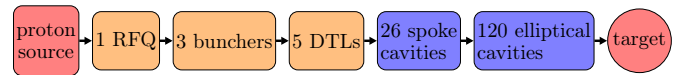

Fig. 4. Block diagram of the ESS accelerator.

Radioactivation due to escaped protons will be significant around the accelerator. For this reason the accelerator is placed in an underground tunnel while all electronic equipment is kept in buildings at the surface. The high charge density of the accelerated proton bunches puts unprecedented requirements on amplitude and phase stability of the cavity fields to keep activation within tolerable levels.

At the Department of Automatic Control at Lund University we are working with control design for the amplitude and phase regulation, and also temperature stabilization for the distribution of the phase reference. We are also involved in the control design for damping the mechanical resonances in the superconducting cavities that are excited by the photon pressure of the pulsed electric fields. These three control problems are briefly introduced below. The space does not allow us to go into details but more background and experimental results will be presented at the meeting.

2. CAVITY FIELD CONTROL

The block diagram of a single RF station is shown in Figure 5. The dynamics for the electric modes in the cavity are given by

$$\ddot{e}_k(t) + 2\alpha_k \dot{e}_k(t) + \omega_k^2 e_k(t) = \kappa_{gk} \dot{i}_g(t) + \kappa_{bk} \dot{i}_b(t), \quad (1)$$

where ω_k is the resonance frequency and α_k the half bandwidth of mode k . The parameters κ_{gk} and κ_{bk} quantify how the power supplied by the power amplifier, modeled as a current i_g , and how the accelerated particle bunches, modeled as a current i_b , couple to the cavity field. The control system is able to modulate i_g , which acts as the control input.

The objective is to control the accelerating mode, which has a frequency matched to the proton bunch frequency. Analysis and controller implementation is done in the base-band ($s \mapsto s - i\omega_{\text{RF}}$) around the nominal RF frequency ω_{RF} . Considering the accelerating mode and the closest parasitic mode, a linear model is given by

$$P(s) = P_{\text{PA}}(s) e^{-i\omega_{\text{RF}}\tau} e^{-\tau s} \times \left[\frac{c_0 \kappa_{g0}/2}{s + \alpha_0 \omega_0 + i\Delta\omega_0} + \frac{c_1 \kappa_{g1}/2}{s + \alpha_1 \omega_1 + i\Delta\omega_1} \right], \quad (2)$$

where $\Delta\omega_k = \omega_{\text{RF}} - \omega_k$, c_k describe the coupling to the measurement probe, τ is the system time delay and $P_{\text{PA}}(s)$ is the linearized amplifier dynamics. Note that the process transfer function (2) contains multiple complex coefficients (colored blue). We have realized that complex transfer functions offer improved insight compared to considering (2) as a real two-input two-output system which is done in the cavity field control literature.

The controller will be implemented in an FPGA, allowing sampling speeds of 10 MHz. The bandwidth of the field control loops will be around 100 kHz for the warm cavities and 30 kHz for the cold cavities. It is interesting to note that most of the limitations on the bandwidth and control performance are due to the 1 μs time delay τ .

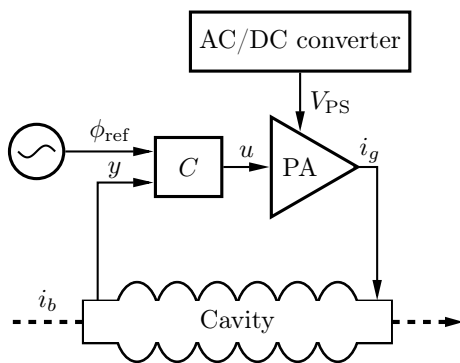

Fig. 5. Block diagram of RF station driving one cavity. Variations in the voltage V_{PS} supplied to the power amplifier and the accelerated current i_b affect the system as load disturbances on the cavity input. Temperature regulation of the line between the reference oscillator and the controller is discussed in Section 3.

3. TEMPERATURE CONTROL OF PHASE REFERENCE LINE

The phase setpoints of all cavities are given relative the phase of an ultra-stable reference clock. The phase reference is distributed along the accelerator as an electromagnetic wave in a rigid coaxial line made of copper. Variations in the air temperature of the tunnel induce length variations of the coaxial line and consequently changes the phase of the wave at the tap points. These variations will be counter-acted by insulating the reference line and mounting temperature sensors and heating elements inside the insulation. The heating power is controlled by PI controllers, with one controller for every 10–20 m.

The requirement on phase stability of the reference signals translates to a requirement on temperature stability of $\pm 0.1^\circ\text{C}$. Experimental results from a prototype setup have demonstrated that the system achieves the required stability when subject to sinusoidal variations in the air temperature with a period of 1 h and an amplitude of 5°C .

4. TUNING CONTROL

The superconducting cavities, made of thin (4 mm) niobium, deform due to the photon pressure of the electric fields. This changes the resonance frequency of the cavities, increasing the required power to maintain the fields at the nominal frequency. To counter-act time-varying deformations the cavities are equipped with stepper motors for slow, coarse tuning and fast piezo-tuners for precision tuning. Both feedback and feedforward will be used in the tuning control algorithms.

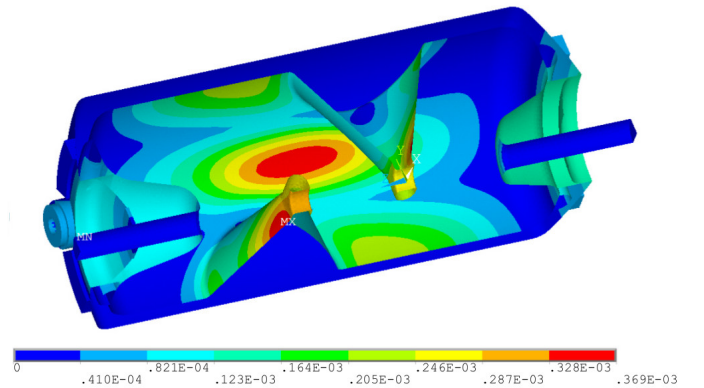

Fig. 6. Expected Lorenz force detuning of ESS spoke cavity, in millimeters, Peggs et al. (2013).

ACKNOWLEDGEMENTS

We would like to acknowledge helpful discussions with people at ESS, Lund University and accelerator facilities that we have visited.

REFERENCES

Peggs, S. et al. (2013). ESS technical design report. Technical Report ESS-doc-274.