



LUND UNIVERSITY

Activity Report: Automatic Control 2016

Giselsson, Pontus; Rasmusson, Monika

2017

Document Version:

Publisher's PDF, also known as Version of record

[Link to publication](#)

Citation for published version (APA):

Giselsson, P., & Rasmusson, M. (Eds.) (2017). *Activity Report: Automatic Control 2016*. (Annual Reports TFRT-4044). Department of Automatic Control, Lund Institute of Technology, Lund University.

Total number of authors:

2

General rights

Unless other specific re-use rights are stated the following general rights apply:

Copyright and moral rights for the publications made accessible in the public portal are retained by the authors and/or other copyright owners and it is a condition of accessing publications that users recognise and abide by the legal requirements associated with these rights.

- Users may download and print one copy of any publication from the public portal for the purpose of private study or research.
- You may not further distribute the material or use it for any profit-making activity or commercial gain
- You may freely distribute the URL identifying the publication in the public portal

Read more about Creative commons licenses: <https://creativecommons.org/licenses/>

Take down policy

If you believe that this document breaches copyright please contact us providing details, and we will remove access to the work immediately and investigate your claim.

LUND UNIVERSITY

PO Box 117
221 00 Lund
+46 46-222 00 00



Activity Report 2016

AUTOMATIC CONTROL | LUND UNIVERSITY



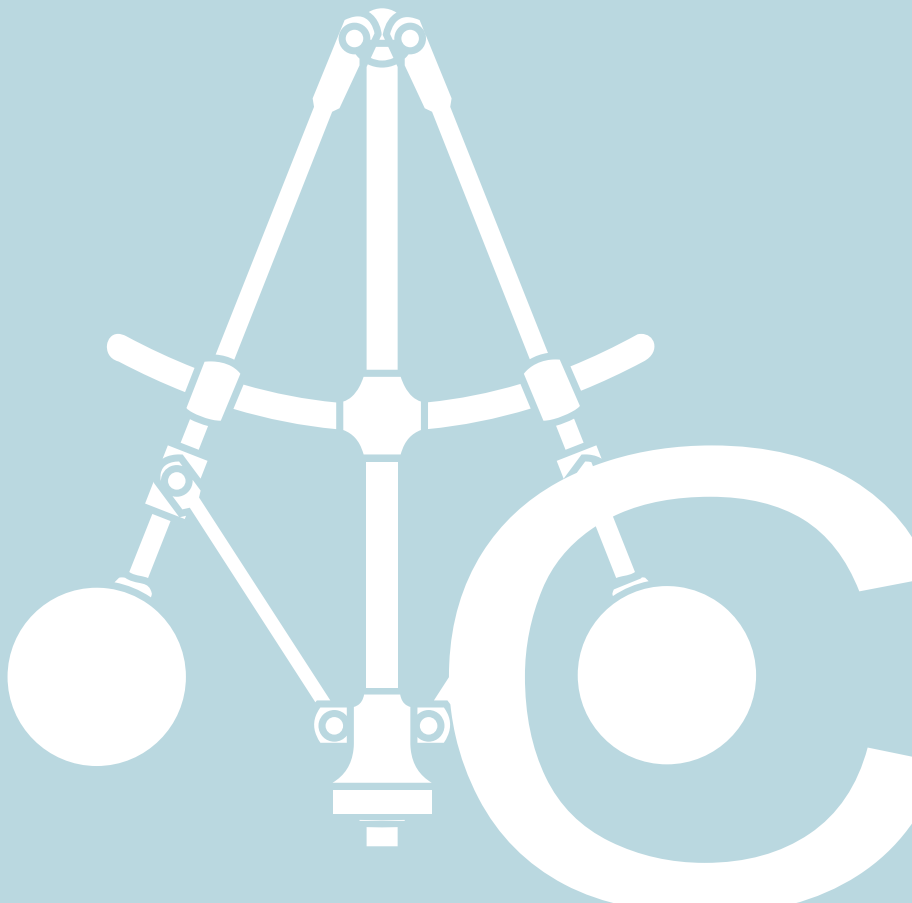

Activity Report 2016



LUND
UNIVERSITY

Department of Automatic Control

MAILING ADDRESS

Department of Automatic Control
Lund University
P O Box 118
SE-221 00 LUND, Sweden

VISITING ADDRESS

Institutionen för Reglerteknik
Ole Römers väg 1
223 63 LUND

TELEPHONE

+46 46 222 87 87

WWW AND GENERIC E-MAIL ADDRESS

www.control.lth.se
control@control.lth.se

Edited by Pontus Giselsson and Monika Rasmusson

Printed: Media-Tryck, Lund, Sweden, March 2017

ISSN 0280-5316

Annual Report TFRT--4044



Content

Introduction	7
AUTOMATIC CONTROL 2016	9
Education	11
BASIC LEVEL.....	12
PHD STUDIES	14
LICENTIATE DISSERTATIONS.....	15
DOCTORAL DISSERTATIONS.....	17
Research	23
EXCELLENCE CENTERS	24
RESEARCH AREAS	32
MODELING AND CONTROL OF COMPLEX SYSTEMS.....	33
LARGE SCALE OPTIMIZATION AND CONTROL.....	42
CONTROL AND REAL-TIME COMPUTING.....	46
PROCESS CONTROL	54
ROBOTICS.....	62
AUTOMOTIVE SYSTEMS	67
BIOMEDICAL PROJECTS	68
TOOLS AND SOFTWARE	71
External Contacts	73
ACADEMIC CONTACTS.....	74
INDUSTRIAL CONTACTS.....	75
EUROPEAN COLLABORATIONS	76
Staff	77
STAFF.....	79
STAFF ACTIVITIES	80
AWARDS	90
ASSIGNMENTS.....	91
Economy	97
ECONOMY.....	98
FUNDING.....	99
Appendix	101
PUBLICATIONS 2016.....	102
SEMINARS AT THE DEPARTMENT	110
LECTURES BY STAFF OUTSIDE THE DEPARTMENT	112
POPULAR SCIENCE PRESENTATIONS	115

Introduction

This report describes the main activities at the Department of Automatic Control at Lund University during the period January 1 to December 31, 2016



AUTOMATIC CONTROL 2016

The year 2016 was a year with quite a few events, both internally and externally.

The administrative group engaged in a project called "The short way to work" where we guided Shorok, an Israeli woman, in better understanding the Swedish system for getting a job.

In March we celebrated 1 000 Master's Theses projects being completed at Automatic Control. No 1 000 was written by Sandra Collin, and the title of her work was *Kinematic Robot Calibration Using a Double Ball-Bar*.

We also spent a day going through all processes that are part of our different courses. All personnel at the department were engaged and decisions were taken in order to better meet new challenges from now on, but also to improve our processes.

In June, the Automatic Control meeting was held at Chalmers, in Gothenburg. This meeting takes place every second year and invites all staff i.e. researchers, PhDs, postdocs, teachers and administrators. The next meeting will be held at KTH, Stockholm in 2018.

In September, The Lund Center for Control of Complex Systems (LCCC) hosted a workshop on Process Control, organized by staff from the department, in collaboration with the Process Industrial Centre at Lund University (PICLU). It was held at the Pufendorf Institute in Lund. The workshop consisted of a series of talks by invited world leading academic and industrial experts, and interactive thematic sessions, summarized in a panel discussion.

End November the now well established EURobotics week took place at our RobotLab. During this week, 21 one-hour-long guided tours were arranged. About 500 school children and students of all ages from 18 different regional schools took part in the tours. During special sessions, another 50 adults from the public (including some from within Lund University).

Different demos were included in the tours, such as: Robot doing free-form hot-wire cutting in styrofoam; Interaction and programming of a dual-arm robot by lead-through motions; Parallel kinematic manipulators; Simultaneous localization and mapping for mobile robots; Natural-language programming of an industrial robot; Tactile/haptic feedback for operator interface.

The department in numbers is summarized below:

The economy showed a turnover for 2016 (2015) of 57 MSEK (53 MSEK) and we are 47 (54) persons working at the department (guests not included). More about financial numbers is found in the chapter *Economy*.

Today (2016) the department has 5 full time professors, 1 senior professor, 2 professors emeriti, 1 adjunct professor, 4 associate professors, 1 assistant professor, 4 research engineers, 4 administrators, 4 post-docs and 24 PhD students including 3 industrial PhD students. Some of these numbers include part-time positions. During the year, 6 new PhD students were admitted to the department, 4 of them are engaged in the WASP project. More will follow in the chapter *Staff*.

Five PhD theses by Ola Johnsson, Anders Mannesson, Meike Rönn (Stemann), Fredrik Magnusson and Mahdi Ghazaei, were completed during 2016. The total number of PhDs graduated from the department is now 116.

This year there were three licentiate theses presented by Manfred Dellkrantz, Jonas Dürango and Carolina Lidström.

During 2016, we gave 12 different courses to 1059 students at LTH and 36 students presented their Master's Thesis at the department. We also arranged 8 PhD courses. Read more about this in chapter *Education*.

Education

Education on basic level, PhD studies, Licentiate and Doctoral dissertations

BASIC LEVEL

The engineering education follows the central European system with a five year program leading up to the university degree "civilingenjör" (civ. ing.), with the international title MSc.

Automatic Control courses are taught as part of the engineering curriculum in Engineering Physics (F), Electrical Engineering (E), Computer Engineering (D), Mechanical Engineering (M), Information and Communication Engineering (C), Environmental Engineering (W), Engineering Mathematics (Pi), Industrial Management and Engineering (I), Biotechnology (B), Engineering Nanoscience (N), Chemical Engineering (K) and Biomedical Engineering (BME).

This year, in total 1 059 students were registered out of which 890 completed our courses. 36 students completed their Master's Theses projects, in total 28 theses were presented during 2016. In March this year, we passed

1000 Master's Theses approved at Automatic Control, which was a reason for celebration. A list of the masters' theses is given in the *Appendix "Master's Theses"*.

The number of registered students corresponds to 144 fullyear equivalents during the year.

In the table on the next page, our courses are listed along with the number of students who passed each course. Each course in the engineering program has its own webpage, documentation, manuals, old exams, etc. We also have information sheets about the engineering courses, the Master's Thesis and the doctorate program.

You will find the links at www.control.lth.se/education.



Basic course held at Zhejiang University, Hangzhou – company visit at Akzo.

TOTAL NUMBER OF STUDENTS WHO PASSED OUR COURSES 2016

Reglerteknik FRT010	
(Automatic Control, Basic Course)	475
Realtidssystem FRTN01	
(Real-Time Systems)	60
Olinjär reglering och servosystem FRTN05	
(Nonlinear Control and Servo Systems).....	27
Flervariabel reglering FRTN10	
(Multivariable Control).....	54
Prediktiv reglering FRTN15	
(Predictive Control).....	24
Marknadsstyrda system FRTN20	
(Market Driven Systems)	11
Processreglering FRTN25	
(Process Control)	26
Nätverksdynamik FRTN30	
(Network dynamics).....	27
Systemteknik FRT110	
(Systems Engineering)	51
Reglerteori FRT130	
(Control Theory)	9
Systemidentifiering FRT041	
(System Identification)	8
Projekt i reglerteknik FRT090	
(Projects in Automatic Control).....	33
Matematisk modellering FRT095	
(Mathematical Modeling, Advanced Course)	22
Fysiologiska modeller och beräkningar FRTF01	
(Physiological Models and Computations).....	27
Examensarbete FRT820	
(Master's Thesis Project).....	36

PHD STUDIES

The PhD education consists of four years of studies: 120 hp of courses and 120 hp of thesis work. Since most students also have 20% of department duties, the nominal time for the PhD education is 5 years. In the Swedish system, there is also a possibility to do a half-time thesis called a "licentiate".

In 2016 there were three licentiate theses presented by Manfred Dellkrantz, Jonas Dürango and Carolina Lidström. Five doctoral theses were defended during the year by Ola Johnsson, Anders Mannesson, Meike Rönn (Stemmann), Fredrik Magnusson and Mahdi Ghazaei. We have admitted Tommi Nylander, Alexandre Martins, Per Skarin, Hamed Sadeghi, Martin Heyden and Jacob Mejvik as PhD students, out of which two PhD students and two Industrial PhD students are dedicated to the WASP project.

The following PhD Courses were given in 2016

- *Research Ethics*, Anton Cervin, Charlotta Johnsson, Görel Hedin, Martin Höst
- *Linear Systems*, Michelle Chong, Richard Pates
- *Deep Learning*, Bo Bernhardsson
- *History of Control*, Karl Johan Åström
- *Research Methodology*, Anton Cervin, Charlotta Johnsson, Görel Hedin, Martin Höst
- *Programming Languages and Concepts*, Anton Cervin
- *Control System Synthesis*, Bo Bernhardsson, Karl Johan Åström
- *Stochastic Control*, Björn Wittenmark

LICENTIATE DISSERTATIONS

The licentiate theses, of which the abstracts are presented below, are available in their entirety at www.control.lth.se/publications



Manfred Dellkrantz

Jonas Dürango

Carolina Lidström

MODELING AND CONTROL OF SERVER-BASED SYSTEMS

Dellkrantz, Manfred

When deploying networked computing-based applications, proper resource management of the server-side resources is essential for maintaining quality of service and cost efficiency. The work presented in this thesis is based on six papers, all investigating problems that relate to resource management of server-based systems. Using a queueing system approach we model the performance of a database system being subjected to write-heavy traffic. We then evaluate the model using simulations and validate that it accurately mimics the behavior of a real test bed. In collaboration with Ericsson we model and design a per-request admission control scheme for a Mobile Service Support System (MSS). The model is then validated and the control scheme is evaluated in a test bed. Also, we investigate the feasibility to estimate the state of a server in an MSS using an event-based Extended Kalman Filter. In the brownout paradigm of server resource management, the amount of work required to serve a client is adjusted to compensate for temporary resource shortages. In this thesis we investigate how to perform load balancing over self-adaptive server instances. The load balancing schemes are evaluated in both simulations and test bed experiments. Further, we investigate how to employ delay-compensated feedback control to automatically adjust the amount of resources to deploy to a cloud application in the presence of a large, stochastic delay. The delay-compensated control scheme is evaluated in simulations and the conclusion is that it can be made fast and responsive compared to an industry-standard solution.

CONTROL STRATEGIES FOR IMPROVING CLOUD SERVICE ROBUSTNESS

Dürango, Jonas

This thesis addresses challenges in increasing the robustness of cloud-deployed applications and services to unexpected events and dynamic workloads. Without precautions, hardware failures and unpredictable large traffic variations can quickly degrade the performance of an application due to mismatch between provisioned resources and capacity needs. Similarly, disasters, such as power outages and fire, are unexpected events on larger scale that threatens the integrity of the underlying infrastructure on which an application is deployed.

First, the self-adaptive software concept of brownout is extended to replicated cloud applications.

By monitoring the performance of each application replica, brownout is able to counteract temporary overload situations by reducing the computational complexity of jobs entering the system. To avoid existing load balancers interfering with the brownout functionality, brownout-aware load balancers are introduced. Simulation experiments show that the proposed load balancers outperform existing load balancers in providing a high quality of service to as many end users as possible. Experiments in a testbed environment further show how a replicated brownout-enabled application is able to maintain high performance during overloads as compared to its non-brownout equivalent.

Next, a feedback controller for cloud autoscaling is introduced. Using a novel way of modeling the dynamics of typical cloud application, a mechanism similar to the classical Smith predictor to compensate for delays in reconfiguring resource provisioning is presented. Simulation experiments show that the feedback controller is able to achieve faster control of the response times of a cloud application as compared to a threshold-based controller.

Finally, a solution for handling the trade-off between performance and disaster tolerance for geo-replicated cloud applications is introduced. An automated mechanism for differentiating application traffic and replication traffic, and dynamically managing their bandwidth allocations using an MPC controller is presented and evaluated in simulation. Comparisons with commonly used static approaches reveal that the proposed solution in overload situations provides increased flexibility in managing the trade-off between performance and data consistency.

ON SCALABLE H-INFINITY CONTROL

Lidström, Carolina

Many of the classical approaches to controller synthesis do not scale well for large and complex systems. This is mainly due to computational complexity and the lack of distributed structure in the resulting controllers. It is important that limitations on the information given and processed by sensors and actuators can be incorporated into the design procedure. However, such constraints may greatly complicate controller synthesis. In this thesis, the need for scalability is addressed and a scalable as well as optimal control law is presented. The criteria on optimality is measured in the H-infinity norm, a norm that is fundamental in the theory of robust control and treats the objective of worst-case disturbance attenuation.

The optimal controller is a state feedback law applicable to linear and time-invariant systems with some symmetry in their structure. More specifically, the system has to be stable and have a state-space representation with a symmetric state matrix. Furthermore, the state and control inputs have to be penalized separately. An analog result is given for infinite-dimensional systems. In the infinite-dimensional case, the criteria on the system are essentially as in the finite-dimensional case, however, somewhat more involved.

Systems with the aforementioned property of symmetry have states that affect each other with equal rate coefficients. Such representations appear, for instance, in different types of transportation networks such as buffer systems. The heat equation is an infinite-dimensional system for which the result is applicable. This equation can model heat conduction systems as well as other types of diffusion, such as chemical diffusion. Examples are included to demonstrate the simplicity in synthesis as well as the performance of the control law.

DOCTORAL DISSERTATIONS

The Doctoral theses, of which the abstracts are presented below, are available in their entirety at www.control.lth.se/publications



Ola Johnsson

Anders Mannesson

Meike Rönn (Stemmann)



Fredrik Magnusson

Mahdi Ghazaei

PERTURBATION-BASED CONTROL OF INDUSTRIAL FED-BATCH BIOPROCESSES

Johnsson, Ola

The topic of this thesis is bioprocess control, more specifically control of industrial-scale microbial fed-batch bioprocesses. Its focus is therefore on methods which are easy to implement in an industrial setting, which gives certain limitations on sensors, actuators and control systems.

The main part of the work in the thesis concerns control of the microbial substrate uptake rate by manipulation of the feed rate of liquid substrate to the bioprocess. This is an important parameter for improving process yields, as too low feed rates cause starvation of the microorganisms while too high rates lead to production of undesirable by-products. By-product formation decreases metabolic efficiency and the by-products have inhibiting effects on microbial growth and production. At high concentrations these can even halt growth completely, leading to process failure.

Due to large batch-to-batch variations and the complexity of the processes, model-based control can be difficult to use in this type of system. The approach used in this thesis circumvents this problem

by utilizing perturbations in the feed rate. It has previously been shown that the metabolic state with regard to substrate uptake rate can be determined by analysing the perturbation response in the dissolved oxygen level of a microbial process.

In this thesis, the concept is developed through the use of perturbations at a predefined frequency. This provides a number of advantages and allows for estimation of the metabolic state through observing the perturbation frequency in the measured signal.

The concept has been tested experimentally in industrial pilot and production scale. It has been demonstrated that a controller based on this concept can be used to compensate for batch-to-batch variations in feed demand and can rapidly compensate for changes in the demand. It has also been shown that the method can be used for monitoring and control in bioprocesses with a volume over 100 m³, using a low-complexity estimation algorithm suited for industrial use.

The thesis also concerns mid-ranging control in non-stationary processes. A modified mid-ranging controller suited for such processes is proposed, which allows control signals to increase in unison during the course of a fed-batch process while maintaining the advantages of classical mid-ranging control. The concept can for instance be used for control of dissolved oxygen, an important process parameter in many bioprocesses. It has been successfully used for this purpose in pilot scale alongside the type of perturbationbased feed rate controller which is the main topic of this thesis, also showing how the latter can be used in conjunction with other control systems.

JOINT POSITIONING AND MULTIPATH RADIO CHANNEL ESTIMATION AND PREDICTION

Mannesson, Anders

This thesis investigates the topic of joint positioning and radio channel estimation and prediction. Both positioning and radio channel estimation have a long history of research with many publications but the combination of the two has so far at large been left unexplored. The reason for studying this topic is twofold: improvement of positioning and improvement of radio channel prediction. Positioning is of interest in many situations, such as, e.g., localization in an unknown environment. Better radio channel estimates and prediction enable improved transmission rates with fewer lost data packages in wireless networks. In this thesis, both areas are covered with analysis and simulations and the improvement in positioning performance is also demonstrated with measurements from experiments.

A well established approach for positioning is using an inertial measurement unit (IMU) which contains sensors measuring, e.g., acceleration and angular velocity. Due to noise in the sensors, the dead reckoning performance of the stand-alone unit is quickly degraded. The degradation has previously been combated by fusing the accelerometer and gyroscope signals with other sensor information such as GPS or wheel encoders in order to correct for the errors of the IMU. This is achieved by establishing a model that combines the information from the sensors. In this thesis, such a model is established between the accelerometer and gyroscope readings and the radio channel estimates obtained from pilot signals transmitted in a wireless network. The transfer characteristics of the narrowband radio channel are described with multipath components, where amplitude and angle of arrival are associated with each component. Since it is believed that the performance of the solution is greatly affected by imperfections in the receiver, its frequency error is also included in the modeled.

The joint model is estimated using Bayesian methods, suitable for nonlinear systems. By simultaneously estimating the variables of the multipath components, the frequency error, and the location of the receiver, it is shown that the positioning performance using an IMU, with similar quality found

in a modern day cellular phone, can be greatly improved. Since all the signals needed are present in a typical cellular phone, the proposed solution does not require any extra infrastructure. Both simulations and experiments show that the technique has a potential to give a breakthrough in positioning performance using low-cost inertial measurement units.

With the established model, the variables that describe the future radio channel can also be predicted. By knowing beforehand what signal reception the cellular phone can expect, the transmissions can be adjusted in terms of modulation and transmission power to suit the future channel condition that occurs at the moment when the transmission is received. This is commonly known as link adaptation. Simulations show that the data transmission rates to the end user can be greatly improved in communication systems such as the LTE system.

The thesis also includes an investigation of performance bounds that extends previously known results for the angle of arrival estimation problem and also contributions to joint estimation of angle of arrival and frequency error estimation. These results give an intuitive understanding of how the receiver's trajectory of movement impacts the accuracy achievable when estimating the local radio channel landscape. In mathematical terms this can be stated as that the space-time moments of the trajectory determine the Cramér-Rao lower bound of the variables for joint estimation of angle of arrival and frequency error.

GLYCEMIC CONTROL AND TEMPERATURE CONTROL IN BUILDINGS

Rönn (Stemann), Meike

This thesis consists of two parts, applying concepts from automatic control to different application areas.

The first part of this thesis concerns the development of an optimization-based algorithm, determining the size of insulin and glucose doses for patients suffering from Diabetes Mellitus and treated with multiple insulin injections. Diabetes Mellitus is a chronic disease characterized by elevated blood glucose levels. The therapy usually consists of insulin injections, where the amount of insulin to be administered is decided by the patient using empirically developed rules of thumb. An algorithm is proposed determining the dose intakes of insulin and glucose bringing the blood glucose concentration back to a healthy range. The algorithm uses optimization methods and patient-individual blood glucose predictions to determine these doses. The cost function used for the optimization problem reflects the risk associated with the blood glucose values. A virtual patient was used as an in-silico test-bed for the proposed algorithm. The results were compared to a bolus calculator. It was found that the proposed control algorithm could improve the time of the simulated patient's blood glucose spends in a safe range compared to the bolus calculator.

The second part of this thesis aims at applying inverted decoupling to the area of temperature control in buildings. With inverted decoupling, a multi-variable system can be controlled as several single input single output systems. Buildings are multi-variable systems with many interacting variables. In the second part of this thesis, inverted decoupling is applied to two examples to decrease couplings in the dynamics. For the first example, the aim was to use the decoupling method to decrease interactions of the temperature dynamics of adjacent rooms, in order to be able to regulate the temperature of each room without influence from another room. In the second example, the room temperature was to be regulated using the temperature of the air in a ventilation system. However, changing the air flow rate in the ventilation system influences the room temperature as well. The aim was to use inverted decoupling to decrease this coupling. In simulation studies, the proposed decoupled controller could reduce the effect of the couplings in both examples.

NUMERICAL AND SYMBOLIC METHODS FOR DYNAMIC OPTIMIZATION

Magnusson, Fredrik

Mathematical optimization is becoming increasingly important for engineering in general and control in particular. This thesis deals with numerical methods, primarily direct collocation, and symbolic methods, primarily block-triangular ordering and tearing, for numerical solution of general dynamic optimization problems involving dynamical systems modeled by large-scale differential-algebraic equations (DAE). These methods have been implemented in a software framework in the open-source JModelica.org platform, which is a software tool for simulation- and optimization-based analysis of DAEs described in the modeling language Modelica. The framework relies heavily upon the open-source, third-party software packages CasADi for symbolic operations and algorithmic differentiation and IPOPT for solving the resulting nonconvex optimization problems.

Modelica is a standardized modeling language, which permeates the thesis. One of the many benefits of Modelica is that it is supported by several different tools, allowing implemented models to be used for different purposes. However, Modelica models are often developed for dynamic simulation and sometimes with little regard for numerics, which is enabled by the power of the available simulation software. Consequently, the models may be difficult to reuse for dynamic optimization, which is one of the challenges addressed by this thesis.

The application of direct collocation to DAE-constrained optimization problems is conventionally done by discretizing the full DAE. This often turns out to be inefficient, especially for DAEs originating from Modelica code. The thesis proposes various schemes to symbolically eliminate many of the algebraic variables in a preprocessing step before discretization to improve the efficiency of numerical methods for dynamic optimization, in particular direct collocation. These techniques are inspired by the causalization and tearing techniques often used when solving DAE initial-value problems in the Modelica community. Since sparsity is crucial for some dynamic optimization methods, we also propose a novel approach to preserving sparsity during this procedure.

A collection of five computationally challenging and industrially relevant optimal control problems is presented. The collection is used to evaluate the performance of the methods. We consider both computational time and probability of solving problems in a timely manner. We demonstrate that the proposed methods often are an order of magnitude faster than the standard way of discretizing the full DAE, and that they also increase probability of successful convergence significantly. It is also demonstrated that the methods are beneficial not only for DAEs originating from Modelica code, but also for more conventional textbook DAEs that have been developed specifically for optimization purposes.

ON TRAJECTORY GENERATION FOR ROBOTS

Ghazaei, Mahdi

A fundamental problem in robotics is the generation of motion for a task. How to translate a task to a set of movements is a non-trivial problem. The complexity of the task, the capabilities of the robot, and the desired performance, affect all aspects of the trajectory; the sequence of movements, the path, and the course of motion as a function of time.

This thesis is about trajectory generation and advances the state of the art in several directions. Special attention to trajectories in constrained situations when interaction forces are involved is paid. We bring a control perspective to trajectory generation and propose novel solutions for online trajectory generation with a rapid response to sensor inputs. We formulate and find optimal trajectories

for various problems, closing the gap between path planning and trajectory generation. The inverse problem of finding the control signal corresponding to a desired trajectory is investigated and we extend the applicability of an existing algorithm to a broader class of problems.

To collect human-generated trajectories involving force interactions, we propose a method to join two robotic manipulators to form a haptic interface for task demonstration. Furthermore, fast algorithms for fixed-time point-to-point trajectory generation are investigated. More importantly, two optimal closed-loop trajectory generation methods are proposed. We derive an optimal controller for the fixed-time trajectory-generation problem with a minimum-jerk cost functional. The other method is based on Model Predictive Control, which allows a more generic form of system dynamics and constraints. In addition, a ball-and-finger system is modeled for studying trajectory generation where interaction plays an important role. Efficient movements for rotating the ball are numerically computed and simulated.

Iterative Learning Control (ILC) finds a proper control signal for obtaining a desired trajectory. We derive frequency-domain criteria for the convergence of linear ILC on finite-time intervals that are less restrictive than existing ones in the literature

Research

This chapter contains the different projects that were ongoing during 2016

EXCELLENCE CENTERS

LCCC - LINNÆUS CENTER

Our society is dependent on flexible infrastructure for industrial production, energy supply and communication systems. This requires research and innovations on control of complex systems. Many challenges are common to a wide range of application areas and need to be addressed using a combination of competences from control, communications and computer science.

LCCC is developing theory, methods and tools for control of large-scale engineering systems. Positions for PhD students and postdocs in prioritized areas are combined with short term guest programs of a wider scope. This contributes to creating a highly creative and stimulating environment, that attracts strong applicants at all levels.

LCCC is mainly devoted to fundamental research. The research emphasizes the interaction between theory and applications. Questions addressed could be; How should control equipment across Scandinavia be coordinated to quickly find new routes for electrical power when a transmission line is broken? How should micro-processors in a vehicle gather measurements from several sources and combine engine force with brakes on different wheels to recover

from a dangerous situation? How can multiple applications in a cell-phone be coordinated to make optimal use of battery, memory and processing power?

All these questions are examples of distributed control problems, where several actuators need to cooperate with access to different information and with bounds on the communication between them. The challenge for LCCC is to address such problems and at the same time extend theory and methodology of control beyond the traditional centralized viewpoint. Three directions of fundamental research have been defined to cover the span from mathematical theories to computer tools and implementation. Inspiration comes from application projects, usually with external funding from other sources. See the diagram below:



Three horizontal blocks illustrate the main directions of fundamental research, and six vertical blocks illustrate the application areas. Research is pursued within the vertical and horizontal blocks as well as in the intersections. The research is led by LCCC faculty members, with competence including control, computer engineering and communications.

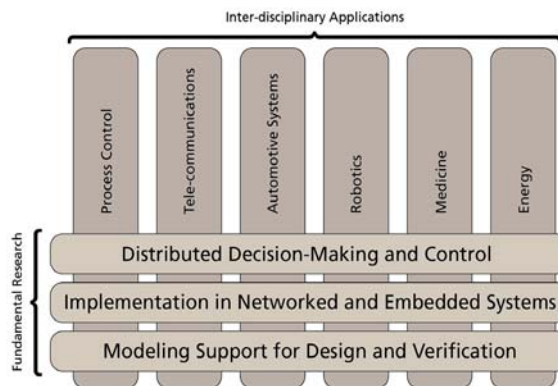

LCCC workshop on Process Control

The Lund Center for Control of Complex systems (LCCC) has hosted a workshop on Process Control, organized by staff from the department, in collaboration with the Process Industrial Centre at Lund University (PICLU). Process control has a long and well-established interest from the research community as well as from industry. The workshop brought together academic and industrial leaders to discuss current and future research directions

and trends within process control. In addition to control and chemical engineering, this includes computer science, industrial IT and automation, and supply chain management. The workshop was held September 28-30, at the Pufendorf Institute in Lund. The workshop consisted in a series of talks by invited world leading academic and industrial experts, and interactive thematic sessions, summarized in a panel discussion.



LCCC Workshop on Process Control in September 2016

ELLIIT - THE LINKÖPING - LUND INITIATIVE ON IT AND MOBILE COMMUNICATION

Researchers: Karl-Erik Årzén, Bo Bernhardsson, Anton Cervin, Anders Rantzer, Anders Mannesson, Martina Maggio, Anders Robertsson, Rolf Johansson, Yang Xu, Josefin Berner, Meike Stemmann, Jacob Bergstedt, Andreas Stolt, Björn Olofsson in collaboration with researchers at the Dept of Computer Science, Electrical and Information Technology, and Mathematics, Lund University, and Linköping University, Halmstad University, and Blekinge University

Funding: VINNOVA/VR (National Strategic Research Area)

ELLIIT is a strategic research environment funded by the Swedish government in 2010, as part of its initiative to support strong research in information technology and mobile communications. ELLIIT has four partners: Linköping University, Lund University, Halmstad University and Blekinge Institute of Technology. ELLIIT constitutes a platform for both fundamental and applied research, and for cross-fertilization between disciplines and between academic researchers and industry experts. ELLIIT stands out by the quality and visibility of its publications, and its ability to attract and retain top talented researchers, and aims at being recognized as a top international research organization.

ELLIIT achieves its goals by a judicious choice of funded focus projects, a structured process for international recruitment, a balanced way of stimulating cooperation between research areas and between the sites involved (LiU, LU, BTH,

HH), and a proactive approach towards fostering and maintaining cooperation with Swedish industry. The overarching objective of ELLIIT is to support scientific excellence in combination with industrial relevance and impact.

The Department of Automatic Control participate in ELLIIT in the following ways:

Karl-Erik Årzén is vice-director for ELLIIT, Director for the Lund part of ELLIIT, and area leader for the Embedded Systems area within ELLIIT. Bo Bernhardsson is an ELLIIT professor.

The Department participate in the following ELLIIT projects:

- Co-Design of Robust and Secure Networked Embedded Control Systems
- Collaborative Robotic Systems
- Local Positioning Systems
- Scalable Optimization for Control Systems
- Online Optimization and Control towards Autonomous Vehicle Maneuvering

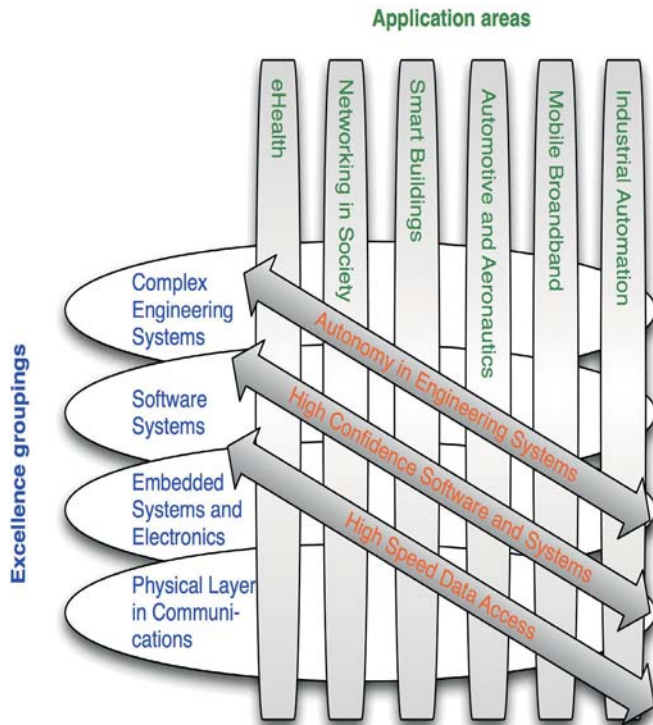

Illustration of the interaction between the themes, the application areas and the groupings (<http://www.liu.se/elliit>)

PIC - PROCESS INDUSTRIAL CENTER

Researchers: Josefin Berner, Tore Hägglund, Charlotta Johnsson, Ola Johnsson, Kristian Soltész in collaboration with Dept of Chemical Engineering, LTH

Funding: SSF



The vision of PICLU is to strengthen an internationally leading centre for research and competence development in process optimization and control. Founded in 2008, PICLU's projects have been jointly financed by over 15 collaborating industry partners, the Swedish Foundation of Strategic Research and VINNOVA. The academic disciplines of Chemical Engineering, Automatic Control and Production Economy form the centre together with several industrial partners from the process industry. The research projects are focused on the three topics; flexibility, controllability and availability.

The research program for Phase 1 and 2 was organized in five integrated projects and focused on the three topics: flexibility, controllability and availability. The projects had a strong interaction both between the projects and with industry partners.

- *Optimal transitions* was a collaboration between the two departments and partner companies Borealis, Siemens and Modelon. Mainly focused on flexibility, it started in 2008. During Phase I, the project studied grade changes at a Polyethylene process at
- *Disturbance management* was a collaboration between the Department of Automatic Control and Perstorp, and the research theme was availability. It started in 2009. During Phase I, the project studied utility disturbances in Perstorp site at Stenungsund. In Phase II, it was focused on local disturbance management in low level control systems.
- *Quality by design and control* was a collaboration between the Department of Chemical Engineering, Novo Nordisk and Pfizer. Started in 2008, its main theme was controllability. The project grew substantially and was therefore divided into two sub projects. Sub project A studied design and control issues while sub project B studied modelling and model calibration.
- *Flexible design* was a collaboration between the Department of Chemical Engineering and K.A. Rasmussen and started in 2010, based on industrial funding. The theme was

Borealis. During Phase 2, it studied model calibration for dynamic models for start-up of power plants at Siemens.

flexibility and this research project included additional experimental resources.

- *Fed-batch control* was a collaboration between the Department of Automatic Control, the Department of Chemical Engineering and Novozymes. The project started in the second half of 2010 and had controllability as its research theme.

PICLU is currently conducting a number of inter-related research projects as part of Phase 3.

- *PiiA-bio* is a three-year project including three stages studying fed-batch steering, steering of cleansing steps, and automation of connected steps. PiiA-bio is financed by VINNOVA and industry partners are Novozymes, Novo Nordisk and Pfizer Health.
- *ProOpt* is a three-year project studying optimization of complex processes, optimization of dynamic processes, and development of optimization tools. The project is financed by VINNOVA and industry partners are Perstorp AB, Novo Nordisk and Modelon.
- *PiiA-Metrics* is a two-year strategic PiiA project mapping key numbers within the process industry and giving implementation advice on their interchangeability in software applications.
- *Automatic tuning* is a project where second generation automatic tuning procedures for PID controllers are developed. A pre-project was financed by PiiA/Vinnova.
- *Smart Mini Factories* is a one-year PiiA project, part of the Smart Industry strategy by the Ministry of Enterprise and Innovation. The project aims to show how industrial digitalization can enable advanced small-scale production of pharmaceuticals. The project is financed by VINNOVA and industry partners are Sobi, Novo Nordisk and Modelon.
- *PiiA pre-projects and PiiA pre-studies* are shorter PiiA projects, less than a year in length, and used to start up research within new work areas. It is financed by VINNOVA. PICLU has performed a number of these shorter projects.

WASP | WALLENBERG AUTONOMOUS SYSTEMS AND SOFTWARE PROGRAM

Researchers: Karl-Erik Årzén, Bo Bernhardsson, Anders Rantzer, Martina Maggio, Per Skarin, Tommi Nylander, Victor Millnert, Alexandre Martins, Hamed Sadeghi

Funding: Knut and Alice Wallenberg Foundation

Wallenberg Autonomous Systems Program (WASP) is Sweden's largest individual research program ever, and provides a platform for academic research and education, fostering interaction with Sweden's leading technology companies. The program addresses research on autonomous systems acting in collaboration with humans, adapting to their environment through sensors, information and knowledge, and forming intelligent systems-of-systems. Software is the main enabler in autonomous systems, and is an integrated research theme of the program. WASP's key values are research excellence and industrial relevance.

The graduate school within WASP is dedicated to provide the skills needed to analyze, develop, and contribute to the interdisciplinary area of autonomous systems and software. The curriculum provides the foundations, perspectives, and state-of-the-art knowledge in the different disciplines taught by leading researchers in the field. Through an ambitious program with research visits, partner universities, and visiting lecturers, the graduate school actively supports forming a strong multi-disciplinary and international professional network between PhD-students, researchers and industry.

The graduate school provides added value on top of the existing PhD programs at the partner universities, providing unique opportunities for students who are dedicated to achieving international research excellence with industrial relevance.

WASP involves five Swedish universities: Chalmers, KTH, Linköping University, Lund University,

and Umeå University together with numerous Swedish industries. At Lund University the following four departments participate: Department of Automatic Control, Department of Computer Science, Department of Electrical and Information Technology, and the Mathematical Imaging Group at the Department of Mathematics.

The program director for WASP is Professor Lars Nielsen, Linköping University and the coordinator for Lund University is Professor Karl-Erik Årzén.

Lund University currently has six university PhD students in WASP plus three industrial PhD students and participates in all six projects. The Department of Automatic Control has two university PhD students and two industrial PhD students and participates in the projects Autonomous Cloud and Localization and Scalability for Distributed Autonomous Systems.

Wallenberg Autonomous Systems Program launches First Research Projects

The Wallenberg Autonomous Systems Program launched six challenging projects, approved at the WASP Board meeting on Tuesday 2015-10-13. Each project is financed with around 3-6 MSEK yearly, with industrial PhD students to be added over the next few months. This initial cluster of projects covers areas that are scientifically important, of high relevance, and which form a broad but well-connected research palette. On the software and computation side, one project will develop methodology for advanced industrial software development, and one project concerns the rapidly emerging area of autonomy in

cloud infrastructures. Two projects consider the key aspect of cooperation between autonomous systems and humans, where one project tackles perception and robotics, and the other deals with new concepts in human-machine interaction such as cognitive digital companions. One project deals with the fundamental questions of localization and scalability, developing new techniques that are expected to be essential in many autonomous systems. The remaining project is aiming at the future automated transport systems.

The projects in summary:

- *Automatic transport systems* – Automated transport systems will revolutionize the efficiency of transportation of people and goods, and at the same time dramatically reduce environmental impact. This project concerns optimization of the overall transport performance by taking advantage of new possibilities for efficient communication, accurate position estimation, and smart decision systems. Coordinated by Professor Bo Wahlberg, KTH Royal Institute of Technology.
- *Autonomous clouds* – This project will provide autonomy and predictability in the distributed cloud by developing dynamic, control-based resource management methods for deciding how much and what type of resources to allocate, and when and where to deploy them. Coordinated by Professor Karl-Erik Årzén, Lund University.
- *Interaction and Communication with Autonomous Agents in Sensor-Rich Environments* – This project will develop the next generation of decision support systems, so called cognitive companions, designed to adaptively reduce the cognitive load caused by the large and rapid information flows while ensuring mission-critical decision timescales. Coordinated by Anders Ynnerman, professor at LiU.
- *Software Engineering for Smart Systems* – Smart and autonomous systems are dependent on software to realize their functionality, but the functionality of these systems must be able to evolve much more rapidly than is possible with classical software engineering approaches. This project will study data-driven methods for continuously evolving the functionality and performance of smart systems. Coordinated by Jan Bosch, professor at Chalmers.
- *Localisation and scalability for Distributed autonomous systems* – Accurate localization – of vehicles, robots, humans, and gadgets in both the absolute and relative sense – is a fundamental component in achieving high levels of autonomy. Scalability is another fundamental component in advanced autonomy. The project will develop technologies which address these objectives with focus on data analytics, learning, control, and distributed optimization. Coordinator: Professor Fredrik Gustafsson, Linköping University.
- *Integrating Perception, Learning and Verification in Interactive Autonomous Systems*. The project will study perception methods based on fusion of multi-modal sensory information in combination with learning, and formal verification of autonomous systems. Danica Kragic is project coordinator and professor at KTH Royal Institute of Technology.

RESEARCH AREAS

The goal of the department is to provide students with a solid theoretical foundation combined with a good engineering ability. This is reflected in the research program which covers both theory and applications. The eight major research areas are:

MODELING AND CONTROL OF COMPLEX SYSTEMS	LARGE SCALE OPTIMIZATION AND CONTROL	CONTROL AND REAL-TIME COMPUTING
PROCESS CONTROL	TOOLS AND SOFTWARE	AUTOMOTIVE SYSTEMS
BIOMEDICAL SYSTEMS		ROBOTICS

RESEARCH WORKING GROUPS AT THE DEPARTMENT

Power networks. *Responsible: Carolina Lidström, Richard Pates*

Traffic control and distributed decision-making. *Responsible: Gustav Nilsson*

Cloud control and Networked Embedded Systems. *Responsible: Karl-Erik Årzén*

Robotics. *Responsible: Rolf Johansson*

Navigation and communication. *Responsible: Bo Bernhardsson*

Process control. *Responsible: Tore Häggglund*

MODELING AND CONTROL OF COMPLEX SYSTEMS

Active Control of Compressor Systems
 Adaptive Control in Flying Vehicles
 ICT platform for sustainable infrastructures
 LISA 2 - Line Information System Architecture 2
 Energy and Building Management
 Collaboration with the European Spallation Source
 Joint Positioning and Radio Channel Estimation
 Stochastic Control Approach of Power System Operation

Theory and computer tools are developed to deal with fundamental complexity issues appearing in many engineering applications, for example aerospace systems, manufacturing and communications

ACTIVE CONTROL OF COMPRESSOR SYSTEMS

Researchers: Rolf Johansson, Anders Robertsson, Alina Andersson in cooperation with Prof. Anton Shiriaev, Umeå University & NTNU, Trondheim and Dr. Leonid Freidovich, Umeå University.

Funding: VR

This project deals with a number of facts related to the output feedback stabilization of the Moore-Greitzer compressor model. We show that quadratic feedback stabilization of the surge subsystem of the three-state Moore-Greitzer compressor model, which ensures an absence of additional equilibria in the augmented with stall dynamics closed loop system, implies convergence of all solutions to the unique equilibrium at

the origin. Then some steps in developing such output feedback controller for surge subsystem are discussed, and a family of controllers is presented. Based on our new theoretical results on integrability, stability, nonlinear dynamic output feedback control, we wish to pursue active control application to compressor systems and experimental verification.

ADAPTIVE CONTROL IN FLYING VEHICLES

Researchers: Anders Pettersson, Rolf Johansson, Anders Robertsson, Karl Johan Åström

Funding: Vinnova

The goal of this project is to address the question whether adaptive control can be used in products that SAAB are developing today or in the future.

There are two fundamentally different ways of controlling systems with dynamics that change over time: adaptive or robust control. The industrial baseline for flying applications

today is to use robust control, which caters for the effect of parametric uncertainties, but this baseline comes with an associated loss of performance. On the other hand, with an adaptive

controller it is possible to boost the performance of the closed-loop system, but then the inherent robustness may be insufficient.



Questions to be addressed:

- Can better performance be achieved for a fully/partly adaptive controller compared to a robust controller, especially with uncertain dynamics in the plant and its subsystems?
- When in a product development cycle, can adaptive steering be used? In what applications can adaptive techniques be used? Subsystems such as actuators perhaps, as well as at the top level?

For the use of adaptive control in these systems, aspects such as product safety, control law clearance and certification should be taken into account.

ICT PLATFORM FOR SUSTAINABLE INFRASTRUCTURES

Researchers: Anders Rantzer, Bo Bernhardsson, Carolina Lidström, Magnus Perninge, Richard Pates, partners at IEA and KTH

Funding: SSF

Resource-efficient infrastructures are critical for sustainable societies that want to maintain and improve today's standard of living. National and international climate goals imply large increases in renewable electricity production. This variable generation together with the increasing inter-

national trading of electricity affects the power flows in the electricity networks, which needs to be managed by system operators on local, regional and national levels. This development is in addition to the continuously increasing demand on reliable electricity supply. Traditionally this

double challenge would be met by the building of new power lines. This is a simple and effective solution, but due to public reluctance to new power lines and the lengthy permission process alternatives are sought for. One general alternative is to use automation for optimizing the use of the available network capacity. This concept - currently referred to as Smart Grids - involves investment in and installation of ICT equipment rather than physical capacity. While having been applied locally before, the situation now calls

for application on a system-wide scale. Similar trends can be observed in other infrastructures.

This project aims to design the decision-layer of an ICT platform for controlling large-scale infrastructures to operate reliably, economically, and with minimum resource waste. Special attention is given to functionality for detecting, clearing and recovering from critical operating conditions. A key component is the ARISTO real-time power system simulator, which will be used as demonstrator to illustrate the results.

LISA2 - LINE INFORMATION SYSTEM ARCHITECTURE 2

Researcher: Charlotta Johnsson incl partners from KTH, Lund University, Chalmers, Scania and Volvo Cars

Funding: Vinnova

The project Line Information System Architecture 2 – Smart event-driven services (LISA2), will deliver industrial-ready services – enabling Swedish industry to understand and tune their factories. Producing the future vehicles in safe and environmentally sustainable way requires handling of an increasing number of data during manufacturing.

This project is a continuation of the VINNOVA-FFI-LISA project. LISA has delivered and validated a modern flexible and scalable event driven architecture able to implement collection and fusion of data from different automatic production sources with a granularity level that stretch down to the single sensor. This provides, in principle, the possibility to mine and parse data across the different layers of manufacturers' ICT

infrastructure, independently from predefined control logic constraints. LISA also preliminary investigated the transformation of data in meaningful information and the relative visualization.

The main purpose of the LISA2 project, is to leverage on the LISA project, and realize a full industrial implementation. LISA2 will produce a set of demonstrators, both in industry and academia, to validate the practical embodiment of the services produced and the knowledge enhancement in the road towards production cyber physical system enabling fast integration, reconfigurability and scalability of automatic production resources. The results are expected to be of very large significance for OEM as well as suppliers in Sweden in respect of efficient as well as appropriate information handling.

ENERGY AND BUILDING MANAGEMENT

Researchers: Josefin Berner, Meike Stemmann, Anders Rantzer

Funding: ELLIIT and LCCC

Buildings account for 40 % of total energy consumption in the European Union, in Sweden one third of the energy used is related to the building sector, and 60% of the energy used in buildings is for heating and ventilation. With a growing building sector, it is necessary to decrease the energy used by heating and ventilation in buildings, so the total energy used in the buildings sector is not increased. Improved control and management of heating and ventilation systems in buildings can help to decrease the energy usage.

This project aims at improving the temperature control in buildings, especially using PID control and Model Predictive Control (MPC). One approach involves automatic tuning of PID controllers (for more details on automatic tuning see Automatic Tuning). To perform well

for temperature control, PID controllers must be tuned correctly, which is often not the case in practice. Automatic tuning can help to overcome this problem. The automatic tuning procedure developed in the project has been tested on an industrial air handling unit with good results.

Another approach is to investigate the temperature interaction between different rooms or zones in a building. Usually, each room would be controlled by a local controller (e.g. On/Off-control or PID). However, the temperature dynamics of adjacent rooms or zones have an influence on each other, which can be significant. To take this interaction into account, the local PID controllers are connected with a decoupling network in order to improve temperature control and occupant comfort.



COLLABORATION WITH THE EUROPEAN SPALLATION SOURCE

Researchers: Bo Bernhardsson, Anders J Johansson (Dept. of Electrical and Information Technology), Rolf Johansson, Olof Troeng, Björn Olofsson

Funding: European Spallation Source

The European Spallation Source will be a major user facility at which researchers from academia and industry will investigate scientific questions using neutron beams.

Neutron methods provide insights about the

molecular building blocks of matter not available by other means. Applications include research in life science, soft condensed matter physics, chemistry of materials, fundamental particle physics and engineering materials.



Control for the Radio-Frequency System

The neutrons are produced by colliding high-speed protons with a rotating tungsten target. The protons are accelerated by oscillating electro-magnetic fields in 155 radio-frequency cavities along the 482 meter long linear accelerator.

In order to avoid defocusing of the beam (which leads to activation of the accelerator structure), it is crucial that the amplitudes and phases of the cavities are kept close to their nominal values. This requires both high-performance feedback loops and a very stable phase reference.

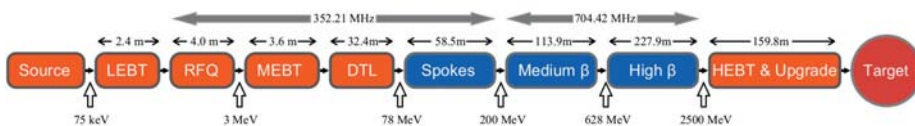

Cavity Field Control

In order to achieve regulation of the cavity fields sufficiently close to the reference values, feedback loops with sampling frequencies of 10 MHz will be used. The Department of Automatic Control is involved in system modeling and controller design for these loops as well as supporting the development of requirements on RF system components. The work is coordinated by this group at the Department of Electrical and Information Technology.

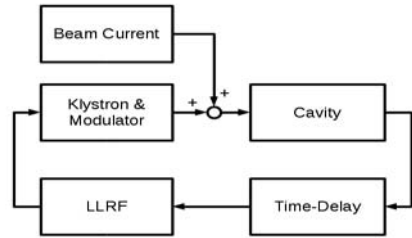

Temperature Control of Phase-Reference Line

In order to distribute the reference phase from the master oscillator to the beam position monitors and the 155 cavity field control loops with sufficiently small drift requires that the more than 500 meters long phase distribution line is temperature stabilized to less than a tenth of a degree.

The Dept. of Automatic Control at Lund University is involved in the design and development of the temperature control system for the phase distribution line. The research performed includes modeling and simulation of the control system as well as experimental evaluations on a prototype of the phase-reference distribution system.

Compensation of Lorenz-Force Detuning

The high strengths of the electro-magnetic fields in the super conducting cavities leads to mecha-

nical deformation cavity wall, which changes their fundamental resonance frequency. This leads to reduced efficiency and makes the RF field control problem harder. The Department of Automatic Control will together with collaborating European universities design the control algorithm for the piezo-electric compensation system that will be used to counter-act the Lorenz force detuning. The work is coordinated by this group at the Department of Electrical and Information Technology.

OTHER INVESTIGATIONS

Simulations of Cryogenic Distribution Line at ESS

The cryogenic system at ESS has been modeled in Dymola. Simulations have been made of the cool-down and warm-up of the superconducting section of the linear accelerator. Also the required capacity of the helium safety discharge system has been investigated.



JOINT POSITIONING AND RADIO CHANNEL ESTIMATION

Researchers: Bo Bernhardsson, Anders Mannesson

Funding: VR

The project works with algorithms to combine information from gyros, accelerometers and compass sensors with radio channel estimation and to determine the fundamental properties of such schemes. The hope is to enable two technology advancements:

- a new method for significantly reduced drift in low cost navigation systems
- improved radio channel estimation for moving terminals, suitable for MIMO systems

Initial research show promising result as presented in the licentiate thesis by Anders Mannesson.

The work is based on angle of arrival estima-

tion using antenna arrays which is a well studied problem with many different algorithms resolving the individual rays impinging on the array. However, less attention has been given to so called virtual array antennas where moving receiver elements are used. By tracking the movement of the element, an array with properties similar to a stationary array with multiple elements is formed. By combining the IMU and the radio channel information, a map of the local radio environment can be obtained, such as in this picture illustrating the complex valued radio channel for three impinging planar radiowaves in a noise-free situation (see picture below)

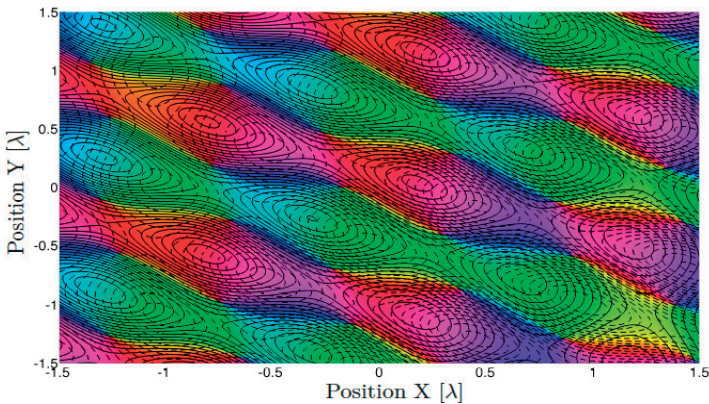

Tightly coupled nonlinear state estimation algorithms between IMU signals and radio channel estimates are used to simultaneously estimate this map and obtain improved pose estimates.

The major challenge is to battle the drift in sensors and radio crystal oscillators. We work with both real-world measurements and simulations to evaluate performance. Initial experi-

ments show promising results. The following figure shows performance (simulations left, real experiments right) with realistic radio and IMU imperfections. There is a dramatic improvement by including radio channel information compared to using dead reckoning, especially for movements longer than 10 seconds

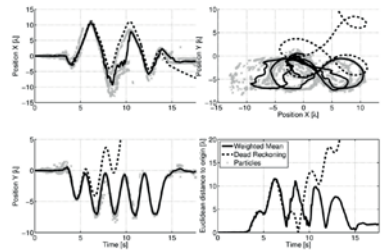
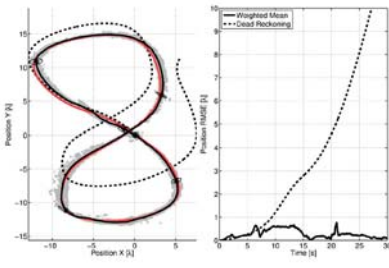

Our future research now focuses on improving radio channel estimation and prediction by adding IMU information and using motion models.

STOCHASTIC CONTROL APPROACH OF POWER SYSTEM OPERATION

Researchers: Magnus Perninge

Funding: VR

One of the main challenges when operating a power system is the economic re-dispatch performed to meet the continuously changing consumption patterns. When assuming the market structure of most deregulated power markets, with a specific power market designated to re-dispatch, the re-dispatch problem becomes an optimal switching problem with delays.

This aim of this project is therefore devoted to numerical solution techniques for large-scale stochastic optimal switching problems with delays.

Stochastic optimal switching problems are a subset of stochastic optimal control problems

where the control set is finite and there is a fixed cost (or reward) associated to switching between the different points of the control set.

Stochastic optimal switching has a number of other important applications, such as mineral extraction, electricity generation optimization, gas storage, traffic control, etc. Almost all of which have switching delays.

Although the stochastic optimal switching problem has been solved in a rather general setting, most numerical methods suffer from the curse of dimensionality (which becomes even more apparent in the presence of delays).

DK1	41 489	35 428
DK2	17 851	22 317
DK	59 260	57 745
SE1	34 317	12 483
SE2	85 331	17 941
SE3	105 228	104 950
SE4	11 788	31 220
SE	217 661	104 327
FI	124 975	151 878
EE	19 352	15 558



LARGE SCALE OPTIMIZATION AND CONTROL

Distributed Control and Verification
 Large scale Convex Optimization
 Low-rank approximation with convex constraints
 Dynamic Exchange Economics in Transport Systems
 Control Using Distributed Information
 Numerical and Symbolic Algorithms for Dynamic Optimization

One of the greatest challenges of modern engineering is the sustainable and safe operation of large-scale technical systems. To address this challenge, we need to develop scalable methods for control and optimization.

DISTRIBUTED CONTROL AND VERIFICATION

Researchers: Carolina Lidström, Michelle Chong, Giulia Giordano, Richard Pates, Kaoru Yamamoto, Anders Rantzer

Funding: VR

Most of control theory has been developed in a centralized setting, where all measurements are processed together to compute the control signals. This paradigm has conceptual advantages, but also inherent limitations. In contrast, industrial practice often relies on distributed control structures. Hence, there is a strong need for theory and methodology supporting design and verification of distributed controllers. The purpose of this research project is to address this need along three main directions:

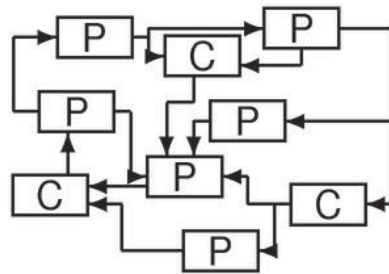

- **Monotone systems.** Many large scale control applications exhibit natural monotonicity properties, which can be exploited for scalable analysis and control synthesis.
- **Structured H-infinity optimal control.** Non-uniqueness of H-infinity optimal controllers is exploited for derivation of distributed control structures.
- **Scalable Integral Quadratic Constraints.** We are exploring scalable versions of classical analysis methods for feedback systems. Driving applications range from neuro-science to structural engineering and stochastic optimization.

LARGE SCALE CONVEX OPTIMIZATION

Researchers: Pontus Giselsson, Mattias Fält

Funding: SSF

Large-scale convex optimization problems appear naturally in many engineering fields such as machine learning, signal processing, image reconstruction, control, and bioinformatics. Many efficient algorithms exist that are specialized for a particular problem formulation. In this project, we are developing and analysing general

purpose algorithms that can solve essentially any large-scale convex optimization problem. We are focusing on algorithm development, theoretical algorithm analysis, as well as creation of software packages for user-friendly access to the developed methods.

LOW-RANK APPROXIMATION WITH CONVEX CONSTRAINTS

Researchers: Christian Grussler, Anders Rantzer, Pontus Giselsson, Andrey Ghulchak

Funding: LCCC Linnaeus center

Model Order Reduction of Postive Systems:

Transportation networks, biological systems as well as heat transfer model are only a few examples for systems with the fundamental property of operating with positively measured inputs and outputs only. Typically these systems are large-scale and one way of overcoming this issue in control and simulations is to approximate the systems with the help of so-called Model Order Redcution (MOR). Unfortuantely, stanard MOR-methods do not preserve positivity and by that may lead to false conclusions in simulations as well as controler design.

Research in Posivity Preserving Model Order Reduction has been conducted earlier, however with strong conservatism regarding dimensionality and errors. Our main goal is to supply new approximatoin strategies with the incentive of

weakening the current conservatism, e.g. by considering ellispoidal cone invariant systems.

Low-rank approximation with convex constraints

Model order reduction that is preserving external positivity is essentially equivalent to a low-rank approximation of an infinite-dimensional Hankel-matrix under the preservation of the Hankel-structure and the non-negativity. However, even for finite matrices it is unkown how to find an optimal low-rank approximation that preserves convex constraints. Instead heuristics, like the nuclear-norm regularization method are the state of the art.

Our main goal is to fill this gap and give deterministic solutions that do not depend on a regularization parameter.

DYNAMIC EXCHANGE ECONOMICS IN TRANSPORT SYSTEMS

Researchers: Martin Heyden, Anders Rantzer

Funding: SSF

We study the interplay between economics and traffic flows in transport networks. Such competitive interaction is essential in many applications, including logistics, electrical power flow and telecommunications. Our objective is to understand and exploit the interaction between

node demands and network dynamics with focus on:

- Exchange equilibria in traffic networks.
- Network dynamics in presence human decision-makers

This is a subproject of SoPhy.

CONTROL USING DISTRIBUTED INFORMATION

Researchers: Hamed Sadeghi, Anders Rantzer

Funding: Knut and Alice Wallenberg Foundation

Motivated by applications in infrastructure networks (mainly traffic and transportation) we are studying how network flows can be optimized using distributed controllers. Existing results for linear systems with an H-infinity objective will be generalized to accommodate non-linear flow constraints and other convex objectives. Goals:

- Scalable methodology for control of network flow control
- Stable and robust systems optimal performance
- Apply methods to traffic/transportation systems

The project is a subproject of WASP

NUMERICAL AND SYMBOLIC ALGORITHMS FOR DYNAMIC OPTIMIZATION

Researchers: Fredrik Magnusson, Johan Åkesson (Modelon), Christian Andersson (Numerical Analysis)

The target of this project is the development of algorithms for numerical solution of large-scale, DAE-constrained, non-convex dynamic optimization problems. The project targets both optimal control and parameter estimation as well as other forms of dynamic optimization. Applications include minimization of material and energy consumption during set-point transitions in power plants and chemical processes, minimizing lap times for vehicle systems, trajectory optimization in robotics and identifying unknown parameter values of models using measurement data.

The first step of the project has been to implement state-of-the-art algorithms based on collocation methods and integrate them with the high-level, object-oriented modelling language Modelica and its extension Optimica. This allows basic users to conveniently formulate and solve problems of moderate difficulty without worrying about the details of the solution algorithms, while still allowing advanced users to tailor the algorithm as needed for complex problems. This implementation is a part of the open-source JModelica.org project. Two important third-party tools used within the project is CasADi,

for automatic differentiation, and IPOPT, for solution of non-linear programs.

The current research direction is to symbolically process the differential-algebraic equation system describing the dynamics to create a block triangular structure of the incidence matrix by employing graph algorithms, as illustrated below. This structure facilitates analytic solution of many of the algebraic equations, removing the need to expose these to the numerical op-

timization algorithm. This drastically reduces the number of optimization variables, and may also result in a better conditioned problem, thus potentially improving both convergence speed and robustness of iterative solvers.

The applicability of the algorithms are explored in other application-oriented research projects, in collaboration with other research groups from both academia and industry.

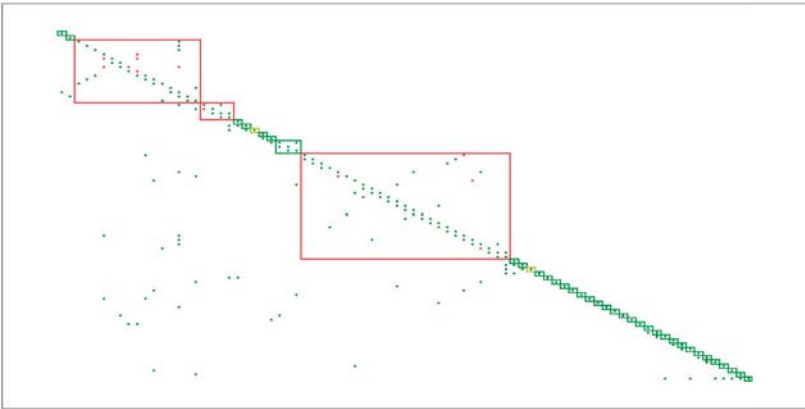

CONTROL AND REAL-TIME COMPUTING

Event-Based Estimation and Control
 Co-Design of Robust and Secure Networked Embedded Control Systems
 LUCAS - Lund Center for Applied Software Research
 Cloud Control
 Power and temperature control for large-scale computing infrastructures
 Feedback Computing in Cyber-Physical Systems
 Autonomous Cloud

In the Control and Real-Time Computing area we work in two main directions:

- Implementation of control systems on resource-constrained implementation platforms, e.g., small embedded processors or networked controllers with limited communication bandwidth. This also includes event-based control.
- Applications of control to computing and communication systems. This includes control of server systems and adaptive resource management of embedded systems.

EVENT-BASED ESTIMATION AND CONTROL

Researchers: Marcus Thelander Andrén, Anton Cervin, Bo Bernhardsson, Kristian Soltész

Funding: VR

The vast majority of all feedback controllers today are implemented using digital computers, relying on periodic sampling, computation, and actuation. For linear systems, sampled-data control theory provides powerful tools for direct digital design, while implementations of nonlinear control designs tend to rely on discretization combined with fast periodic sampling. In recent years, there has been a growing research interest in event-based control, in particular in connection to distributed and networked control systems. The basic idea is to communicate, compute, or control only when something significant has occurred in the system. The motivation for abandoning the time-triggered paradigm is to better cope with various constraints or bott-

lenecks in the system, such as sensors with limited resolution, limited communication or computation bandwidth, energy constraints, or constraints on the number of actuations.

During 2016 we have investigated stochastic event-triggered sampling. Using a specific stochastic triggering rule in the sensor node simplifies the estimation rule in the controller, allowing a standard time-varying Kalman filter to be used. We have also developed a simple benchmark for event-based control that is based on LQG-optimal PI(D) control. Using Monte Carlo simulations, the benchmark can be used to compare the performance of continuous-time, sampled-data and various event-based control strategies.

CO-DESIGN OF ROBUST AND SECURE NETWORKED EMBEDDED CONTROL SYSTEMS

Researchers: Yang Xu, Anton Cervin, and Karl-Erik Årzén, in collaboration with the Embedded Systems Lab at Linköping University

Funding: ELLIIT

Modern embedded control systems comprise periodic and sporadic software tasks that control several physical processes and execute on platforms with multiple computation and communication components. The project focuses on the complex system timing induced by resource sharing among the tasks, which is one of the main characterizations of the control quality. This control quality, which is affected negatively by long and varying computation and communication delays in the control loop, will be considered during system-level scheduling and optimization, as well as during controller synthesis by delay-compensation techniques.

Many control systems have time-varying resource demands, implying that scheduling policies and control strategies must be adapted at runtime to provide high control quality and efficient resource usage. Such variations are inherent in event-based control, which is an emerging technology in resource-constrained systems, but also occur depending on the sta-

tes of the controlled processes or as a result of process disturbances and mode changes. The project will therefore also consider runtime optimization techniques to address such variations.

The project aims to push the state of the art of integrated control and computer systems design in several directions. We shall develop design methods for control-quality optimization of embedded control applications running on distributed execution platforms, which, for example, are very common in the automotive systems domain. Our subsequent aim is to develop design-time and runtime optimization methods that trade off control quality with the varying resource requirements present in multi-mode and event-based control systems. The long-term objective of the project is to develop an optimization and resource-management framework to be used for the design and implementation of future resource-constrained and adaptive embedded control systems.

LUCAS - LUND CENTER FOR APPLIED SOFTWARE RESEARCH

Researchers: Karl-Erik Årzén, Rolf Johansson, Anders Robertsson, Anton Cervin, Martina Maggio, Anders Blomdell, in collaboration with Dept of Computer Science, Lund University

The Center for Applied Software Research (LUCAS) is a collaboration between the software-oriented parts of the Departments of Automatic Control and Computer Science at LTH. In total around 15 faculty members and 20 PhD students are involved in LUCAS. The focus of LUCAS is industrially-oriented and motivated software research. This includes research on software

engineering, software technology, and software applications. Special focus is put on real-time systems, in particular embedded systems, networked systems, and control systems.

LUCAS started in 1999 and its status has changed over the years. Currently its main role is to act as an umbrella organization. The main activity is the annual LUCAS workshop.

CLOUD CONTROL

Researchers: Karl-Erik Årzén, Anders Robertsson, Anton Cervin, Anders Rantzer, Martina Maggio, Jonas Dürango, Manfred Dellkrantz, in collaboration with Maria Kihl's group at the Dept of Electrical and Information Technology, Lund University and Erik Elmroth's group at Umeå University

Funding: VR

We take a control theoretic approach to a range of cloud management problems, aiming to transform today's static and energy consuming cloud data centers into self-managed, dynamic, and dependable infrastructures, constantly delivering expected quality of service with acceptable operation costs and carbon footprint for large-scale services with varying capacity demands. Such data centers will form the backbone of the digitalized society by providing unparalleled information storage and processing capabilities.

Today's explosive growth of the Internet and mobile connectivity hints at a digitized society where information is created, stored, processed, and distributed at a previously unparalleled rate, already today including, e.g., multimedia services as online TV and music, social networks, scientific applications, and business services such as e-commerce, online banking, enterprise applications, etc. Whereas the Internet is becoming ubiquitous and provides reasonably mature communication abilities, significant advancements are required to create the future cloud data centers that will form a backbone for information processing and storage, and thus be a key enabler of the digitized society.

However, with a continued extreme growth in capacity demands, today's cloud data center infrastructures are literally jeopardizing the continued development of the digitized society by simply being too static, providing too low Quality-of-Service (QoS), and by consuming ridiculous amounts of energy. Today's data center infrastructures are not even near being able to cope with the enormous and rapidly varying capacity demands that will be reality in a near

future. So far, very little is understood about how to transform today's data centers (being large, power-hungry facilities, and operated through heroic efforts by numerous administrators) into a self-managed, dynamic, and dependable infrastructure, constantly delivering expected QoS with reasonable operation costs and acceptable carbon footprint for large-scale services with sometimes dramatic variations in capacity demands.

To meet these challenges, the project addresses a set of fundamental and inter-twined auto-management challenges assuming that there during execution are stochastic variations in capacity needs and resource availability, as well as changes in system response and operation costs (in monetary and energy terms). The challenges include how much capacity to allocate at any time for an elastic application, where to allocate that capacity including optimizing complete data center energy efficiency, if to admit an elastic service with unknown lifetime and future capacity demands, as well as how holistic management can be performed to optimize the various management tools' concerted actions.

This cross-disciplinary project builds on a collaboration between Umeå University and Lund University with complementing expertise on cloud management and control of computing systems. The collaboration addresses fundamental algorithmic challenges that in industrial collaborations have been identified as crucial.

The project is funded by a 20 million SEK framework grant from the Swedish research council (VR).

POWER AND TEMPERATURE CONTROL FOR LARGE-SCALE COMPUTING INFRASTRUCTURES

Researcher: Martina Maggio

Funding: VR

Modern computing systems are constrained by dark silicon, the abundance of transistors enables processors to draw more power than they can safely sustain. For example, the Exynos 5 processor (in the Samsung Galaxy S4 phone) has a 5.5W peak power that is nearly twice the maximum sustainable heat dissipation, limiting peak speed to less than 1 second. At the other end of the spectrum, the next generation of exascale supercomputers is predicted to be constrained by an operating budget of approximately 20 MW. In addition, Microsoft was recently fined for not using enough power and violating an agreement with a utility company. Executing efficient code in these systems requires solving a constrained optimization problem: maintaining the power budget, while maximizing performance within the power constraint.

Many separate components contribute to total power consumption and various techniques have been proposed to manage individual components. For example, management systems exist for CPU allocation, dynamic voltage and frequency scaling, processor idling, cache, DRAM, and disk. However, the coordination of these many actuators is non-trivial and requires knowledge on all the potential nonlinearities that the hardware infrastructure may expose. The goal of this research is to develop a platform-independent resource manager to control the temperature and power consumption of large computing infrastructures like data centers. This management system should be general with respect to the running platform and must address three challenges:

- **Unknowns:** prior research approaches rely on rigorous models for either the specific machine under control or for a specific application and platform. A generalized power

management system, however, must either construct its models on the fly or compensate for inaccuracies and unknowns in the model.

- **Interaction:** System components interact to produce a complex (often nonlinear) effect on power, temperature and performance. If individual components are controlled separately, their interaction can lead to sub-optimal behavior, even when these separate controllers are individually optimal. Thus, a generalized power management system must coordinate all available components even if they are not known at design time or vary at runtime.
- **Optimization:** A power manager must not exceed the power budget, yet must also deliver the best possible performance for a given budget. A generalized approach must not sacrifice too much performance for generality.

This research addresses the above challenges, the result so far has been a machine-level power management system that is general with respect to the components it manages, and uses feedback control to ensure that the power and temperature budget are respected, while delivering the best possible performance to the running applications. The project originated by a publication at PACT 2013 (Parallel Architectures and Compilation Techniques) entitled "ThermOS: System Support for Dynamic Thermal Management of Chip Multi-Processors". It has led in 2014 to the publication of the article "PCP: A Generalized Approach to Optimizing Performance Under Power Constraints through Resource Management" at ICAC 2014 (International Conference on Autonomic Computing). The follow up on this research has been presented at RTAS

2015 (21st IEEE Real-Time and Embedded Technology and Applications Symposium) with the paper POET: a portable approach to minimizing energy under soft real-time constraints and at

FSE 2015 (Foundations on Software Engineering) with the paper Automated multi-objective control for self-adaptive software design.

FEEDBACK COMPUTING IN CYBER-PHYSICAL SYSTEMS

Researchers: Karl-Erik Årzén (project leader), Johan Eker, Martina Maggio, Victor Millnert, Gautham Nayak Seetanadi in collaboration with Jörn Janneck and PhD students at Dept of Computer Science, LTH and with Enrico Bini at Scuola Superiore Sant'Anna in Pisa, Italy

Funding: VR Framework Grant

Cyber-Physical Systems (CPS) have emerged as a unifying concept for systems whose computational aspects are tightly integrated with the physical world. CPSs have often a strong focus on resource-efficiency, i.e., power efficiency and thermal constraints are important. The close interaction with the physical environment and humans also lead to a high level of uncertainty, i.e. it is difficult to specify how the system will be used, what the requirements are, and what the load will be. This has consequences for the computational parts of CPS. Static designs are unrealistic. Instead, the systems must dynamically react to changing conditions. They need to take action based on on-line measurements of performance, resource consumption etc., i.e., they must be based on feedback.

The objective is to develop a unified approach to feedback computing that covers: embedded

systems, massively parallel manycores, desktop systems, and distributed systems. The aim of the control is either to improve performance, e.g., reduce latency or increase throughput, or to reduce resource consumption. The project emphasizes the development of generic techniques that can be employed within several or all of the four areas above.

The project is divide into three parts:

- Feedback computing for the distributed cloud (Johan Eker, Victor Millnert, Enrico Bini)
- Feedback computing for distributed camera systems (Martina Maggio, Gautham Nayak Seetanadi, Karl-Erik Årzén)
- Feedback Computing for manycores (Jörn Janneck)

WASP: AUTONOMOUS CLOUD

Researchers: Karl-Erik Årzén, Martina Maggio, Johan Eker, Tommi Nylander, Per Skarin, Alexandre Martins in collaboration with Maria Kihl at the Dept of Electrical and Information Technology, with Erik Elmroth, Cristian Klein, and Chanh Nguyen at Umeå University, and with Amir Roozbeh and Dejan Kostic at KTH.

Funding: Knut and Alice Wallenberg Foundation through WASP (Wallenberg Autonomous Systems Program)

Background

An increasing amount of computing and information services are moving to the cloud, where they execute on virtualized hardware in private or public data centers. Hence, the cloud can be viewed as an underlying computing infrastructure for all systems of systems. The architectural complexity of the cloud is rapidly increasing. Modern data centers consist of tens of thousands of components, e.g., compute servers, storage servers, cache servers, routers, PDUs, UPSs, and air-conditioning units, with configuration and tuning parameters numbering in the hundreds of thousands. The same increasing trend holds for the operational complexity. The individual components are themselves increasingly difficult to maintain and operate. The strong connection between the components furthermore makes it necessary to tune the entire system, which is complicated by the fact that in many cases the behaviors, execution contexts, and interactions are not known a priori. The term autonomous computing or autonomic computing was coined by IBM in the beginning of the 2000s for self-managing computing systems with the focus on private enterprise IT systems. However, this approach is even more relevant for the cloud. The motivation is the current levels of scale, complexity, and dynamicity which make

efficient human management infeasible. In the autonomous cloud control, AI, and machine learning/analytics techniques will be used to dynamically determine how applications should be best mapped onto the server network, how capacity should be automatically scaled when the load or the available resources vary, and how load should be balanced.

Currently there is also a growing interest in applying cloud techniques, such as virtualization and collocation, in the access telecommunication network itself. The unification of the telecom access network and the traditional cloud data centers, sometimes referred to as the distributed cloud, provide a single distributed computing platform. Here the boundary between the network and the data centers disappears, allowing application software to be dynamically deployed in all types of nodes, e.g., in base stations near end-users, in remote large-scale datacenters, or anywhere in between. In these systems the need for autonomous operation and resource management becomes even more urgent as heterogeneity increases, when some of the nodes may be mobile with varying availability, and when new 5G-based mission-critical applications with harder requirements on latency, uptime, and availability are migrated to the cloud.

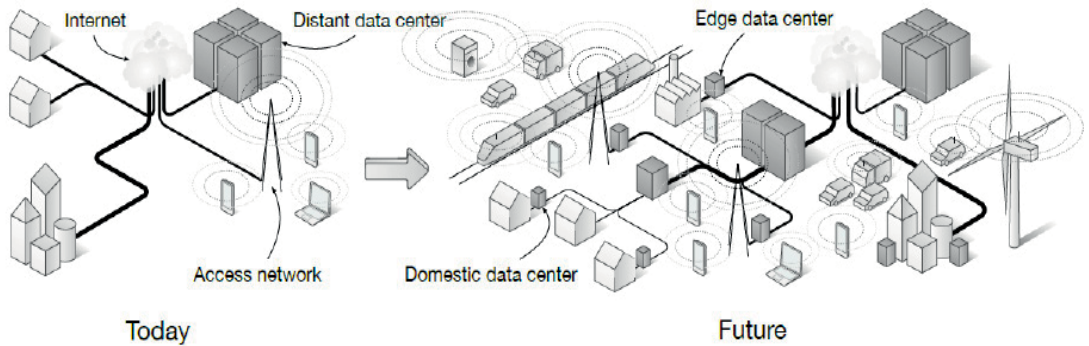

The above figure illustrates how the computations in the distributed cloud are migrating from back-end data centers out in the network.

Project Outline

In the project distributed control and real-time analytics will be used to dynamically solve resource management problems in the distributed cloud. The management problem consists of deciding the types and quantities of resources that should be allocated to each application, and when and where to deploy them. This also includes dynamic decisions such as automatic scaling of the resource amount when the load or the available resources vary, and on-line migration of application components between nodes. Major scientific challenges include dynamic modeling of cloud infrastructure resources and workloads, how to best integrate real-time analytics techniques with model-based feedback mechanisms, scalable distributed control approaches for these types of applications and scalability aspects of distributed computing.

In order to develop efficient methods for resource management, it is crucial to understand the performance aspects of the infrastructure, what the workloads look like, and how they vary over time. Hence, Infrastructure modeling and Workload modeling for the distributed cloud are important topics. Due to user mobility and variations in usage and resource availability, applications using many instances are constantly

subject to changes in the number of instances; the individual instances relocated or resized; the network capacity adjusted; etc. Capacity autoscaling is needed to determine how much capacity should be allocated for a complete application or any specific part of it; Dynamic component mapping to determine when, where, and how instances should be relocated, e.g., from a data center to a specific base station; and Optimized load mix management to determine how to “pack” different instances on individual servers or clusters. Since not all applications are equally important, e.g., due to differently priced service levels or due to some being critical to society (emergency, health care, etc.), the solutions to the three problems above must take into account Quality of Service differentiation. Finally, we address Holistic management to perform full-system coordination.

The primary software infrastructure will be based on Calvin, an open source application environment developed by Ericsson and aimed at distributed clouds for IoT services. Calvin is based upon on the well-established actor model, it scales well, and it supports live migration of application components. We believe this infrastructure is suitable to investigate the application performance behavior of future

commercial systems and validate our developed management solutions. It will enable accurate estimations of, for example, application latency and system loads.

The project results have the potential to be demonstrated in several WASP demonstrator arenas, including the Autonomous Research Arena (ARA), the Ericsson Research Data Center (ERDC); as well as in different university lab facilities.

Industrial PhD Projects

The project contains three industrial PhD student projects.

These are:

- *Autonomous network resource management in disaggregated data centers* - PhD student: Amir Roozbeh, Ericsson Research; Academic Supervisor: Dejan Kostic, KTH; Industrial Supervisor: Fethai Wuhib, Ericsson
- *Autonomous learning camera systems in resource constrained environments* - PhD student: Alexandre Martins, Axis; Academic Supervisor: Karl-Erik Årzén; Industrial Supervisor: Mikael Lindberg, Axis.
- *Mission-Critical Cloud* - PhD student: Per Skarin, Ericsson Research; Academic Supervisor: Karl-Erik Årzén; Industrial Supervisor: Johan Eker, Ericsson.

PROCESS CONTROL

PICLU
PIC-opic
PID Control
Automatic Tuning
Decentralized Control Structures
Optimizing fermentation control for *B. licheniformis*
PiiA-Metrics
Dig-PI
Sysint4.x

The department has always had an active collaboration with the process industry as well as with the suppliers of process control instrumentation and systems. Most of the research projects are formed together with the process industry, and several of them are performed with active participation by staff from industry. Many of the research results are also transferred to instrument and system suppliers, and implemented and used in process industry.

PROCESS INDUSTRIAL CENTRE AT LUND UNIVERSITY

Researchers: Josefin Berner, Tore Hägglund, Charlotta Johnsson, Ola Johnsson, Kristian Soltesz

Funding: SSF

With support from the Swedish Foundation for Strategic Research (SSF), the process industrial centre PIC-LU was established in collaboration with the department of Chemical Engineering.

The overall goal of PIC-LU is to establish, in cooperation with Swedish process industry, an internationally leading centre for research and professional training in process optimization and control.

In the research program, methodology and tools for modelling, optimization, and control of industrial processes are developed, in order to improve production systems with respect to flexibility, controllability, and availability. The methodology and the tools are developed from

specific solutions to process control problems suggested by the industrial partners. The goal is to make the results from PIC-LU industrially relevant, not only for the participating industries, but on a wide scale in process operation and automation.

In the competence development program, the main goal is to increase the competence level of process optimization and control in industry as well as in academy. The goal will be reached in two ways; through an educational program at different levels for staff in process industry, and by directed efforts in MSc and PhD programs at the university.

PROCESS INDUSTRIAL CENTRE – OPTIMIZATION, PERFORMANCE, INTEGRATION AND CONTROL (PIC-OPIC)

Researchers: Charlotta Johnsson and Tore Hägglund in cooperation with researchers from Dept of Chemical Engineering at Lund University as well as researchers at Linköping University

Funding: SSF

With support from the Swedish Foundation for Strategic Research (SSF), the PIC-opic project was established in 2012 in order to strengthen the integration between the various hierarchical control level found in companies today. Generally, the lower levels of the automation hierarchy are focused on operational decisions and thereby close to the real production and real time control and measurements, whereas the higher levels are closer to strategic decisions and thereby closer to economical performance evaluations.

PIC-opic is a joint research between Lund University and Linköping University. It consists of three (3) subprojects with the aim of integrating different levels in the hierarchy. Subproject A focuses on buffer management and inventories, subproject B focuses on key performance indicators and subproject C focuses on economical optimization. The three projects all incorporate knowledge and personnel from the two research centres PIC-LI and PIC-LU.

PID CONTROL

Researchers: Karl Johan Åström, Josefin Berner, Tore Hägglund and Kristian Soltész

This project has been in progress since the beginning of the eighties, and resulted in industrial products as well as several PhD theses. Three monographs on PID control that are based on experiences obtained in the project have also been published. The last is "Advanced PID Control", published in 2005. It is also translated to Spanish 2009: "Control PID avanzado". The research is currently focused on the following topics:

Software tools for design of PID controllers

A Matlab-based software tool for optimal PID design has been developed at the department. The software finds the PI or PID controller that minimizes the Integrated Absolute Error (IAE) value during a step load disturbance on the process input, with respect to robustness constraints on the sensitivity and complementary sensitivity functions. This PID design method is called SoftWare-based Optimal Robust Design (SWORD).

Varying the time constant of the low-pass filter, it is possible to find optimal or near-optimal solutions to an optimization problem extended

with a noise sensitivity constraint. As the time constant of the low-pass filter increases, the PID controller will gradually transform into a PI controller and then finally an I controller. This gives a natural set of I, PI and PID controllers to choose from. The final controller can be selected based on visual feedback of the control signal activity due to measurement noise.

The optimal solutions to the extended optimization problem can also be used to compare the performance of PI and PID controllers to examine the benefit of the derivative part for different processes. Assuming continuous time white Gaussian noise with unit spectral density, it is possible to derive optimal PI and PID controllers

with the same robustness and noise sensitivity constraints. The ratio of optimal PI performance divided by optimal PID performance for the case of medium noise sensitivity and high robustness is plotted in the figure. Each symbol represents a process in a batch of 134 models representative for the process industry. These have been classified with respect to their normalized time delay, τ . Processes with τ close to zero or one generally benefit less from the derivative part than processes in between. Two process types, however, benefit more from derivative action than others, namely those with two identical poles and little delay as well as second order processes with one integrating pole and little delay.

In order to use software-based optimal design methods like the one described, it is important to have better modeling tools than what is normally available in the process industry. A simple step response test have been shown insufficient to design PI and PID controllers that are close to optimal. Research have shown that process information around the phase -125° is sufficient to find first order time delayed models for optimal PI control. For optimal PID control the model needs to be accurate around a larger span of phase angles from -125° down to around -235° . With the right modeling tools it should then be fairly easy to incorporate optimal software tuning into a new generation of autotuners that

will be far better than any existing PID tuning rules.

PID design by convex optimization

Convex optimization has grown to become a mature and powerful tool in a vast number of research fields. Design of PID controllers subject to robustness constraint is not a convex optimization problem, however, it fits well into the framework of the convex-concave procedure. Using that procedure, tuning algorithms for both SISO and MIMO PID controllers have been developed. Although globally optimal controllers cannot be guaranteed, the method produces robust controllers with good performance. The work is done in collaboration with Stephen Boyd, Stanford University.

Criteria and Trade-offs in PID Design

Control design is a rich problem which requires that many issues such as load disturbances and set-point tracking, model uncertainty, and measurement noise are taken into account. In this work we introduce trade-off plots for PI and PID controllers, which give insight into the design methods, criteria and design compromises.

The trade-off plot below is drawn for PI control of a second order delay-dominant process. The right plot is a magnification of the lower-left part of the left plot. The blue level curves show con-

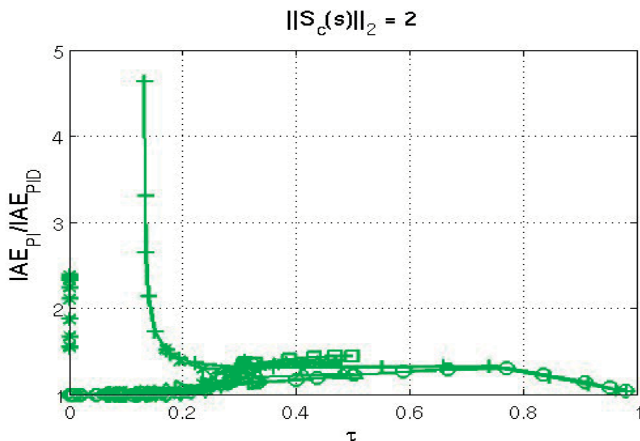

stant values of Integrated Absolute Error (IAE), equal to $1/ki$ (k_p is proportional gain and ki is integral gain), during a unit step load disturbance on the process input. The red level curves show constant values of $\max(M_s, M_t)$, where M_s is the max norm of the sensitivity function and M_t is the max norm of complementary sensitivity. The green, dash-dotted, line shows the loci of IAE optimal controllers for different values of $\max(M_s, M_t)$ and the green dot shows the absolute minimum. Five different tuning methods are shown in the plot, namely: Ziegler-Nichols step response method (Z-N), Lambda tuning, Skogestad's two SIMC methods (S and SM) and AMIGO tuning. The black line marked with triangles is a parametrization of the optimal controllers.

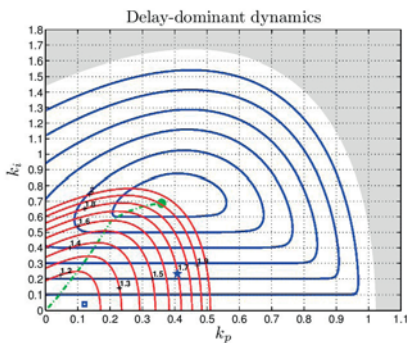

Interactive learning modules for PID control

We are also developing interactive learning modules for PID control. The modules are designed to speed up learning and to enhance understanding of the behaviour of loops with PID controllers. The modules are implemented in SysQuake, and the work is done in collaboration with professor Sebastián Dormido at UNED, Madrid, and José Luis Guzmán at Universidad de Almería.

The tools can be downloaded from Universidad de Almería.

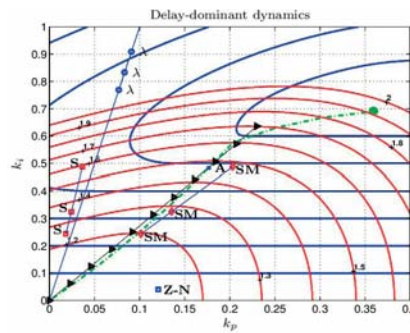

AUTOMATIC TUNING

Researchers: Josefin Berner, Kristian Soltesz, Tore Hägglund, Karl Johan Åström

Methods for automatic tuning of PID controllers were developed in the early eighties, and implemented in industrial single-station controllers and DCS systems. A main reason was the technology shift from analog to computer-based controllers and systems at that time, which made implementation of such tuning functions possible. These methods were limited by the computer power and the knowledge about PID design that were available at that time. Since then, the computational power and the knowledge about PID design has increased, which provides

the possibility to develop new tuning functions with better performance.

Within process industry, a large number of processes can be accurately modeled using simple models, i.e. SISO FOTD or SOTD, and there are efficient tuning rules for PID controllers that are based on these model structures.

We aim at developing a methodology for automatic tuning of PID controllers, using nonlinear feedback for identification input generation and optimization based methods for both process parameter identification and controller synthesis.

The main components of the auto-tuning algorithm are the following:

- Generate identification input with little or none a priori system information
- Transfer function parameter identification through optimization
- Model verification
- PID synthesis
- Performance evaluation

As a case study, a modified version of the method has been applied in closed-loop controlled anaesthesia.

Another approach for automatic tuning is to conduct a simple experiment, using an asym-

metric relay function as feedback. From the experiment the static gain and the normalized time delay of the system can be estimated, and from this a FOTD model can be achieved from analytical formulas. The experiment data can also be used to find a higher order model using numerical parameter estimation methods. From the achieved model the parameters of a PI or PID controller can be tuned either by existing tuning rules or by optimization methods.

This autotuner has been tried in both simulations and on an industrial air handling unit with promising results. Work on extending the autotuner to multivariable systems, as well as further development of the SISO version, is ongoing.

DECENTRALIZED CONTROL STRUCTURES

Researcher: Tore Hägglund

There is an unfortunate gap between the centralized computational approaches of multi-variable control theory and the common practice to design local control loops disregarding couplings and interaction. Today it appears that both approaches has reached a point of refinement where the gap can be reduced from both sides. This project aims to revise and improve the basic modules for decentralized control, and to develop new. The ideas to be investigated in this project are relevant not only for process control but is also of interest for general classes of multi-variable systems.

Low-order Feedforward Controllers

Feedforward is a powerful method to improve the performance of feedback loops. Feedforward can be made both from setpoint and measurable load disturbances. In this project, the goal is to improve both structures and design methods for feedforward control from load disturbances.

The basic idea for design of feedforward compensators is simple. The ideal compensator is formed as the dynamics between the load disturbance and the process output, divided by the dynamics between the control signal and the process output, with reversed sign. However this ideal compensator is seldom realizable. Therefore, there is a need for design methods. There are surprisingly few such methods presented in the literature, and the methods do normally not take

the feedback control into account in the design.

In a first phase, new simple tuning rules for feedforward compensators have been derived. The design objective is to minimize IAE without getting any overshoot in step load disturbance responses. This work has been done in collaboration with University of Almeria. This collaboration continues, and University of Brescia has also been involved in the project where e.g. performance indices for feedforward control have been developed.

Using a structure that decouples feedback and feedforward action, optimal design rules that minimizes ISE has been developed. The used structure simplifies tuning of the feedforward controller by allowing the controller to be tuned with respect to the open-loop system while maintaining its properties and perfor-

mance when used in a closed-loop setting. The structure also enables independent re-tuning of both the feedback and the feedforward controller. Work has also been done concerning characterization of optimal low-order feedforward controllers and practical considerations for implementation.

PID controllers is often implemented with set-point weighting to improve the response to changes in the reference. By using convex optimization techniques the parameters for the set-point weights can be found efficiently, fast as well as be guaranteed to be globally optimal. By solving an optimization problem to find the optimal set-point weights for a large batch of processes, tuning rules have been found that minimizes IAE. The same optimization framework and formulations can also be used to tune feedforward controllers from measurable disturbances.

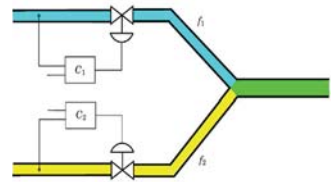

Ratio Control

In ratio control, the control objective is to keep the ratio between two signals, normally flow measurements, at a desired value in spite of variations in the setpoints, load disturbances, and possible control signal saturations. It is also desirable to keep the ratio also in situations when one of the controllers is switched to local setpoint or manual control.

There are methods available that manage to handle some of these disturbances, but no efficient method exists that handles all disturbances in both loops. The goal of the project is to obtain such a procedure. The project is supported by Vinnova.

OPTIMIZING FERMENTATION CONTROL FOR *B. LICHENIFORMIS*

Researchers: Ola Johnsson, Charlotta Johnsson, Tore Hägglund

This project is performed in collaboration with Novozymes A/S and Dept of Chemical Engineering, Lund University within the PICLU centre.

The project will focus on developing, improving and optimizing fermentation control strategies for the *B. licheniformis* fed batch processes. This process can produce vast amounts of protein but is sensitive to overdosing and process disturbances which lead to process variations and possibly crashed fermentations. There is thus a strong motivation for developing more robust control strategies for this process. The project aim is to develop a general method for finding optimal control strategies for various *B. licheniformis* production strains.

As part of this project, a general control strategy for control of bacterial growth in fed-batch processes has been developed and tested in pilot scale. Currently, the project is focused on

implementing this control strategy in production scale for trials in industry. Several pre-studies have been performed to verify that the strategy can be successfully applied for control of real industrial processes.



PIIA-METRICS

Researcher: Charlotta Johnsson in collaboration with Joakim Wikner and Sayeh Noorozi Linköping University.

Funding: Vinnova-PiiA

The focus of the project is to answer the questions ‘What key performance indicators are used in process industry today?’, ‘Do the key performance indicators differ depending on company characteristics?’ and ‘How can key performance indicators be exchanged between different software-applications?’

Today, it is more vital than ever for companies to have well articulated goals and clear strategies; with such in place, various navigation systems can be used in order to control the company towards their goals. Key performance indicators is one possible navigation system that can be used by managers at a company to understand if they are heading in the right direction or not. By using a well defined set of key performance indicators, areas in need of extra focus can be identified and relevant actions put in place.

Today, a large set of production data is collected every week, day, and hour. By analyzing the data set, important information about production can be obtained and presented as

key performance indicators, which will make it possible to make better decisions. However, it is important that companies do not collect data aimlessly but instead know what key performance indicators that can be used and what key performance indicators are most suitable for specific goals.

This project has the name ‘Process Industry Metrics (PI-metrics)’, and has its focus on key performance indicators, i.e. metrics, for the process industry.

The project will have three work packages (WP):

- WP1: What key performance indicators are used in process industry today?
- WP2: Do the key performance indicators differ depending on company characteristics?
- WP3: How can key performance indicators be exchanged between different software-applications?

DIG-PI

Researchers: Charlotta Johnsson in collaboration with Carsten Nokleby from Sesam-Sverige, and representatives from Perstorp, Specialty Chemicals AB, Tetra Pak Processing Systems, Södra Cell AB, Arla Foods, ÅF industry AB, Prevas AB, Hild, FPA Konsult AB, Rockwell Automation AB, Schneider-Electric AB, Siemens AB and B&R Industriautomation AB.

Funding: Vinnova-PiiA

This is a visionary project with the focus on “Digitalized Process Industry (DigPI)” and its possibilities to create benefits for the Process Industries in Sweden. The aim of this pre-study project (DigPI-1) is to specify visions, and goals for future Digitalized Process Industries, and in

a future full-sized research project (DigPI-2) set up a physical demonstration platform (testbed) where these visions and goals can be demonstrated. The pre-study is divided in four work-packages (WP):

- WP1: Identify a suitable process for the demonstration platform
- WP2: Define innovative concepts to be visualised in the demonstration platform
- WP3: Benchmark within the process industry
- WP4: Understanding of business benefits

For the most successful future regarding the development and direction of a Digitalised Process Industry, collaboration between the stakehol-

ders (solution-providers, end-users, integrators, network-organizations and academia) is key. The project partners in this pre-study (DigPI-1) consists of; one academic partner, one network-organisation, and 13 industry partners. Further, the industry partners includes 4 solution-providers, 5 end-users 2 integrators och 2 consultant companies.

SYSINT4.X

Researchers: Charlotta Johnsson and Jacob Mejvik in collaboration with Fredrik Heinz, Linköping University and Klas Nilsson, Sven G Robertz, Jacek Malec, Mattias Haage, Elin Topp, Dept of Computer Science, Lund University.

Funding: Vinnova

Increased digitization creates opportunities for increased productivity, but also several risks such as:

- Flexibility limited to overall (partly already digital) systems, while faults on the factory floor
- can be difficult to manage.
- Physical performance decreases if knowledge and practices of the staff is not taken care of.
- Proposed systems within Industry 4.x might not sufficiently consider business models and
- responsibilities of technology providers on a system level.
- Existing (well working) subsystems och equipment cannot be used efficiently.

The proposed project will together with industrial technology providers end users, and system integrators, investigate these and other productivity-related problems, and propose a new initiative including appropriate stakeholders from both industry and academia. There will be an emphasis on manufacturing systems that in-

clude robots since those systems impose special demands on the combination of flexibility and motion performance.

During the formation of Industry 4.0 the applicants were involved in several relevant EU projects together with German partners. This has resulted in several solution, patents and new business, but benefits for Swedish industry has been deficient. The proposed planning project combines via a Lund-Linköping collaboration the industrial experiences with related relevant research within academia and upcoming within WASP. Several other stakeholders at different locations will be part of a bigger initiative, which will be formed such that it is complementary to other projects.

ROBOTICS

Robotics Research

Robotics Lab

SMErobotics

Flexi-Fab

SARAFun

Semantic mapping and visual navigation for smart robots

ROBOTICS RESEARCH

Researchers: Rolf Johansson, Anders Robertsson, Olof Sörnmo, Björn Olofsson, Karl-Erik Årzén, Mahdi Ghazaei, Fredrik Bagge Carlson, Anders Blomdell, Anders Nilsson, Martin Karlsson and Pål Johan From in close cooperation with colleagues from neighbor departments at the Robotics lab at LTH, Lund University, and ABB Robotics/CRC, Västerås, Sweden.

Robotics offers both theoretical and practical challenges. Robotics is a multi-disciplinary topic and we collaborate with both national and international robotics colleagues regarding different aspects of robotics and we also have a close cooperation with industrial partners. Our main research are in motion and compliance control, control system architectures and different sensor fusion problems with application mainly to industrial manipulators. We use mainly modified and extended ABB robot control systems as experimental platforms

The laboratory for robotics and real-time systems is centered around industrial manipulators with open control system architectures. In the lab we have several generations of robots from an elderly ABB IRB6 robot, an ABB IRB2000 robot, an ABB Irb2400 (S4CPlus) to the more modern ABB IRB140 (IRC5), Gantry-Tau robot (IRC5), ABB IRB120 (IRC5) and the latest dual-arm concept robot Frida (ABB IRC5). Hardware interfaces have been developed to create an open system suitable for control experiments (Orca/Orcinus). The computer hardware is either PCI-based with both microprocessors and signal processors integrated into an embedded system for hard



realtime control in one of the labs and integrated with an additional PCI-based G4 PowerPC for the new Open Control system based on S4CPLUS and the newly developed networked architecture running on Linux/Xenomai-platforms.

The systems are connected to a network with workstations, which are used for program development and control design. A purpose of the current project is to show how to organize open robot control systems and to verify these ideas by means of experiments.

One goal is to permit efficient specification and generation of fast robot motions along a geometric path which requires coordinated

adjustment of the individual joint motions. Another aspect of robot motion control is how to integrate simultaneous control of force and position according to ideas of impedance control in which stability is an important theoretical issue. A major topic in this project is to integrate aspects of control, sensor fusion and application demands using robot vision and force sensing. Another project is on the structure and programming of control systems for industrial robots. The problem addressed is how the software architecture and the realtime structure of a robot control system should be designed to allow easy and flexible incorporation of additional sensors and new control algorithms.

A software layer between a supervisory sequence control layer and the basic control level has been proposed. Case studies and prototype experiments show promising results and further implementation is going on. The project Autofett aimed towards use of force control in manufacturing operations such as robotized fettling and is now continued in the SMErobot and FlexAA-projects. New sensor interfaces with modification of hardware and realtime software architectures have been developed to accommodate the use of force control algorithms based on workspace sensing. The research in this area has been awarded with e.g., the EURON Technology Transfer award and ICRA Best Automation paper.

ROBOTICS LAB

Robot control systems and other manufacturing equipment are traditionally closed. This circumstance has hampered system integration of manipulators, sensors and other equipment. As a result, such system integration has often been made at an unsuitably high hierarchical level.

The purpose of past and present projects is to show how to organize open robot control systems and to verify these ideas by means of experimental verification. As a part of this research,

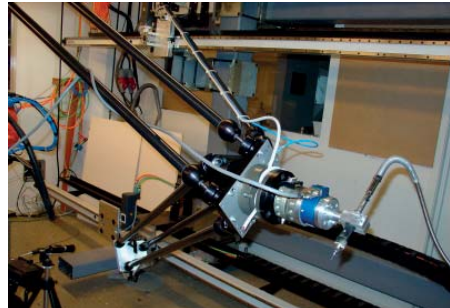

Several research interests are represented in Robotics Lab:

- Open Control Software Architectures
- Exteroceptive Robots
- Force Control
- Robot Vision
- Sensor Fusion
- Adaptive and Iterative Learning Control
- Task-level Programming
- Productive Robotics & Work-space Sensing



we have developed several experimental open robot control systems. The systems are built around industrially available robots that have been reconfigured for experimental purposes.

The developed specific robot interfaces and the integration of the robots into a complete system forms a unique environment for testing and development of algorithms for improvement of performance, sensor integration, programming automation and autonomous operation.

SMEROBOTICS

Researchers: Rolf Johansson, Anders Robertsson, Björn Olofsson, Olof Sörnmo

Funding: European Union FP7, under the programme SMERobotics

Over two-thirds of European workers in manufacturing are employed in small and medium-sized enterprises (SMEs). Their primary means of competition is to respond rapidly to changing production needs and to keep product quality at a very high level. While robots are able to carry out repetitive tasks to a high standard, they do not meet the demands of SMEs for high flexibility. Today's robots know only their nominal task, which limits their ability to deal with frequent changes in the manufacturing process. For the operation of robots in an SME environment, which is typically less structured and involves more uncertainties than large-scale or mass-production industries, the currently available solutions result in overly complex system integration.

Instead, cognitive abilities should be included in the equipment and cognition should take place in both the robot and the human, such that the worker's knowledge can be fully utilised and productivity demands can be met. Additionally, the concepts and symbols used in dialogues need to have a common grounding in order to guarantee ease of use.

Therefore, we propose the SMERobotics work system, which covers all phases of the robot lifecycle and in which humans and robots can together deal with SME manufacturing uncertainties and are symbiotically able to learn from each other and to learn from the past handling of uncertainties. The SMERobotics vision is to deploy such robots on SME shop floors, with the benefit of long-term improvements in productivity.

The SMERobotics initiative pays careful attention to SME-related issues and scientific challenges, as is reflected by its strong industrial involvement supported by leading researchers and building on successful collaboration between industry and academia as well as on demonstration-driven research from the SMERobot project.

Additional partners will be included in order to widen the initiative's impact by transferring project results to European pilot applications of SME-compatible cognitive robot systems.

FLEXIFAB - FLEXIBLE FABRICATION OF LIGHTWEIGHT ALUMINUM STRUCTURES

Researchers: Rolf Johansson, Anders Robertsson, Fredrik Bagge Carlson, Martin Holmstrand, Martin Karlsson

Funding: European Union FP7, under the programme FlexiFab

The FlexiFab system will provide the following key competitive advantages to the European welding Industry

- Enable European fabricators, metal-workers and welding companies to effectively compete in the growing use of aluminum alloys in the light-weight transport sector.
- Capitalising on the increasing pressure to replace traditional iron and steel material with aluminum alloys to reduce weight and thus fuel consumption of vehicles, trains, ships/boats and aeroplanes.
- Reduce the costs associated with the fabrication of aluminum structures, especially

focused on components used within the transport sectors.

RobotLab@Lund will mainly work on the sensor integration, logging for weld status for automated quality assurance and control system of industrial robots for the frictions stir welding process.

The system will use friction stir welding technology (FSW), invented by one of the project partners, TWI, in the beginning of the 1990s. The welding method offers a number of benefits for aluminum joining/welding such as:

- Excellent weld mechanical properties.
- A mechanised repeatable process.
- No special pre-weld edge profiling or cleaning required.
- No shielding gas required.
- Low distortion and shrinkage due to solid-state nature of welding process.
- Welding in any position.
- High efficiency processing with very low energy consumption.
- Ability to weld the 'non-weldable' aluminium alloys such as the 2000 and 7000 series
- Operator Health & Safety benefits:
 1. No harmful welding fumes or hot metal spatter
 2. No UV radiation hazards.

SARAFUN - SMART ASSEMBLY ROBOTS WITH ADVANCED FUNCTIONALITIES

Researchers: Rolf Johansson, Anders Robertsson, Fredrik Bagge Carlson, Martin Karlsson

Funding: European Community's Framework Programme Horizon 2020 – under grant agreement No 644938 – SARAFun.

The SARAFun project has been formed to enable a non-expert user to integrate a new bi-manual assembly task on a robot in less than a day. This will be accomplished by augmenting the robot with cutting edge sensory and cognitive abilities as well as reasoning abilities required to plan and execute an assembly task.

Over the last 30 years, robots have brought remarkable efficiency gains to industrial manufacturers, mainly in the automotive industry. Traditional industrial robots perform their assignments in cages and are heavily dependent on hard automation that requires pre-specified fixtures and time-consuming programming and reprogramming performed by experienced software engineers. The assembly application has always been considered as a promising robotic application but in reality it has proven challenging to automate due to e.g., complex materials, precise grasping requirements, part variations, operations requiring high precision (snap fits), operations requiring special motions (twist insertions) and wear and tear of the assembly equipment. While robotic assembly does exist, it

has only been applied in a fraction of the potential cases. As a result, nowadays even expensive products produced in fairly large volumes, are still assembled manually in low wage countries under harsh conditions.

There is also a clear trend towards a shorter product lifetime. In order to be able to handle "burst" production (i.e. ramp up to full volume in very short time, run production for 3-12 months, and then change to new model) the lead time for setting up a production line/cell must be drastically reduced.



SEMANTIC MAPPING AND VISUAL NAVIGATION FOR SMART ROBOTS

Researchers: Marcus Greiff, Bo Bernhardsson, Anders Robertsson with colleagues from the Dept of Mathematics, Lund University and Chalmers University of Technology.

Funding: SSF

Why is it that today's autonomous systems for visual inference tasks are often restricted to a narrow set of scene types and controlled lab settings? Examining the best performing perceptual systems reveals that each inference task is solved with a specialized methodology. For instance, object recognition and 3D scene reconstruction, despite being strongly connected problems, are treated independently and an integrated theory is lacking. We believe that in order to reach further, it is necessary to develop smart systems that are capable of integrating the different aspects of vision in a collaborative manner. We gather expertise from computer vision, machine learning, automatic control and optimization with the ambitious goal of establishing such an integrated framework.

The research is structured into four work packages:

- scene modelling,
- visual recognition,
- visual navigation and
- system integration to achieve a perceptual robotic system for exploration and learning in unknown environments.

As a demonstrator, we will construct an autonomous system for visual inspection of a supermarket using small-scale, low-cost quadcopters. The system goes well beyond the current state-of-the-art and will provide a complete solution for semantic mapping and visual navigation. The basic research outcomes are relevant to a wide range of industrial applications including self-driving cars, unmanned surface vehicles, street-view modelling and flexible inspection in general.

AUTOMOTIVE SYSTEMS

KCFP, Closed-Loop Combustion Control

Projects devoted to vehicle dynamics and combustion control run in cooperation with major car manufacturers.

KCFP, CLOSED-LOOP COMBUSTION CONTROL

Researchers: Rolf Johansson, Gabriel Ingesson in cooperation with Lianhao Yin, Prof. Per Tunestål and Prof. Bengt Johansson, Div. Combustion Engines, Lund University

Competence Center Combustion Processes (KCFP) at Lund University focuses on research of combustion processes between HCCI (Homogeneous Charge Compression Ignition) and classical Otto and Diesel engines.

Project aims:

- Reducing emissions, improving efficiency and repeatability of HCCI and partially pre-mixed combustion (PPC) using closed-loop control;
- Control-oriented modeling and simulation of combustion processes;
- Model-based control and optimization evaluated on test beds.

Within the project a cycle-resolved physics-based HCCI model has been developed. The model includes a low-complexity model of the cylinder wall temperature dynamics in order to capture the relevant time-scales of transient HCCI when only small amounts of hot residuals are trapped in the cylinder. The temperature evolution of the gas charge is modeled as isentropic compression and expansion with three heat transfer events during each cycle.

Model predictive controllers based on linearizations of the model have been designed and evaluated experimentally. The considered con-

trol signals were the inlet valve closing and the intake temperature. The control performance was evaluated in terms of response time to set-point changes and the resulting output variance. The benefits of using hybrid models comprised of several linearizations of a nonlinear model have also been investigated.

During 2011, a continuous-time model of partially premixed combustion was developed and implemented in the Modelica language. The JModelica.org framework was used to formulate optimization problems on the resulting model. One use of this possibility is automatic calibration of the model parameters.

BIOMEDICAL PROJECTS

Hemodynamic Stabilization
Anesthesia in closed-loop
Surgeon's perspective

HEMODYNAMIC STABILIZATION

Researchers: Kristian Soltesz, Anders Robertsson, Rolf Johansson, in collaboration with Igelösa Life Science AB.

Funding: Vinnova through the Medtech4Health strategic innovation program

Objective

The aim of the project is to develop methods for hemodynamic stabilization of intensive care patients. It comprises closed-loop control of readily measurable signals, including heart rate, arterial and venous blood pressure. Furthermore, the project aims at optimizing hemodynamic parameters, which are not directly measurable, such as cardiac output and responsiveness to volume expansion.

The aim of the project is to develop a generic platform for closed-loop intravenous drug delivery. Apart from being used in research, such a platform can be adapted to a multitude of medical treatment scenarios, foremost in intensive care, where it has the potential to increase the availability of specialized physicians.

Description

The aim of the project is to provide physicians with an 'auto pilot' for hemodynamic stabilization and optimization.

The initially considered patient group are heart-beating braindead patients under intensive care (potential organ donors). Due to the complete loss of vasomotor center function, hormonal and fluid therapy is required to establish hemodynamic stability within this group.

We combine automatic control methods with medical insight, to develop closed-loop controlled therapies. Developed methods are

implemented on our in-house developed control system comprising sensors for invasive blood pressure measurement, and urination rate, as well as syringe and volumetric infusion pumps for closed-loop controlled intravenous drug and fluid administration.

The methods are pre-clinically evaluated in collaboration with the project partner Igelösa Life Science AB. Following successful initial experiments, we are looking into clinical evaluation of some of the developed methods.

Picture below: Hemodynamic stabilization system prototype, developed within the project.



ANESTHESIA IN CLOSED LOOP

Researchers: Kristian Soltesz in collaboration with professor Guy Dumont and the ECEM group, University of British Columbia, Vancouver, Canada.

Acknowledgement: The project would not have been possible to perform without the support from LCCC.

Objective

To develop an automatic control system for anesthesia.

Description

Computer controlled, or automatic, drug delivery is the process of administering a therapeutic regime to a patient with computer assistance for calculation of optimal dose and delivery schedules. Computer control can improve drug therapy by reducing drug usage and costs, by permitting health care staff to work more efficiently and to provide better standard of care, by allowing the safe use of drugs that are difficult to administer, and by compensation for human failings with computer strengths, such as unlimited attention span and patience, and capacity for quick, accurate and redundant calculation.

Our goal is to develop an automatic control system for anesthesia and to demonstrate its efficacy, safety and benefits in an operating room. Although closed-loop anesthesia has previously

been proposed and tested, it has yet to have a significant impact on clinical practice. Recent developments in sensing for anesthesia have opened new possibilities for closing the loop. Our research will focus on the deployment of new sensors optimized for controlled drug delivery, robust control methodology and extensive clinical validation.

Clinical partner in the project is the Department of Anesthesia at the British Columbia Children's Hospital (BCCH), Vancouver, Canada, where patient modeling data is collected and clinical trials of the control system are conducted.

A PID controller based drug delivery system for depth of hypnosis control was evaluated in a patient study (BCCH REB approval H10-01174) during 2011.

Our current aim is to extend the system to control hypnosis and analgesia simultaneously, by adding a second drug.



SURGEON'S PERSPECTIVE

Researchers: Charlotta Johnsson, in collaboration with Kiet Tran Skåne University Hospital Lund, Jonas Unger, Linköping University, Christer Mårtensson Business Region Skåne

Funding: Vinnova - UDI

The live surgical field, as the surgeon visually perceives it, contains invaluable image information needed for surgical training, clinical consultations and support the development of surgical robots. However, access to the surgeon's view of the reality is highly restricted because there are currently no technical solutions to collect, reproduce, and share this 3-D image information. At the present, only the surgeon can see the organs and pathologies that need surgical attention. The goal of this project is to develop technical solutions to collect image data during open heart surgery, and to reproduce 3-D heart models that can be used for education, clinical

consultations, and in the future advance the development of autonomous robotic systems. The overall goal is to achieve increased safety and quality in surgical care.

Components that will be developed:

- A camera system for collection of 3-D video images.
- A platform for interactive visualisation of the surgical field.
- A database that within 3 years will collect data from 5000-10000 surgical cases, for use in machine learning algorithms, augmented reality, and robotic surgery.

TOOLS AND SOFTWARE

JGRAFCHART

Jitterbug: A Matlab toolbox for real-time control performance analysis

JMODELICA.ORG

MPCtools

TrueTime: Simulation of Networked and Embedded Control Systems

Downloadable software developed at the department

JGRAFCHART

Grafchart is a language for supervisory level sequence control and procedure handling that has been developed at the department since 1991. Grafchart is based on ideas from Grafcet/Sequential Function Charts, Petri nets, Statecharts, and object-oriented programming.

The original implementation of Grafchart had the same name and was developed in G2 from Gensym Corporation. Using this platform Grafchart was used for batch recipe control, diagnosis of mode-changing processes, alarm filtering, implementation of operator decision support systems, and implementation of robot cells.

In 2001 an open implementation of Grafchart was made in Java. It is called JGrafchart and is used in our laboratory exercises on logical sequence control and batch control as well as in several research projects, for example, Grafchart for Industrial Automation and PRACE. It has also been used within the EU/GROWTH project CHEM for control in process industry, the EU FR7 project ROSETTA for robotic assembly, and several master's theses for example for modeling or code generation. DFKI has used it to implement the coordination of several demonstrators with real industrial equipment. Finally, there are a few cases where it is used for live industrial control, for example, myvision MANUFACTO.

JGrafchart is available for download as free-ware.

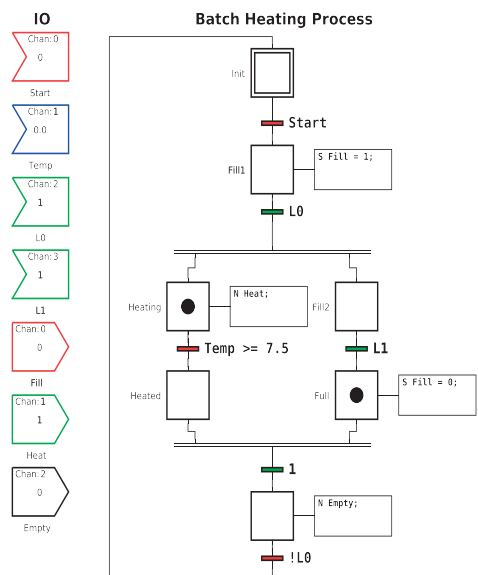

Control of a Batch Heating Process implemented in JGrafchart.

JITTERBUG: A MATLAB TOOLBOX FOR REAL-TIME CONTROL PERFORMANCE ANALYSIS

JITTERBUG is a MATLAB-based toolbox that allows the computation of a quadratic performance criterion for a linear control system under various timing conditions. Using the toolbox, one can easily and quickly assert how sensitive a control system is to delay, jitter, lost samples, etc., without resorting to simulation. The tool is quite general and can also be used to investigate jitter-compensating controllers, a periodic

controllers, and multi-rate controllers. As an additional feature, it is also possible to compute the spectral density of the signals in the control system. The main contribution of the toolbox, which is built on well-known theory (LQG theory and jump linear systems), is to make it easy to apply this type of stochastic analysis to a wide range of problems.

JMODELICA.ORG

JModelica.org is an extensible Modelica-based open source platform for optimization, simulation and analysis of complex dynamic systems. The main objective of the project is to create an industrially viable open source platform for optimization of Modelica models, while offering a flexible platform serving as a virtual lab for algorithm development and research. As such, JModelica.org provides a platform for

technology transfer where industrially relevant problems can inspire new research and where state of the art algorithms can be propagated from academia into industrial use. JModelica.org is a result of research at the Department of Automatic Control, Lund University, and is now maintained and developed by Modelon AB in collaboration with academia.

MPCTOOLS

MPCtools is a freely available Matlab/Simulink-based toolbox for simulation of MPC controllers. MPCtools provides easy to use functions to create and simulate basic MPC controllers based on linear state space models.

The key features of the toolbox include:

- Support for linear state space models for prediction
- Quadratic cost function
- Linear inequality constraints on states and controls
- Observer support for state and disturbance estimation
- Integral action by means of disturbance estimation
- Two different QP solvers for solving the optimization problem

TRUETIME: SIMULATION OF NETWORKED AND EMBEDDED CONTROL SYSTEMS

TrueTime is a Matlab/Simulink-based simulator for real-time control systems. Offering Simulink blocks that model real-time kernels and wired/wireless networks, TrueTime facilitates co-simulation of scheduling algorithms, control tasks, network protocols, and continuous plant dynamics.

TrueTime has been developed at the Department of Automatic Control since 1999. It is open source, written in C++, and can easily be

extended with new functionality. TrueTime has been used in wide range of research projects and has also found use in university courses and in industry.

During 2016, a stable version 2.0 of TrueTime was finalized and released. TrueTime was also presented at the 1st Tutorial on Tools for Real-Time Systems in conjunction with the Cyber-Physical Week in Vienna, Austria.

External Contacts

External contacts during 2016, both academic and industrial

Together with external contacts and partners the goal is to solve real control problems. A mix of fundamental and applied work is a cornerstone of our activities. In these kind of projects the problems are approached with an open mind without glancing at particular methods. One purpose is to learn about real problems, another is to learn about new problems that are suitable for theoretical research. An important role for universities is to organize knowledge in such a way that the results can easily be digested by engineers in industry. There is naturally a strong symbiosis with teaching in this activity. A good mechanism is thus to introduce new research material into existing and new courses. A related form of technology transfer is to write books and monographs and to develop software. Exchange of personnel between industry and university is another very effective vehicle for technology transfer.

ACADEMIC CONTACTS

We have very good and fruitful relations and cooperations with a number of universities and academic institutions throughout the world. This year we have had important contacts with;

Beckman Research Institute of City of Hope National Medical Center, Duarte (CA), USA
 Carnegie Mellon University, USA.
 Charles University in Prague, Dept of Distributed and Dependable Systems, Czech Republic
 City College London, Dept of Informatics. England
 Czech Technical University, Faculty of Information Technology, Czech Republic
 DFKI, SmartFactory, Kaiserslautern, Germany
 Dublin City University, Ireland
 ETH Zurich, Automatic Control Laboratory, Switzerland
 European Innovation Academy, EU
 Hanyang University, Seoul, Korea
 Hasso Plattner Institute for Software Systems Engineering, Software Competence Center Hagenberg
 Imperial College, London, Dept of Computing, England
 INRIA / University of Lille, France
 KU Leuven, Dept of Mechanical Engineering, Belgium
 Linköping University, ISY, Sweden
 Linneaus University, Dept of Computer Science, Sweden
 Lund University, Centre for Mathematical Sciences, Sweden
 Lund University, Dept of Chemical Engineering, Sweden
 Lund University, Dept of Computer Science, Sweden
 Lund University, Design Science, LTH, Sweden
 Lund University, Dept of Electrical and Information Technology, Lund, Sweden
 Lund University, Division of Mechanics, LTH, Sweden
 Lund University, Machine Design, LTH, Sweden
 Maschine Strahlkontrollen group vid Deutsches Elektronen-Synchrotron (DESY), Germany
 Massachusetts Institute of Technology, Computer Science and Artificial Intelligence Laboratory, USA
 Norwegian University of Science and Technology (NTNU), Dept of Chemical Engineering, Trondheim, Norway
 Norwegian University of Science and Technology, Dept of Engineering Cybernetics,
 Politecnico di Milano, Milano, Italy.

Politecnico di Milano, Dipartimento di Elettronica, Informazione e Bioingegneria, Italy
 St. Petersburg State University, Russia Scuola Superiore Sant'Anna, Dipartimento di Informatica, Italy
 Tsinghua University, Dept Precision Instruments and Mechanology, Beijing, China
 Umeå University, Dept of Computing Science, Sweden
 Umeå University, Dept. of Applied Physics and Electronics, Sweden
 UNED, Spain
 Universidad de Almeria, Spain
 Universidad de Buenos Aires, Departamento de Computación, Ciencias Exactas y Naturales, Argentina
 Universität Duisburg-Essen, Dept of Informatics, Germany
 Universität Kaiserslautern, Germany
 University of Brescia, Italy
 University of British Columbia (UBC), Electrical and Computer Engineering in Medicine (ECEM),
 Vancouver, Canada
 University of California at Riverside, Department of Mechanical Engineering, USA.
 University of California, Sutardja Center for Entrepreneurship and Technology, Berkeley, USA USA
 University of Chicago, Department of Computer Science, USA
 University of Jyväskylä, Finland
 University of Minnesota, Institute for Mathematics and its Applications (IMA), USA.
 University of Palermo, Dipartimento di Ingegneria Chimica, Gestionale, Informatica, Meccanica, Italy.
 University of Sheffield, Department of Automatic Control and Systems Engineering, UK.
 University of Trieste, Dipartimento di Ingegneria e Architettura, Italy.
 University of Udine, Dipartimento di Scienze Matematiche, Informatiche e Fisiche, Italy.
 University of Udine, Dipartimento Politecnico di Ingegneria e Architettura, Italy.
 University of Toronto, Department of Computer Science, Canada
 University of Trento, Dipartimento di Informatica, Italy
 Zhejiang University (ZJU), Control Science and Engineering, Hangzhou, China

INDUSTRIAL CONTACTS

We have very good working relations with many companies and organizations. The interactions are at different levels and of different intensities, from visits and discussions to joint projects. Master's Theses and education are also important ingredients. During the year we have had major projects with;

3E, Belgium
 AAK, Sweden
 ABB Corporate Research, Västerås, Sweden
 ABB Robotics, Sweden
 ÅF industry AB, Sweden
 Akzonobel, Ningbo, China
 Arla Foods, Sweden
 Axis Communications AB, Lund, Sweden
 B&R Industriautomation, Sweden
 Business Region Skåne, Sweden

Cognibotics, Sweden
Corebon, Sweden
Deutsches Elektronen-Synchrotron DESY, Maschine Strahlkontrolle group, Hamburg, Germany
Ericsson, Lund, Sweden
European Spallation Source (ESS), Lund Sweden
Fraunhofer IPA, Stuttgart, Germany
FPA Konsult AB, Trollhättan, Sweden
Gudel AG, Switzerland
Hild, Denmark
Igelösa Life Science AB, Igelösa, Sweden
Institut Pasteur, Paris, France
Laboratoire d'Immunologie et d'Histocompatibilité, Hôpital Saint-Louis, AP-HP, Paris, France.
Modelon AB, Sweden
Novozymes AS, Denmark
Perstorp Specialty Chemicals AB, Sweden
Prevas AB, Sweden
Rockwell Automation AB, Sweden
Scania, Södertälje, Sweden
SAAB AB, Linköping, Sweden
Schneider Electric AB, Sweden
Siemens AB, Sweden
Skåne University Hospital, Pediatric Heart Surgery, Sweden
Södra Cell AB, Sweden
Tetra Pak Processing Systems, Sweden
TWI Ltd, UK
Volvo Cars, Gothenburg, Sweden

EUROPEAN COLLABORATIONS

During 2016 the department was involved in the 7th Framework Program of the European Commission and Horizon 2020, in the below listed projects;

- SMERobotics Consortium
- Flexi-Fab Consortium
- SARAFun Consortium

Staff

During 2016, the staff situation at Automatic Control remains solid. Six new PhD students have been employed. We have also had the pleasure of hosting international guests for shorter or longer periods.

In the coming parts the personnel and its activities will be described.



Picture taken at Kick-off in August 2016

STAFF**PERSONNEL AND VISITORS****PROFESSORS**

Årzén, Karl-Erik
Åström, Karl Johan, senior professor
Bernhardsson, Bo, deputy head of department
Eker, Johan, adjunct professor
Hagander, Per, professor emeritus
Hägglund, Tore, head of department
Johansson, Rolf
Rantzer, Anders
Robertsson, Anders
Wittenmark, Björn, professor emeritus

ASSOCIATE PROFESSORS

Cervin, Anton
Como, Giacomo
Giselsson, Pontus (from December)
Johnsson, Charlotta

ASSISTANT PROFESSOR

Maggio, Martina

RESEARCH ENGINEERS

Andersson, Leif (30%)
Andersson, Pontus
Blomdell, Anders
Nilsson, Anders

ADMINISTRATORS

Nilsson, Ingrid
Nishimura, Mika
Rasmusson, Monika (65%)
Westin, Eva

POSTDOCTORS

Chong, Michelle
Giordano, Giulia (from June)
Papadopoulos, Alessandro V (until February)
Pates, Richard
Soltész, Kristian

RESEARCHERS

Olofsson, Björn
Perninge, Magnus (until September)

PHD STUDENTS

Bagge Carlson, Fredrik
Bergstedt, Jacob
Berner, Josefin
Dellkrantz, Manfred
Dürango, Jonas (until June)
Fält, Mattias
Ghazaei, Mahdi
Grussler, Christian
Heyden, Martin (from October)
Ingesson, Gabriel
Johnsson, Ola (until August)
Karlsson, Martin
Lidström, Carolina
Magnusson, Fredrik
Mannesson, Anders (until June)
Mejvik, Jacob (from November)
Millnert, Victor
Nayak Seetanadi, Gautham
Nilsson, Gustav
Nylander, Tommi (from January)
Sadeghi, Hamed (from August)
Sörnmo, Olof (until June)
Stemmann, Meike (until June)
Stolt, Andreas (until January)
Thelander Andrén, Marcus
Troeng, Olof
Xu, Yang

INDUSTRIAL PHD STUDENTS

Martins, Alexandre (from April), Axis
Petersson, Anders, SAAB
Skarin, Per (from August), Ericsson

SHORTER AND LONGER STAYS

Annergren, Mariette; visiting PhD student, KTH, Sweden (until June)

Hagdrup, Morten; visiting PhD student, Technical University of Denmark (Sep – Nov)

Mirkin, Leonid; visiting professor, Technion, Israel (June)

Simoni, Luca; visiting PhD student, University of Brescia, Italy (Sep - Nov)

Zhu, Li; visiting postdoc, Dalian University of Technology, China (from December)

Zorzan, Irene; visiting PhD student, University of Padova, Italy, (from September)

STAFF ACTIVITIES

Andersson, Leif

MSc, Research Engineer since 1970. Leif started at the department with responsibility for the teaching and research laboratory. After some years he drifted to computer maintenance and became computer manager. He resigned formally in 2012, but was immediately rehired on 30%.

A large part of his time the past year has been spent updating the department publication database with entries for older publications, and also transferring it to the new central university publication database, LUCRIS. The aim has been to have all publications going back to the department start in 1965 registered in the database, to a large extent including fulltext.

Andersson, Pontus

MSc, Research Engineer at the department since 2012.

His main tasks include maintenance and development of laboratory equipment and also mechanic and electronic design and implementation. Involved in various projects in the Robotics Lab.

Spring 2016 devoted to preparation for the Automatica Fair in Münich.

During 2016 also involved in a research project for high-precision temperature stabilisation for the phase-reference control at ESS.

Årzén, Karl-Erik

Professor (2000), PhD (1987): Joined the department in 1981. His research interests are real-time and embedded control, real-time systems, cloud control, feedback computing, autonomous sys-

tems, and programming languages for control.

Co-director for the strategic research area EL-LIIT on IT and mobile computing. Coordinator for the Lund part of WASP (Wallenberg Autonomous Systems Program). During the year he has primarily been involved with WASP and the VR project Feedback Computing for Cyber-Physical Systems.

He is partly or fully involved in the supervision of six PhD students.

Åström, Karl Johan

Professor in Automatic Control since 1965 and founder of the department, emeritus from 2000, senior professor since 2010.

Co-supervised Josefin Berner student on PID control and automatic tuning.

Visited UCLA and Caltech in March, 2016.

Bagge Carlson, Fredrik

M.Sc., Ph.D. Student. He has been with the department since 2013.

My research interests include machine learning and system identification within robotics. I'm active within the project SARAFun.

During the fall 2016 I gave lectures in automatic control, basic course, at Zhejiang University, China. Other teaching responsibilities include the courses System identification, predictive control and deep learning.

I also co-supervised the master thesis of Marcus Greiff.

Bergstedt, Jacob

Jacob Antonsson has been a PhD student at the department since august in 2013.

He is interested in statistical modeling and in-

ference for complex systems, using for instance mixed models and various non-parametric models. He tries to apply state-of-the-art research results in those areas to applied fields like statistical genetics and robotics.

During 2016 he has been working with statistical modeling of data related to the human immune system within the Milieu Interieur project at the Pasteur Institute in Paris. .

Berner, Josefin

Tech. Lic., MSc in Engineering Physics, PhD student since August 2012.

Her research interests are in automatic tuning of PID controllers and she is currently working on extending the autotuner to multivariable systems.

During the year she has taken some courses, been a teaching assistant in the courses on Market-driven systems, Process control/Systems Engineering and Multivariable control.

She has also been a member of the research education council at LTH since May 2016.

Bernhardsson, Bo

PhD 1992, Professor since 1999, has also worked at Ericsson for 9 year.

He is the vice head of the department and a member of the LCCC board. He is also one of the organizers of the WASP research school.

During 2016 Bo has also worked part time in a project for the European Spallation Source with the design of the RF system for the proton accelerator. His research interests are in linear systems, applications of control theory and the connection between communication theory and control theory.

During 2016 he taught one of the basic courses in Automatic Control and held a PhD course in Control System Synthesis (with KJ Åström) and a reading group in Deep Learning. He is the supervisor or co-supervisor of 8 PhD students.

Blomdell, Anders

Research Engineer at the department since 1988. Heavily involved in almost all aspects of

Robotics research at the department, also responsible for the department network and lab computers for teaching and research.

During 2016 the entire spring was devoted to preparing the Automatica Trade Fair and the time after that has been spent recuperating and catching up with everything put on hold during the preparations.

In short, 2016 was a typical Automatica year.

Cervin, Anton

PhD (2003), Associate Professor (2007), Docent (2008), Director of PhD Studies.

Anton's research interests include real-time systems, event-based and networked control, and computer tools for analysis and simulation of controller timing. He is currently supervising two PhD students.

During 2016 he was lecturer in the advanced-level courses Real-Time Systems and Multivariable Control, and he was supervisor or examiner for four Master's theses.

He was also responsible for two PhD courses given as study circles: Programming Languages and Concepts and History of Control.

Chong, Michelle

PhD (2013). She joined the department as a LCCC postdoc in August 2015. Research interest in estimation and control for nonlinear systems with applications in cyber security and neuroscience.

Received best paper award at the 2016 ACM/IEEE 7th International Conference on Cyber-Physical Systems for *SMT-based observer design for cyber-physical systems under sensor attacks*.

Co-lectured PhD course on 'Linear Systems' from Oct-Dec 2016.

Co-supervisor for Martin Heyden in his master's thesis *Classification of EEG data using machine learning techniques*.

Como, Giacomo

PhD (2008), Docent (2012). He has been with the faculty at the Department of Automatic Control since 2011 and was promoted Associate

Professor (universitetslektor) in 2013.

His research interests are in Dynamics, Information, and Control in Networks, with applications to transport, infrastructure, as well as social and economic systems.

He is currently a board member of LCCC and of the Department of Automatic Control. He has served as main supervisor of Gustav Nilsson and co-supervisor of Hamed Sadeghi and Martin Heyden.

In Spring 2016, he taught the master level course Network Dynamics at Lund University. During 2016, he also taught invited PhD courses on Network Dynamics at Uppsala University (April) and the Gran Sassa Science Institute (May).

He has been on leave at the Lagrange Department of Mathematical Sciences of Politecnico di Torino since September 2016.

Dellkrantz, Manfred

PhD student at the department since 2012 supervised by Anders Robertsson and Maria Kihl. Working with delay-compensated feedback for autocalcing of cloud applications.

Defended his licentiate dissertation *Modeling and Control of Server-based Systems* in May.

Was involved in teaching Real-Time Systems during the spring and Basic Course during the fall.

Dürango, Jonas

MSc in Engineering Physics, with the department as a PhD student since 2010, supervised by Bo Bernhardsson and Martina Maggio.

In June he presented his licentiate thesis, *Control Strategies for Improving Cloud Service Robustness*.

Eker, Johan

Johan is an Adjunct Professor at 20% and a Principal Researcher at Ericsson Research at 80%. His main research areas are resource management for real-time systems, cloud computing and tools and methodologies for many- and multicore systems.

Fält, Mattias

Mattias is a PhD student at the Department of Automatic Control since 2015.

His main research interest is methods for large-scale convex optimization. The focus is on line-search methods and relaxed projection algorithms. He is working on devising new algorithms as well as improving existing ones. The work consists of both theoretical analysis and creation of a software package for illustration and easy use of the algorithms.

Ghazaei Ardakani, M Mahdi

In the beginning of 2012, he joined the department of Automatic Control as a PhD student. His research interests include robotics, systems and control theory, machine learning, and dynamic simulation.

On 21st of December 2016, he defended his PhD thesis titled *On Trajectory Generation for Robots*. The opponent was Dr. Torsten Kröger from Stanford University/Google Inc.

He was also involved in basic control, nonlinear, and applied robotics courses in the capacity of teaching assistant and lab supervisor.

Giordano, Giulia

Giulia joined the Department as a Postdoctoral Researcher in June 2016. She received her B.Sc. (2010) and M.Sc. (2012) degrees in Electrical Engineering and her Ph.D. (2016) from the University of Udine.

Her main research interests include the analysis and the control of dynamical networks. In particular, she is interested in the structural analysis of dynamical systems endowed with a network topology, aimed at assessing structural (parameter-free) properties that exclusively depend on the interconnection topology, with applications to biological systems and biochemical reaction networks. As for the control of networked systems, she is primarily interested in network-decentralised strategies that are aimed at governing the global system behaviour by acting locally and based on local information (precisely, the control agent connecting a set of

subsystems is acting on these subsystems only and decides its strategy based exclusively on the knowledge of the state of the subsystems it connects).

Giselsson, Pontus

Pontus is currently an Associate Professor at the Department of Automatic control. He received his MSc from Lund University in 2006 and his PhD from the Department of Automatic Control in at Lund University 2012.

His research interests are in convex optimization and its wide range of applications.

During 2016, Pontus was responsible for the undergraduate level courses in Systems Engineering and Process Control.

He is co-supervising three PhD students.

Grusser, Christian

Since 2012, I am a PhD-student at Lund University. So far, my research interests included Model reduction, Cone invariant systems, and Optimization with Sparsity and Low-rank constraints.

From January 21st till February 21st, I was invited to participate in the Thematic Year on Control Theory and its Applications at the Institute for Mathematics in and its Applications (IMA) in Minneapolis. This visit resulted in a collaboration with Armin Zare and Mihailo Jovanovic and the joint conference paper "The Use of the r^* Heuristic in Covariance Completion Problems", which was presented at the 55th IEEE Conference on Decision and Control.

Hägglund, Tore

Professor, PhD (1984). Has been at the department since 1978 except for four years when he worked for ABB.

Responsible for two of the basic courses in Automatic Control in the engineering program. Main research interests include process control, PID control, adaptive control, control loop monitoring and diagnosis. Main research activities during the year have been design of PID controllers and decentralized control structures.

Tore Hägglund is also head of the department

and deputy centre director of "Centre for Research and Competence Development for the Process Industry", PIC-LU.

Heyden, Martin

MSc in Engineering Physics (2016) and PhD student since October 2016.

Working with SSF-SoPhy, supervised by Anders Rantzer.

During the fall Martin has been a teaching assistant in the basic course while talking courses himself.

Ingesson, Gabriel

PhD student since January 2013. He is working with Professor Rolf Johansson and Professor Per Tunestål in the KCFP PPC Control project, which is a cooperation with the Division of Combustion Engines. Gabriel is studying control-related problems in partially premixed combustion (PPC) engines.

In the beginning of 2016 Gabriel completed a 3 month internship at Scania AB where he studied fluid dynamics in common-rail systems.

During 2016, Gabriel also contributed to the MOVIC & RASD conference 2016 at University of Southampton, the 8th IFAC Symposium on Advances in Automotive Control, AAC 2016, Kolmården, Sweden and the SAE world congress 2016, Detroit. The presented work covered predictive control for avoidance of knock and misfire when running compression-ignition engines with fuels of higher octane number and adaptive virtual sensors for combustion diagnostics.

Gabriel has during the year been a teaching assistant in the multi-variable control course and in the real-time systems course.

Johansson, Rolf

Professor, MD, PhD. Active at the department since 1979. His research interests are in system identification, robotics and nonlinear systems and automotive control.

He is participates and leads the research projects Flexi-Fab, KCFP Control, SARAFun, SMERobotics, and VR Active Control.

He is coordinating director for Robotics Laboratory with cooperation partners from Dept Computer Science and industrial partners.

He has industrial cooperation with ABB Robotics, ABB Corporate Research, Scania and Volvo.

He is responsible for the three courses FRT041 System Identification, FRTN15 Predictive Control, and FRTF01 Physiological Models and Computation.

Rolf is also supervising a number of both students and PhDs.

Johnsson, Charlotta

Research Associate, PhD (1999). Charlotta has been at the department since 1993 except for 4 years (2000-2004) when she worked in industry.

Charlotta's main research interest is in Production Control, Operations Management, Smart Manufacturing, Pedagogy and Innovation.

She is involved in ISO and IEC standardization activities and part of the management team for the research centers LCCC, PIC-LU and LISA2.

Johnsson, Ola

Tech. Lic, MSc in Biotechnical Engineering, graduate student since August 2010. Works within the field of fermentation control, in cooperation with Novozymes A/S.

Defended his PhD thesis titled *Perturbation-based Control of Industrial Fed-batch Bioprocesses* in January, 2016.

Karlsson, Martin

He has worked as a Ph.D student since April 2014. His research interests are within state estimation, and robot learning and control.

In 2016, he has been working within the EU projects SARAFun, with focus on robot learning for assembly tasks, and FlexiFab, in which friction stir welding performed by a manipulator was developed.

He has worked as a teaching assistant in Systems Engineering/Process Control, Applied Robotics and Projects in Automatic Control.

Lidström, Carolina

Lic. Tech., MSc in Engineering Physics. PhD student since June 2013. Her research interests include scalable and distributed control, with applications in power networks.

In June she presented her licentiate thesis, *On Scalable H-infinity Control*.

She was a visiting student at the Institute for Mathematics and its Applications, University of Minnesota, Minneapolis, USA, in May.

During the fall she was a teaching assistant in the course Physiological Models and Computation and co-supervised a Master's thesis project.

Maggio, Martina

Martina Maggio has been a Postdoctoral Researcher at the department since January 2012 and became an Assistant Professor in August 2014. She is leading the project on control for power and temperature in computing datacenter, that has strong connections with the cloud control project.

During 2016 she has been teaching in the Real-Time Systems course. She also supervised a thesis on resource allocation for camera platforms, performed in joint collaboration with Axis Technology. She is co-supervising Gautham Nayak Seetanadi towards his PhD studies.

Her research interests are at the border between computing systems and control theory. In the cloud control project, she is mainly working on control for software applications.

She is also involved with embedded systems research. Her research aims at decoupling the resource allocation and the application adaptation problem, lowering the complexity of both the application manager and the resource manager.

Magnusson, Fredrik

Ph.D. in Automatic Control. He defended his PhD thesis *Numerical and Symbolic Methods for Dynamic Optimization* in November and has since moved on to new and yet familiar frontiers.

He was a teaching assistant in the course Control Theory and also supervised labs in various other courses and also supervised a Master's thesis.

Mannesson, Anders

Lic. Tech., graduate student since June 2010. He joined the department after working 4 years as analog ASIC designer in the electronics industry. He is now working together with Prof. Bo Bernhardsson on improving positioning, radio channel estimates, and link adaptation within the ELLIIT project. His main research topics involves estimation, statistical signal processing, and optimization.

In May he defended his PhD thesis called *Joint Positioning and Multipath Radio Channel Estimation and Predication*.

Martins, Alexandre

Industrial PhD since April 2016.
Committed in the WASP project.

Mejvik, Jacob

PhD Student since November. Trying to figure out my research interests.

He will be involved in the LISA2 project with Charlotta Johnsson as main supervisor. He also attended meetings for the SysInt project with intention to specify future projects.

He has been a Lab assistant at the basic course for CMN.

Millnert, Victor

PhD student at the department since September 2014. Research focus is on cloud computing, and during 2016 emphasis has been on controlling virtualized network functions in a forwarding graph. This has involved collaboration with Enrico Bini at the University of Turin.

Teaching duties has involved aiding in the course development of "Network Dynamics" as well as teaching in "Applied Robotics" and "Automatic Control, Basic Course".

During 2016 he was accepted as an affiliated PhD student in the Wallenberg Autonomous Software and Systems Program (WASP).

Nayak Seetanadi, Gautham

Msc in Integrated Circuit Design. Gautham is currently a PhD student since January 2016 after a short stint as a research assistant at the

department. His main research interests are on feedback control for cyber-physical systems. His current project focuses on feedback based image quality control and intelligent bandwidth distribution to networks of cameras. He has visited the faculty of engineering in Porto for research collaboration.

He is also involved in teaching at the department having taught the basic course and the systems engineering course during multiple semesters. He has also supervised the project *In process control course*.

Nilsson, Anders

PhD (2006), Research Engineer since 2010. Spends most of the time looking after the department computers and their software.

With a past at the department of computer science developing compiler and runtime system for real-time Java, he also tries to squeeze in some time for research. Recently this has meant being involved in the EU FP7 SMERobotics project, trying to use compiler technology knowledge and tools for managing formal knowledge and ontologies with the goal to make industrial robots easier to use.

Nilsson, Gustav

MSc in Engineering Physics (2013). Gustav has been a PhD student at the department since September 2013.

His research interests are modeling and distributed control of large scale systems with applications in traffic networks. For the moment he is focusing on traffic light control.

During the fall, he has made a couple of two weeks visits to Dipartimento di Scienze Matematiche "Giuseppe Luigi Lagrange", Politecnico di Torino, Italy.

During the year, he has been involved in the teaching and development of the master's level course in Network Dynamics and he was also one of the lecturers in the Basic Control Course given at Zhejiang University, China.

Nilsson, Ingrid

Finance officer at the department since 2009. Ingrid is mainly responsible for the financial transactions at the department such as book-keeping, budget managing and balancing of the books. Another big task is administration of research projects and reporting to the sponsors.

Nishimura, Mika

Born in Japan. Administrator at the department since 2014. She handles student registration and exam results in Ladok and also registers public journals at the department. She has contact with the printing office about doctoral thesis and other publications. She is responsible for the library, including updating in Libris, and archives and for purchase of office supplies, books and furniture. She updates parts of the web pages and keeps keys in order among other service-oriented tasks.

She also teaches Japanese at Folkuniversitetet in Lund since 2006.

Nylander, Tommi

MSc in Engineering Physics. PhD student since January 2016.

He is part of the WASP Autonomous Cloud research project, focusing on control-based resource management.

During the year he has also taken some courses and been a teaching assistant in the basic control course as well as in the Systems Engineering/Process Control course.

Olofsson, Björn

Ph.D. in Automatic Control, employed at the department since August 2010. He defended his Ph.D. Thesis, *Topics in Machining with Industrial Robot Manipulators and Optimal Motion Control*, in September 2015.

During the year, he has been involved in a research project for high-precision temperature stabilization of the phase-reference distribution system at ESS.

He has also taken active part in the teaching at the department, both within the undergraduate engineering programs and by supervision of Master Thesis projects.

Pates, Richard

Postdoctoral researcher at the department since 2015.

His principal research interests are in how to design of decentralised controllers in networks using only local model information. A typical example would be how to design a voltage regulator in a power plant with little or no information about the electrical power system to which it is connected.

Last year he was also involved in teaching the Linear Systems Course.

Perninge, Magnus

As a researcher his research interests are: Power system stability and control, stochastic control, operations research. He is working in the project *A Stochastic Control Approach to Optimal Power System Operation*, funded by the Swedish Research Council.

Rantzer, Anders

Professor of Automatic Control since 1999 and coordinator of the Linnaeus center LCCC since the start 2008. He has broad interests in modeling, analysis and synthesis of control systems, with particular attention to robustness, optimization and distributed control.

Anders Rantzer is the main supervisor for several PhD students and postdocs. He spent September 2015 to May 2016 as visiting researcher and coorganizer of a Annual Thematic Program on Control Theory at Institute for Mathematics and Its Applications, University of Minnesota.

In the autumn of 2016, he was teaching the course "FRTN05 Nonlinear Control and Servo Systems".

Rasmusson, Monika

Financial administrator at the department since August 2011. As a part of the administrative team, her work includes reimbursements, travel bills, reporting projects, involvement in the budgetprocess among other tasks.

Robertsson, Anders

Professor (2012), Associate professor (2007), "Docent" (2005), Research Associate (May 2003), PhD (1999). Excellent Teaching Practitioner (ETP) in 2007. His main interests are in nonlinear control, robotics and control of computing systems.

Currently he is working on parallel kinematic robots, sensor-data integration and force control of industrial robots in collaboration with ABB Robotics/ABB CRC. The research has been conducted with the LUCAS project, the Robotics Lab, The Linneaus Centre LCCC, ELLIIT network, and the EU funded projects SaraFUN (H2020), SMERobotics (FP-7), and Flexifab (FP-7). He has also been doing research on admission control in network nodes and control of server systems in cooperation with the Department of Electrical and Information Technology, LTH, Lund University and within the VR-funded CloudControl-project together with Umeå University.

He has been teaching in the courses on Applied Robotics (MMKF15) and Project course on Automatic Control (FRT090), and been supervisor for several project groups in mechatronics, electronics and participated in the teacher education at Vattenhallen, LTH.

He has acted as advisor/co-advisor for (1+5) PhD students and several Master's Thesis project.

Rönn (Stemann), Meike

Lic. Tech., graduate student since November 2009. She is working together with Anders Rantzer on control of energy usage in buildings, within the eLLIIT project. Within this project, she is looking at the possibilities of improving temperature regulation and occupant comfort by using PID control and decoupling networks.

In June 2016, she defended her PhD thesis called *Glycemic Control and Temperature Control in Buildings*.

Sadeghi, Hamed

Hamed has received his MSc (2013) and BSc (2011) in Mechanical Engineering from Sharif University of Technology in Iran. He is a PhD student at the Automatic Control Department, since August 2016.

His research interests are in control theory with focus on distributed estimation, control and optimization, as well as application of control theory to traffic and transportation systems. His research is a part of the WASP project.

He has completed several courses and been teaching assistant for the Automatic Control basic course during fall 2016.

Skarin, Per

Per is an industrial PhD student from Ericsson research and part of the Wallenberg Autonomy and Software Program, called WASP.

He has been active since August 2016 and will do research within the Autonomous Cloud. His first six months have been mostly focused on the newly started Wallenberg ASP with a broad course on autonomous systems and an international study trip to visit universities and companies in Zürich and Munich. A small feat was accomplished when his team scored first place in the peer reviewed challenge on autonomous systems setup within the Wallenberg ASP Graduate School.

Soltesz, Kristian

Kristian started a two year post doc in February 2015, of which parts were spent with Sigurd Skogestad's group at the Norwegian University of Science and Technology (NTNU), Trondheim, Norway.

His research is in control of biomedical systems, and automatic controller tuning.

During 2016 Kristian has worked on hemodynamic stabilization of potential organ donors, in collaboration with thoracic surgery researchers,

within a Vinnova-financed research project. He has also co-authored works on robust controller synthesis under parametric uncertainties, in collaboration with visiting PhD student Pedro Mercader from the University of Murcia, Spain.

Kristian is the co-supervisor of two PhD students, and has been involved in supervising students at the University of British Columbia, Vancouver, Canada, and the Karolinska Institute, Stockholm, Sweden.

Kristian has been responsible for the Automatic Control basic course, given as part of a Lund University programme at Zhejiang University, Hangzhou, China. He has also been involved as supervisor of master thesis projects, and of project courses in electronic system development, and clinical innovations, at Lund University.

Sörnmo, Olof

Late 2015, Olof finalized and defended his thesis *Adaptation and Learning for Manipulators and Machining*.

During 2016 he was engaged in a special project to be completed in time for the Automatica fair in Munich.

Thelander Andrén, Marcus

MSc in Engineering Physics (2015), and a PhD student at the department since August 2015.

His main research interests are event-based control and estimation.

During 2016 he presented work on event-based estimation using stochastic triggering at EBCCSP 2016, Kraków, Poland.

He has been a teaching assistant and lab supervisor in the courses in Basic Control and Multivariable Control. He has also supervised projects in the Control Project Course.

Troeng, Olof

MSc (2012). PhD student since Oct 2014, working on accelerating field control (LLRF) for the linear accelerator at the European Spallation Source.

During the year he has analyzed different aspects of the control problem, designed

firmware algorithms, presented at specialized conferences and contributed to a successful critical design review of the LLRF system.

Olof has been a teaching assistant in the multivariable control course and given lectures in the introductory control course given at Zhejiang University, China.

Westin, Eva

PhD in French linguistics.

Administrator at the department since 2008 and administrative coordinator from 2012.

She has the overall responsibility of human resources, guests and conferences. She also handles part of the process for research studies.

Eva is the project administrator for the LCCC Linnaeus project. She is part of the workplace health and safety team at the department. She is also part of the Equality group at the Faculty of Engineering and works with these questions at the Department.

Wittenmark, Björn

He joined the department in 1966 and took his PhD in 1973. He became full professor at the department 1989. His main research interests are adaptive control, sampled-data systems, and process control. He is emeritus professor at the department since 2010.

During the spring 2016 he gave the PhD course Stochastic Control at the department.

Xu, Yang

MSc in Automatic Control. PhD student since June 2012.

Yang's main research interests involve integrated scheduling and synthesis of networked embedded event-based control systems. He is involved in the ELLIIT project.

He was a teaching assistant in Automatic Control course, in Lund University and Zhejiang University.



Automatic Control meeting in Gothenburg, June 2016.

PROMOTING GENDER EQUALITY AND DIVERSITY

The working group on gender equality and diversity was formed in early 2014. Since the start we have had some 15 seminars by invited speakers on subjects ranging from research communication and security at the university, to work ergonomics and how to implement diversity at one's workplace. We have also been visited by the LGBT network (HBTQ in Swedish), as well as the health care and staff units for employees at Lund University. The seminars have made issues on gender equality and diversity a natural talking point during our coffee breaks, which we believe

is crucial for improving and tackling such issues. Besides the seminar series, we have organized a lunch for master's thesis students and their supervisors, with the purpose of creating a platform for companies and students interested in control to meet, as well as for us to introduce the work we do at the department. The lunch was very well received, and we plan to arrange it again in 2017. In 2016 we welcomed Victor Millnert and Martina Maggio in to the group, to replace the outgoing members Olof Sörnmo and Tore Hägglund. Together with Eva Westin and Carolina Lidström, they will help to continue to make the JäLM-group a success in 2017.



AWARDS

GRANTS

Best Paper award

Morteza Mohaqeqi, Mitra Nasri, Yang Xu, Anton Cervin, and Karl-Erik Årzén received the Best Paper Award for the paper, *On the Problem of Finding Optimal Harmonic Periods*, presented at the 24th International Conference on Real-Time Networks and Systems (RTNS 2016).

Best Paper award

Michelle Chong received best paper award at the 2016 ACM/IEEE 7th International Conference on Cyber-Physical Systems for *SMT-based observer design for cyber-physical systems under sensor attacks*.

Best Paper award

Martina Maggio received best paper award at the 22nd IEEE international conference on embedded and real-time computing systems and applications (RTCSA 2016) for *A Tool for Measuring Supply Functions of Execution Platforms*.

Grant from Foundation

Kristian Soltesz received a grant from "Hans-Gabriel och Alice Trolle-Wachtmeisters Stiftelse för Medicinsk Forskning" i.e Hans-Gabriel and Alice Trolle-Wachtmeister's Foundation for Medical Research.

Grant from Knut och Alice Wallenberg Foundation

Giulia Giordano received a travel grant to support her stay in California in December 2016, to foster research collaborations with Elisa Franco (UC Riverside) and Vanessa Jonsson (City of Hope National Medical Center).

Outstanding IEEE TAC Reviewer

Giulia Giordano received an Outstanding TAC Reviewer letter for her contribution as a reviewer for the IEEE Transactions on Automatic Control in the year 2016.

Process Automation Hall of Fame

Charlotta Johnsson was elected into the Process Automation Hall of Fame in April 2016. The award has the criteria excellence, diligence and influence to the process control industry.

TechTransfer finalist

Anders Robertsson was a Finalist at the euRobotics 2016 TechTransfer, March 21, 2016.

ASSIGNMENTS

BOARD MEMBER

Årzén, Karl-Erik

Vice Chairman of the Board for the ELLIIT strategic research area project.

Member of the Program Management Group for the Wallenberg Autonomous Systems Program (WASP).

Member of the Strategic Management Board for the EMSIG Special Interest Group on Embedded Systems.

Member of Research Board for the Faculty of Engineering, Lund University.

Treasurer and Member of the Executive Committee for the IEEE Computer System's Technical Committee on Real-Time Systems (TCRTS).

Como, Giacomo

Board Member of LCCC and of the Department of Automatic Control. He has served as main supervisor of Gustav Nilsson and co-supervisor of Hamed Sadeghi and Martin Heyden.

Johnsson, Charlotta

Board member at PTW at Höskolan Väst, Trollhättan, Sweden.

Board member at SESAM-Sverige, a network for industrial automation.

Board member at SmartFactory TU Kaiserslautern, Germany.

Hägglund, Tore

Expert member in legal proceedings for patent at Svea Court of Appeal.

Rantzer, Anders

Member of the steering committee for the International Symposium on Mathematical Theory of Networks and Systems.

Member of Editorial Board for the Springer Journal Annual Reviews in Control.

Member of Editorial Board for Proceedings of the IEEE.

Robertsson, Anders

Member of the Steering Committee and the Program Committee of Feedback Computing 2016.

Wittenmark, Björn

Board member of the research program PIC-LU.

Member of the research board of Gyllenstiernska Krapperupsstiftelsen.

MEMBER OF INTERNATIONAL PROGRAM COMMITTEE (IPC)

Årzén, Karl-Erik

Member of the Program Committee for the 22nd IEEE Real-Time and Embedded Technology and Applications Symposium, (RTAS 2016), Vienna, Austria.

Finance Chair for the Real-Time Systems Symposium (RTSS), Porto, Portugal, Nov 29 - Dec 2, 2016
Co-Chair for the topic Cyber-Physical Systems for DATE 2016 (Design, Automation & Test in Europe), Grenoble, France, March 14-18, 2016.

Member of the Program Committee for the 2016 IEEE International Conference on Cloud and Autonomic Computing (ICCAC), Augsburg, German, Sep 12-16, 2016.

Member of the Program Committee for the ACM/IEEE 7th International Conference on Cyber-Physical Systems (ICCPS), Vienna, Austria, April 11-14, 2016.

Member of the Program Committee for the 1st IEEE International Conference on Internet-of-Things Design and Implementation, Berlin, Germany, April 4-8, 2016.

Member of the Program Committee for EMSOFT 2015 (The 16th ACM SIGBED International Conference on Embedded Software), Seoul, South Korea, Oct 15-20, 2016.

Cervin, Anton

Member of the IPC for the 27th Euromicro Conference on Real-Time Systems, Lund, Sweden.

Member of the IPC for the 2nd International Conference on Event-Based Control, Communication, and Signal Processing, Krakow, Poland.

Hägglund, Tore

Member of committee of 21st IEEE International Conference on Emerging Technologies and Factory Automation, EFTA 2016, Berlin, Germany

Johansson, Rolf

Member of Advisory Committee, IEEE BioRob 2016, IEEE International Conference on Biomedical-Robotics and Biomechanics (BioRob2016), Singapore, June 26-29, 2016; Sponsored by IEEE Robotics and Automation Society & IEEE Engineering in Medicine and Biology Society.

Associate Editor of IEEE International Conference on Robotics and Automation (ICRA2016), May 16-21, 2016, Stockholm, Sweden.

IPC member for the 8th IFAC Symposium Advances in Automotive Control (AAC 2016), Jun 19-23, 2016, Kolmården Wildlife Resort, Norrköping, Sweden.

IPC member for the IFAC International Workshop on Adaptation and Learning in Control and Signal Processing (IFAC ALCOSP 2016), June 29 - July 1, Eindhoven, The Netherlands.

Member of Senior Program Committee of IEEE/RSJ International Conference on Intelligent Robots and Systems (IROS2016), Oct 9 to 14, 2016, Daejeon, Korea.

Rantzer, Anders

Chairman of the IPC for European Control Conference, Ålborg, 2016.

OPPONENT AND MEMBER OF EXAMINATION COMMITTEE

Årzén, Karl-Erik

External examiner for the PhD thesis of Mason Thammawichai, Department of Aeronautics, Imperial College London, UK, May 9, 2016.

Member of the PhD thesis committee for Amir, Aminifar, Department of Computer Science, Linköping University, March 22, 2016.

Bernhardsson, Bo

Deputy member of the examination committee for Waqas Ahmed, EIT, Lund University

Deputy member of the examination committee for Johan Fredriksson, Math, Lund University.

Cervin, Anton

Member of the PhD examination committee of Christian Andersson, Div. of Numerical Analysis, Lund University, May 4.

Chong, Michelle

Reserve member of the PhD Examination Committee for Meike Rönn.

Como, Giacomo

He served as opponent at the School of Electrical Engineering of the Royal Institute of Technology (KTH), November 2016.

Giselsson, Pontus

Member of Mariette Annergren's PhD Thesis Examination Committee at KTH, Stockholm, Sweden. September 2nd, 2016.

Hägglund, Tore

Member of the evaluation committee for the PhD thesis by Yujiao Song, Chalmers university of technology, Sweden, "On the robust stability analysis of VSC-HVDC systems", December 8.

Johnsson, Charlotta

Member of the evaluation committee for the PhD thesis by Niklas Fors, Dept of Computer Science, Lund University, Sweden, *The Design and Implementation of Bloqqi - A Feature-Based Diagram Programming Language*, October 21, 2016.

Rantzer, Anders

Member of Examination Committee for Milan Korda, EPFL, PhD dissertation Lausanne, April 27, 2016.

Member of Examination Committee for Azita Dabiri, Chalmers, PhD dissertation, Gothenburg, September 9, 2016.

Robertsson, Anders

Member of Assessment Committee for PhD student Thomas Timm Andersen, Technical University of Denmark (DTU), Lyngby, May 23, 2016.

Member of Examination Committee for Torstein Anderssen Myhre; *Vision-Based Control of a Robot Interacting with Moving and Flexible Objects*, NTNU, Trondheim, Norway, April 20, 2016.

ADVISORY COMMITTEES AND WORKING GROUPS

Årzén, Karl-Erik

Member of the Norwegian committee on assessment of competence for the title of full professor in IT.

Co-Chair for the Panel on Signals and Systems, Swedish Research Council.

Member of the Royal Swedish Academy of Engineering Sciences (IVA).

Chairman of IVA South - the Southern Sweden branch of the Royal Swedish Academy of Engineering Sciences.

Johansson, Rolf

Member of IEEE EMBS Technical Committee (TC) for Biomedical Robotics.

Member of Joint EMBS/RAS Advisory Committee on Biorobotics.

Member of International Advisory Board for the project consortium SFI Offshore Mechatronics, Norway Research Council & Norwegian Offshore and Drilling Engineering (NODE).

Member of the NTNU International Evaluation Committee for Assessment of the PhD Programmes, NTNU, Faculty of Information Technology, Mathematics and Electrical Engineering, Trondheim, Norway

Johnsson, Charlotta

Member in SIS's Strategic Advisory Group for Industry 4.0/Smart Manufacturing.

Member in SIS and SEK and serves as the Swedish expert in the international IEC 62264 and ISO 22400 standards.

Voting member in the standardisation committee ISA95 and an information member in the standardization committees ISA88 and ISA99.

Rantzer, Anders

Member of the Advisory Board for Lecture Notes in Control and Information Sciences at Springer Verlag Heidelberg.

Member of the IEEE Control System Society Technical Committee on Nonlinear Systems and Control.

Member of the IFAC Technical Committee on Nonlinear Systems.

Member of the organizing committee for the IMA Thematic Program 2015/16 on *Control Theory and its Applications*.

OTHER ASSIGNMENTS

Årzén, Karl-Erik

Associate Editor for Real-Time Systems Journal.

Area Editor for the Leibniz Transactions on Embedded Systems (LITES).

Associate Editor for ACM Transactions on Cyber-Physical Systems.

Berner, Josefin

Member of the research education council at LTH since May 2016.

Como, Giacomo

Editorial Board of the IEEE Transactions on Control of Network Systems.
Editorial Board of the IEEE Transactions on Network Science and Engineering.

Johansson, Rolf

Editor, Mathematical Biosciences, (Elsevier).
Associate Editor, International Journal of Adaptive Control and Signal Processing, (Wiley).
Associate Editor, Chinese Journal of Scientific Instrument, (China Instrument and Control Society).
Member of Editorial Board, Robotics and Biomimetics, (Springer).
Editor, Intelligent Service Robotics (ISR), Springer.

Hägglund, Tore

Editor for Control Engineering Practice.

Maggio, Martina

Journal Editor: Associate Editor for the ACM Transaction on Embedded Systems, in the specific area of Self-Aware/Self-Adaptive Computing.

Westin, Eva

Representative for Automatic Control in and member of the Equality group (JäLM) at the Faculty of Engineering.

LONGER VISITS ABROAD**Bagge Carlson, Fredrik**

Lecturer in Automatic Control, basic course, at Zhejiang University, Hangzhou, China, during the fall 2016.

Berner, Josefin

On leave of absence during January-February, doing some voluntary work in El Salvador.

Como, Giacomo

Visiting scholar at the Institut Henry Poincaré in Paris, February-March 2016.
On leave at the Lagrange Department of Mathematical Sciences of Politecnico di Torino since September 2016.

Lidström, Carolina

Visiting student at the Institute for Mathematics and its Applications, University of Minnesota, Minneapolis, USA, in May 2016.

Nilsson, Gustav

Lecturer in Automatic Control, basic course, at Zhejiang University, Hangzhou, China, November 2016.

Pates, Richard

Visiting student at the Institute for Mathematics and its Applications, University of Minnesota, Minneapolis, USA, in May 2016.

Soltész, Kristian

Responsible for the Automatic Control basic course, given as part of a Lund University programme at Zhejiang University, Hangzhou, China, November 2016.

Troeng, Olof

Lecturer in Automatic Control, basic course, at Zhejiang University, Hangzhou, China, December 2016.

Economy

This chapter contains an overall view of the economy and funding

ECONOMY

The turnover for 2016 was 57 MSEK, an increase by 4 MSEK since 2015. About half of the income, 49%, comes from Lund University, and the rest, 51%, from external grants. The distribution is shown below.

The activity and the number of employees seem to have stabilized during the last years, the number of employees has been about the same during the last five years. The department participated in three projects funded by the European Union, EU, during 2016. The Swedish Foundation for Strategic Research (SSF) and Swedish Research Council (VR), have also provided substantial support of the activities.

The block grants from VR and some of the SSF projects are long range. Several projects do, however, have a duration of only two years. To match these with the length of a PhD position, i.e. 5 years, we have a long-term internal research planning, and we are careful to bid on projects that fit into our research plan. This has proven efficient to match short-term funding, research planning and personnel.

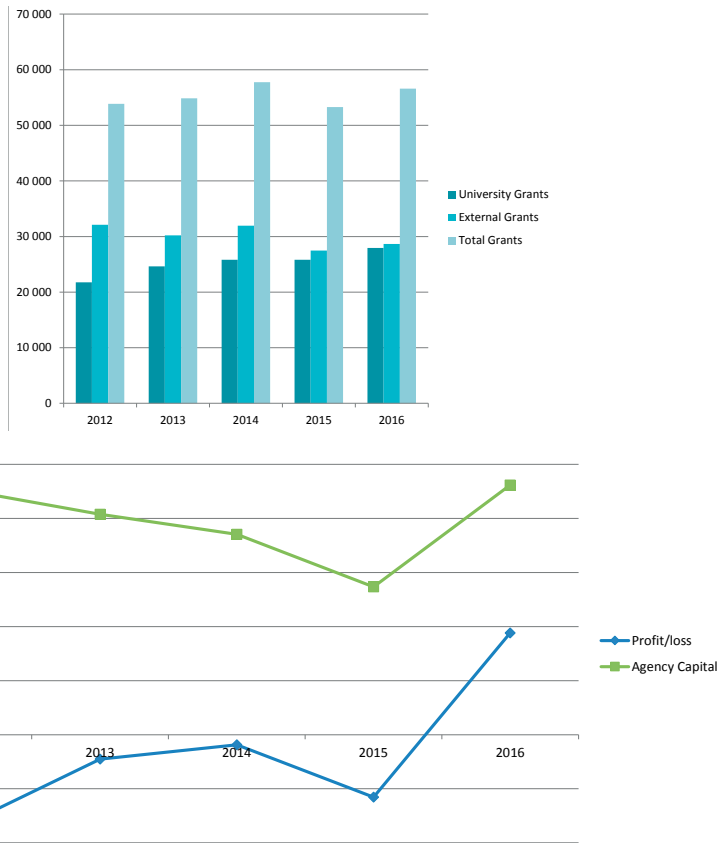

Above: Profit/loss and Agency Capital development over the last 5 years

FUNDING

During 2016 we had the following grants:

- VR – Linnaeus grant Lund Center for Control of Complex Engineering Systems LCCC
- VR – Information Dynamics over large-scale networks
- VR – Feedback Based Resource Management for Embedded Multicore Platforms
- VR – Simultaneous Movement Tracking and Radio Channel Estimation
- VR – Event-based control components with performance bounds
- VR – Active Control of Compressor Systems Based on New Methods of Nonlinear Dynamic Feedback Stabilization
- VR – Scalable and Resource-Constrained Control Systems
- VR – Cloud Control
- VR – Remuneration for Anders Rantzers' function as a Member of the Scientific Council for Natural and Engineering Sciences within the Swedish Research Council 2013-2015
- VR – Power and temperature control for large-scale computing infrastructures
- VR – Methods for control of large-scale dynamical systems
- VR – Stokastisk reglering för optimal drift av elkraftsystem
- VR – Reglering i cyberfysiska system
- VR – Resilient control of dynamical network flows
- Energimyndigheten - Predictive Control and System Optimisation of Wheel Loaders
- Vinnova – Line Information System Architecture, LISA
- Vinnova – Line Information System Architecture 2, LISA2
- Vinnova – PiiA-Nyckeltal i svensk processindustri (PiiA-Metrics)
- Vinnova – Automatinställande Industriell Reglering - PiiAuto
- Vinnova – Hemodynamisk stabilisering
- Vinnova – Den digitaliserade process industrin (Dig-PI)
- Vinnova - UDI, Kirurgens perspektiv, en 3 D bildplattform för kirurgisk utbildning och utveckling av robotkirurgi
- Vinnova - Systemintegration av heterogen utrustning för produktivitet inom Industri-4.x (SysInt4.x)
- Vinnova – Aktiv kvotreglering
- Vinnova – Mot en trådlös intensivvård
- SSF – ICT platform for lasting infrastructure, ICT-PSI
- SSF /ICA – Algoritmer och verktyg för realtidsoptimering
- SSF – Storskaliga cyber-fysiska transportsystem
- SSF - Semantisk kartering & visuell navigering för smarta robotar
- EU – FP7 287787 The European Robotics Initiative for Strengthening the Competitiveness of SMEs in Manufacturing by integrating aspects of cognitive systems, SMERobotics
- EU – FP7-SME-2013-606156-FlexiFab – Flexible fabrication of lightweight aluminium transport structures, FlexiFab
- EU – Horizon 2020, GA 644938, Smart Assembly Robot with Advanced FUNctionalities – SARAFun
- KAW – Wallenberg Autonomous Systems and Software Program – WASP
- ESS – Temperature Control of Phase Reference Line
- The Linköping–Lund Initiative on IT and Mobile Communication, ELLIIT
- SKB - Control of Stirwelding Process for Sealing
- Emissions Control for Low Climate Impact, KCFP3

Appendix

This chapter contains a list of publications, seminars and lectures given outside the department during 2016

PUBLICATIONS 2016

You can find references to all the publications on www.control.lth.se/publications and almost all of them can be downloaded from this site. Any of the reports may, however, be borrowed through your library service or from the following libraries in Sweden:

- Göteborgs universitetsbibliotek
- Kungliga Biblioteket
- Linköpings universitetsbibliotek
- Lunds universitetsbibliotek
- Stockholms universitetsbibliotek
- Umeå universitetsbibliotek
- Uppsala universitetsbibliotek

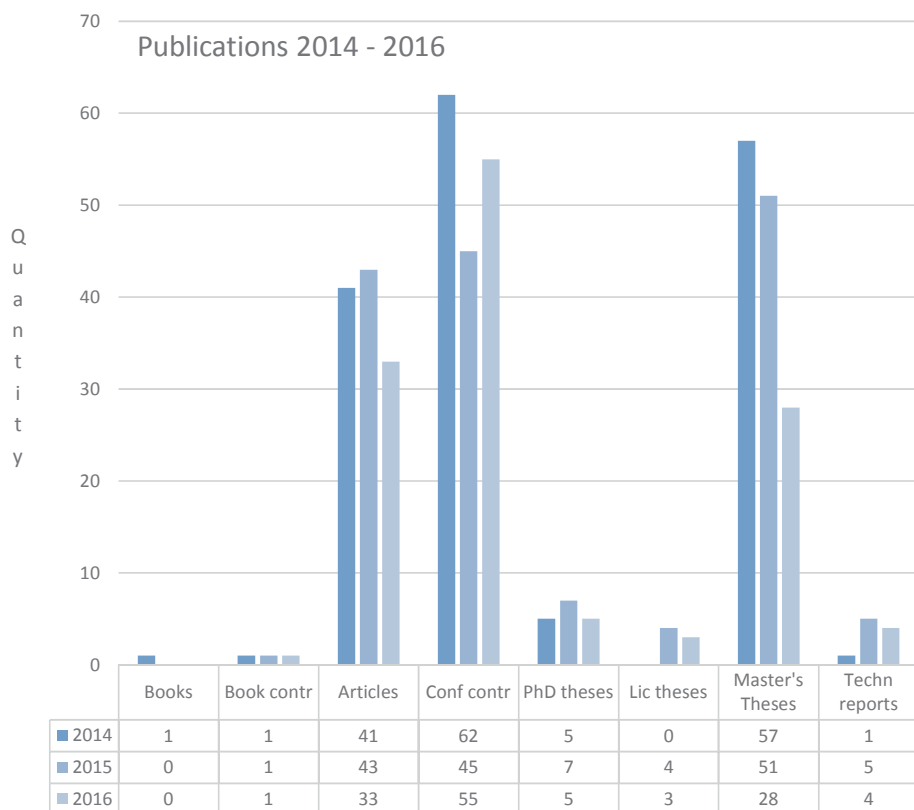

BOOK CONTRIBUTIONS

Johnsson, Charlotta; Nilsson, Carl-Henric; Kokaia, Givi; *Extended Flipped Classroom : using peer dynamics for integrative learning*; In Learning in Higher Education, Libri Publishing, 2016.

JOURNAL ARTICLES

Berner, Josefin; Häggglund, Tore; Åström, Karl Johan; *Asymmetric relay autotuning - Practical features for industrial use*; Control Engineering Practice, 54, pp. 231–245, 2016.

Berntorp, Karl; *Joint Wheel-Slip and Vehicle-Motion Estimation Based on Inertial, GPS, and Wheel-Speed Sensors*; IEEE Transactions on Control Systems Technology, 24:3, pp. 1020–1027, 2016.

Blanchini, Franco; Fenu, G.; Giordano, Giulia; Pellegrino, Felice Andrea; *Model-Free Plant Tuning*; IEEE Transactions on Automatic Control, PP:99, pp. 1–1, 2016.

Blanchini, Franco; Fenu, Gianfranco; Giordano, Giulia; Pellegrino, Felice Andrea; *A convex programming approach to the inverse kinematics problem for manipulators under constraints*; European Journal of Control, 2016.

Chasparis, Georgios; Maggio, Martina; Bini, Enrico; Årzén, Karl-Erik; *Design and Implementation of Distributed Resource Management for Time Sensitive Applications*; Automatica, 64, pp. 44–53, 2016.

Como, Giacomo; Fagnani, Fabio; *From local averaging to emergent global behaviors : The fundamental role of network interconnections*; Systems & Control Letters, 96, pp. 70–76, 2016.

De Coninck, Roel; Magnusson, Fredrik; Åkesson, Johan; Helsen, Lieve; *Toolbox for development and validation of grey-box building models for forecasting and control*; Journal of Building Performance Simulation, Taylor & Francis, 9:3, pp. 288–303, 2016.

Ghazaei, Mahdi; Khong, Sei Zhen; Bernhardsson, Bo; *On the Convergence of Iterative Learning Control*; Automatica, 2016.

Giordano, Giulia; Blanchini, Franco; Franco, Elisa; Mardanlou, V.; Montessoro, P.L.; *The Smallest Eigenvalue of the Generalized Laplacian Matrix, with Application to Network-Decentralized Estimation for Homogeneous System*; IEEE Transactions on Network Science and Engineering, 3:4, pp. 312–324, 2016.

Gusev, Sergey; Paramonov, Leonid; Pchelkin, Stepan; Robertsson, Anders; Freidovich, Leonid; Shiriaev, Anton S.; *Modification of a PD+ controller for the orbital stabilization of the motions of an all-wheel drive mechanical system*; Journal of Applied Mathematics and Mechanics, 79:6, pp. 546–555, 2016.

Hamon, Camille; Perninge, Magnus; Soder, Lennart; *An importance sampling technique for probabilistic security assessment in power systems with large amounts of wind power*; Electric Power Systems Research, 131, pp. 11–18, 2016.

Holmqvist, Anders; Magnusson, Fredrik; *Open-loop optimal control of batch chromatographic separation processes using direct collocation*; Journal of Process Control, 46, pp. 55–74, 2016.

Ingesson, Gabriel; Yin, Lianhao; Johansson, Rolf; Tunestål, Per; *Evaluation of Nonlinear Estimation Methods for Calibration of a Heat-Release Model*; SAE International Journal of Engines, 125:3, 2016.

Ingesson, Gabriel; Yin, Lianhao; Tunestål, Per; Johansson, Rolf; *An Investigation on Ignition Delay Modeling For Control*; International Journal of Powertrains, 2016.

Johansson, Rolf; Robertsson, Anders; Shiriaev, Anton; *Observer-based strictly positive real (SPR) variable structure output feedback control*; Journal of the Franklin Institute, 353:16, pp. 4213–4232, 2016.

Johnsson, Charlotta; Nilsson, Carl-Henric; Kleppestø, Stein; *Technology Management: a cross-disciplinary master program with a focus on Leadership*; Engineering Management Research, 5:2, pp. 40–46, 2016.

- Johnsson, Charlotta; Loeffler, Rebecca; Sidhu, Ikhtlaq; Nilsson, Carl-Henric; *A Student-Centered Approach and Mindset-Focused Pedagogical Approach for Entrepreneurship and Leadership*; Applied Innovation Review, pp. 57–63, 2016.
- Khong, Sei Zhen; Lovisari, Enrico; Rantzer, Anders; *A Unifying Framework for Robust Synchronization of Heterogeneous Networks via Integral Quadratic Constraints*; IEEE Transactions on Automatic Control, 61:5, pp. 1297–1309, 2016.
- Leva, Alberto; Terraneo, Federico; Rinaldi, Luigi; Papadopoulos, Alessandro V.; Maggio, Martina; *High-Precision Low-Power Wireless Nodes' Synchronization via Decentralized Control*; IEEE Transactions on Control Systems Technology, 24:4, pp. 1279–1293, 2016.
- Madjidian, Daria; Mirkin, Leonid; Rantzer, Anders; *H2 Optimal Coordination of Homogeneous Agents Subject to Limited Information Exchange*; IEEE Transactions on Automatic Control, 2016.
- Mannesson, Anders; Yaqoob, Muhammad Atif; Bernhardsson, Bo; Tufvesson, Fredrik; *Tightly Coupled Positioning and Multipath Radio Channel Tracking*; IEEE Transactions on Aerospace and Electronic Systems, pp. 1522–1535, 2016.
- Olofsson, Björn; Bergstedt, Jacob; Kortier, Henk G.; Bernhardsson, Bo; Robertsson, Anders; Johansson, Rolf; *Sensor Fusion for Robotic Workspace State Estimation*; IEEE/ASME Transactions on Mechatronics, 21:5, pp. 2236–2248, 2016.
- Papadopoulos, Alessandro Vittorio; Bascetta, Luca; Ferretti, Gianni; *Generation of human walking paths*; Autonomous Robots, 40:1, pp. 59–75, 2016.
- Papadopoulos, Alessandro Vittorio; Ali-Eldin, Ahmed; Årzén, Karl-Erik; Tordsson, Johan; Elmroth, Erik; *PEAS: A Performance Evaluation Framework for Auto-Scaling Strategies in Cloud Applications*; ACM Transactions on Modeling and Performance Evaluation of Computing Systems, 2016.
- Papadopoulos, Alessandro Vittorio; Klein, Cristian; Maggio, Martina; Dürango, Jonas; Dellkrantz, Manfred; Hernandez-Rodriguez, Francisco; Elmroth, Erik; Årzén, Karl-Erik; *Control-Based Load-Balancing Techniques: Analysis and Performance Evaluation via a Randomized Optimization Approach*; Control Engineering Practice, 52:July, pp. 24–34, 2016.
- Rantzer, Anders; *On the Kalman-Yakubovich-Popov Lemma for Positive Systems*; IEEE Transactions on Automatic Control, 61:5, pp. 1346–1349, 2016.
- Soltesz, Kristian; Grimholt, Chriss; Skogestad, Sigurd; *Simultaneous Design of PID Controller and Measurement Filter by Optimization*; IET Control Theory and Applications, 2016.
- Soltesz, Kristian; Mercader, Pedro; Baños, Alfonso; *An automatic tuner with short experiment and probabilistic plant parameterization*; Int. Journal of Robust and Nonlinear Control, pp. –, 2016.
- Soltesz, Kristian; Sturk, Christopher; Paskevicius, Audrius; Liao, Qiuming; Qin, Guangqi; Sjöberg, Trygve; Steen, Stig; *Closed-loop Prevention of Hypotension in the Heartbeating Brain-dead Porcine Model*; IEEE Transactions on Biomedical Engineering, pp. –, 2016.
- Sörnmo, Olof; Bernhardsson, Bo; Kröling, Olle; Gunnarsson, Per; Tenghamn, Rune; *Frequency-Domain Iterative Learning Control of a Marine Vibrator*; Control Engineering Practice, 47, pp. 70–80, 2016.
- Sörnmo, Olof; Olofsson, Björn; Robertsson, Anders; Johansson, Rolf; *Learning Approach to Cycle-Time-Minimization of Wood Milling Using Adaptive Force Control*; Journal of Manufacturing Science and Engineering, 138:1, 2016.
- Tärneberg, William; Mehta, Amardeep; Wadbro, Eddie; Tordsson, Johan; Eker, Johan; Kihl, Maria; Elmroth, Erik; *Dynamic application placement in the Mobile Cloud Network*; Future Generations Computer Systems, 2016.
- Theorin, Alfred; Bengtsson, Kristofer; Provost, Julien; Lieder, Michael; Johnsson, Charlotta; Lundholm, Thomas; Lennartson, Bengt; *An event-driven manufacturing information system architecture for Industry 4.0*; International Journal of Production Research, 2016.

CONFERENCE CONTRIBUTIONS

- Afzali-Far, Behrouz; Lidström, Per; Robertsson, Anders; *Dynamic isotropy in 3-DOF Gantry Tau robots - An analytical study*; In 2016 IEEE International Conference on Robotics and Automation, ICRA 2016.
- Angelopoulos, Konstantinos; Papadopoulos, Alessandro V.; Silva Souza, Vítor E.; Mylopoulos, John; *Model predictive control for software systems with CobRA*; In 11th International Symposium on Software Engineering for Adaptive and Self-Managing Systems, SEAMS 2016.
- Ba, Qin; Savla, Ketan; Como, Giacomo; *Distributed optimal equilibrium selection for traffic flow over networks*; In 54th IEEE Conference on Decision and Control, CDC 2015, 2016.
- Bagge Carlson, Fredrik; Karlsson, Martin; Robertsson, Anders; Johansson, Rolf; *Particle Filter Framework for 6D Seam Tracking Under Large External Forces Using 2D Laser Sensors*; In 2016 IEEE/RSJ International Conference on Intelligent Robots and Systems (IROS), 2016.
- Bauer, Margret; Lucke, Matthieu; Johnsson, Charlotta; Harjunkoski, Iiro; Schlake, Jan; *KPIs as the interface between scheduling and control*; In 11th IFAC Symposium on Dynamics and Control of Process Systems, 2016.
- Berner, Josefin; Häggglund, Tore; Åström, Karl Johan; *Improved Relay Autotuning using Normalized Time Delay*; In American Control Conference, 2016.
- Blanchini, Franco; Giordano, Giulia; *Structural analysis of dynamical networks: BDC-decomposition and influence matrix*; In Reglermöte 2016.
- Cervin, Anton; *LQG-Optimal PI and PID Control As Benchmarks for Event-Based Control*; In 2nd International Conference on Event-Based Control, Communication and Signal Processing, EBCCSP 2016.
- Como, Giacomo; Lovisari, Enrico; Savla, Ketan; *Convexity and Robustness of Dynamic Network Traffic Assignment for Control of Freeway Networks*; In 14th IFAC Symposium on Control in Transportation SystemsCTS 2016.
- Como, Giacomo; Lovisari, Enrico; Savla, Ketan; *Convex formulations of dynamic network traffic assignment for freeway networks*; In 53rd Annual Allerton Conference on Communication, Control, and Computing, Allerton 2015, 2016.
- Dürango, Jonas; Tärneberg, William; Tomas, Luis; Tordsson, Johan; Kihl, Maria; Maggio, Martina; *A control theoretical approach to non-intrusive geo-replication for cloud services*; In 55th IEEE Conference on Decision and Control, 2016.
- Giordano, Giulia; Rantzer, Anders; Jonsson, Vanessa; *A convex optimization approach to cancer treatment to address tumor heterogeneity and imperfect drug penetration in physiological compartments*; In 55th IEEE Conference on Decision and Control 2016.
- Giordano, Giulia; Bauso, Dario; Blanchini, Franco; *A saturated strategy robustly ensures stability of the cooperative equilibrium for Prisoner's dilemma*; In 55th IEEE Conference on Decision and Control 2016.
- Giordano, Giulia; Franco, Elisa; *Negative feedback enables structurally signed steady-state influences in artificial biomolecular networks*; In 55th IEEE Conference on Decision and Control 2016.
- Giselsson, Pontus; Fält, Mattias; Boyd, Stephen P.; *Line Search for Averaged Operator Iteration*; In Proceedings of the 55th IEEE Conference on Decision and Control, 2016.
- Giselsson, Pontus; *Tight linear convergence rate bounds for Douglas-Rachford splitting and ADMM*; In 54th IEEE Conference on Decision and Control, CDC 2015, 2016.
- Grussler, Christian; Rantzer, Anders; *On optimal low-rank approximation of non-negative matrices*; In 54th IEEE Conference on Decision and Control, CDC 2015, 2016.
- Grussler, Christian; Zare, Armin; Jovanović, Mihailo; Rantzer, Anders; *The use of the r^* heuristic in covariance completion problems*; In 55th IEEE Conference on Decision and Control 2016.

- Haage, Mathias; Profanter, Stefan; Kessler, Ingmar; Perzylo, Alexander; Somani, Nikhil; Sörnmo, Olof; Karlsson, Martin; Robertz, Sven; Nilsson, Klas; Resch, Ludovic; Marti, Michael; *On Cognitive Robot Woodworking in SMERobotics*; In International Symposium on Robotics, 2016.
- Imes, Connor; Kim, David H. K.; Maggio, Martina; Hoffmann, Henry; *Portable Multicore Resource Management for Applications with Performance Constraints*; In 10th IEEE International Symposium on Embedded Multicore/Many-core Systems-on-Chip 2016.
- Ingesson, Gabriel; Yin, Lianhao; Johansson, Rolf; Tunestål, Per; *Control of the low-load region in partially premixed combustion*; In Movic & Rasd 2016.
- Ingesson, Gabriel; Yin, Lianhao; Johansson, Rolf; Tunestål, Per; *A Double-Injection Control Strategy For Partially Premixed Combustion*; In 8th IFAC Symposium on Advances in Automotive Control AAC 2016.
- Johansson, Rolf; *Continuous-time model identification of time-varying systems using non-uniformly sampled data*; In 2016 IEEE Conference on Control Applications, CCA 2016.
- Johnsson, Charlotta; Suoranta, Mari; Sidhu, Ikhtlaq; Singer, Ken; *On using games for practicing entrepreneurial mindset*; In 11th European Conference on Innovation and Entrepreneurship, 2016.
- Johnsson, Charlotta; Nilsson, Carl-Henric; Kleppesø, Stein; *Learning Leadership : on including leadership training in higher education*; In American Society for Engineering Education 123rd Annual Conference, 2016.
- Karlsson, Martin; Karlsson, Fredrik; *Cooperative Indoor Positioning by Exchange of Bluetooth Signals and State Estimates Between Users*; In European Control Conference, 2016.
- Khong, Sei Zhen; Briat, Corentin; Rantzer, Anders; *Positive systems analysis via integral linear constraints*; In 54th IEEE Conference on Decision and Control, CDC 2015, 2016.
- Khong, Sei Zhen; Rantzer, Anders; *Diagonal Lyapunov functions for positive linear time-varying systems*; In 55th IEEE Conference on Decision and Control 2016.
- Li, Zheng; Tärneberg, William; Kihl, Maria; Robertsson, Anders; *Using a Predator-Prey Model to Explain Variations of Cloud Spot Price*; In 6th International Conference on Cloud Computing and Services Science, CLOSER 2016.
- Lidström, Carolina; Rantzer, Anders; *Optimal H-infinity state feedback for systems with symmetric and Hurwitz state matrix*; In American Control Conference, 2016.
- Lidström, Carolina; Rantzer, Anders; Morris, Kirsten; *H-infinity optimal control for infinite-dimensional systems with strictly negative generator*; In 55th IEEE Conference on Decision and Control, 2016.
- Maggio, Martina; Lelli, Juri; Bini, Enrico; *A Tool for Measuring Supply Functions of Execution Platforms*; In 22nd IEEE International Conference on Embedded and Real-Time Computing Systems and Applications, RTCSA 2016.
- Mercader, Pedro; Soltesz, Kristian; Banos, Alfonso; *PID synthesis under probabilistic parametric uncertainty*; In 2016 American Control Conference, ACC 2016.
- Mercader, Pedro; Soltesz, Kristian; Baños, Alfonso; *Autotuning of an In-Line pH Control System*; In 21st IEEE International Conference on Emerging Technologies and Factory Automation, ETFA, 2016.
- Mohaqqi, Morteza; Nasri, Mitra; Xu, Yang; Cervin, Anton; Årzén, Karl-Erik; *On the Problem of Finding Optimal Harmonic Periods*; In International Conference on Real-Time Networks and Systems, 2016.
- Nilsson, Gustav; Hosseini, Pouyan; Como, Giacomo; Savla, Ketan; *Entropy-like Lyapunov Functions for the Stability Analysis of Adaptive Traffic Signal Controls*; In The 54th IEEE Conference on Decision and Control, 2016.
- Nishimura, Mika; A Poster for the Jubilee of Master's Theses at Automatic Control; 2016.

- Nylén, Anders; Henningsson, Maria; Cervin, Anton; Tunestål, Per; *Control Design Based on FMI: A Diesel Engine Control Case Study*, In 8th IFAC Symposium Advances in Automotive Control, AAC 2016.
- Papadopoulos, Alessandro Vittorio; Maggio, Martina; *Virtual Machine Migration in Cloud Infrastructures: Problem Formalization and Policies Proposal*, In 54th IEEE Conference on Decision and Control, 2016.
- Perninge, Magnus; Eriksson, Robert; *A stochastic control formulation of the continuous-time power system operation problem*, In 2016 IEEE 16th International Conference on Environment and Electrical Engineering, 2016.
- Rantzer, Anders; *Exchange economics as an alternative to distributed optimization*, In 55th IEEE Conference on Decision and Control 2016.
- Rodrigo, Vicenr; Chioua, Moncef ;Hägglund, Tore; Hollender, Martin; *Causal analysis for alarm flood reduction*, In IFAC Symposium on Dynamics and Control of Process Systems (DYCOPS) 2016.
- Shiriaev, Anton; Freidovich, Leonid; Robertsson, Anders; Andersson, Alina; Johansson, Rolf; *Sufficient Conditions for Dynamic Stabilization of 3-State Moore-Greitzer Compressor Model*, In IEEE 54th Annual Conference on Decision and Control (CDC), 2016.
- Shoukry, Yasser; Chong, Michelle; Wakaiki, Masashi; Nuzzo, Pierluigi; Sangiovanni-Vincentelli, Alberto L.; Seshia, Sanjit A.; Hespanha, João P.; Tabuada, Paulo; *SMT-Based Observer Design for Cyber-Physical Systems under Sensor Attacks*, In 7th ACM/IEEE International Conference on Cyber-Physical Systems, ICCPS, 2016.
- Soltesz, Kristian; Mercader, Pedro; *Identification for Control of Biomedical Systems using a very Short Experiment*, In 2016 International Conference on Systems in Medicine and Biology, 2016.
- Soltesz, Kristian; van Heusden, Klaske; Hast, Martin; Ansermino, J. Mark; Dumont, Guy A.; *A Synthesis Method for Automatic Handling of Inter-patient Variability in Closed-loop Anesthesia*, In American Control Conference, 2016.
- Stenmark, Maj; Stolt, Andreas; Topp, Elin A.; Haage, Mathias; Robertsson, Anders; Nilsson, Klas; Johansson, Rolf; *The GiftWrapper: Programming a Dual-Arm Robot With Lead-through*, ICRA 2016 Workshop Human-Robot Interfaces for Enhanced Physical Interactions, May 16, 2016.
- Stolt, Andreas; Stenmark, Maj; Robertsson, Anders; Nilsson, Klas; *Robotic Gift Wrapping or a Glance at the Present State in Santa's Workshop*, In Reglermöte 2016.
- Thelander Andrén, Marcus; Cervin, Anton; *An Improved Stochastic Send-on-Delta Scheme for Event-Based State Estimation*, Poster 2016.
- Thelander Andrén, Marcus; Cervin, Anton; *Event-Based State Estimation Using an Improved Stochastic Send-on-Delta Sampling Scheme*, In Event-Based Control, Communication and Signal Processing 2016.
- Terraneo, Federico; Leva, Alberto; Seva, Silvano; Maggio, Martina; Papadopoulos, Alessandro Vittorio; *Reverse Flooding: exploiting radio interference for efficient propagation delay compensation in WSN clock synchronization*, In 36th IEEE Real-Time Systems Symposium (RTSS), 2016.
- Troeng, Olof; Olofsson, Björn; Bernhardsson, Bo; Johansson, Anders J; Johansson, Rolf; *Control Problems at the European Spallation Source*, In Reglermöte 2016.
- Wahrburg, Arne; Robertsson, Anders; Matthias, Björn; Dai, Fan; Ding, Hao; *Improving contact force estimation accuracy by optimal redundancy resolution*, In 2016 IEEE/RSJ International Conference on Intelligent Robots and Systems, IROS 2016.
- Yin, Lianhao; Ingesson, Gabriel; Tunestål, Per; Johansson, Rolf; Johansson, Bengt; *An Experimental Investigation of a Multi-Cylinder Engine with Gasoline-Like Fuel towards a High Engine Efficiency*, In SAE 2016 World Congress and Exhibition, 2016.

Xu, Yang; Cervin, Anton; Årzén, Karl-Erik; *Harmonic Scheduling and Control Co-Design*; In 22nd IEEE International Conference on Embedded and Real-Time Computing Systems and Applications, RTCSA 2016.

PHD THESES

Ghazaei, Mahdi; *On Trajectory Generation for Robots*; PhD Thesis Department of Automatic Control, Lund University, Sweden, November 2016.

Johnsson, Ola; *Perturbation-based Control of Industrial Fed-batch Bioprocesses*; PhD Thesis Department of Automatic Control, Lund University, Sweden, December 2015.

Magnusson, Fredrik; *Numerical and Symbolic Methods for Dynamic Optimization*; PhD Thesis Department of Automatic Control, Lund University, Sweden, October 2016.

Mannesson, Anders; *Joint Positioning and Multipath Radio Channel Estimation and Prediction*; PhD Thesis TFRT-1113, Department of Automatic Control, Lund University, Sweden, March 2016.

Stemann, Meike; *Glycemic Control and Temperature Control in Buildings*; PhD Thesis Department of Automatic Control, Lund University, Sweden, May 2016.

LICENTIATE THESES

Dellkrantz, Manfred; *Modeling and Control of Server-based Systems*; Licentiate Thesis Department of Automatic Control, Lund University, Sweden, May 2016.

Dürango, Jonas; *Control Strategies for Improving Cloud Service Robustness*; Licentiate Thesis Department of Automatic Control, Lund University, Sweden, May 2016.

Lidström, Carolina; *On Scalable H-infinity Control*; Licentiate Thesis Department of Automatic Control, Lund University, Sweden, June 2016.

TECHNICAL REPORTS

Ghazaei, Mahdi; Johansson, Rolf; *Recovery of Uniform Samples and Spectrum of Band-limited Irregularly Sampled Signals*; Technical Report Department of Automatic Control, Lund University, Sweden, June 2016.

Millnert, Victor; Eker, Johan; Bini, Enrico; *Cost minimization of network services with buffer and end-to-end deadline constraints*; Technical Report Department of Automatic Control, Lund University, Sweden, September 2016. no.

Rasmusson, Monika; Maggio, Martina (Eds.); *Activity Report 2015*; Technical Report Department of Automatic Control, Lund University, Sweden, May 2016.

Xu, Yang; Cervin, Anton; Årzén, Karl-Erik; *LQG-Based Scheduling and Control Co-Design Using Harmonic Task Periods*; Technical Report Department of Automatic Control, Lund University, Sweden, August 2016.

MASTER'S THESES

Åberg Marcus; *Optimisation-friendly modelling of thermodynamic properties of media*; Master's Thesis 0280-5316, TFRT-6011, Department of Automatic Control, Lund University, Sweden, August 2016.

Bergström, David; Göransson, Robert; *Model- and Hardware-in-the-Loop Testing in a Model-Based Design Workflow*; Master's Thesis TFRT-5999, Department of Automatic Control, Lund University, Sweden, February 2016.

Bordonaba Mateos, Nicolás; *On cascading failure models and robustness metrics in power networks*; Master's Thesis ISRN LUTFD2/TFRT--5997--SE, Department of Automatic Control, Lund University, Sweden, January 2016.

- Brand, Sebastian; Nilsson, Niklas; *Calibration of robot kinematics using a double ball-bar with embedded sensing*; Master's Thesis TFRT-6017, Department of Automatic Control, Lund University, Sweden, January 2016.
- Carstaedt, Kirsten; *Distributed Model Predictive Control for Building Temperature Control*; Master's Thesis TFRT-5998, Department of Automatic Control, Lund University, Sweden, February 2016.
- Chans, Santiago Antonio Castro; *Control and properties of processes with recycle dynamics*; Master's Thesis TFRT-6007, Department of Automatic Control, Lund University, Sweden, June 2016.
- Collin, Sandra; *Kinematic Robot Calibration Using a Double Ball-Bar*; Master's Thesis TFRT-6000, Department of Automatic Control, Lund University, Sweden, March 2016.
- Delic, Maid; *Automated Curtailment of Wind Turbines during Critical Transmission Periods*; Master's Thesis TFRT-6004, Department of Automatic Control, Lund University, Sweden, April 2016.
- Ekstedt, Edward; *Modeling and Simulation of the Cooling System in Heavy Duty Trucks*; Master's Thesis TFRT-6021, Department of Automatic Control, Lund University, Sweden, October 2016.
- Entell, Rebecka; *Embedded Recording — Tiny, low-power audio solutions for wireless systems*; Master's Thesis TFRT-6024, Department of Automatic Control, Lund University, Sweden, January 2016.
- Erwall, Charlie; Mårtensson, Oscar; *Model-based design of industrial automation solutions using FMI*; Master's Thesis TFRT-6016, Department of Automatic Control, Lund University, Sweden, October 2016.
- Fällman, Måns; *Model-Based Conductivity Control of Fluid Composition*; Master's Thesis TFRT-5992, Department of Automatic Control, Lund University, Sweden, June 2016.
- Flodin, Oscar; *Method to measure the quality of a neuron model compared to recorded data*; Master's Thesis 0280-5316, TFRT-6005, Department of Automatic Control, Lund University, Sweden, July 2016.
- Gunnarsson, Sara; *Evaluation of FMI-based workflow for simulation and testing of industrial automation applications*; Master's Thesis TFRT-6002, Department of Automatic Control, Lund University, Sweden, February 2016.
- Hedström, Staffan; *Impulse response analysis of neuromodulation for the treatment of motor symptoms in Parkinson's disease*; Master's Thesis TFRT-5993, Department of Automatic Control, Lund University, Sweden, June 2016.
- Henriks, Gustav; *Study of early termination of MPC Algorithms*; Master's Thesis TFRT-6023, Department of Automatic Control, Lund University, Sweden, December 2016.
- Heyden, Martin; *Classification of EEG data using machine learning techniques*; Master's Thesis TFRT-6019, Department of Automatic Control, Lund University, Sweden, November 2016.
- Israelsson, Alexander; Nilsson, Daniel; *Modelling and Control of a Water-Cooled Duct and Cooling System*; Master's Thesis TFRT-6015, Department of Automatic Control, Lund University, Sweden, August 2016.
- Johansson, Viktor; *Fingerprint Sensor Testing Using Force Feedback Control*; Master's Thesis TFRT-6014, Department of Automatic Control, Lund University, Sweden, August 2016.
- Kapusta, Michael; Lindstrom, Nicklas; *Access Control With High Security Credentials*; Master's Thesis TFRT-6003, Department of Automatic Control, Lund University, Sweden, February 2016.
- Léonard, Thomas; *Automatic Landing without GPS*; Master's Thesis 0280-5316, TFRT-6006, Department of Automatic Control, Lund University, Sweden, August 2016.
- Lovric, Dalibor; Olsson, Christian; *Virtual Controllers*; Master's Thesis TFRT-6022, Department of Automatic Control, Lund University, Sweden, November 2016.
- Lucke, Matthieu; *KPIs for Asset Management: A Pump Case Study*; Master's Thesis TFRT-6001, Department of Automatic Control, Lund University, Sweden, February 2016.

- Malmros, Markus; Eriksson, Amanda; *Artificial Intelligence and Terrain Handling of a Hexapod Robot*; Master's Thesis TFRT-6010, Department of Automatic Control, Lund University, Sweden, September 2016.
- Mejvik, Jacob; *Cloud Robotics for 5G*; Master's Thesis TFRT-6020, Department of Automatic Control, Lund University, Sweden, October 2016.
- Nilsson, Mikael; *Dynamic Calibration of Pressure Sensors*; Master's Thesis TFRT-6008, Department of Automatic Control, Lund University, Sweden, September 2016.
- Paulsson, Erik; Åsman, Linnéa; *Vehicle Mass and Road Grade Estimation using Recursive Least Squares*; Master's Thesis 0280-5316, TFRT-6009, Department of Automatic Control, Lund University, Sweden, June 2016.
- Stanic, Martin; *Stabilization of a thermal camera at sea*; Master's Thesis 0280-5316, TFRT-6013, Department of Automatic Control, Lund University, Sweden, August 2016.

SEMINARS AT THE DEPARTMENT

January

- 13 Master's Thesis Presentation. *On cascading failures and robustness metrics in power networks*; Nicolas Bordonaba Mateos.
- 15 Defence Of Doctoral Dissertation. *Perturbation-based control of industrial fed-batch bioprocesses*; Ola Johnsson.
- 26 Master's Thesis Presentation. *Key Performance Indicators for asset management using operational data: A case study on pumps for the Oil & Gas and Chemical industries*; Matthieu Lucke.

February

- 22 Master's Thesis Presentation. *Model-based control for modern dialysis*, Måns Fällman.
- 22 Master's Thesis Presentation. *Model-in-Loop and Hardware-in-Loop Testing in a Model-Based Design Workflow*; David Bergström and Robert Göransson.
- 24 Master's Thesis Presentation. *Access Control With High Security Credentials*; Michael Kapusta and Nicklas Lindstrom.

March

- 17 *Rate of Prefix-free Codes in LQG Control Systems*; Dr. Takashi Tanaka, KTH

May

- 2 Defence Of Doctoral Dissertation. *Joint Positioning and Multipath Radio Channel Estimation and Prediction*; Anders Mannesson.
- 4 Defence Of Doctoral Dissertation. *Methods and Tools for Co-Simulation of Dynamic Systems with the Functional Mock-up Interface*; Christian Andersson, Department of Numerical Analysis and LCCC.
- 12 *Crowd-Sourcing in Estimation and Control of Large-Scale Systems*; Dr. Farhad Farokhi, University of Melbourne, Australia.
- 13 *Speed Graph Method: Psuedo Time Optimal Navigation Among Obstacles*; Elon Rimon, Technion, Israel.

- 20 Licentiate seminar. *Modeling and Control of Server-based Systems*; Manfred Dellkrantz.
- 30 Master's Thesis Presentation. *Towards closed-loop neuromodulation for the treatment of motor symptoms in Parkinson's disease*; Staffan Hedström.
- 31 Master's Thesis Presentation. *UAV Landing Without GPS*; Thomas Léonard.
- 31 Master's Thesis Presentation. *Control and properties of processes with recycle dynamics*; Santiago Castro Chans.

June

- 2 Master's Thesis Presentation. *Vehicle Mass and Road Grade Estimation using Recursive Least Squares*; Erik Paulsson and Linnea Åsman.
- 13 Master's Thesis Presentation. *Method to measure the quality of a neuron model compared to recorded data*; Oscar Flodin.
- 13 Master's Thesis Presentation. *Evaluation of Calibration Method for Redundant Dual Arm Industrial Robots Using Internal Sensors*; Gustaf Bergström and Björn Green.
- 13 *Joint Decision Making and Motion Control for Road Vehicles*; Karl Berntorp.
- 14 Master's Thesis Presentation. *Dynamic calibration of pressure sensors*; Mikael Nilsson.
- 14 Licentiate seminar. *Control Strategies for Improving Cloud Service Robustness*; Jonas Dürango.
- 14 Master's Thesis Presentation. *Artificial Intelligence and Terrain Handling of a Hexapod Robot*; Amanda Eriksson and Markus Malmros.
- 14 Master's Thesis Presentation. *Stabilisering av IR-kamera i sökljus på fartyg*; Martin Stanic.
- 14 Master's Thesis Presentation. *Fingerprint sensor testing using force feedback control*; Viktor Johansson.
- 14 Master's Thesis Presentation. *Konfigurering av inbyggda sensorer och modeller för förbättrad elasto-kinematisk kalibrering av industriella robotar*; Sebastian Brand and Niklas Nilsson.
- 15 *A structural approach to dynamical networks*; Giulia Giordano, Lund University.
- 16 Licentiate seminar. *On Scalable H-infinity Control*; Carolina Lidström.
- 17 Defence Of Doctoral Dissertation. *Glycemic Control and Temperature Control in Buildings*; Meike Rönn.
- 20 Master's Thesis Presentation. *Optimization-friendly modelling of thermodynamic properties of media*; Marcus Åberg.
- 28 *Control in a World where Computation is Cheap and Communication is Expensive*; Leonid Mirkin.

August

- 15 Master's Thesis Presentation. *Modelling and Control of a Water-Cooled Duct*; Alexander Israelsson and Daniel Nilsson.
- 16 Master's Thesis Presentation. *Model-Based Design of industrial automation solutions using FMI*; Charlie Erwall and Oscar Mårtensson.
- 24 *Controlling Congestion on Complex Networks*; Rui Carvalho, Durham University.
- 29 Master's Thesis Presentation. *Study of early termination of MPC Algorithms*; Gustav Henriks.

September

- 7 *Industrie 4.0 – vad kan Sverige lära?*; Professor Detlef Zühlke, TU Kaiserslautern, German Research Center for Artificial Intelligence.
- 8 *Lagrangian relaxation for system identification*; Jack Umenberger, University of Sydney.
- 21 Master's Thesis Presentation. *Construction of the Berkeley Innovation Index: A Higher-Order Item Response Theory Model Approach*; Alexander Fred Ojala and Johan Eng Larsson.

October

- 3 *Process Manufacturing and the "Digital Age"; or "Embracing 'The Digital Age' Since 1951";* Don Clark, VP, Global Application Consulting & Schneider Fellow.
- 4 Master's Thesis Presentation. *Visual-based Docking of a Mobile Robot with four Omni-directional Wheels;* Farid Alijani.
- 7 Master's Thesis Presentation. *Modeling and Simulation of the Cooling System in Heavy Duty Trucks;* Edward Ekstedt.
- 7 Master's Thesis Presentation. *Classification of EEG data using machine learning techniques;* Martin Heyden.
- 7 Master's Thesis Presentation. *Cloud Robotics for 5G;* Jacob Mejvik.
- 17 *Theory and Tools for a Biomolecular Cybernetics;* Mustafa Khammash, ETH Zurich.
- 19 *Fault diagnosis in Linear Parametrically Varying systems;* Balázs Adam Kulcsár, Chalmers.
- 24 *Projected-Spectrahedral-Cone-Invariant (PSCI) Realizations of Nonnegative Impulse Responses;* Li Qiu, Hong Kong University of Science and Technology.
- 24 *Emulating Batteries with Flexible Energy Demand;* Daria Madjidian, MIT.
- 26 Master's Thesis Presentation. *Virtual Controllers;* Christian Olsson and Dalibor Lovric.

November

- 18 Defence Of Doctoral Dissertation; *Numerical and Symbolic Methods for Dynamic Optimization;* Fredrik Magnusson.
- 18 *Multi-echelon Control, Scheduling, and Design;* John Hedengren, Brigham Young University.
- 28 *Agricultural control systems;* Pontus Nordfeldt, Väderstad AB.

December

- 06 Master's Thesis Presentation; *Embedded Recording: Tiny, low power audio solutions for wireless systems;* Rebecka Erntell.
- 21 Defence Of Doctoral Dissertation; *On Trajectory Generation for Robots;* M. Mahdi Ghazaei Ardakani.

LECTURES BY STAFF OUTSIDE THE DEPARTMENT**Åström, Karl Johan**

Event Based Control; ERC Workshop Biological control across scales, Cambridge, June 27, 2016.
Control Design for a MEMS Accelerometer with Tunneling Sensing; Workshop on Control, Optimization and Networks, Cambridge, September 20, 2016.
Travels in Process Reality; LCCC Process Control Workshop, Lund, September 28, 2016.

Bernhardsson, Bo / Troeng, Olof

LLRF at the European Spallation Source; Maschine Strahlkontrollen group at Deutsches Elektronen-Synchrotron (DESY), Germany, July 12, 2016.

Cervin, Anton

LQG-optimal PI and PID control as benchmarks for event-based control; 2nd International Conference on Event-Based Control, Communication, and Signal Processing, Krakow, Poland. June 15, 2016.

TrueTime: Simulation of Networked and Embedded Control Systems; 1st Tutorial on Tools for Real-Time Systems, Vienna, Austria, April 11, 2016. Invited lecture.

Como, Giacomo

Resilient control of dynamical flow networks; Institut Henry Poincaré, (Paris, France), February 29, 2016.

Convexity and Robustness of Dynamic Network Traffic Assignment for Control of Freeway Networks; 14th IFAC Symposium on Control of Transport Systems, (Istanbul, Turkey), May 19, 2016.

Influence, Polarization, and Opinion Fluctuations in Social Networks; Workshop on Dynamics and Control in Social Systems, (Las Vegas, Nevada, USA), December 11, 2016.

Semi-plenary speaker at the 22nd International Symposium on the Mathematical Theory of Networks and Systems (MTNS'16) in Minneapolis, Minnesota (July 11-15, 2016).

Dellkrantz, Manfred

Deadtime-Compensated Elasticity Control; 8th Cloud Control Workshop, Löfvånger, Sweden, June 10, 2016.

Giordano, Giulia

A structural approach to dynamical networks; Invited MAC Seminar, LAAS-CNRS, Toulouse, October 25, 2016.

Giselsson, Pontus

Invited to session *Distributed and Large-Scale Optimization*; 55th Conference on Decision and Control, Las Vegas, USA, Dec. 12–14, 2016.

Invited talk at the *Control, Optimization, and Robotics lab*; Salento University, Lecce, Italy, Sept. 28, 2016.

Invited to session *First-order methods in model predictive control*; 4th European Conference on Computational Optimization, Leuven, Belgium, Sept. 12–14, 2016.

Invited to session *Implicit splitting methods for convex optimization*; 28th European Conference on Operations Research, Poznan, Poland, July 3–6, 2016

Invited talk at the Department of Electrical Engineering, Linköping University, Linköping, Sweden, April 21, 2016.

Invited talk at the Centre for Optimization, Convex Analysis and Nonsmooth Analysis, OBC Okanagan, Kelowna, Canada, Feb. 4, 2016.

Johansson, Rolf

Industrial Robots, Skills and Work-Space Sensing; Colloquium on Intelligent Robots and Systems, IROS2016 Senior Program Committee Meeting, Seoul, South Korea, 17-20 June 2016, June 17, 2016. Invited Lecture.

Industrial Robots, Skills and Work-Space Sensing; Stanford University, Artificial Intelligence Laboratory, Palo Alto, CA, June 30, 2016.

Industrial Robots, Skills and Work-Space Sensing; Univ. California at Berkeley, Dept Mechanical Engineering, Berkeley, CA, July 1, 2016.

Johnsson, Charlotta

Digitalisering av industrin och standardisering; presentation given at Swedish Standards Institute (SIS), Nov 29, 2016.

An international cross-disciplinary master-course on innovation and the usage of Berkeley Method of Entrepreneurship; presentation at Sten K Johnsson Centre for Entrepreneurship, Lund University, Nov 21, 2016.

Berkeley Method of Entrepreneurship; Keynote speaker at European Conference of Innovation and Entrepreneurship (ECIE2016), Jyväskylä, Finland, Sept. 15-16, 2016.

Entrepreneurial Mindset; presentation given at institute of Innovation and Entrepreneurship, University of Gothenburg, Sweden, March 3, 2016.

Entrepreneurship, Innovation and Cross-disciplinary Collaboration; presentation given at institute of Innovation and Entrepreneurship, University of Gothenburg, Sweden, March 3, 2016.

Hägglund, Tore

Control of Industrial Processes; Industrial course at Boliden - Garpenberg, May 25-26.

Rantzer, Anders

Monotone Systems; Guest lecture in PhD course at Caltech, April 26, 2016.

Scalable Control of Positive Systems; Center for Nonlinear Studies, Los Alamos National Laboratory, May 2, 2016.

On Analysis and Control of Monotone Systems; Seminar at Institute for Mathematics and Its Applications, University of Minnesota, Minneapolis, May 5, 2016.

Integral Quadratic Constraints and Monotone Systems; Tutorial lecture at the 15th annual European Control Conference, Ålborg, June 30, 2016.

Scalable Control of Positive Systems; Seminar at Chalmers, September 9, 2016.

H-infinity Control of Positive Systems; 5th International Symposium on Positive Systems (POSTA 2016), Rome, September 14, 2016.

H-infinity Optimal Control on Networks; Newton Institute Satellite Workshop, Future Directions in Network Mathematics, at the Royal Society in London, November 22, 2016.

Structure Preserving H-Infinity Optimal Control; Seminar at University of Cambridge, November 23, 2016.

On scalability in analysis and synthesis on interconnected systems; A third of a century in systems and control: a workshop dedicated to Tryphon T. Georgiou's 60th birthday, Las Vegas, December 11, 2016.

Exchange Economics as an Alternative to Distributed Optimization; 55th IEEE Conference on Decision and Control, Las Vegas, December 14, 2016.

H-infinity Optimal Control on Networks; Seminar at UC Berkeley, December 15, 2016.

Robertsson, Anders

Flexible robots and force interaction, NTNU, Trondheim, Norway, April 21, 2016.

Flexible robots and contact force interaction, DTU, Lyngby, Denmark, May 23, 2016

Using control theory to improve disaster recovery-aware backup strategy, seminar presentation at NMT-dagarna, Robotar, cyklar och andra svårstyrda saker, March 15, 2016

Seminar *Styr- och reglerteknik - vad är def?*, Vattenhallen, Lund, June 15, 2016.

POPULAR SCIENCE PRESENTATIONS

Anders Robertsson showing the RobotLab

March 2, 2016; Lärarlyft, Reglerföreläsning + Robotlabvisning,

March 7-11, 2016; Prao-elev Oskar, varav 2 dagar robotlab + 3 dagar Vattenhall

March 8, 2016; Lärarfortbildning i Vattenhallen, reglerföreläsning + Arduinoövning,

May 26, 2016; Reglerteknik+robotlabdemo, Teknikåttan,

June 1, 2016; Vattenhallen pop-vetenskapligt seminarium om Styr- och reglerteknik,

June 1, 2016; Reglerteknik+robotlabdemo (labdemo)

June 15, 2016; Styr- och Reglersystem - fortbildning hel-/halvdag, Lärarfortbildning arduino Reglerteknik

October 20, 2016; LUCAS-day, Lund, Sweden.

Nov 28 - Dec 2, 2016; EU-robotics week, the RobotLab had about 550 visitors during EURobotics week 2016.



Välkomna då Lunds universitet firar 350 år!

Universitetets 350-årsjubileum pågår 19 december 2016 – 28 januari 2018 – alltså under drygt ett år.

Jubileumsåret är en möjlighet för Lunds universitet att uppmärksamma utbildning, forskning, de senaste innovationerna och samarbeten som leder universitetet mot framtiden. Under 2017 blir Lunds universitet ett ännu öppnare universitet än vanligt, helt enkelt.

Jubileet vänder sig till alla intresserade, från framtida och nuvarande studenter, alumner, samarbetspartners och Lundabor till forskningsintresserade och många fler. Även deltagare som kommer långväga ifrån välkomnas då vi har flera veckolånga programaktiviteter som gör resan hit väl värd.



LUND
UNIVERSITY



Department of Automatic Control
P O Box 118, 221 00 Lund, Sweden
www.control.lth.se

Annual Report TFRT--4044
ISSN 0280-5316