



LUND UNIVERSITY

Activity Report: Automatic Control 2009

Westin, Eva; Johansson, Rolf

2010

Document Version:

Publisher's PDF, also known as Version of record

[Link to publication](#)

Citation for published version (APA):

Westin, E., & Johansson, R. (Eds.) (2010). *Activity Report: Automatic Control 2009*. (Annual Reports TFRT-4037). Department of Automatic Control, Lund Institute of Technology, Lund University.

Total number of authors:

2

General rights

Unless other specific re-use rights are stated the following general rights apply:

Copyright and moral rights for the publications made accessible in the public portal are retained by the authors and/or other copyright owners and it is a condition of accessing publications that users recognise and abide by the legal requirements associated with these rights.

- Users may download and print one copy of any publication from the public portal for the purpose of private study or research.
- You may not further distribute the material or use it for any profit-making activity or commercial gain
- You may freely distribute the URL identifying the publication in the public portal

Read more about Creative commons licenses: <https://creativecommons.org/licenses/>

Take down policy

If you believe that this document breaches copyright please contact us providing details, and we will remove access to the work immediately and investigate your claim.

LUND UNIVERSITY

PO Box 117
221 00 Lund
+46 46-222 00 00

Automatic Control 2009

Activity Report

Automatic Control 2009

Department of Automatic Control
Lund University
Sweden

Mailing address

Department of Automatic Control
Lund University
Box 118
SE-221 00 LUND, SWEDEN

Visiting address

Institutionen för Reglerteknik
Lunds universitet
Ole Römers väg 1. LUND

Telephone

Nat 046 - 222 87 80
Int +46 46 222 87 80

Fax

Nat 046 - 13 81 18
Int +46 46 13 81 18

Generic e-mail address

control@control.lth.se

WWW and Anonymous FTP

www.control.lth.se
<ftp://ftp.control.lth.se/pub>

This report was edited by Eva Westin and Rolf Johansson.

Printed in Sweden
Mediatryck, Lund, April 2010

ISSN 0280-5316
ISBN LUTFD2/TFR--4036--SE

Contents

1. Introduction 6
2. Internet Services 8
3. Economy and Facilities 9
4. Education 12
5. Research 15
6. External Contacts 61
7. Looking Back on Computers 65
8. Dissertations 90
9. Honors and Awards 96
10. Personnel and Visitors 97
11. Staff Activities 101
12. Publications and Conference Contributions 118
13. Reports 125
14. Lectures by the Staff Outside the Department 131
15. Seminars at the Department 137

1. Introduction

This report covers the activities at the Department of Automatic Control at Lund University from January 1 to December 31, 2009—a year with several good news and interesting events. The Linnaeus Center LCCC granted in 2008 from the Swedish Research Council increased our research budget with about 40%. The LCCC has resulted in an increasing number of employees, a number that previously has been fairly constant for many years. Currently, we are now around 50 people working at the department. The number of visitors, both long term and short term, is also increasing, mainly financed by the Linnaeus grant.

We teach undergraduate courses in almost all engineering programs at the university. This year we gave 12 courses to 692 students, and 20 students presented their master's thesis at our department. The total teaching effort corresponds to 89 full-year equivalents. More details about the education at the department are given in Chapter 4. Two PhD theses were defended this year by Oskar Nilsson and Martin Ansbjerg Kjaer. Three licentiate theses were presented by Olof Garpinger, Anders Widd and Aivar Sootla. During 2009, Karl Berntorp, Anna Lindholm, Alina Rubanova and Meike Stemmann were admitted to graduate study. Ahmed El-Shaer and Vladimeros Vladimerou were admitted as post-doctoral researchers. In March, Ingrid Nilsson joined the staff as an administrator and, from October, Anders Nilsson as a research engineer.

Three scientists with doctorates or a licentiate left the department: Olof Garpinger, Martin Ansbjerg Kjaer and Oskar Nilsson.

During 2009 the department hosted two international meetings: On May 28-29, 2009, the Lund Center for Control of Complex Engineering Systems (LCCC) had its first workshop. The first day presented application areas involving opportunities and challenges for control of complex systems. The second day was more theory-oriented, with focus on distributed decision-making and control. On June 8-9, 2009, the Korea-Sweden Robotics Symposium was held.

The main part of this report consists of a description of current research at the department. Chapter 5 describes most of the research pro-

jects under the following headlines: Modeling and Control of Complex Systems, Control and Real-Time Computing, Process Control, Robotics, Automotive Systems, and Biomedical Projects. The following chapters give more details about staff activities and publications. A summary of the publications from the department is given by the following table:

	05	06	07	08	09	Sum
Books	1	1	1	3	1	7
Articles	21	19	19	21	16	96
Conference papers	33	53	32	33	41	192
PhD theses	2	3	5	3	2	15
Licentiate theses	3	3	0	2	3	11
Master's theses	27	20	24	24	16	111
Internal reports	2	4	5	3	2	16

To give a perspective, the table shows the publications from the last five years. It shows that the publication rate has been fairly constant during the years. However, mainly because of the Linnaeus grant we expect an increase in publications in the years to come.

In honor of Per Hagander on the occasion of his retirement, the Hagander Seminar with about 95 participants was held on December 10 with contributions from previous colleagues and students. The Hagander Seminar ended with a dinner at Grand Hotel.



Acknowledgements

We want to thank our main sponsors:

VINNOVA (The Swedish Agency for Innovation Systems), VR (The Swedish Research Council), The European Commission, SSF (Swedish Foundation for Strategic Research), ABB Robotics, ABB Corporate Research Sweden/Germany, Gudel AG Switzerland, Novo Nordisk AS, KCFP (Competence Center Combustion Processes), Castings Technology International and STINT.

2. Internet Services

World Wide Web

Visit our homepage at this address:

www.control.lth.se

Our website contains information about personnel, research, publications, seminars, education etc. It also contains fairly complete lecture notes for many courses, and in some cases software tools such as Matlab tool-boxes developed at the department. Our home-page first appeared on the World Wide Web (WWW) in April 1994.

Electronic Mail

All personnel can be contacted by electronic mail. A personal email address consists of the full name and the department address in the following form:

`firstname.lastname@control.lth.se`

Double names are separated by underline, hyphens are treated as ordinary characters and accents are ignored. Examples:

`anders.rantzer@control.lth.se`

`karl-erik.arzen@control.lth.se`

Our web page

www.control.lth.se/people/telemail.html

contains a complete list of email addresses and phone numbers. The department also has a generic email address:

`control@control.lth.se`

Emails to this address are continuously read by the postmaster and forwarded to the appropriate receiver.

3. Economy and Facilities

The turnover for 2009 was 38,1 MSEK. The income comes from Lund University (50%) and from external grants (50%). The distribution is shown below.

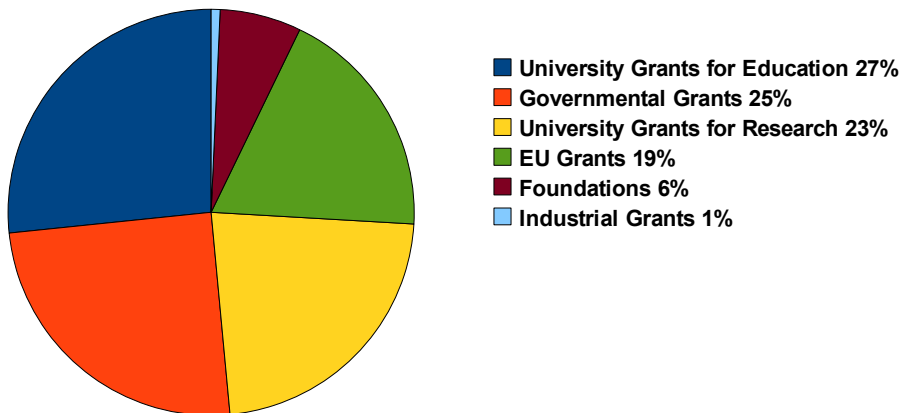

Funding

Lund University provides most of the support for graduate students. Our research is externally funded from governmental agencies and industry. During 2009 we had the following contracts:

- VR – Control with decentralized information
- VR – Active Control of Compressor Systems Based on New Methods of Nonlinear Dynamic Feedback Stabilization
- VR – Modelling and Control of Server Systems
- VR – Decentralized Structures for Industrial Control II

Chapter 3. Economy and Facilities

- VR – Periodic and Event-Based Control over Networks
- VR – Linnaeus grant Lund Center for Control of Complex Engineering Systems LCCC
- VINNOVA-Ericsson – Feedback Based Resource Management and Code Generation for Soft Real-Time Systems
- VINNOVA – 2006-03689 ITEA – European Leadership in System Modeling and Simulation through advanced Modelica Libraries
- SSF – ENabling GROwing Software Systems ENGROSS
- SSF – Center for Chemical Process Design and Control CPDC
- EU – FP7 ICT-230902 Robot control for Skilled ExecUTion of Tasks in natural interaction with humans; based on Autonomy, cumulative knowledge and learning ROSETTA
- EU – NMP2-CT-2005-011838 The European Robot Initiative for Strengthening the Competitiveness of SMEs in Manufacturing (SMErobot)
- EU – ICT-216586 Adaptivity and Control of Resources in Embedded Systems ACTORS
- EU – ICT-216592 Personal Health Systems for Monitoring and Point-of-Care Diagnostics DIAdvisor
- EU – ICT-97518 ArtistDesign – Design for Embedded Systems ARTIST-DESIGN
- EU ICT-224428 Control of Heterogeneous Automation Systems: Technologies for Scalability, Reconfigurability and Security CHAT
- EU – ICT-224548 Distributed Control of Large-Scale Offshore Wind Farms project proposal AEOLUS
- Toyota Motor Corporation – Project on Nonlinear Model Reduction
- Swedish Energy Agency (STEM) – Competence Center Combustion Processes, KCFP, Ref. 22485
- SKB – (Assistera industridoktorand med att) Trimma och verifiera den framtagna regulatorstrukturen (Control of Stirwelding Process for Sealing)
- Vägverket – Estimering av vägfriktion (Estimation of Road Friction)
- STINT – Institutional grant for cooperation with Hanyang, Korea
- Royal Physiographic Society – Scholarship + Symposium

The block grant from VR and some of the VINNOVA projects are long range. Several projects do, however, have a duration of only two years. To match these with the length of a PhD position, which is much longer, we have an internal research planning that is much more long range and we are careful to bid on projects that fit our long range research plan. This has proven an efficient way to match short-term funding to long term planning.

Teaching Laboratory

The teaching laboratories are based on desktop processes and personal computers. These laboratories are used in all our courses. The introductory courses give a heavy load on the teaching laboratories because of the large number of students. There are about 800 students per year in total in all our courses and on the average they spend about 15 hours each in the laboratories.

Since the introduction of the “Tickless Kernel feature” in Linux 2.6.17, we now run all the laboratories with a standard Linux kernel, since this is now capable of running control tasks in sub-millisecond range. The limiting factor is still the determinism of Simulink and Java respectively.

The water tank process used in several undergraduate courses has been redesigned by Rolf Braun during the summer. Twelve new units, with four tanks each, have been built to replace the existing stock. Software and lab manuals for the new process have been written by Olof Garpinger and Kristian Soltesz.

Some of the lab processes have been moved to Zhejiang University in Hangzhou, China, in order to be used in teaching the Basic Course in Automatic Control.

A water tank set-up is also on public display for experiments at the LTH Science Center *Vattenhallen*.

4. Education

Engineering Program

The engineering education follows the central European systems with a five year program leading up to the degree “civilingenjör” (civ.ing.), which corresponds to an MSc in the US and British systems.

Automatic control courses are taught as part of the engineering curricula in Engineering Physics (F), Electrical Engineering (E), Computer Engineering (D), Mechanical Engineering (M), Information and Communication Engineering (C), Environmental Engineering (W), Engineering Mathematics (Pi), Industrial Management and Engineering (I), Biotechnology (B), Engineering Nanoscience (N) and Chemical Engineering (K).

During 2009 the department has been involved in courses given together with Lund University School of Economics and Management. Within this interdisciplinary cooperation called Technology Management, 20 future engineers have completed a master's thesis in pair with a future economist. These students have also completed different courses on the subject.

During 2009, 829 students passed our courses and 40 students completed their master's thesis projects. A list of the master's theses is given in Chapter 12. The number of registered students correspond to 118 full-year equivalents during the year. The numbers for 2008 were 756, 30 and 108 respectively.

In Table 4.1 below, our courses are listed along with the number of students who passed each course.

Table 4.1 Courses and the number of students who passed.

Reglerteknik AK FRT010 (Automatic Control, Basic Course)	385
Realtidssystem FRTN01 (Real-Time Systems)	19
Prediktiv reglering FRTN15 (Predictive Control)	25
Internationell projektkurs i reglerteknik FRT100 (International Project Course in Automatic Control)	8
Processreglering FRT081 (Process Control)	10
Reglerteori FRT130 (Control Theory)	23
Flervariabel reglering FRTN10 (Multivariable Control)	32
Systemidentifiering FRT041 (System Identification)	19
Systemteknik FRT110 (Systems Engineering)	43
Olinjär reglering och servosystem FRTN05 (Nonlinear Control and Servo Systems)	30
Projekt i reglerteknik FRT090 (Projects in Automatic Control)	25
Matematisk modellering FK FRT095 (Mathematical Modelling, Advanced Course)	53
Examensarbete FRT820 (Master's Thesis Project)	20
Examensarbete TMA820 (Master's Thesis Project within Technology Management)	20
TMA-kurser (Technology Management Courses) TMA035, TMA037, TMA010	40

Information on WWW

Most students have access to Internet via Lund University. Therefore we have made a great effort to present the education on web pages. Each course in the engineering program has its own homepage, documentation, manuals, old exams etc. We also have information sheets about the engineering courses, the master's theses and the doctorate program. You'll find the links at www.control.lth.se/education/.

Doctorate Program

Two PhD theses were defended this year by Oskar Nilsson and Martin Ansbjerg Kjaer. This brings the total number of PhDs graduating from our department to 86. Three licentiate theses were also presented during 2009. Abstracts of both PhD and licentiate theses are given in Chapter 7.

We have admitted Karl Berntorp, Anna Lindholm, Alina Rubanova and Meike Stemmann as PhD students during the year.

The following PhD Courses were given in 2009:

- Numerical Methods for Dynamic Optimization (Johan Åkesson, Alexandra Grancharova), 7,5 hp
- Introduction to Hybrid Systems and Verification (Vladimeros Vladimerou), 7,5 hp
- Introduction to Modelica (Johan Åkesson), 5 alt. 7,5 hp
- Linear Systems (Bo Bernhardsson), 9 hp
- Reading Assignment in Information Theory (Bo Bernhardsson), 6 hp
- Embedded Systems (Anders Rantzer), 7,5 hp
- Convex Optimization with Applications (Anders Rantzer), 7,5 hp

5. Research

The goal of the department is to provide students with a solid theoretical foundation combined with a good engineering ability. This is reflected in the research program which covers both theory and applications. The major research areas are:

- Modeling and Control of Complex Systems
- Control and Real-Time Computing
- Process Control
- Robotics
- Automotive Systems
- Biomedical Projects

In July 2008, the department became host for a Linnaeus grant from the Swedish Research Council worth 75 MSEK over 10 years. The grant is used to fund a new center called LCCC – Lund Center for Control of Complex Engineering Systems. The main research areas of LCCC are illustrated in the picture below:

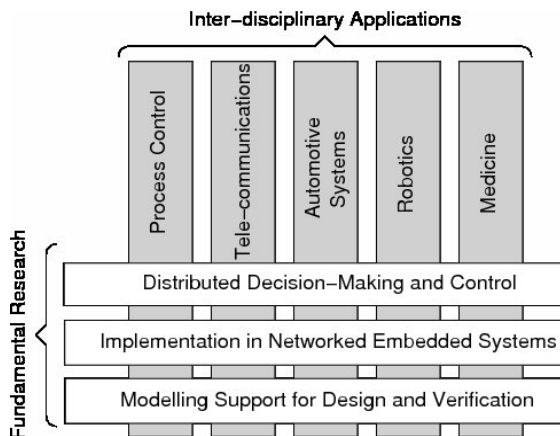

Chapter 5. Research

In the following presentation the research at Automatic Control LTH is in most cases broken down to the granularity of a PhD thesis. There are of course strong relations between the different projects.

Modeling and Control of Complex Systems

Theory and computer tools are developed to deal with fundamental complexity issues appearing in for example vehicles, power systems and communications.

Distributed Control of Complex Systems

Researchers: Pontus Giselsson, Karl Mårtensson, Daria Madjidian, Erik Johannesson and Anders Rantzer

Funding: SSF-Senior Individual Grant, Swedish Research Council

How should control equipment distributed across the power grid in southern Scandinavia cooperate to quickly find new transmission routes when a power line is broken? How should the electronic stabilization programme (ESP) of a car gather measurements from wheels and suspensions and decide how to use available brakes and engine power to recover from a dangerous situation? How can a large number of sensors and actuators be coordinated to control the dynamics of a flexible mechanical structure?

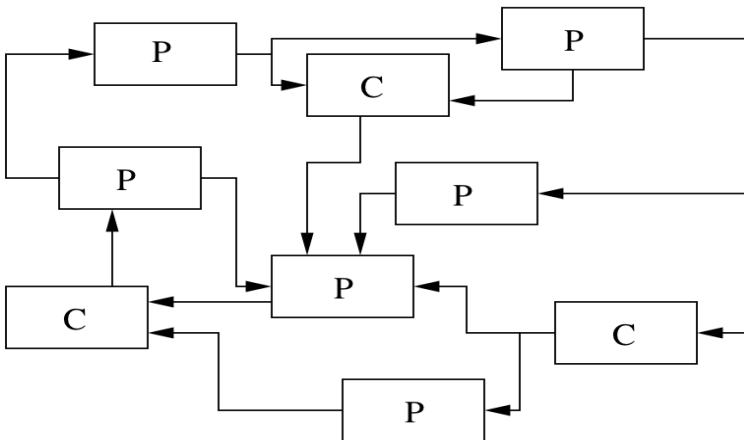

All these questions are examples of distributed control problems, where several controllers need to cooperate with access to different information and with bounds on the communication between them. Most of traditional control theory was developed with a centralized viewpoint. However, recently important steps were taken in the new direction of distributed control theory, building on a historical development dating back to economic game theory and statistical decision theory from the 1960s.

We are currently addressing these problems from a general system theoretic viewpoint, but with particular attention to the following three applications:

- Control of power networks
- Dynamic positioning of laboratory vehicles using sensor networks
- Control of buffer sizes in manufacturing systems

AEOLUS - Distributed Control of Large-Scale Offshore Wind Farms

Researchers: Daria Madjidian, Ahmed H. El-Shaer, Kin Cheong Sou, Anders Rantzer in collaboration with project partners from Aalborg University, Industrial Systems and Control Ltd in Glasgow, University of Zagreb, Energy Research Centre of the Netherlands and Vestas Wind Systems A/S. . Duration: May 2008 – April 2011

Funding: EU/IST/FP7

Aeolus is an European research project funded by the European Commission under the IST framework program 7 for Information and Communication Technology, ICT.

The main goal of Aeolus is to research and develop models that allow real-time predictions of flows and incorporate measurements from a set of spatially distributed sensor devices. In Aeolus we will use the flow information as a basis for new control paradigms that acknowledge the uncertainty in the modeling and dynamically manage the flow resource in order to optimize specific control objectives.

CHAT - Control of Heterogeneous Automation Systems

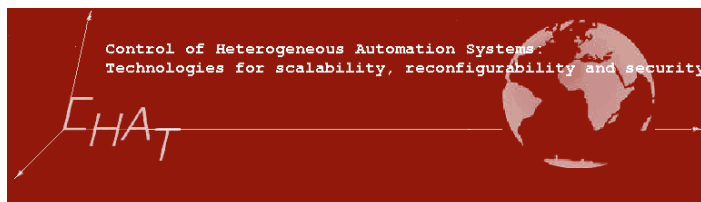

Researchers: Pontus Giselsson, José Maestre, Karl Mårtensson, Anders Rantzer, Vladimeros Vladimerou, in collaboration with project partners from University of Pisa, Siemens AG, University of Trento, University College London, Eltag Datamat, Sofidel and University of Salento .

Duration: September 2008 – August 2011

Funding: EU/IST/FP7

Scalability, reconfigurability, and security are three aspects of paramount importance in developing efficient, predictable, and safe control architectures for large-scale networked industrial automation. At present, the state of control systems technology is such that the supervision and control of larger and more complex plants cannot be achieved without considerable costs in terms of hard infrastructure and software development.

CHAT is a research project exploring the research and engineering challenges inherent in the development of algorithms, protocols and procedures for next generation distributed control systems, in order to drastically reducing infrastructure, maintenance and reconfiguration costs.

The Department of Automatic Control is involved in developing price mechanisms for distributed control as well as consensus and distributed estimation algorithms. Currently the focus is on using such methods for mobile robot task allocation. We have also provided simulation environments, extended to incorporate industrial network standards to our partners (FlexRay and PROFINET in Truetime).

Control with Communication Constraints

Researchers: Erik Johannesson, Anders Rantzer, Bo Bernhardsson, Andrey Ghulchak

Funding: Swedish Research Council

Classical control theory assumes perfect communication, without limitations, between different parts of the control system and the process. In recent years there has been a lot of interest in the control community regarding the interplay between communication and control. This interest has resulted in some results, mainly concerning fundamental limitations of control performance that arise from communication limitations.

In this project we study control systems where communication is taking place over channels, modeled as additive Gaussian noise channels. These channels give an incentive to perform coding and decoding of the transmitted signal, in addition to filtering and computation of control signals. The problem of designing the controller, coder and decoder simultaneously is a distributed control problem, which we aspire to solve using tools from convex optimization. Currently, we are focusing on the problem structure illustrated by this block diagram:

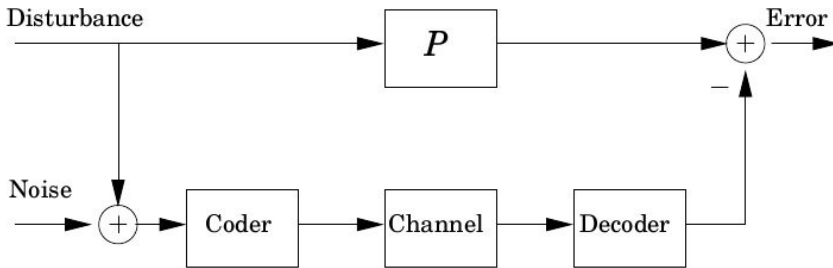

The objective is to design the coder and the decoder so that the error is minimized. This can be interpreted as the design of a disturbance feed-forward compensator, where the sensor and the actuator are geographically separated and have to encode their communication.

In essence, this project is of a theoretical and fundamental nature. However, the results may be relevant for design of networked control systems and certain applications such as power control in cell phones.

Modeling and Validation of Complex Systems

Researchers: Oskar Nilsson, Aivar Sootla, Kin Cheong Sou, Anders Rantzer

Funding: Swedish Research Council, Toyota Motor Corporation

Large complex mathematical models are regularly used for simulation and prediction. However, in control design it is a common practice to work with as simple process models as possible. This makes it easier to analyze and evaluate the model, or to use it as a component for efficient system-wise evaluation. On the other hand, models are typically dependent on some adjustable parameters, which allow system design. Therefore, the capability of simplifying parameter dependent models is important from an efficient design point of view. One objective of this project is to develop methods for parameterized model reduction, where a single parameter dependent reduced model is an accurate simplification of the original complex model for all the parameter values of interest. In this project, a semidefinite programming based parameterized model reduction method is being developed.

Another aspect of this project is to develop model reduction tools that take into account the properties and restrictions of large scale distributed networked systems. Model reduction schemes guaranteeing overall system stability are being developed. In addition, structure preserving model reduction and network topology simplification methods are also being investigated.

Previous research outcome of this project includes balanced truncation and its extension to nonlinear and hybrid systems and average Gramian nonlinear model reduction approaches based on linearization around simulated trajectories. Engine models from Toyota Motor Corporation are used as test cases.

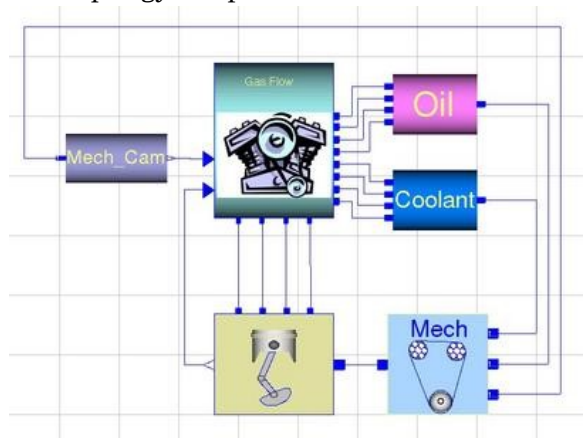

Schematic picture of an engine model.

Relaxed Dynamic Programming

Researchers: *Andreas Wernrud and Anders Rantzer*

A new approach to synthesis of nonlinear and hybrid observers and controllers is currently developed by extending the classical idea of dynamic programming. This method was introduced by Bellman in the 1950s and has found many important applications since then. The idea is general and very simple, but the 'curse of dimensionality' is often prohibitive and has previously restricted most applications to a discrete state space of moderate size. Our idea is to use a relaxed version of dynamic programming to find approximations of the cost function. It turns out that finding a solution which is guaranteed to be within 10% from the optimum can be much less expensive than finding one within 1%.

Our current research on this topic includes performance analysis in model-predictive control, optimal estimation using sensor switching and control synthesis for DC-DC converters.

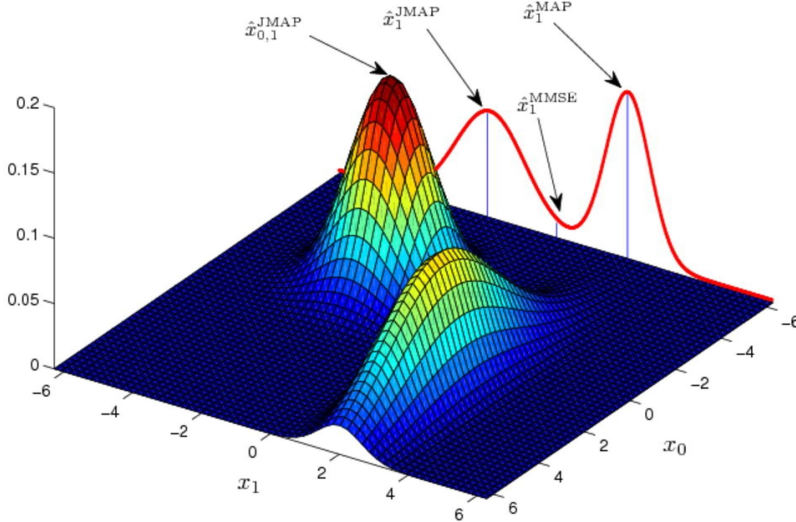

The figure above illustrates an example where the cost to go is computed backwards in time, starting at $T=200$. The three parameter values 1.01, 1.1 and 1.5 correspond to accuracies of 1%, 10% and 50% respectively.

ively. Notice that the size of the search tree first grows exponentially for time steps down to about $T=180$, then the size starts to shrink and finally stabilizes at a lower level that depends on the requested optimization accuracy.

Language Support for Dynamic Optimization

Researchers: Johan Åkesson and Karl-Erik Årzén

Overview

Efficient development and operation of control systems is essential in industry today. Optimization is increasingly used as a standard tool to improve operation, both in on-line and off-line applications. Examples are calculation of operating points, grade change trajectories and production schedules that maximize production while minimizing raw material, energy and other resources. Similar issues arise in the design of embedded control systems for e.g., the automotive, avionics, and mobile telecom areas, where efficient utilization of computing, communication, and/or battery resources is required in order to meet market demands. This can also often be formulated as optimization problems.

Due to the ever increasing complexity of plants, a model-driven approach is required. At the heart of this project is a language-based approach for developing a high-level description framework targeted at unified modeling of physical systems and associated optimization problems. This also includes development of prototype software, which transforms a high-level description into a canonical mathematical model representation. This canonical representation may then be used as a basis for code generation for the above mentioned applications. The main topic of the project is the formulation of large-scale optimization problems. Associated with this topic is also code generation for numerical solvers.

Optimica

A key issue is the definition of syntax and semantics of the Modelica extension, Optimica. Optimica provides the user with language constructs that enable formulation of a wide range of optimization problems, such as parameter estimation, optimal control and state estimation based on Modelica models.

At the core of Optimica are the basic optimization elements such as cost functions and constraints. It is also possible to specify bounds on

variables in the Modelica model as well as to mark variables and parameters as optimization quantities, i.e., to express what to optimize over. While this type of information represents a canonical optimization formulation, the user is often required to supply additional information, related to the numerical method which is used to solve the problem. In this category we have e.g., specification of transcription method, discretization of control variables and initial guesses. Optimica also enables convenient specification of these quantities.

The first version of Optimica was published in 2007. Current research focuses on extending Optimica to support specification of Model Predictive Controllers (MPC), mixed-integer programs and multistage problems.

Software Tools - the Jmodelica.org platform

One of the results of the research project is an open source project entitled JModelica.org. JModelica.org is an extensible Modelica-based open source platform for optimization, simulation and analysis of complex dynamic systems. The main objective of the project is to create an industrially viable open source platform for optimization of Modelica models, while offering a flexible platform serving as a virtual lab for algorithm development and research. As such, JModelica.org is intended to provide a platform for technology transfer where industrially relevant problems can inspire new research and where state of the art algorithms can be propagated from academia into industrial use. JModelica.org is currently managed by the Lund-based company Modelon AB and continues to evolve in close collaboration with several departments at Lund University, including Automatic Control, Mathematics and Computer Science.

JModelica.org features compilers supporting code generation of Modelica models to C, a C API for evaluating model equations and their derivatives and optimization algorithms. The compilers and the model C API has also been interfaced with Python in order to enable scripting and custom application development. In order to support formulation of dynamic optimization of Modelica models, JModelica.org supports the Optimica extension. Solution of dynamic optimization problems is supported by an implementation of a simultaneous collocation algorithm based on the NLP solver IPOPT.

Applications and Related Projects

JModelica.org, and prototypes thereof, have been used in a number of industrial size applications. These include start-up optimization of a plate reactor, lap time optimization for racing cars and optimal robot control. In a recent project, JModelica.org is used to compute optimal grade change profiles in collaboration with plastics manufacturer Borealis. For details, see the corresponding research home page. The project is also related research on parallel methods for dynamic optimization.

Inducing Stable Oscillations in Nonlinear Systems by Feedback

Researchers: Rolf Johansson and Anders Robertsson in cooperation with Prof. A. Shiriaev, Umeå University, Swedish Research Council 2006-2008, Ref. 2005-4182

The aim of this project is to develop feedback control laws for nonlinear dynamical systems represented by the classical Euler-Lagrange equations. We consider the systems with the number of actuators being less than the number of its degrees of freedom (DOF) by one. Examples of such dynamical systems are ubiquitous, for instance, a cart-pendulum system (2 DOF correspond to position of the cart and angle of the pendulum, 1 actuator produces the force applied to the cart) and a model of a ship on a plane (3 DOF; 2 actuators). The two problems, approached in the project, are: how to derive a simple and efficient algorithm of motion planning for such a under-actuated systems and how to make a pre-planned motion orbitally stable in the closed loop. It is well known that feedback control design for under-actuated systems is inherently difficult task since not every desired motion is feasible for a system with not actuated DOF. Our controller design approach is based on the idea of virtual holonomic constraint: geometrical relations imposed between generalized coordinates, which are made invariant for the closed loop system. Exploiting this idea, we have obtained series of preliminary results, in particular, on reducibility of dynamics, integrability of zero dynamics, extension of the famous Lyapunov lemma on presence of center in a nonlinear system, constructive procedure for exponential orbital stabilization of pre-planned motions, extensions to hybrid dynamical systems.

Active Control of Compressor Systems Based on New Methods of Nonlinear Dynamic Feedback Stabilization

Researchers: Rolf Johansson and Anders Robertsson in cooperation with Prof. A. Shiriaev, Umeå University, Swedish Research Council 2007-2009, Ref. 2006-5243

This project deals with a number of facts related to the output feedback stabilization of the Moore-Greitzer compressor model. We show that quadratic feedback stabilization of the surge subsystem of the three-state Moore-Greitzer compressor model, which ensures an absence of additional equilibria in the augmented with stall dynamics closed loop system, implies convergence of all solutions to the unique equilibrium at the origin. Then some steps in developing such output feedback controller for surge subsystem are discussed, and a family of controllers is presented. Based on our new theoretical results on integrability, stability, nonlinear dynamic output feedback control, we wish to pursue active control application to compressor systems and experimental verification.

Parallel Methods for Dynamic Optimization

Researchers: Philip Reuterswård, Johan Åkesson, Karl-Erik Årzen

Optimization is used extensively in many contexts in control engineering. Applications include design optimization to develop optimal processes, set-point optimization to minimize raw material and energy consumption, and on-line optimal control strategies such as Model Predictive Control (MPC). As systems are becoming increasingly complex, the need for efficient computational methods is put into focus.

The proposed research project is motivated by Moore's law, which states that the maximum number of transistors that be fit into an Integrated Circuit to a reasonable cost is doubled every other year. For decades, Moore's law has been closely related to important performance measures, for ex-

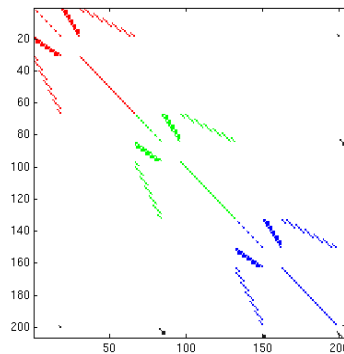

ample the computational power of processors found in desktop computers. During the last 3-4 years this situation has changed, however. While the number of transistors on an Integrated Circuit continues to increase rapidly, many software applications does not run at correspondingly higher execution speeds. The explanation is that modern processors are equipped with multiple cores. Also, the clock frequency, which directly affect execution speed, is increasing only moderately. Many applications are capable of utilizing only one core, and cannot benefit from the availability of multi-core architectures.

In order to utilize more than one core, new methods and/or application of known methods in new contexts are needed. Such methods are typically specific for different application areas. In the field of dynamic optimization, development of parallel and distributed methods is essential in order to efficiently meet the challenges outlined above. In principle, there are two different scenarios that require attention. In the first scenario, the main challenge is the complexity of the problem. In this case, decomposition and parallelization is important in order to obtain manageable subproblems to distribute amongst the available cores. In the second scenario, the complexity of the problem may be moderate, but the computation time is critical. For example, MPC falls into this category. In this case, parallel algorithms are needed in order to fully explore the computational power of multi-core architectures and thereby reduce computation times.

Control and Real-Time Computing



Adaptivity and Control of Resources in Embedded Systems (ACTORS)

Researchers: Mikael Lindberg, Anton Cervin, and Karl-Erik Årzén in collaboration with the other 6 core partners. Duration: February 2008 – January 2011

Funding: EU/IST/FP6 STREP

ACTORS is an EU/IST FP7 STREP on feedback-based resource management and data-flow modeling in embedded systems. The other partners in the project are:

- Ericsson (Coordinator) – Johan Eker
- Scuola Superiore Sant'Anna di Pisa – Giorgio Buttazzo
- TU Kaiserslautern – Gerhard Föhler
- Ecole Polytechnique Fédérale de Lausanne – Marco Mattavelli
- Evidence Srl – Paolo Gai
- AKAtch SA – Vincent Noel
- Xilinx – Jörn W. Janneck

Feedback Based Resource Management and Code Generation for Soft Real-Time Systems (FISS2)

Researchers: Mikael Lindberg, Anton Cervin, and Karl-Erik Årzén in collaboration with Ericsson. Duration: Spring 2007 - Dec 2009

Funding: VINNOVA via Ericsson

FISS2 is an VINNOVA/Ericsson project within the so called Swedish Telecom-initiative. The topic of the project is reservation and feedback resource management in mobile multimedia terminals.

Design of Embedded Systems (ArtistDesign)

Researchers: Toivo Henningsson, Mikael Lindberg, Anders Robertsson, Anton Cervin, and Karl-Erik Årzén in collaboration with the other 31 core partners of the EU IST FP7 ArtistDesign Network of Excellence. Duration: January 2008 – December 2011

Funding: EU/IST/FP7

ArtistDesign is an EU/IST FP7 network of excellence on design of embedded systems. It is a follow-up project to the FP6 NoE Artist2. The objective of ArtistDesign is to strengthen European research in Embedded Systems Design, and promote the emergence of this new multi-disciplinary area. ArtistDesign gathers together the best European teams from the composing disciplines, and will work to forge a scientific community.

Internally ARTIST2 is divided into four thematic clusters (Modeling and Validation; SW Synthesis, Code Generation and Timing Analysis; Operating Systems and Networks, and Hardware Platforms and MPSoC Design) and one transversal integration cluster. Lund is a member of the Operating Systems and Networks cluster. Karl-Erik Årzén is also the leader of the Design for Adaptivity activity within the integration cluster.

EUROSYSLIB

Researchers: Martin Hast, Anton Cervin, Johan Åkesson and Karl-Erik Årzén in collaboration with Dynasim. Duration: Summer 2007 - December 2009

Funding: ITEA2/VINNOVA

The ultimate objective of EUROSYSLIB is to make Modelica the de-facto standard language for embedded system modelling and simulation. In order to support this major product lifecycle management effort, the EUROSYSLIB consortium, composed of 20 European partners, is committed to delivering a large set of high-value, innovative modelling and simulation libraries based on the freely available Modelica object-oriented modelling language. The role of Lund University is to develop a network simulation library for Modelica with features that are similar to the network blocks in the TrueTime simulator developed at Lund University.

LUCAS Center for Applied Software Research

Researchers: Karl-Erik Årzén, Rolf Johansson, Anders Robertsson, Anton Cervin, Dan Henriksson, Karl Berntorp, Anders Blomdell, and Leif Andersson in collaboration with Department of Computer Science, Department of Communication Systems, and industry.

The Center for Applied Software Research (LUCAS) is a collaboration between the software-oriented parts of three departments at LTH:

- Computer Science
- Communication Systems, and
- Automatic Control

In total around 15 faculty members and 20 PhD students are involved in LUCAS. The focus of LUCAS is industrially-oriented and motivated software research. This includes research on software engineering, software technology, and software applications. Special focus is put on real-time systems, in particular embedded systems, networked systems, and control systems. The work is organized along three thematic areas:

- Software Engineering Environments
- Methods in Software Engineering
- Real-Time Systems Software

The first thematic area focuses on the core areas of integrated environments (tools and methods), object-oriented languages in the tradition of Simula, Beta, and Java, and embedded systems.

The research method is focused on experimental implementation and development of relevant theory. Examples of issues that are studied are configuration management, collaboration support, domain-specific languages, frameworks and patterns and Java for embedded systems. The second thematic area is focused on software development processes, methods and architectural issues for development and maintenance of complex software systems. More specifically, the research is directed towards the following key areas: software quality, verification and validation, requirements engineering, and software process architectures. The research is approached through empirical studies to understand, assess, and improve software development. The third thematic area is focused on the software aspects of real-time systems, in particular embedded system, networked systems, and control systems. Some examples of topics

within the area are real-time kernels and run-time systems for embedded systems, system architectures for real-time control systems in e.g., industrial automation and robotics, integrated approaches to control design and CPU and communication bandwidth scheduling, and verification and validation of real-time systems.

The activities within LUCAS consist of research projects in collaboration with industry, center activities, and teaching activities. The projects can span the full range of LUCAS or be focused on one of the thematic areas. The aim of the center activities is to maintain the infrastructure of LUCAS and to disseminate information among the partners. The teaching activities include both graduate-level courses and continued education courses.

Industries can join LUCAS at three levels of participation. A gold member is involved in projects over the full range of LUCAS and has a long-term strategic interest in the activities of LUCAS. Silver participants are involved in a single research project, whereas bronze members have access to the LUCAS network in terms of seminars, tutorials, courses, and workshops.

Control of Computer Server Systems

Researchers: Anders Robertsson, Martin Ansbjerg Kjær, Karl-Erik Årzén, and Björn Wittenmark, in cooperation with Maria Kihl, Department of Electrical and Information Technology, Lund University. Martin Kjær defended his PhD thesis, "Disturbance Rejection and Control in Web Servers", in November 2009. External examiner was Prof. Tarek Abdelzaher, UIUC, US.

We are working on control of network server systems along two parallel lines.

Admission Control

In a collaboration with the Dept. Telecommunication at Lund University we study admission control schemes. In this project we consider modeling of network service control nodes and the use of nonlinear control theory for analysis and design of admission control schemes.

In the last couple of years "Communication and Control" has gained large attention and a lot of new research has focused on control of and over networks. However, the admission control problem, which is important for the utilization and the robustness of the network still remains as

an rather unexplored area. Here, we believe the interaction of queuing theory and nonlinear control play a major role.

During the project a discrete-time model of server nodes has been found which aligns well with the properties of the discrete-event models from the queuing theory. The different control algorithms and the effect of different arrival and service process distributions are evaluated experimentally on an Apache web server in a laboratory network. A traffic generator is used to represent client requests. The control of the Apache server has been re-written to implement our algorithms. We show that the control theoretic model aligns well with the experiments on the web-server. Stability analysis and controller design for both continuous and discrete-time models are considered.

Service Rate Control

We study service rate control of web-servers. An control scheme based on feedforward using an instantaneous queue model together with event-based PI feedback has been developed.

Periodic and Event-Based Control over Networks

Researchers: Anton Cervin, Toivo Henningsson, Erik Johannesson and Karl Johan Åström. Duration: January 2006 – December 2009

Funding: Swedish Research Council (VR)

In this project, we investigate the timing aspects of networked control and focus on the interplay between network scheduling and control performance. We study the fundamental trade-offs that exist between sampling rates, delays, and jitter in networked control. We want to be able to answer questions such as "What level of control performance can be achieved using time-triggered vs priority-based communication protocols?", "How can impact of network-induced jitter be handled in control design?", and "How can primitives suitable for control be included in existing and new communication protocols?"

A very promising approach to more efficient usage of the network bandwidth is event-based control. The idea is to communicate measurement and control signals only when something unexpected and significant has happened in the system. We are investigating how this approach compares to ordinary, periodic control, and how event-based sampling and control can be incorporated in network scheduling algorithms.

During 2009 we have investigated event-based PID control, exploring various discretization methods, limit cycle detection, and gain adaptation. In another line of research, we have been developing sub-optimal event-based reset controllers for higher-order systems. The results of the project so far were presented in a PhD course at the Universidad Politécnica de Valencia. During the year, a major revision of the TrueTime toolbox for simulation of networked control loops has also been undertaken.

Process Control

PID Control

Researchers: Karl Johan Åström, Olof Garpinger, Tore Hägglund, and Per-Ola Larsson

This project has been in progress since the beginning of the eighties, and resulted in industrial products as well as several PhD theses. Three monographs on PID control that are based on experiences obtained in the project have also been published. The last is "Advanced PID Control", published in 2005. It is also translated to Spanish 2009: "Control PID avanzado". The research is currently focused on the following topics:

A Simple Dead-Time Compensator

In this part of the project we are considering an ordinary PI(D) controller extended with a dead time compensator structure similar to a Smith predictor. The motivation for the project is that this new controller structure may be as easy to tune as a PI(D) controller, provided that model-based tuning rules are used. The performance of the new controller will be compared with the performance of the PID controller. The closed loops will be required to fulfill certain degrees of robust stability and performance and have a limit on control signal variance induced by measurement noise. The minimization criteria at the controller design is the integrated absolute error (IAE).

Relation Between Control Signal Properties and Robustness Measures

In a realistic setting, fast response to load upsets are restricted by e.g. limitations on actuator devices, noise characteristics of measured signals, and process variations. Thus, this should be incorporated in the design of a controller. An analysis concerning the optimization constraint in the PID design in this project and in the project "Decentralized Structures for Industrial Control" has been performed. It has shown that analytical expressions relating the M_S and M_T circles and the control signal magnitude and activity exist to a certain extent. Large robustness margins give small control signal activities and the opposite holds for small ro-

bustness margins. Thus, the proposed PID parameter optimization do take required control signal properties into consideration.

Software Tools for Design of PID Controllers

A new, interactive and easily modifiable software tool for robust PID design has been developed at the department. The tool has been programmed in Matlab and the goal is to find the controller that minimizes the IAE value during a load disturbance, while applying robustness constraints in terms of M-circles. The program has been made with focus on being user-friendly as well as robust and will hopefully be included in an educational autotuner in the future. The figure on this page shows a plot from the program, depicting the IAE cost as a function of the integral time and the derivative time in a PID controller. The minimum is shown by the yellow mark in the figure.

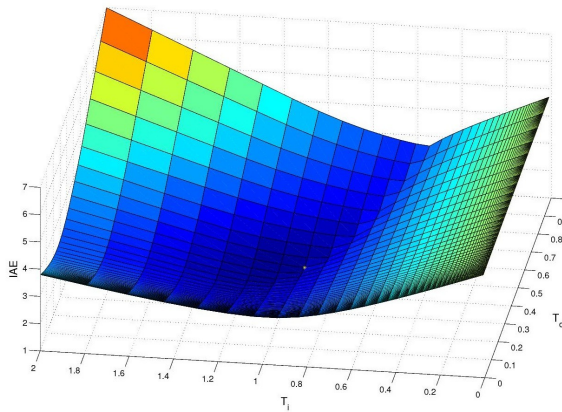

Surface plot from the PID design tool

The research is currently aimed at making the software suitable for control of real plants. This is achieved by tuning the time constant of a lowpass filter acting on the measurement signal. The purpose is to set a bound on the variance of the control signal, induced by measurement noise. By this modification, it becomes safe to include the D-part without fear of receiving a noisy control signal, wearing on the actuators. The new method will, however, only use a D-part if it is justified. In many

cases, a PI controller has been shown to be quite sufficient. Tests have also been carried out to give a more general idea for which types of processes a PI or PID controller are performing well compared to more advanced controllers. Just as well as examining when a PID controller is preferred to a PI controller. The conclusion was that this will be related both to the dynamics of the process and to the maximum allowed control signal activity.

We have decided to make the software tool, that was presented on IFAC World Conference in 2008, free for anyone to download. The Matlab files contained in the zip-file will make you able to design a robust, optimal PID (or PI) controller within seconds. The main function to run is `designpid.m` and you can use the Tutorial that is included as an introduction on how the program works. The software has been tested on Matlab 7 and may need some changes if it is not run under that version.

Interacting Learning Modules for PID Control

We are also developing interactive learning modules for PID control. The modules are designed to speed up learning and to enhance understanding of the behaviour of loops with PID controllers. The modules are implemented in SysQuake, and the work is done in collaboration with professor Sebastián Dormido at UNED, Madrid, and José Luis Guzmán at Universidad de Almería. The tools can be downloaded at <http://aer.ual.es/ilm/>

Upset Management — Developing methods for handling plant-wide disturbances

Researchers: Anna Lindholm, Charlotta Johnsson, Lund University.

The fraction of time a plant produces, the availability, is an important measure of the efficiency of a plant. High availability implies a possibility for large production volume and thereby increased profit for the company.



In this research project we are aiming to increase the availability by eliminating, or minimizing the effect of disturbances. The focus is on plant-wide disturbances such as variations in cooling water temperature or steam pressure to the entire plant. The goal is to develop a generic

strategy for handling plant-wide disturbances in complex plants in order to increase availability. A case study is performed at Perstorp AB, site Stenungsund.

The project is part of the Process Industrial Centre at Lund University, PIC-LU.

Decentralized Structures for Industrial Control

Researchers: Olof Garpinger and Tore Hägglund

There is an unfortunate gap between the centralized computational approaches of multi-variable control theory and the common practice to design local control loops disregarding couplings and interaction. Today it appears that both approaches has reached a point of refinement where the gap can be reduced from both sides.

This project aims to revise and improve the basic modules for decentralized control, and to develop new. By increasing the performance of the modules, the usefulness of present MIMO control functions such as MPC will increase. In this way, we will try to decrease the gap between MIMO control functions and the state of the art of process control. The ideas to be investigated in this project are relevant not only for process control but is also of interest for general classes of multi-variable systems. .

In a first stage, we will develop a new module building on experiences from PID control: a TITO controller, i.e., a controller with two inputs and two outputs. To be accepted in process control, the TITO controller will be fully automatic without any parameters to be set by the user. It means that an automatic tuning procedure has to be developed.

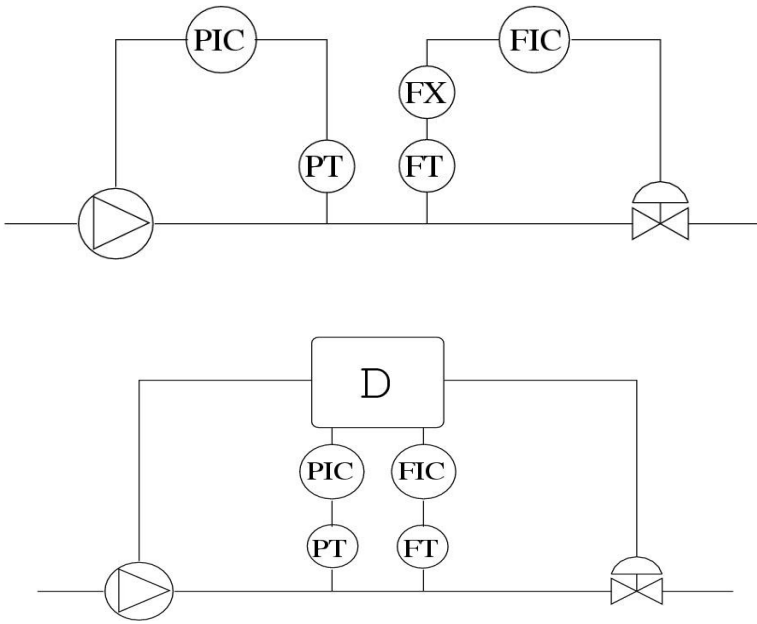

Conventional control of coupled systems (upper)
and control with decoupling (lower).

In a first phase, a decoupling procedure and a new PID design method have been developed. The decoupler is dynamic, but the goal has been to introduce as little dynamics in the decoupler as possible. Traditional PID design methods are not suitable for decoupled systems. For this reason, a new design method based on exhaustive search has been derived. The work in this first phase has resulted in a licentiate thesis by Pontus Nordfeldt.

During 2009, collaboration has been established with University of Córdoba. An alternative decoupling structure, inverted decoupling, has been investigated. This structure has several important advantages compared with conventional decouplers, especially when it comes to implementation of the TITO controller. Using inverted decoupling, it is possible to implement the decoupling using standard blocks in most DCS systems just by adding feedforward signals to the two PID controllers. Industrial collaboration has also been initiated in the project.

The project is funded by The Swedish Research Council (VR).

Performance Monitoring and Diagnosis

Researchers: Tore Hägglund and Per-Ola Larsson

A Performance Index Based on Control Specifications

In the summer 2007, a new project concerning diagnosis of control loops was initiated. The diagnosis is built around a so called performance index that indicates the health of the loop. A majority of the today available performance indices are related to optimal performance of the loop, with some underlying criteria such as minimum variance and LQG-control. In many situations it is impossible to meet such an optimal criteria due to e.g. lack of process knowledge, requirements of a too heavy control signal activity, and restricted control structure. Instead, the aim of this ongoing project is to develop a performance index that is related to a specified satisfying control performance that is possible to meet. The initial tuning of the loop is used as reference in the index calculation. Although, explicit controller structure and parameters are not to be known by the index algorithm, neither is any a priori knowledge of the process assumed available. In the project, it has been shown that modeling of the closed loop using only process output data, gives an opportunity to calculate such an index.

Backlash Estimation

Stiction and backlash in control valves are the major problem at the loop level in process control plants. There are two aspects of the problem. First of all, the nonlinearities deteriorate the control performance. Secondly, the loops facing these problems often remain undiscovered by the personnel in process control plants. There are several procedures for automatic stiction detection available and used in industrial plants today.

A new method for detection and estimation of backlash in control loops has been developed. The detection procedure is based on normal operating data. It is not assumed that the output from the backlash is measured. The procedure is automatic in the sense that no information has to be provided from the user to run the procedure. Since an estimate of the dead band caused by the backlash is provided by the procedure, the procedure gives all information needed to compensate for the backlash. The procedure has been tested in industry and a MS project has been performed in collaboration with ABB to prepare for implementation in an industrial DCS system. The method is patented.



Process Industrial Centre at Lund University

Researchers: Johan Åkesson, Tore Hägglund and Charlotta Johnsson

With support from the Swedish Foundation for Strategic Research (SSF), a new centre, PIC-LU, has been established in collaboration with the department of Chemical Engineering.

The overall goal of PIC-LU is to establish, in cooperation with Swedish process industry, an internationally leading centre for research and professional training in process optimization and control.

In the research program, methodology and tools for modelling, optimization, and control of industrial processes will be developed, in order to improve production systems with respect to flexibility, controllability, and availability. The methodology and the tools are developed from specific solutions to process control problems suggested by the industrial partners. The goal is to make the results from PIC-LU industrially relevant, not only for the participating industries, but on a wide scale in process operation and automation. The first industrial partners are Borealis, Novo Nordisk, Perstorp, and Pfizer.

In the competence development program, the main goal is to increase the competence level of process optimization and control in industry as well as in academy. The goal will be reached in two ways; through an educational program at different levels for staff in process industry, and by directed efforts in MSc and PhD programs at the university.

PID Autotuning based on Optimization and Nonlinear Feedback

Researchers: Kristian Soltesz, Tore Hägglund, Karl Johan Åström, Lund University.

Within process industry, a large number of processes can be accurately modeled using simple models, i.e. SISO FOTD or SOTD.

In order to control FOTD or SOTD, it is often sufficient to use the PID controller. It is desired to choose PID parameters yielding a closed loop system with robustness towards load and measurement disturbances.

We aim at developing a methodology for automatic tuning of PID controllers, using nonlinear feedback for identification input generation and optimization based methods for both process parameter identification and controller synthesis.

The main components of the auto-tuning algorithm are the following.

- Generate identification input with little or none a priori system information
- Transfer function parameter identification through cost optimization
- Model verification
- PID synthesis
- Performance evaluation

The project is part of the Process Industrial Centre at Lund University, PIC-LU.

Modeling and Optimization of Grade Changes for Polyethylene Reactors

Researchers: Per-Ola Larsson, Niklas Andersson (Chem. Eng), Johan Åkesson, Tore Hägglund, Bernt Nilsson (Chem. Eng).

In this project, which is a collaboration with Borealis AB, we are considering grade changes for a chain of polyethylene reactors. In chemical industry today, the market is changing rapidly both in raw material pricing but also in product demand. To have the ability to perform fast and safe grade changes and thus adapting to the market is highly advantageous. One part of the project is to develop physical models of the three polyethylene reactors at Borealis' Stenungsund site, see Figure 1.

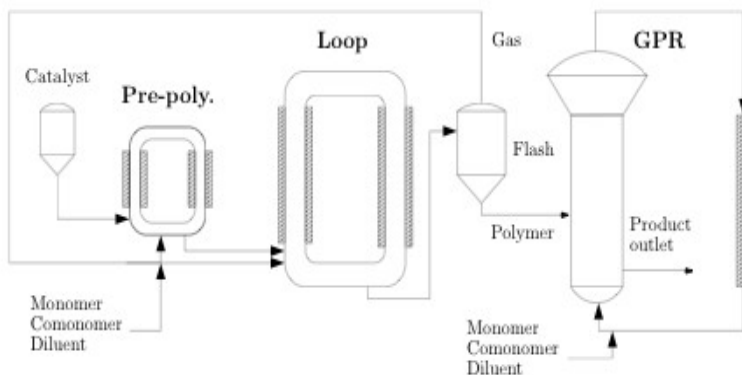

Fig.1 Reactor chain of a Borstar® process: Prepolymerization, Loop and a Gas phase reactor (GPR).

Using both well known physical laws and empirical relations, together with models derived for a non-linear MPC controller used at site today, a model library has been initiated. The library is developed in the Modelica language and includes both reactor models and framework models for optimization and validation. The second part of this project is optimization of grade changes using the models in the library. In the optimization, which is non-convex, both limitations of the reactors, but also economics, safety, time, and parameters defining the desired grade needs to be considered. Using JModelica.org, which is a framework for dynamic optimization of Modelica models, grade change optimization problems can be solved. JModelica.org incorporates Optimica, which extends the Modelica language with constructs to encode optimization problems. During 2009, the core of the library was built. A first optimization of a grade change for a single reactor has been performed successfully and submitted for publication. Model calibration using measurements has been initiated at the Chemical Engineering Department using a computer cluster.

Robotics

Robotics offer both theoretical and practical challenges. Robotics is a multi-disciplinary topic and we collaborate with both national and international robotics colleagues regarding different aspects of robotics and we also have a close cooperation with industrial partners. Our main research are in motion and compliance control, control system architectures and different sensor fusion problems with application mainly to industrial manipulators. We use mainly modified and extended ABB robot control systems as experimental platforms.

The laboratory for robotics and real-time systems is centered around Gantry-Tau robot L1 a Robotics lab, LTHd industrial manipulators with open control system architectures. In the lab we have an ABB IRB6 robot, an ABB IRB2000 robot, an ABB IRB2400 (S4CPlus) and an ABB IRB140 (IRC5). Hardware interfaces have been developed to create an open system suitable for control experiments. The computer hardware is either VMEbased with both microprocessors and signal processors integrated into an embedded system for hard realtime control in one of the labs and integrated with an additional PCI-based G4 PowerPC for the new Open Control system based on S4CPlus.

The systems are connected to a network with workstations, which are used for program development and control design. A purpose of the current project is to show how to organize open robot control systems and to verify these ideas by means of experiments.

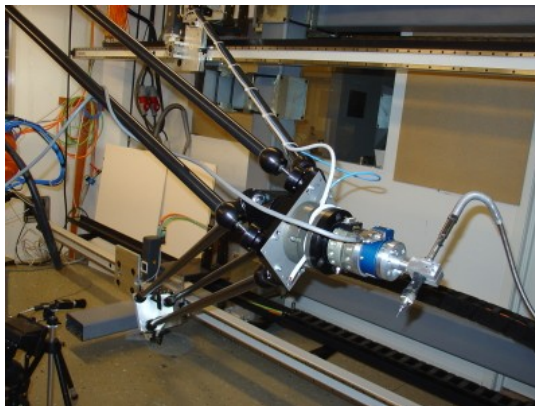

One goal is to permit efficient specification and generation of fast robot motions along a geometric path which requires coordinated adjustment of the individual joint motions. Another aspect of robot motion control is how to integrate simultaneous control of force and position according to ideas of impedance control in which stability is an important theoretical issue. A major topic in this project is to integrate aspects of control, sensor fusion and application demands using robot vision and force sensing. Another project is on the structure and programming of control systems for industrial robots. The problem addressed is how the software architecture and the realtime structure of a robot control system should be designed to allow easy and flexible incorporation of additional sensors and new control algorithms.

A software layer between a supervisory sequence control layer and the basic control level has been proposed. Case studies and prototype experiments show promising results and further implementation is going on. The project Autofett aimed towards use of force control in manufacturing operations such as robotized fettling and is now continued in the SMErobot and FlexAA-projects. New sensor interfaces with modification of hardware and realtime software architectures have been developed to accommodate the use of force control algorithms based on workspace sensing.

Several research interests are represented in Robotics Lab:

- Open Control Software Architectures
- Force controlled deburring
- Exteroceptive Robots
- Force Control
- Robot Vision
- Sensor Fusion
- Adaptive and Iterative Learning Control
- Task-level Programming
- Productive Robotics & Work-space Sensing

Robot control systems and other manufacturing equipment are traditionally closed. This circumstance has hampered system integration of manipulators, sensors and other equipment. As a result, such system integration has often been made at an unsuitably high hierarchical level.

The purpose of past and present projects is to show how to organize open robot control systems and to verify these ideas by means of experimental verification. As a part of this research, we have developed several

experimental open robot control systems. The systems are built around industrially available robots that have been reconfigured for experimental purposes.

The developed specific robot interfaces and the integration of the robots into a complete system forms a unique environment for testing and development of algorithms for improvement of performance, sensor integration, programming automation and autonomous operation.

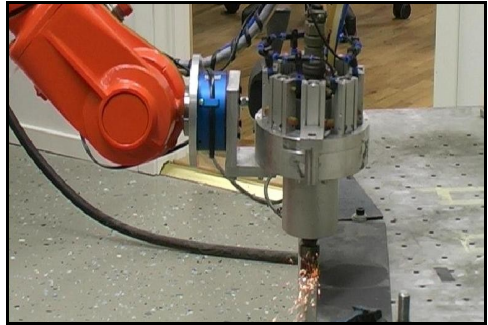

Productive Robotics @ LTH

Researchers: Klas Nilsson, Rolf Johansson, Gunnar Bolmsjö and Karl Åström, Mats Alaküla

Research Direction

Several research interests are represented in Robotics Lab:

- Open Control Software Architectures
- Exteroceptive Robots
- Force Control
- Robot Vision
- Sensor Fusion
- Adaptive and Iterative Learning Control
- Task-level Programming

Robot control systems and other manufacturing equipment are traditionally closed. This circumstance has hampered system integration of manipulators, sensors

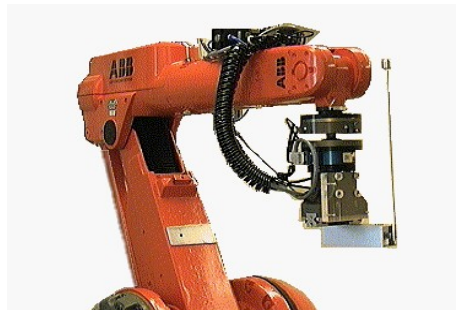

and other equipment. As a result, such system integration has often been made at an unsuitably high hierarchical level.

The purpose of past and present projects is to show how to organize open robot control systems and to verify these ideas by means of experimental verification.

As a part of this research, we have developed several experimental open robot control systems. The systems are built around industrially available robots that have been reconfigured for experimental purposes.

The developed specific robot interfaces and the integration of the robots into a complete system forms a unique environment for testing and development of algorithms for improvement of performance, sensor integration, programming automation and autonomous operation.

SMErobot™

Researchers: Isolde Dressler, Rolf Johansson, Anders Robertsson and Anders Blomdell in cooperation with Anders Nilsson, Dept. Computer Science; Karl Åström, Rikard Bertilsson, Fredrik Kahl, Dept. Mathematics, Lund University, and Dr. Torgny Brogårdh, ABB Robotics.

The project SMErobot is lead by Fraunhofer - Institut für Produktionstechnik und Automatisierung (IPA) and other project partners include GPS Gesellschaft für Produktionssysteme GmbH, Pro-Support B.V., ABB Automated Technologies Robotics, COMAU S.p.A., KUKA Roboter GmbH, Reis Robotics GmbH & Co. Maschinenfabrik, Güdel AG, Casting technology International LTD by Gurantee, Visual Components Oy, Rinas ApS, SMEEIG EESV, Prospektiv Gesellschaft f. betriebliche Zukunftsgestaltung GmbH, Fraunhofer - Institut f. Produktionstechnik und Automatisierung (IPA), German Aerospace Center - Institute of Robotics and Mechatronics, University of Coimbra / ADFF, Istituto di Tecnologie Industriali e Automazione, Fraunhofer - Institut f. Systemtechnik und Innovationsforschung (ISI).

SMErobot is an Integrated Project within the 6th Framework Programme of the EC to create a new family of SME-suitable robots and to exploit its potentials for competitive SME manufacturing.

The Need

More than 228 000 manufacturing SMEs in the EU are a crucial factor in Europe's competitiveness, wealth creation, quality of life and employment. To enable the EU to become the most competitive region in the world, the Commission has emphasized research efforts aimed at

strengthening knowledge-based manufacturing in SMEs as agreed at the Lisbon Summit and as pointed out at MANUFUTURE-2003. However, existing automation technologies have been developed for capital-intensive large-volume manufacturing, resulting in costly and complex systems, which typically cannot be used in an SME context. Therefore, manufacturing SMEs are today caught in an 'automation trap': they must either opt for current and inappropriate automation solutions or compete on the basis of lowest wages. A new paradigm of affordable and flexible robot automation technology, which meets the requirements of SMEs, is called for.

Breakthrough

This initiative is intended to exploit the potentials of industrial robots, because they constitute the most flexible existing automation technology. The consortium is set to create a radically new type of robot system - a whole family of SME-suitable robots.

Objective

The SMErobot initiative offers an escape out of the automation trap through:

- Technology development of SME robot systems adaptable to varying degrees of automation, at a third of today's automation life-cycle costs;
- New business models creating options for financing and operating robot automation given uncertainties in product volumes and life-times and to varying workforce qualification.
- Empowering the supply chain of robot automation by focusing on the needs and culture of SME manufacturing with regard to planning, operation and maintenance.

Innovations

Research and development in SMErobot is geared towards creating the following technical innovations:

- Robot capable of understanding human-like instructions (by voice, gesture, graphics)
- Safe and productive human-aware space-sharing robot (cooperative, no fences)

- Three-day-deployable integrated robot system (modular plug-and-produce components)

Partners

Five major European robot manufacturers have joined forces in SMERobot, in close cooperation with key component manufacturers, five leading research institutes and universities, and consultants for multidisciplinary RTD, dissemination and training efforts.

Implementation

Demonstrations of fully functional prototypes will be set up in different SME manufacturing branches (plastics & rubber, small-batch foundry, metal parts fabrication, etc.), together with SME end users and SME system integrators, partly from the new Member States. Training and education will be conducted at all levels from researcher to end-users.

Integration

SMEs and society benefit from the combined integration of knowledge along the supply chain of robotic automation, from component manufacturers to end users, from multidisciplinary activities to business/financing models, and from fundamental technical research when confronted with SME scenarios. Management includes dedicated support for SME integration.

For more information, see the SMERobot homepage:
www.smerobot.org

ROSETTA—Robot control for Skilled ExecuTion of Tasks in natural interaction with humans; based on Autonomy, cumulative knowledge and learning

Researchers: Rolf Johansson, Magnus Linderoth, Anders Robertsson. Members (in alphabetical order): ABB AB (Sweden, Coordinator), ABB AG (Germany), Dynamore GmbH (Germany), Fraunhofer IPA (Germany), K.U. Leuven (Belgium), Ludwig-Maximilians-Universität Munich (Germany), Lund University (Sweden), Politecnico di Milano (Italy).

Funding: Integrated project funded under the European Union's Seventh Framework Programme (FP7), (Ref. FP7 ICT-230902 ROSETTA).

The ROSETTA research project develops technology for industrial robots that will not only appear more human-like, but also cooperate naturally with human workers. This project is funded by the European Union under the FP7 grant 230902.

The following 4 objectives are set forth:

- to enable robots to be used in complex tasks with high flexibility and robustness;
- to ease the deployment effort to allow fast production changeover from product A to product B;
- to produce an easy-to-use programming system to access ROSETTA robot functionality without the need for highly skilled robot programmers;
- to provide new sensing, control and decision making methods for safe physical human-robot interaction.

ROSETTA is the acronym for a new European Large-Scale Integrating Research Project “RObot control for Skilled ExecuTion of Tasks in natural interaction with humans; based on Autonomy, cumulative knowledge and learning”. The 4-year project started March 1st, 2009, and has a total budget of 10 MEUR.

Goals

ROSETTA develops “human-centric” technology for industrial robots that will not only appear more human-like, but also cooperate with workers in ways that are safe and perceived as natural. Such robots will be programmed in an intuitive and efficient manner, making it easier to adapt them to new tasks when a production line is changed to manufacture a new product.

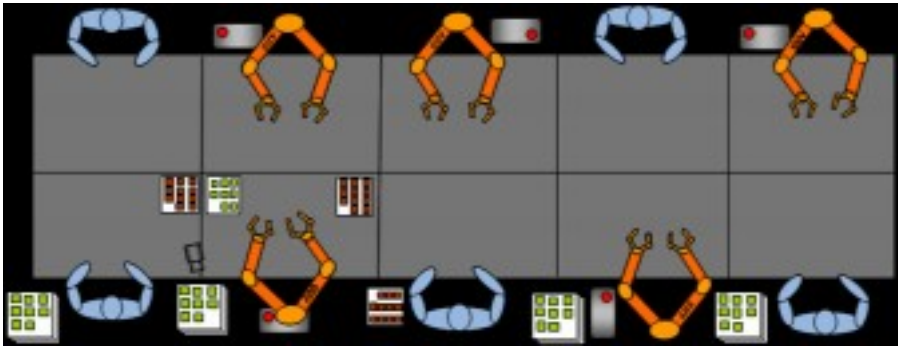

Key Issues

The need for such robot systems stems from analyses showing that future factories will produce more and more goods with high volumes, but with many variants and limited product lifetime. This requires a flexible manufacturing system allowing for frequent production changes. Robot systems are the automation method of choice to meet these demands, but they need the ability to adapt even more quickly to new tasks, and to obtain full production output faster than today. Also, it is mandatory to easily integrate robots into manufacturing lines with human workers, as the combination of manufacturing by humans and robots promises highest flexibility. Tasks difficult to automate will in this scenario remain the domain of humans, whereas operations with low automation threshold or high quality requirements will be performed by these robots.

Scientific / Technical Approach

The project will address the challenges by developing methods to engineer and program robot systems in ways that are more intuitive, more related to the task, and less specific to the installation. This will require robots to be able to execute tasks more autonomously, without the need for detailed description of every step, and will lead to a significant reduction in programming effort. Once programmed, the robots will use sensor-based learning to autonomously improve their abilities (“skills”) to perform the task quickly, quite like a human worker. When the operation is optimized in this way, the robot shares the knowledge of how to best perform the operation with other robots by sending the parameters over a

network to a central server. Other robots do the same, which results in a quick build-up of production knowledge (“cumulative learning”). Storing and sharing production-related data will make use of latest techniques developed for the Web 2.0, representing such data as form of 'knowledge' that can be accumulated, enhanced and re-used by a population of robots.

The production scenario that involves robots and humans working side-by-side and interacting safely requires that design, control and supervision devices and methods are found for robots to be harmless, and to act in a way that humans anticipate and feel comfortable with. This involves developing human-like motion patterns, speech interaction as well as avoidance of any situation that may pose a hazard or uncomfortable situation to human workers or operators. The human-machine cooperation will be supervised by a multi-level sensor system involving different sensor types and a reasoning unit that will analyze the robot environment and give the robot instructions in real-time how to adjust to changing environments and to human presence.

Expected Impact

The engineering and production methods will make robot automation accessible for a variety of new applications, in particular where production is frequently adapted to new product lines. This will enable the European industry to increase its competitiveness by reducing production cost and by increasing production quality. A thorough understanding and modeling of the human/robot contact and interaction in a production scenario are major efforts of ROSETTA. The theoretical and experimental investigations will lead to injury risk classifications with the goal of creating future safety standards for human-robot cooperation, helping the industry to better utilise the potential of robots working in human environments.

Automotive Systems

Projects devoted to vehicle dynamics and combustion control run in cooperation with major car manufacturers.

Diesel HCCI in Multi-cylinder Engines

Researchers: Maria Karlsson and Rolf Johansson in cooperation with Kent Ekholm, Prof. Bengt Johansson, Dr. Per Tunestål, Div. Combustion Engines, Lund University, and Johan Dahl, Petter Strandh, Stefan Strömberg, Volvo Powertrain, Inc.

Homogeneous Charge Compression Ignition (HCCI) is a hybrid of the spark ignition and compression ignition engine concepts. As in an SI engine, a homogeneous fuel-air mixture is created in the inlet system. During the compression stroke the temperature of the mixture increases and reaches the point of autoignition, just as in a CI engine. One challenge with HCCI engines is the need for good timing control of the combustion. Auto ignition of a homogeneous mixture is very sensitive to operating condition. Even small variations of the load can change the timing from too early to too late combustion. Thus, fast combustion timing control is necessary since it sets the performance limitation of the load control. This project deals with various approaches to feedback control of the HCCI engine for optimized fuel economy and low emissions. A 12-liter Volvo Diesel engine has been successfully converted to HCCI operation with feedback systems based upon feedback of measured cylinder pressure or ion current.

Among control methods successfully applied, linear quadratic Gaussian control and model-predictive control have been implemented and tested.

During 2009 work focused on low-emission diesel combustion, a combustion mode between traditional diesel combustion and HCCI. Using relatively early fuel injection combined with a large amount of recycled exhaust gases (EGR), the combustion process is more homogeneous than in traditional diesel combustion, which has a large impact on emissions. Namely, NO_x emissions are drastically decreased while soot emissions are increased.

In such a combustion mode, the engine controller must meet several objectives simultaneously - high efficiency, reliable combustion, and low

emissions of both NO_x and soot. Several actuators are available to meet the specifications, and multiple input multiple output (MIMO) control is necessary. In the project, model predictive control (MPC) has been investigated as a way to systematically go from high-level specifications on torque response, combustion timing, and emissions to a control algorithm. Particularly, we have investigated what can be achieved using direct on-line measurements of emissions for the controller instead of indirect measurements combined with empirical maps which is common practice today.

This project is financially supported by Volvo Powertrain, Inc., and the Vinnova PFF program (VINNOVA-PFF Ref. 2005-00180).

KCFP, Closed-Loop Combustion Control

Researchers: Rolf Johansson, Anders Widd in cooperation with Assoc. Prof. Per Tunestål and Prof. Bengt Johansson, Div. Combustion Engines.

Competence Center Combustion Processes at Lund University focuses on research of combustion processes between conventional HCCI (Homogeneous Charge Compression Ignition) and classical Otto and Diesel engines.

Project aims:

- System identification of combustion processes under closed-loop control;
- Development of algorithms hardware implementation suitable for ASICs and FPGA;
- Control-oriented modeling and simulation of combustion processes.

In addition to aspects of modeling related to thermodynamics, chemical combustion kinetics, and engine operation, careful attention is required for control-oriented combustion modeling and the interactions among dynamics, control, thermodynamics and chemical combustion properties. Modeling of engine-load transients as well as thermal transients also belong to this important domain of modeling. Progress in this area is important and necessary for successful and robust control such as model-predictive control.

Within the project a cycle-resolved, physics-based, model of HCCI has been developed. The model includes a low-complexity model of the cylinder wall temperature dynamics in order to capture the relevant time-scales of transient HCCI when only small amounts of hot residuals are trapped in the cylinder. The temperature evolution of the gas charge is

Chapter 5. Research

modeled as isentropic compression and expansion with three heat transfer events during each cycle.

During 2009, work focused on design and evaluation of model predictive controllers based on linearizations of the model. The considered control signals were the inlet valve closing and the intake temperature. Simulations were used for the initial control design and the resulting controller was tested experimentally. The control performance was evaluated in terms of response time to set-point changes and the resulting output variance.

It was found that a comparable decrease in the output variance in some operating points could be achieved either by introducing a disturbance model or by changing linearization. All tested set-point changes were accomplished within 20 engine cycles or less. Only minor changes to the intake temperature were required for moderate changes. The closed-loop system showed good robustness towards disturbances in engine speed, injected fuel energy, and the amount of recycled exhaust gases.

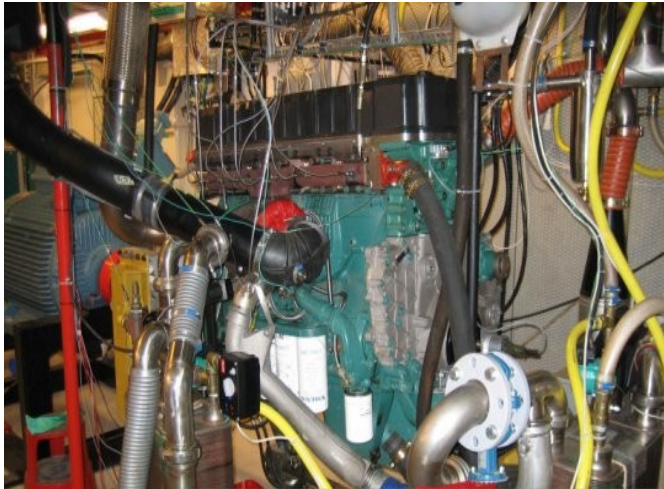

Biomedical Projects

Cardiologic Analysis and Modeling

Researchers: Rolf Johansson in cooperation with Prof. S. Bertil Olsson, Dr. Jonas Carlson, Dr. Pyotr Platonov, and Dr. Fredrik Holmqvist, Dept. Cardiology, Lund University Hospital, Lund University.

This project is directed towards chronic atrial fibrillation (CAF), one of the most common cardiac arrhythmias in man and associated with increased morbidity and mortality. Previous studies in animals have shown that experimental atrial fibrillation is based on different types of intraatrial electrical reentry. By exploring the activation of the right atrial free wall during open-heart surgery in patients with CAF and an underlying heart disease, we confirmed the presence of reentry mechanisms. In addition, areas with organized activation were identified. The nature of the organized activation suggested reentry in an anatomical structure, like the right annular bundle surrounding the tricuspid valve. In patients without signs of organized activation, multiple activation waves continuously reenter due to functional properties of the atrial myocardium. An interesting result was that we failed to demonstrate that anisotropy in conduction velocity be a general property of the epicardial right atrial free wall of the intact human heart in patients with stable sinus rhythm as well as in patients with CAF.

Balance Laboratory

Researchers: Rolf Johansson in cooperation with Prof Måns Magnusson, Dr. Per-A. Fransson and Dr. Mikael Karlberg (Department of Clinical Sciences, Div. Otorhinolaryngology, Lund University Hospital)

The project is directed towards assessment of normal and pathological human postural control. System identification and mathematical modeling of the dynamics in postural control are studied with special interest on adaptation, reflexive and anticipatory control. Reflexive and voluntary eye movements are studied in patients with lesions related to balance disorders. Experimental studies, with special reference to the level of alertness, are undertaken to enhance understanding, diagnosis and treatment of dizziness and vertigo. A major complication is that human

postural control is characterized by multisensory feedback control (visual, vestibular, proprioceptive feedback) and this fact is reflected both in experiment design and analysis. Special interest is directed to the importance of cervical and vestibular afferent pathways. To this purpose, stability properties are studied by means of induced perturbations specific to each sensory feedback loop by using system identification methodology. The work is supported by the Scientific Research Council (Grant 2004-4656: Quantification of human postural control, reflexive eye movements and development of therapies for disturbed balance and dizziness) and the Faculty of Medicine, Lund University.



DIAdvisor

DIAdvisor™—Personal Glucose Predictive Diabetes Advisor

Researchers: Rolf Johansson, Mona Landin-Olsson (Lund University Hospital), Per Hagander, Marzia Cescon, Fredrik Ståhl and Meike Stemmann.

This project is co-funded by the EU through the ICT programme under FP7 (Ref. ICT-216592) European Commission—ICT for Health.

The DIAdvisor™ is a large-scale integrating project (IP) aiming at the development of a prediction based tool which uses past and easily available information to optimize the therapy of type I and developed type II diabetes. The DIAdvisor™ is not dependent on specific sensor technologies and can be adapted to technologies like standard strip sensing, minimally-invasive continuous glucose sensors and emerging non-invasive methods.

For safety reason, the DIAdvisor™ system will be able to self-assess the confidence of its proposed decisions. For safety reasons as well as for the sake of therapy improvements, the system connects and provides information and trends to the Health Care Provider.

Glucose prediction is difficult and requires advanced science within the fields of physiological modeling, identification theory, control theory, medical device technology, risk management theory, sensor science and user understanding. It can be achieved only by a well balanced group of eminent experts, including academics, clinicians, user representatives and leading companies.

The expected impact of DIAdvisor™ will be improved diabetes control and quality of life in large populations of insulin treated patients, leading

to fewer diabetic complications and lower Health Care costs. Moreover, the project will constitute a valuable opportunity for European companies to build up a special know-how leading to products that profoundly and positively have an impact on the lives of millions of people with other indications than diabetes.

Tools

A large number of software tools for analysis, design, and simulation of control systems have been developed at the department since the 1970's. Below we list tools that are being actively developed or maintained at the current time. The tools are free software and can be downloaded from the department web page.

TrueTime: Simulation of Networked and Embedded Control Systems

TrueTime is a Matlab/Simulink-based simulator for real-time control systems. TrueTime facilitates co-simulation of controller task execution in real-time kernels, network transmissions, and continuous plant dynamics. During 2009, a major revision of the simulator has been undertaken. New features include the FlexRay and PROFINET network protocols, built-in support for CBS scheduling, an ultrasound network block, and overall improved user friendliness.

Jitterbug – A Matlab toolbox for real-time control performance analysis

Jitterbug is a Matlab-based toolbox that allows the computation of a quadratic performance criterion for a linear control system under various timing conditions. Using the toolbox, one can easily and quickly assert how sensitive a control system is to delay, jitter, lost samples, etc., without resorting to simulation.

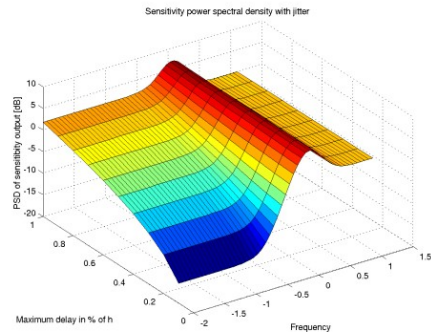

Grafchart

Grafchart is the name of a toolbox for supervisory level sequence control and procedure handling that has been developed at the department since 1991. Grafchart is based on ideas from Grafcet/Sequential Function Charts, Petri nets, Statecharts, and object-oriented programming.

The original version of Grafchart was developed in G2 from Gensym Corporation. Using this platform Grafchart was used for batch recipe control, diagnosis of mode-changing processes, alarm filtering, implementation of operator decision support systems, and implementation of robot cells. A collection of publications on Grafchart is available.

JGrafchart

In the beginning of 2001 a decision was made to switch to a Java-based implementation platform. The new version of Grafchart is therefore named JGrafchart.

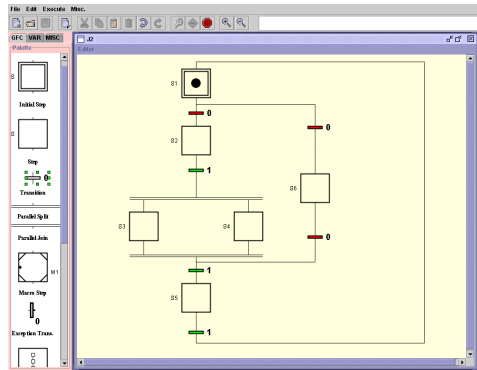

MPCtools: A toolbox for simulation of MPC controllers in Matlab

MPCtools is a freely available Matlab/Simulink-based toolbox for simulation of MPC controllers. MPCtools provides easy to use functions to create and simulate basic MPC controllers based on linear state space models.

JModelica.org

JModelica.org is an extensible Modelica-based open source platform for optimization, simulation and analysis of complex dynamic systems. The main objective of the project is to create an industrially viable open source platform for optimization of Modelica models, while offering a flexible platform serving as a virtual lab for algorithm development and research. As such, JModelica.org is intended to provide a platform for tech-

Chapter 5. Research

nology transfer where industrially relevant problems can inspire new research and where state of the art algorithms can be propagated from academia into industrial use. JModelica.org is a result of research at the Department of Automatic Control, Lund University, and is now maintained and developed by Modelon AB in collaboration with academia.

JModelica.org at a glance:

- Model your systems using the object-oriented and equation-based language Modelica
- Solve your complex simulation and optimization problems using state of the art numerical algorithms
- Automate your work in the Python scripting environment
- Visualize your results

```
Python
iter objective inf_pr inf_du lg(mu) |dj| lg(r) alpha_du alpha_pr ls
40 2.346908e+01 2.729e-011 2.34e-007 -11.0 1.33e-005 - 1.00e+000 1.00e+000 1
41 2.346908e+01 2.43e-011 2.34e-007 -11.0 8.85e-006 - 1.00e+000 1.00e+000 1
42 2.346908e+01 1.65e-012 2.34e-007 -11.0 8.91e-007 - 1.00e+000 1.00e+000 1
43 2.346908e+01 4.34e-013 1.40e-008 -11.0 9.11e-007 - 1.00e+000 1.00e+000 1
44 2.346908e+01 1.71e-013 8.15e-009 -11.0 2.44e-007 - 1.00e+000 1.00e+000 1
Number of iterations.... 43
Objective..... (scaled) (unscaled)
Dual infeasibility..... 2.346908013069623e+01 2.346908013069623e+01
Constraint violation..... 8.153888622714962e-009 8.153888622714962e-009
Complementarity..... 1.7053035658242404e-013 1.7053035658242404e-013
Overall NLP error..... 1.0000000000000000e+011 1.0000000000000000e+011
EXIT: Optimal Solution Found.
```

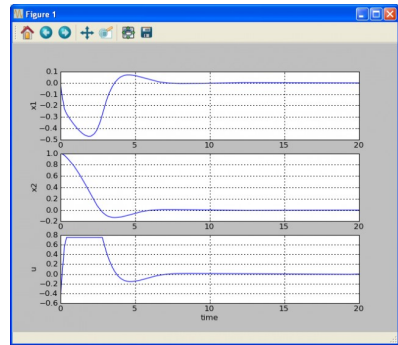

6. External Contacts

A healthy mix of fundamental and applied work is a cornerstone of our activities. In the applications projects the goal is to solve real control problems together with external partners. In these projects the problems are approached with an open mind without glancing at particular methods. One purpose is to learn about real problems, another is to learn about new problems that are suitable for theoretical research.

An important role for universities is to organize knowledge in such a way that the results can easily be digested by engineers in industry. There is naturally a strong symbiosis with teaching in this activity. A good mechanism is thus to introduce new research material into existing and new courses. A related form of technology transfer is to write books and monographs and to develop software.

Exchange of personnel between industry and university is another very effective vehicle for technology transfer.

Academic Contacts

We have very good and fruitful relations and cooperations with a number of universities and academic institutions throughout the world. This year we have had important contacts with

- Department of Computer Science, Lund University, Sweden
- Department of Electrical Engineering and Information Technology, Lund University, Sweden
- Department of Mathematics, Lund University, Sweden
- Department of Heat and Power Engineering, Lund University, Sweden
- Department of Mechanical Engineering, Lund University, Sweden
- Department of Cardiology, Lund University Hospital, Sweden
- Department of Clinical Sciences, Lund University Hospital, Sweden
- Department of Logistics, Lund University, Sweden

Chapter 6. External Contacts

- Universidad Politecnica de Valencia, Spain
- Umeå University, Sweden
- Jaen University, Spain
- Norwegian University of Science and Technology, Norway
- Universidad de Valladolid, Spain
- Universita di Roma, La Sapienza, Italy
- Universita di Siena, Italy
- Parades, Rome, Italy
- Herlev University Hospital, Copenhagen, Denmark
- Tsinghua University, Beijing, China
- Hanyang University, Korea
- Sung Kyun Kwan University, Korea
- Linköping University, Sweden

Korea-Sweden Robotics Symposium, Lund, June 8-9, 2009

On June 8-9, 2009, the Korea-Sweden Robotics Symposium was held at the Old Bishop Palace with participation of 35 scientists from leading centers of robotics in Korea and Sweden. The symposium was financed by institutional grants from STINT and it was co-arranged in Lund



by Prof. Anton Shiriaev (Umeå University), Dr. Klas Nilsson (Lund University, Dept. Computer Science), and Prof. Rolf Johansson (Lund University, Dept. Automatic Control). The invited scientists represented industry, research institutes and university research.

Major topics were surveys of the current significant Korean grant programs and research projects in robotics given in lectures by Prof. Il Hong Suh (Hanyang University) and Prof. Sukhan Lee (Sung Kyun Kwan University). Intelligent networked robotics, exogenous sensing, workspace perception, manipulation of 3D objects and action reasoning were major themes of the symposium.

Industrial Contacts

We have very good working relations with many companies and organizations. The interactions are at different levels and of different intensities, from visits and discussions to joint projects. Master's theses and education are also important ingredients. During the year we have had major projects with

- ABB Automation Technologies/Robotics
- ABB CRC Västerås
- ABB Corporate Research Sweden/Germany
- ABB Robotics Products, Västerås
- Boeing R&D
- Borealis AB
- Castings Technology International, England
- Ericsson
- Gudel AG, Switzerland
- KPS Rinas, Denmark
- Novo Nordisk AS
- Perstorp AB
- Pidab AB
- SKB Oskarshamn
- TetraPak
- Toumaz Technology Ltd, Abingdon, UK
- Volvo Powertrain, Inc

European Collaboration

During 2009 the department was involved in the 6th and 7th Framework Program of the European Commission.

FP6 Projects:

- ARTIST2 – Embedded Systems Design
- HYCON – Hybrid Control: Taming heterogeneity and complexity of networked embedded systems

Chapter 6. External Contacts

- EURON-II – European Robot Research Network
- SMErobot™

FP7 Projects:

- ACTORS
- AEOLUS
- ARTIST-DESIGN
- CHAT
- DIAdvisor™
- ROSETTA

7. Looking Back on Computers

A personal account of the computers at the Department of Automatic Control, told by Leif Andersson who had the system responsibility for many of them, and who designed a few of them.

*Jo, därom kan jag ge besked,
om herrn så vill, för jag var med*
Johan Ludvig Runeberg

This chapter describes old equipment, and a lot of the technology of this old equipment has fallen out of use. It is, however, well described in many places on the internet, and rather than repeating those descriptions here, the names are italicized and marked with an asterisk *like this**, for terms that have good descriptions on Wikipedia and other places as of this writing. The story ends around the year 2000, simply because it is too difficult to have a proper perspective on development too close to the present.

The Analog computers

Among the most important tools for research in Automatic Control is some kind of device for simulation of dynamical systems, i. e., the plant to be controlled and/or the controller. This was as true in the middle of the 1960s, when the Department of Automatic Control started, as it is today. The important difference is that in those days digital computers with suitable simulation software simply did not exist. Instead researchers used *analog computers**. These are electronic devices where different physical quantities may be represented by, typically, a voltage. There are

Chapter 7. Looking Back on Computers

circuits that can perform summation, integration, function evaluation, and other operations on these variable voltages. With suitable choices of the representations, dynamical systems may thus be simulated in real time or, if desired, in scaled real time.

When Karl Johan Åström started the department in 1965, he got the opportunity to buy, from the IBM Nordic Laboratory, a used analog computer of the highest quality. It was a PACE 16-231R, manufactured by Electronic Associates Inc., New Jersey in 1959. It used vacuum tube electronics in the operational amplifiers, and had a voltage range of ± 100 V. All important components were housed in a temperature controlled oven to minimize drift, such that the general accuracy of the computer was in the order of 0.01%. There were 100 operational amplifiers, 30 of which were integrators, which meant that systems with up to 30 states could be simulated.

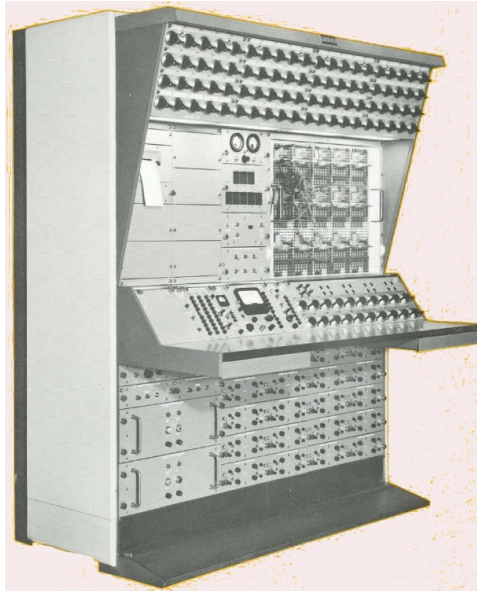

The PACE 16-231R. It is almost 2 m high

The results from the simulation runs were plotted on A3 paper on an x-y plotter, or on an eight-channel pen recorder. The difference is that

the first one plots two variables from the simulation against each other, while the other one has a strip of paper that runs with constant speed, so up to eight variables can be plotted against time.

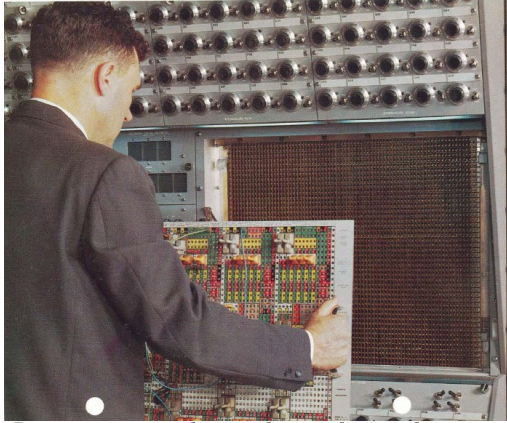

Inserting a patch panel into the analog computer

The simulation experiments were set up by connecting integrating elements to each other, possibly via nonlinear function elements, such as multipliers. Most connection paths also had potentiometers to set the various parameters of the simulation. Setting up the simulation in this fashion took quite a lot of time, and the simulation experiment could not be run until all connections were in place. In order to better utilize the most expensive equipment, the connections were set up on separate *patch panels* that could then be inserted in the computer as one single operation when a specific experiment was to be run. There were a number of such panels, so that one researcher could run a simulation, while others were setting up theirs on separate panels. The only thing that had to be changed for each different simulation was the entering of the parameters via potentiometer settings, and that was a reasonably quick operation.

Examples of research done on this analog computer are the Master's Theses by Ekstrand, Larsson (1966), by Borisson (1968) and by Andersson, Olofsson (1971). The thesis by Broqvist (1970) describes simulation of an ecological system rather than a technical one.

Small analog computers In the early 1970s the prices of analog integrated circuits went down, just like other electronics, and it became feasible to get multiple small analog computers for educational purposes.

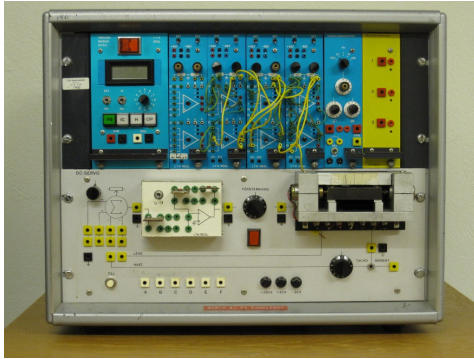

Small analog computer together with electromechanical servo. It is about 50 cm wide.

Since we had experience with a really high quality equipment, we decided to design and build them ourselves. The result was units suitable for laboratory exercises, with ten operational amplifiers, that could each be used as either integrators or summers. They were packaged in modules of two amplifiers, which could be exchanged with other modules, such as multipliers or noise generators, which were developed later. The components used in the amplifier modules were of a reasonably good quality, and we estimated that the overall accuracy was about 1%. We built totally eight of these units, and they were successfully used in lab exercises until the late 1980s.

The PDP-15

Useful as the analog computer may have been, it was clear to the department leadership that the future lay in digital computers, both from a scientific and from an industrial engineering viewpoint. Already in the late 1960s a considerable amount of research was done with the then common method of computing: The source program together with any input data was submitted to the university computer center, where it was to be compiled and run on the big and powerful computer system there. After some

time, typically a few hours to a day, the result could be retrieved. This result was then either the real result of a successful run, or a slightly humiliating message that there were more or less trivial formal errors in the source program. These errors were then corrected, the program and data resubmitted, and another wait started.

At that time so called minicomputers had started to emerge. They were less powerful than the big computers in the university data centers, but also much cheaper. If the department could have one of these minicomputers of its own, then the research computing throughput would increase, and even the new concept of *interactive computing* could be explored.

Even if the required amount of money was available to the department, it was not possible to just approach a number of suppliers requesting tender, and then to buy the system most suited. The Swedish government considered computers slightly sacred, and wanted full control over which state institution had what computing power. Knowledgeable advisors informed that it would be a lengthy and uncertain process for an individual department to be allowed to buy a general purpose computer.

There was a loophole though. One of the department's genuine research interests was process control by computers, an engineering field that was rapidly gaining momentum. The minicomputers that were typically used for process control were of the same type that the department wanted for general purpose computing. In the application to the central authorities to be allowed to buy a computer, the stated reason was therefore only research into process control by computers, not general purpose computing.

The application was granted, and the procurement procedure started. Among the bidders were companies such as Varian Data Machines, Hewlett Packard, Digital Equipment, Scientific Data Systems, and others. After a few months work the choice fell on a system from Hewlett Packard. All conditions were tentatively agreed, and the parties were gathered in Stockholm for the final signatures, when someone mentioned the phrase "delivery time guarantee". This simple phrase froze the whole procedure, because it turned out that the system offered was not at all available for delivery at that time.

The procurement procedure consequently had to be restarted, and this benefited Digital Equipment, because it meant that they could offer their newest machine, the PDP-15, which had its first deliveries in February 1970. With Hewlett-Packard out of the picture this machine was

the clear winner, and it was ordered for delivery in the middle of the year 1970.

During the spring of 1970 Johan Wieslander, who was to be System Manager, went to Maynard, Massachusetts, the headquarters of Digital Equipment Corporation, to attend courses and learn everything about the new computer. In late summer it finally arrived.

It was a PDP-15/35, the latest member of Digital's family of computers for process control. It had a word length of 18 bits, which meant that all registers were 18 bits long, and that all memory references operated on 18 bits of data. The main memory, of type magnetic *core memory**, was 16 kwords. There was a reader and punch for paper tape, at that time often the most important medium for input and output of data, and for transfer of data between different computer systems.

Off-line data was handled by two *DECtape** stations where the tape spools had a capacity of 144 kwords. These tape spools were inexpensive enough that anyone who worked on the computer could have their own personal DECtape for programs and data, much like the diskettes of later days.

This computer also had a disk with a capacity of 256 kwords. It should be noted that in those days a disk was in fact not as self-evident for a computer as it is today. The PDP-15 family started out in five models of different capacity, and only the two high end models had disks. The disk was also unlike modern disks, in that it did not have one head that could move back and forth over the surface, but instead had 128 heads, one per track, each one in a fixed position so that it could only move a few micrometers vertically.

The communication with the operator took place via a *teletypewriter**, an electromechanical typewriter that could write 10 characters per second. The main device was a Teletype KSR35, and for some reason there was also an extra teletypewriter, of type ASR33, which was less rugged, but had a paper tape reader and punch. The idea was probably that programs and data could be prepared off line on paper tape and then read in to the computer with the paper tape reader.

During subsequent years the machine underwent quite a lot of enhancements. The main memory was doubled to 32 kwords, and it got a new and bigger disk, this time a removable disk of 1.2 Mwords.

Cold Start and Warm Start When power was applied to the computer, the first thing that happened was that the console switches were read. Those were a set of about 50 switches that could be used to manu-



The PDP-15 Console

ally set the contents of registers and memory cells. If those switches were in the “warm start” position, and if a specially assigned part of the memory still contained its proper disk controller program, then the machine would start, and soon type out a “ready”- message on the teletype. If the memory contents was not right, however, it had to be restored. The normal way to do that was to locate a special piece of paper tape, carefully marked “Cold Start”, load that tape into the tape reader, enter a specific pattern into the console switches, and push Start. Normally the tape was then read in, and all conditions for a normal warm start was met, so the computer could start. If this piece of paper tape could not be located or was damaged, the only way to start was to enter a long sequence of binary numbers into the console switches and hope that no bit-mistakes were made. That particular cold start tape existed in many backup copies.

The Line Printer The console teletype could only write 10 characters per second, and that would have been far too slow to get out all needed computation results and program listings. Fortunately at that time the University Computer Center decommissioned their eldest computer (the first one in Lund, from about 1956), that had a *line printer**. It was agreed that our department could get that printer, and Johan Wieslander and Rolf Braun started to design and build the hardware and software needed to connect the printer to the computer. That work was finished in December 1970, and with a few later modifications to the electronics, the printer ran successfully for almost ten years.

Process Interface This computer was bought as a process computer, and it would indeed do a fair bit of process control. The most obvious form for interfacing to a physical process is a number of analog inputs and outputs. These were in fact ordered with the computer, and only some buffering electronics and physical connectors had to be built. The end result was 16 8-bit analog inputs ($\pm 10V$), 8 analog outputs and 16 digital inputs and outputs.

The Tektronix 611 Storage Monitor The traditional way to get the result out from a computer at that time was in the form of a table on the printer or possibly having the computer draw a curve directly onto a very expensive pen plotter. The second method was out of reach for a department like ours, and the first was really too slow and cumbersome for the type of interactive computing that the department envisioned. The solution came in the form of the Tektronix 611 Storage Monitor, a 24cm x 15cm screen where the computer could draw a curve or write text, that would stay on the screen by means of cleverly controlled static electricity, until it was deliberately erased. The intention originally was to use a *Polaroid camera** to get a copy of the picture on paper, but Tektronix announced a Hard Copy Unit, that could be connected to the Storage Monitor to read out the stored image and transfer it to paper. This

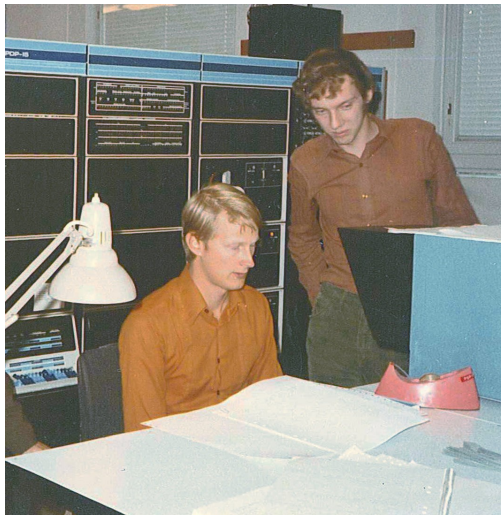

Johan Wieslander and Hilding Elmqvist in front of the PDP-15

computer peripheral combination worked very well all the time until its decommissioning ten years later.

Remote Control I The department's main research interests at that time were Adaptive Control and Process Control. A unique opportunity to combine these fields arose when a former master's thesis student, Rolf Syding, working in the research department of LKAB iron ore mine in Kiruna in the far north of Sweden, had some control problems with a big ore crusher. It was decided that an attempt to use adaptive control would be made, using our PDP-15 as the control computer.

The control aspects of the ore crushing process were quite slow, so it would be possible to use a sampling interval of 20–30 seconds. This was slow enough so that the telephone line modems of the day could be used. The crusher already had measurement instrumentation that could send the measured value in the form of a character string. The other direction was handled with a special interface that got one character from the modem, interpreted that character as an eight bit pattern, and converted that pattern to a current that was used as the actuator signal for the crusher. In order to handle transmission errors the actuator “character” was sent over and over again in the conviction that it would be correct most of the time, and an occasional error would not have time to badly influence the control.

The experiment was quite successful, and we boasted that we had created “the longest direct digital control loop in the world” with the control computer being 1800 km away from the plant.

The experiments and their results are described in the PhD thesis by Ulf Borisson (1975)

Remote Control II Towards the middle of the 1970s the heat and ventilation business became interested in more advanced methods to control the indoor climate of buildings. Our department was a natural research partner, and a program was set up. Control computers in those days were of course not transportable, and again some sort of remote control had to be devised.

The equipment we chose was a Hewlett-Packard 2570A Coupler/Controller. It was a fairly complex piece of equipment, with the purpose to be a central control point for other scientific instruments, so that their measurements could be converted to a standard form for transmission over ordinary telephone cables, or over telephone modems if the distances were long. In our case we wanted to take temperature measure-

ments from typically about ten places in a building. The temperature measurements were made with thermistor bridges, read by a digital voltmeter, and then converted with the Coupler/Controller to be transmitted to the PDP-15. There were also a number of relay output channels which we used to create analog outputs that served as actuator signals for the valves and throttles in the heating system of the building.

All in all this was a successful setup. It was small enough to be transported in an ordinary car and it could be set up in a few hours in a building where the climate control experiment were made. Typically the experiments were made during the nights, for two reasons: the building that was experimented on was reasonably empty, and the control computer, i.e. the PDP-15, was easier to claim for extended periods during the nights. Of course no other activity was possible on the computer while the control experiments went on. Since the heating and ventilation system of a building is inherently safe, the experiments didn't have to be manually supervised, so the whole equipment loop could be left to itself during the nights, and the result analyzed the next day.

These experiments and their results are described in the PhD thesis by Lars Jensen (1978).

A difficulty, that seems to have been quite common in those days among researchers using remote control, occurred when some experiments were made in a building in Malmö General Hospital, about 20 km from Lund. For some reason the experiments always stopped after almost exactly two hours. It took quite a long time to confirm that the hospital telephone exchange, routing our modem signals, had a limit of two hours on outgoing telephone calls. This fact was not known to the local exchange staff, or had been carefully forgotten.

Software Development The traditional way to handle software in the early 1970s and before was to build up a library of domain specific Fortran subroutines, together with an extensive "Programmer's Handbook", a binder containing documentation for all these subroutines and also other information about the computer system. Anyone who was using the computer system was given such a binder, with the responsibility to update it, i. e., to insert or replace pages with new or updated information, distributed by the program librarian. The researchers who wanted to solve specific problems were then required to write the problem specific main programs, using the routines in the program library as building blocks.

Obviously this led to a duplication of work, very similar programs being written over and over again, usually by people whose real expertise was in completely different fields than programming.

The remedy for this difficulty was the development of *Interactive Programs*, ready-made software packages where the user could concentrate on the domain specific aspects of the problem solving or the investigation. The programs usually included a certain amount of knowledge about what kind of data sets and what kind of computations were usually required in its specific domain, and the users could control the computations using a language that was closer to their expertise than a traditional programming language. The main architect behind these programs was Johan Wieslander, and the ideas are further described in his PhD thesis, Wieslander (1979), and also in the survey Åström (1983) The work was supported by the Swedish Board for Technical Development.

Our department developed a number of such interactive programs covering various aspects of Automatic Control during the 1970s, and to some extent even later. Examples of the programs are:

SYNPAC, for design of control systems using linear control theory.

IDPAC, for system identification.

MODPAC, for analysis and transformation of linear systems.

SIMNON, for simulation of nonlinear differential equations.

The last program, *SIMNON*, deserves special mentioning, because it became so important for the department research during the years to come. It started out as a Master's Thesis project by Hilding Elmqvist in 1972, and he was then employed as a PhD student and programmer with the task to refine and extend the program.

The main properties of *SIMNON* was that it allowed the breakdown of the system to be simulated into subsystems, which could be nonlinear, and which could be either continuous-time, i.e. described by ordinary differential equations, or discrete-time, i.e. described by difference equations. These subsystems could then be connected to each other in arbitrary configurations, initial conditions and system inputs could be specified, and the compound system could be simulated.

SIMNON was, as mentioned, originally written (in Fortran) for our PDP-15 computer. It was soon also converted to run on the main computer in the university data center, later to our Vax-11/780, to our Sun systems and finally to MS-DOS and Windows. Unlike much university-developed software today it was not open source, but instead we sold it to

industry and to academia, and it actually generated a substantial revenue. In 1989 the program was transferred to SSPA in Gothenburg, who used it for ship simulations, and also continued selling it. As late as in 2006 the author of this *Looking Back* visited Gothenburg Maritime University, and learned that SIMNON was still used as the simulation engine inside the big ship simulators used for educating future ship's officers.

LSI-11 Systems

The PDP-15 was quite successful, and a lot of innovative and useful research was made, but it had one drawback: there was only one workplace. This meant, e.g., that it was not feasible to develop lab exercises in digital control for the undergraduate students, and that had been a desire from the start. In the middle of the 1970s the semiconductor development finally caught up, when Digital Equipment announced the *LSI-11**. It was an entire computer in just four integrated circuits, that fit together with 8MB of semiconductor memory on one 20cm x 26 cm printed circuit board.

The pricing was such that it was possible to get multiple systems, and we started with one “big” and three “small” systems. The main difference was that the big system had a dual diskette unit so that it could have the operating system on diskettes. The small systems could then be connected to the big one with serial lines, so programs could be downloaded and started. All four systems had analog and digital I/O so they

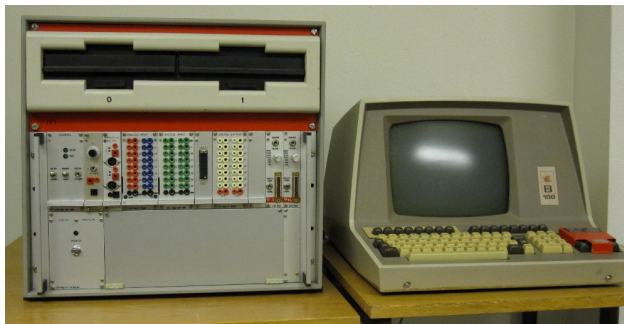

LSI-11 system, with terminal. The top unit is the dual diskette drive, and the CPU is behind the unmarked panel.

could be connected to physical processes, and we could finally do exercises in digital control.

The prices of electronics continued to go down, and in 1977 it was possible to upgrade the small systems so that we had four identical systems, each with a dual diskette drive, and we no longer needed to do early experiments with “diskless clients”.

The operating system for these machines was *RT-11**, a small single-user system that, despite what its name hints, had no real-time properties in the modern sense. It was, however, quite possible to access the hardware directly from user programs, and we could write the controller programs and simple operator interfaces that we needed for the lab exercises. The programming language we used was mostly *Pascal**, with some little assembly snippets for access to the hardware. The general speed of the processors was such that it was quite possible to use a sampling frequency of 50 Hz and still have some time to do operator communication and other computations without time demands.

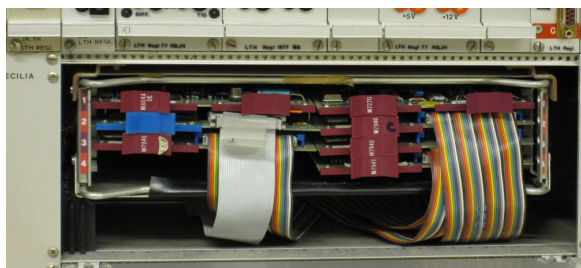

The LSI-11 card cage

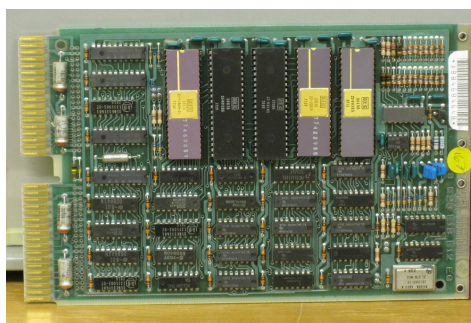

The LSI-11 CPU card

Apart from the lab sessions in digital control, these machines were also used in the early courses in Real-Time Programming, where a significant point was simple System Integration. The students made projects in groups, programming to a specification, and at the end of the course the different programs were tested together to check that they could indeed communicate via the specified protocol.

The VAX-11/780

In the late 1970s it was felt that a new department computer was reasonable. Trough listening to colleagues all over the world, and trough studying various trade magazines, it was fairly clear that the most suitable computer for us was Digital Equipment's brand new machine, the VAX-11, "Virtual Address eXtension" of their earlier PDP-11 family. Even though we knew what we wanted and had the money, as usual we could of course not just phone the supplier and place an order. When we had sent out the requirement specification, a reasonably disguised description of the VAX-11, it turned out that there were two possible contenders for the order. They were the VAX-11/780 from Digital, as expected, and the Prime 750 from Prime Computer, Inc. of Natick, Massachusetts.

They were reasonably similar, both in price and performance, at least on paper, so it was decided that we would test run them, because both companies had installations of the machines offered to us in their respective Stockholm offices. A small evaluation group, Gustaf Olsson and Leif Andersson, went to Stockholm to test first the VAX-11 and then the Prime 750. The test runs didn't give us any reason to change our preferences, and the VAX was ordered. This was a very new system, so there were no courses in Sweden how to run it and maintain it. The closest such courses were in Reading, west of London, and Leif Andersson went there for a two week education.

In September 1980 the machine was delivered and installed. It was really too small already at delivery, having only 0.5 MB of main memory, 2 x 28 MB of disk and eight terminal ports. The people who wanted to use the computer did so from a number of terminals that were put in central places in the two floors on which the department had offices. Those terminals were both purely alphanumerical terminals, 24 lines by 80 characters, and more advanced models that could be programmatically switched between an alphanumerical mode and a graphical mode.



The Vax-11/780. The total width is about 1 m.
(From Wikipedia)

The latter versions enabled diagrams and curves to be drawn by our interactive programs.

Since the VAX turned out to be a commercial success, other suppliers beside Digital Equipment started to make accessories, and the prices fell. As a consequence it became possible to fairly quickly make considerable enhancements to our machine, and within two years it had 2.5 MB of main memory, a disk with 256 MB, 32 terminal lines and a tape station. Later enhancements further increased the main memory to 10 MB and the disk to 750 MB. The increased number of terminal ports meant that it was no longer necessary to have only a few terminals in central places, but instead for the first time each member of staff could, from their own desk, have direct access to a computer.

Among the enhancements at this time was also analog input and output, and some special equipment to interface video cameras so that the first experiments could be made into image processing for control.

Another piece of equipment that would later turn out to be much more important than we understood at the time was the *ethernet** cable that was installed from the M-building to the E-building and further to the university computer center. This was the first pieces in Lund of what was later to become the Internet. The domain name *control.lth.se* became official in 1985.

The programs mostly used on the VAX in the beginning were our own interactive programs IDPAC, MODPAC, SYNPAK and SIMNON, as described in the previous section. They were written in standard Fortran, such that a conversion to other computers was reasonable, and at least the most important ones did indeed become converted fairly quickly.

A significant event occurred in September 1980 when professor Cleve Moler, then of University of New Mexico, took part in an international workshop at the department and presented his new program MATLAB (MATrix LABoratory), which he also installed on our brand new computer. As he testified himself, researchers and engineers in the fields of control engineering and signal processing were quite fond of his program, and the people of our department were no exception. This was of course a few years before MATLAB became a commercial product, but it has remained an important research tool.

The output from the computer, apart from any text or diagrams on the terminals, was first to a couple of *dot-matrix printers** of various capacity. In 1983 we got the possibility to help the university computer center evaluate a brand new product, the laser printer. It was a Canon LBP-10, a fairly big thing, about 100 x 50 x 40 cm, capable of printing about 6 pages per minute. It did not print with carbon powder in a cartridge as today, but with the carbon powder slurried in some kerosene-smelling fluid. There was not much software to drive this printer at the beginning, but we managed to adapt our drivers for the dot-matrix printers to also print on the laser printer.

In about 1984 we became aware of the wonderful new typesetting program TeX, developed by Stanford professor Donald E. Knuth. A version was available for the VAX, and a driver for the Canon printer was also available, so we could soon test it, and haven't looked back since. It is interesting to follow the document preparation method used in the department by for example looking at the annual reports. The 1979 report was prepared on an electric typewriter. In 1980 a dot-matrix printer was used, probably driven by an LSI-11. The 1982 report was again printed on a dot-matrix printer, but of a visibly higher quality, and almost certainly driven by the VAX. In 1984 the Canon laser printer was used for

the first time, and again in 1986. By 1987 laser printers had become so common that we could buy our own, and the annual report was printed on our own printer, using the TeX typesetting software. This has been the method used for document preparation ever since, and still is today.

IBM-PC and Successors

In August 1981 IBM announced their new small computer, the *IBM-PC**. It had an *Intel 8088** CPU, 16 MB of memory, optionally one or two 5½ inch diskettes, a keyboard and a screen, at a price of about \$2,000. A short time later this machine was to be introduced in Sweden, and the marketing department of IBM thought that the use in a high-profile university department was a good advertisement. Our department therefore got as a gift what must have been one of the earliest IBM-PCs in Sweden.

Not much is remembered of how we really used this machine, but in 1984 we had bought two copies of its successor, the IBM-XT. They had the more powerful *Intel 80286** processor and 64MB memory, but still two diskettes and no hard disk. Since the specification for the internal data bus was open, there were many suppliers of various I/O modules, and these machines had analog input and output so that we could experiment with process control. The programming was mainly done in the programming language *Modula-2**, and we had started to develop suitable modules for Real-Time programming.



Karl Johan Aström receives the first IBM PC

A couple of years later we had continued on this road, and in 1987 we had 14 IBM-AT compatibles, each with 640 MB of memory, and 20 MB of disk. The word “compatible” is important here, because as mentioned earlier, the specification was open, and the components were standard Intel processors etc. This meant that other manufacturers than IBM usually delivered these computers at much more favorable prices. The machines had analog I/O for process control, and Modula-2 was still the main programming language, now with a well-developed library for real-time programming.

This family of computers continued to be an important component in our education lab, and they were continually exchanged for newer models as time went on. For a long time the operating system was some version of *MS-DOS**, which really didn't have any real-time properties at all, but where it was easy to access the hardware registers, so that we could have full control over its behavior.

In the late 1990s we intended to change to Microsoft's new operating system *Windows NT**, and we did indeed use it for a short time. However, it turned out to be difficult or impossible to get the sort of real-time properties that we needed, and Windows NT was abandoned.

At the same time, the *Linux** operating system started to mature, and we chose the *Red Hat** distribution to experiment with. This was a much more successful approach, not least because by nature all source code is available. All lab machines got Linux, and soon the staff's desktop machines were also exchanged to PCs running Linux.

The Sun Workstation Network

In the beginning of the 1980s visionary computer engineers in Silicon Valley and in Massachusetts had a dream of the "4M workstation", where the 4M referred to 1 MB of main memory, a screen with 1 Mega-Pixels, and a CPU capable of doing 1 MegaFlops/second, all that at a price lower than 1 MegaPenny, i.e. \$10,000. By the middle of the decade that dream had come true, and in particular two companies were competing fiercely in that particular market segment: Sun Microsystems of Santa Clara, California, and Apollo Computers of Chelmsford, Massachusetts.

Our department had a possibility to test both the Apollo and the Sun, but as the Sun was running a standard Unix operating system and networking with a standard ethernet, and the Apollo had a proprietary sys-

tem, the Domain/OS, and initially was using a proprietary token-ring network, the choice was a fairly simple one in favor of Sun.

Late in 1986 we got our first Sun system, consisting of a Sun 3/180 file server with 380 MB disk and four workstations Sun 3/50. They were connected through the *10Base5** ethernet that we had already installed in order to connect the VAX to the E-building and further to the emerging internet. Luckily we had the foresight to let the cable pass through all our floors, so that all offices could be reached. The workstations had a Motorola 68020 CPU, monochrome screens with a resolution of 1152 x 864 pixels and 4 MB of main memory, but they had no disks. The idea was that all programs and all user data should be communicated on demand from and to the fileserver over the 10 Mbit/s network. This idea may seem impossible today, but it actually worked quite well initially, because there was a balance between the number and speed of the workstations and the capacity of the fileserver and the network.

Just as when we started with the VAX, the four workstations were initially put in a workstation room so that people could go there and start running them. Later on we continued buying Sun Workstations, and people could fairly quickly exchange their terminal to the VAX with a Sun Workstation. The following table, with information mostly taken from earlier Annual Reports, shows the development of our Sun Network. It grew quickly, had a stable development for a number of years, and then collapsed in a surprisingly short time when the Linux PCs could compete with price/performance.

Year	Server	Workstations
1988	4/390, 2.6 GB disk	7 Sun 3/50, 1 Sun 3/110 (first color?)
1990	4/390, 1.6 GB disk	8 SPARCstations (2 color), 12 Sun 3/50
1991	4/390, 2.6 GB disk	18 SPARCstations (4 color), 5 Sun 3/80
1992	4/690, 2.6 GB disk	30 SPARCstation, 18 Sun 3
1994	4/690, 4GB disk	12 SPARCstation color, 25 SPARCstation monochrome
1995	“All members of staff have workstations on their desks”	
1996	Sun Storage Array, see below	Sun Ultra Enterprise 3000, powerful compute server
1997	“About a third of the staff has SparcStation Ultras”	
1998	“For all academic staff the machines are SparcStation Ultras or better”	
2001	People started to get Linux PC	
2002	“Almost all staff and faculty use PCs running Linux”	

Software The program Simnon, that was initially developed on the PDP-15, was converted to the Sun system and continued to play some role, especially in the beginning. It was, however, Matlab, as mentioned in connection with the VAX, that became the most important research tool, and has remained so even today. Another important research field during this time was tools for *Computer Aided Control Engineering*, a development with its roots in the interactive programs of the 1970s. A good survey of this research is found in the *Looking Back* chapter of the annual report for 1998 (Dagnegård and Wittenmark(1999)).

The Raid Debacle A constant worry for system administrators, ever since the invention of computer disks, has been the risk of a disk failure,

and the data loss that would result. Every sensible administrator naturally takes care to backup all important data to magnetic tape or other types of media, but this can usually not be done more than once a day or so, and an eventual retrieval of backup data is quite a slow process. A possible remedy for these problems is to use *raid disks**. There are different versions of these, but the general idea is to have more disks than necessary to hold the data, and organize the writing and reading, through clever algorithms, such that if one disk should fail, it can be replaced with a new one and all data is still available.

Such systems were quite expensive in the middle of the 1990s, but we felt that our research data was important enough to warrant the expense, and we got a Sun Storage Array. It served us well for a number of years, but it was not put to the test until some time in 2000, when a disk failed. That was not a problem, it was exactly what it was made for, so the users of the network didn't notice anything. It was, however, important to replace the failed disk as soon as possible, because the system was designed to handle one failed disk, not more.

We replaced the disk, and gave the command meaning "A replacement disk has been put in the raid. Make it a proper member." It started working, and soon we got strange phone calls from the users saying "All my files are being destroyed!"

It turned out that instead of collecting information from the four disks that were working, and putting it on the new disk, the system had taken data from the new disk, probably all zeros, and spread it over the old and previously healthy disks. We had a service agreement with Sun, but it turned out to be of no real value in this case. They had no explanation for the disaster, and no hardware had been damaged, which was all the service agreement really covered.

Since we had followed good practice and also taken backup on magnetic tape, not much data was really lost, and apart from the system being unavailable for some short period, the users didn't really notice much. It was, however, a severe blow to our confidence in Sun Microsystems, and it speeded up the move to other platforms.

Other Computers

This section describes computer systems that played some role, but not enough to warrant a section of their own.

Microprocessors Towards the middle of the 1970s the electronics development had reached a state where it was possible to put an entire processor on a single chip. It was obvious that such components would be of great interest as parts in a control system, and we did some experiments with them. In particular the programming aspect was interesting, because in the early days tools such as cross assemblers and compilers for high level languages were scarce and expensive. It turned out to be possible to use the assembler of the PDP-15 as a cross assembler (Andersson (1976)), and we also designed a few simple higher level languages with compilation on the PDP-15. An example of such work is the Master's Thesis Hansson, Larsson (1975).

Apple IIe in the Lab When the small analog computers began to feel a little too old as lab equipment, we wanted something that was more suited to lab exercises in process control. The IBM-PC existed, as described before, but it was still far too expensive to be used in multiple lab setups. The solution was the Apple IIe computer, which was announced in 1983. It had a reasonable price and could do simple analog input and output. It was programmed in a dialect of BASIC, and it was possible to draw simple curves on the screen, because each pixel could be addressed directly. The lab exercise programs were made by Karl Johan Åström's son Kalle, then in the ninth grade at school. They were used successfully in lab exercises for a number of years.

Apple Macintosh The first Mac was announced in 1984, and we soon got a few of them. They were used by the department administrators, and they also had the best programs available for drawing figures for our reports and papers. The general use of the Macs ended around 1998 when the central university administration decided that, contrary to their previous assurances, in the future they would only support Microsoft Windows. We have had a few faithful Mac followers all the time, and during the last year the number of Macs has gone up considerably.

Lisp Machine and Graphics Computer During the late 1980s there was a general insecurity in the “computer community” whether one should have general purpose computers, or if it was sensible to have more specialized hardware for different problem classes. We tested this question by having both a *Lisp Machine** and an Iris Workstation from *Silicon Graphics**. The first one had special hardware for running Lisp very efficiently, and the second one had particularly powerful graphical

capabilities. Both these machines gave us important experiences, but it turned out that in an environment with many compatible workstations, two incompatible ones were not useful enough to us, and we only had them for less than two years.

References

- Åström, K. J. (1983): "Computer aided modeling, analysis and design of control systems—A survey." IEEE Control Systems Magazine, 3:2, pp. 4–16.
- Andersson, L. (1976): "Cross assembly and relocation of programs for the Intel microprocessors using a PDP-15 as a host computer." Technical Report ISRN LUTFD2/TFRT- -3098- -SE. Department of Automatic Control, Lund University, Sweden.
- Andersson, P.-O. and T. Olofsson (1971): "Undersökning av Marsiks adaptiva regulator." (Investigation of Marsik's adaptive controller) Master's Thesis ISRN LUTFD2/TFRT- -5102- -SE. Department of Automatic Control, Lund University, Sweden.
- Borisson, U. (1968): "Jämförelse genom analogisimulering mellan manuell styrning och några adaptiva system vid variabel kretsförstärkning." (Comparison, by analog simulation, between manual control and some adaptive systems at variable circuit gain) Master's Thesis ISRN LUTFD2/TFRT- -5027- -SE. Department of Automatic Control, Lund University, Sweden.
- Borisson, U. (1975): *Self-Tuning Regulators—Industrial Application and Multivariable Theory*. PhD thesis TFRT-1010, Department of Automatic Control, Lund University, Sweden.
- Broqvist, S. (1970): "Matematisk modell för sjön Trummen." (Mathematical model of Lake Trummen) Master's Thesis ISRN LUTFD2/TFRT- -5087- -SE. Department of Automatic Control, Lund University, Sweden.
- Dagnegård, E. and B. Wittenmark (1999): "Automatic Control 1998. Activity Report." Technical Report ISRN LUTFD2/TFRT- -4026- -SE. Department of Automatic Control, Lund Institute of Technology, Sweden.

Chapter 7. Looking Back on Computers

- Ekstrand, B. and L.-E. Larsson (1966): “Studium av system för temperaturreglering.” (A study of systems for temperature control) Master’s Thesis ISRN LUTFD2/TFRT- 5006- -SE. Department of Automatic Control, Lund University, Sweden.
- Elmqvist, H. (1972): “SIMNON – Ett interaktivt simuleringsprogram för olinjära system,” (An interactive simulation program for nonlinear systems). Technical Report TFRT-5113. Department of Automatic Control, Lund University, Sweden.
- Elmqvist, H. (1973): “SIMNON—User’s guide.” Technical Report TFRT-3106. Department of Automatic Control, Lund University, Sweden.
- Elmqvist, H. (1978): *A Structured Model Language for Large Continuous Systems*. PhD thesis TFRT-1015, Department of Automatic Control, Lund University, Sweden.
- Gustavsson, I., S. Selander, and J. Wieslander (1973): “Idpac user’s guide.” Technical Report ISRN LUTFD2/TFRT- 7331- -SE. Department of Automatic Control, Lund University, Sweden.
- Hansson, H. and I. Larsson (1975): “Programmeringsarbete på Intel 3000.” (Programming of Intel 3000). Master’s Thesis ISRN LUTFD2/TFRT- 5164- -SE. Department of Automatic Control, Lund University, Sweden.
- Jensen, L. (1978): *Digital Reglering av Klimatprocesser (Digital Control of Climate Processes)*. PhD thesis TFRT-1014, Department of Automatic Control, Lund University, Sweden.
- Wieslander, J. (1979): *Interaction in Computer Aided Analysis and Design of Control Systems*. PhD thesis TFRT-1019, Department of Automatic Control, Lund University, Sweden.

Internet

All references in this section are valid as of May 2010.

Analog Computer: http://en.wikipedia.org/wiki/Analog_computer

DECtape: <http://en.wikipedia.org/wiki/DECtape>

Teletype: <http://en.wikipedia.org/wiki/Teleprinter>

Core Memory: http://en.wikipedia.org/wiki/Magnetic_core_memory

Line Printer: http://en.wikipedia.org/wiki/Line_printer

Polaroid Camera: http://en.wikipedia.org/wiki/Instant_camera

LSI-11: <http://en.wikipedia.org/wiki/PDP-11>

RT-11: <http://en.wikipedia.org/wiki/RT-11>

Ethernet: <http://en.wikipedia.org/wiki/Ethernet>

Dot Matrix Printer: http://en.wikipedia.org/wiki/Dot_matrix_printer

IBM-PC: http://en.wikipedia.org/wiki/IBM_Personal_Computer

Intel 8088: http://en.wikipedia.org/wiki/Intel_8088

Intel 80286: http://en.wikipedia.org/wiki/Intel_80286

MS-DOS: <http://en.wikipedia.org/wiki/MS-DOS>

Windows NT: http://en.wikipedia.org/wiki/Windows_NT

Linux: <http://en.wikipedia.org/wiki/Linux>

Red Hat: http://en.wikipedia.org/wiki/Red_Hat

10Base5: <http://en.wikipedia.org/wiki/10BASE5>

Raid Disk: <http://en.wikipedia.org/wiki/RAID>

Lisp Machine: http://en.wikipedia.org/wiki/Lisp_machine

8. Dissertations

PhD Theses

Two PhD theses were defended this year, by Oskar Nilsson and Martin Ansbjerg Kjaer.

The abstracts are presented below in chronological order. PDF documents of the theses are available at:

www.control.lth.se/publications/

On Modeling and Nonlinear Model Reduction in Automotive Systems



Oskar Nilsson - PhD dissertation, March 6, 2009.

Opponent: Prof. Jacqueline Scherpen, Faculty of Mathematics and Natural Sciences, University of Groningen, Netherlands. Committee: Prof. Per-Olof Gutman, Faculty of Agricultural Engineering, Technion University, Israel; Prof. Bo Egardt, Department of Signals and Systems, Chalmers, Sweden; Sven Erik Mattsson, Dynasim AB, Sweden.

The current control design development process in automotive industry and elsewhere involves many expensive experiments and hand-tuning of control parameters. Model based control design is a promising approach to reduce costs and development time. In this process low complexity models are essential and model reduction methods are very useful tools. This thesis combines the areas of modeling and model reduction with applications in automotive systems. A model reduction case study is performed on an engine air path. The heuristic method commonly used when modeling engine dynamics is compared with a more systematic approach based on the balanced truncation method. The main contribution of this thesis is a method for model reduction of nonlinear systems. The

procedure is focused on reducing the number of states using information obtained by linearization around trajectories. The methodology is closely tied to existing theory on error bounds and good results are shown in form of examples such as a controller used in real-world cars. Also, a model of the exhaust gas oxygen sensor, used for air-fuel ratio control in automotive spark-ignition engines, is developed and successfully validated.

Disturbance Rejection and Control in Web Servers



Martin Ansbjerg Kjaer - PhD dissertation, November 20, 2009.

Opponent: Prof. Tarek Abdelzaher, Department of Computer Science, University of Illinois, USA. Committee: Ass. Prof. Mikael Johansson, EES Automatic Control, KTH, Sweden; Ass. Prof. Markus Fiedler, School of Computing, Blekinge Institute of Technology, Sweden; Bertil Aspernäs, Service Delivery and Provisioning Development, Ericsson AB, Sweden.

An important factor for a user of web sites on the Internet is the duration of time between the request of a web page until an answer has been returned. If this response time is too long, the user is likely to abandon the web site and search for other providers of the service. To avoid this loss of users, it is important for the web site operator to assure that users are treated sufficiently fast. On the other hand, it is also important to minimize the effort to optimize profit. As these objectives often are contradictory, an acceptable target response-time that can be formulated. The resources are allocated in a manner that ensures that long response times do not occur, while, at the same time, using as little resources as possible to not overprovision. The work presented in this doctoral thesis takes a control-theoretic perspective to solve this problem. The resources are considered as the control input, and the response time as the main output. Several disturbances affect the system, such as the arrival rate of requests to the web site. A testbed was designed to allow repeatable experiments with different controller implementations. A server was instrumented with sensors and actuators to handle requests from 12 client computers with capability for changing work loads. On the theoretical side, a model of a web server is presented in this thesis. It explicitly mod-

els a specific sensor implementation where buffering occurs in the computer prior to the sensor. As a result, the measurement of the arrival rate becomes state dependent under high load. This property turns out to have some undesirable effects on the controlled system. The model was capable of predicting the behavior of the testbed quite well. Based on the presented model, analysis shows that feed-forward controllers suggested in the literature can lead to instability under certain circumstances at high load. This has not been reported earlier, but is in this doctoral thesis demonstrated by both simulations and experiments. The analysis explains why and when the instability arises. In the attempt to predict future response-times this thesis also presents a feedback based prediction scheme. Comparisons between earlier predictions to the real response-times are used to correct a model based response time prediction. The prediction scheme is applied to a controller to compensate for disturbances before the effect propagates to the response time. The method improves the transient response in the case of sudden changes in the arrival rate of requests. This doctoral thesis also presents work on a control solution for reserving CPU capacity for a given process or a given group of processes on a computer system. The method uses only existing operating-system infrastructure, and achieves the desired CPU capacity in a soft real-time manner.

Licentiate Theses

Three licentiate theses were also defended during 2009, by Olof Garpinger, Anders Widd and Aivar Sootla.

The abstracts are presented below in chronological order. PDF documents of the theses are available at:

<http://www.control.lth.se/publications/>

Design of Robust PID Controllers with Constrained Control Signal Activity



Olof Garpinger – Licentiate dissertation, March 27, 2009.

Opponent: Alf Isaksson, ABB, Västerås, Sweden.

This thesis presents a new method for design of PI and PID controllers with the level of control signal

activity taken into consideration. The main reason why the D-part is often disabled in industrial control loops is because it leads to control signal sensitivity of measurement noise. A frequently varying control signal with too high amplitude will very likely lead to actuator wear and tear. For this reason it is extremely important for any PID design method to take this into account. The proposed controllers are derived using a newly developed design software that solves an IAE minimization problem with respect to H_∞ robustness constraints on the sensitivity- and complementary sensitivity function. The software is shown to be fast, easy to use and robust in giving well-performing controllers. By extracting measurement noise from the process value of a real plant, one can estimate its effect on the control signal variance. The time constant of the low-pass filter, through which measurements are fed, is varied to design controllers with constrained control signal activity. By comparing control signal variance and IAE, the user is also able to weigh actuator wear to estimated performance. The proposed PID design method has shown to give very promising results both on simulated examples and real plants such as a recirculation flow process. Optimal Youla parametrized controllers are used both as a quality check of the designed PI and PID controllers and as a tool for determining when these are valid choices compared to more advanced controllers.

Predictive Control of HCCI Engines using Physical Models



Anders Widd – Licentiate dissertation, May 25, 2009.
Opponent: Ass. Prof. Lars Eriksson, Department of Electrical Engineering, Linköping University Sweden.

Homogeneous Charge Compression Ignition (HCCI) is a promising internal combustion engine concept. It holds promise of combining low emission levels with high efficiency. However, as ignition timing in HCCI operation lacks direct actuation and is highly sensitive to operating conditions and disturbances, robust closed-loop control is necessary. To facilitate control design and allow for porting of both models and the resulting controllers between different engines, physics-based mathematical models of HCCI are of interest. This thesis presents work on a physical model of HCCI including cylinder wall

temperature and evaluates predictive controllers based on linearizations of the model. The model was derived using first principles modeling and is given on a cycle-to-cycle basis. Measurement data including cylinder wall temperature measurements was used for calibration and validation of the model. A predictive controller for combined control of work output and combustion phasing was designed and evaluated in simulation. The resulting controller was validated on a real engine. The last part of the work was an experimental evaluation of predictive combustion phasing control. The control performance was evaluated in terms of response time and steady-state output variance.

Model Reduction Using Semidefinite Programming



Aivar Sootla – Licentiate dissertation, November 27, 2009.

Opponent: Professor Anders Hansson, Department of Electrical Engineering, Linköping University, Sweden.

In this thesis model reduction methods for linear time invariant systems are investigated. The reduced models are computed using semidefinite programming. Two ways of imposing the stability constraint are considered. However, both approaches add a positivity constraint to the program. The input to the algorithms is a number of frequency response samples of the original model. This makes the computational complexity relatively low for large-scale models. Extra properties on a reduced model can also be enforced, as long as the properties can be expressed as convex conditions. Semidefinite programs are solved using the interior point methods which are well developed, making the implementation simpler. A number of extensions to the proposed methods were studied, for example, passive model reduction, frequency-weighted model reduction. An interesting extension is reduction of parameterized linear time invariant models, i.e. models with state-space matrices dependent on parameters. It is assumed, that parameters do not depend on state variables nor time. This extension is valuable in modeling, when a set of parameters has to be chosen to fit the required specifications. A good illustration of such a problem is modeling of a spiral radio frequency inductor. The physical model depends nonlinearly

on two parameters: wire width and wire separation. To chose optimally both parameters a low-order model is usually created. The inductor modeling is considered as a case study in this thesis.

9. Honors and Awards

Karl Johan Åström

Received the Ruby Author from IET Inspec for being a researcher whose work has appeared in the Inspec Database both in the inaugural year 1969 and again in 2008. Just over 100 researchers have been given this award.

Isolde Dressler, Rolf Johansson and Anders Robertsson

Received the Best Paper Award from the 13th IFAC Symposium on Information Control Problems in Manufacturing (INCOM'09) for their article “Reconfigurable Parallel Kinematic Manipulator for Flexible Manufacturing” written together with M. Haage, K. Nilsson and T. Brogårdh.

Stefan Skoog

Received the Swedish Embedded Award for his project “Small-scale high-end motor control”, partly developed within a project course in Industrial Electrical Engineering and Automation at Lund University.

10. Personnel and Visitors



Personnel

During 2009 the following persons have been employed at the department. The list shows the status of December 2009 if nothing else is mentioned.

Professors

Karl-Erik Årzén
Karl Johan Åström

Chapter 10. Personnel and Visitors

Bo Bernhardsson (part time)
Per Hagander
Tore Hägglund
Rolf Johansson
Anders Rantzer
Björn Wittenmark

Associate Professors

Anton Cervin
Andrey Gulchak (part time)
Charlotta Johnsson
Anders Robertsson

Assistant Professor

Johan Åkesson

Research Engineers

Leif Andersson
Anders Blomdell
Rolf Braun
Anders Nilsson (from October)

Post Doctors

Ahmed El-Shaer (from April)
Kin Cheong Sou
Vladimeros Vladimerou (from March)

PhD Students

Martin A. Kjaer (until November)
Payam Amani
Karl Berntorp (from February)
Marzia Cescon
Isolde Dressler
Olof Garpinger (until December)
Pontus Giselsson

Erik Johannesson
Maria Karlsson
Per-Ola Larsson
Mikael Lindberg
Magnus Linderoth
Anna Lindholm (from February)
Daria Madjidian
Karl Mårtensson
Oskar Nilsson (until January)
Toivo Perby Henningsson
Philip Reuterswård
Vanessa Romero Segovia
Alina Rubanova (from October)
Kristian Soltesz
Aivar Sootla
Meike Stemmann (from November)
Fredrik Ståhl (part-time)
Anders Widd

Project Assistants

Martin Hast (from June)
Jesper Mattsson (from November)
Alina Rubanova (May-September)
Stefan Skoog (from September)

Administrators

Britt-Marie Mårtensson
Ingrid Nilsson (from March)
Eva Schildt
Eva Westin

Visitors

Visiting Scientists

The following researchers have stayed with the department for some shorter or longer period of time.

Chapter 10. Personnel and Visitors

Lachlan Blackhall, University of Canberra, Australia (August-September)
Filippo Donida, Politecnico di Milano, Italy (June-July)
Sebastian Dormido, University of Madrid, Spain (September)
Felix Farias, Brasilia (Erasmus Mundus - Euro-Brazilian Windows (March-December)
Juan Garrido, University of Cordoba, Spain (August-November)
Alexandra Grancharova, Bulgarian Academy of Sciences, Bulgaria (August-November)
José Luis Guzmán, University of Almeria, Spain (September)
Mustafa Khammash, University of California Santa Barbara, USA (October)
José Maestre, University of Seville, Spain (from August)
John Morrell, Yale University, USA (June)
Anton Shiriaev, Umeå University (April)
Yifan Wu, Scuola Superiore Sant'Ana, Pisa, Italy (March-July)
Ling Zhong, Shanghai Jia Tong University, China (from September)
Ranko Zotovic Stanisic, Polytechnical University of Valencia, Spain (September-December)

Visiting Students

The following foreign students from the ERASMUS program have stayed with us at the department working on their master's theses.

Timothée Basson, France (until May)
Christophe Haas, Germany (from August)
Lorenz Halt, Germany (until July)
Julia Herget, Germany (until May)
Anne-Kathrin Hess, Germany (until August)
Julien Lescot, France (until May)
Roberto Parrotto, Italy (from October)
Johannes Schiffer, Germany (until June)
Meike Stemann, Germany (until October)

11. Staff Activities

This is a short description of the staff (listed in alphabetical order) and their activities during the year. Publications and lectures are listed in separate sections (chapter 11 and 13 respectively).

Åkesson, Johan

Assistant Professor, PhD (2007); joined the department in 2001. Johan's main research interest is in the field of languages and tools for dynamic optimization of large scale systems, including language design, compiler design and implementation, numerical algorithms, and industrial applications. He is currently leading the JModelica.org project aimed at developing a Modelica-based open source platform for optimization of dynamic systems. Within the PIC-LU research project, he is leading the subproject dealing with grade change optimization in cooperation with the plastics manufacturer Borealis. During 2009, he co-supervised three master's thesis projects: "Optimal Control and Path Following for Industrial Robots" (Martin Hast), "Multiple Shooting Optimization using the JModelica.org Toolchain" (Jens Rantil, in collaboration with the Department of Mathematics), and "The JModelica IDE: Developing and IDE by Reusing a JastAdd Compiler" (Jesper Mattsson, in collaboration with the Department of Computer Science). Johan is also associated with Modelon AB, where he works part time.

Andersson, Leif

MSc, Research Engineer since 1970. Leif started at the department with a responsibility for the teaching laboratory. He designed some lab equipment, notably an analog computer. In 1976 he started in earnest with digital computers, and has been responsible for the department computing facilities since then. The main computer systems have been RT11, VAX/VMS, Sun Solaris, Linux and lately MacOSX. He has also been forced to handle Microsoft Windows. His professional activities, apart from computer system maintenance, have ranged from computer typesetting (TeX and LaTeX) via Real Time Programming to using Java as a tool for writing educational software.

Årzén, Karl-Erik

Professor (2000), PhD (1987): Joined the department in 1981. His research interests are real-time and embedded control, real-time systems, programming languages for control, Petri nets and Grafset, and monitoring and diagnosis. Leader of the Design for Adaptivity activity in the EU/IST FP7 network of excellence ArtistDesign. During the year he has primarily been involved in the EU/IST FP7 STREP project ACTORS (Adaptivity and Control of Resources in Embedded Systems). He has been responsible for and taught the undergraduate course Real-Time Systems. He is partly or fully involved in the supervision of four PhD students.

Åström, Karl Johan

Professor in Automatic Control since 1965, founder of the department, emeritus from 2000. This year he has worked on event based control, friction modeling and control of microsystems. He gave a new graduate course on Control of Microsystems at UCSB. In May he visited Prof Gerd Jaeger's group at the Institute of Process Measurement and Sensor Technology in Ilmenau to work on friction modeling. He participated in the ARTIST2 summer school. He has given many invited lectures to academic and industrial audiences during the year.

Bernhardsson, Bo

PhD 1992, Professor 1999, on leave for industry work since 2001. In 2009 he worked 20% at the Department and 80% at Ericsson Mobile Platforms in Lund. Bo's research interests are in linear systems, practical applications of control theory, and the connection between communication and control theory. He has been co-directing the thesis of Erik Johannesson. He has been responsible for and taught the PhD courses Linear Systems and Linear Systems II.

Berntorp, Karl

MSc in Engineering Physics, graduate student since January 2009. Karl is part of the ENabling GROwing Software Systems (ENGRASS) project, currently focusing on control of mobile manipulators. During the year he has been involved in teaching the courses Basic Course in Automatic Control, Project Course in Automatic Control, and Real-Time Systems. He has also been attending PhD courses.

Blomdell, Anders

Research Engineer at the department since 1988. Heavily involved in almost all aspects of Robotics Research at the department, also responsible for the department network and lab computers for teaching and research. The first half of 2009 was in a large part dedicated to finishing touches of the SMErobot project. The second half focus was shifted to the run-time architecture in the Actors project, but also managed to get a preliminary version of open Powerlink and B&R field-bus modules interfaced to the software used for our teaching activities in China.

Braun, Rolf

Research Engineer at the department since 1969. Designs and builds equipment for education and research, and handles hardware maintenance of computers and equipment. He also plans and supervises maintenance and rebuilding of offices and labs.

Cervin, Anton

Associate professor, PhD (2003); joined the department in 1998. Anton's research interests include real-time systems, event-based and networked control, and computer tools for analysis and simulation of controller timing. During 2009, he has worked in the research project "Periodic and event-based control over networks", together with PhD student Toivo Henningsson. He is also involved in the EU/FP7 projects ArtistDesign and ACTORS. During the year, he has been responsible for the basic-level courses Systems Engineering and Automatic Control, Basic Course. He has also given short courses on control and real-time systems at Linköping University, Scuola Superiore Sant'Anna in Pisa, and Universidad Politécnica de Valencia. He is Director of Studies for the China Profile at LTH and spent a total of eight weeks at Zhejiang University in Hangzhou, China.

Cescon, Marzia

BSc, MSc, graduate student since July 2008. Main research interests involve subspace-based identification techniques with application to biomedical systems. Currently working on the DIAdvisor project within the European FP7-ICT program, pursuing research on prediction and predictive control of blood glucose concentration in diabetic subjects. Her teaching activities during the spring were related to the System Identification Course, and during the fall to the Basic Course in Automatic Control and the Predictive Control Course.

Dressler, Isolde

Msc, graduate student since September 2004. Isolde is interested in modeling, calibration and control of parallel kinematic robots and worked within the SMERobot project. She was a teaching assistant in the System Identification course.

El-Shaer, Ahmed

Ahmed has been a post-doctoral research at the LCCC since April 2009. He has joined the AEOLUS project focusing on the distributed control of wind farms. Ahmed is currently working on a control design framework for robust distributed optimization of the wind farm power production performance. He has also been working on optimal synthesis of robust controllers satisfying multi-objective performance criteria.

Garpinger, Olof

Graduate student since August 2005. Olof has developed a new Matlab based software for design of IAE optimal PID controllers with robustness constraints. The software has been used to derive PI and PID controllers for real plants, with the hope to make the D-part more accepted in industry. The idea is to let the user set a limit on the maximum allowed control signal variance due to measurement noise. Olof has had several collaborations with the the industry to confirm the usefulness of the theory. During 2009, Olof has published his licentiate thesis and been a teaching assistant in the Basic Control course.

Giselsson, Pontus

MSc, graduate student since November 2006. So far Pontus has spent most of his time on courses. He has also been a teaching assistant in two basic courses, Automatic Control and Systems Engineering, and in one advance course, Nonlinear Control and Servo Systems. Pontus has also created a new laboratory exercise that is used in the course Nonlinear Control and Servo Systems.

Hagander, Per

Professor, PhD (1973). Per has been with the department since 1968 and works with linear system theory and with applications in biotechnology and medicine. During 2009 he taught the basic course together with the course Control Theory. On November 30, 2009, Per Hagander retired

from his position as professor. He continues part time as Senior professor.

Henningsson, Toivo Perby

Lic. Tech., graduate student since August 2005. His research interests are in event based, distributed and embedded control and estimation. Toivo was on paternal leave during January through August 2009. During the rest of the year, he has been working on event based control using approximate value functions.

Hägglund, Tore

Professor, PhD (1984). Has been at the department since 1978 except for four years when he worked for ABB. He is responsible for three of the basic courses in Automatic Control in the engineering program. His main research interests include process control, PID control, adaptive control, control loop monitoring and diagnosis. Main research activities during the year have been design of PID controllers, decentralized control structures, and valve stiction diagnosis. Tore Hägglund is also deputy centre director of *Centre for Research and Competence Development for the Process Industry*, PIC-LU.

Johansson, Rolf

Professor, MD, PhD. Active at the department since 1979. Rolf Johansson's research interests are in system identification, robotics and nonlinear systems and automotive control. He is node leader for the research projects DIAdvisor, SMErobot, HYCON, SSF ProViking ProFlexa, Vinova PFF Diesel HCCI, ROSETTA. He is coordinating director for Robotics Laboratory with cooperation partners from Dept Computer Science, Dept Mechanical Engineering, Dept. Mathematics and industrial partners. He has industrial cooperation with ABB Robotics, Volvo Powertrain. He is responsible for the two courses FRT041 System Identification and FRT050 Adaptive Control. Together with Dr. Måns Magnusson he leads research at the Vestibular Laboratory, Dept. Otorhinolaryngology, Lund University Hospital.

Johannesson, Erik

M.Sc. in Engineering Mathematics. Ph.D. student since May 2006. He is currently working in the research project "Control with Communication Constraints". Previously, he has done some work in event-based control. During the spring, Erik was a teaching assistant for the basic course as

well as in the Project course. During the fall, Erik was a teaching assistant for the basic course given at Zhejiang University, Hangzhou, China.

Johnsson, Charlotta

Research Associate, PhD (1999). Charlotta has been at the department since 1993 except for 4 years (2000-2004) when she worked for Siemens. Charlotta's main research interest is in Production Control, Batch Control Systems, Manufacturing Operations System. Charlotta is one of the principal investigators of the LCCC research program. She is also part of the management team for the research center PIC-LU in which she is leading one of the sub-projects. Charlotta is serving as the Program Leader for Technology Management, a joint programme run by Lund Institute of Technology and the School of Economics and Management at Lund University. Charlotta is also working 10% for Genombrottet, LTH's center for Pedagogical Development. Charlotta is co-responsible for the Pedagogical magazine *Lärande i LTH*. During the year, Charlotta has been involved in a variety of courses stretching from technical courses for master students to pedagogical courses for teachers in higher education. Charlotta acted as supervisor and/or examiner for nine (6) master theses. The projects were done in cooperation with industry.

Karlsson, Maria

LicSc, graduate student since August 2005. She is working with Professor Rolf Johansson in the project Diesel-HCCI in Multi-cylinder Engines in cooperation with Volvo Powertrain and the division of combustion engines at Lund University. During 2009 she did experimental work on MIMO control of diesel engines using MPC to minimize emissions of NO_x and soot. From October to December she was on maternity leave with her daughter Alice.

Kjær, Martin Ansbjerg

MSc, LicSc, graduate student since August 2003. He is working in the field of active control of web servers together with Anders Robertsson. During the last year he has been focusing on experimental work. His teaching activities were related to being a teaching assistant in the advanced topic of Nonlinear Control of Servo Systems.

Larsson, Per-Ola

MScEE (2005), graduate student since January 2008. His research interests are within process control. Per-Ola is involved in a project to

gether with his supervisor Prof. Tore Hägglund concerning tuning methods for a dead-time compensating PID controller. Also, tuning of measurement filter giving the opportunity to set control signal variations due to measurement noise is a part of the project. During the year Ass. Prof. Johan Åkesson became Per-Ola's assistant supervisor as the PIC-LU project started. Together with Borealis in the project, optimal grade changes for a chain of polyethylene reactors will be computed using Modelica and the framework of JModelica.org. Per-Ola has been involved in teaching two of the basic courses and also Multivariable control, and Predictive control.

Lindberg, Mikael

MSc, graduate student since July 2007. Main research interests lie in resource management and control for embedded systems using feedback scheduling and reservation based scheduling techniques. Currently participating in the ACTORS-project, a EU sponsored project run by Ericsson Mobile Platform (EMP), and in the “Feedback Based Resource Management and Code Generation for Soft Real-Time Systems”, a VINNOVA sponsored project also in co-operation with EMP. During the fall, Mikael was a teaching assistant in the course Realtime Systems.

Linderoth, Magnus

MSc, graduate student since September 2008. He is working in the Rosetta project, which aims to develop robots that are easy to program, adaptive, can share information and work safely next to humans. Magnus focuses on force control, redundancy resolution and vision feedback. During 2009 he has been involved in teaching of the basic course in Automatic Control, the advanced course in Mathematical Modeling and Real-Time Systems.

Lindholm, Anna

MSc in Engineering Physics. PhD student since February 2009. Anna's main research interests are within process control. Currently she's working on developing methods for handling plant-wide disturbances, a research project within the Process industrial center center, PicLu. She is also interested in buffer management, which was the topic of her Master's thesis. During 2009 she spent most of her time on courses and being a teaching assistant in the basic Automatic Control Course.

Madjidian, Daria

Daria has a M.Sc in Electrical Engineering and started as a Ph.D student at the department of Automatic control in August, 2008. He is involved in the EU-funded research project Aeolus with Anders Rantzer. The objective of AEOLUS is to address the effect of aerodynamic coupling in wind farms. During fall of 2009 he tutored the basic course in Automatic Control.

Mårtensson, Britt-Marie

Secretary at the department since 1974. She is responsible for the department library, orders books and handles the mail and office supplies. Assistant Webmaster. She also handles the contact with printing offices for dissertations and other publications. Britt-Marie is also the department's service person.

Mårtensson, Karl

MSc, graduate student since December 2006. Karl's research concerns Distributed Control. In this area, he is working with Professor Anders Rantzer. He is currently part of the CHAT project. He has also worked with Model Predictive Control, especially dealing with computational delays. Karl has been involved in teaching the basic course in Automatic Control, as well as in some more advanced courses, e.g. Control Theory.

Nilsson, Ingrid

Administrator at the department since March 2009. Ingrid is mainly responsible for the financial transactions at the department such as book-keeping and reporting to our sponsors.

Rantzer, Anders

Professor of Automatic Control since 1999 and head of department. He has broad interests in modeling, analysis and synthesis of control systems, with particular attention to robustness, optimization and distributed control. Anders Rantzer is the main supervisor for several PhD students. During 2009, he taught the courses "FRTN10 Multivariable Control", "FRT095 Mathematical Modelling". A short PhD course on Distributed Control was given at Linköping University in September. He also served on several international scientific committees.

Reuterswård, Philip

Civ.ing., Dipl.-Math. techn., graduate student since January 2008. During 2009 he continued to bring value to the market in the EUROSYSLIB project. He started to collaborate with the Laird Research Group at Texas A&M University, working with parallel solution of large-scale dynamic optimization problems. Moreover he was involved with teaching various courses at the department.

Robertsson, Anders

Associate professor (2007), "Docent" (2005), Research Associate (May 2003), PhD (1999). Excellent Teaching Practitioner (ETP) in 2007. His main interest is in nonlinear control and robotics. Currently he is working on parallel kinematic robots, sensor-data integration and force control of industrial robots in collaboration with ABB Robotics. The research has been conducted with the LUCAS project, the Robotics Lab, The Linnaeus Centre LCCC and the EU funded projects SMERobot (FP-6) and ROSETTA (FP-7). He has also been doing research on admission control in network nodes and control of server systems in cooperation with the Department of Electrical and Information Technology, LTH. He has lectured in the basic course on Automatic Control, in Multivariable Control and in the course on Nonlinear Control and Servo Systems, given a graduate course an advanced robotics (Valencia, Spain) and acted as advisor/co-advisor for 6 PhD students and several Master's Thesis projects.

Romero Segovia, Vanessa

Born in Peru, she is a MSc graduate student since August 2008. Vanessa is interested in real-time systems and embedded control and is currently working for the ACTORS project. During the autumn she was a teaching assistant in the Real-Time Systems course.

Schildt, Eva

Secretary at the department since 1970. Eva is mainly responsible for the financial transactions of the department such as bookkeeping and reporting to our sponsors. She handles the personnel administration and takes care of the administration concerning visitors at the department.

Soltesz, Kristian

MSc, graduate student since October 2008. Kristian has spent the first year of his PhD looking into system identification for PID tuning. This

Chapter 11. Staff Activities

ongoing project is carried out within the Process Industrial Centre at Lund University (PICLU). Recently he has also been working on state space partitioning strategies for explicit model predictive control. During 2009 Kristian has been involved in teaching the Predictive Control course and developing material for the Basic, Predictive, Market Driven and Multi-Variable Control courses.

Sootla, Aivar

MSc, graduate student since September 2006. Aivar's main research interests are model reduction, simplification and validation. He has also been a teaching assistant in the Multivariable Control course and in the Automatic Control basic course.

Sou, Kin Cheong

PhD (2008). Postdoc since Oct 2008. His research interests include optimization with applications to engineering problems with main focus on system theory and model reduction for dynamical systems. In 2009, he was responsible for holding a self-study version of the PhD course "Convex Optimization with Applications". In addition, he worked on controller reduction and related matrix approximation problems.

Ståhl, Fredrik

M.Sc.(2003), 50 % graduate student since 2008. Fredrik is involved in the DIAdvisor project, where his research has focused on modeling, identification and prediction of blood glucose dynamics. Together with Prof. Rolf Johansson he has written the journal paper "Diabetes Mellitus modeling and short-term prediction based on blood glucose measurements" published in *Mathematical Biosciences* 217 2009 (pp. 101-117). During the year the following conference contributions were co-authored together with Marzia Cescon, Prof. Rolf Johanson, and various clinical partners: In February 25-28 the poster "Short-Term Diabetes Blood Glucose Prediction Based On Blood Glucose Measurements" was presented at the 2:nd International Conference on Advanced Technologies and Treatments for Diabetes in Athens. The paper "Subspace-Based Model Identification of Diabetic Blood Glucose Dynamics" appeared at the 15th IFAC Symposium on System Identification, St. Malo, France, July 6-8. The conference contribution "Infinite Horizon Prediction of Post-Prandial Glucose Excursion" was presented at the Diabetes Technology Meeting Nov. 7-9 in San Francisco, U.S.

Vladimerou, Vladimeros

PhD 2009. Postdoc since March 2009. Main interest in verification and synthesis with performance guarantees in hybrid systems and games. In 2009 he was the instructor for a new course "Introduction to Hybrid Systems and Verification" and the supervisor for three on-going MSc theses. He has also been involved in various activities regarding the CHAT project, with concentration in distributed task allocation.

Westin, Eva

PhD in French linguistics. Administrator at the department since November 2008. She has the overall responsibility for the registration of students and PhD students as well as for their exam results. She updates parts of the department's web site. Eva is also working with administration of the LCCC Linnaeus project and visitors at the department. Together with Rolf Johansson she is responsible for the Activity Report 2009. Eva is the co-supervisor of two PhD theses in French linguistics at the Center of Languages and Literature at Lund University.

Widd, Anders

LicSc, graduate student since December 2006. He is working with Professor Rolf Johansson on the project "KCFP, Closed-Loop Combustion Control", which is a cooperation with the Division of Combustion Engines. He has also participated in the project "Diesel-HCCI in a Mutlicylinder Engine". During 2009 he completed his licentiate thesis, which was presented in May. During the fall, he was a guest researcher at Stanford University, Dept. Mechanical Engineering, California, where he worked with Prof. J. Christian Gerdes on hybrid control of HCCI engines. The visit was financed by the VinnPro research academy in combustion engines.

Wittenmark, Björn

He joined the department in 1966 and took his PhD in 1973. He became full professor at the department 1989. His main research interests are adaptive control, sampled-data systems, and process control. He is currently working within projects in the area of process design and control and control of communication networks. He is now emeritus professor at the department.

External Assignments

Opponent and Member of Examination Committee

Årzén, Karl-Erik

Member of the PhD thesis committee for Lars Alminde, Feb 5, Automation & Control, Dept. Electronic Systems, Aalborg University. Member of the PhD thesis committee for Jacob Deleuran Grunnet, Oct 5, Automation & Control, Dept. Electronic Systems, Aalborg University. Deputy member of the PhD thesis committee for Carl Wilhelmsson, Dec 4, Department of Energy Sciences, Lund University. External reviewer of the PhD thesis by Filippo Donida, Dipartimento di Elettronica e Informazione, Politecnico di Milano.

Bernhardsson, Bo

Member of the Examination Committee for the PhD thesis “Differential Equations with Constraints” by Oliver Verdier, Dept. Mathematics, Lund, June 12.

Hägglund, Tore

Member of the Examination Committee for the PhD thesis by Johan Wahlström, June 12 at Linköping University, Linköping, Sweden. Faculty opponent on the PhD thesis by Vesa Hölttä, October 9 at Helsinki University of Technology, Helsinki, Finland.

Rantzer, Anders

Member of PhD thesis committee for Björn Johansson Jan 30, at Royal Institute of Technology (KTH). Member of PhD thesis committee for Johan Öinert, Aug 17 at Centre for Mathematical Sciences, Lund University.

Robertsson, Anders

External Assessment of PhD thesis “Kinematic and Elasto-Dynamic Design Optimisation of a Class of Parallel Kinematic Machines” by Ilya Tyapin, March 24, The University of Queensland, Brisbane, Australia.

Member of PhD-thesis committee Christian Smith “Input Estimation for Teleoperation”, Royal Institute of Technology, Dec 11, Stockholm.

Board Member

Årzén, Karl-Erik

Member of the Research Board 1, Lund University. Member of the Executive Management Board of the ArtistDesign Network of Excellence. Member of the Strategic Management Board of the ArtistDesign Network of Excellence.

Cervin, Anton

Board Member of SNART (the Swedish National Real-Time Association). Deputy member of Academic Appointments, Board n°2 at LTH.

Hägglund, Tore

Expert member in legal proceedings for patent at Svea Court of Appeal, 2007–2009.

Johansson, Rolf

Board Member of DIAdvisor Executive Board. Board Member of ROSETTA Project Management Board, 2009-2013. Board Member of ROSETTA Project Scientific Board, 2009-2013. Chairman of ROSETTA Project Scientific Board 2009.

Johnsson, Charlotta

Board member of WBF (the Forum for Automation and Manufacturing Professionals). Charlotta serves as the Director of European Operations. Board member in Technology Management Center (TMC) at Lund University. Member in UN3 (utbildningsnämnd 3) at LTH.

Rantzer, Anders

Member of the steering committee for the International Symposium on Mathematical Theory of Networks and Systems. Member of the Advisory Board for Lecture Notes in Control and Information Sciences at Springer Verlag Heidelberg. Member of the IEEE Control System Society Technical Committee on Nonlinear Systems and Control. Member of the IFAC Technical Committee on Nonlinear Systems Member of the Swedish IFAC Committee. Expert evaluator for VINNOVA.

Wittenmark, Björn

Chairman Lund Laser Center. Board member of LUCAS and EASE. Board member Gyllenstiernska Krapperupsstiftelsen. Member of the Technical Committee for IFAC Adaptive Control and Learning. Reviewer for research evaluations for the Australian Research Council, Italian Ministry for Education University and Research (MIUR) and Norwegian Research Council.

Book and Journal Editor

Hägglund, Tore

Editor for Control Engineering Practice.

Johansson, Rolf

Associate Editor, Int. J. Adaptive Control and Signal Processing. Associate Editor, Chinese Journal of Scientific Instrument (China Instrument and Control Society).

Wittenmark, Björn

Journal of Forecasting. IEEE Proceedings Control Theory & Applications.

Advisory Committees and Working Groups

Hagander, Per

Member of IFAC Technical Committee BIOMED. Member of IFAC Technical Committee Biotechnological Processes. Member of ESBES--Working group M³C.

Johansson, Rolf

Science Foundation Ireland (SFI), Research Frontiers Programme (RFP), March 22-24, 2009. Reviewer Seventh EU Framework Programme (FP7), Nanosciences, Nanotechnologies, Materials and New Production Technologies (NMP-2009), September 2009. Reviewer Seventh EU Framework Programme (FP7), Nanosciences, Nanotechnologies, Materials and New Production Technologies (NMP-2010), FP7-2010-NMP-ICT-

FoF Factory of the Future, December 2009. Board Member of DIA Advisor Scientific Board. Member of IEEE EMBS Technical Committee (TC) for Biomedical Robotics. Member of Joint EMBS/RAS Advisory Committee on Biorobotics.

Johnsson, Charlotta

Voting member in the standardisation committee ISA 95. Information member in the standardisation committees ISA 88 and ISA 99. Member in SEK and serves as the Swedish expert in the international IEC and ISO working group JWG5. Working 10% for Genombrottet, LTH's center for Pedagogical Development. Serves as the IFAC Liaison with IEC 65A.

Robertsson, Anders

Member of evaluation board for excellent teaching practitioners (ETP), LTH, Lund University.

Wittenmark, Björn

Reviewer for research evaluations for the Australian Research Council, Italian Ministry for Education University and Research (MIUR) and Norwegian Research Council.

Member of International Program Committee (IPC)

Årzén, Karl-Erik

Co-chair of the Fourth International Workshop on Feedback Control Implementation and Design in Computing Systems and Networks (FeBID), San Francisco, CA, USA, April 2009. Member of the IPC for the 21th European Conference on Real-Time Systems (ECRTS), Dublin, Ireland, July 2009. Member of the IPC for the IEEE Conference on Control Applications (CCA), St Petersburg, July 2009. Member of the IPC for the Modelica 2009 Conference, Como, Italy, September 2009. Co-chair of the 2nd Workshop on Adaptive and Reconfigurable Embedded Systems (APRES), Grenoble, Oct 2009. Member of the IPC for the 30th IEEE Real-Time Systems Symposium (RTSS), Washington, DC, USA, Dec 2009

Cervin, Anton

Member of the Program Committee of the Workshop on Adaptive and Reconfigurable Embedded Systems (APRES'09).

Hagander, Per

Member of IPC for the 11th Symposium on Computer Applications in Biotechnology (CAB 2010) in Leuven (Belgium). Member of IPC for the 7th IFAC Symposium on Modelling and Control in Biomedical Systems.

Hägglund, Tore

International Symposium on Advanced Control of Industrial Processes, Jasper, Canada, 2009 IEEE International Conference on Control Applications, Saint Petersburg, Russia, IFAC Symposium on Advances in Control Education, ACE 2009, Kumamoto, Japan, and Control Systems 2010, Stockholm, Sweden.

Johansson, Rolf

IPC Member of the 13th IFAC Symposium on Information Control Problems in Manufacturing, V. A. Trapeznikov Institute of Control Sciences, Russian Academy of Sciences, Moscow, Russia, June 3-5, 2009. IPC Member of the 9th International IFAC Symposium on Robot Control (SYROCO 2009), Gifu, Japan, September 10-12, 2009. IPC Member of the 2nd Workshop on Engine Control, Simulation and Modeling (E-COSM'09), Paris, November 2009. IPC Member of the Second International Conference on Robot Communication and Coordination (ROB-OCOMM 2009), Odense, Denmark, March 31-April 2, 2009. Program Co-Chair of 2009 IEEE International Conference on Robotics and Biomimetics (ROBIO 2009), Guilin, Guangxi, China, December 12-15, 2009. IPC Member, Workshop on Dynamical Vision at ICCV 2009, Kyoto, Japan, October 2009. IPC Member, Second Int. Conf. Intelligent Robotics and Applications (ICIRA 2009), 16-18 December 2009, Singapore. IPC Member, International Workshop on Innovation and Commercialization of Micro & Nanotechnology (ICMAN 2009), 21-23 October 2009, Chongqing, Sichuan, China.

Johnsson, Charlotta

IPC Member of the International Program Committee for EI2N'2009.

Rantzer, Anders

Member of the IPC for European Control Conference 2010.

Robertsson, Anders

Program committee member of The Fourth Swedish Workshop on Autonomous Robotics (SWAR'09) Västerås, September 8, 2009. Steering committee member and program committee member of FeBID'09.

Wittenmark, Björn

Member of the International Program Committee (IPC) of 8th IFAC Symposium on Advances in Control Education, October 21-23, 2009, in Kumamoto, Japan.

Longer Visits

Reuterswärd, Philip

In April, Philip was at Texas A&M to work with Prof. Carl Laird and his research group.

Widd, Anders

From September to December Anders was a guest researcher at the Department of Mechanical Engineering at Stanford University working together with Prof. J. Christian Gerdes.

12. Publications and Conference Contributions

This year 1 book, 3 book contributions, 13 articles and 40 conference papers have been published. You can find references to all the publications at www.control.lth.se/publications/ and you can also download many of the publications from this site.

Books

Åström, Karl Johan, Tore Hägglund: *Advanced PID Control*, Pearson Educación, Madrid, 2009.

Book Contributions

Åström, Karl Johan: “Emergence and Development of the Field of Control” in *Sentimentos do Mundo - Ciclo de conferências dos 80 anos da UFMG*, volume pp. 183-210, Humanitas Editora UFMG, May 2009.

Benvenuti, Luca, Andrea Balluchi, Alberto Bemporad, S. Di Cairano, Bengt Johansson, Rolf Johansson, Alberto Sangiovanni-Vincentelli and Per Tunestål: “Chapter 15—Automotive Control” in *Handbook of Hybrid Systems Control, Theory – Tools – Applications*. J. Lunze, F. Lamnabhi-Lagarrigue (Eds.), Cambridge University Press, Cambridge, 2009, pp. 439-469.

Cervin, Anton and Karl-Erik Årzén: “TrueTime: Simulation Tool for Performance Analysis of Real-Time Embedded Systems” in Pieter J. Mosterman, Gabriela Nicolescu (Eds.): *Model-Based Design for Embedded Systems*, CRC Press, November 2009.

Journal Papers

- Crothers, Phil, Philip Freeman, Torgny Brogårdh, Isolde Dressler, Klas Nilsson, Anders Robertsson, Walter Zulauf, Beat Felder, Raimund Loser and Knut Siercks: “Characterisation of the Tau Parallel Kinematic Machine for Aerospace Application”, *SAE Aerospace Engineering & Manufacturing Magazine*, November 2009.
- Ekhholm, Kent, Maria Karlsson, Per Tunestål, Rolf Johansson, Bengt Johansson and Petter Strandh: “Ethanol-Diesel Fumigation in a Multi-Cylinder Engine”, *SAE International Journal of Fuels and Lubricants*, 1:1, pp. 26-36, April 2009.
- Freidovich, Leonid, Pedro La Hera, Uwe Mettin, Anders Robertsson, Anton Shiriaev and Rolf Johansson: “Shaping Stable Periodic Motions of Inertia Wheel Pendulum: Theory and Experiments”, *Asian Journal of Control*, 11:5, pp. 548-556, August 2009.
- Haugwitz, Staffan, Johan Åkesson and Per Hagander: “Dynamic start-up optimization of a plate reactor with uncertainties”, *Journal of Process Control*, 19:4, pp. 686-700, April 2009.
- Herreros, Alberto, Enrique Baeyens Lázaro, Rolf Johansson, Jonas Carlson, José Ramón Perán and S. Bertil Olsson: “Analysis of Changes in the Beat-to-Beat P-wave Morphology Using Clustering Techniques”, *Biomedical Signal Processing and Control*, 4, pp. 309–316, March 2009.
- Johansson, Rolf: “Editorial – Focus on Subspace-based Identification and Its Applications”, *International Journal of Adaptive Control and Signal Processing*, 2009, Vol. 23, No 12, pp. 1051-1052.
- Johansson, Rolf, P. A. Fransson and Måns Magnusson: “Optimal Coordination and Control of Posture and Movements”, *Journal of Physiology—Paris*, 103:3-5, pp. 159-177, October 2009.
- Kjær, Martin Ansbjerg, Maria Kihl and Anders Robertsson: “Resource Allocation and Disturbance Rejection in Web Servers using SLAs and Virtualized Servers”, *Network and Service Management*, IEEE Trans. on, 6:4, December 2009.
- Klar, Axel, Philip Reuterswård and Mohammed Seaid: “A Semi-Lagrangian Method for a Fokker-Planck Equation Describing Fiber Dynamics”, *Journal of Scientific Computing*, 38:3, pp. 349-367, March 2009.
- Sootla, Aivar, Georgios Kotsalis and Anders Rantzer: “Multivariable Optimization-Based Model Reduction”, *IEEE Transactions on Automatic Control*, 54:10, pp. 2477-2480, October 2009.

- Ståhl, Fredrik and Rolf Johansson: “Diabetes Mellitus Modeling and Short-Term Prediction Based on Blood Glucose Measurements”, *Mathematical Biosciences*, Vol. 217, 2009, pp. 101-117.
- Svendenius, Jacob, Magnus Gäfvert, Fredrik Bruzelius and Johan Hultén: “Experimental Validation of the Brush Tire Model”, *Tire Science and Technology*, 37:2, pp. 122-137, June 2009.
- Tabbara, Mohammad, Anders Rantzer, Dragan Netic: “On controller and capacity allocation co-design for networked control systems”, *Systems & Control Letters*, 58, pp. 672-676, 2009.

Conference Contributions

- Åkesson, Johan, Tove Bergdahl, Magnus Gäfvert, Hubertus Tummescheit: “Modeling and Optimization with Modelica and Optimica Using the JModelica.org Open Source Platform” in *Proceedings of the 7th International Modelica Conference 2009*, Modelica Association, September 2009.
- Åkesson, Johan, Hilding Elmqvist, Ulf Nordström: “Dymola and Modelica_EmbeddedSystems in Teaching-Experiences from a Project Course” in *Proceedings of the 7th International Modelica Conference 2009*, Modelica Association, September 2009.
- Åkesson, Johan, Magnus Gäfvert, Hubertus Tummescheit: “JModelica— an Open Source Platform for Optimization of Modelica Models” in *Proceedings of MATHMOD 2009 - 6th Vienna International Conference on Mathematical Modelling*, TU Wien, Vienna, Austria, February 2009.
- Baillio, Brad, Vladimeros Vladimerou: “Multirobot Tethering for Localization and Control” in *Fourth Swedish Workshop on Autonomous Robotics SWAR'09*, Mälardalen University, Västerås, Sweden, September 2009.
- Burgner, C., Zi Yie, Katarina, N., Oropeza, L. Åström, K., Brewer, F., Turner, K.: “Digital Control of Tunneling Accelerometer” in *Sensors, 2009 IEEE*, Christchurch, Australia, 25-28 October, pp. 1824-1827.
- Casella, Francesco, Filippo Donida, Johan Åkesson: “An XML Representation of DAE Systems Obtained from Modelica Models” in *Proceedings of the 7th International Modelica Conference 2009*, Modelica Association, September 2009.
- Cescon, Marzia, Isolde Dressler, Rolf Johansson, Anders Robertsson: “Subspace-based Identification of Compliance Dynamics of Parallel

- Kinematic Manipulator" in *2009 IEEE/ASME International Conference on Advanced Intelligent Mechatronics*, Singapore, July 2009.
- Cescon, Marzia, Rolf Johansson: "Glycemic Trend Prediction Using Empirical Model Identification" in *Proc. Joint 48th IEEE Conference on Decision and Control & Chinese Control Conference (CDC2009 & CCC 2009)*, Shanghai, China, December 16-18, 2009, pp. 3501-3506, December 2009. (CDC2009 & CCC 2009)
- Cescon, Marzia, Fredrik Ståhl, Rolf Johansson: "Subspace-Based Model Identification of Diabetic Blood Glucose Dynamics" in *Proc. 15th IFAC Symposium on System Identification*, July 6-8, 2009, Saint-Malo, France, July 2009.
- Cescon, Marzia, Fredrik Ståhl, Mona Landin-Olsson, Rolf Johansson: "Short-Term Diabetes Blood Glucose Prediction Based On Blood Glucose Measurements" in *Advanced Technologies and Treatments for Diabetes 2009*, Athens, February 2009.
- Cuenca, Angel, Pedro José Garcia Gil, Karl-Erik Årzén, Pedro Albertos: "A Predictor-Observer for a Networked Control System with Time-Varying Delays and Non-Uniform Sampling" in *Proceedings of the European Control Conference*, Budapest, August 2009.
- Giselsson, Pontus, Johan Åkesson, Anders Robertsson: "Optimization of a Pendulum System using Optimica and Modelica" in *Proceedings of the 7th International Modelica Conference 2009*, Modelica Association, September 2009.
- Guzmán, José Luis, Karl Johan Åström, Tore Hägglund, Sebastián Dormido, Manuel Berenguel, Yves Pigué: "Interactive Learning Module for Control Interaction Understanding" in *European Control Conference*, Budapest, Hungary, August 2009.
- Haage, Mathias, Isolde Dressler, Anders Robertsson, Klas Nilsson, Torgny Brogårdh, Rolf Johansson: "Reconfigurable Parallel Kinematic Manipulator for Flexible Manufacturing" in *Proc. 13th IFAC Symposium on Information Control Problems in Manufacturing (INCOM2009)*, June 3-5, 2009, Moscow, Russia, June 2009. Best Paper Award.
- Hast, Martin, Johan Åkesson, Anders Robertsson: "Optimal Robot Control using Modelica and Optimica" in *Proceedings of the 7th International Modelica Conference 2009*, Modelica Association, September 2009.
- Hedin, Görel, Emma Nyman-Nilsson, Johan Åkesson: "A Plan for Building Renaming Support for Modelica in *WRT'09*, Orlando, Florida, USA, October 2009.

- Henningsson, Toivo, Anton Cervin: “Comparison of LTI and Event-Based Control for a Moving Cart with Quantized Position Measurements” in *Proceedings of the European Control Conference*, Budapest, Hungary, August 2009.
- Johansson, Rolf: “Continuous-Time Model Identification and State Estimation Using Non-Uniformly Sampled Data” in *Proc. 15th IFAC Symposium on System Identification (SYSID2009)*, July 6-8, 2009, Saint-Malo, France, July 2009.
- Johansson, Rolf, Magnus Annerstedt, Anders Robertsson: “Stability of Haptic Obstacle Avoidance and Force Interaction” in *Proc. 2009 IEEE/RSJ International Conference on Intelligent Robots and Systems (IROS2009)*, 2009 St. Louis, USA, pp. 3238-3243, October 2009.
- Johansson, Rolf, Anders Robertsson: “Stability of Robotic Obstacle Avoidance and Force Interaction” in *Preprints 9th IFAC International Symposium on Robot Control (SYROCO'09)*, Gifu, Japan, September 9-12, 2009, pp. 709-714, September 2009.
- Jörntell, Henrik, Per-Ola Forsberg, Fredrik Bengtsson, Rolf Johansson: “Mathematical Modeling of Brain Circuitry during Cerebellar Movement Control” in *Proceedings of the 2009 IEEE International Conference on Robotics and Biomimetics (ROBIO2009)*, Guilin, China, pp. 98-103, December 2009.
- Kjær, Martin Ansbjerg, Anders Robertsson: “Effects of Neglecting Buffers in Feed-Forward Design for Web Servers” in *Proc. Fourth International Workshop on Feedback Control Implementation and Design in Computing Systems and Networks (FeBID'09)*, San Francisco, CA, April 2009. pp. 61—68.
- Larsson, Per-Ola, Tore Hägglund: “Robustness Margins Separating Process Dynamics Uncertainties” in *European Control Conference*, August 2009.
- Linderöth, Magnus, Anders Robertsson, Kalle Åström, Rolf Johansson: “Vision Based Tracker for Dart-Catching Robot” in *Preprints 9th IFAC International Symposium on Robot Control (SYROCO'09)*, Gifu, Japan, pp. 883-888, September 2009.
- Matsuda, N., Izutsu, M., Ishikawa, J., Furuta, K., Åström, K.J.: “Swinging-up and Stabilization Control based on Natural Frequency for Pendulum Systems” in *American Control Conference, ACC'09*, Saint-Louis, MO, US, June 2009, pp. 5291-5296.
- Moran, K., DeMartini, B.E., Turner, K.L. Åström, K.J.: “Frequency Resolution of a Multi Degree of Freedom Resonator” in *Sensors, 2009 IEEE*, Christchurch, Australia, October 2009, pp. 865-868.

- Nilsson, Oskar, Anders Rantzer: “A novel approach to balanced truncation of nonlinear systems” in *Proceedings of The European Control Conference*, Budapest, Hungary, August 2009.
- Nilsson, Oskar, Anders Rantzer: “A Novel Nonlinear Model Reduction Method Applied to Automotive Controller Software” in *Proceedings of the American Control Conference*, St. Louis, Missouri, USA, June 2009.
- Rantil, Jens, Johan Åkesson, Claus Führer, Magnus Gäfvert: “Multiple-Shooting Optimization using the JModelica.org Platform” in *Proceedings of the 7th International Modelica Conference 2009*, Modelica Association, September 2009.
- Rantzer, Anders: “Dynamic Dual Decomposition for Distributed Control” in *Proceedings of American Control Conference*, St. Louis, June 2009.
- Reuterswård, Philip, Johan Åkesson, Anton Cervin, Karl-Erik Årzén: “TrueTime Network—A Network Simulation Library for Modelica” in *Proceedings of the 7th International Modelica Conference 2009*, Modelica Association, September 2009.
- Samii, Soheil, Anton Cervin, Petru Eles, Zebo Peng: “Integrated Scheduling and Synthesis of Control Applications on Distributed Embedded Systems” in *Proc. Design, Automation & Test in Europe (DATE'09)*, April 2009.
- Samii, Soheil, Petru Eles, Zebo Peng, Anton Cervin: “Quality-Driven Synthesis of Embedded Multi-Mode Control Systems” in *Proc. 46th Design Automation Conference (DAC)*, San Francisco, CA, July 2009.
- Sootla, Aivar and Anders Rantzer: “Extensions to an Optimization-Based Multivariable Reduction Method”, in *Proceedings of the European Control Conference*, August 2009.
- Shiriaev, Anton, Rolf Johansson, Anders Robertsson, Leonid Freidovich: “Criteria for Global Stability of Coupled Systems with Application to Robust Output Feedback Design for Active Surge Control” in *Proc. 2009 IEEE Multi-conference on Systems and Control (MSC 2009)*, 8-10 July 2009, Saint Petersburg, Russia, July 2009.
- Shiriaev, Anton, Rolf Johansson, Anders Robertsson, Leonid Freidovich: “Feedback Control Design for the 3-state Moore-Greitzer Compressor Model” in *Proc. 3rd IEEE Multi-conference on Systems and Control (MSC 2009)*, Saint Petersburg, Russia. July 8-10, 2009, July 2009.
- Ståhl, Fredrik, Marzia Cescon, Rolf Johansson, Eric Renard: “Infinite Horizon Prediction of Post Prandial Breakfast Glucose Excursion” in *Diabetes Technology Meeting 2009*, San Francisco, November 2009.

Chapter 12. Publications and Conference Contributions

- Widd, Anders, Kent Ekholm, Per Tunestål, Rolf Johansson: “Experimental Evaluation of Predictive Combustion Phasing Control in an HCCI Engine using Fast Thermal Management and VVA” in *Proc. 2009 IEEE Multi-Conference on Systems and Control*, Saint Petersburg, Russia, July 2009.
- Wilhelmsson, Carl, Per Tunestål, Bengt Johansson, Anders Widd, Rolf Johansson: “A Physical Two-Zone NOx Model Intended for Embedded Implementation” in *SAE Technical Papers 2009-01-1509*, SAE World Congress & Exhibition, April 2009, Detroit, MI, USA, April 2009. (Also in *Modeling of SI and Diesel Engines*, Vol. SP-2244, 2009, ISBN 978-0-7680-2140-0, April 2009)
- Wilhelmsson, Carl, Per Tunestål, Anders Widd, Rolf Johansson: “A Fast Physical NOx Model Implemented on an Embedded System” in *Proc. IFAC Workshop on Engine and Powertrain Control, Simulation and Modeling (ECoSM 2009)*, Nov 30-Dec 2, 2009, Malmaison, Rueil, France, November 2009.
- Zi Yie, Katarina, N., Burgner, C., Åström, K.J., Brewer, F., Turner, K.: “Control Design for Force Balance Sensors” in *American Control Conference*, 2009 ACC'09, Saint-Louis, MO, US, 10-12 June, pp. 743-1619.

13. Reports

During this year 2 PhD theses have been published. The abstracts are presented in Chapter 7. Also 3 Licentiate theses, 16 Master's theses and 2 internal reports have been completed.

PhD Theses

Kjaer, Martin Ansbjerg: *Disturbance Rejection and Control in Web Servers*. PhD thesis ISRN LUTFD2/TFRT--1086--SE, Department of Automatic Control, Lund University, Sweden, November 2009.

Nilsson, Oskar: *On Modeling and Nonlinear Model Reduction in Automotive Systems*. PhD thesis ISRN LUTFD2/TFRT--1085--SE, Department of Automatic Control, Lund University, Sweden, March 2009.

Licentiate Theses

Garpinger, Olof: *Design of Robust PID Controllers with Constrained Control Signal Activity*. Licentiate thesis ISRN LUTFD2/TFRT--3245--SE, Department of Automatic Control, Lund University, Sweden, March 2009.

Sootla, Aivar: *Model Reduction Using Semidefinite Programming*. Licentiate thesis ISRN LUTFD2/TFRT--3247--SE, Department of Automatic Control, Lund University, Sweden, November 2009.

Widd, Anders: *Predictive Control of HCCI Engines using Physical Models*. Licentiate thesis ISRN LUTFD2/TFRT--3246--SE, Department of Automatic Control, Lund University, Sweden, May 2009.

Master's Theses

E = Examiner

S = Supervisor

AC = Department of Automatic Control, LTH

TM = Project within the Technology Management Course

Amanatbari, Siavosh: “Control of Isothermal Calorimeter” Master's thesis ISRN LUTFD2/TFRT--5836--SE, Department of Automatic Control, Lund University, Sweden, May 2009. E: Rolf Johansson, AC; S: Lars Wadsö, Building Materials, Lund.

Andersson, Ida and Linn Andersson: “How to create an organizational culture that promotes innovation – A case study at Siemens Industrial Turbomachinery AB”. TM.

Basson, Timothée and Julien Lescot: “Model-based Friction Compensation” Master's thesis ISRN LUTFD2/TFRT--5839--SE, Department of Automatic Control, Lund University, Sweden, June 2009. E: Rolf Johansson, AC; S: Anders Robertsson, AC, Germain Garcia, INSAT, France and Carlos Canudas-de-Wit, INPG, France.

Collryd, Marcus and Peter Svensson Valdt: “Temperature Control of an External Cleaning Unit” Master's thesis ISRN LUTFD2/TFRT--5845--SE, Department of Automatic Control, Lund University, Sweden, December 2009. E: Tore Hägglund, AC; S: Daniel Cederström, Tetra Pak, Lund.

Eriksson, Daniel and Manfred von Richthofen: “The Connected Home - A smart marketing quest”. TM.

Eriksson, Fredrik and Marcus Welander: “Haptic Interface for a Contact Force Controlled Robot” Master's thesis ISRN LUTFD2/TFRT--5837--SE, Department of Automatic Control, Lund University, Sweden, May 2009. E: Rolf Johansson, AC; S: Anders Robertsson, AC.

Gunnarsson-Eriksson, Emanuel and Erik Ekström: “How to become the Leader in the Mobile Telecom Industry”. TM.

Hast, Martin: “Optimal Control and Path Following for Industrial Robots” Master's thesis ISRN LUTFD2/TFRT--5842--SE, Department of Automatic Control, Lund University, Sweden, June 2009. E: Rolf Johansson, AC; S: Anders Robertsson, AC and Johan Åkesson, AC.

Hess, Anne-Kathrin: “A Distributed Kalman Filter Algorithm for Self-localization of Mobile Devices” Master's thesis ISRN LUTFD2/TFRT--5843--SE, Department of Automatic Control, Lund University, Sweden, August 2009. E: Anton Cervin, AC; S: Rolf Findeisen, Inst for

- Automation Eng. Lab. for Systems Theory and Control, Magdeburg, Germany and Anders Rantzer, AC.
- Herget, Julia: "Predictive Models for Type 1 Diabetes. A Case Study" Master's thesis ISRN LUTFD2/TFRT--5838--SE, Department of Automatic Control, Lund University, Sweden, May 2009. N.B. Bachelor's Thesis E: Rolf Johansson, AC; S: Ulrich Konigorski, Technische Univ. Darmstadt, Germany.
- Håkansson, Ambjörn and Hugo Lang: "Allocating IPR Generated in R&D Collaboration with Chinese Universities". TM.
- Israelsson, Henrik and Leonardo Bello: "Configuration Management for Industrial Automation" Master's thesis ISRN LUTFD2/TFRT--5835--SE, Department of Automatic Control, Lund University, Sweden, June 2009. E: Karl-Erik Årzén, AC; S: Magnus Wendt, Tetra Pak Processing Systems, Lund and Charlotta Johansson, AC.
- Johansson, Lars: "Dynamic Simulation and Modeling of Hydropower Plants" Master's thesis ISRN LUTFD2/TFRT--5840--SE, Department of Automatic Control, Lund University, Sweden, June 2009. E: Karl-Erik Årzén, AC; S: Frida Ekström, Solvina AB, Gothenburg.
- Johnsson, Jimmie and Johan Ekholm: "Value Capturing in Open Source Projects". TM.
- Karlsson, Anna and John Blomsterlind: "Exploring Value Potential in a Function-Focused Industry". TM.
- Karlsson, Don and Gustav Eriksson: "The economics of Arctic offshore oil". TM.
- Krasse, Caroline and Hanna Fredriksson: "Environmental Performance & Reporting at Scania - A Study of How Scania Sales & Services Can Meet Increased Environmental Demands". TM.
- Larsson, Mathias and Petter Johansson: "Kommersiell och strategisk syn på mjukvaruuppdateringar av inbyggda system inom fordonsindustrin". TM.
- Lindberg, Carl and Johan Wachtmeister: "Att uppnå kundfokus i en bankverksamhet". TM.
- Lindholm, Anna: "Buffer Management Strategies for Improving Plant Availability" Master's thesis ISRN LUTFD2/TFRT--5832--SE, Department of Automatic Control, Lund University, Sweden, January 2009. E: Charlotta Johansson, AC; S: Krister Forsman, Perstorp AB.
- Lundgren, Robin and Tim Larsson: "The Power of Knowing". TM.
- Lundin, Daniel and Sofia Lindelöw: "Kvantifiering av nyttan med mobilt arbetssätt". TM.

Chapter 13. Reports

- Olsson, André: "Modeling and control of a Delta-3 robot" Master's thesis ISRN LUTFD2/TFRT--5834--SE, Department of Automatic Control, Lund University, Sweden, February 2009. E: Rolf Johansson, AC; S: Wolfgang Reinelt, ELAU, GmbH, Germany and Anders Robertsson, AC.
- Palm, Anders and Mattias Wesslau: "Konsekvenser av tredjepartstillträde för en lokal fjärrvärmemarknad – En fallstudie av fjärrvärmenätet i Helsingborg". TM.
- Persson, Emilie and Emma Jönsson: "Framgångsrik tillväxt". TM
- Pålsson, Johan and Sandra Petersson: "How to become the Leader in the Mobile Telecom Industry". TM.
- Rosdahl, Louice and Simon Quick: "Increased Supply Chain Flexibility by Changes in Information Sharing with Suppliers – The FAIS Roadmap". TM.
- Rosengren, Anna, Caroline Anjou and Elisabeth Andersson: "SCORing high on Alfa Laval - Creating a management system framework for implementation of common workflows". TM.
- Rytoft, Anna and Lena Strömberg: "Industrial Landscaping of District Heating – Opportunities for knowledge transfer to the UK market". TM.
- Schiffer, Johannes: "Dual motor control for backlash reduction" Master's thesis ISRN LUTFD2/TFRT--5841--SE, Department of Automatic Control, Lund University, Sweden, June 2009. E: Anders Rantzer, AC and F. Allgöwer, Systems Theory and Automatic Control, Univ. of Stuttgart, Germany; S: Anders Robertsson, AC and S. Schuler, Systems Theory and Automatic control, Univ. of Stuttgart, Germany.
- Stemann, Meike: "Simulation and Analysis of a Power Supply Circuit for Frequency Inverter Controlled AC-Induction Motors" Master's thesis ISRN LUTFD2/TFRT--5844--SE, Department of Automatic Control, Lund University, Sweden, November 2009. E: Rolf Johansson, AC; S: Manfred Kasper, Inst. für Mikrosystemtechnik, Technische Universität Hamburg-Harburg, Germany and Ingenjörfirman Ragnar Jönsson, Ystad.
- Stolt, Andreas: "Control of the Degassing System in a Dialysis Machine" Master's thesis ISRN LUTFD2/TFRT--5846--SE, Department of Automatic Control, Lund University, Sweden, December 2009. E: Rolf Johansson, AC; S: Jan Sternby, Gambro.
- Söderström, Lisa and Stina Slottsjö: "Brand Equity of High Technology Companies in a B2B Context". TM.

- Sörnmo, Olof: “Force Controlled Grinding - The Cutting Edge” Master's thesis ISRN LUTFD2/TFRT--5848--SE, Department of Automatic Control, Lund University, Sweden, December 2009. E: Rolf Johansson, AC; S: Anders Robertsson, AC.
- Tornberg, Anton and Christoffer Berg: “Analyzing standardization, modularization and customization, piece by piece - Abetong and the case of industrial house building”. TM.
- Wåhlin, Fredrik: “Developing graphical user interface for a model predictive controller in an ABB software environment” Master's thesis ISRN LUTFD2/TFRT--5833--SE, Department of Automatic Control, Lund University, Sweden, February 2009. E: Tore Hägglund, AC; S: Per-Erik Modén, ABB, Västerås.

Internal Reports

- Kotsalis, Georgios and Anders Rantzer: “Balance Truncation for Discrete Time Markov Jump Linear Systems” Technical report ISRN LUTFD2/TFRT--7621--SE, Department of Automatic Control, Lund University, Sweden, October 2009.
- Westin, Eva and Tore Hägglund (eds.): “Automatic Control Activity Report 2008” Technical report ISRN LUTFD2/TFRT--4036--SE, Department of Automatic Control, Lund University, Sweden, April 2009.

Report Availability

Almost all our publications are available in full through our web server at www.control.lth.se/publications.

Only a limited number of copies of our reports are available for sale from the department. Any of the listed reports may, however, be borrowed through your library service or from the following libraries in Sweden.

- Linköpings Universitetsbibliotek, Svensktrycket, SE-581 83 Linköping
- Universitetsbiblioteket Lund, Svenska Tryckavdelningen, Box 1010, SE-221 03 Lund

Chapter 13. Reports

- Stockholms Universitetsbibliotek, Svenska Tryckavdelningen, SE-106 91 Stockholm
- Kungliga Biblioteket, Box 5039, SE-102 41 Stockholm
- Umeå Universitetsbibliotek, Box 718, SE-901 10 Umeå
- Uppsala Universitetsbibliotek, Box 510, SE-751 20 Uppsala

The reports in the 1000- and 3000-series may be ordered from the department (see address on page 2). Please be certain to specify both the number(s) and the title(s) of the report(s). There is a copying and handling charge of between 300 and 500 SEK for each document. Invoice will be sent together with the ordered report(s).

The Master's Thesis Reports presented within the Technology Management Course are available on

http://www.tmonline.se/master_theses/index

14. Lectures by the Staff Outside the Department

Åkesson, Johan

JModelica—an Open Source Platform for Optimization of Modelica Models, MATHMOD 2009 - 6th Vienna International Conference on Mathematical Modelling, Vienna, Austria. February 16.

JModelica.org-an Open Source Platform for Optimization of Modelica Models, 14th Belgian-French-German Conference on Optimization, Leuven, Belgium. September 15.

Modeling and Optimization with Modelica and Optimica Using the JModelica.org Open Source Platform, 7th International Modelica Conference 2009, Como, Italy. September 21.

Dymola and Modelica Embedded Systems in Teaching-Experiences from a Project Course, 7th International Modelica Conference 2009, Como, Italy. September 22.

Årzén, Karl-Erik

Cyber-Physical Systems: Fundamentals. Invited address at Cyber-Physical Systems Week, San Francisco, CA, USA. April 16.

On Verification and Validation of Real-Time Control Systems: Formal Approaches vs Simulation. Invited presentation at Caltech Verification & Validation Workshop, Pasadena. September 23.

On Automatic Code Generation for Control Applications. Workshop on Software Synthesis, Embedded Systems Week, Grenoble, France. October 16.

Åström, Karl Johan

Control - The Hidden Technology. Ming Hsieh Distinguished Lecture. University of Southern California. March 25.

A Future for Control? Delft Center for Systems and Control. Delft, The Netherlands. April 22.

Chapter 14. Lectures by the Staff Outside the Department

- The Future of Control.* Department of Information Technology and Electrical Engineering. ETH, Zürich, Switzerland. October 7.
- Event Based Control.* Department of Mechanical and Process Engineering. ETH, Zürich, Switzerland. October 8.
- The Future of Control - Some personal reflections.* International Workshop on the Impact of Control: Past, Present, and Future. Berchtesgaden Oct 18-19. October 19.
- Event Based Control.* Lehrstuhl für Steuerungs- und Regelungstechnik. Fakultät für Elektrotechnik und Informationstechnik Technische Universität München. October 21.
- Event Based Control.* Distinguished Lecture Series. Department of Computer Science. University of Illinois. Urbana Champaign. November 2.
- The Future of Control.* R. T. Chien Distinguished Lecture. Coordinated Science Laboratory. University of Illinois. Urbana Champaign. November 4.
- The Future of Control.* The Mathworks. Natick, Massachusetts, USA. November 11.
- Challenges in Control.* Paths Ahead in the Science of Information and Decision Systems. Laboratory for Information and Decision Systems. MIT, USA. November 13.
- Control Design for Force Feedback of MEMS Instruments.* Workshop on Dynamics and Control of Micro and Nanoscale Systems. IBM Zurich Research Laboratory, Rueschlikon, Switzerland. December 10.

Cervin, Anton

- Embedded Real-Time Computing and Control.* PhD course at the Department of Computer and Information Science, Linköping University, February 12-13.
- Integrated Control and Scheduling; Fixed-Point Arithmetic; Networked Control Systems.* ArtistDesign Graduate Course on Embedded Control Systems, Scuola Superiore Sant'Anna, Pisa, June 10-11.
- Short Course on Event-Based Control.* PhD course at the Department of Systems Engineering and Control, Universidad Politécnica de Valencia, June 22-24.
- Event-Based Control with Stochastic Disturbances.* Invited lecture at the Department of Computer Science and Automatic Control, Universidad Nacional de Educación a Distancia, Madrid, June 25.
- Simulation of Networked Control Systems.* 3rd WIDE PhD School on Networked Control Systems, Siena, July 8.

Event-Based Control over Networks. Real-Time in Sweden, Lund, August 19.

Comparison of LTI and Event-Based Control for a Moving Cart with Quantized Position Measurements. European Control Conference, Budapest, August 26.

Cescon, Marzia

Glycemic Trend Prediction Using Empirical Model Identification. Joint 48th IEEE Conference on Decision and Control & Chinese Control Conference (CDC2009 & CCC 2009), Shanghai, China, December 16-18.

Subspace-Based Model Identification of Diabetic Blood Glucose Dynamics. 15th IFAC Symposium on System Identification, Saint-Malo, France. July 6-8.

Subspace-based Identification of Compliance Dynamics of Parallel Kinematic Manipulator. 2009 IEEE/ASME International Conference on Advanced Intelligent Mechatronics, Singapore. July 2009.

Parallel Kinematic Manipulator Dynamics, invited speaker, 2nd Wissenschaftskolloquium, Campus Kuenzeslau. November 17.

Hägglund, Tore

Advanced PID Control, PhD course, University of Almeria, Almeria, Spain, March 9–13.

Automatic on-line estimation of backlash in control loops, Helsinki University of Technology, Helsinki, Finland, October 10.

Johansson, Rolf

Hybrid Control of Homogeneous Charge Compression Ignition (HCCI) Combustion Engines, Workshop on Automotive Model Predictive Control: Models, Methods and Applications. Invited Lecture. Linz-Feldkirchen, Austria, February 9.

Hybrid Control of Homogeneous Charge Compression Ignition (HCCI) Combustion Engines, FP7-ICT & HYCON Concertation Meeting on Monitoring and Control for Energy Efficiency. Invited Lecture. Brussels, 4 March 4.

Reglerteknik som Hjälpmedel för Diabetiker, Lund Alliance for Biomedical Engineering, Lund University, Lund, May 28.

Reconfigurable Parallel Kinematic Manipulator for Flexible Manufacturing, 13th IFAC Symposium on Information Control Problems in Man-

Chapter 14. Lectures by the Staff Outside the Department

- ufacturing (INCOM2009), V.A. Trapeznikov Institute of Control Sciences of the Russian Academy of Sciences, Moscow, Russia, June 3.
- Force-Controlled Drilling Using Industrial Robot Assembly Operations*, Korea-Sweden Robotics Symposium, Lund University, Lund, June 9.
- Modeling and Model-Based Control of Homogeneous Charge Compression Ignition (HCCI) Engine Dynamics*, HYCON-NESTER Workshop, Milan, Italy, July 4.
- Continuous-Time Model Identification and State Estimation Using Non-Uniformly Sampled Data*, Proc. 15th IFAC Symposium on System Identification (SYSID2009). Invited Lecture. Saint-Malo, France, July 7.
- Stability of Robotic Obstacle Avoidance and Force Interaction*, 9th International Symposium on Robot Control (SYROCO'09), The International Federation of Automatic Control, Gifu, Japan, September 12.
- Stability of Haptic Obstacle Avoidance and Force Interaction*, 2009 IEEE/RSJ International Conference on Intelligent Robots and Systems (IROS2009), St. Louis, USA, October 13.
- MEMS & Nano-Technology, Industrialization and Commercialization in Sweden*, International Workshop on Innovation and Commercialization of Micro & Nanotechnology (ICMAN 2009). Invited Lecture. Chongqing, Sichuan, China, October 23 .
- Curriculum and Education in Computer-Controlled Systems*. Invited Lecture. Tsinghua University, Dept. Precision Instruments and Mechnology, Beijing, China, October 26.
- Separation Principle for a Class of Nonlinear Feedback Systems Augmented with Observers*, Center for Control, Dynamical Systems, and Computation, University of California at Santa Barbara (UCSB), November 3.
- Mathematical Modeling of Brain Circuitry during Cerebellar Movement Control, 2009 IEEE International Conference on Robotics and Biomimetics (ROBIO2009), Guilin, China, December 20.

Johnsson, Charlotta

- "Standarder som spar pengar (Standards that saves money)" Invited speaker. Charlotta participated at the Process Nordic conference around Industrial IT and Automation. November 24-25.

Larsson, Per-Ola

Relations Between Control Signal Properties and Robustness Measures, Nordic Process Control Workshop, Telemark University College, Porsgrunn, Norway, January 29-30.

Robustness Margins Separating Process Dynamics Uncertainties, European Control Conference, Budapest, Hungary, August 23-26.

Rantzer, Anders

Distributed Control using Decompositions and Games, Mathematisches Forschungsinstitut Oberwolfach. February 26.

On Distributed Control Synthesis using Dynamic Dual Decomposition, Technion, Haifa, Israel. March 30.

Dagsaktuell forskning i reglerteori, IVA-möte i Lund, April 16.

Distributed Verification of Sparse Systems, 1st LCCC Workshop, Lund. May 29.

Distributed Control using Decompositions and Games, Stanford University, USA. June 6.

Distributed Control using Decompositions and Games, Caltech, USA. June 8.

Dynamic Dual Decomposition for Distributed Control, American Control Conference, St. Louis, USA. June 10.

Distributed Procedures for Control Synthesis, A Celebration of the Field of Systems and Control - An international symposium at KTH, Stockholm. September 11.

Using Adjoint Variables for Decomposition of MPC Controllers, 14th Belgian-French-German Conference on Optimization, Leuven, Belgium. September 14.

Distributed Model Predictive Control with Suboptimality Bounds, Aalborg University, Denmark. September 17.

Distributed Procedures for Control Synthesis, 1st IFAC Workshop on Estimation and Control of Networked Systems, Venice, Italy. September 25.

Building Theoretical Foundations for Distributed Control, Seminar at Centre for Mathematical Sciences, Lund. October 16.

Robertsson, Anders

Invited lecture *The SMErobot-project*. The 4th Swedish Workshop on Autonomous Robotics, SWAR'09 Västerås. September 8.

Graduate course on *Advanced Robotics* at UPV, Polytechnical University of Valencia, Spain. June 24-26.

Chapter 14. Lectures by the Staff Outside the Department

Effects of Neglecting Buffers in Feed-Forward Design for Web Servers, San Francisco, CA Fourth International Workshop on Feedback Control Implementation and Design in Computing Systems and Networks (FeBID'09). April 16.

Several popular science lectures at “Natur och Teknikdagarna” and “Flickor på Teknis” and exhibitions at the Science Center “Vattenhallen”, LTH.

Widd, Anders

Experimental Evaluation of Predictive Combustion Phasing Control in an HCCI Engine using Fast Thermal Management and VVA. 2009 IEEE Multi-Conference on Systems and Control, St. Petersburg, Russia. July 9.

15. Seminars at the Department

Seminars are presented in order of date. The seminars were given at the department during 2008, both by the staff and invited lecturers. Dissertations and master's theses presentations are also included.

AC = Department of Automatic Control, LTH

LU = Lund University

Jan 22: Anna Lindholm (LU), *Buffer management strategies for improving plant availability*. MSc-thesis presentation.

Jan 27: Fredrik Wåhlin (LU), *Developing graphical user interface for a model predictive controller in an ABB software environment*, MSc-thesis presentation.

Mar 2: André Olsson (LU), *Modeling and control of a Delta-3 robot*. MSc-thesis presentation.

Mar 5: Per-Olof Gutman (Technion, Israel), *Robust stabilization of an unmanned motorcycle*.

Mar 5: Jacquélien Scherpen (University of Groningen, The Netherlands), *A power based perspective for modeling and control of nonlinear systems*.

Mar 6: Oskar Nilsson (AC), *On Modeling and Nonlinear Model Reduction in Automotive Systems*. Defence of Doctoral Dissertation.

Mar 25: Vladimeros Vladimerou (AC), *Specifications for Decidable Hybrid Automata and Games*.

Mar 26: Henrik Israelsson and Leonardo Bello (LU), *Configuration Management for Industrial Automation - a case study at TetraPak Processing Systems*. MSc-thesis presentation.

Mar 26: Yifan Wu, (Scuola Superiore Sant'Anna, Pisa, Italy), *Resource Reservation for Static CAL Application on Multi-core Systems*.

Mar 27: Olof Garpinger, (AC), *Design of Robust PID Controllers with Constrained Control Signal Activity*. Licentiate Seminar.

Apr 14: Ahmed El-Shaer (AC), *Robust Control Design of Electric Power Steering Systems*.

Chapter 15. Seminars at the Department

- May 7: Frank Allgöwer (Institute for Systems Theory and Automatic Control, University of Stuttgart, Germany), *Systems Biology: A New Scientific Discipline at the Interface of Systems Theory and Biology*.
- May 11: Fredrik Eriksson and Marcus Welandar (LU), *Haptic Interface for a Contact Force Controlled Robot*. MSc-thesis presentation.
- May 20: Julia Herget (Germany), *Predictive Models for Type-I Diabetes: A Case Study*. MSc-thesis presentation.
- May 20: Lars Johansson (LU), *Dynamisk simulering och modellering av vattenkraftverk*. MSc-thesis presentation.
- May 25: Anders Widd (AC), *Predictive Control of HCCI Engines using Physical Models*. Licentiate Seminar.
- May 25: Lars Eriksson (Linköpings Universitet, ISY), *Modellering för analys och reglering av turbomotorer*.
- May 26: Johannes Schiffer (Germany), *Dual motor control for backlash reduction*. MSc-thesis presentation.
- Jun 1: Martin Hast (LU), *Optimal control and path following for industrial robots*. MSc-thesis presentation.
- Jun 3: Timothée Basson and Julien Lescot (France), *Model-Based Friction Compensation*. MSc-thesis presentation.
- Jun 18: John Morrell (Department of Mechanical Engineering, Yale University), *Inverted Pendulums and Humans in the Loop*.
- Aug 10: Anne-Kathrin Hess (Germany), *A Distributed Kalman Filter Algorithm for Self-localization of Mobile Devices*. MSc-thesis presentation.
- Aug 28: Pepe Maestre Torreblanca (Universidad Politécnica de Madrid, Spain), *Distributed model predictive control and interoperability in smart home*.
- Sep 7: Graham C. Goodwin (University of Newcastle, UK), *Variance or Spectral Density in Sampled Data Filtering?*
- Sep 16: Alexandra Grancharova (Bulgarian Academy of Sciences), *Explicit Nonlinear Model Predictive Control*.
- Sep 16: Lachlan Blackhall (Australian National University), *Recursive Sparse Estimation using a Gaussian Sum Filter*.
- Oct 8: Meike Stemmann (Germany), *Simulation and Analysis of a Power Supply Circuit for Frequency Inverter Controller AC-Induction Motors*. MSc-thesis presentation.
- Oct 9: Rudy Negenborn (Delft Center for Systems and Control, Delft University of Technology, The Netherlands), *Distributed Model Predictive Control for Electricity and Water Infrastructures*.

- Oct 22: Clas Jacobson (Chief Scientist, Controls, United Technologies Corporation, USA), *Energy Efficient Buildings A Systems Approach R&D Directions*.
- Oct 26: Mustafa Khammash (Professor, Dept. Mechanical Engineering, University of California at Santa Barbara, USA), *Listening to the noise: stochastic fluctuations in molecular biology*.
- Nov 19: Tarek Abdelzaher (University of Illinois at Urbana Champaign, USA), *Research Challenges in Distributed Cyber-Physical Systems*.
- Nov 20: Martin Ansbjerg Kjær (AC), *Disturbance Rejection and Control in Web Servers*. Defence of Doctoral Dissertation.
- Nov 26: Marcus Collryd and Peter Svensson Valdt (LU), *Predictive Temperature Control of an External Cleaning Unit*. MSc-thesis presentation.
- Nov 27: Olof Sörnmo (LU), *Force Controlled Grinding -- The Cutting Edge*. MSc-thesis presentation.
- Nov 27: Aivar Sootla (AC), *Model Reduction Using Semidefinite Programming*. Licentiate Seminar.
- Nov 27: Per-Ola Forsberg (LU), *Identification and Modeling of Sensory Feedback Processing in a Brain System for Voluntary Movement Control*. MSc-thesis presentation.
- Dec 3: Andreas Stolt (LU), *Control of the Degassing System in a Dialysis Machine*. MSc-thesis presentation.
- Dec 10: The Hagander Seminar in Automatic control.
- Dec 14: Kimberly Turner (Department of Mechanical Engineering, University of California, Santa Barbara, USA), *Using Nonlinearity to Improve Sensor Performance*.