



LUND UNIVERSITY

Application of ozone in wastewater treatment

Oxidation of pharmaceuticals and filamentous bulking sludge

Nilsson, Filip

2017

Document Version:

Publisher's PDF, also known as Version of record

[Link to publication](#)

Citation for published version (APA):

Nilsson, F. (2017). *Application of ozone in wastewater treatment: Oxidation of pharmaceuticals and filamentous bulking sludge* (1 ed.). [Doctoral Thesis (compilation)]. Department of Chemical Engineering, Lund University.

Total number of authors:

1

General rights

Unless other specific re-use rights are stated the following general rights apply:

Copyright and moral rights for the publications made accessible in the public portal are retained by the authors and/or other copyright owners and it is a condition of accessing publications that users recognise and abide by the legal requirements associated with these rights.

- Users may download and print one copy of any publication from the public portal for the purpose of private study or research.
- You may not further distribute the material or use it for any profit-making activity or commercial gain
- You may freely distribute the URL identifying the publication in the public portal

Read more about Creative commons licenses: <https://creativecommons.org/licenses/>

Take down policy

If you believe that this document breaches copyright please contact us providing details, and we will remove access to the work immediately and investigate your claim.

LUND UNIVERSITY

PO Box 117
221 00 Lund
+46 46-222 00 00



Application of ozone in wastewater treatment

Oxidation of pharmaceuticals and filamentous
bulking sludge

FILIP NILSSON

WATER AND ENVIRONMENTAL ENGINEERING | LUND UNIVERSITY



Application of ozone in wastewater treatment

Oxidation of pharmaceuticals and filamentous bulking sludge

Filip Nilsson



LUND
UNIVERSITY

DOCTORAL DISSERTATION

by due permission of the Faculty of Engineering, Lund University, Sweden.
To be defended in lecture hall K:A, Kemicentrum on the 2nd of February 2018
at 13:15

Faculty opponent

Ph. D. Dines Thornberg, BIOFOS AS, Denmark

Organization LUND UNIVERSITY	Document name DOCTORAL THESIS	
Water and Environmental Engineering at the Department of Chemical Engineering	Date of issue 2018-02-02	
Author(s) Filip Nilsson	Sponsoring organization: Primozone Production AB, Svenskt Vatten (via VA-teknik Södra)	
Title and subtitle: Application of ozone in wastewater treatment – Oxidation of pharmaceuticals and filamentous bulking sludge		
<p>Abstract</p> <p>As pharmaceutical removal was not part of the of the modern wastewater treatment plant (WWTP) design, it is not surprising that WWTPs have been identified as major point sources of pharmaceuticals entering the environment. The oxidation of pharmaceuticals in the WWTP effluent is one of the-end-of-pipe solutions that are considered most ready for full-scale use. However, there are several aspects of its application that must be further researched. One aim of this thesis project was to investigate how effective ozone is when applied to different WWTPs. When ozone was applied to the effluent of Lundåkraverket WWTP, the importance of the organic carbon content was highlighted. A pre-treatment that removed most of the organic carbon (suspended solids) removed 95% of the total pharmaceutical concentration with an ozone dose of five g O₃/m³. Without this pre-treatment, the removal reached 80% with the same ozone dose. Moreover, the impact of TOC was substantial when ozone was applied in the same manner at ten different WWTPs; as the TOC content in the wastewater effluent increases, a higher ozone dose is required to reach an 80% reduction in the total pharmaceutical concentration.</p> <p>Filamentous bulking sludge that upsets the clarifying process still constitutes a problem at many activated sludge plants. Ozone added to the return activated sludge has alleviated the problem, but it has not been applied in many trials. The other aim of this thesis was to investigate how ozone addition impacts settling qualities and filamentous bacteria when applied to the return activated sludge. Ozone was tested at two different WWTPs using similar equipment. At Öresundsverket, the specific ozone dosage ranged from 2.8 to 5.0 g O₃/kg SS with a constant ozone dosage rate of 900 g O₃/h. At Klagshamn WWTP, the specific ozone dose was more variable because the flow of return activated sludge was changed to investigate how it impacted the results.</p> <p>The addition of ozone to the return activated sludge lowered the sludge volume index (SVI) and diluted sludge volume index (DSVI) significantly at both locations. The SVI in the first Klagshamn trial was decreased from approximately 200 mL/g to below 100 mL/g, and the SVI was reduced from 170 mL/g to 100 mL/g in the trial at Öresundsverket WWTP. The biological nutrient removal processes were not affected by the ozone process. A second full-scale trial at Klagshamn WWTP further demonstrated that ozone significantly improves the settling qualities of activated sludge. The DSVI was decreased from 82 mL/g to 54 mL/g with 4.0 g O₃/kg TSS. Live/Dead® analysis of the ozonated sludge from that trial revealed that filamentous bacteria protruding outside the flocs are significantly more affected by ozone than bacteria within the flocs. In addition, ozone doses that are applicable to filamentous bulking control will not result in higher methane production from anaerobic digestion or be sufficient to oxidize micro-pollutants in the sludge.</p>		
Key words: Ozone, Filamentous Sludge, Pharmaceuticals, Wastewater Treatment		
Classification system and/or index terms (if any)		
Supplementary bibliographical information	Language: English	
ISSN and key title	ISBN 978-91-7753-521-8 (print) ISBN 978-91-7753-522-5 (pdf)	
Recipient's notes	Number of pages: 113	Price
	Security classification	

I, the undersigned, being the copyright owner of the abstract of the above-mentioned dissertation, hereby grant to all reference sources permission to publish and disseminate the abstract of the above-mentioned dissertation.

Signature



Date 2017-11-27

Application of ozone in wastewater treatment

Oxidation of pharmaceuticals and filamentous bulking
sludge

Filip Nilsson



LUND
UNIVERSITY

Cover photo by Jan Borgström

Copyright 2017 Filip Nilsson. All Rights Reserved.

Water and Environmental Engineering
Department of Chemical Engineering
Lund University

ISBN 978-91-7753-521-8 (print)

ISBN 978-91-7753-522-5 (pdf)

Printed in Sweden by Media-Tryck, Lund University
Lund 2017



Preface

During the course of my Ph.D. studies I primarily investigated how to use ozone in two wastewater applications.

For the first application, mitigation of filamentous bulking sludge problems, I conducted full-scale trials in 2011 with ozone at Klagshamn WWTP in Malmö and at Öresundsverket WWTP in Helsingborg. The objectives of these studies were to study how effective ozone would be in improving the settling qualities of activated sludge. In 2016, I conducted another full-scale trial with ozone at Klagshamn WWTP. The main objective was to study how ozone affects filamentous bacteria. A secondary objective of that study was to investigate whether this ozone application could result in any positive side-effects such as increased methane production and micro-pollutant removal.

For the second application, I took part in two pilot-scale studies aimed at oxidizing pharmaceuticals in wastewater effluent with ozone. The first pilot-scale study I conducted together with Janne Väänänen at Lundåkraverket WWTP in Landskrona. The second study took place at 10 different WWTPs in southern Sweden.

Since my licentiate thesis in 2015 (Nilsson, 2015) I have mainly focused on oxidation of pharmaceuticals with ozone. The filamentous sludge section of this doctoral thesis is therefore similar to that thesis.

Acknowledgement

I express my heartfelt gratitude to Karin Jönsson and Åsa Davidsson for accepting me as a Ph.D. student and for your endless support and friendship.

I also thank Primozone Production AB for financing my studies.

I wish to thank Svenskt Vatten for their financial support via VA-teknik Södra.

I wish to thank ÅForsk and the J. Gust. Richert foundation for their financial support for Paper V.

I am also very thankful for the work by the staff at NSVA and VA SYD for their efforts during the trials with ozone at Klagshamn, Öresundsverket and Lundåkraverket WWTPs for Papers I, II, III and V.

I also wish to thank the personnel at the following WWTPs for their help in the trials for Paper IV: Sternö, Sjöhög, Nyvångsverket, Torekov, Sjölunda, Källby, Ellinge, Kävlinge, Svedala and Västra Stranden.

I wish to express my gratitude to the following individuals:

Gertrud Persson for your work, support and patience during our laboratory work, also for being my friend.

Ivelina Dimitrova for your work on the full-scale ozonation at Klagshamn and publication of Paper I and Paper V.

Janne Väänänen for our full-scale experiments for Paper III and your great support.

Marinette Hagman for your work and input with Paper II and III.

Jes la Cour Jansen for our discussions and your work on Papers III and IV.

Maritha Hörsing for your work on Paper III.

Per Halkjær Nielsen and Artur Tomasz Mielczarek for your work on Paper II.

Maja Ekblad for your work on Paper IV.

Per Falås and Simon Bengtsson for your work on Paper V.

Michael Cimbritz for your input on pharmaceuticals in this thesis.

Robert Sehlén for your input for this thesis.

My family and friends for their love and support.

Abstract

As pharmaceutical removal was not part of the of the modern wastewater treatment plant (WWTP) design, it is not surprising that WWTPs have been identified as major point sources of pharmaceuticals entering the environment. The oxidation of pharmaceuticals in the WWTP effluent is one of the end-of-pipe solutions that are considered most ready for full-scale use. However, there are several aspects of its application that must be further researched. One aim of this thesis project was to investigate how effective ozone is when applied to different WWTPs. When ozone was applied to the effluent of Lundåkraverket WWTP, the importance of the organic carbon content was highlighted. A pre-treatment that removed most of the organic carbon (suspended solids) removed 95% of the total pharmaceutical concentration with an ozone dose of five g O₃/m³. Without this pre-treatment, the removal reached 80% with the same ozone dose. Moreover, the impact of TOC was substantial when ozone was applied in the same manner at ten different WWTPs; as the TOC content in the wastewater effluent increases, a higher ozone dose is required to reach an 80% reduction in the total pharmaceutical concentration.

Filamentous bulking sludge that upsets the clarifying process still constitutes a problem at many activated sludge plants. Ozone added to the return activated sludge has alleviated the problem, but it has not been applied in many trials. The other aim of this thesis was to investigate how ozone addition impacts settling qualities and filamentous bacteria when applied to the return activated sludge. Ozone was tested at two different WWTPs using similar equipment. At Öresundsverket, the specific ozone dosage ranged from 2.8 to 5.0 g O₃/kg SS with a constant ozone dosage rate of 900 g O₃/h. At Klagshamn WWTP, the specific ozone dose was more variable because the flow of return activated sludge was changed to investigate how it impacted the results. The addition of ozone to the return activated sludge lowered the sludge volume index (SVI) and diluted sludge volume index (DSVI) significantly at both locations. The SVI in the first Klagshamn trial was decreased from approximately 200 mL/g to below 100 mL/g, and the SVI was reduced from 170 mL/g to 100 mL/g in the trial at Öresundsverket WWTP. The biological nutrient removal processes were not affected by the ozone process. A second full-scale trial at Klagshamn WWTP further demonstrated that ozone significantly improves the settling qualities of activated sludge. The DSVI was decreased from 82 mL/g to 54 mL/g with 4.0 g O₃/kg TSS. Live/Dead[®] analysis of the ozonated sludge from that trial revealed that filamentous bacteria protruding outside the flocs are significantly more affected by ozone than bacteria within the flocs. In addition, ozone doses that are applicable to filamentous bulking control will not result in higher methane production from anaerobic digestion or be sufficient to oxidize micro-pollutants in the sludge.

Populärvetenskaplig sammanfattning

Avloppsreningsverk är en viktig del av samhället även om de flesta aldrig ägnar en tanke på hur avloppsvattnet renas. Under slutet av 60-talet i Sverige började problemen med övergödning att få stor uppmärksamhet och den svenska regeringen beslutade att något måste göras. En storskalig utbyggnad och modernisering av avloppsreningsverken drogs igång under 70-talet och positiva effekter på vattendragen kunde ses inom några år. I dag står vi inför ett nytt problem. Läkemedel som vi tar i hemmet tar sig via avloppet till avloppsreningsverken och passerar i många fall rakt igenom. Långtidseffekterna av att läkemedel finns närvarande i vattendrag är i dagsläget inte kända men det har påvisats att fiskar får problem med fortplantningen på grund av hormoner från p-piller. Forskning har visat att det går att minska halterna av läkemedel som släpps ut från verken. De två tekniker som har kommit längst är tillsättning av aktivt kol eller ozon till utloppet av reguljärt behandlat avloppsvatten. Då ozon inte har använts i denna applikation i mer än några år finns det fortfarande stora kunskapsluckor. Till denna avhandling genomfördes flertalet försök i pilot-skala för att undersöka huruvida ozon kan användas överallt med samma resultat samt hur ozonbehandlingen påverkas av halten organiskt kol. Resultaten visar att ozonbehandlingen inte blir lika effektiv överallt. En dosering som fungerar bra på ett verk ger inte nödvändigtvis samma resultat på ett annat verk. Detta verkar till stor del bero på halten av organiskt kol i avloppsvattnet.

Ett annat problem i dagens avloppsreningsverk är uppkomsten av slam som är svårt att avskilja genom sedimentering. Sedimentation är ett kritiskt processteg inom avloppsvattenrening. Ett slam som inte sedimenterar ordentligt kan leda till otillåtna utsläpp av näringsämnen och andra problem med driften av verket. En orsak till att slam blir svårt att sedimentera är ohindrad tillväxt av så kallade filamentbakterier. Dessa bakterier skapar långa nätverk som ökar ytan på slammet vilket i sin tur gör att det sedimenterar alldeles för långsamt. För att åtgärda detta problem kan man tillsätta olika kemikalier, bland annat ozon. I den här avhandlingen har appliceringen av ozon testats i fullskala och visat sig öka sedimentationshastigheten på slam inom ca två till sex veckor. De nödvändiga biologiska processerna på verken blev inte negativt påverkade av en sådan behandling.

List of papers

- Paper I** Nilsson, F., Jönsson, K. and Dimitrova, I. 2012. Full-scale ozonation to reduce filamentous sludge at Klagshamn WWTP. Proceedings of the International Ozone Association conference, Toulouse, June 4-6.
ISBN 978-2-9528298-9-2.
- Paper II** Nilsson, F., Hagman, M., Mielczarek, A. T., Nielsen, P. H. and Jönsson, K. 2014. Application of ozone in full-scale to reduce filamentous bulking sludge at Öresundsverket WWTP. *Ozone Science & Engineering* 36 (3): 238-243.
- Paper III** Väänänen, J., Nilsson, F., la Cour Jansen, J., Hörsing, M., Hagman, M. and Jönsson, K. 2014. Discfiltration and ozonation for reduction of nutrients and organic micro-pollutants from wastewater – a pilot study. *Water Practice & Technology* 9 (4): 475-482.
- Paper IV** Nilsson, F., Ekblad, M., la Cour Jansen, J., Jönsson, K. 2017. Removal of pharmaceuticals with ozone at 10 Swedish wastewater treatment plants. *Water Practice & Technology* (accepted for publication).
- Paper V** Nilsson, F., Davidsson, Å., Falås, P., Bengtsson, S., Bester, K. and Jönsson, K. 2017. Impact of ozonation on filamentous bacteria viability and possible added benefits. (submitted for publication)

Other publications

Punzi, M., Nilsson, F., Anbalagan, A., Svensson, B.-M., Jönsson, K., Mattiasson, B. and Jonstrup, M. 2015. Combined anaerobic-ozonation process for treatment of textile wastewater: removal of acute toxicity and mutagenicity. *Journal of Hazardous Materials* 292: 52-60.

El-taliawy, H., Ekblad, M., Nilsson, F., Hagman, M., Paxeus, N., Jönsson, K., Cimbritz, M., la Cour Jansen, J. and Bester, K. 2017. Ozonation efficiency in removing organic micro pollutants from wastewater with respect to hydraulic loading rates and different wastewaters. *Chemical Engineering Journal* 325: 310-321.

Haghighatafshar, S., Nilsson, F., Väänänen, J., Hagman, M., Hey, G., Bollmann, U. E., Bester, K. and Jönsson, K. 2017. Application of microsieving with O₃ or ClO₂ for treatment and disinfection of combined sewer overflows. (submitted for publication).

My contributions to the papers

Paper I I wrote the article, helped with the experimental equipment and created the figures. The experiments were designed and conducted by Ivelina Dimitrova and the article is based on her Master of Science thesis from 2011.

Paper II I planned the experiment together with Karin Jönsson and Marinette Hagman. I conducted the ozone experiments, evaluated the experimental data and wrote the article.

Paper III I planned the experiments together with Janne Väänänen and Jes la Cour Jansen. I evaluated the ozone experimental data and wrote the ozone parts of the article.

Paper IV I planned the ozone experiments together with Jes la Cour Jansen. I conducted the ozone experiments and wrote the article.

Paper V I planned the ozone experiments together with Karin Jönsson, Åsa Davidsson, Per Falås, Simon Bengtsson and Ivelina Dimitrova. I conducted the ozone experiments together with Per Falås and I wrote the article together with Simon Bengtsson, Per Falås, Åsa Davidsson and Kai Bester.

Abbreviations

Abbreviation	Explanation	Abbreviation	Explanation
A	Area	k_{O_3}	Second order reaction rate constant with ozone
AWWA	American Water Works Association	MP(s)	Micro-pollutant(s)
Bar(g)	Relative pressure, bar gauge	N_A	Mass transfer rate
Bio-P	Biological Phosphorus Process	NDMA	N-Nitrosodimethylamine
BOD	Biological Oxygen Demand	NH_4-N	Ammonium nitrogen
c_G	Concentration in gas bulk	P	Pressure
$c_{G,i}$	Concentration in gas interface	PAC	Powdered Activated Carbon
c_L	Concentration in liquid bulk	PACl	Poly Aluminium Chloride
$c_{L,i}$	Concentration in liquid interface	p-CBA	para-Chlorobenzoic Acid
c_L^*	Equilibrium concentration	p.e.	Population Equivalent
COD	Chemical Oxygen Demand	PFR	Plug Flow Reactor
CSTR	Continuously Stirred Tank Reactor	RAS	Return Activated Sludge
DOC	Dissolved Organic Carbon	R_{CT}	Ratio of ozone to hydroxyl radicals
DSV	Dilluted Sludge Volume	SVI	Sludge Volume Index
DSVI	Diluted Sludge Volume Index	Swedish EPA	Swedish Environmental Protection Agency (Naturvårdsverket)
EDC	Endocrine Disruptive Compound	TOC	Total Organic Carbon
GAC	Granulated Activated Carbon	USEPA	United States Environmental Protection Agency
HRT	Hydraulic Retention Time	V	Volume
k_G	Mass transfer coefficient in the gas bulk	V_L	Volume of liquid
k_L	Mass transfer coefficient in the liquid bulk	VSS	Volatile Suspended Solids
$k_{L,A}$	Volumetric mass transfer coefficient	WWTP	Wastewater Treatment Plant

Content

1	Introduction	1
1.1	Research questions	2
2	Materials and methods	3
2.1	Full-scale installations for filamentous bulking sludge mitigation.....	3
2.2	Pilot-scale installations for the oxidation of pharmaceuticals	6
3	Ozone	9
3.1	Applications of ozone.....	9
3.2	Ozone addition.....	10
3.2.1	Venturi injection	10
3.2.2	Static mixer.....	12
3.2.3	Bubble column.....	13
3.2.4	Advantages and disadvantages of the different systems.....	14
4	The biological nutrient removal activated sludge plant	19
5	Ozone and pharmaceuticals in wastewater.....	21
5.1	Factors influencing pharmaceutical oxidation with ozone	23
5.1.1	Ozone dose and the impact of the water matrix	23
5.1.2	Aspects of the water matrix	23
5.1.3	Ozone kinetics	26
5.1.4	Evaluating ozone doses	27
5.1.5	Predicting pharmaceutical removal	31
5.1.6	Unintended by-product formation	34
5.2	Ozone addition in practice	36
5.2.1	Hydraulic retention time	36
5.2.2	Dose control.....	38
5.2.3	Cost.....	40

6	Ozone and filamentous bulking sludge	41
6.1	Reducing filamentous sludge bulking with ozone.....	43
6.2	Impact on SVI and DSVI.....	44
6.2.1	Impact on biological nutrient removal.....	49
7	Conclusions	53
7.1	Ozone and pharmaceuticals	53
7.2	Ozone and filamentous bulking sludge	54
8	Future studies	55
9	References	57

1 Introduction

The efficient treatment of wastewater is important for protecting the environment. Prior to the implementation of modern wastewater treatment, sewage was simply discharged untreated into lakes and rivers. By the 1960s, Swedish waters had become eutrophicated to the extent that lakes were overgrown and algae blooms were frequent. The problem was large enough for the Swedish government to initiate a massive buildup of wastewater treatment plants (WWTPs) throughout the 1970s, and all households in urban areas are now connected to a WWTP (Swedish EPA, 2016). This situation is the same in the industrialized world, with most homes connected to a central WWTP (UN, 2011). The impact of wastewater treatment on eutrophication is significant; within a few years of constructing the WWTPs in Sweden, the quality of surface water was greatly improved (Swedish EPA, 2016).

The most common WWTP process that is currently used Sweden, biological and chemical nutrient removal, was designed to limit the discharge of chemical oxygen demand (COD), biological oxygen demand (BOD), and nutrients into the environment (Swedish EPA, 2016). As WWTPs were not designed to handle pharmaceuticals and other micro-pollutants, it is not surprising that WWTPs have recently been identified as a major point source of pharmaceuticals in rivers and lakes (Huerta-Fontela *et al.*, 2011). Although a portion of the pharmaceuticals entering the plant are removed by the existing processes, many compounds end up in the environment (Ternes, 1998). The total effect of pharmaceuticals in the environment is unknown, but hormones from contraceptive pills have caused endocrine disruption in fish populations (Jobling *et al.*, 1996 & 1998; Sumpter, 1995; Ternes *et al.*, 2004). The fact that pharmaceuticals are entering the environment from WWTPs indicates that the current systems of wastewater treatment are insufficient. There have been advancements within this field and the oxidation of pharmaceuticals by ozone has been identified as a promising technology for addressing this problem. Since the use of ozone in this application is relatively new, there are areas which are not entirely understood such as dosing control and the effectiveness of ozone at any WWTP.

Another problem with modern WWTPs using activated sludge is filamentous bulking. This is a phenomenon caused by long filamentous bacteria growing to such an extent that they cause the sludge to settle slowly in the gravitational settler. The settler must be placed close to the final steps in the process and is tailored to a

specific flow of sludge entering it. If the settler is hindered in its operation by the emergence of a slow-settling sludge (filamentous sludge), the throughput of the settler and the plant will be affected. Floating sludge in the settler is another consequence of filamentous sludge, leading to washing out of sludge and in turn excess nutrient and BOD discharge. This problem of slow-settling sludge can be alleviated, by adding chemicals (ozone or PAC) or changing process parameters to make other non-filamentous bacteria more dominant (van Leeuwen, 1988). The use of ozone in this application has been known for since the 1980s, but this method is not widely employed. Therefore, there are numerous aspects of this process that have not been investigated in detail, such as the mechanism of ozone attack on filamentous bacteria.

1.1 Research questions

The aim of this thesis study was to investigate how ozone can be utilized to improve wastewater treatment. Two applications of ozone were studied: oxidation of pharmaceuticals with ozone and mitigation of filamentous bulking sludge. The research questions for the two applications are as follows:

Will ozone be equally effective at oxidizing pharmaceuticals at any WWTP?

What influence will organic carbon have on the effectiveness of pharmaceutical oxidation with ozone and should organic carbon be removed before ozone addition?

Can ozone be applied at full scale to reach acceptable SVI levels, and how long does this take?

Does subjecting the flow of return sludge to ozone have a significant impact on the timeframe and effect of ozone?

Does ozone injection at the rate needed to reach acceptable SVI levels affect the critical biological processes of WWTPs negatively?

Will the addition of ozone change the microbiological composition of the sludge in the main activated sludge treatment line, and can any additional benefits be expected from the process?

2 Materials and methods

All ozone experiments for this thesis were conducted in pilot or full-scale tests at WWTPs. The general aims and experimental setups that were used are described below, and the analyses and experimental procedures are detailed in the papers in question (Paper I to Paper V).

2.1 Full-scale installations for filamentous bulking sludge mitigation

To study how ozone can mitigate problems related to filamentous bulking sludge, two identical full-scale systems for ozone addition were constructed and installed at Klagshamn (Paper I) and Öresundsverket (Paper II) WWTPs. The two systems were housed within ten ft containers, and they consisted of an ozone generator, oxygen production, compressor, ozone concentration measurement, and a main PLC for controlling the systems (Figure 1 and Figure 2). The system installed at Klagshamn WWTP was used in Papers I and V, while the ozone installation at Öresundsverket WWTP was used in Paper II.



Figure 1
Outside view of the container and pressurized reactor installed at Klagshamn WWTP.



Figure 2
Inside view of the same container. Visible from the left - main PLC, ozone generator, and oxygen generator.

At Klagshamn WWTP (Paper I), the container was installed such that it could treat both treatment lines (Figure 3) consecutively. A centrifugal pump was installed at a location in the process train to permit pumping of return sludge from one line (25-32 m³/h, ~5% of the total return sludge flow) through the Venturi injector and into the 7.9 m³ pressurized reaction chamber. Furthermore, the ozone treatment was switched between the two lines with the opening and closing of baffles and valves (Figure 3). The second trial at Klagshamn (Paper V) applied ozone to one treatment line.

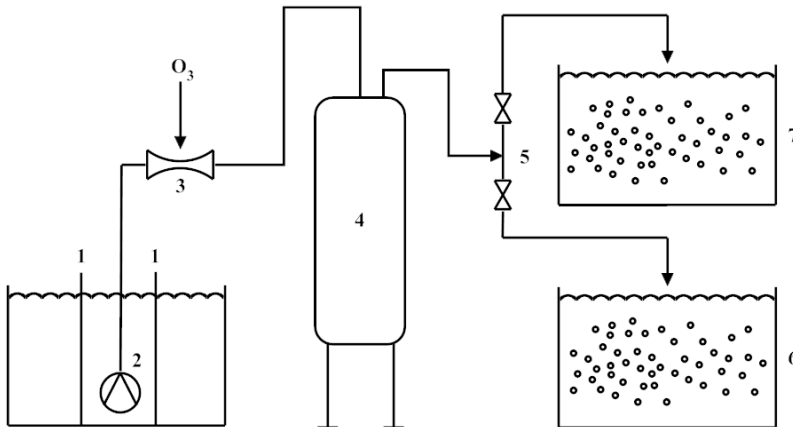

Figure 3
Simplified schematic overview of the experimental setup at Klagshamn WWTP (more details are available in Paper I).
1: Baffles for choosing source of RAS, 2: submerged centrifugal pump, 3: venturi injector, 4: pressurized reaction vessel, 5: valves for choosing destination of treated RAS, 6: aerated zone of treatment line 1, 7: aerated zone of treatment line 2.

At Öresundsverket WWTP (Figure 4 and Figure 5; Paper II), the equipment was installed to treat one line only. The centrifugal pump was installed in the return sludge basin and delivered ~42 m³/h (~5% of the total return sludge flow) to the Venturi injector and further into the pressurized reaction vessel (7.9 m³). From the reaction chamber, the ozone-treated return sludge was fed back into the aerobic basin.



Figure 4
Picture of the container and pressurized reaction vessel installed at Öresundsverket WWTP.

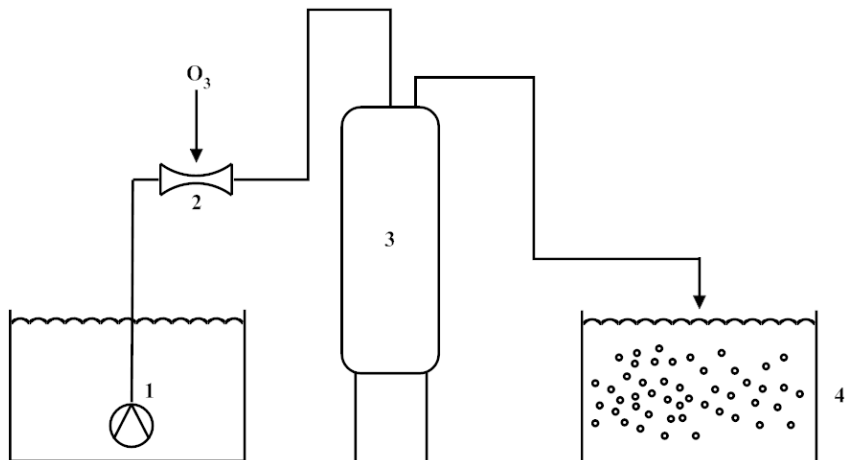

Figure 5
A simplified schematic of the ozonation system at Öresundsverket WWTP (more details are available in Paper II).
1: Submerged centrifugal pump, 2: venturi injector, 3: pressurized reaction vessel, 4: aerated zone of the chosen treatment line.

2.2 Pilot-scale installations for the oxidation of pharmaceuticals

Two different pilot-scale installations were used to investigate oxidation of pharmaceuticals in biologically treated wastewater for this thesis. The first was installed at Lundåkraverket WWTP (Paper III) and the second was used at ten different WWTPs (Paper IV). The pilot installation used in Paper III is depicted in Figure 6. The main feature of the pilot unit was that the order of the treatments could be switched such that ozone addition occurred either before or after the coagulation, flocculation, and disc filtration. The pilot was operated with a wastewater flow of 9.3-10 m³/h and a hydraulic retention time (HRT) of 5.4 to 5.8 minutes in the coagulation and flocculation stage, where four g of Al³⁺/m³ was added before 1.5 g/m³ of high molecular weight and medium-high charge cationic powder polymer was added. After coagulation and flocculation, the water entered a disc filter with ten µm pores. Either after or before the coagulation, flocculation, and disc filtration step, the wastewater was subjected to two, five, and nine g O₃/m³ in a pressurized reaction vessel with an HRT of 2.6 minutes (for more details see Paper III).

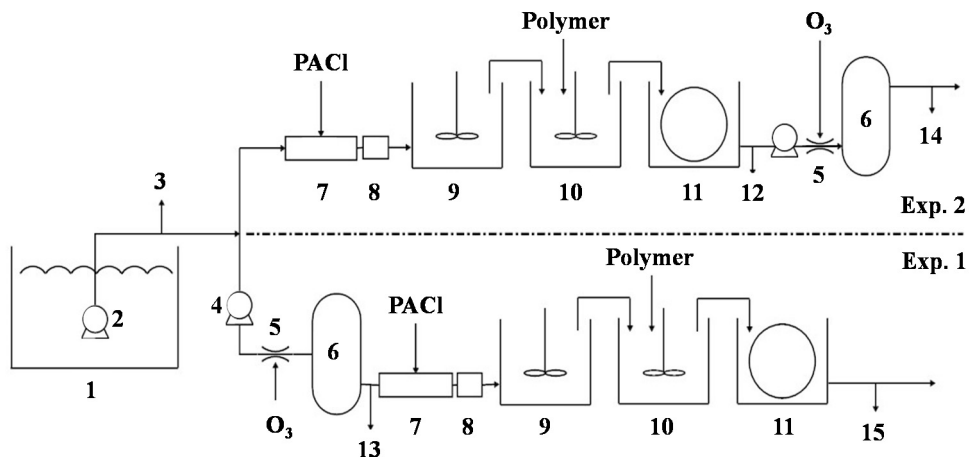

Figure 6

Schematic of the pilot-scale installation used in Paper III. 1: Effluent from the secondary sedimentation basins, 2: Submerged centrifugal pump, 3: Influent to the pilot plant sampling point, 4: Booster pump, 5: Venturi-type ozone injector, 6: Pressurized reaction tank, 7: Static mixer, 8: Flow meter, 9: Stirred PAC reaction tank, 10: Stirred polymer reaction tank, 11: Discfilter, 12: Post-discfiltration sampling point, 13: Post-ozonation sampling point, 14: Post-ozonation sampling point, 15: Post discfiltration sampling point.

The pilot-scale system used in Paper IV (Figure 7) consisted of a 20ft container which housed all necessary equipment including but not limited to the ozone generator, oxygen production, compressor, ozone concentration measurement, flow measurement, and a pressurized reaction vessel (HRT 5 min). The system operated in the same way at all ten WWTPs (details are available in Paper IV). In summary, wastewater was pumped through the system and the first ozone dose ($3 \text{ g O}_3/\text{m}^3$) was applied. After 20 minutes, the first sample was taken and repeated every ten minutes for one hour. The next ozone dose was then applied ($5 \text{ g O}_3/\text{m}^3$) and the sampling was repeated until the last ozone dose ($7 \text{ g O}_3/\text{m}^3$) was finished.

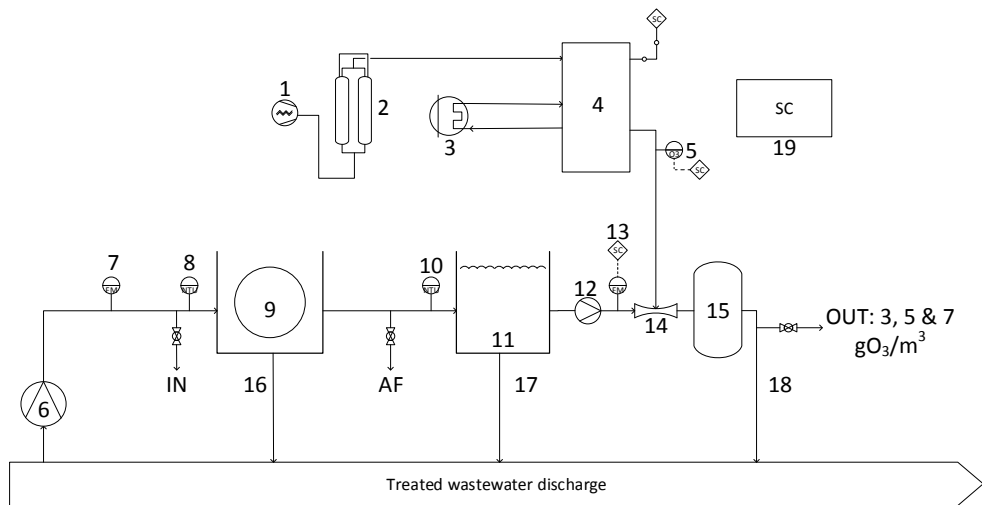

Figure 7

Schematic of the pilot scale installation used in Paper IV. 1: Compressor, 2: PSA oxygen supply, 3: Chiller, 4: Ozone generator, 5: Ozone concentration meter, 6: Submerged centrifugal pump, 7: Flowmeter, 8: Turbidity meter, 9: Drum filter, 10: Turbidity meter, 11: 1 m^3 equalization tank, 12: Booster pump, 13: Flow meter, 14: Venturi injector, 15: 500 l pressurized reaction vessel (HRT: 5 min), 16: Sludge from drum filter, 17: Excess flow, 18: Discharge from ozonation, 19: Main PLC. Details available in Paper IV.

3 Ozone

Ozone has one property that makes it useful in wastewater treatment: its high oxidation potential (2.07 V). Oxidation is a chemical reaction in which substances release one or more electrons and become positively charged (oxidized). The released electrons are then accepted by another molecule which in turn becomes reduced. The oxidation potential value denotes a compound's readiness to undergo such reactions. The high reactivity of ozone is derived from its inherent instability due to the molecule's readiness to accept an electron; reducing ozone to O₂, the electron donor becomes oxidized.

Ozone was first reported and named by Carl Friedrich Schönbein in 1840 before the French academy of science. The name comes from the Greek word ozein, "to smell", which is fitting since the smell of ozone is highly characteristic. A high degree of effort went into discerning the true nature of ozone by researchers such as C. F. Schönbein, J. L. Soret, J. C. G. de Marignac, R. F. Marchand, J. J. Berzelius, A. C. Becquerel, and J. A. Houzeau, L. von Babo. It was discovered that ozone was an allotrope of oxygen in 1865 by J. L. Soret and he confirmed this in 1867. The high reactivity of ozone was noted by Schönbein in his early experiments (Rubin, 2001), necessitating a careful choice of materials in which to house the ozone.

3.1 Applications of ozone

The first major application of ozone was disinfecting potable water. The first ozone installation for this application was a pilot plant installed in Martinikenfelde in 1891 with equipment from Siemens and Halske in the German Empire. A full-scale installation of ozone to treat drinking water followed in 1893 in Oudshoorn, Netherlands. Afterwards, the number of ozone plants in Europe and America continued to rise until 1915, when 49 installations were completed in Europe. The wartime research into poisonous gases for the battlefields in Europe and Russia during World War I however, gave rise to inexpensive chlorine. Chlorine then superseded ozone as the major disinfection agent, primarily due to its low price and relative ease of use.

The construction of new ozone plants did not reach the same level as before 1915 until after World War II (AWWA, 1991). It has since been realized that ozone can be utilized for applications other than disinfecting drinking water, such as iron and manganese removal, color removal, protecting food from microbiological attack, turbidity reduction, pesticides degradation, SVI reduction of sludge, excess sludge minimization, disinfection of wastewater, and increased methane production from sludge (Bougrier *et al.*, 2006; Böhler & Siegrist, 2004; Camel & Bermond, 1998; Kim *et al.*, 1999; van Leeuwen & Pretorius, 1988; Xu *et al.*, 2002;). The use of ozone to remove micro-pollutants such as pharmaceuticals, biocides, and endocrine disruptive compounds (EDCs) has recently gained attention. This growing interest in removing pharmaceuticals is highlighted by the Swiss decision to implement legislation, which compelled certain WWTPs (criteria in section 5.1) to install additional treatment steps to reduce the concentration of pharmaceuticals in their discharge (Eggen *et al.*, 2014).

3.2 Ozone addition

Since ozone is produced as a gas, it must be transferred into the water phase to react, and a dissolution system is needed to perform this transfer. The most commonly used ozone transfer systems are introduced in this section.

3.2.1 Venturi injection

The Venturi injector works on the principle of the Venturi effect, which is named after the Italian physicist Giovanni Battista Venturi and described in his 1799 work “Experimental Inquiries Concerning the Principle of the Lateral Communication of a Motion in Fluids” (Venturi, 1826). Water enters the Venturi and a decrease in cross-sectional area rapidly increases the linear velocity of the water. This increase in velocity creates suction at an orifice into which ozone can be injected. When ozone is injected, an emulsion of fine ozone bubbles and water is created, and the cross-sectional area is increased to the original area (Bin & Roustan, 2000). A representation of how a Venturi injector functions is depicted in Figure 8.

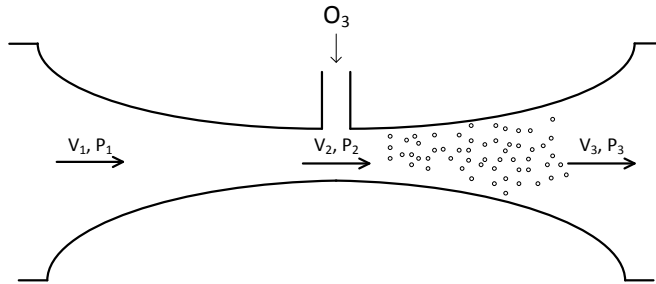

Figure 8
A principal representation of a venturi injector.

The velocity (V) undergoes a drastic increase from points 1-2, leading to a rapid decrease in pressure (P). The velocity then decreases, and the pressure rises again due to the increase in diameter (point 3). A Venturi injector installed at a full-scale potable water plant in the US is depicted in Figure 9.



Figure 9
A venturi injector installed at a potable water plant in the US. The water flows upwards and ozone is injected in the port on the right hand side. Photo by Mats Cato (reproduced with permission).

3.2.2 Static mixer

A static mixer is a relatively simple device with no moving parts; the liquid (e.g. biologically treated wastewater) is propelled through the mixer unit and mixed with the gas. It consists of several static mixing elements (Figure 10) which are designed to shear and disperse a liquid or mixture of liquid and gas radially in a pipe or duct (Heyouni *et al.*, 2002; Martin *et al.*, 1994).

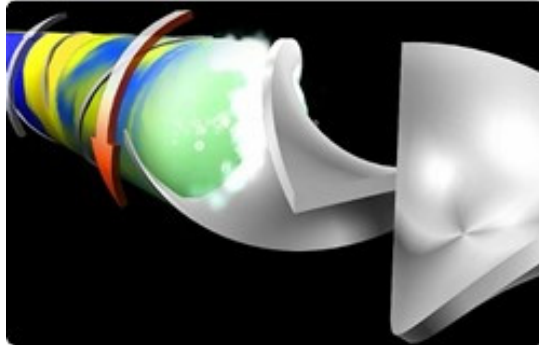

Figure 10
Static mixing elements of a mixer (grey). Arrows indicate the direction of water flow. Image by PAOR CO., Ltd. (reproduced with permission).

Ozone can be introduced to the mixer either directly as pressurized gas or as an emulsion created by a Venturi. The mixing elements are designed such that a typical pressure loss through the mixer is in the range of 0.05 to 0.3 bars per meter of the mixer (Bin & Roustan, 2000). In Figure 11, a pair of full-scale static mixers are installed in the main flow pipes of a water treatment plant.



Figure 11
A full-scale installation of static mixers in the main flow pipes in a potable water plant in South Korea. Photo by PAOR CO., Ltd. (reproduced with permission).

3.2.3 Bubble column

Bubble columns are the most widely used system for transferring ozone into water. The reason for their popularity in industrial and municipal applications is that there is no need to pressurize the water. The diffuser (Figure 12) consists of a porous ceramic material which disperses the gaseous ozone into bubbles approximately two to three mm in diameter (Bin & Roustan, 2000).



Figure 12
Typical ceramic diffusers for ozone. The darker part of the left diffuser is the porous ceramic material dispersing the gas, and the diffuser on the right is overturned to show the connection point of ozone (middle threaded connection).

The bubble diffusers are placed at the bottom of a contact tank (Figure 13); pressurized ozone (0.7 – 2 bars, g) flows through the diffusers (arrows indicates water flow direction) and is dispersed as bubbles, which meet the water as it flows counter-currently toward them. Depending on the application, baffles can be employed to facilitate a plug flow regime. A large bubble column installed in South Korea is depicted in Figure 14.

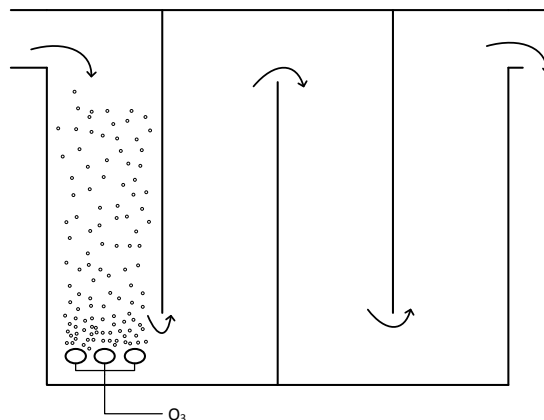

Figure 13
A schematic representation of a bubble column with baffles. Water enters the column and flows (arrows) counter-currently toward the ozone bubbles.



Figure 14
Picture of a bubble column installation in South Korea. Photo by PAOR CO., Ltd. (reproduced with permission).

3.2.4 Advantages and disadvantages of the different systems

When ozone has meets the water and forms bubbles, it must be transferred from the bubbles into the bulk of the liquid. This transfer of mass from the gas phase to the liquid phase has been extensively researched and several mathematical models exist. These models are not described in detail here, but for readers interested in mass-transfer models and their applications in chemical engineering, the book by Coulson *et al.* (1999) is recommended. The simplest model of mass-transfer, the two-film theory, describes the transfer rate of a solute from a gas bubble into a liquid through a laminar interface (Figure 15). As shown in Equation 1, the mass-transfer rate (N_A) is governed by the mass-transfer coefficients in the gas film (k_G), liquid film coefficient (k_L), interface area (A), concentrations in the gas and liquid bulk (C_G and C_L), and concentrations at the gas and liquid interface ($C_{G,i}$ and $C_{L,i}$).

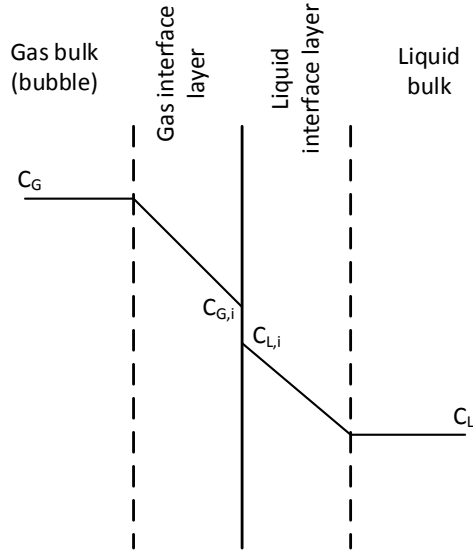

Figure 15
The two film model of mass transfer.

Equation 1

$$N_A = k_G A (C_G - C_{G,i}) = k_L A (C_{L,i} - C_L)$$

From Equation 1, a more practical method of estimating the mass-transfer rate can be expressed (Equation 2), in which the mass-transfer coefficient is combined with the interface area and liquid volume in the volumetric mass-transfer coefficient ($k_{L,a}$) (Bin & Roustan 2000). The mass-transfer rate (N_A) is then dependent on the equilibrium concentration in the liquid (C_L^*), concentration distribution in the liquid (C_L), and liquid volume (V_L)

Equation 2

$$N_A = k_{L,a} \cdot (C_L^* - C_L) \cdot V_L$$

To compare the three different ozone transfer systems, ranges of experimental values (Bin & Roustan, 2000) for the volumetric mass-transfer coefficient (oxygen transfer) are displayed in Table 1.

Table 1Ranges of experimental values for $k_{L,a}$ (Bin & Roustan, 2000).

Ozone transfer device	$k_{L,a}$ (/s)
Venturi injector	0.1-10
Static mixer	0.1-10
Bubble column	0.0001-0.1

As presented in Table 1, the Venturi and static mixer transfer systems are superior to the bubble column in terms of the volumetric transfer coefficient. However, there are many complicating factors. A Venturi injector needs a high pressure-gradient to function properly; a higher pressure drop is required as the injected gas flow increases. Thus, a pump is needed to increase the pressure to a sufficient level called a booster pump. If ozone is injected into a high flow (such as in a WWTP), the combination of high flow and required pressure makes it impractical to use the Venturi in the main flow. A side-stream with a fraction of the main flow constitutes a more practical solution, since the pump only needs to increase the pressure by hundreds of cubic meters rather than several bars with thousands of cubic meters per hour.

An example of a Venturi side-stream is depicted in Figure 16. A booster pump (1) draws water from the main line and increases the pressure to approximately three bars (g). Ozone is introduced at the suction part of the injector (3), and the pressure of the subsequent ozone and water mix is one bar (g). The pressure is typically monitored by pressure indicators (2 and 4). Furthermore, the ozone and water mix of the side-stream must then enter the main line flow. This can be done either by reintroducing it immediately (as shown) or running it in parallel to the main flow and connecting it to a contact chamber in which ozone and water can react further.

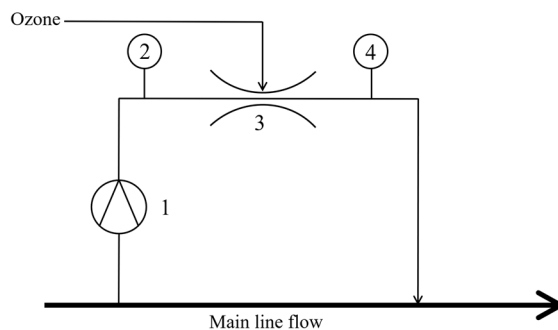

Figure 16
A schematic of how a venturi side stream can be configured. 1: booster pump, 2: pressure gauge, 3: venturi injector, 4: pressure gauge.

The static mixer does not require as much pressure as the Venturi; however, it does require the entire main flow to be pressurized as it is installed in the main line. Though the Venturi and static mixer systems for ozone addition have the highest volumetric transfer rates, the pressurization of the ozonated water adds significant energy in the form of pumping. Therefore, it is not surprising that the simplest form of ozone transfer, the bubble column, is the most widely used. However, the reaction kinetics governing the reactions between ozone and organic compounds is dependent on the concentration of ozone that is available to react (section 5.1.3). Since an inefficient ozone transfer system will result in a large portion of wasted ozone (not dissolved), additional ozone must be produced to achieve as much oxidation of organic compounds as more efficient dissolution systems. Increasing ozone production leads to higher installation and running costs. Therefore, it is advisable to properly weigh the running cost of the transfer system to the cost of producing additional ozone.

4 The biological nutrient removal activated sludge plant

A WWTP is an important part of everyday life, though most people do not think about it. A common treatment is a system called activated sludge. Activated sludge is a biological process in which bacteria converts BOD, COD, nitrogen, and phosphorus in wastewater into biomass, CO₂, and sometimes N₂. To retain the active bacteria in the process, a gravitational settler is usually employed. The extra biomass created by the bacteria is removed from the system by the gravitational settler.

The activated sludge system for the treatment of wastewater evolved after 1914 to the aeration of Imhoff tanks through blower tanks, the recycling of sludge, and the current system. Readers interested in the history of the activated sludge system should read the review of the subject by Alleman and Prakasam (1983). The current system of activated sludge treatment varies throughout the world depending on numerous factors such as geographical pre-requisites (e.g. effluent demands, land availability, and climate), and loading. However, their purpose is to remove BOD, COD, and nutrients to varying degrees, utilizing suspended bacteria and aeration. These plants require sufficient HRT, aeration and stirring, sludge separation, recycling, and disposal, which can be configured in many different ways. For example, the removal of phosphorus can be achieved by utilizing the suspended bacteria or chemical precipitation, or a combination of both. The removal of nitrogen is more uniformly designed with the use of nitrification and denitrification bacteria, which have operational requirements such as aeration, anoxic zones, and a carbon source. An example of a fully biological nutrient removal WWTP is presented in Figure 17.

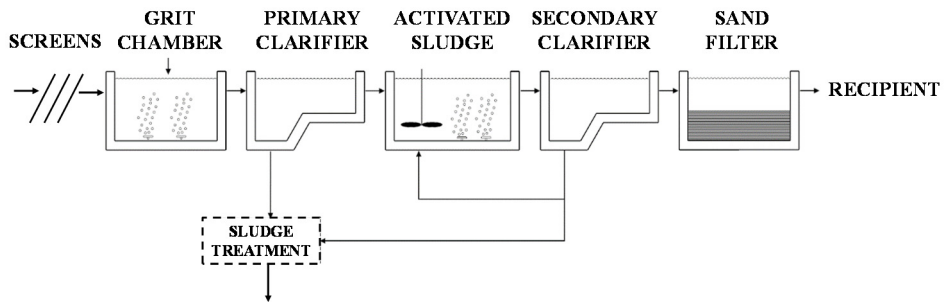

Figure 17
A schematic overview of a fully biological nutrient removal WWTP.

The first treatment step in Figure 17 consists of screens followed by an aerated grit chamber and then by primary clarification. The biological stage (which may include Bio-P) is often divided into zones which can be run as anaerobic and anoxic or aerobic and anoxic. The sludge separation is conducted with a secondary clarifier that recycles most of the sludge back into the anaerobic and anoxic zone. The excess sludge is pumped to the sludge treatment, consisting of thickening, dewatering, and sometimes anaerobic digestion. The final stage before the treated wastewater is released to the recipient consists of a sand filter.

Regardless of how these operations are set up, the underlining principles of operation remain the same for the challenges of utilizing bacteria. For instance, the secondary clarifier is highly susceptible to disturbances in the sludge's settling speed. Slow-settling sludge (which can be caused by filamentous bacteria) can affect the maximum throughput of the settler and since it is not advisable to bypass this stage, the throughput of the entire plant can be affected.

5 Ozone and pharmaceuticals in wastewater

The purpose of pharmaceuticals is to have therapeutic effects on organisms. The pharmaceutical compound interacts with target sites on or in cells due to its chemical structure and causes these therapeutic effects. For a compound to reach its intended target site at the appropriate time, it must retain its chemical structure in a biological system for a sufficient duration. This presents a problem when an active compound is expelled from the intended biological system and enters another one. A compound that is biologically active in one type of cell in an organism can also be active in another unintended organism. If a pharmaceutical compound is persistent in a biological system, it is resistant to biological treatment in WWTPs (Klavarioti *et al.*, 2009; Santos *et al.*, 2010). The long-term effect of pharmaceuticals being discharged into the environment on aquatic life is still not known, but endocrine disruption (by contraceptive pills) has been detected in fish by several researchers (Sumpster, 1995; Jobling *et al.*, 1996 & 1998; Länge *et al.*, 2001). A complicating factor of the effect of pharmaceuticals on the environment is that there is often a mix of active compounds present (Halling-Sorensen *et al.*, 1998). Many rivers and lakes are also used as sources for drinking water. Wastewater discharged into these recipients is the source of pharmaceuticals found before and after treatment in drinking water treatment plants (Huerta-Fontela *et al.*, 2011).

A survey of the effluent concentrations of pharmaceuticals from 49 German WWTPs (Ternes, 1998) showed that the existing WWTPs cannot sufficiently remove pharmaceuticals. Ternes (1998) screened for thirty-two substances, and metoprolol and carbamazepine were the most persistent throughout all WWTPs. The sampling was extended to include rivers downstream of the WWTPs, and 20 out of the 32 substances were found there as well with the highest concentrations in the $\mu\text{g/L}$ range. Furthermore, a survey by Falås *et al.* (2012) of the pharmaceutical concentrations in the influent and effluent of many WWTPs in Sweden revealed that atenolol, metoprolol, furosemide, and hydrochlorothiazide were discharged from most plants at a concentration of approximately one $\mu\text{g/L}$, while most other compounds are discharged at lower concentrations (1-500 ng/L).

The ability of existing WWTPs to remove pharmaceuticals has been investigated by several researchers who found that they vary and are highly dependent on hydraulic retention time and sludge age (Clara *et al.*, 2004; Daughton & Ternes, 1999; Falås *et al.*, 2012; Matsui *et al.*, 1998; Schaar *et al.*, 2010; Ternes *et al.*, 2004). For example, Falås *et al.* (2012) found that certain pharmaceuticals such as paracetamol, ibuprofen, and naproxen were removed to a large extent (>80%) whereas others such as furosemide and atenolol were not removed as extensively (~20%). A study conducted at Henriksdals WWTP in Stockholm, Sweden, revealed that an increase in sludge age from 10 to 15 days improved the removal of pharmaceuticals from 50% to 60%, but it also increased the risk of floating sludge and other process-related problems (Wahlberg *et al.*, 2010). The consensus is that the existing WWTP systems cannot remove pharmaceuticals to a sufficient degree to safeguard against future ecological problems (Schaar *et al.*, 2010; Ternes *et al.*, 2004).

The first (and currently the only) country in Europe to act on pharmaceuticals in WWTP discharge through legislation is Switzerland. In March 2014, the Swiss Federal Council amended the previous water protection act mandating that WWTPs which fall within certain criteria upgrade the treatment process with an additional treatment stage to reduce the concentration of indicator pharmaceuticals by 80% based on the influent (Eggen *et al.*, 2014, Bourgin *et al.*, 2017). The following criteria specify which WWTPs in Switzerland were required to upgrade their treatment process:

- Those with a load of more than 80 000 p.e.
- Those with a load of more than 8 000 p.e. that contribute to more than 10% of the dry weather flow in the connected stream.
- Those with a load of more than 24 000 p.e. that discharge into a sensitive recipient

One hundred out of seven hundred WWTPs constitute 50% of the total wastewater treatment capacity in Switzerland and fit these criteria and require upgrades (Eggen *et al.*, 2014; Mulder *et al.*, 2015).

As of 2017, two technologies are most ready for implementation, activated carbon and ozone. Activated carbon works through sorption, as pharmaceuticals adhere to sites on the surface. The surface area per gram of activated carbon is usually large (800-1500 m²/g.) due to the expanse of pores within the material (Bansal & Goyal, 2005). Activated carbon can be utilized in two different forms and processes, either in its powdered or granulated form. In its powdered form (powdered activated carbon, PAC), the material is added to the stream of biologically treated wastewater in a contact chamber followed by separation and recirculation of the material. Granulated activated carbon (GAC) on the other hand, is implemented as a carbon filter through which biologically treated wastewater is passed (Cimbritz *et al.*,

2016). Ozone works through a different mechanism of oxidation. The reactive gas oxidizes the pharmaceuticals, breaking up their structure, and the ozone gas is added to biologically treated wastewater before entering a contact chamber. Ozone, in contrast to GAC, does not need a recirculation step as the gas reacts and does not persist in the wastewater for long. An additional benefit of using ozone for pharmaceutical oxidation is the high degree of bacterial inactivation that is achieved (Lee *et al.*, 2016). There are currently few full-scale operational plants for pharmaceutical oxidation running within the EU, and several more are in the design phase (Cimbritz *et al.*, 2016). This growing interest in applying ozone to pharmaceutical oxidation also means that the need for practical knowledge regarding this process is growing. One concern with using ozone for pharmaceutical oxidation in wastewater effluent is the possibility of unintended by-product formation (Section 5.1.5).

5.1 Factors influencing pharmaceutical oxidation with ozone

5.1.1 Ozone dose and the impact of the water matrix

Since ozone addition is an energy intensive process, finding an optimal dosage for pharmaceutical oxidation is imperative. As ozone is added to wastewater, intended and unintended reactions occur which will deplete the concentration of ozone (O_3) and its secondary oxidant hydroxyl radical ($\cdot OH$) that is available for pharmaceutical oxidation. The unintended reactions are called scavenging and they are dependent on the properties of the water. The composite of suspended particles, bacteria, dissolved organic (e.g. organic carbon) and inorganic substances (e.g. nitrite), temperature, and pH comprise what is commonly referred to as the water matrix (i.e. the properties of the water). As no wastewater has the same water matrix, there is no universally applicable ozone dose that is guaranteed to remove pharmaceuticals. Therefore, considerable effort has been made to understand how ozone interacts with the water matrix.

5.1.2 Aspects of the water matrix

The water matrix is a composite of different properties, including suspended solids and colloidal matter. Ozone reacts with and oxidizes, suspended solids (Paper III); pharmaceuticals such as atenolol, ifenprodil, and propranolol are also sorbed onto particles (Yamamoto *et al.*, 2009). This sorption protects the pharmaceuticals from oxidation by ozone (Huber *et al.*, 2005; Zimmermann *et al.*, 2011). As these

compounds are oxidized in the liquid, desorption from the particles occurs leading to further oxidation. The faster the reaction occurs, the faster the desorption is (Zimmermann *et al.*, 2011). Organic carbon molecules will react with ozone, either by direct or indirect (through hydroxyl radicals) reaction pathways. An example of ozone reacting directly with an alkene is depicted in Figure 18. An ozonide is created through a complex reaction. The redox properties of the environment then induce two different end results: an oxidative environment (such as when ozone is present; ketone and carboxylic acid) and a reductive environment (ketone and aldehyde).

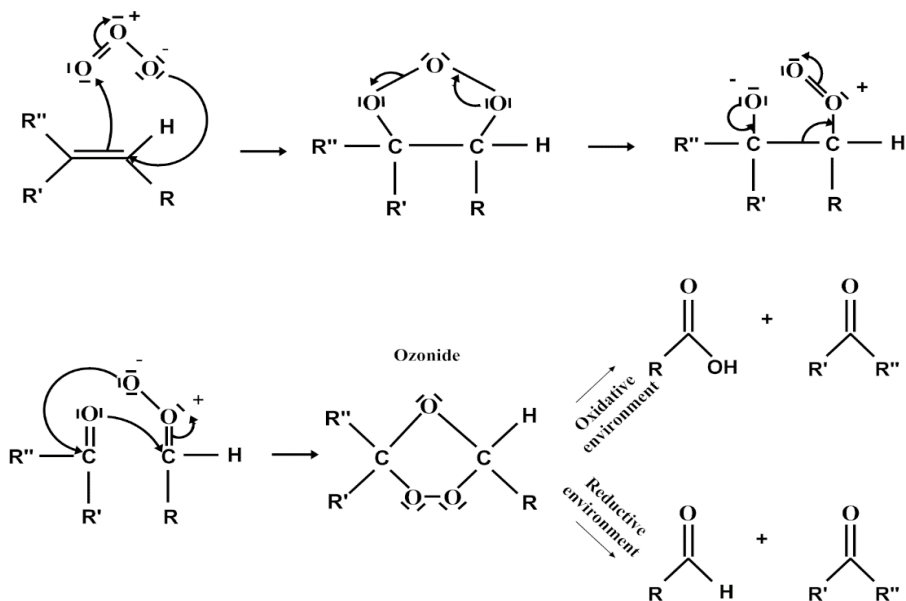

Figure 18
Example of a direct reaction between ozone and an alkene.

The most common ways of measuring organic carbon content when oxidizing pharmaceuticals with ozone are dissolved organic carbon (DOC) and total organic carbon (TOC); DOC is different from TOC as it excludes the particulate carbon (>0.45 μm in size). Although the decay rate of ozone cannot be calculated from the DOC or TOC values alone, it can be used to normalize mixed wastewater and indicate how effective ozone will be at oxidizing pharmaceuticals at full scale. This has been demonstrated recently by Lee *et al.* (2013). Lab-scale trials were conducted in which biologically treated wastewater from nine different WWTPs were spiked with pharmaceuticals and ozonated. Since the wastewater differed in terms of DOC content, ozone was dosed relative to DOC content. Predictions of pharmaceutical oxidation were made using the integrated form of Equation 6 (section 5.1.3) and were accurate ($r^2 = 0.94$) to the measured oxidation in the batch reactor. From these experiments, the researchers proposed that laboratory trials on $\cdot\text{OH}$ production

combined with a DOC-normalized ozone dose and reaction kinetics would produce accurate predictions for pharmaceutical oxidation prior to investing in a full-scale installation.

The importance of the organic carbon content in the water matrix was further substantiated by the experiments conducted in Papers III and IV. When the coagulation, flocculation, and disc-filtration step preceded the addition of ozone, the reduction in the total concentration of pharmaceuticals was substantially more effective than without such a process (Paper III). The pre-treatment lowered the content of suspended solids and organic carbon. In addition, an ozone dose of five g O₃/m³ oxidized 95% of the total concentration of pharmaceuticals when applied after the pre-treatment. Without this pre-treatment, the same ozone dose resulted in an 80% reduction in the total pharmaceutical concentration (Paper III). The pilot-scale experiments at ten WWTPs in Paper IV revealed that the main factor determining the efficiency of pharmaceutical oxidation by ozone was the relative amount of ozone to TOC. Organic carbon compounds also exert a pronounced negative influence on the reactions between ozone and pharmaceuticals which are more dependent on hydroxyl radical reactions than on direct reactions (Wert *et al.*, 2009). As reported recently by Hansen *et al.* (2016), the amount of ozone required to oxidize certain pharmaceuticals increases linearly with DOC, which indicates that organic carbon is a highly important factor in pharmaceutical oxidation.

The pH affects the stability of ozone and the formation of the secondary oxidant, hydroxyl radicals (*OH). As is shown in Equation 3 and Equation 4 (von Gunten, 2003a), increasing pH or adding hydrogen peroxide (increasing OH⁻ or HO₂⁻) accelerates ozone decomposition into *OH. The formation of *OH is important for the oxidation of certain pharmaceuticals as discussed in section 5.1.3.

Equation 3

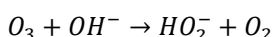

Equation 4

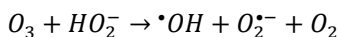

The pH influences the formation of *OH and the reactivity of certain functional groups of pharmaceuticals. The deprotonation of phenols and amines, due to elevated pH for instance, causes these functional groups to become more electronegative and reactive with ozone (Lee & von Gunten, 2012). Margot *et al.* (2013) reported a rise in the reactivity of ciproflaxin, norfloxacin, and ofloxacin when the pH increased from 6.3 to 8. Therefore, the pH of wastewater must be monitored, especially if it is decreasing, as that will have a negative impact on the efficiency of the oxidation process.

5.1.3 Ozone kinetics

Intended and unintended reactions with the water matrix cause ozone to be unstable in water and the ozone concentration to be time dependent. This time dependency of the ozone concentration is called the rate of decay and is expressed in Equation 5. The decay rate of ozone follows a pseudo-first-order reaction that is dependent on the ozone decay rate constant (k_{O_3}) and concentration of ozone $[O_3]$ (Hoigné & Bader, 1994).

Equation 5

$$-\frac{dO_3}{dt} = k_{O_3}[O_3]$$

The concentration of ozone over time is important because the oxidation (Equation 6) is dependent on the concentration of the compound being oxidized $[P]$, ozone $[O_3]$, and hydroxyl radicals $[\bullet OH]$ (von Gunten, 2003a). The constants k_{P,O_3} and $k_{P,OH}$ are second order reaction rate constants for the reactions between compound P, O_3 , and $\bullet OH$, respectively.

Equation 6

$$-\frac{d[P]}{dt} = k_{P,O_3}[O_3][P] + k_{P,OH}[\bullet OH][P]$$

The integrated form (Equation 7) of Equation 6 calculates the oxidation of the compounds. However, it is only valid when the ratio (R_{CT}) of ozone to $\bullet OH$ is constant and the mixing is complete, as in a batch reactor (Zimmermann *et al.*, 2011).

Equation 7

$$\ln\left(\frac{[P]}{[P_0]}\right) = -k_{O_3} \int [O_3] dt - k_{OH} \int [\bullet OH] dt = -\left(k_{P,O_3} + k_{P,OH} \cdot R_{CT}\right) \int [O_3] dt$$

It is difficult to predict an accurate decay rate of ozone in water from theoretical values alone (von Gunten, 2003a). Therefore, the ozone decay rate for wastewater must be measured at a particular temperature and pH with a specific ozone dose (von Gunten, 2003a; Hoigné & Bader, 1994). There are many measured reaction rate constants for O_3 and $\bullet OH$ with different compounds available in the literature (Andreozzi *et al.*, 2003; Benner *et al.*, 2008; Dodd *et al.*, 2009; Hoigné *et al.*, 1985; Huber *et al.*, 2005). From the values of these reaction rate constants alone, it is possible to predict whether the studied compound will easily oxidize. A high ($>10^4/\text{mol s}$) k_{P,O_3} indicates that a compound will be mostly oxidized by direct reaction with ozone. If the k_{P,O_3} is low ($<10^4/\text{mol s}$), the compound is recalcitrant towards ozone and will require oxidation by $\bullet OH$ -radicals (Huber *et al.*, 2005;

Zimmerman *et al.*, 2011). While ozone concentration can be measured directly, $\cdot\text{OH}$ s cannot due to the speed with which they react. Therefore, a probe is used (parachlorobenzoic acid, p-CBA) that reacts with $\cdot\text{OH}$ but not with ozone, and a ratio (R_{CT}) of the concentration of $\cdot\text{OH}$ to O_3 can be derived (Elovitz & von Gunten, 1999).

5.1.4 Evaluating ozone doses

The effectiveness of different ozone doses on the oxidation of pharmaceuticals has been tested extensively. Some researchers have focused on conducting pilot-scale trials (e.g. Papers III and IV), while others have focused on the kinetics involved in the ozone oxidation of pharmaceuticals and on constructing models to determine how well a pharmaceutical can be oxidized. Huber *et al.* (2005) studied the oxidation of different classes of pharmaceuticals on a pilot scale, and four compounds (17 α -ethynyl-estradiol, sulfamethoxazole, diclofenac, and roxithormycin) from these classes were modeled based on Equation 3. Two of the compounds (diclofenac and roxithormycin) were oxidized in accordance with their models and the other two deviated strongly. A proposed reason for this deviation was sorption of the compounds to sludge particles.

Zimmermann *et al.* (2011) performed a comprehensive study where wastewater was subjected to ozone at full scale at WWTP Wüeri in Switzerland. The hydraulic regime of the ozone reactor was assessed using tracer tests and was similar to a series of completely stirred tank reactors (CSTRs) or one plug flow reactor (PFR). The R_{CT} and k_{O_3} of the wastewater was calibrated in a lab using grab samples, and a computer model of the full-scale ozonation of pharmaceuticals was then constructed. When the predicted results were compared to the actual results in the full-scale reactor, slow reacting compounds deviated strongly from the predicted values. The model overestimated the oxidation of these compounds by a factor of 2.5. The same compounds were then modeled and compared to oxidation in a batch-scale reactor. The oxidation of the slow reacting compounds in batch-scale were overestimated by a factor of 1.5 from the predicted values. The deviations in the full-scale trials were attributed to pharmaceuticals being sheltered by colloid particles (as observed by Huber *et al.*, 2005) and 15% of the water flow short circuiting. In the lab-scale trials, the deviations were caused by R_{CT} values fluctuating as the biologically treated wastewater differed between days.

Several researchers have evaluated ozone doses with pilot and full-scale trials. Examples of the range of ozone doses used in pilot and full-scale trials and summaries of their results are presented in Table 2

Table 2

A summary of results from ten pilot and full-scale trials (chronological order) on the oxidation of pharmaceuticals and other micro-pollutants in WWTP effluents with ozone.

Reference	Ozone dose	Summary of the results
Huber <i>et al.</i> , 2005	0.5 – 5 g O ₃ /m ³	90-99% oxidation for a dose > 2 g O ₃ /m ³ . The impact of suspended solids is minor compared to dissolved organic matter.
Nakada <i>et al.</i> , 2007	3 g O ₃ /m ³	80% oxidation of 24 pharmaceuticals with 3 g O ₃ /m ³ when sand filtration precedes ozonation.
Hollender <i>et al.</i> , 2009	0.4 – 1.16 g O ₃ /g DOC	220 micro-pollutants tested. Fast reacting compounds were oxidized to below detection at 0.47 g O ₃ /g DOC. To oxidize the slower reacting compounds to >85% a dose of 0.6 g O ₃ /g DOC was needed. Sand filtration was an effective barrier of NDMA.
Wert <i>et al.</i> , 2009	0.2 – 1 g O ₃ /g TOC	8 fast reacting compounds were oxidized >95% at a dose of 0.6 g O ₃ /g TOC. The 15 slower reacting compounds were oxidized to 20-90% at that dose. When the dose was increased to 1 g O ₃ /g TOC, all but the four slowest reacting compounds were oxidized to >90%.
Schaar <i>et al.</i> , 2010	4.6-7.5 g O ₃ /m ³ (0.6-0.9 g O ₃ /g DOC)	An ozone dose of 0.6 g O ₃ /g DOC was deemed highly efficient at eliminating micro-pollutants.
Zimmermann <i>et al.</i> , 2011	0.21 – 1.24 g O ₃ /g DOC	Of the seven pharmaceuticals, the fast reacting substances were eliminated to below detection at a dose of 0.21 g O ₃ /g DOC. The slower reacting substances required >0.6 g O ₃ /g DOC. Kinetic modelling of the oxidation produced accurate results in lab but the full-scale models consistently overestimated the oxidation of slow reacting substances.
Ibáñez <i>et al.</i> , 2013	0 – 12 g O ₃ /m ³	Of the 52 pharmaceuticals, all but valsartan and irbesartan were consistently eliminated at an ozone dose of between 7-12 g O ₃ /m ³ . Ultrasound was tested in conjunction with ozone and was found to be unnecessary.
Margot <i>et al.</i> , 2013	2.3 – 9 g O ₃ /m ³	70 pharmaceuticals and other micro-pollutants were measured at the inlet to the WWTP and outlet. On average, 50% was eliminated in the standard treatment. The remaining compounds were removed to approximately 70% on average with an ozone dose of 5.7 g O ₃ /m ³ .
Väänänen <i>et al.</i> , 2014, (Paper III)	2 – 9 g O ₃ /m ³	The total concentration of the 24 pharmaceuticals was lowered by 95% when ozone was applied after coagulation, flocculation, and disc-filtration at a dosage of 5 g O ₃ /m ³ . If ozone was applied before this pre-treatment, the concentration of pharmaceuticals was decreased by 80%.
Nilsson <i>et al.</i> , 2017 (Paper IV)	3 – 7 g O ₃ /m ³ (0.2-0.8 g O ₃ /g TOC)	The total concentration of 24 pharmaceuticals was reduced by 78% on average at all ten WWTPs, with an ozone dose of five g O ₃ /m ³ . The relative ozone dose (g O ₃ /g TOC) was highly influential on the elimination of pharmaceuticals.
Bourgin <i>et al.</i> , 2017	0.35 – 0.97 g O ₃ /g DOC	An ozone dose of 0.55 g O ₃ /g of DOC was successful at reducing all indicator substances by ≥80%. In addition to indicator substances, 550 other compounds were analysed. Of these, most were removed by 79% with 0.55 g O ₃ /g DOC.

Table 2 shows the wide span of applied ozone doses and the corresponding results. There are many potential reasons for this variance, though it is most likely due to the different reporting methods for the applied ozone dose ($\text{g O}_3/\text{g DOC}$, $\text{g O}_3/\text{g TOC}$ and $\text{g O}_3/\text{m}^3$) and the different pharmaceuticals that have been analyzed. In all of these trials, ozone was highly effective at oxidizing pharmaceuticals, achieving almost complete elimination of the studied compounds in some cases.

When determining the appropriate ozone doses to use for pharmaceutical removal in a full-scale installation, it is important to identify the aims of the treatment. Since the analysis of pharmaceuticals is time consuming and expensive, it is necessary to limit the number of analyses by introducing standardized indicator compounds. The indicator compounds listed in the Swiss legislation have been reported (Bourgin *et al.*, 2017) and several of these substances were analyzed in Paper III (Figure 19) and Paper IV (Figure 20).

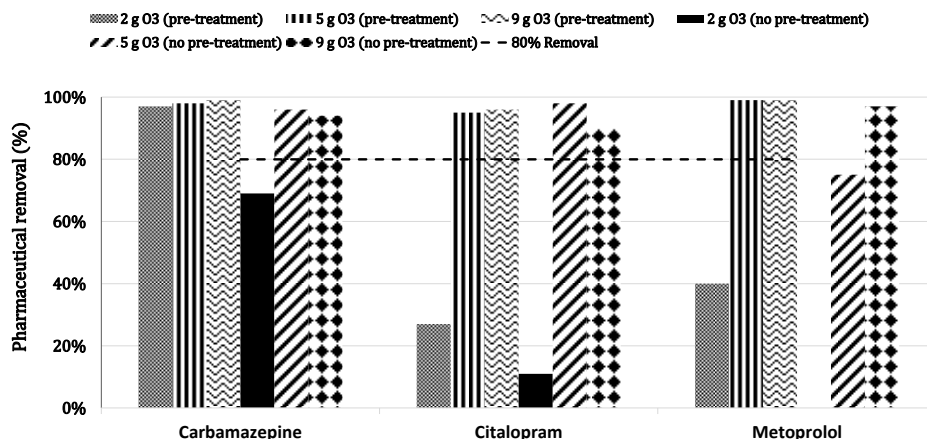

Figure 19
The average removal of indicator substances with or without pre-treatment at Lundåkraverket WWTP (unpublished results from Paper III).

As shown in Figure 19, the removal of indicator substances varies greatly depending on the substance and whether ozone is preceded by pre-treatment. Carbamazepine is almost completely oxidized by as little as two $\text{g O}_3/\text{m}^3$ when ozone is applied after pre-treatment with micro sieving. When no pre-treatment is used, the same ozone dose only removes 70% of carbamazepine. The removal of the other two indicator substances, citalopram and metoprolol, is also affected by pre-treatment. At the lowest ozone dose ($2 \text{ g O}_3/\text{m}^3$), the removal of citalopram reaches 27%, while the same ozone dose yields a removal of 40% for metoprolol when pre-treatment is used. Without this pre-treatment, only 11% of citalopram is removed, and metoprolol is not removed at all. Therefore, using a pre-treatment which lowers the

amount of organic carbon influences how well ozone removes these indicator substances.

The average removal of indicator substances after applying ozone at ten WWTPs is depicted in Figure 20. All indicator substances were removed by 80% with the highest ozone dose (7 g O₃/m³). However, both carbamazepine and diclofenac only needed an ozone dose of three g O₃/m³ to reach 80% removal. Hydrochlorothiazide and metoprolol on the other hand both, required seven g O₃/m³ indicating that these two substances are more difficult to remove. However, hydrochlorothiazide should exhibit higher removal based on its reaction constant with ozone, and this is discussed further in section 5.1.5.

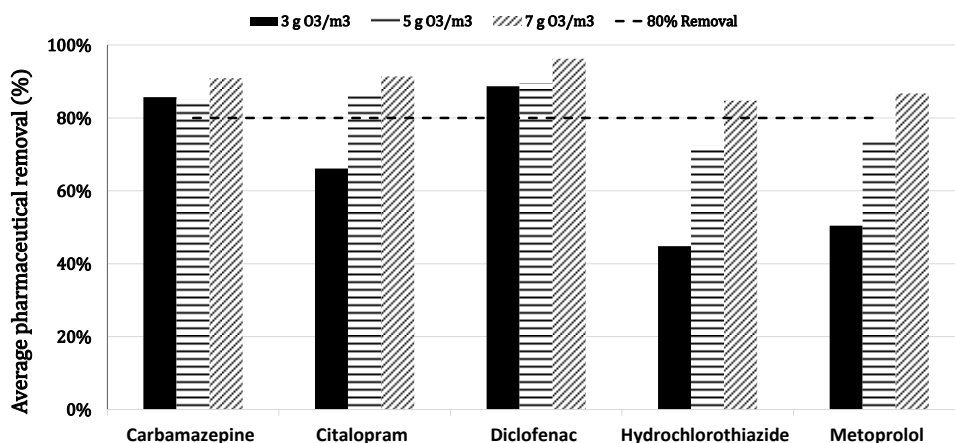

Figure 20
Average removal of indicator compounds at 10 WWTPs (Paper IV).

It can be argued that the effect of ozone addition on pharmaceutical oxidation should only be studied with regard to the effect on individual indicator substances. Evaluating the efficiency of ozone addition by removing individual indicator substances will enable researchers to make comparisons about how well a certain ozone dose will remove a specified compound. These types of comparisons may offer an increased level of accuracy compared to comparisons of the removal of the total concentration of pharmaceuticals, since comparisons are made between the same type of data. However, Switzerland is the only country that has identified and legislated for specific indicator substances. As a result, there is no specified list with which pharmaceuticals should be analyzed when conducting trials, leading to a great variety of pharmaceuticals analyzed in different studies. This variation presents a problem when the results of different studies are compared.

The data in section 5.2.2 is presented as removal of total pharmaceutical concentrations. The relative average inlet concentration of an easily oxidized compound such as diclofenac can provide insight into the sensitivity of this data presentation method. The average inlet concentration of this compound constituted

5.3% of the total average inlet concentration of pharmaceuticals. Removing this compound from the calculations removes 63.9%, 77.8%, and 87.9% of the total pharmaceutical concentration at all ten WWTPs of for the three ozone doses (3, 5, and 7 g O₃/m³ respectively). With diclofenac included in the calculations, the same ozone doses remove of 65.0%, 78.0%, and 88.0% of the total pharmaceutical concentration. This small difference indicates that a single substance does not have a significant impact on the average total removal. Presenting data as the removal of total pharmaceutical concentration may be less accurate than presenting removal of individual compounds. However, in the absence of a standardized list of pharmaceuticals to analyze, it enables comparisons between different trials.

5.1.5 Predicting pharmaceutical removal

It would be advantageous to accurately predict which ozone dose will oxidize pharmaceuticals effectively at full scale at a given WWTP without conducting costly pilot-scale trials. The tested models have produced accurate results in lab trials in batch reactors for fast reacting compounds (Lee *et al.*, 2013; Zimmermann *et al.*, 2009). Accurately modeling the effectiveness at full scale is more complicated though. As Zimmermann *et al.* (2011) demonstrated, the model for the full-scale plant overestimated the oxidation of slow reacting compounds by a factor of 2.5. Though the models did not accurately predict the oxidation at full scale, they can be used as indicators of ozone dose and to suggest the suitability of using ozone. Wildhaber *et al.* (2015) proposed a set of laboratory procedures to evaluate whether ozone is suitable at a specific WWTP, which combined the procedure proposed by Lee *et al.* (2013) (for testing the ozone decay rate combined with kinetic information and •OH exposure) with the quantification of by-product formation and bioassays to monitor toxicity. This would generate a range of ozone doses that are applicable at a specific WWTP, an estimation of the amount of toxic by-product that would be produced, and whether ozone is the best process at that WWTP.

As described in section 5.1.3, it is possible to predict the extent to which a compound will be oxidized by ozone by its reaction rate constant. A low reaction rate constant indicates that a compound is difficult to oxidize by ozone alone and requires $\cdot\text{OH}$. However, these predictions do not necessarily reflect the results of pilot-scale trials, as shown in Figure 21. The average removal of pharmaceuticals with reported reaction constants from Paper IV are displayed in ascending order from left to right according to their reported reaction constant with ozone (k_{O_3} , /mol s). The compounds with low reaction constants such as ketoprofen and ibuprofen ($4.0 \times 10^{-1} \leq k_{\text{O}_3} \leq 9.6$) should display a lower removal on average than the compounds on the right side of the diagram according to the theories in section 5.1.3. As illustrated in Figure 21, the compounds on the left are removed to a lesser extent than those on the right, which seems to verify the predictions. However, the average removal of two of the compounds, paracetamol and hydrochlorothiazide, does not fit this prediction.

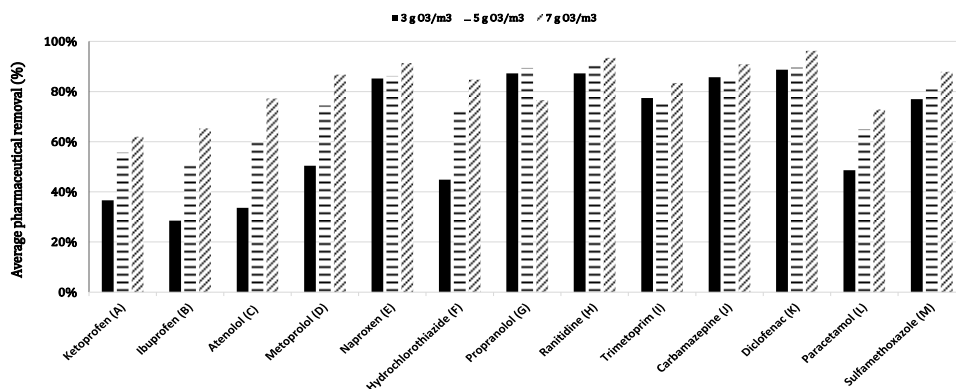

Figure 21

Average removal of individual pharmaceuticals at ten WWTPs with three different ozone doses (3, 5, and 7 g O₃/m³, Paper IV). The displayed pharmaceuticals are sorted in ascending order from left to right according to the value of their reaction constant with ozone (mol⁻¹ s⁻¹): A: $k_{\text{O}_3} = k_{\text{O}_3} = 4.00 \times 10^{-1}$ (Real *et al.*, 2009), B: $k_{\text{O}_3} = 9.60$ (Huber *et al.*, 2003), C: $k_{\text{O}_3} = 1.70 \times 10^3$ (Benner *et al.*, 2008), D: $k_{\text{O}_3} = 2.00 \times 10^3$ (Benner *et al.*, 2008), E: $k_{\text{O}_3} = 2.62 \times 10^3$ (Benitez *et al.*, 2009), F: $k_{\text{O}_3} = 8.4 \times 10^4$ (Borowska *et al.*, 2016), G: $k_{\text{O}_3} = 1.00 \times 10^5$ (Benner *et al.*, 2008), H: $k_{\text{O}_3} = 1.56 \times 10^5$ (Rivas *et al.*, 2009), I: $k_{\text{O}_3} = 2.70 \times 10^5$ (Dodd *et al.*, 2006), J: $k_{\text{O}_3} = 3.00 \times 10^5$ (Huber *et al.* 2003), K: $k_{\text{O}_3} = 6.8 \times 10^5$ (Sein *et al.*, 2008), L: $k_{\text{O}_3} = 2.57 \times 10^6$ (Najjar *et al.*, 2014), M: $k_{\text{O}_3} = 5.70 \times 10^6$ (Huber *et al.*, 2003).

Paracetamol has a reaction rate constant of 2.57×10^6 /mol s (Najjar *et al.*, 2014) which is 3.8 times higher than the reaction rate constant of diclofenac (6.8×10^5 /mol s, Sein *et al.*, 2008). Thus, paracetamol should be removed to at least the same extent as diclofenac, but that was not observed as shown in Figure 21. Hydrochlorothiazide on the other hand, has a reaction constant of 8.4×10^4 /mol s (Borowska *et al.*, 2016) and should therefore display a higher removal average than Naproxen ($k_{\text{O}_3} = 2.62 \times 10^3$, Benitez *et al.*, 2009), especially at the lower ozone dose (3 g O₃/m³). However, the average removal of hydrochlorothiazide at the lowest ozone dose in Figure 21 is not higher than that of Naproxen.

There are several possible reasons that the removal of these two compounds was not as predicted. The most convenient explanation is that the reaction constants are not accurate. However, the methods employed in the evaluation of these constants have been used extensively by several researchers (Benner *et al.*, 2008; Borowska *et al.*, 2016; Dodd *et al.*, 2006; Hoigné *et al.*, 1985; Huber *et al.*, 2003; Najjar *et al.*, 2014; Real *et al.*, 2009; Rivas *et al.*, 2009). As these are the best values currently available in the scientific literature, other reasons for the non-conforming behavior of hydrochlorothiazide and paracetamol in this study should be investigated. As discussed in section 5.1.3, the reaction between a compound and ozone depends on the reaction constant and the concentration of ozone (ozone exposure). The concentration of ozone at a given time within a reactor and the subsequent pharmaceutical oxidation can be modelled by hydraulic models coupled with experimental data of the decay rate of ozone. However, as described earlier in this section (5.1.5), these models do not produce accurate results when compared to data from pilot or full-scale trials (Zimmermann *et al.*, 2009). Predicting the removal of pharmaceuticals based solely on their reaction constants with ozone is a cruder method than the methods used by Zimmermann *et al.* (2009). Since other factors such as the ozone exposure of individual pharmaceuticals are not considered, it is not surprising that the removal of hydrochlorothiazide and paracetamol in a pilot-scale trial does not confirm this cruder prediction.

Lee *et al.* (2013) and Zimmermann *et al.* (2009) demonstrated that pharmaceutical removal models produce accurate results in lab trials. When conducting lab trials, one of the aims is to reduce the number of variables affecting an experiment, which is substantially more difficult to do in pilot and full-scale trials. Other variables will affect experiments in pilot and full-scale trials, such as flow, concentration of organic carbon, temperature, and concentration of pharmaceuticals. These variables cannot be mitigated when conducted at operational WWTPs. However, conducting pilot-scale trials at operational WWTPs will produce results that are closer to those expected from a full-scale operational plant for pharmaceutical removal. Although hydrochlorothiazide and paracetamol do not confirm the predicted results, the general trend in Figure 21 is useful for the design of future trials and operational plants, since the trials in Paper IV are the only published trials that have been conducted at pilot scale at such a large number of WWTPs with the same ozone equipment. The limitations of predicting individual pharmaceutical removal should be considered.

5.1.6 Unintended by-product formation

The procedures for evaluating the suitability of using ozone for oxidating pharmaceuticals proposed by Wildhaber *et al.* (2015) incorporates toxicity testing bioassays. This inclusion occurs because the main uncertainty with using ozone for pharmaceutical removal is that the pharmaceuticals are not oxidized completely to CO₂ (mineralization) with the relevant ozone doses. Depending on the compound, mineralization ranges from 0% to 50% (Klavarioti *et al.*, 2009). As ozonation does not mineralize pharmaceuticals completely, compounds are transformed to oxidation products, most of which have unknown toxicity and structures (Benner & Ternes, 2009a & 2009b; Hollender *et al.*, 2009; Knopp *et al.*, 2016; McDowell *et al.*, 2005; Petala *et al.*, 2008; Wert *et al.*, 2007). N-nitrosodimethylamine (NDMA) is a by-product produced by ozonation. It is listed as a probable carcinogen and can be formed by ozonation (albeit at a low yield) when dimethylamine is present in water that is being ozonated (Andrzejewski *et al.*, 2003; Richardson, 2003). Bromate is another known byproduct which is also listed as a probable carcinogen. It is formed by a complex reaction between ozone and bromide in drinking water and wastewater (Chys *et al.*, 2017; von Gunten, 2003b; Richardson, 2003; Wert *et al.*, 2007). Bromate is such a problematic oxidation by-product that it has been given a maximum threshold limit in the US of ten µg/L in drinking water (USEPA, 1998).

There are other by-products formed when ozone reacts with pharmaceuticals and other micro-pollutants. As there are approximately 3000 different active pharmaceutical compounds approved for sale within the EU (Ternes *et al.*, 2004), much time and money would be required to investigate them for toxic by-product formation due to ozonation. In the meantime, studies have been performed at WWTPs with full-scale and pilot-scale ozone installations to investigate the formation of oxidation by-products. Wert *et al.* (2007) studied the formation of bromate in wastewater disinfection in lab and pilot-scale trials. Bromate was formed after the ozone dose exceeded the initial ozone demand (the fast ozone decomposition in the first 30 s of addition), following a linear correlation to the transferred ozone dose above 3.1 g O₃/m³. When the ozone dose was increased to 4.5 g O₃/m³, the bromate concentration exceeded the ten µg/L threshold for drinking water.

Hollender *et al.* (2009) studied the formation of NDMA and bromate in full-scale trials. Bromate was formed during the trials at low levels (< 10 µg/L) that did not constitute a problem, while more NDMA was formed at concentrations up to 21 ng/L after ozonation. Stalter *et al.* (2010a) investigated the toxicity of ozonated wastewater at full scale using the early life stage toxicity test (FELST) with rainbow trout. They found that ozonated biologically treated wastewater had a substantial negative impact on the early development of these fish, resulting in increased sensitivity to predation. Stalter *et al.* (2010b) elaborated on their earlier findings and

initiated a battery of in-vivo toxicity tests in pilot-scale trials. In addition to identifying which toxicity tests were sensitive enough for use, they found that ozone treatment increased the toxicity significantly compared to regularly treated wastewater. Furthermore, Margot *et al.* (2013) studied bromate formation with pilot-scale ozonation at Lausanne WWTP in Switzerland. High concentrations (350 µg/L) of bromide in the biologically treated wastewater caused concerns that high levels of bromate could be formed. However, the bromate levels after ozonation remained below the ten µg/L threshold for all ozone doses below 1.4 mg O₃/ mg DOC (7 g O₃/m³ in this case).

As the researchers above found, oxidation by-products are formed during the ozonation of wastewater, which can result in wastewater with increased toxicity. There are however processes that can mitigate this effect. Oxidation by-products are generally more biodegradable than their parent compounds (the parent compound persists through the entire WWTP at the point of ozonation). Therefore, a biologically active sand filter can reasonably be employed to lessen the effect of these by-products. Filtration through a sand filter with biologic activity reduces NDMA concentrations and general toxicity to the levels observed before ozonation (Chys *et al.*, 2017; Hollender *et al.*, 2009; Krauss *et al.*, 2009; Stalter *et al.*, 2010a & 2010b). However, bromate is unperturbed by a sand filter, as there no impact on bromate concentration (Margot *et al.*, 2013). Since bromate is not captured in a biologically active filter, other means of controlling bromate is needed. Soltermann *et al.* (2017) studied three different methods for mitigating bromate formation: lowering the concentration of bromide with membrane, electrochemical or adsorption techniques (Watson *et al.*, 2012); decreasing the ozone dose; and adding H₂O₂. There are drawbacks to all these strategies, and researchers conclude that there is no universally applicable solution to bromate formation. Thus, strategies must be applied on a case-by-case basis. A recent study by Knopp *et al.* (2016) investigated the performance of a biological filter for removing by-products and compared it to a GAC filter. The by-product of tramadol oxidation (tramadol-N-oxide) was not removed in a biological filter, though it was removed in the GAC filter. More research is needed to identify the problematic by-products and their effects in the environment and strategies to limit the concentration of these compounds.

5.2 Ozone addition in practice

Different facilities for ozone addition have been utilized by researchers in the last decade. As the interest in installing ozone for pharmaceutical oxidation grows, the need for practical information regarding that process increases. The kinetic expressions governing ozone reactions are all dependent on the ozone concentration within liquid wastewater. Thus, maintaining an ozone concentration within the wastewater long enough to facilitate both direct and indirect reactions is paramount to the success of the intended oxidations. The concentration profile of ozone throughout the reactor is governed by the transferred amount of ozone, the reactions taking place (depleting ozone), and the hydraulic regime of the reactor. The engineering principles behind reactor design and hydraulic models are not addressed in this work, but interested readers should refer to the reference literature made available by Green and Perry (2008).

5.2.1 Hydraulic retention time

A reactor's primary purpose is to contain the reacting substrates for sufficient time for them to react. The time a liquid stay within a reactor is called the HRT. The hydraulic retention time of any reactor is governed by the volume of the reactor and the volumetric flow through it. As the flow through the reactor is governed by the throughput of the WWTP (assuming a full-scale installation) the volume of the reactor is the only parameter open to alteration. There are economic and practical considerations as well. For example, as more volume is needed, the construction of the reactor becomes more expensive and more space is required. It is therefore of interest to investigate the HRTs used in both research installations and current full-scale installations at WWTPs. As is apparent from Table 3, the HRTs applied in the research installations vary greatly from 2 to 27 minutes. As these installations are intended for research, the variation in HRT is not as surprising as the HRT and its influence on pharmaceutical oxidation is one factor that ought to be investigated.

Table 3

List of HRTs used in research installations for oxidation of pharmaceuticals with ozone.

Reference	HRT (min)
Huber <i>et al.</i> , 2005	4
Nakada <i>et al.</i> , 2007	27
Hollender <i>et al.</i> , 2009	7-10
Wert <i>et al.</i> , 2009	24
Schaar <i>et al.</i> , 2010	17-18
Zimmermann <i>et al.</i> , 2011	7-10
Ibáñez <i>et al.</i> , 2013	1 – 13
Margot <i>et al.</i> , 2013	20
Väänänen <i>et al.</i> , 2014 (Paper III)	2.6
Nilsson <i>et al.</i> , 2017 (Paper IV)	5

The HRTs used in operational plants (Table 4) are all longer than ten minutes. When the first full-scale ozone installation for pharmaceutical oxidation in Sweden (Nykvarnsverket, Linköping) was designed, an HRT of 12 minutes at average flow was chosen. The designers measured the ozone decay rate (see section 5.1.3) several times and did not find an ozone residual after eight minutes and with a 50% safety margin, 12 minutes was chosen as design HRT (Sehlén, 2017).

Table 4

A selection of HRTs used in operational full-scale installations for pharmaceutical oxidation with ozone.

WWTP	p.e.	HRT (min)	Reference
Neugott, Dübendorf, Switzerland	150 000	13-40	Cimbritz <i>et al.</i> , 2016
Station d'épuration des Bouillides, Sophia Antopolis, France	26 000	15	Cimbritz <i>et al.</i> , 2016
Nykvarnsverket, Linköping, Sweden	235 000	12	Sehlén, 2017

The trials conducted for Paper IV applied an HRT of five minutes at all ten WWTPs. Though the water matrix was different for all tested wastewater, the average elimination of pharmaceuticals reached 78% when five g O₃/m³ was applied. In Paper III, the HRT was relatively low at only 2.6 minute, which did not seem to have a negative impact on the pharmaceutical oxidation. Furthermore, Hollender *et al.* (2009) reported that a decrease in HRT from nine to four minutes did not appreciably influence the elimination of pharmaceuticals. Although a low HRT does not seem to influence the oxidation of pharmaceuticals, it can cause ozone to remain in the water after the reaction vessel which may negatively affect subsequent biological filters. As such, Hollender *et al.* (2009) recommend that the HRT should be in the five to ten minute range. To minimize HRT and the cost of construction, it would be beneficial to incorporate measurements of ozone decay rates in the design phase (see section 5.1.3).

5.2.2 Dose control

In Papers III and IV, ozone doses proportional to the wastewater flow were applied ($\text{g O}_3/\text{m}^3$). Since the trials in Paper IV were conducted at ten separate WWTPs with varying water matrices, the efficiency of a set flow proportional ozone dose can be assessed. When comparing the reduction in total pharmaceutical concentration for the three ozone doses (3, 5 and $7 \text{ g O}_3/\text{m}^3$) at the ten WWTPs (Figure 22), a flow proportional dose of five $\text{g O}_3/\text{m}^3$ is sufficient (average 78%) to reach the 80% reduction in pharmaceuticals stipulated by the Swiss legislation.

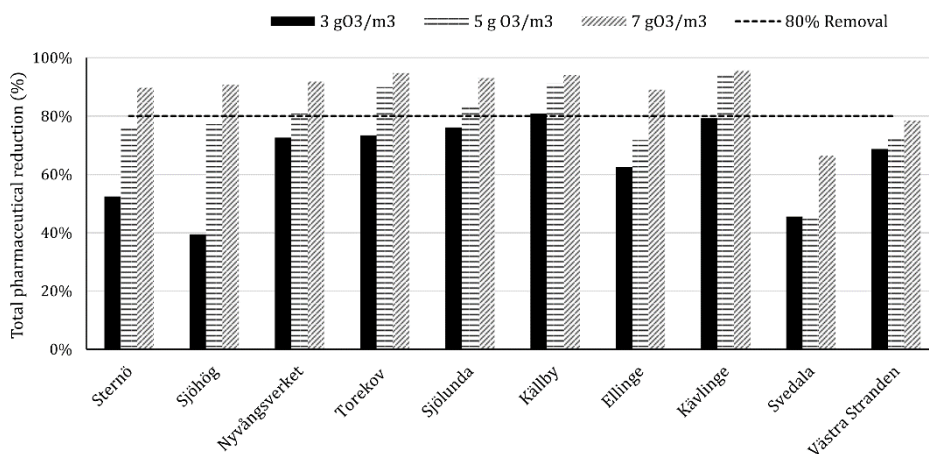

Figure 22
Reduction in total pharmaceutical concentration by ozone addition at ten WWTPs (Paper IV).

There are rather large variations in the results. For example, a flow-proportional dose of five $\text{g O}_3/\text{m}^3$ in Ellinge WWTP yielded a reduction in total pharmaceutical concentration of 72%, while the same dose in Torekov WWTP yielded a reduction above 90% reduction. Since the HRT and experimental procedure was the same at all plants, the only difference is the properties of the water matrix (TOC). When the ozone dose used in Paper IV is related to the TOC concentration in the inlet to the pilot-plant, a more complex picture emerges (Figure 23).

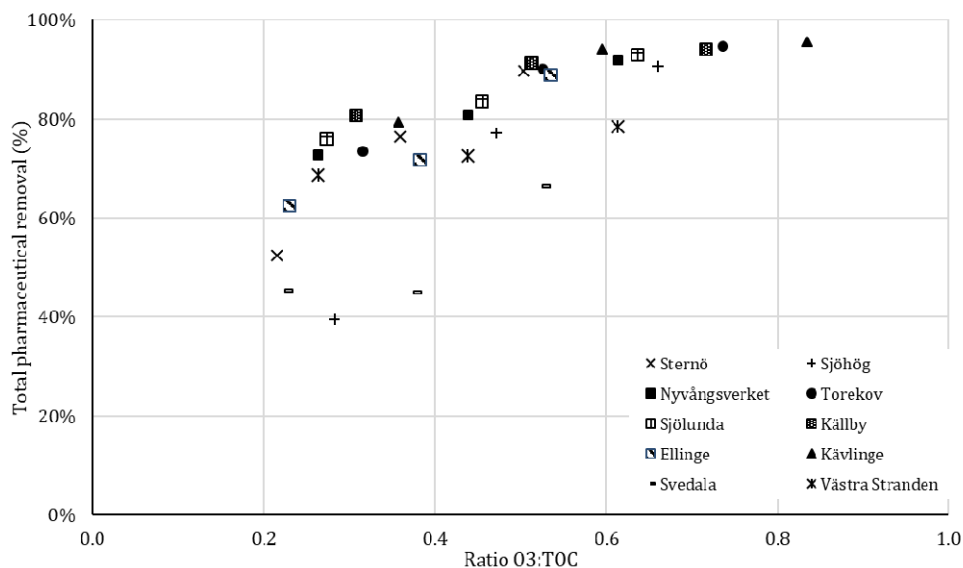

Figure 23
Total pharmaceutical reduction as a function of the TOC-relative ozone dose ($\text{g O}_3/\text{g TOC}$), (Paper IV).

The general trend in reduction efficiencies when plotted against the TOC-relative ozone dose increases with an increasing ozone dose as expected. One of the stated aims of Paper IV was to investigate the impact of TOC content on pharmaceutical oxidation and evaluate whether TOC could be used as a general model for controlling the ozone output of a full-scale plant. That aim was only partially successful as the observed general trend was diffuse at the lower end of the ozone doses ($0.2\text{--}0.4 \text{ g O}_3/\text{g TOC}$). Although a general model of the impact of organic carbon on the pharmaceutical reduction could not be construed from these data points, the importance of the organic carbon content within the water matrix was further substantiated. As the organic carbon content within the water matrix is highly influential for the efficiency by which ozone oxidizes pharmaceuticals, trials (and operational plants) have been running with online measurement of organic carbon as the controlling parameter for ozone addition (Cimbritz *et al.*, 2016; Hollender *et al.*, 2009; Stapf *et al.*, 2016; Zimmermann *et al.*, 2011). There were no reported problems with this dosage control in the research installations. However, there have been cases of the selected organic carbon sensor malfunctioning at operational plants, necessitating the switch to flow-proportional ozone dosage (Cimbritz *et al.*, 2016; Mulder *et al.*, 2015; Sehlén, 2017).

During the pilot-scale trials, prior to designing a full-scale operational installation at Nykvarnsverket, Linköping, an online organic carbon sensor for ozone dosage control was tested and deemed unreliable (failure due to bio-fouling). Therefore, the ozone dose was controlled by measuring the ozone concentration in the off-gas from

the contact basin and adjusting the ozone dose to keep a constant low ozone concentration. The results from these trials were such that the soon to be operational full-scale installation at that WWTP will use that mode of control while also evaluating other types of sensors for dosage control (Sehlén, 2017).

The accuracy and reliability of organic carbon sensors have been reviewed. Bourgeois *et al.* (2001) reviewed the state-of-the-art sensors in 2001 for on-line measurements of organic carbon and found that the application of these sensors were limited due to fouling and short lifetimes. Vanrolleghem and Lee (2003) also reviewed these types of sensors and found that they produced accurate results if the samples were properly filtered to reduce particles and the sensors were not fouled by biological growth. Several researchers have implemented online measuring tools for organic carbon in pilot and full-scale trials to control ozone addition but reliability issues at operational plants have been reported (Cimbritz *et al.*, 2016; Sehlén, 2017). Moreover, even if an online organic carbon meter is successfully implemented, it is not guaranteed that using and maintaining such a device will result in lower running costs for the ozone installation. A dynamic ozone dose does have the potential to lower the running cost of ozone by adjusting the ozone amount to the level of organic carbon. However, a balanced and effective WWTP will produce treated wastewater with an even organic carbon content, negating the need for rapid changes in ozone dose due to rapid changes in organic carbon content. A flow-relative dose may therefore be as effective as using online measurements of organic carbon.

5.2.3 Cost

Ozonation is an energy-intensive process, and it requires labor and infrastructure such as ozone generators, reaction tanks, piping, and automation, which increases the cost of wastewater treatment. A recent study by Mulder *et al.* (2015) presents a detailed cost calculation for three different processes of micro-pollutant reduction, ozone with sand filtration, PAC with sand filtration, and GAC. The calculation shows that a WWTP in the Netherlands with a capacity of 100 000 p.e. could expect an increased cost of 0.18 € (+/- 0.03€)/m³ of treated wastewater if an ozone process is installed. The cost of using PAC is 0.20 € (+/- 0.03€)/m³ of treated wastewater and the figure for GAC is 0.27 € (+/- 0.04€)/m³ of treated wastewater. These figures are comparable to cost calculations made in Switzerland and Germany (Mulder *et al.*, 2015). However, cost calculations are dependent on the assumptions made for each calculation. The figures presented by Mulder *et al.* (2015) assume that an ozone dose of 0.7 g O₃/g DOC is used with an HRT of 25 minutes and a concentration of DOC in the wastewater at 7 to 15 mg of DOC/L at peak dry weather flow. Therefore, these costs are not applicable if the process is designed differently.

6 Ozone and filamentous bulking sludge

The secondary clarifier is one of the most critical processes in WWTPs with activated sludge. A disturbance in this process will propagate backwards and cause further problems in the other processes, such as low throughput, sludge release, and surface floating sludge. One cause of slow-settling sludge is filamentous bacteria, which form long web-like structures and cause a phenomenon called filamentous bulking sludge (van Leeuwen, 1992; Martins *et al.*, 2004). There are two different methods available to the WWTP to remedy the problems caused by filamentous bulking sludge: specific and non-specific. The specific method involves a selector reactor which, depending on the filamentous species that are present, imposes ecological regimes designed to inhibit the growth of filamentous bacteria in favor of non-filamentous bacteria. The non-specific methods entail adding a chemical to the sludge, such as chlorine, ozone, aluminium chloride, or polyaluminium chloride to either attack the filamentous bacteria directly (ozone and chlorine) or change the hydrophobicity of the target and hindering their uptake of lipid substrate (van Leeuwen, 1988; van Leeuwen & Pretorius, 1988; Saayman *et al.*, 1996 & 1998; Paris *et al.*, 2005).

Since van Leeuwen (1988) published an article describing how ozone was applied at the Rooiwal Sewage Works in Pretoria, South Africa, ozone has been known to alleviate the problems caused by filamentous bulking sludge. Ozone was applied at two different points in the pilot-scale activated sludge plant, directly in the aerated zone and into the return activated sludge. In the aerated zone, three different doses were used (1, 2, and 4 g O₃/kg SS), while a single dose of two g O₃/kg SS was used in the return sludge. The results clearly show that ozone addition lowers the diluted sludge volume index (DSVI) of the sludge, although the addition of ozone in the return sludge was more efficient. An article published by Saayman *et al.* (1998) shows that when ozone is applied at full scale to the aerated basin, the sludge volume index (SVI) improves even at as low a dose of 0.4-1.4 g O₃/kg SS. Wennberg *et al.* (2009) described the use of ozone to reduce filamentous bulking sludge at full scale at Klagshamn WWTP, Sweden. Ozone was applied at full-scale on a portion of the return activated sludge at a dosage of six g O₃/kg SS, which was sufficient to lower the DSVI significantly in that study.

A more recent study published by Lyko *et al.* (2012) details the application of ozone in the return sludge flow at full scale. Ozone was applied at a dose of 1.6 g O₃/kg SS and approximately six percent of the return sludge flow was treated. The treated line was subjected to ozone for one week every month for approximately eight consecutive months. The SVI clearly improved in relation to the control line both initially and throughout the entire trial period.

The way ozone is added to the return sludge flow could be important. For instance, ozone can be added at a low constant rate for several weeks or months, or for a shorter time but with a higher dosing rate. A recent study by Levén *et al.* (2016) investigated the full-scale use of ozone at Himmerfjärden WWTP (295 000 p.e.) south of Stockholm, Sweden. Ozone was added at a dosage of 6.6 g O₃/kg SS to a portion (10%, 30 m³/h) of the return activated sludge for 69 days, after which the dose was lowered to 4.4 g O₃/kg SS. After one week of adding 6.6 g O₃/kg SS, the SVI dropped significantly compared to the control treatment line. The lower dose (4.4 g O₃/kg SS) was sufficient to keep the SVI low in the experimental treatment line. Four weeks after the ozone addition ended, the SVI returned to the levels observed before the onset of the experiment.

The technique of applying ozone to reduce filamentous bulking sludge has not been widely applied or studied in many full-scale or pilot-scale cases. Though the reason for this is unknown, it could be that the method has not been promoted to the same degree as chlorination. The barrier of applying a costly technique such as ozone can also be a factor in its low usage at WWTPs for filamentous bulking control. The cost of having filamentous bulking issues at the WWTP is also significant. For instance, a comparison of cost between using flocculation chemicals (Kemira, PAXTM), adding ozone, and bringing in pump trucks to alleviate the problem of floating filamentous sludge has been published by Wennberg *et al.* (2009). The comparison showed that when considering investment and operating costs, ozone was slightly less expensive than pump trucks, and flocculation chemicals was the least expensive method. However, if the chemicals do not work (as in Klagshamn WWTP, Wennberg *et al.*, 2009), ozone is a competitive option.

The use of ozone to reduce the amount of excess sludge has received more attention. In most of the cases studied, ozone was introduced to the return activated sludge with a high dosage (50 g O₃/kg TSS, Dytczak *et al.*, 2007) than for filamentous bulking control. The results obtained by the researchers indicate that ozone can be used to limit or negate the production of excess sludge and to improve the settling qualities of the sludge (Yasui *et al.*, 1996; Dytczak *et al.*, 2007; Chu *et al.*, 2009).

6.1 Reducing filamentous sludge bulking with ozone

Trials with ozone to reduce filamentous sludge bulking were conducted at Klagshamn WWTP in Malmö and Öresundsverket WWTP in Helsingborg in 2011 (Papers I & II). The two plants are highly suited to host scientific trials due to their separate treatment lines, with the same influent composition as the experimental line. The scale of the ozone plants is denoted as full scale since the equipment were sufficient to treat a full treatment line at a time. Both WWTPs have experienced problems with their treatment process caused by insufficient settling due to filamentous sludge. At Klagshamn WWTP, the problems caused by filamentous sludge were pronounced, causing sludge to be washed out into the polishing sand filter. Both plants have tried different methods to address the filamentous bulking sludge, such as altering the aeration rate and sludge age, with varying degrees of success. Klagshamn WWTP tested applying flocculation chemicals (Kemira, PAXTM) for four consecutive years starting in 2006, the improvement in DSVI was highly variable (Wennberg *et al.*, 2009) causing the plant to seek alternatives.

Since neither plant successfully solved the filamentous sludge problem with specific measures, they used ozone instead. A total of eight ozone treatments were conducted at Klagshamn WWTP for Papers I and V (Table 5). The trials for Paper I were conducted with different flows of return sludge and ozone output (between 620 – 900 g O₃/h). The reason for this variation was to find a viable ozone dosing strategy at that WWTP; a more detailed description of the first series of trials at Klagshamn WWTP is available in Paper I. The operation of the ozone unit at Öresundsverket WWTP (Ö-I in Table 5) was more straightforward than at Klagshamn WWTP, as ozone was applied at a constant rate of 900 g O₃/h to ~42 m³/h of return sludge for 45 days (Paper II).

Table 5

Summary of the ozone treatments applied for Paper I (K-I to K-V), Paper II (Ö-I), and Paper V (K-VI to K-VIII).

Treatment number	WWTP line	Ozone addition (g O ₃ /h)	Return sludge flow (m ³ /h)
K-I	1	620	25
K-II	1	620	25
K-III	1	900	32
K-IV	2	620	25
K-V	2	900	32
K-VI	2	393	26
K-VII	2	537	26
K-VIII	2	653	26
Ö-I	2	900	42

6.2 Impact on SVI and DSVI

The results of the trials conducted at Klagshamn and Öresundsverket WWTPs are summarized in Table 6. The SVI from both lines at Klagshamn WWTP (K-I to K-V) showed a significant decrease from all ozone treatments reaching an SVI of approximately 100 mL/g. The K-VI to K-VIII trials were conducted differently from K-I to K-V. The aim of the K-VI to K-VIII trials was to investigate the direct effect of ozone addition on the sludge (for details see Paper V) and not the overall activated sludge process. Therefore, the trials were all conducted on a single day and the resulting DSVI was measured on the sludge, leaving the reaction chamber directly after ozone addition. At Öresundsverket WWTP, it was not possible to measure the SVI directly since the sludge volume of the activated sludge was too high (approximately 800 mL/L). Therefore, measurements from the diluted sludge volume index (DSVI) were chosen instead. Starting at a DSVI value of 170 mL/g, the DSVI decreased after approximately ten days and reached a DSVI of 100 mL/g after 40 days of ozone addition.

Table 6

Summary of the results from the ozone trials presented in Paper I (K-I to K-V), Paper II (Ö-I), and Paper V (K-VI to K-VIII).

Treatment #	Days of treatment	Start SVI or DSVI (mL/g)	End SVI or DSVI (mL/g)	SS or TSS in RAS (kg/m ³)	Dose (g O ₃ /kg SS or TSS)
K-I	35	SVI: 261	SVI: 86	3.1 - 6.7	3.7 - 7.7
K-II	53	SVI: 143	SVI: 96	4.3 - 7.9	3.1 - 5.8
K-III	26	SVI: 251	SVI: 73	4.3 - 6.1	4.6 - 6.5
K-IV	26	SVI: 185	SVI: 78	1.9 - 5.3	4.7 - 13
K-V	32	SVI: 220	SVI: 86	4.7 - 6.7	4.2 - 6.0
K-VI	NA*	DSVI: 82	DSVI: 75	TSS: 5.0	3.0
K-VII	NA*	DSVI: 75	DSVI: 54	TSS: 5.1	4.0
K-VIII	NA*	DSVI: 54	DSVI: 52	TSS: 5.1	4.8
Ö-I	45	DSVI:170	DSVI: 100	4.3 - 7.6	2.8 - 5.0

* Not applicable, these trials were run for 40 minutes each and on the same day.

In Figure 24 and Figure 25, the aerated zones of two parallel treatment lines at Öresundsverket WWTP show a clear difference in the amount of surface floating sludge. Figure 24 shows a treatment line without ozone treatment and Figure 25 shows a line after ozone application. The pictures were taken the day after the ozone plant had been running for 45 days. At the start of the ozone treatment, no treatment lines had floating sludge on the surface (Figure 25).



Figure 24
Aerated zone of untreated line at Öresundsverket WWTP



Figure 25
Aerated zone of ozone treated line at Öresundsverket WWTP.

Another issue which is not as apparent from Table 6 is the length of time required to reach acceptable SVI or DSVI levels. The number of days of ozonation only specifies the total number of days that ozone was introduced to the return sludge and not how long it took to reach acceptable levels. For instance, the K-II run was operated with ozone for a total of 53 days, and the SVI levels were satisfactory (<100 mL/g) within ten days. The previous run before that, K-I, was operated with ozone for 35 days, while the SVI reached satisfactory levels within approximately 30 days. The time it took to reach acceptable levels of SVI with ozone application varied substantially throughout the Klagshamn trial (Paper I). Although the reason for this variance is not known, one reason may be that the biological makeup of the sludge is in a state of constant change due to external factors such as influent composition and temperature, causing the impact of ozone to change. Overall, approximately two to six weeks of ozone addition was required throughout all trials to reach satisfactory levels of SVI or DSVI.

Sludge samples from the trials at Öresundsverket WWTP (Paper II) were subject to quantitative Fish analysis (Q-Fish). Three sludge samples were taken from the activated sludge line that were subjected to ozonated return active sludge throughout the course of the trials (after 21 and 43 days into the trial as well as 71 days after the trials). Q-Fish is a method that can be used to quantify the different species of bacteria within a sludge sample. As the analysis shows, the relative quantity of the

different species in the sludge did not change as a result of ozone addition, though a small decrease in the filament index (from 2 to 1.5) was observed. In addition, the interconnecting structure between the flocs was not broken by the ozone addition. The conclusion from Paper II was that ozone impacts the physical properties of sludge (i.e. settling speed). However, the actual mechanism of ozone attack was not clear.

To further understand how ozone interacts with bacteria in activated sludge, trials were conducted at Klagshamn WWTP in 2016 (Paper V). As ozone increases methane production if applied to sludge prior to anaerobic digestion (Bougrier et al., 2006), batch scale digestion of ozonated sludge was also included in this trial. As described earlier in this thesis (section 5), ozone also oxidizes pharmaceuticals and other micro-pollutants (MPs). Therefore, the concentrations of ten MPs in the sludge were also analyzed. The experimental equipment was the same as in Paper I (Figure 3) with the addition of a sampling point after the pressurized reactor. Three ozone doses were used: 3.0, 4.0, and 4.8 g O₃/kg TSS. Samples of the ozonated return activated sludge (RAS) were taken after the pressurized reaction vessel and subject to LIVE/DEAD[®] analysis (BacLight[™]), anaerobic digestion lab-scale trials, and analysis of micro-pollutant concentrations (for details see Paper V).

LIVE/DEAD[®] analysis stains bacteria with damaged cell membranes (inactivated) in red and undamaged cell membranes in green. As illustrated in Figure 26, the number of red-stained bacteria in the pictures increases with an increasing ozone dose. The inactive filamentous bacteria are predominately situated on the outside of the flocs, while the filaments remain active within them.

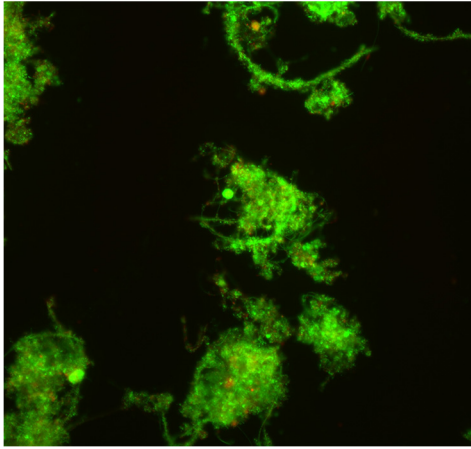

A: Untreated sludge

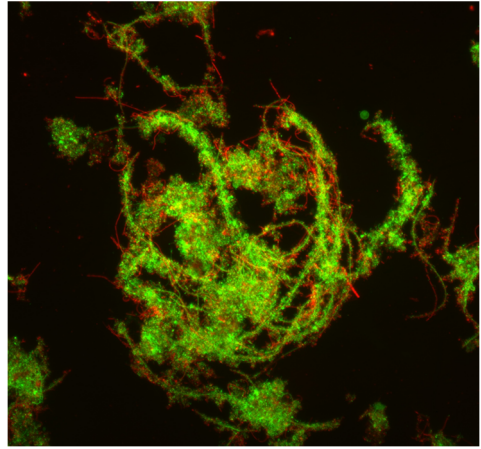

B: 3 g O₃/kg TSS

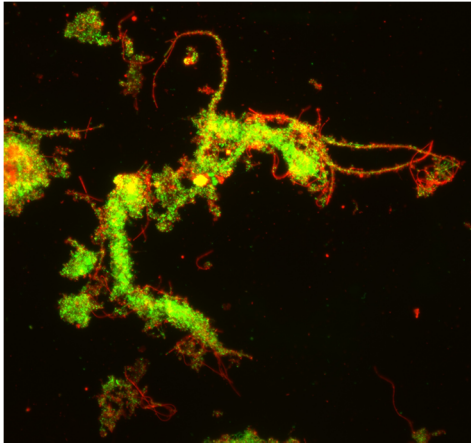

C: 4 g O₃/kg TSS

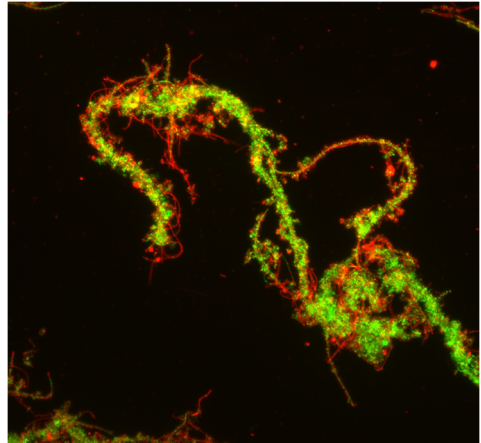

D: 4.8 g O₃/kg TSS

Figure 26
Live/Dead microscopy pictures of untreated- (A) and O₃-treated activated sludge (B-D) (Paper V). Photo Simon Bengtsson.

Further microscopy analysis of the samples revealed that as the ozone dose increased, the number of filaments extending from the flocs into the water phase decreased, and those that were left were to a high degree inactive. The ozone addition also broke interconnecting structures between different flocs. Interconnecting structures between flocs increased the surface area of these flocs; the larger the surface area, the higher the drag (resistance) between the water and floc becomes. Breaking these structures, lowers the surface area and increases the settling speed, which was confirmed by the DSVI measurements. Morphological studies of the samples (visual characteristics) indicated that ozone was selective towards *Microthrix Parvicella* at low doses, only affecting Type 0041 filaments (another common filament-forming bacteria) when the dose increased. The analysis of micro-pollutants (MPs) did not show any change in MP concentration due to ozone addition. Ozone did not increase the methane potential of the ozonated sludge either. As shown in sections 5.1.3 and 5.2.2, organic carbon will scavenge ozone to a high degree. Considering the amount of organic carbon present in activated sludge, the inability of ozone to oxidize micro-pollutants was not unexpected. It was also not surprising that ozone did not increase the methane potential of the sludge, as the ozone doses used for filamentous sludge bulking control are only a small fraction of the doses with reported effects on methane production (Bougrier *et al.*, 2006; Carballa *et al.*, 2007; Weemaes *et al.*, 2000).

When comparing the microbial results obtained in Paper II to the results from Paper V, there is a clear difference. The Q-fish analysis did not show any change in the quantity of the different microbial species, whereas Live/Dead[®] analysis showed that the filaments outside the flocs decreased substantially. Ozone did not break the interconnecting structures between the flocs in Paper II as it did in Paper V. However, there are problems associated with comparing the microbial results of these two trials. First, the microbial methods employed (Q-Fish and Live/Dead[®]) were not the same. Live/Dead[®] analysis is a staining method which differentiates between bacteria with intact cell walls and bacteria with compromised cell walls (Boulos *et al.*, 1999). Q-Fish is a method that uses gene probes to highlight bacterial species which can then be quantified in a fluorescence microscope (Kragelund *et al.*, 2009). If a microorganism is deactivated by ozone it may not mean that the gene probe cannot interact with the unique genes of that bacteria.

The samples in the trials were also not extracted in the same way. For Paper II, the samples were extracted from the activated sludge line which had a portion (~5%) of its return sludge flow subjected to ozone. Since the samples were taken immediately after the reaction chamber in Paper V, the samples in Paper II were not subjected to ozone with the same intensity as in Paper V. Therefore, the results obtained from Papers II and V are not readily compared. However, as shown in Paper V, ozone rapidly reduces the number of active filaments and breaks the interconnecting structures between flocs. And as shown in Papers I and II, the addition of ozone in

the return sludge flow results in faster settling sludge. However, it is still not clear how the filaments in the main stream are affected when ozone is added as part of the return sludge flow.

6.2.1 Impact on biological nutrient removal

Two of the most important measurements in a WWTP are the concentration of nitrogen and phosphorus compounds in the effluent since they are specified in the plant specific discharge limits. The concentration of these discharged nutrients discharged is a measurement of how well the plant is operating. A disturbance in the nitrification or denitrification, biological phosphorus removal, or sludge that is discharged from a secondary settler that is hindered by filamentous sludge will be detected by measuring the concentration of these compounds in the discharge from the WWTP. To monitor the nutrient removal performance of the individual treatment lines in these trials (Papers I and II), the nitrification rates (and biological phosphorus removal in Paper II) of sludge collected from these lines were studied. The nitrification rates of the treatment lines that were subjected to ozonation in Papers I & II are presented in Figure 27 and Figure 28.

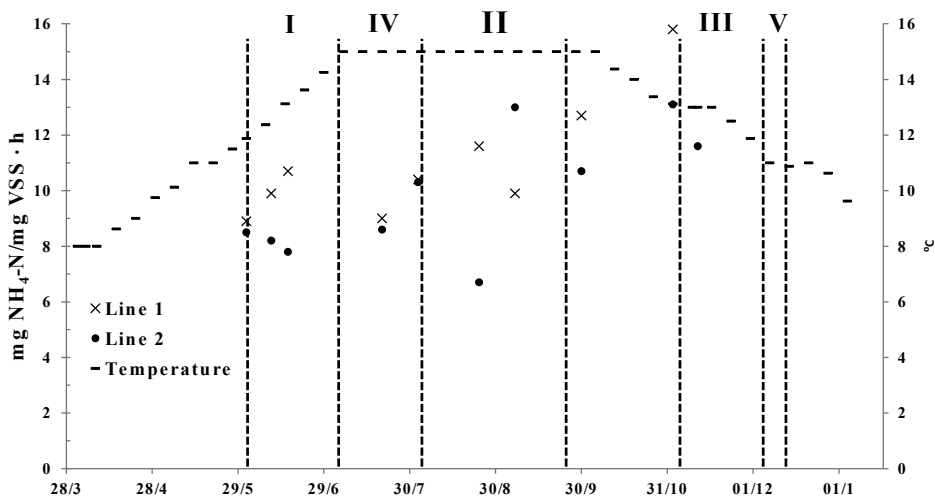

Figure 27
Nitrification rates of line 1 and 2 with wastewater temperature in the primary clarifier during the ozone trial period at Klagshamn WWTP (Paper I). The lines and numerals depict the approximate duration of the ozone treatments.

In the trials for Paper I, both treatment lines were subjected to ozonation with no adverse effect on nitrification rates. The apparent rise in nitrification rates for those lines can be explained by the increase in water temperature. The treatment line that was subjected to ozone at Öresundsverket WWTP (Figure 28) was followed for a shorter time than the treatment line at Klagshamn WWTP. Since the nitrification rate remained stable, no adverse effect on the nitrification rates are attributed to the addition of ozone.

Regarding the other nutrient that is closely followed by WWTP's, the results show no negative impact of ozone on phosphorus release rates (Paper II). Although, the phosphorus removal performance (Bio-P release rate) was only assessed on sludge from Öresundsverket WWTP (Paper II) since Klagshamn WWTP (Paper I) does not employ biological phosphorus removal.

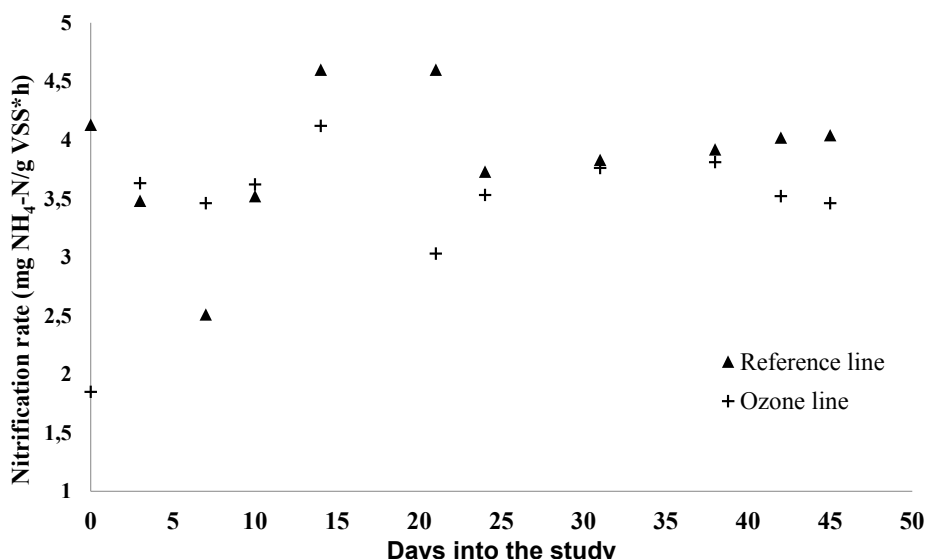

Figure 28
Nitrification rates of the treated ozone and reference lines at Öresundsverket WWTP (Paper II). The ozonation in the ozone line started at day 0.

When ozone was applied to increase the settling speed of the RAS at full scale at Klagshamn WWTP and Öresundsverket WWTP (Papers I and II), the target relative ozone dose was five g O₃/kg SS. However, the achieved relative ozone dose varied substantially (Table 6) due to the varying suspended solids content in the RAS. No pattern was discerned in these variations and they were deemed normal for these plants given the varying load, temperature, and rainfall. Though the achieved relative ozone dose varied greatly, the SVI or DSVI was successfully lowered, which seem to indicate that the applied relative ozone dosage is not the most important factor in this type of ozone application.

Ozone has not been widely used for this application and there are still large knowledge gaps regarding its use in mitigating filamentous bulking sludge. For instance, in the K-I trial, the ozone dosage peaked at 7.7 g O₃/kg SS for a period of 3 days without any detectable adverse effect on the biological nutrient removal processes. However, as demonstrated by Dytczak *et al.* (2007), ozone addition to return activated sludge does have the potential to affect nitrification rates when applied to minimize sludge production. Although no such effects were detected in any of the trials conducted for this thesis, this risk should always be considered when using ozone for filamentous bulking sludge mitigation.

7 Conclusions

Ozone can be used for many different purposes at a WWTP due to its high oxidation potential. The aim of this thesis was to investigate two of these applications: oxidation of pharmaceuticals and filamentous bulking sludge control. Therefore, the conclusions are divided into two sections.

7.1 Ozone and pharmaceuticals

As demonstrated by many researchers in recent years, ozone is a highly effective agent for oxidizing pharmaceuticals in wastewater effluent. However, the same ozone dose will not produce the same results at any WWTP since the concentrations and impact of ozone scavenging compounds in the water matrix varies greatly between WWTPs. Therefore, it is difficult to specify a universal ozone dose that will work at any WWTP. Based on the results obtained for this thesis, a dose of seven g O₃/m³ will result in a total pharmaceutical reduction of approximately 78% in most cases. Furthermore, predicting the level of removal of individual pharmaceuticals based on their reaction constant with ozone was an inaccurate method when compared to pilot-scale results.

One group of ozone-scavenging compounds is organic carbon. The concentration of TOC had a substantial impact on the amount of ozone required to oxidize pharmaceuticals to acceptable levels (>80%). A pre-treatment that lowers the suspended solids (containing organic carbon) prior to ozone addition was highly beneficial in terms of pharmaceutical removal. By lowering the concentration of organic carbon and reducing ozone scavenging, more ozone is available for pharmaceutical removal.

7.2 Ozone and filamentous bulking sludge

Ozone has a clear and significant impact on the important parameter of SVI or DSVI with a relatively low specific dose of approximately five g O₃/kg SS in RAS. The results indicate that there is a large variance in the time required to reach acceptable levels of SVI or DSVI of approximately two to six weeks. In addition, a higher flow of treated RAS decreased the time required to reach acceptable SVI or DSVI levels. As ozone is an oxidant, the necessary biological processes in the WWTP could have been negatively affected. However, no such effect was observed in any of the studied WWTPs (Klagshamn WWTP and Öresundsverket WWTP) even when the desired effect on SVI or DSVI was reached.

One of the goals of this thesis was to track changes in the microbial community of the activated sludge as it was subjected to ozonation at full scale. No change in the microbial species was discerned. However, Live/Dead[®] analyses indicated that the larger surface area of filamentous bacteria makes them more susceptible to ozone attack than bacteria residing within flocs. There also appears to be differences in susceptibility to ozone attack between different filamentous species. For example, type 0041 seems more resistant to ozone than *Microthrix parvicella*. The ozone doses for filamentous bulking sludge do not result in increased methane production and are not sufficient to oxidize micro-pollutants in activated sludge.

8 Future studies

When designing a system for pharmaceutical oxidation with ozone it is important to obtain as much information as possible regarding practical issues. One such issue is the impact of HRT on the effectiveness of pharmaceutical oxidation with ozone. Since the importance of HRT has not been studied in many cases, it would be beneficial to obtain more insight into this area.

Another aspect of pharmaceutical oxidation with ozone that must be considered is the identity and toxicity of the unintended by-products formed when ozone is applied. There have been numerous studies focused on unintended by-products from ozone oxidation. However, there are thousands of different pharmaceutical compounds in use today, and only a small fraction of them have been studied. In addition to studying the by-products, reviewing possible countermeasures of their formation and discharge would be of importance.

Ozone significantly reduces the SVI or DSVI of activated sludge without negatively impacting nutrient removal. The long-term effect on activated sludge microbiology has not been studied, and further investigation into how the microbial community changes over time due to ozone addition is needed.

9 References

- Alleman, J. E. and Prakasam, T. B. S. 1983. Reflections on seven decades of activated sludge history. *Water Pollution Control Federation* 55 (5): 436-443.
- Andreozzi, R., Caprio, V., Marotta, R. and Vogna, D., 2003. Paracetamol oxidation from aqueous solutions by means of ozonation and H₂O₂/UV system. *Water Research* 37 (5): 993-1004.
- Andrzejewski, P., Kasprzyk-Hordern, B. and Nawrocki, J. 2003. N-nitrosodimethylamine (NDMA) formation during ozonation of dimethylamine-containing waters. *Water Research* 42 (4-5): 863-870.
- AWWA Research Foundation, Compagnie Générale des Eaux, Langlais, B., Reckhow, D. A. and Brink, D. R. 1991. *Ozone in water treatment*. Lewis Publishers, Boca Raton.
- Bansal, R. C. and Goyal, M. 2005. *Activated carbon adsorption*. Taylor & Francis. London.
- Benitez, F. J., Acero, J. L., Real, F. J. and Roldán, G. 2009. Ozonation of pharmaceutical compounds: Rate constants and elimination in various water matrices. *Chemosphere* 77 (1): 53-59.
- Benner, J., Salhi, E., Ternes, T. A. and von Gunten, U. 2008. Ozonation of reverse osmosis concentrate: Kinetics and efficiency of beta blocker oxidation. *Water Research* 42 (12): 3003-3012.
- Benner, J. and Ternes, T. A. 2009a. Ozonation of propranolol: Formation of oxidation products. *Environmental Science & Technology* 43 (13): 5086-5093.
- Benner, J. and Ternes, T. A. 2009b. Ozonation of metoprolol: Elucidation of oxidation pathways and major oxidation products. *Environmental Science & Technology* 43 (14): 5472-5480.
- Bin, A. K. and Roustan M. 2000. Mass-transfer in ozone reactors. *International Specialized Symposium IOA 2000. Fundamental and Engineering Concepts for Ozone Reactor Engineering*. Toulouse, March 1-3, Proceedings: 99-131.
- Bougrier, C., Albasi, C., Delgenès, J-P., Carrère, H. 2006. Effect of ultrasonic, thermal and ozone pre-treatments on waste activated sludge solubilization and anaerobic biodegradability. *Chemical Engineering & Processing* 45: 711-718.
- Boulos, L., Prevost, M., Barbeau, B. and Desjardins, R. 1999. Live/Dead[®] BacLight[™]: Application of a new rapid staining method for enumeration of viable and total bacteria in drinking water. *Journal of Microbiological Methods* 37 (1): 77-86.

- Bourgin, M., Beck, B., Boehler, M. Borowska, E., Fleiner, J., Salhi, E., Teichler, R., von Gunten, U., Siegrist, H. and Mc Ardell, C. S. 2017. Evaluation of a full-scale wastewater treatment plant upgraded with ozonation and biological post-treatments: Abatement of micro-pollutants, formation of transformation products and oxidation by-products. *Water Research* (accepted for publication).
- Bourgeois, W., Burgess, J. E. and Stuetz, M. 2001. On-line monitoring of wastewater quality: a review. *Journal of Chemical Technology and Biotechnology* 76 (4): 337-348.
- Borowska, E., Bourgin, M., Hollender, J., Kienle, C., Mc Ardell, C. S. and von Gunten, U. 2016. Oxidation of cetirizine, fexofenadine and hydrochlorothiazide during ozonation: Kinetics and formation of transformation products. *Water Research* 94: 350-362.
- Böhler, M. and Siegrist, H. 2004. Partial ozonation of activated sludge to reduce excess sludge, improve denitrification and control scumming and bulking. *Water Science and Technology* 49 (10): 41-49.
- Camel, V. and Bermond, A. 1998. The use of ozone and associated oxidation processes in drinking water treatment. *Water Research* 32 (11): 3208-3222.
- Carballa, M., Manterola, G., Larrea, L., Ternes, T., Omil, F. and Lema, J. M. 2007. Influence of ozone pre-treatment on sludge anaerobic digestion: Removal of pharmaceutical and personal care product. *Chemosphere* 67: 1444-1452.
- Chu, L., Yan, S., Xing, X.-H., Sun, X. and Jurcik, B. 2009. Progress and perspectives of sludge ozonation as a powerful pretreatment method for minimization of excess sludge production. *Water Research* 43: 1811-1822.
- Chys, M., Demeestere, K., Ingabire, A. S., Dries, J., van Langenhove, H. and van Hulle, S. W. H. 2017. Enhanced treatment of secondary municipal wastewater effluent: comparing (biological) filtration and ozonation in view of micro-pollutant removal, unselective effluent toxicity, and the potential for real-time control. *Water Science & Technology* 76 (1): 236-246.
- Cimbritz, M., Tumlin, S., Hagman, M., Dimitrova, I., Hey, G., Mases, M., Åstrand, N. and la Cour Jansen, J. 2016. Treatment of pharmaceutical residues and other micro-pollutants – a literature survey. Report 2016-04. Svenskt Vatten AB. Stockholm.
- Clara, M., Strenn, B. and Kreuzinger, N. 2004. Carbamazepine as a possible anthropogenic marker in the aquatic environment: investigations on the behavior of Carbamazepine in wastewater treatment and during groundwater infiltration. *Water Research* 38 (4): 947-954.
- Coulson, J. M., Richardson, J. F., Backhurst, J. R. and Harker, J. H. 1999. *Chemical Engineering Volume 1, fluid flow, heat transfer and mass-transfer*. Sixth edition. Butterworth-Heinemann, Oxford.
- Daughton, C. and Ternes, T. A. 1999. Pharmaceuticals and personal care products in the environment: agents of subtle change? *Environmental Health Perspectives* 107 (6): 907-938.
- Dodd, M. C., Buffle, M.-O., von Gunten, U. 2006. Oxidation of antibacterial molecules by aqueous ozone: Moiety-specific reaction kinetics and application to ozone-based wastewater treatment. *Environmental Science & Technology* 40: 1969-1977.

- Dodd, M. C., Koehler, H.-P. E. and von Gunten, U. 2009. Oxidation of antibacterial compounds by ozone and hydroxyl radical: Elimination of biological activity during aqueous ozonation processes. *Environmental Science & Technology* 43 (7): 2498-2504.
- Dytczak, M., Londry, K. L., Siegrist, H. and Oleszkiewicz, J. A. 2007. Ozonation reduces sludge production and improves denitrification. *Water Research* 41: 543-550.
- Eggen, R., L., Hollender, J., Joss, A., Schärer, M. and Stamm, C. 2014. Reducing the discharge of micro-pollutants in the aquatic environment: The benefits of upgrading wastewater treatment plants. *Environmental Science & Technology* 48. 7683-7689.
- Elovitz M. S., von Gunten U. 1999. Hydroxyl radical/ozone ratios during ozonation processes. I. The Rct concept. *Ozone Science & Engineering* 21: 239–260.
- Falås, P., Andersen, H. R., Ledin, A. and la Cour Jansen, J. 2012. Occurrence and reduction of pharmaceuticals in the water phase at Swedish wastewater treatment plants. *Water Science & Technology* 66(4). 783-791.
- Green, D. W. and Perry, R. H. 2008. Perry's chemical engineers' handbook. Eight Edition. McGraw-Hill. New York.
- von Gunten, U. 2003a. Ozonation of drinking water: Part I. Oxidation kinetics and product formation. *Water Research* 37 (7): 1443-1467.
- von Gunten, U. 2003b. Ozonation of drinking water: Part II. Disinfection and by-product formation in presence of bromide, iodide of chlorine. *Water Research* 37 (7): 1469-1487.
- Halling-Sorensen B., Nielsen, S. N., Lanzky, P. F., Ingerslev, F., Lutzhoft Holten, H. C. and Jorgensen, S.E. 1998. Occurrence, fate and effects of pharmaceutical substances in the environment—a review. *Chemosphere* 36: 357–93.
- Hansen, K. M. S., Spiliotopoulou, A., Chhetri, R. K. Casas, M. E., Bester, K. and Andersen, H. R. 2016. Ozonation for source treatment of pharmaceuticals in hospital wastewater – Ozone lifetime and required ozone dose. *Chemical Engineering Journal* 290: 507-514.
- Heyouni, A., Roustan, M. and Do-Quang, Z. 2002. Hydrodynamics and mass-transfer in gas-liquid flow through static mixers. *Chemical Engineering Science* 57: 3325-3333.
- Hoigné, J., Bader H., Haag, W. R., Staehelin J. 1985. Rate constants of reactions of ozone with organic and inorganic compounds in water. III. Inorganic compounds and radicals. *Water Research* 19 (8): 993–1004.
- Hoigné, J., Bader, H. 1994. Characterization of water-quality criteria for ozonation processes Part II: Lifetime of added ozone. *Ozone Science & Engineering* 16 (2): 121-134.
- Hollender, J., Zimmermann, S. G., Koepke, S., Krauss, M., McArdell, C. S., Ort, C., Singer, H., von Gunten, U. and Siegrist, H. 2009. Elimination of organic micro-pollutants in a municipal wastewater treatment plant upgraded with a full-scale post-ozonation followed by sand filtration. *Environmental Science & Technology* 43 (20). 7862-7869.
- Huerta-Fontela, M., Galceran, M. T. and Ventura, F. 2011. Occurrence and removal of pharmaceuticals and hormones through drinking water treatment. *Water Research* 45 (3): 1432-1442.

- Huber, M., C., Canonica, S., Park, G.-Y. and von Gunten, U. 2003. Oxidation of pharmaceuticals during ozonation and advanced oxidation processes. *Environmental Science & Technology* 37 (5): 1016-1024.
- Huber, M. C., Göbel, A., Joss, A., Hermann, N., Löffler, D., McArdell, C. S., Ried, A., Siegrist, H., Ternes, T. A. and von Gunten, U. 2005. Oxidation of pharmaceuticals during ozonation of municipal wastewater effluents: A pilot study. *Environmental Science & Technology* 39 (11): 4290-4299.
- Ibáñez, M., Gracia-Lor, E., Bijlsma, L., Morales, E., Pastor, L. and Hernández, F. 2013. Removal of emerging contaminants in sewage water subjected to advanced oxidation with ozone. *Journal of Hazardous Materials* 260: 389-398.
- Jobling, S., Sheahan, D., Osbourne, J. A., Matthiessen, P. and Sumpter, J. P. 1996. Inhibition of testicular growth in rainbow trout (*Oncorhynchus Mykiss*) exposed to estrogenic alkylphenolic chemicals. *Environmental Toxicology & Chemistry* 15 (2): 194-202.
- Jobling, S., Nolan, M., Tyler, C. R., Brighty, G. and Sumpter, J. P. 1998. Widespread sexual disruption in wild fish. *Environmental Science & Technology* 32 (17): 2498-2506.
- Kim, J.-G., Yousef, A. E. and Dave, S. 1999. Application of ozone for enhancing the microbial safety and quality of foods: A review. *Journal of Food Protection* 62 (9): 1071-1087.
- Kragelund, C., Muller, E., Schade, M., Nguyen, H. T. T., Lemmer, H., Seviour, R. J. and Nielsen, P. H. 2009. *FISH Handbook for biological wastewater treatment*. IWA Publishing, London.
- Klavarioti, M., Mantzavinos, D. and Kassinos, D. 2009. Removal of residual pharmaceuticals from aqueous systems by advanced oxidation processes. *Environment International* 35 (2): 402-417.
- Knopp, G., Prasse, C., Ternes, T. A. and Cormel, P. 2016. Elimination of micro-pollutants and transformation products from a wastewater treatment plant effluent trough pilot scale ozonation followed by various activated carbon and biological filters. *Water Research* 100 (1): 580-592.
- Krauss, M., Longrée, P., Dorusch, F., Ort, C. and Hollender, J. 2009. Occurrence and removal of N-nitrosoamines in wastewater treatment plants. *Water Research* 43 (17): 4381-4391.
- Lee, Y. and von Gunten, U. 2012. Quantitative structure-activity relationships (QSARs) for the transformation of organic micro-pollutants during oxidative water treatment. *Water Research* 46 (19): 6177-6195.
- Lee, Y., Gerrity, D., Lee, M., Bogeat, A. E., Salhi, E., Gamage, S., Trenholm, R. A., Wert, E. C., Snyder, S. A. and von Gunten, U. 2013. Prediction of micro-pollutant elimination during ozonation of municipal wastewater effluents: Use of kinetics and water specific information. *Environmental Science & Technology* 47 (11): 5872-5881.
- Lee, Y., Imminger, S., Czekalski, N., von Gunten, U. and Hammes, F. 2016. Inactivation of *Escherichia coli* and autochthonous bacteria during ozonation of municipal wastewater effluents quantified with flow cytometry and adenosine tri-phosphate analyses. *Water Research* 101: 617-627.
- van Leeuwen, J. 1988. Bulking control with ozonation in a nutrient removal activated sludge system. *Water SA* 14 (3): 119-124.

- van Leeuwen, J. & Pretorius, W. A. 1988. Sludge bulking control with ozone. *Journal of the Institution of Water and Environmental Management* 2 (2): 223-227.
- van Leeuwen, J. 1992. A review of the potential application of non-specific activated sludge bulking control. *Water SA* 18 (2): 101-106.
- Levén, L., Wijnbladh, E., Tuveesson, M., Kragelund, C. and Hallin, S. 2016. Control of *Microthrix parvicella* and sludge bulking by ozone in a full-scale WWTP. *Water Science & Technology* 73 (4): 866-872.
- Lyko, S., Teichgräber, B. and Kraft, A. 2012. Bulking control by low-dose ozonation of returned activated sludge in a full-scale wastewater treatment plant. *Water Science & Technology* 65 (9): 1654-1659.
- Länge, R., Hutchinsonson, T. H., Croudace, C. P. and Siegmund, F. 2001. Effects of the synthetic estrogen 17 α -ethinylestradiol on the life-cycle of the Fathead Minnow (*Pimephales Promelas*). *Environmental Toxicology & Chemistry* 20 (6): 1216-1227.
- Martin, N. and Galey, C. 1994. Use of static mixer for oxidation and disinfection by ozone. *Ozone Science & Engineering* 16 (4): 455-473.
- Martins, A. M. P., Pagilla, K., Heijnen, J. J. and van Loosdrecht, M. C. M. 2004. Filamentous bulking sludge – a critical review. *Water Research* 38 (4): 793-817.
- Matsui, S., Yamamoto, H., Shimizu, Y., Harada, J. and Einaga, D. 1998. Humic substances affecting the limitation of the activated sludge process removal of micro-pollutants. *Water Science & Technology* 38 (7): 217-225.
- Margot, J., Kienle, C., Magnet, A., Weil, M., Rossi, L., de Alencastro, L. F., Abegglen, C., Thonney, D., Chèvre, N., Schärer, M. and Barry, D. A. 2013. Treatment of micro-pollutants in municipal wastewater: Ozone of powdered activated carbon? *Science of the Total Environment* 461-462: 480-498.
- McDowell, D. C., Huber, M. C., Wagner, M., von Gunten, U. and Ternes, T. A. 2005. Ozonation of carbamazepine in drinking water: Identification and kinetic study of major oxidation products. *Environmental Science & Technology* 39 (20): 8014-8022.
- Mulder, M., Antakyali, D., Ante, S. 2015. Costs of removal of micro-pollutants from effluents of municipal wastewater treatment Plants – general cost estimates for the Netherlands based on implemented full scale post treatments of effluents of wastewater treatment plants in Germany and Switzerland. STOWA and Waterboard the Dommel, Netherlands.
- Najjar, N. H. E., Touffet, A., Deborde, M., Journel, R. and Leitner, N. K. V. 2014. Kinetics of paracetamol oxidation by ozone and hydroxyl radicals, formation of transformation products and toxicity. *Separation and Purification Technology* 136: 137-143.
- Nakada, N., Shinohara, H., Murata, A., Kiri, K., Managaki, S., Sato, N. and Takada, H. 2007. Removal of selected pharmaceuticals and personal care products (PPCPs) and endocrine-disrupting chemicals (EDCs) during sand filtration and ozonation at a municipal sewage treatment plant. *Water Research* 41 (19): 4373-4382.
- Nilsson, F. 2015. Application of ozone in wastewater treatment – For mitigation of filamentous bulking sludge and reduction of pharmaceutical discharge. Media Tryck, Lund. ISBN 978-91-7422-424-5.
- Richardson, S. D. 2003. Disinfection by-products and other emerging contaminants in drinking water. *Trends in Analytical Chemistry* 22 (10): 666-684.

- Paris, S., Lind, G., Lemmer, H. and Wilderer, P. A. 2005. Dosing aluminium chloride to control *Microthrix parvicella*. *Acta hydrochimica et hydrobiologica* 33 (3): 247-254.
- Real, F. J., Benitez, F. J., Acero, J. L., Sagasti, J. J. P. and Casas, F. 2009. Kinetics of the chemical oxidation of the pharmaceuticals primidone, ketoprofen, and diatrizoate in ultrapure and natural waters. *Industrial & Engineering Chemistry Research* 48 (7): 3380-3388.
- Rivas, J., Gimeno, O., Encinas, A. and Beltrán, F. 2009. Ozonation of the pharmaceutical ranitidine: Reactivity and kinetic aspects. *Chemosphere* 76: 651-656.
- Rubin, M. B. 2001. The history of ozone. The Schönbein period 1839-1868. *Bulletin for the history of chemistry* 26 (1): 40-56.
- Santos, L. H. M. L. M., Araújo, A. N., Fachini, A. Pena, A., Delerue-Matos, C. and Montenegro, M. C. B. S. M. 2010. Ecotoxicological aspects related to the presence of pharmaceuticals in the aquatic environment. *Journal of Hazardous Materials* 175: 45-95.
- Saayman, G. B., Schutte, G. B. and van Leeuwen, J. 1996. The effect of chemical bulking control on biological nutrient removal in a full scale activated sludge plant. *Water Science & Technology* 34 (3-4): 275-282.
- Saayman, G. B., Schutte, G. B. and van Leeuwen, J. 1998. Chemical control of filamentous sludge bulking in a full-scale biological nutrient removal activated sludge plant. *Ozone Science & Engineering* 20 (1): 1-15.
- Schaar, H., Clara, M., Gans, O. and Kreuzinger, N. 2010. Micro-pollutant removal during biological wastewater treatment and a subsequent ozonation step. *Environmental Pollution* 158 (5): 1399-1404.
- Sehlén, R. 2017. Telephone interview conducted on the 24th of August 2017.
- Sein, M.M., Zedda, M., Tuerk, J., Schmidt, T.C., Golloch, A. and von Sonntag, C. 2008. Oxidation of diclofenac with ozone in aqueous solution. *Environmental Science & Technology* 42 (17): 6656-6662.
- Soltermann, F., Abegglen, C., Tschui, M., Stahel, S. and von Gunten, U. 2017. Options and limitations for bromate control during ozonation of wastewater. *Water Research* 116 (1): 76-85.
- Stalter, D., Magdeburg, A., Weil, M., Knacker, T. and Oehlmann, J. 2010a. Toxication or detoxication? *In vivo* toxicity assessment of ozonation as advanced wastewater treatment with the rainbow trout. *Water Research* 44 (2): 439-448.
- Stalter, D., Magdeburg, A. and Oehlmann, J. 2010b. Comparative toxicity assessment of ozone and activated carbon treated sewage effluents using an *in vivo* test battery. *Water Research* 44 (8): 2610-2620.
- Stapf, M., Miehe, U. and Jekel, M. 2016. Application of online UV absorption measurements for ozone process control in secondary effluent with variable nitrite concentration. *Water Research* 104 (1): 111-118.
- Sumpter, J. P. 1995. Feminized responses in fish to environmental estrogens. *Toxicology Letters* 82/83: 737-747.
- Swedish EPA. 2016. Wastewater. ISBN 978-91-620-8730-2.

- Ternes, T. A. 1998. Occurrence of drugs in German sewage treatment plants and rivers. *Water Research* 32 (11): 3245-3260.
- Ternes, T. A., Joss, A. and Siegrist, H. 2004. Scrutinizing pharmaceuticals and personal care products in wastewater treatment. *Environmental Science & Technology* 38 (20): 392A-299A.
- UN, United Nations Statistics Division. 2011. Inland water resources: Wastewater. <https://unstats.un.org/unsd/environment/wastewater.htm> (accessed 2017-11-20).
- USEPA, 1998. National primary drinking water regulations: disinfectants and disinfection by-products final rule. *Fed. Reg.* 63(241), 69389.
- Vanrolleghem, P. A. and Lee, D. S. 2003. On-line monitoring equipment for wastewater treatment processes: state of the art. *Water Science & Technology* 47 (2): 1-34.
- Venturi, G. B. 1826. Experimental inquiries concerning the principle of the lateral communication of motion in fluids, translation by W. Nicholson, *Tracts on Hydraulics*, 2nd edition. J. Taylor. London.
- Wahlberg, C., Björlenius, B., Paxéus, N. (2010). *Läkemedelsrester i Stockholms vattenmiljö*. Slutrapport, Stockholm Vatten, ISBN 978-91-633-6642-0.
- Watson, K., Farré, M. J. and Knight, N. 2012. Strategies for the removal of halides from drinking water sources, and their applicability in disinfection by-product minimization: A critical review. *Journal of Environmental Management* 110: 276-298.
- Weemaes, M., Grootaerd, H., Simoens, F. and Verstraete, W. 2000. Anaerobic digestion of ozonized biosolids. *Water Research* 34: 2330-2336.
- Wennberg, M., Nyberg, U., Mante, J., Rydén, M. and Jönsson, K. 2009. Decreasing filamentous growth using aluminium-based chemical and ozone at Klagshamn wastewater treatment plant. Paper presented at 2nd IWA Specialized Conference Nutrient Management in Wastewater Treatment Processes, Krakow, September 6-9.
- Wert, E. C., Rosario-Ortiz, F., Drury, D. D. and Snyder, S. A. 2007. Formation of oxidation by-products from ozonation of wastewater. *Water Research* 41 (7): 1481-1490.
- Wert, E. C., Rosario-Ortiz, F. L. and Snyder, S. A. 2009. Effect of ozone exposure on the oxidation of trace organic contaminants in wastewater. *Water Research* 43: 1005-1014.
- Wildhaber, Y. S., Mestankova, H., Schärer, M., Schirmer, K., Salhi, E. and von Gunten, U. 2015. Novel test procedure to evaluate the treatability of wastewater with ozone. *Water Research* 75: 324-335.
- Xu, P., Janexb, M-L., Savoyeb, P., Cockxc, A. and Lazarovab, V. 2002. Wastewater disinfection by ozone: main parameters for process design. *Water Research* 36 (4): 1043-1055.
- Yamamoto, H., Nakamura, Y., Moriguchi, S., Nakamura, Y., Honda, Y., Tamura, I., Hirata, Y., Hayashi, A. and Sekizawa, J. 2009. Persistence and partitioning of eight selected pharmaceuticals in the aquatic environment: Laboratory photolysis, biodegradation and sorption experiments. *Water Research* 43 (2): 351-362.
- Yasui, H., Nakamura, K., Sakuma, S., Iwasaki, M. and Sakai, Y. 1996. A full-scale operation of a novel activated sludge process without excess sludge production. *Water Science and Technology* 34 (3-4): 395-404.

Zimmermann, S. G., Wittenwiler, M., Hollender, J., Krauss, M., Ort, C., Siegrist, H. and von Gunten, U. 2011. Kinetic assesment and modeling of an ozonation step for full-scale municipal wastewater treatment: Micro-pollutant oxidation, by-product formation and disinfection. *Water Research* 45 (2): 605-617.



My name is Filip Nilsson and I am an engineer and scientist. I have been employed as an industrial Ph.D. student and process engineer at Primozone Production AB since 2010 and have been working with ozone and its applications ever since.

My research has been focused on applying ozone in wastewater treatment to increase the effectiveness of the current treatment process. I have almost exclusively been working with full- or pilot-scale installations of ozone in an effort to obtain experimental data that can be applied in wastewater treatment as straightforwardly as possible.