



LUND UNIVERSITY

Evaluation of a Probing Feeding Strategy in Large Scale Cultivations

Velut, Stéphane; de Maré, Lena; Axelsson, Jan Peter; Hagander, Per

2002

Document Version:

Publisher's PDF, also known as Version of record

[Link to publication](#)

Citation for published version (APA):

Velut, S., de Maré, L., Axelsson, J. P., & Hagander, P. (2002). *Evaluation of a Probing Feeding Strategy in Large Scale Cultivations*. (Technical Reports TFRT-7601). Department of Automatic Control, Lund Institute of Technology (LTH).

Total number of authors:

4

General rights

Unless other specific re-use rights are stated the following general rights apply:

Copyright and moral rights for the publications made accessible in the public portal are retained by the authors and/or other copyright owners and it is a condition of accessing publications that users recognise and abide by the legal requirements associated with these rights.

- Users may download and print one copy of any publication from the public portal for the purpose of private study or research.
- You may not further distribute the material or use it for any profit-making activity or commercial gain
- You may freely distribute the URL identifying the publication in the public portal

Read more about Creative commons licenses: <https://creativecommons.org/licenses/>

Take down policy

If you believe that this document breaches copyright please contact us providing details, and we will remove access to the work immediately and investigate your claim.

LUND UNIVERSITY

PO Box 117
221 00 Lund
+46 46-222 00 00

ISSN 0280-5316
ISRN LUTFD2/TFRT--7601--SE

Evaluation of a probing feeding strategy in large scale cultivations

Stéphane Velut
Lena de Maré
Jan Peter Axelsson
Per Hagander

Department of Automatic Control
Lund Institute of Technology
April 2002

Department of Automatic Control Lund Institute of Technology Box 118 SE-221 00 Lund Sweden	<i>Document name</i> Internal report	
	<i>Date of issue</i> April 2002	
	<i>Document Number</i> ISRN LUTFD2/TFRT--7601--SE	
<i>Author(s)</i> Stéphane Velut, Lena de Maré, Jan Peter Axelson, Per Hagander	<i>Supervisor</i> Per Hagander	
	<i>Sponsoring organisation</i> Vinnova, Pharmacia AB	
<i>Title and subtitle</i> Evaluation of a probing feeding strategy in large scale cultivations (Utvärdering av en substratdosering strategi i storskaliga odlingar)		
<i>Abstract</i> <p>This report presents the results of two <i>Escherichia coli</i> cultivations performed in a large scale industrial bioreactor. The experiments aimed at evaluating a probing feeding strategy that addresses the problem of acetate accumulation. The principle is to superimpose short pulses in the glucose feed and evaluate the response in the dissolved oxygen signal for the feed adjustments. Simulations of a two compartments system are also done to give insight into the possible effects of the scale and the imperfect mixing on the feeding strategy. Satisfactory results in terms of recombinant protein amounts have been obtained and no major adverse large scale effects were observed.</p>		
<i>Key words</i> Fed-batch cultivation, large scale, <i>Escherichia coli</i> , glucose feeding, acetate, dissolved oxygen, recombinant protein production.		
<i>Classification system and/ or index terms (if any)</i>		
<i>Supplementary bibliographical information</i>		
<i>ISSN and key title</i> 0280-5316		<i>ISBN</i>
<i>Language</i> English	<i>Number of pages</i> 20	<i>Recipient's notes</i>
<i>Security classification</i>		

The report may be ordered from the Department of Automatic Control or borrowed through:
 University Library 2, Box 3, SE-221 00 Lund, Sweden
 Fax +46 46 222 44 22 E-mail ub2@ub2.lu.se

Contents

1. Introduction	2
2. Cultivation procedure and material	2
3. Feeding strategy	2
4. Auxiliary control loops	3
4.1 Feed flow control system	3
4.2 Dissolved oxygen control	4
5. Results and discussion	5
5.1 Cultivation 1	5
5.2 Cultivation 2	5
5.3 Discussion	6
5.4 Simulations of a two compartments system	11
6. Conclusion	13
7. Acknowledgment	13
8. References	14
A. Cultivation 1	15
B. Cultivation 2	16
C. Feedback algorithm	17
D. Parameters value	18
E. Future experiments	19

1. Introduction

This report gives an account of two experiments aiming at evaluating the feeding strategy in [5] in large scale cultivations. The probing strategy has been developed and tested in laboratory scale bioreactors where good performances were achieved. Therefore it was interesting to test the control principle at an industrial scale. For this purpose two cultivations have been performed at Pharmacia, Strängnäs. The main difficulties encountered when scaling-up a process are normally related to the mixing problems. Presence of gradients in the substrate and oxygen concentrations may have serious effects on the probing feeding strategy.

The aim of the experiments is to test the pulse programme and compare its performance with the fixed profiles. Simulations of a two compartments system will also be performed to give an insight of the possible effects of the scale on the probing strategy.

2. Cultivation procedure and material

Fed-batch cultivations have been performed in a 12 m^3 reactor using a recombinant *Escherichia coli* strain. The production of the recombinant product was induced by a chemical agent. The media used was defined and thus contained no complex compounds like yeast extract or casein. The initial volume after inoculation was 3500 l with an initial glucose concentration of 15 g/l . During the fed-batch phase, the feed had a glucose concentration of 600 g/l , and was added according to the feeding strategy. The pH was kept at 7.0 by addition of ammonia. The temperature was regulated at 30°C until induction where it was increased up to 37°C within a few minutes. The dissolved oxygen was kept above limiting concentrations most of the time. The air flow rate was $260\text{ m}^3/\text{h}$ and the pressure was stepwise increased to reach 1.1 bar overpressure before induction.

The dissolved oxygen concentration was monitored by a polarographic oxygen electrode at the bottom of the tank and controlled by varying the stirrer speed in the range 50-130 *rpm*. The exhaust gas was analysed using a gasanalyser with a paramagnetic cell for oxygen measurement and infrared for carbon dioxide measurement. Conventional reactor control and data logging was made by SattCon31-90 together with SattGraph1200 control systems. The probing-control algorithm was also implemented in the SattCon system.

3. Feeding strategy

The feed flow rate is controlled by the probing feeding strategy described in [5], [6] and [7]. The strategy addresses the problem of acetate accumulation, which inhibits both growth and product formation. The key idea is to exploit the characteristic saturation in the respiratory system that occurs at the onset of acetate formation, when the glucose uptake rate q_g exceeds q_g^{crit} . The saturation can be detected by superimposing up pulses to the feed rate and observing the response in the dissolved oxygen signal. The

feed rate adjustment after a pulse is computed by the probing controller as shown in Figure 1.

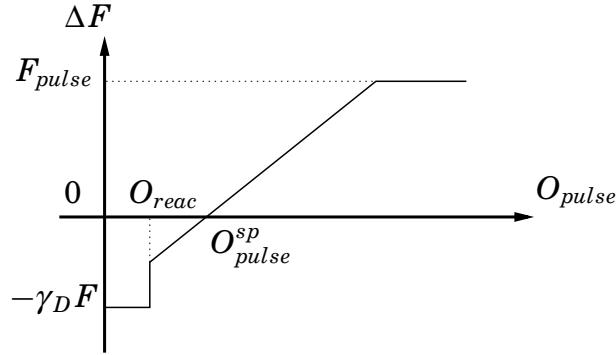

Figure 1 Feed rate adjustment of the probing controller without integral action. When the pulse response is above O_{reac} , the feed adjustment is proportional to $O_{pulse} - O_{pulse}^{sp}$ but cannot exceed the size of a feed pulse. If O_{pulse} is below O_{reac} , it is concluded that q_g is greater than q_g^{crit} and the feed rate is decreased.

Between two pulses the dissolved oxygen tension is controlled using the agitation speed. This guarantees aerobic conditions and ensures that the oxygen level has the same value at every pulse start. The block diagram of the closed-loop system is shown in Figure 2.

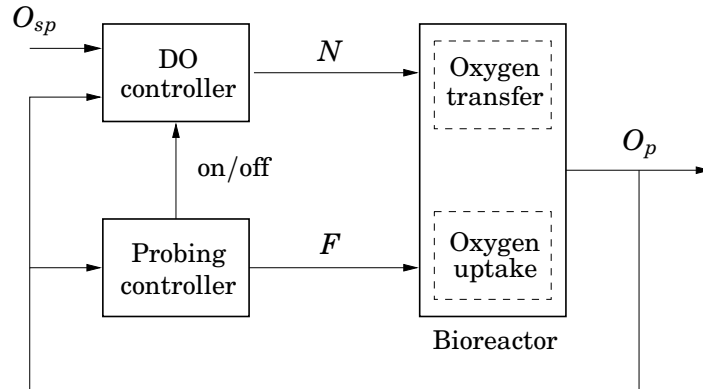

Figure 2 Block diagram of the closed-loop system. The probing controller turns off the dissolved oxygen controller so that the stirrer speed N is kept constant during the pulses in F .

The feedback algorithm that adjusts the feed rate and the stirrer speed using the dissolved oxygen signal is given in Appendix C with the parameters in Appendix D.

4. Auxiliary control loops

4.1 Feed flow control system

The probing feeding strategy requires a good control of the glucose flow entering the bioreactor. Exact dosing and fast setpoint following are essential conditions in order to perform short pulses in the feed rate. For this

purpose a controller manipulating the feed rate and using on-line measurement of the feed flow has been used. Figure 3 shows the performance achieved when the PI-controller was tuned. It was tuned for fast response to set-point changes still maintaining sufficient stability margin. After the tuning phase the pulse length was fixed at 3 minutes. In the SattCon system the set-point signal affects the controller output through the integral term and no part through the proportional term (i.e. $\beta = 0$ see [1]). The set-point tracking problem has therefore been tuned by changing the integral time only.

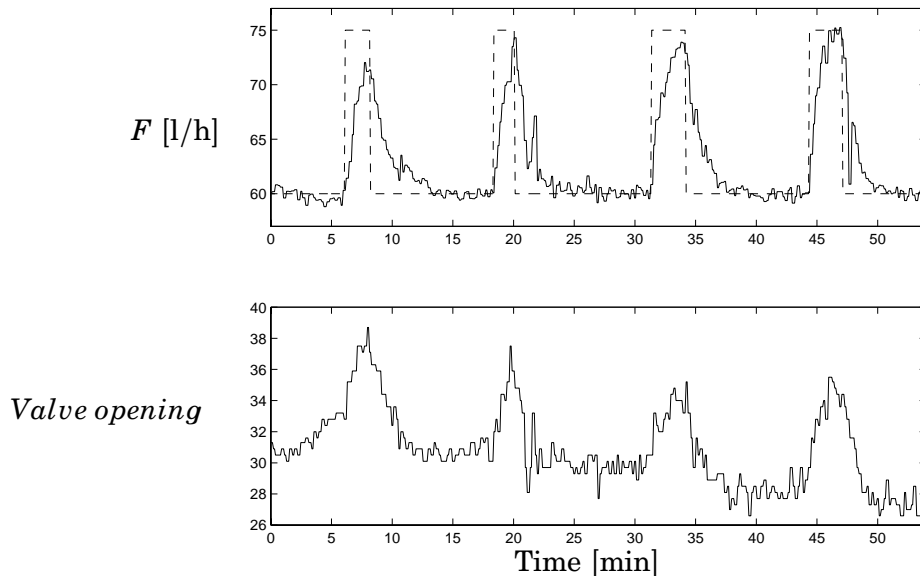

Figure 3 Cultivation 1, 20 h 15 min. The parameters of feed flow controller have been changed from $K = 1$, $T_i = 50$ s to $K = 2$, $T_i = 50$ s at $t = 12$ min and finally to $K = 1.5$, $T_i = 35$ s at $t = 42$ min. The two first pulses have length 2 min and 1.6 min whereas the last two pulses are 3 minutes long.

In order to get good performances in spite of process variations, one had to adjust the controller parameters in the course of experiments. The parameters have been changed at $t = 23$ h 10 min and at $t = 02$ h 53 min in the first cultivation while no modification were done in the second experiment.

4.2 Dissolved oxygen control

The dissolved oxygen signal is the only information used by the probing strategy to adjust the feed rate. It is therefore important to control the dissolved oxygen so it quickly recovers back to the setpoint after each pulse. A SattCon PI controller has been used to maintain the dissolved oxygen tension at the desired level by manipulating the agitation speed. During the feed pulses the controller is turned off and the stirrer speed is maintained fixed in order not to interfere with the pulse response.

To get good performances throughout the cultivation, one had to adjust manually the parameters of the controller. The integral time was typically increased to reduce the oscillations occurring at low stirrer speeds, see Figure 4. The manual adjustments correspond in fact to a gain scheduling from the stirrer speed.

The large variations in the pressure and the temperature during the cultivation also affect the oxygen dynamics and, as a consequence, the per-

formance of the controller. It should also be pointed out that the high temperature sensitivity of the oxygen probe may be a source of measurement errors. The calibration was carried out at 30°C whereas the temperature was set to 37°C after induction.

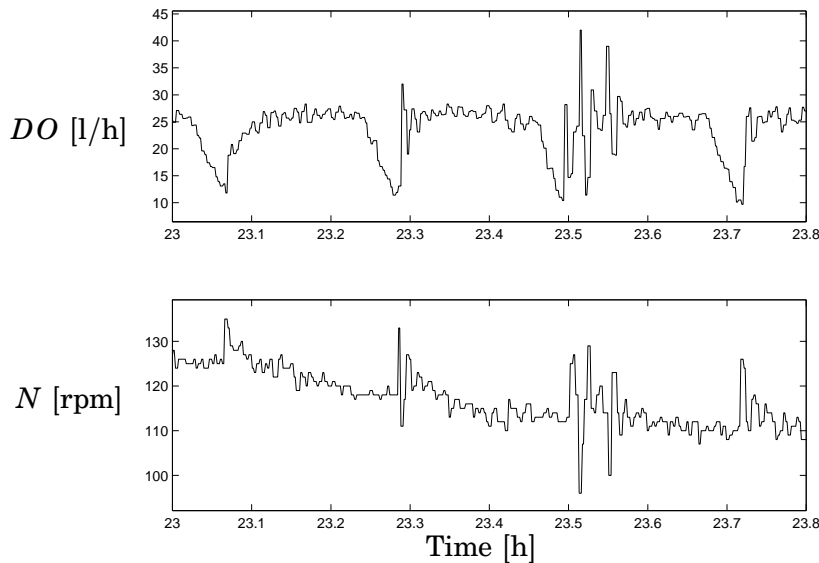

Figure 4 Response to superimposed feed pulses in cultivation 1. The integral time T_i has been changed from 100 s to 130 s at time $t = 23.65h$.

5. Results and discussion

Two similar cultivations have been performed to test the feeding strategy. In both experiments the pulse programme has been turned off before induction in order to increase manually the pressure and the temperature.

5.1 Cultivation 1

The experiment results are shown in Figure 5 and in Appendix A. The pulse programme was activated when a good controller for the dissolved oxygen was available. A predetermined profile was applied until $t = 25 h$ and pulses superimposed to the feed rate from the end of exponential phase at $t = 20 h$. No signs of overfeeding could be observed in the dissolved oxygen signal. Production of the recombinant protein was induced at time $t = 22 h$. After the activation of the pulse programme at $t = 25 h$ the feed rate was increased from $55 l/h$ to $75 l/h$ by the controller until the maximum stirrer speed was reached. In the later part of the cultivation the safety net in the controller adjusted the feed rate to avoid anaerobic conditions.

5.2 Cultivation 2

The experiment results are shown in Figure 6 and in Appendix B. The feed rate remained approximately constant after the feed start and pulses were superimposed. After stabilization of the dissolved oxygen tension at 40%, the feeding strategy started to increase the feed rate. At time $t = 19 h$, the stirrer speed reached its maximum value and no feed increment was

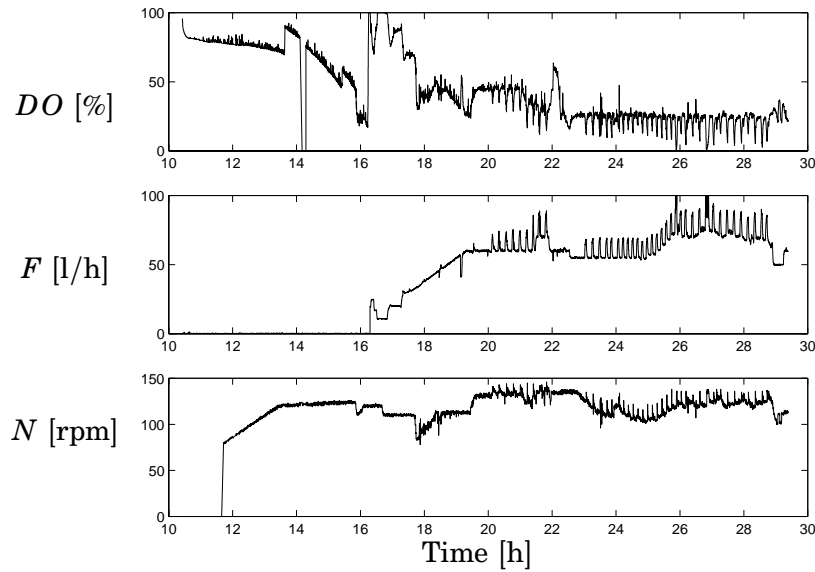

Figure 5 First cultivation 2000-11-26.

allowed. From $t = 21 \text{ h}$ to 22 h the feed flow rate has been manually decreased in order to perform induction at a feed flow level corresponding to standard praxis. Induction of the recombinant protein occurred at time $t = 22 \text{ h}$. The pulse programme, reactivated at $t = 23 \text{ h}$ without feed increment, decreased the feed rate once when no pulse response was observed. After $t = 24 \text{ h}$, the feeding strategy increased the feed rate again until the maximum stirrer was reached.

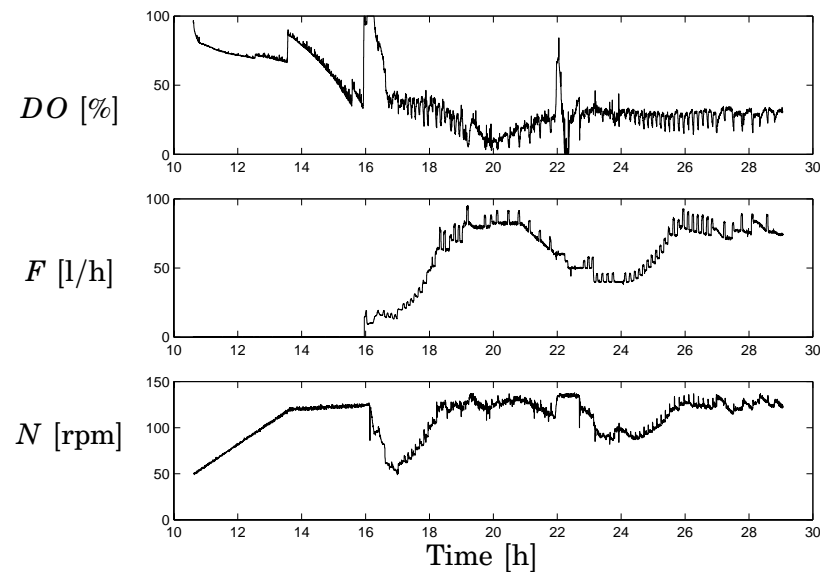

Figure 6 Second cultivation 2000-12-07.

5.3 Discussion

Satisfactory results have been obtained with the feeding strategy. Both cultivations gave an amount of recombinant protein that was about the same as for the fixed profiles.

The first experiment made it possible to test the performance of the feed profile. The pulses that have been superimposed suggest that glucose

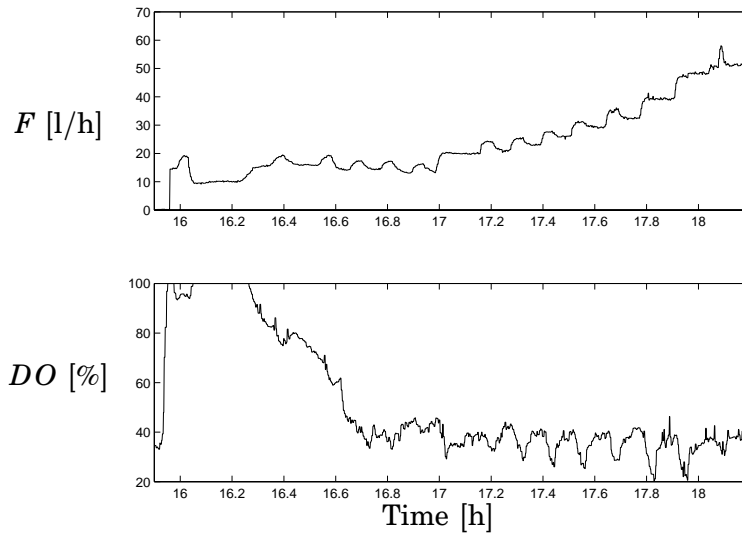

Figure 7 Exponential phase of the second cultivation.

did not accumulate. The increase in the feed rate at the activation of the probing strategy indicates however that the fixed profile did not use the full capacity of the reactor. The control algorithm tends indeed to maximize the feed rate with respect to constraints in terms of cell metabolism and mass transfer. Figure 7 shows the exponential phase of the second cultivation. After stabilization of the DOT value, the feeding strategy increased the feed rate, and the maximum stirrer speed was reached before any overflow metabolism could be seen in the pulse responses. The fast increase in the feed flow, which would correspond to a growth rate of $\mu = 0.75 \text{ h}^{-1}$, indicates that the starting feed flow was rather low. Simple calculations based on the initial amount of glucose and the yield coefficient Y_{xg} suggest an initial feed rate of 25 l/h instead of 10 l/h .

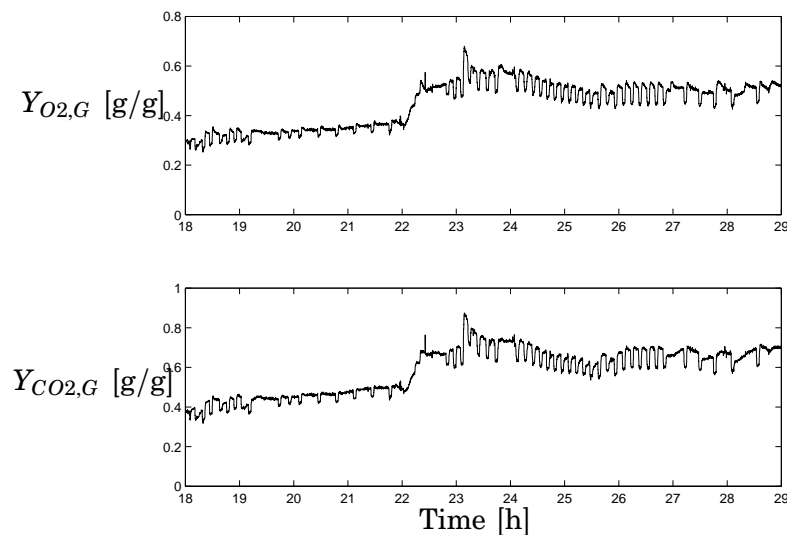

Figure 8 Yields coefficients $Y_{O_2,G}$ and $Y_{CO_2,G}$ in the second cultivation.

The main limitation in both cultivations was the oxygen transfer capacity of the reactor. Although the pressure was increased a few times to get a higher oxygen transfer, the agitation speed remained close to its maximum value most of the time. Figure 8 where the instantaneous yield

coefficients $Y_{O_2,G}$ and $Y_{CO_2,G}$ are shown, confirms the increased demand of oxygen during the production phase. The instantaneous yield coefficient is defined as the ratio between the consumption rates. The higher yield coefficients after the induction time $t = 22$ h reveal a higher respiration when the protein is produced.

In addition to the increased respiratory activity, the oxygen transfer decreased at every antifoam addition, causing the saturation of the agitation speed. Figure 9 illustrates the need for the safety net that avoids anaerobic conditions due to the limitation of the reactor oxygen transfer. The antifoam addition at $t = 26.97$ h provoked a fast decrease in the DO level and as a consequence the saturation of the stirrer speed. In order to get the oxygen level back to the setpoint 30% the feed rate was decreased linearly as long as the stirrer speed was above $N_{high2} = 128$ rpm.

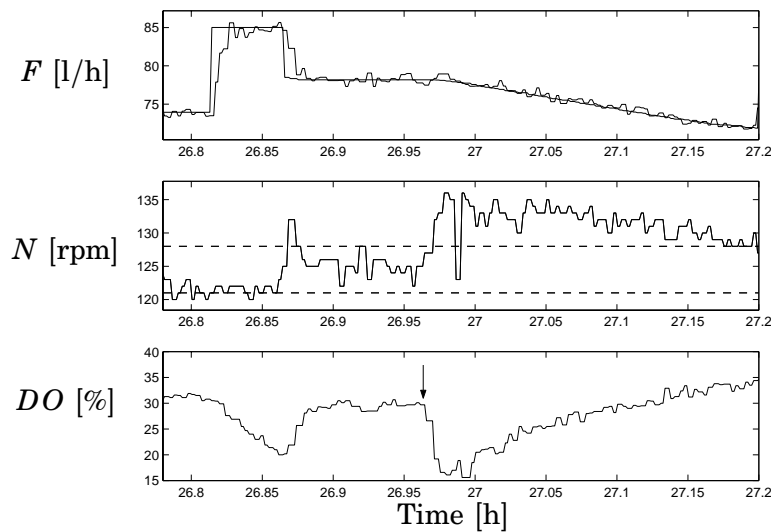

Figure 9 Antifoam addition at time 26.97 h in the Cultivation 2.

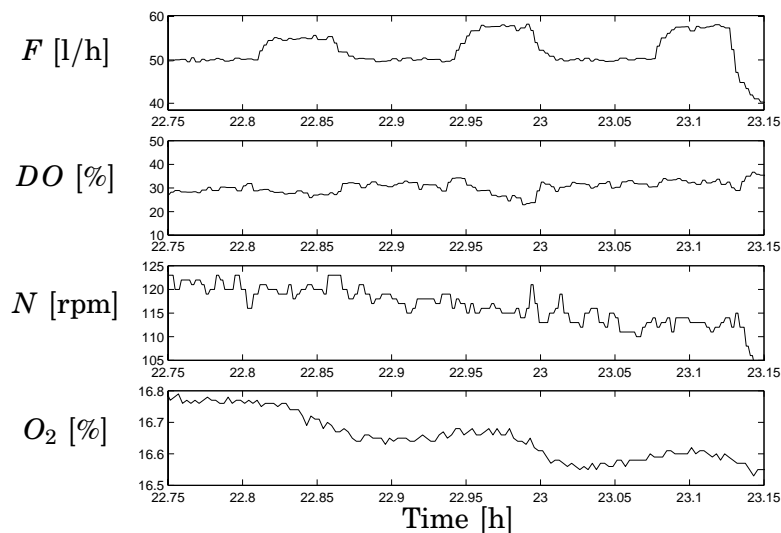

Figure 10 Post-induction phase of the second experiment.

Figure 10 shows a continuous decrease in the agitation speed at the

activation of the DOT strategy after induction. Since the feed rate and the dissolved oxygen concentration are constant during this period, this could be explained by an improvement of the oxygen transfer to the cells. This result contrasts with the decrease in the oxygen transfer rate that is expected after induction because of the cell lysis, see [4]. The behavior of the pulse programme should not be altered by this oxygen transfer change. However a lower stirrer speed affects the performance of the DOT-controller negatively similarly to what was shown in Figure 4.

Limitations from the metabolism could be observed in the pulse responses after induction. According to [5], the amplitude of the oxygen response to a feed pulse is given at steady state by

$$\Delta O = -\frac{\beta}{1+\alpha} \cdot \frac{O^* - O_{sp}}{F} \Delta F$$

where $\beta < 1$ takes into account the process dynamics and $\alpha \approx 0$ except when acetate is consumed or for low glucose uptake rates.

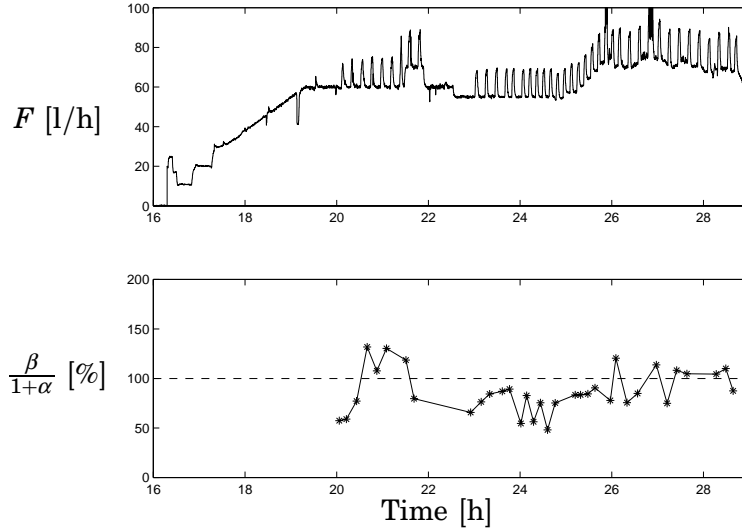

Figure 11 Normalized pulse responses in the first cultivation.

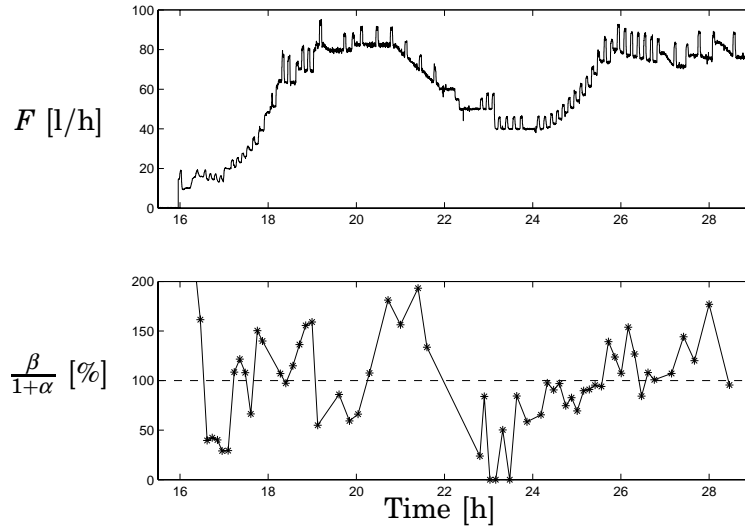

Figure 12 Normalized pulse responses in the second cultivation.

The factor $\frac{\Delta O}{O^* - O_{sp}} \frac{F}{\Delta F} = \frac{\beta}{1 + \alpha}$ can then tell us whether there is glucose accumulation or not. The values taken by this factor are clearly lower than 1 at two stages, just after the activation of the pulse programme and during the post-induction phase, see Figures 11 and 12.

The small oxygen responses observed at $t = 20$ h in Figure 11 and at $t = 16$ h30 in Figure 12 actually related to the unsteady character of that cultivation stage: the oxygen level was not stabilized at the setpoint 40 % and furthermore, the feed flow controller was not well-tuned. The absence of well-tuned controllers rather than the glucose level was the origin of the small oxygen responses during this period. During the post-induction phase of the second cultivation, see Figure 12 for $t \in [23$ h, 24 h], glucose accumulation may have caused the small pulse responses. It has been reported that the critical glucose concentration, above which the oxygen uptake saturates, decreases after induction, see for instance [8]. This saturation has probably been approached when no pulse response could be seen in the dissolved oxygen signal. The decrease in the feed rate before induction did apparently not suffice to prevent overfeeding.

Analysis of the outgas can help us in the interpretation of the feed pulses. The oxygen concentration in the outgas is clearly affected by the variations in the feed rate, see Figure 13. The dissolved oxygen tension as well as the oxygen concentration in the outgas can be used to detect the onset of acetate formation.

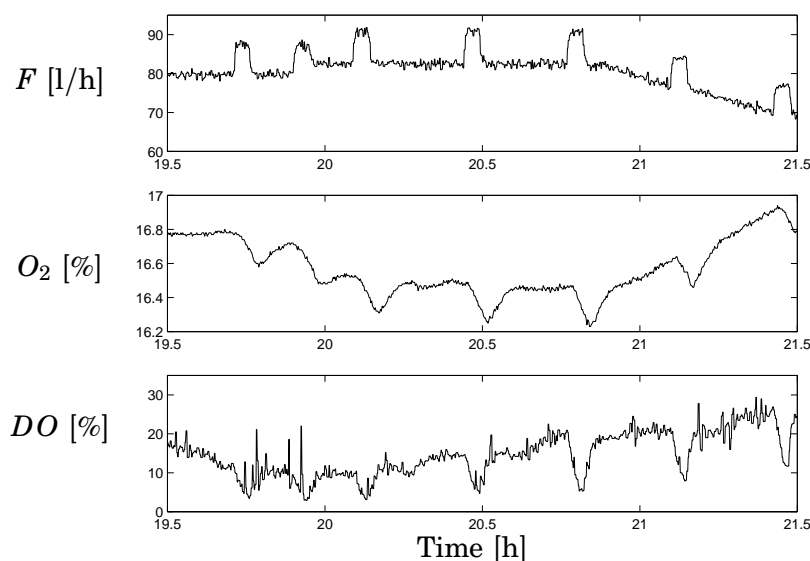

Figure 13 Pulse responses from the second experiment in the outgas and the dissolved oxygen signal. Note that the DO-setpoint was decreased to 20% from $t = 19.5$ h to $t = 20.2$ h.

Figure 14 shows the post-induction phase of the second cultivation, a period where the pulse responses were small. As the feed rate was supposed to be at a constant level corresponding to standard praxis, the proportional controller was not activated, i.e $\gamma = 0$. The large decrease from 50 l/h to 40 l/h would have certainly not occurred if the feeding controller was active. Small successive adjustments of the feed rate would have been done instead of a large one.

The local fluctuations of the dissolved oxygen concentration make it

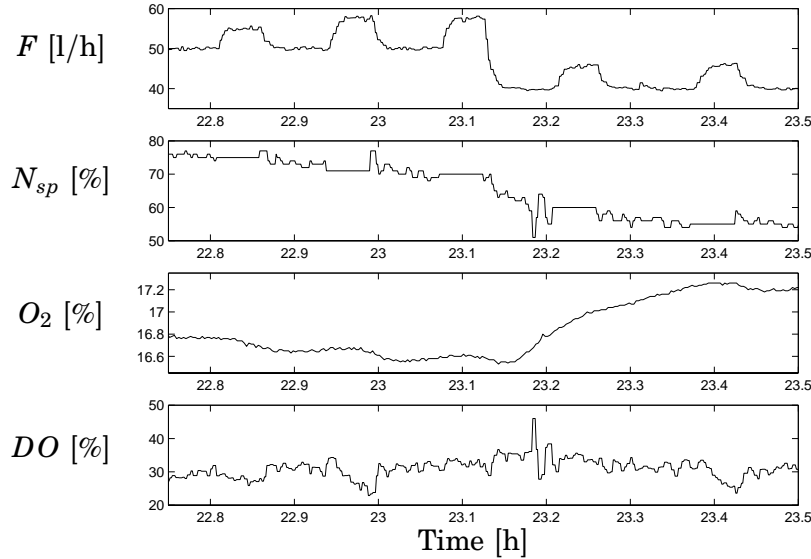

Figure 14 Post-induction phase of the second experiment. No feed increment was allowed under this period ($\gamma = 0$). The absence of pulse response, i.e. response below O_{rec} , at $t = 23.15$ h caused however a decrease in the feed ($\gamma D = 20\%$).

difficult to discern the small responses. It is easier in that case to see the pulses in the outgas measurements, which provide average information about the reactor state. Pulse responses can be discerned at $t = 23.15$ h and at $t = 23.3$ h in the outgas signal, see Figure 14. We do however not use that signal in the feedback algorithm because of the large delay in the responses.

5.4 Simulations of a two compartments system

In order to evaluate the effect of substrate gradients on the pulse programme, simulations of a two compartments system have been performed. The first part represents the feed zone with high substrate concentration and the second one models the bulk zone. The residence time in the feed zone is chosen to 10 s and its size is 10% of the total volume, see [3]. Since, in both experiments, the oxygen probe was located far from the feeding point, the oxygen signal from the larger volume is used for feedback. Figure 15 shows that acetate is produced in the feed zone because of the high glucose concentration. Acetate is transferred to the bulk zone where some acetate is consumed and the concentration remains low (not shown).

In Figure 16 the trajectories of the compartment system and the homogeneous reactor are compared in the $(q_g, q_a^{c,pot})$ -plane. The setpoint y_r in the feeding algorithm makes it possible to keep a distance between q_g and the saturation limit defined by $q_o = q_o^{max}$, see [5]. It is remarkable that the distance from the stationary point to the saturation line is the same in the two simulations. This shows some robustness properties of the control system in presence of acetate and concentration gradients.

The feeding strategy tends to maximize the biomass productivity and avoids acetate formation. It does not mean that the protein production is optimized or that other byproducts are not produced. In large scale bioreactors formate is another byproduct that may be formed, especially under oxygen-limiting conditions, see [2].

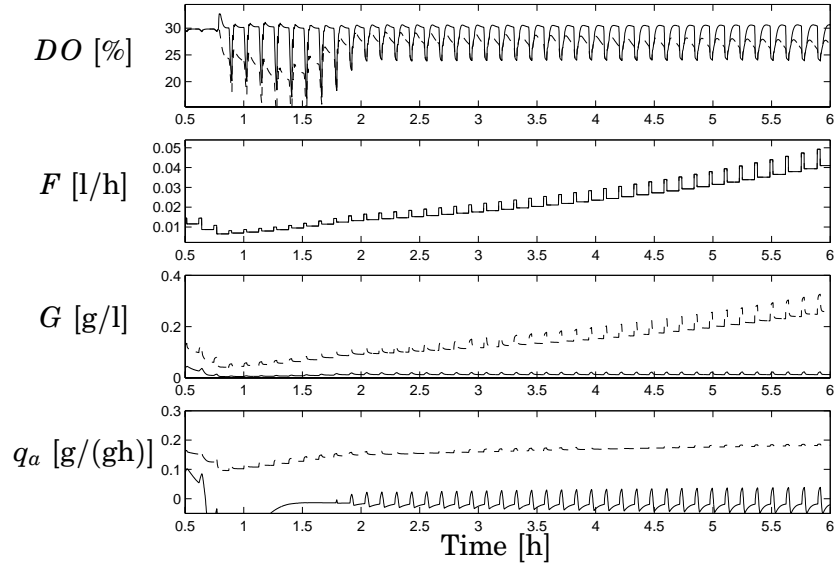

Figure 15 Simulation of a two compartments system. The solid line is the concentration in the bulk zone and the dashed line is the concentration in the feed zone.

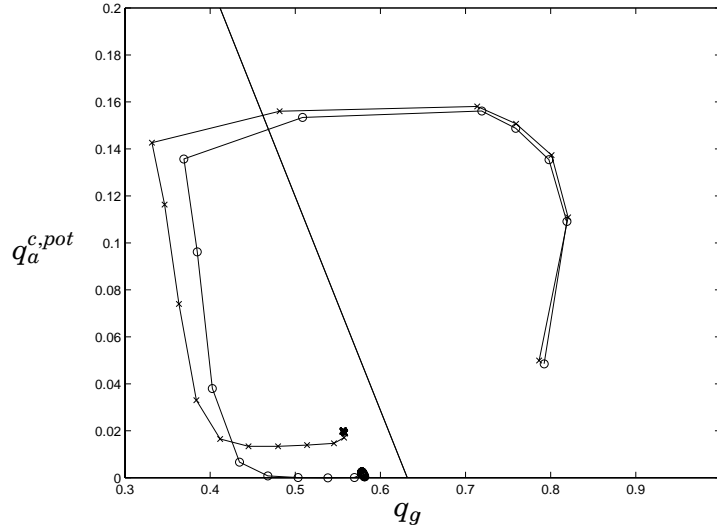

Figure 16 Simulations of the feeding strategy in the homogeneous reactor (circles) and in the two compartments system (crosses). To the right of the straight line the respiratory system of the cells is saturated: $q_o > q_o^{max}$.

It has been reported that even at high DO values, mixed acid fermentation products such as acetate and formate may be formed. Release of DNA due to cell lysis reduces the oxygen transfer to the cell surface and might cause formate formation. This points out another difficulty related to the bioreactor scale. Aerobic conditions are not guaranteed even though the dissolved oxygen concentration is kept at 30 % by feedback control.

It is regrettable that the analysis cannot be confirmed by offline measurements.

6. Conclusion

The probing feeding strategy has been implemented and tested on a production scale bioreactor. Satisfactory results in terms of recombinant protein amounts have been obtained for both experiments. The major improvement compared to the fixed profiles is that it uses the full capacity of the reactor whereas the risk of overfeeding and oxygen limitation is minimized. The operation at a higher oxygen transfer capacity results in a shorter cultivation time. Well-tuned controllers are required for an accurate control of the feed flow and the dissolved oxygen tension. A gain scheduling approach would be suitable to get a better regulation of the dissolved oxygen signal.

The feeding strategy has fully succeeded in the sense that, at the first attempt, good results have been obtained. The introduction of feedback control is also a major progress when seeking for reliability and reproducibility.

7. Acknowledgment

Jan Haglund implemented the control algorithm in the plant process control system. Plant technicians Sarmite Fonzovs, Peter Gustafsson, Peter Andersson, Christian Thell and Per Sandgren are thanked for all help outside normal operations and for willingly working at odd hours. Anders Eriksson reviewed the report and his encouragement is appreciated.

8. References

- [1] K. J. Åström and T. Hägglund. “PID control.” In Levine, Ed., *Control System Fundamentals*, pp. 198–209. CRC Press, 1999.
- [2] F. Bylund, A. Castan, R. Mikkola, A. Veide, and G. Larsson. “Influence of scale-up on the quality of recombinant human growth hormone.” *Biotechnology and Bioengineering*, **69:2**, july 2000.
- [3] F. Bylund, F. Guillard, S.-O. Enfors, C. Trägårdh, and G. Larsson. “Scale down of recombinant protein production: a comparative study of scaling performance.” *Bioprocess engineering*, **20**, pp. 377–389, 1999.
- [4] A. Castan and S.-O. Enfors. “Characteristics of a do-controlled fed-batch culture of escherichia coli.” *Bioprocess Engineering*, **22**, pp. 509–515, 2000.
- [5] M. Åkesson. *Probing Control of Glucose Feeding in Escherichia coli cultivations*. PhD thesis, 1999.
- [6] M. Åkesson and P. Hagander. “A simplified probing controller for glucose feeding in escherichia coli cultivations.” In *IEEE Conference on Decision and Control*, Sydney, Australia, 2000.
- [7] M. Åkesson, P. Hagander, and J. P. Axelsson. “An improved probing controller for substrate feeding in fed-batch cultures of e. coli: simulations and experiments.” In *Computer Applications in Biotechnology*, Quebec, Canada, 2001.
- [8] M. Åkesson, E. N. Karlsson, P. H. J. P. Axelsson, and A. Tocaj. “On-line detection of acetate formation in *Escherichia coli* cultures using dissolved oxygen responses to feed transients.” *Biotechnology and Bioengineering*, **64:5**, september 1999.

A. Cultivation 1

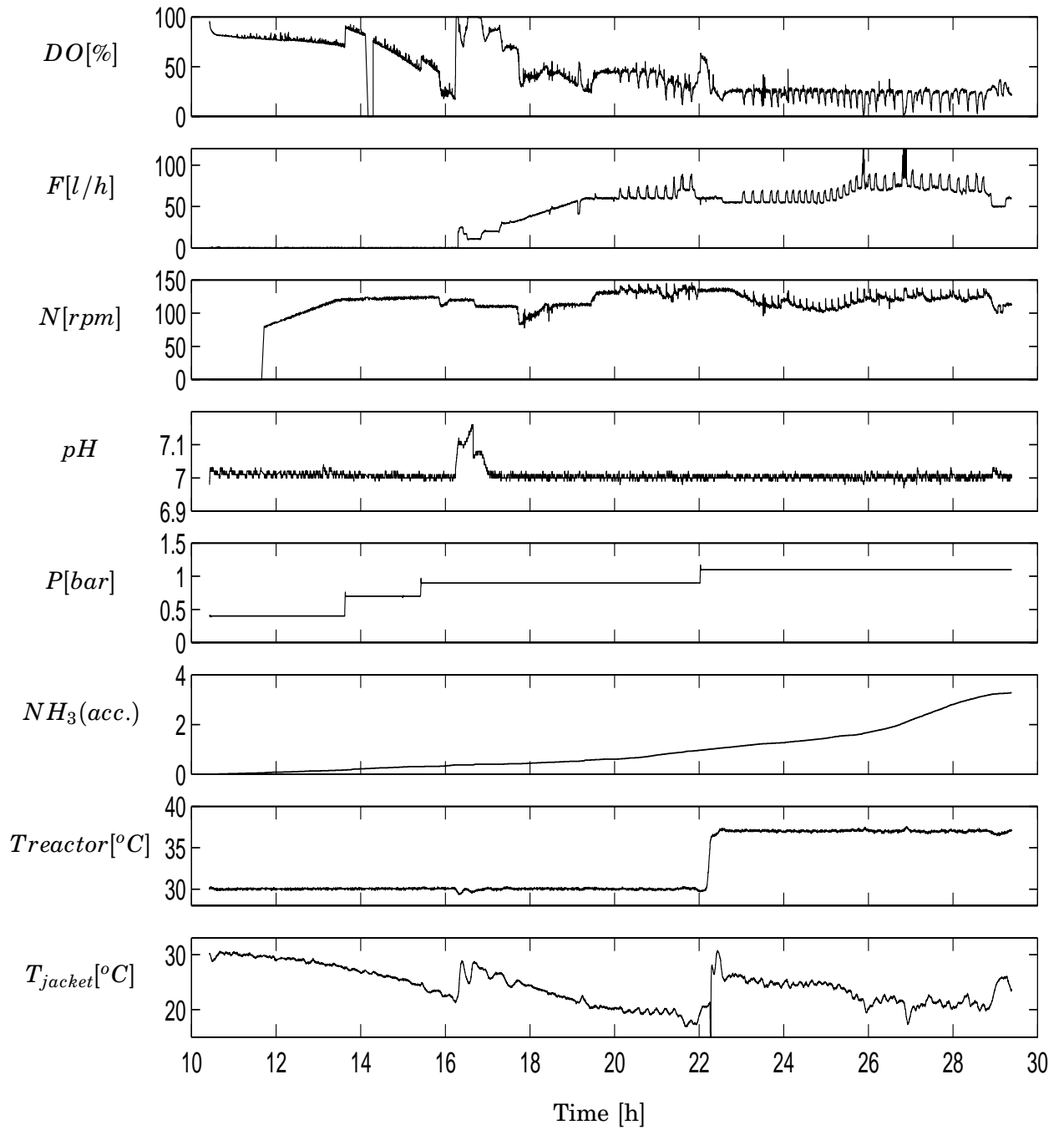

B. Cultivation 2

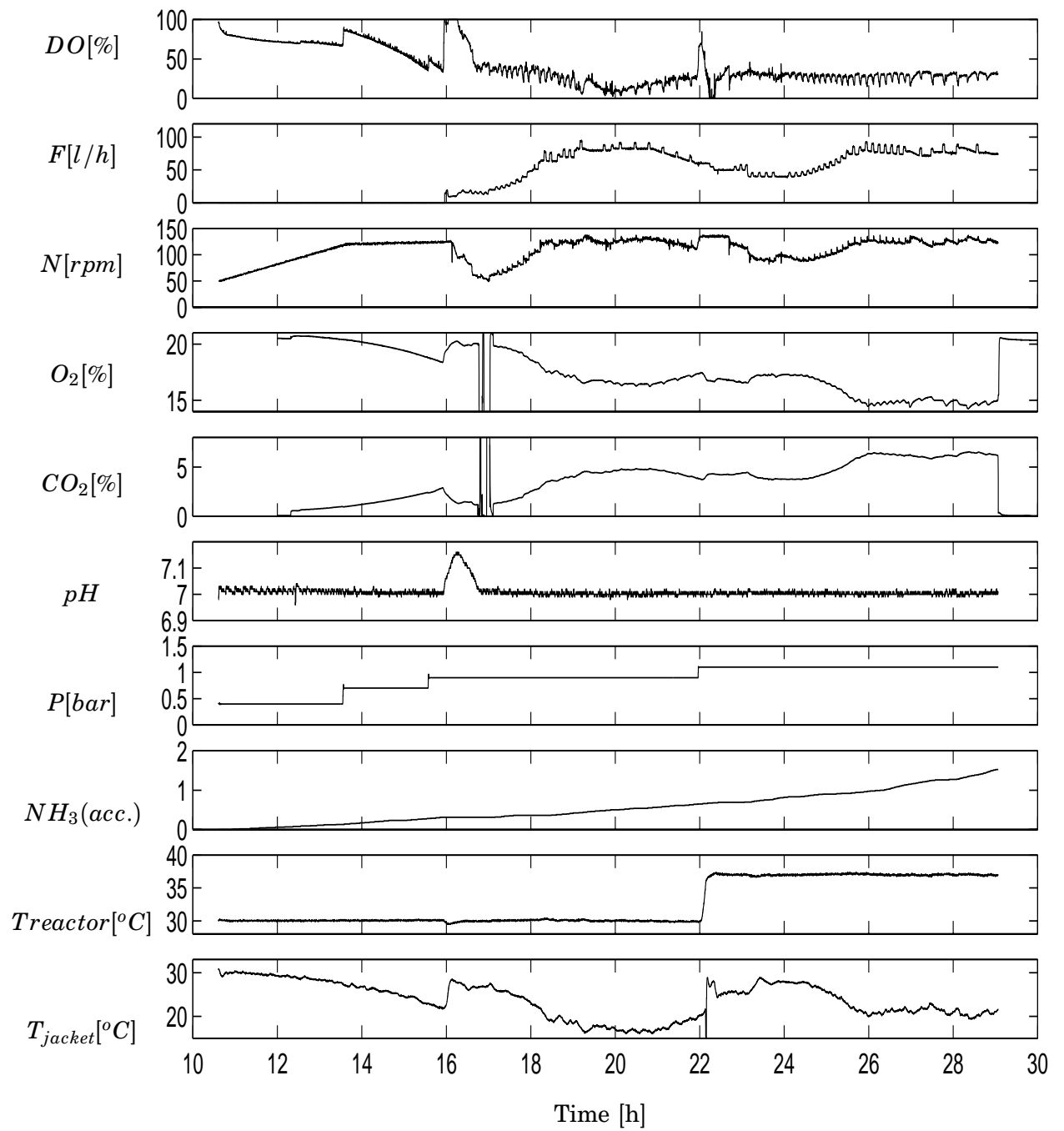

C. Feedback algorithm

1. Freeze the stirrer speed for DO control
2. Make an up pulse in the feed: $F_{\text{pulse}}(t) = \gamma P * F(t-1)$
3. Compute the pulse response $O_{2\text{mean}}$ as an average from the time $O_{2\text{tid1}}$ to $O_{2\text{tid2}}$
4. $O_{2\text{pulse}} = O_{2\text{sp}} - O_{2\text{mean}}$
5. Update the control error $e(t) = O_{2\text{pulse}} - O_{2\text{pulseSP}}$
6. Compute delta $F(t)$:

```
IF O2pulse < O2reac
  THEN delta F(t) = -gammaD * F(t-1)
ELSE
  IF N(t) > Nhigh
    THEN delta F(t) = 0
  ELSE
    I(t) = I(t-1) + e(t)
    delta F(t) = (k * e(t) + ki * I(t)) * F(t-1) / (O2max - O2sp)
  END
END
```
7. Update $F(t) = F(t-1) + \text{delta } F(t)$
8. Set the set-point for the feed control to $F(t)$
9. Activate the DO-control
 - a) Wait a time T_{controlX}
 - b) Decrease $F(t)$ when the stirrer speed is too high:

```
IF N(t) > Nhigh2
  THEN F(t) = F(t-1) - TcontrolX * Fadj / Tcontrol
END
```
 - c) Goto a)
10. Wait until T_{control} has passed

D. Parameters value

Tuning rules for the pulse programme are given in [5]. The values used in the experiments are listed in the table below.

Parameter name	Mats name	Value
Tcontrol	$T_{control}$	6 min
Tpulse	T_{pulse}	3 min
O2max	O^*	100 %
O2pulseSP	y_r	10 %
O2sp	O_{sp}	30 %
O2tid1	–	- 30 s
O2reac	–	3 %
Nhigh	N_{high}	121 rpm
Nhigh2	N_{high2}	128 rpm
GammaP	γ_P	20 %
GammaD	γ_D	20 %
Gamma	γ	10 %
K	K	0.95
Ki	K_i	0

The parameters values have been adjusted manually to get good performance at every moment of the cultivation. The values N_{high} and N_{high2} have been respectively chosen to be $0.9N_{max}$ and $0.95N_{max}$ which $N_{max} = 135 \text{ rpm}$.

For an easier interpretation of the pulse programme behavior, no integral action has been used ($K_i = 0$). The feed adjustments depend only on the oxygen response to the latest feed pulse.

E. Future experiments

The two cultivations performed during winter 2000 constitute the first experiments done with the pulse programme on a industrial scale bioreactor. The aim of these experiments was to evaluate the performance of the probing strategy in large scale cultivations. Satisfactory results have been obtained for both cultivations. The feeding strategy behaved as expected and no major difficulties related to the scale have been encountered.

However, the results cannot be conclusive without off-line measurements. Since the main characteristic of the probing strategy is to avoid acetate formation and no acetate measurement was available, no definitive result can be established. The absence of saturation in the oxygen responses to feed pulses strongly indicates that no overfeeding situation occurred in any cultivation. But, in order to prove the efficiency of the probing strategy, it is essential to see its behavior in situations, such as when acetate is at the limit to be produced. It would also be interesting to measure the concentration of other organic acids than acetate in order to estimate the effects of oxygen limitations on the probing strategy. In both cultivations, the pulse programme has been turned off on several occasions, such as for tuning controllers or during the post-induction phase. It would be preferable to let the probing strategy control the feed rate almost all the time for an easier interpretation of the results.

The good results obtained with the feeding strategy for both cultivations are promising. It seems however valuable to carry out more experiments for a better evaluation of the probing strategy.

