



LUND UNIVERSITY

The S1-calorimeter : a simple isothermal heat conduction calorimeter

Wadsö, Lars

1998

[Link to publication](#)

Citation for published version (APA):

Wadsö, L. (1998). *The S1-calorimeter : a simple isothermal heat conduction calorimeter*. (Report TVBM (Intern 7000-rapport); Vol. 7124). Division of Building Materials, LTH, Lund University.

Total number of authors:

1

General rights

Unless other specific re-use rights are stated the following general rights apply:

Copyright and moral rights for the publications made accessible in the public portal are retained by the authors and/or other copyright owners and it is a condition of accessing publications that users recognise and abide by the legal requirements associated with these rights.

- Users may download and print one copy of any publication from the public portal for the purpose of private study or research.
- You may not further distribute the material or use it for any profit-making activity or commercial gain
- You may freely distribute the URL identifying the publication in the public portal

Read more about Creative commons licenses: <https://creativecommons.org/licenses/>

Take down policy

If you believe that this document breaches copyright please contact us providing details, and we will remove access to the work immediately and investigate your claim.

LUND UNIVERSITY

PO Box 117
221 00 Lund
+46 46-222 00 00



The S1 calorimeter; a simple isothermal heat conduction calorimeter

Lars Wadsö

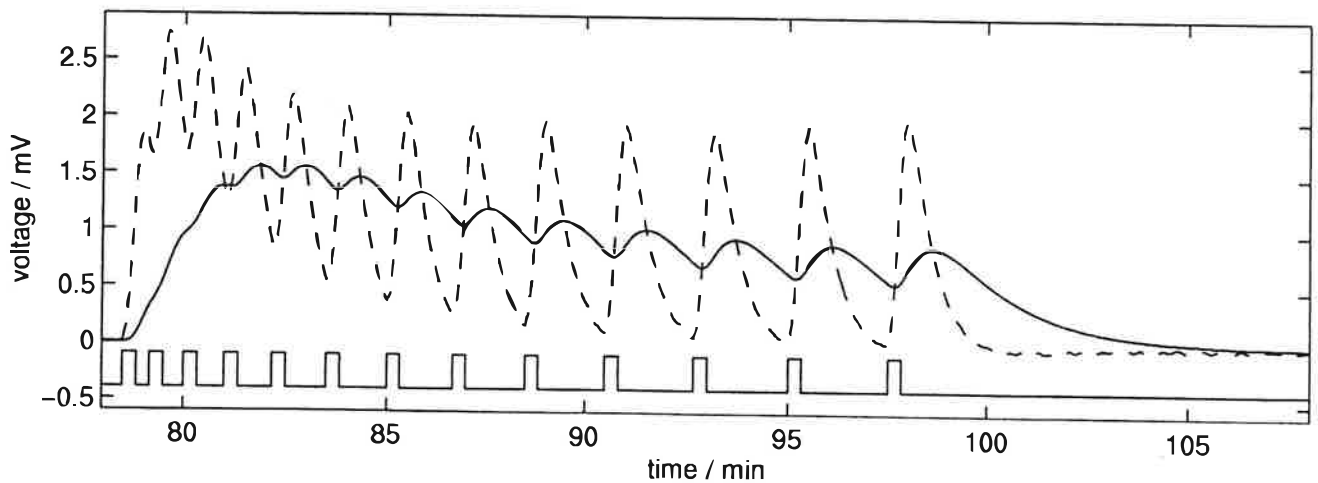

The S1 calorimeter; a simple isothermal heat conduction calorimeter.

Lars Wadsö
Building Materials, Lund University*

1 Introduction

This report presents the design and testing of a simple isothermal heat conduction calorimeter for measurements of thermal powers (heat production rates). The calorimeter has been designed to be inexpensive, but still work by similar principles as a commercial microcalorimeter. Its main uses are:

- In university and industrial laboratories to study processes that release relatively large amounts of heat; i.e. in situations where it is not necessary to use a microcalorimeter. One classical use for this type of calorimeter is to study cement hydration, but many other uses are possible.
- For student experiments in physics, chemistry, biology etc. By choosing processes with high enthalpy changes it is possible to develop student experiments with the S1 calorimeter in all fields of science.

In this report the S1-calorimeter design is described, some theoretical aspects are discussed, and properties of the instrument are evaluated from experiments. Details of two differently manufactured S1-calorimeters are given in Appendices A and B. Wadsö (1998) gives eight examples of experiments done with the instrument type.

*This work was carried out at Division of Thermochemistry, Lund University

2 Nomenclature

| | | |
|---------------|---------------------------------|-----|
| C | heat capacity | J/K |
| E | Seebeck coefficient | V/K |
| k | thermal conductivity | W/K |
| P | thermal power | W |
| n | number of thermocouples per TCP | 1 |
| q | heat flow rate | W |
| T | temperature | K |
| U | voltage | V |
| ε | calibration coefficient | W/V |
| σ | sensitivity | V/W |
| τ | time constant | s |

indices:

| | |
|---|-----------------|
| 0 | ambient |
| 1 | heat sink |
| 2 | measurement cup |
| 3 | reference cup |

The letters with a bar (\bar{k} and \bar{E}) denote properties of the thermocouple plates.

3 The calorimeter design

The main features of the S1-calorimeter are:

- The heat production rate is measured by semiconductor thermocouple plates (Peltier plates).
- It is a twin calorimeter as the difference between the output from the measurement cell and a reference cell is registered.
- The heat sink is a large (6-9 kg) piece of aluminum with a high heat capacity.
- Temperature stability is achieved by a 50 mm insulation and by placing the calorimeter in a temperature controlled environment.

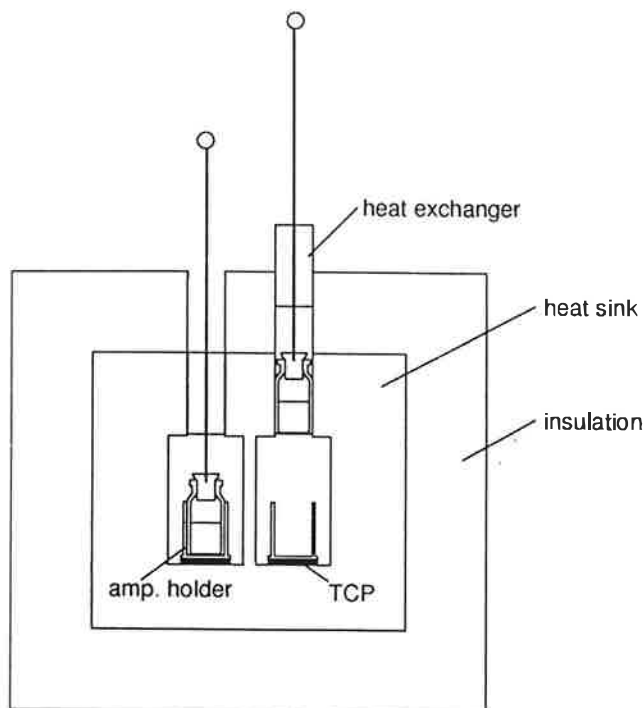

Figure 1: The general design of the S1 calorimeter. The left ampoule is down in the calorimeter with the heat exchanger in the heat exchange zone, while the right ampoule is in the thermostating position.

- Experiments are made in 10 ml glass vials (ampoules) that are sealed by rubber stoppers.
- It is easy to arrange for perfusion, titration, mixing etc. through the rubber stoppers.

Figure 1 shows the principle of the S1-calorimeters. An aluminum block contains two entrance holes (heat exchangers), two cavities where the calorimetric units are housed, and a bottom part which serves as a primary heat sink. The entrance holes should have a diameter which is 0.15–0.20 mm larger than the diameter of the ampoule; in the present case the holes have a diameter of 22.70 mm to fit the ampoules that have a mean diameter of 22.55 mm. Note that if the ampoules are uniform they will all fit into one hole; if not, some of the larger ampoules in a lot will have to be discarded. Two versions of the calorimeter have been made that are thermally similar, but are manufactured differently. Details of these two versions are given in Appendices A and B.

4 The ampoules

The ampoules are ordinary 10 ml glass vials (chromatography vial #6655, Alltech, USA). Their diameter was found to be quite uniform both within each vial and for different vials.

Two types of rubber stoppers were used: an ordinary red one and a more elastic gray one. The latter is more porous, but also more vapor tight. The vapor tightness of both types of stoppers were tested by sealing vials with a small amount of water with stoppers and then weighing them at regular intervals. The mass losses were 0.15 and 0.08 mg/day for the red and the gray stoppers, respectively (25°C and a water activity difference in the order of 0.6). For the grey stoppers this evaporation will give a thermal power in the order of 2 μ W. However, the colors of the stoppers changed when they were in contact with water vapor so there may also be some heat produced from the combined evaporation in the ampoule and absorption in the stoppers. This effect may be assessed in a separate experiment.

The rubber stoppers are very flexible and one can easily make different arrangements for perfusion, injection, stirring etc. This is best made by putting the stoppers in a holder (a vial will do), then drilling slowly through them with a 1 mm drill, and finally pushing a 1 mm stainless steel tube through the hole. If the tube is made long enough (e.g. 20 cm) the diffusion of vapor through the tube to the outside will be low. Figure 2 gives some examples of different vessel arrangements.

|| For reasons of safety, always mark the end of thin tubes, i.e. with a small flag. ||
|| It is otherwise easy to hurt your eyes on the ends of the tubes. ||

To protect the ampoule when it is in the measuring position a brass heat exchanger with a diameter of 22.55 mm is used (cf. Fig. 1). This has holes drilled with a 1.1 mm drill that will accept the 1 mm stainless steel tubes used. The heat exchanger is fixed to its position by 5 mm lengths of a small silicon tubing on the steel tubes below the heat exchangers (not shown in Fig. 1).

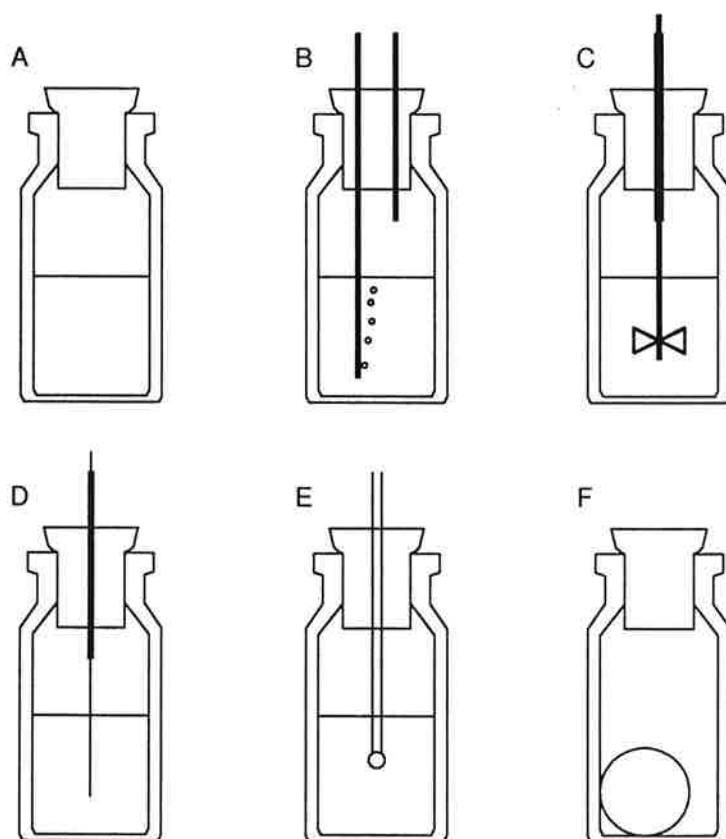

Figure 2: Six ways of using the vials and the stoppers. **A.** A closed ampoule with a liquid. **B.** Perfusion of gas through a liquid. **C.** Mixing of a liquid. **D.** Injection (titration) of a liquid or a gas into a liquid. **E.** A sensor in the ampoule (e.g. a thermistor for a scanning experiment, or a pH-sensor). **F.** A closed ampoule with a solid sample.

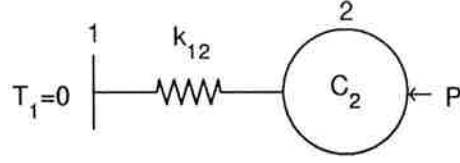

Figure 3: The simple thermal system used to derive the Tian equation.

5 Theoretical models of the S1 calorimeter

5.1 The model for the Tian equation

The simplest thermal model of a calorimeter of the S1 type is shown in Fig. 3. With this model the produced thermal power P (W) may be calculated from the measured voltage U (V). Sample, ampoule and ampoule holder have a heat capacity C_2 that is connected to the constant temperature heat sink through the thermal conductivity k_{12} of the thermocouple plate (TCP). To simplify the mathematical manipulations we set the temperature of the heat sink to 0 (i.e. we subtract the heat sink temperature from all temperatures).

For simplicity the indices for the following parameters are left out in the following: $E = E_{12}$; $U = U_{12}$; $P = P_2$.

The following equations will apply for the case described above and given in Fig. 3:

$$q_{12} = k_{12}T_2 \quad (1)$$

$$C_2 \frac{dT_2}{dt} = P - q_{12} \quad (2)$$

$$U = ET_2 \quad (3)$$

If T_2 is replaced by U/E (Eq. 3) and q_{12} from Eq. 1 put into Eq. 2 the result will be the Tian equation:

$$P = \varepsilon \left(U + \tau \frac{dU}{dt} \right) \quad (4)$$

Here, the calibration coefficient ε (W/V) is:

$$\varepsilon = \frac{k_{12}}{E} \quad (5)$$

The time constant τ (s) is:

$$\tau = \frac{C_2}{k_{12}} \quad (6)$$

The time constant τ is the time it takes for the signal to drop from one voltage value to 37% (e^{-1}) of this value when there is no heat produced; or the time it takes for the signal to go from zero to 63% ($1-e^{-1}$) of the maximal output value when a constant thermal power is introduced into the measurement cell. More than one time constants may also be used if the gradients within the ampoule are large, but this has not been done here.

When we make an electrical calibration we have a calibration ampoule that can produce a thermal power. If we start with the system in equilibrium and at time zero ($t=0$) apply a constant thermal power P we get an output of the following general form:

$$U(t) = \frac{P}{\varepsilon} (1 - \exp(-\frac{t}{\tau})) \quad (7)$$

After some time (a practical time may be 10τ) we reach equilibrium with constant voltage output $U=P/\varepsilon$. If we then stop applying the thermal power (at time zero, $t=0$) we will get a declining output voltage:

$$U(t) = \frac{P}{\varepsilon} \exp(-\frac{t}{\tau}) \quad (8)$$

The Tian equation (Eq. 4) has been used to calculate the true thermal power from the measured signal. Two examples of this are given in Figs. 9 and 10. As is seen in the figures, this calculation does not restore the original curves (pulses of thermal power) perfectly. This is because the system cannot be described with only one time constant, mainly because there are internal temperature gradients within the ampoule. For short pulses (Fig. 9) the corrected curve never reaches a steady state, but it substantially sharpens the peaks. For long pulses (Fig. 10) the original square shape is restored quite well.

In making the Tian correction one may chose a time constant that is as near as possible to the true value of the main time constant. Then one will most likely get a small overshoot and an initial dip in the curves as seen in Fig. 10. If one does not like that one may always chose a lower time constant and make a partial correction.

An unideal calorimeter will not have k and E that are the same as those of the TCP itself (\bar{k} and \bar{E}) because there are other heat flow resistances .

Figure 4 gives a model for possible heat flow resistances between the sink and the measurement position. In a real system k_x may be caused by the heat flow resistance of an adhesive used to fasten the TCP:s, and k_y may come from the heat diffusion in the air between the ampoule holder and the heat sink (or the tube that connects the ampoule with the heat exchanger). This may be further investigated by writing the equations for the effective parameters k and E :

$$k = k_y + \frac{k_x \bar{k}}{k_x + \bar{k}} \quad (9)$$

$$E = \frac{\bar{E} k_x}{k_x + \bar{k}} \quad (10)$$

The resulting calibration coefficient is found as the ratio of k and E :

$$\varepsilon = \frac{1}{\bar{E}} \left(k_y \left(1 + \frac{\bar{k}}{k_x} \right) + \bar{k} \right) \quad (11)$$

The resulting time constant is found from:

$$\tau = \frac{C_2}{k_y + \frac{k_x \bar{k}}{k_x + \bar{k}}} \quad (12)$$

It is difficult to calculate k , E etc. from such models as k_x and k_y are usually unknown, but it is interesting to note that if $k_y=0$, then the calibration coefficient ε is not influenced by k_x (the time constant will still be influenced by k_x).

Table 1 presents some calculations of ε and τ for different cases. The cases which are closest to the situation in the S1 calorimeters are cases A or B for k_x and case B for k_y . It is seen in the results that ε is hardly affected at all. The only significant effect seen is the increase in τ when k_x is decreased. This is also seen in the results from the calibrations that give significantly higher values of τ than predicted by Eq. 6 using \bar{k} and \bar{E} . This increased tau is only a disadvantage for rapid measurements and for calorimeters where k_x is not the same for the measurement and the reference side (this may be checked by calculating time constants from calibrations on both sides with the same calibration ampoule).

If the time derivative of the decay curve can be calculated this can be used to evaluate the time constant τ at every point on a measured decay

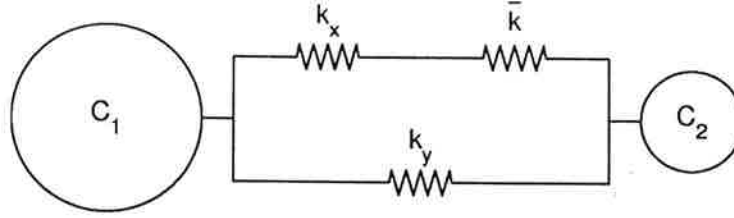

Figure 4: The possible heat flow paths between the heat sink and the measurement position with ampoule, ampoule holder etc.

Table 1: Calculation of k_x and k_y for different possible cases and their impact on the calibration coefficient ε and the time constant τ . For all calculations of the time constant a heat capacity of 35 J/K has been used.

| calculations of k_x (at each TCP surfaces) | | |
|---|---|--|
| A | 0.1 mm adhesive with $\lambda = 1$ W/m/K | $k_x=4.5$ W/K |
| B | 0.01 mm air gaps | $k_x=1$ W/K |
| C | 1 mm adhesive with $\lambda = 0.5$ W/m/K | $k_x=0.2$ W/K |
| calculations of k_y (conductance in parallell with \bar{k} and k_x) | | |
| A | 1 cm of 0.1 mm^2 metal with $\lambda = 100$ W/m/K | $k_y=0.001$ W/K |
| B | air gap* between ampoule holder and heat sink | $k_y=0.0004$ W/K |
| C | 10 cm of 1 mm stainless steel tube | $k_y=0.0001$ W/K |
| calculation of calibration coefficients ε and time constants τ | | |
| $k_x = \infty$ W/K; $k_y = 0$ W/K (ideal case) | | $\varepsilon=13.32$ W/V; $\tau=87.3$ s |
| $k_x = \infty$ W/K; $k_y = 0.001$ W/K | | $\varepsilon=13.36$ W/V; $\tau=87.1$ s |
| $k_x = \infty$ W/K; $k_y = 0.0004$ W/K | | $\varepsilon=13.34$ W/V; $\tau=87.2$ s |
| $k_x = 4.5$ W/K; $k_y = 0$ W/K | | $\varepsilon=13.32$ W/V; $\tau=95.1$ s |
| $k_x = 1$ W/K; $k_y = 0$ W/K | | $\varepsilon=13.32$ W/V; $\tau=122$ s |
| $k_x = 0.2$ W/K; $k_y = 0$ W/K | | $\varepsilon=13.32$ W/V; $\tau=262$ s |

* height: 30 mm, thickness: 6 mm, radius: 31 mm, $\lambda=0.024$ W/m/K, no convection

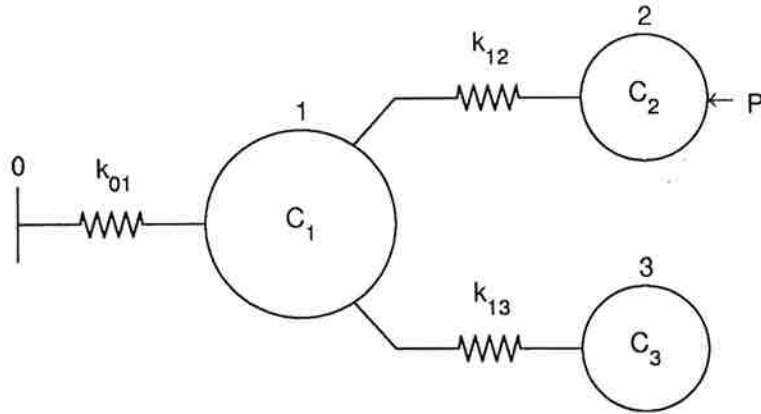

Figure 5: A more complete thermal description of an unthermostated calorimeter.

curve. The equation used is found by dividing Eq. 8 with its derivative:

$$\bar{\tau}(t) = \frac{-U}{\frac{dU}{dt}} \quad (13)$$

Here the time constant is written with a tilde because it may change as a function of time if the system cannot be exactly described with only one time constant. This equation has not been used here.

5.2 Temperature changes of the heat sink

The temperature of the heat sink may be influenced by the heat flows from the sample cups and from the ambient room through the insulation (cf. Fig. 5). The following equations apply when a thermal power P is produced in the measurement cup and only slow temperature changes are taken into account (the measurement and reference cups are not taken into account here as C_2 and C_3 are much smaller than C_1):

$$C_1 \frac{dT_1}{dt} = k_{01}(T_0 - T_1) + P \quad (14)$$

Usually only one (if any) of the right hand side terms have to be taken into account:

- If the ambient temperature (T_0) is close to the temperature of the calorimeter (T_1) *and* the heat production rate (P) is low, then T_1 will not change significantly.
- If the ambient temperature (T_0) is close to the temperature of the calorimeter (T_1) *but* the heat production in the calorimeter (P) is high, then T_1 will change according to:

$$C_1 \frac{dT_1}{dt} = P \quad (15)$$

- If the heat production in the calorimeter is small, *but* the ambient temperature (T_0) differs significantly from the temperature of the calorimeter (T_1), then T_1 will change according to:

$$C_1 \frac{dT_1}{dt} = k_{01}(T_1 - T_0) \quad (16)$$

If the temperature of the heat sink changes with time and the heat capacity of the measurement cup (C_2) differs from that of the reference cup (C_3) one may have to add a correction for this (only valid for slow changes in U):

$$P = \varepsilon \left(U + \frac{dT_1}{dt} (C_2 - C_3) \right) \quad (17)$$

This equation is difficult to use in practice as C_2 and C_3 are not well known. However, by assuming a certain difference, e.g. $C_2 - C_3 = 0.3C_2$, one may get an idea of how large the error is *if* one does not take this correction into account.

6 Predicted performance of the S1 calorimeter

The S1 calorimeters are simple constructions whose theoretical primary properties may be found by quite simple calculations using just a few input data:

| | |
|--|----------------------|
| heat conductivity of thermocouple plate CP1.4-71-045L | $\bar{k}=0.401$ W/K |
| Seebeck coefficient of thermocouple plate | $\bar{E}=0.0301$ V/K |
| heat capacity of the 6.6 kg aluminium block | $C_1=5940$ J/K |
| heat conductivity of calorimeter insulation ¹ | $k_{01}=0.158$ W/K |

The data for the thermocouple plates (at 25°C) were calculated by the following equations (enter T in kelvins, Melcor 1995):

$$\bar{k} = 2n\gamma(a_1 + a_2T + a_3T^2) \quad (18a)$$

$$a_1 = 6.26050$$

$$a_2 = -0.02777$$

$$a_3 = 41.31 \cdot 10^{-6}$$

$$\bar{E} = 2n(b_1 + b_2T + b_3T^2) \quad (19a)$$

$$b_1 = 22.2240 \cdot 10^{-6}$$

$$b_2 = 0.9306 \cdot 10^{-6}$$

$$b_3 = -0.9905 \cdot 10^{-9}$$

Here, γ (m) is a geometry factor that is calculated as the area of a TCP-element divided by its length (height). For the Melcor TCP CP1.4-71-045L used in the S1-calorimeters γ equals 0.00171 m. Figure 6 gives an overview of how the properties of the TCP change with temperature. Note that both calibration coefficient and time constant changes markedly with temperature.

The following data was used to calculate the heat capacity of the ampoule etc. (C_2) for the three cases studied in the next section:

| | material | mass / g | spec. heat capacity / J/g/K | heat capacity / J/K |
|----------------|----------|----------|-----------------------------|---------------------|
| ampoule holder | aluminum | 19.3 | 0.95 | 20.2 |
| ampoule | glass | 10.4 | 0.84 | 8.7 |
| stopper | stopper | 2.6 | 1.7 | 4.4 |
| copper powder | copper | 3.82 | 0.39 | 1.5 |
| sand | quartz | 5.0 | 0.75 | 3.8 |

¹An exposed area of approx. 0.22 m (mean of inner and outer area) with a 50 mm polystyrene insulation with $\lambda = 0.036$ W/K/m.

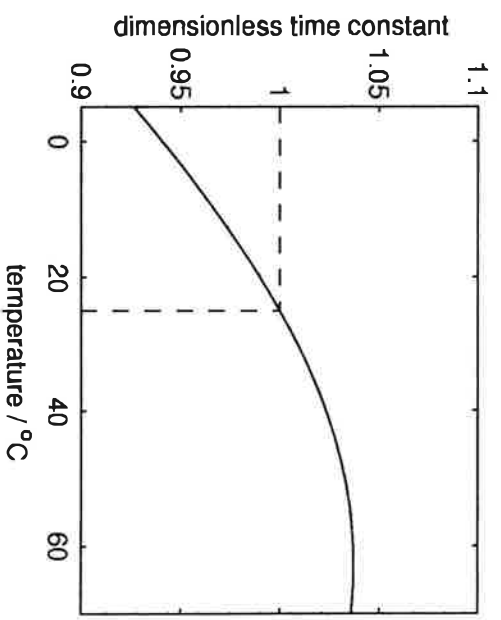
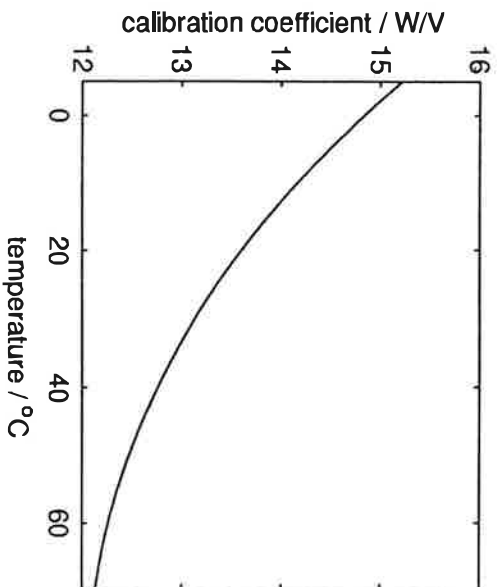
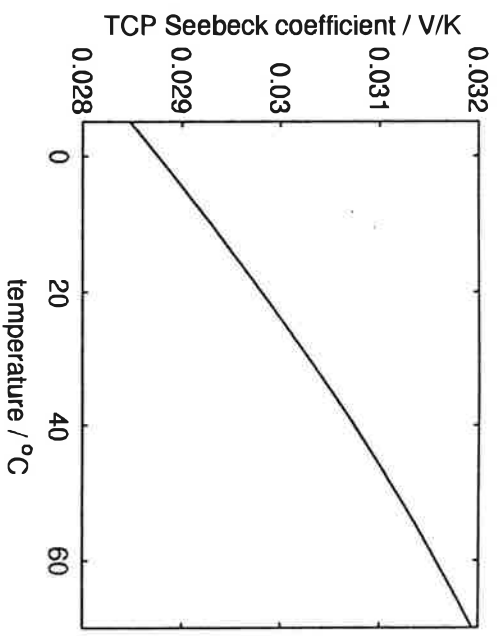
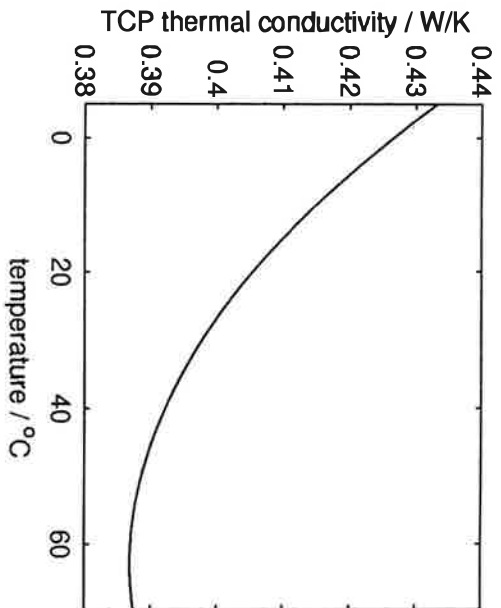

Figure 6: This figure shows how the properties of the TCP depend on T . Note that the time constant have been made dimensionless by dividing with the time constant at 25°C.

This gives the following total heat capacities (C_2):

| | |
|-----------------------------|----------|
| empty ampoule: | 33.3 J/K |
| ampoule with 3.82 g copper: | 34.8 J/K |
| ampoule with 5 g sand: | 37.1 J/K |

Note that the ampoules with 3.82 g copper or 5 g sand are only charged to approx. 20%. If an ampoule is charged with 10 g water it will have a heat capacity of approx. 75 J/K, i.e. a time constant almost twice the one for the ampoule with 5 g sand.

From the data given in the tables above the ideal calorimetric properties may be calculated for 25°C. The calibration coefficient is:

$$\varepsilon = \frac{\bar{k}}{E} = 13.36 \text{ W/V} \quad (20)$$

The time constant of the calorimeter:

$$\tau_{12} = \frac{C_2}{k_{12}} = \begin{cases} 83 \text{ s} & \text{empty ampoule} \\ 87 \text{ s} & \text{ampoule with 3.82 g copper} \\ 92 \text{ s} & \text{ampoule with 5 g sand} \end{cases} \quad (21)$$

The time constant of the calorimetric block:

$$\tau_{01} = \frac{C_2}{k_{02}} = 10 \text{ h} \quad (22)$$

7 The actual performance of the S1-2 calorimeter

7.1 Introduction

The following is based on the performance of the S1-2 calorimeter described in Appendix B. During all measurements presented here a TC-08 thermocouple logger (Pico Technology Ltd., UK) and a PC with Windows 3.1 was used to collect the data. The logger has a 16 bit plus sign mV-range between approx. -60 to 60 mV with a least significant bit of approx. 1 μ V. The TC-08 logger is inexpensive and easy to use, but the noise level etc. could probably be significantly improved with a better logger. One can also see (e.g. in

Fig. 7) that the logger seems to like 0 mV better than other voltages). The measurements were made in the temperature range 20–25°C.

The calorimeter was calibrated electrically. Different currents were passed through an electrical resistance of 2000 Ω that was glued to the bottom of a glass ampoule. The thermal power produced is calculated by the following equation (the resistance of the leads (approx. 1 Ω) could be corrected for):

$$P = \frac{U^2}{R} \quad (23)$$

It is also possible to measure the current I and calculate the thermal power as:

$$P = RI^2 \quad (24)$$

This has the advantage that one does not have to take the lead resistances into account.

7.2 The calibration coefficient

The calibration coefficient may be calculated in two ways (in both cases the baseline should be subtracted first). Either as the ratio of the thermal power input P and a measured steady-state voltage U :

$$\varepsilon = \frac{P}{U} \quad (25)$$

or as the ratio of heat input and the integral of the voltage output:

$$\varepsilon = \frac{Q}{\int U dt} \quad (26)$$

Both these methods, which have been used in the following, should normally give the same value of the calibration coefficient. The sensitivity is calculated as the inverse of the calibration coefficient.

Figures 7, 8, 9 and 10 show four different calibration runs. The measurements shown in Figs. 7 and 8 were made with low thermal powers to find the heat resolution of the calorimeter. Figure 9 shows pulses of higher thermal power to test the time resolution of the instrument and Fig. 10 shows calibrations with high thermal powers. Table 2 gives the results from these calibrations. As one may expect the calibrations with higher heat input gives

Table 2: Results from calibrations. The uncertainties given are calculated by assuming errors of $1 \mu\text{V}$ (1 least significant bit) for the logged voltage and 1 s for the time keeping for the integral measurements. For the data where no uncertainties are given the errors of the above mentioned types are very low; instead the scatter in the data is mainly caused by uncertainty in the applied thermal power of the calibration.

| Fig. | method | P / mW | t / s | calc. ϵ / W/V | comments |
|------|--------|--------|-------|------------------------|---------------------------|
| 7 | int | 0.459 | 2150 | 14.4 ± 0.5 | last s-s peak |
| 7 | s-s | 0.459 | - | 14.6 ± 0.5 | first s-s peak |
| 7 | s-s | 0.459 | - | 14.7 ± 0.5 | last s-s peak |
| 8 | int | 0.459 | 4140 | 14.5 ± 0.5 | main s-s peak |
| 8 | int | 0.459 | 180 | 13.8 ± 0.5 | 3rd small peak from end |
| 8 | int | 0.459 | 180 | 14.0 ± 0.5 | last small peak |
| 8 | s-s | 0.459 | - | 14.5 ± 0.5 | main s-s peak |
| 9 | int | 77.9 | 25 | 15.4 ± 0.5 | first peak |
| 9 | int | 77.9 | 260 | 14.9 ± 0.5 | all middle peaks |
| 9 | int | 77.9 | 20 | 14.8 ± 0.5 | last peak |
| 10 | s-s | 481.2 | - | 14.82 | first peak |
| 10 | s-s | 274.8 | - | 14.81 | second peak |
| 10 | s-s | 149.1 | - | 14.77 | first part of third peak |
| 10 | s-s | 673.7 | - | 14.78 | second part of third peak |
| 10 | int | 481.2 | 1310 | 14.78 | first peak |
| 10 | int | 274.8 | 1815 | 14.79 | second peak |
| 10 | int | * | * | 14.79 | both parts of third peak |

* 2631 s of 0.1491 W plus 2380 s of 0.6737 W

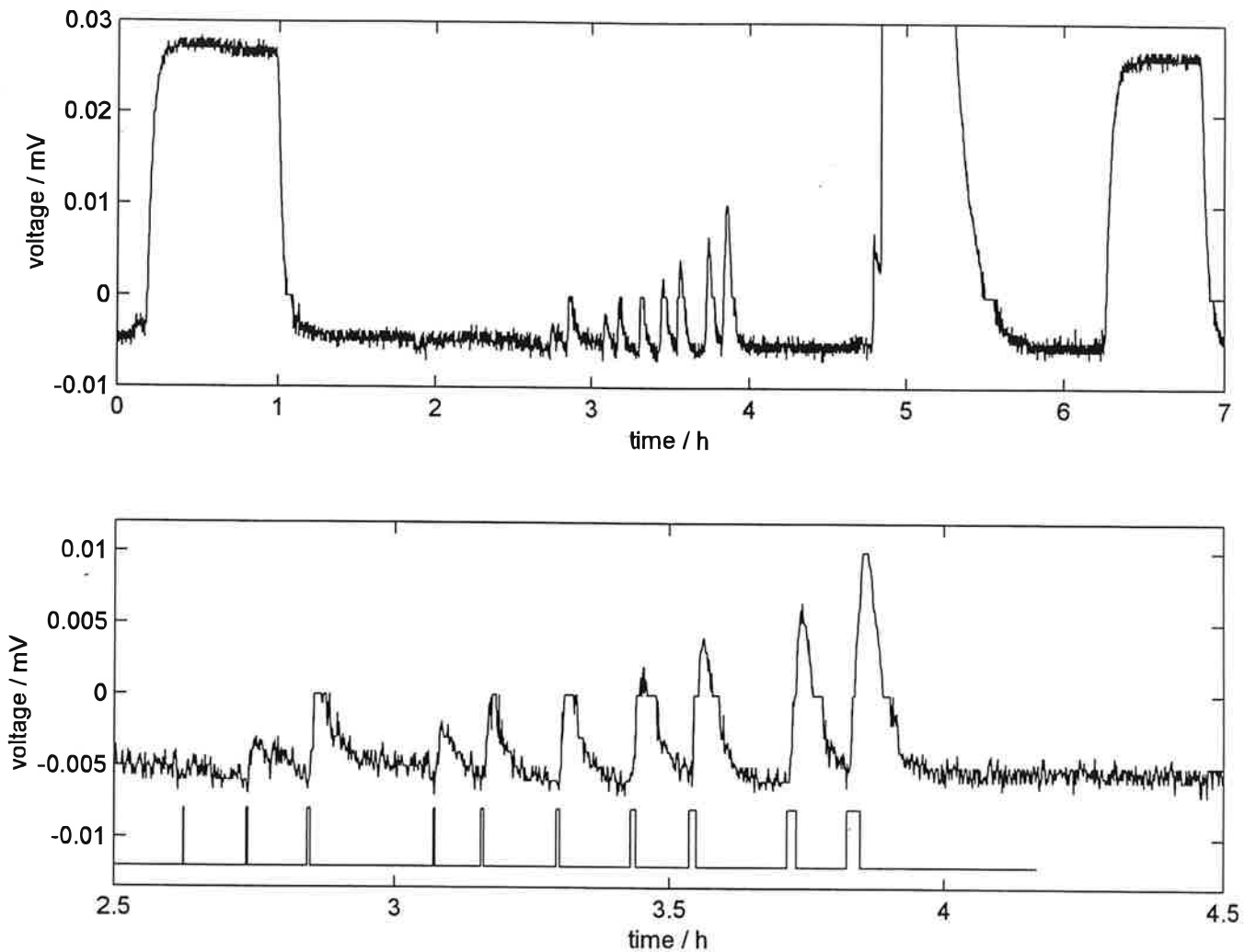

Figure 7: The result of an electrical calibration of the S1-2 calorimeter with pulses of low thermal power (the maximum voltage 0.028 mV corresponds to 0.37 mW). The ampoule was empty except for the electrical resistance. In the top figure the whole experiment is seen. In the bottom diagram the series of short pulses is expanded. The thermal power pulses are indicated in the bottom diagram. From the left to the right the pulses have durations increasing from 5 to 90 s. The third–fifth pulses have heats of approx.10 mJ.

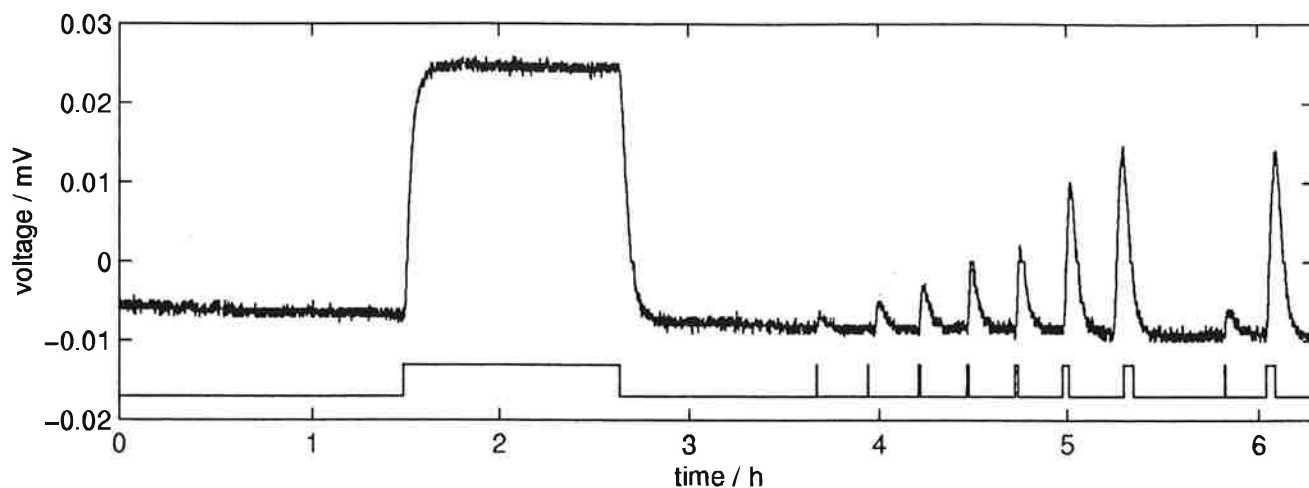

Figure 8: The result of an electrical calibration of the S1-2 calorimeter with pulses of the same low thermal power as in the previous figure. The glass ampoule was filled with 3.82 g copper powder. The pulses are indicated in the bottom of the diagram. From the left to the right the pulses have durations of 4140, 10, 20, 30, 40, 60, 120, 10 and 180 s. The

values with less scatter. This is clearly shown in Fig. 11 where the calculated calibration coefficients are plotted against thermal power or heat.

From the above I conclude that the calibration coefficient is 14.78 W/V. This gives a sensitivity of 0.0677 V/W. The theoretically calculated calibration coefficient is 13.36 W/V (sensitivity 0.0748 V/W). The difference of approx. 10% seen between the calculated and the measured coefficients is probably not caused by other thermal resistances than that of the TCP:s. It could simply be as result of errors/uncertainties in the given values of \bar{k} and \bar{E} .

7.3 Calorimetric time constant

The experiments shown in Figs. 7, 8 and 10 were used to calculate the time constant by noting the time it took for the signal to decrease from 80% of its top value to 37% of this value, or by making a curve fit to a major part of the decay curve. The result is given in Table 3 and Fig. 12 shows that the model of Eq. 8 is very good (i.e. in practice only one time constant is needed). Note also that it is best to skip the start and the end of the decay

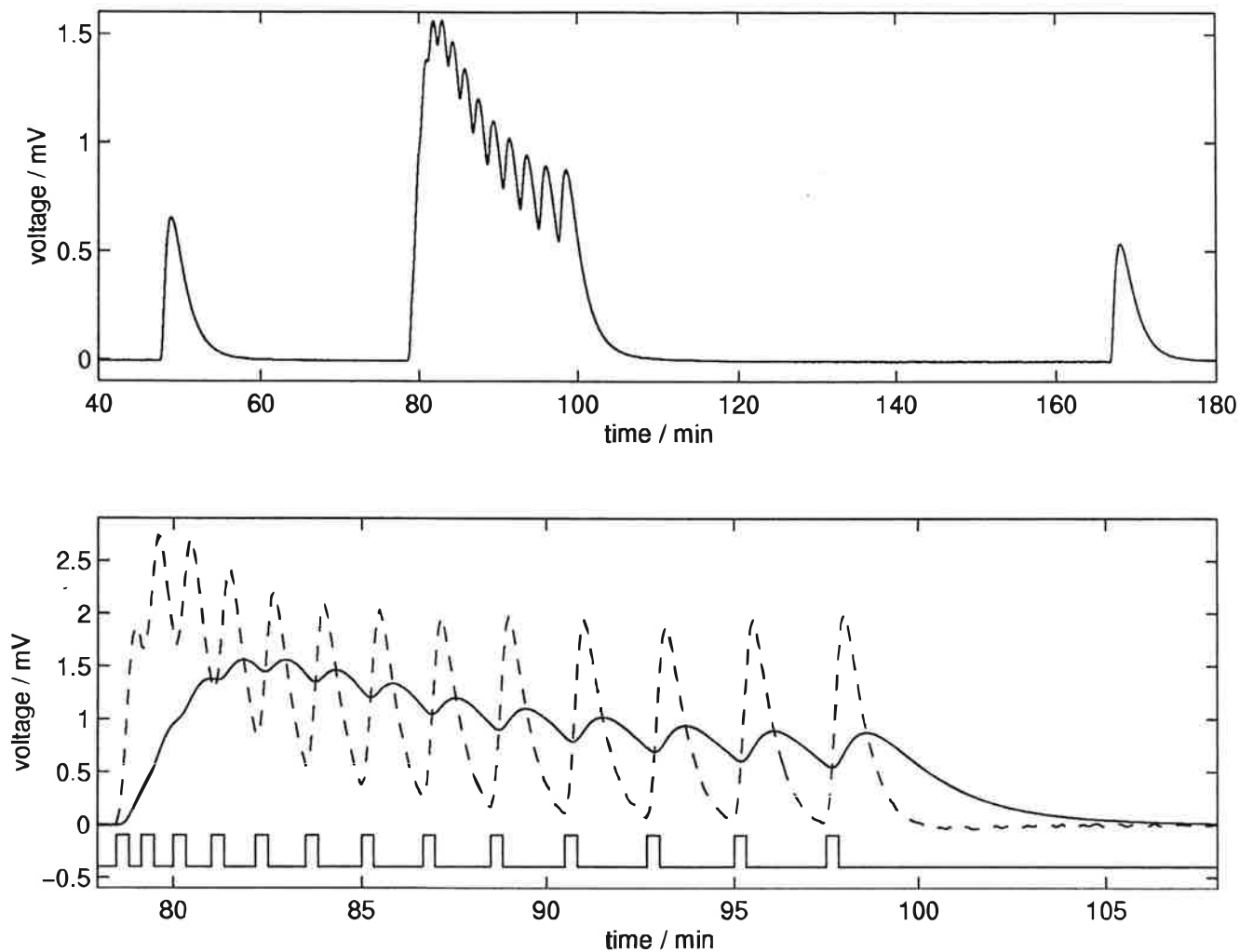

Figure 9: The result of an electrical calibration of the S1-2 calorimeter with pulses of high thermal power (77.9 mW). The first and last pulse have durations of 25 and 20 s, respectively. Between these are seen a series of 20 s pulses made with increasing times from 20 to 130 s between the pulses (expanded in the bottom figure together with a dashed Tian corrected curve). The glass ampoule was filled with 3.82 g copper powder. In the bottom of diagram the pulses are indicated. The measured curve is solid and the Tian corrected curve is dashed.

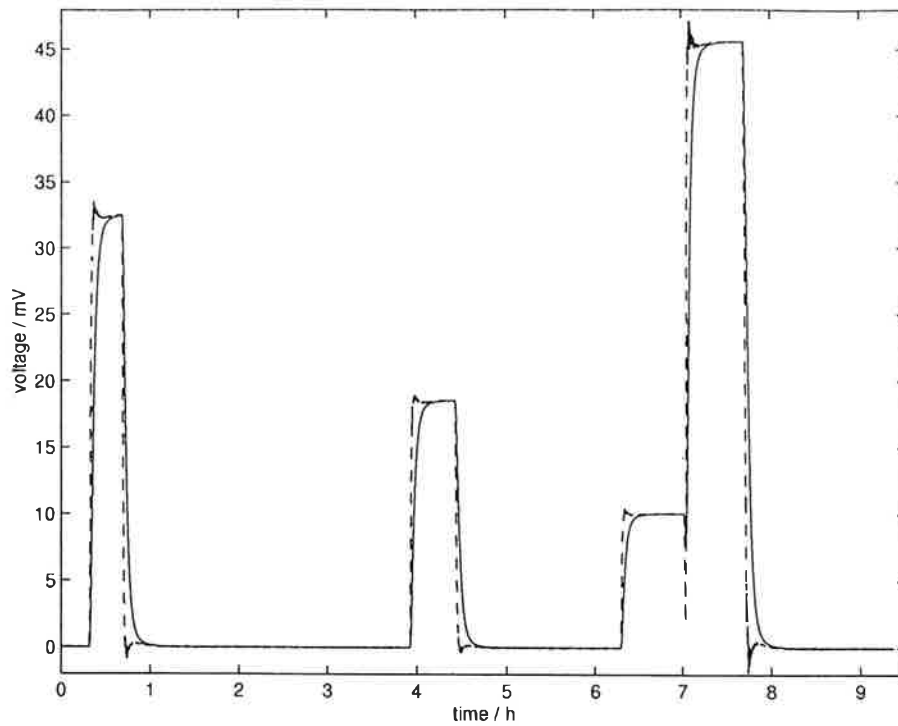

Figure 10: The result of electrical calibrations of the S1-2 calorimeter with high thermal powers (481, 275, 149 and 674 mW for the four plateaus). The glass ampoule was filled with 5 g sand. The measured curve is solid and the Tian corrected curve is dashed.

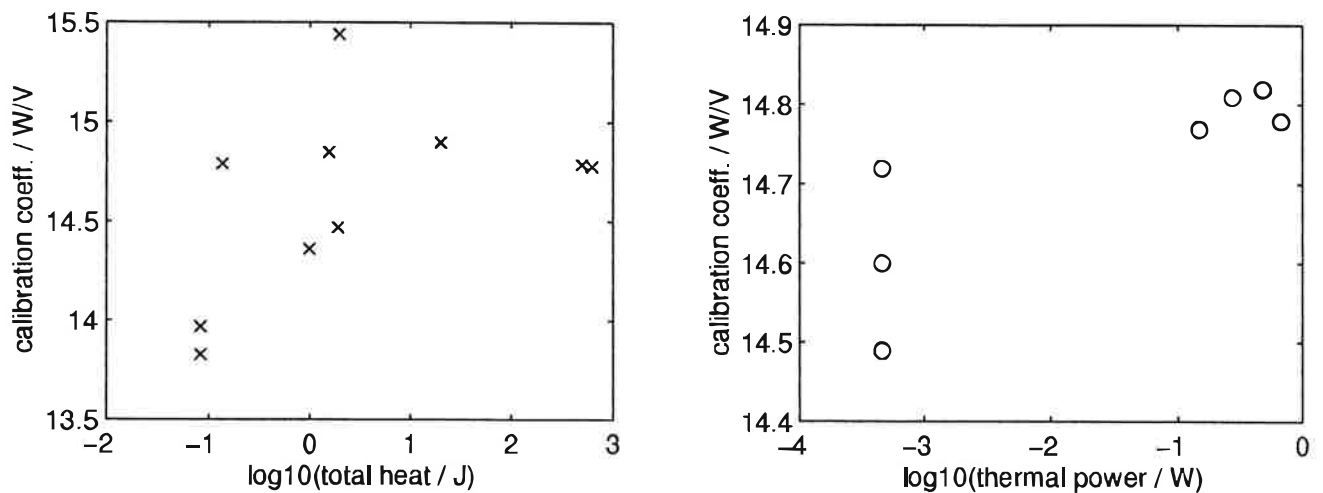

Figure 11: A graphical representation of the calculated calibration coefficients. On the left the calibration coefficients from peak integrals are plotted as a function of the heat in the peaks. On the right calibration coefficients calculated from steady-state values are plotted against the thermal powers used. Note the 10-log-scales on the x-axes.

Table 3: Measured time constants (calculated time constants in parantesis).

| Figure | τ / s | comment |
|--------|------------|---|
| 7 | 109 (83) | empty glass ampoule |
| 8 | 126 (87) | glass ampoule with 3.82 g copper powder |
| 10 | 150 (92) | glass ampoule with 5 g sand |

curve when evaluating the time constant; it is usually best to only use the curve from 80% to 20% of the maximum value.

When the measured time constants are compared with the theoretically calculated it is found the measured ones are 31, 45 and 63% higher than the theoretical values. There are probably one main reasons for this. The theoretical calculation does not take into account the extra resistance to heat flow that is present at the interfaces between the thermocouple plates and the ampoule holder and heat sink, respectively. According to the manufacturer (Melcor) the thermal interface pads used have a thermal resistance of approx. 0.05 K/W each. This is not much compared to the thermal resistance of approx. 2.5 K/W for the thermocouple plate itself, but as the plates were not clamped it is probable that there are some extra resistance, e.g. from an air gap of 0.01 mm on each side which gives a contribution of approx. . 0.9 K/W. An commonly used heat conducting adhesive for electronic components has a heat conductivity of approx. 0.7 W/m/K. With 0.1 mm joints of such an adhesive one will get an extra resistance of 0.3 K/W. As a conclusion, nearly all methods of fastening the TCP:s will give at least a 10% decrease in heat conductivity and a 10% larger time constant. Another factor that should also have been included in the calculation of τ is the heat capacity of half the thermocouple plate.

7.4 Temperature change in ampoule (isothermal heat sink)

The temperature rise (ΔT) in the ampoule when a steady thermal power (P) is produced there may be calculated from the following equation when the heat sink is isothermal (changes in the temperature of the heat sink are

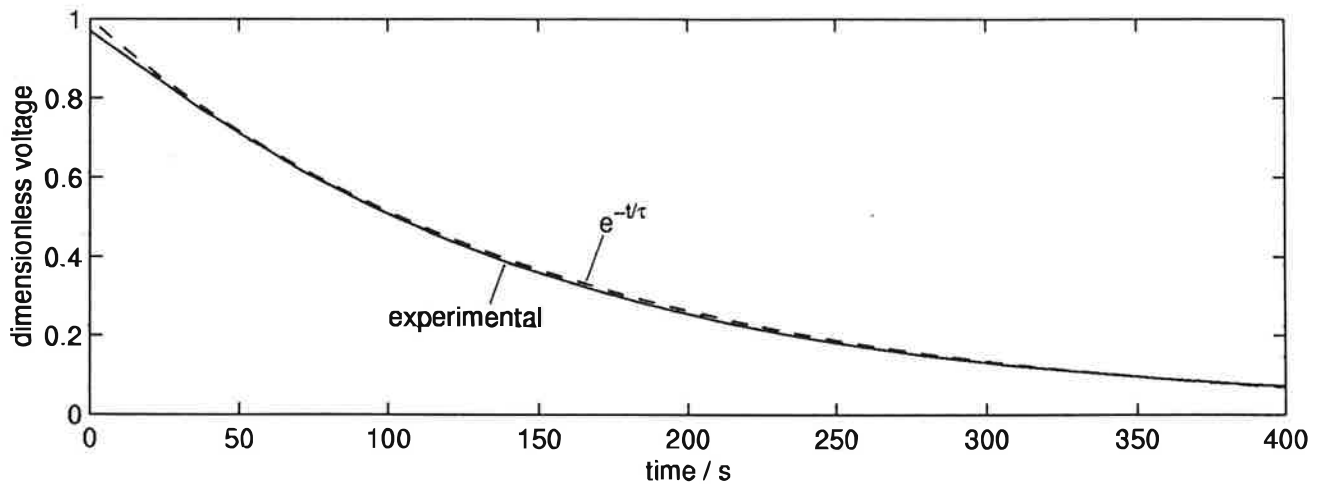

Figure 12: The measured decay curve and the curve fit according to Eq. 10.

dealt with in the next subsection):

$$\Delta T = \frac{P}{k_{12}} \quad (27)$$

With $k_{12}=0.401$ V/K the temperature difference will be $2.5 \cdot P$. The maximal thermal power that can be recorded with the PicoLog TC-08 used is 60 mV which corresponds to approx. 0.8 W which would give a temperature increase in the sample of 2.2 K. This is, however, the maximum. More typical is the highly exothermal hydration of 10 g standard cement paste will give a maximal thermal power of approx. 40 mW corresponding to a temperature increase of 0.1 K.

7.5 Temperature stability of the calorimetric block; time constant of block

The calorimetric block is an insulated heat sink. When the room temperature changes the temperature of the calorimeter will also change, but much more slowly. A time constant τ_{01} of the whole calorimeter may be calculated by solving Eq. 14 with $P=0$:

$$\tau_{01} = \frac{C_1}{k_{01}} = \frac{T_0 - T_1}{\frac{dT_1}{dt}} \quad (28)$$

The right hand side shows that τ_{01} may be evaluated as a ratio of the temperature difference between the ambient and the calorimeter, and the rate of change of the calorimeter temperature. For the present this has been evaluated from measurements of the temperatures in the room and in the calorimeter shown in Fig. 13 (same measurement as that shown in Fig. 10). After 8 h there is a slight temperature decrease in the calorimeter (difficult to see in the figure) caused by the temperature difference between ambient and the calorimeter that gives a time constant τ_{01} in the order of 10 h. The theoretically calculated value is 10 h (page 14). Another measurement in which there were some air gaps in the insulation gave a lower time constant in the order of 5 h. Note that although the polystyrene insulation is very good small defects in the insulation will drastically reduce the overall insulation.

Figure 13 also shows the effect of the evolved thermal power when it is compared with the thermal power plot from the same measurement in Fig. 10 from the same measurement. Looking at the third 1996 J two-step peak in Fig. 10 one sees that it corresponds to an increase in calorimeter temperature of approx. 0.3 K in Fig. 13. This gives a calculated heat capacity of the heat sink (C_1) of 6600 J/K, which compares well with the theoretical value of 5940 J/K.

8 The thermostating zone and heat exchangers

There is a fundamental difference between the heat exchangers in the S1-calorimeter and in an ordinary microcalorimeter: in the latter the heat dissipated in the thermostating zone goes to the thermostating bath and never reaches the calorimeter; in the S1-calorimeter this heat is conducted to the calorimetric block. The thermostating zone of the calorimeter is therefore of more limited value in this type of calorimeter.

8.1 Thermostating ampoules

An ampoule filled with hardened epoxy adhesive was conditioned at approx. 40°C. After that four different types of experiments were performed:

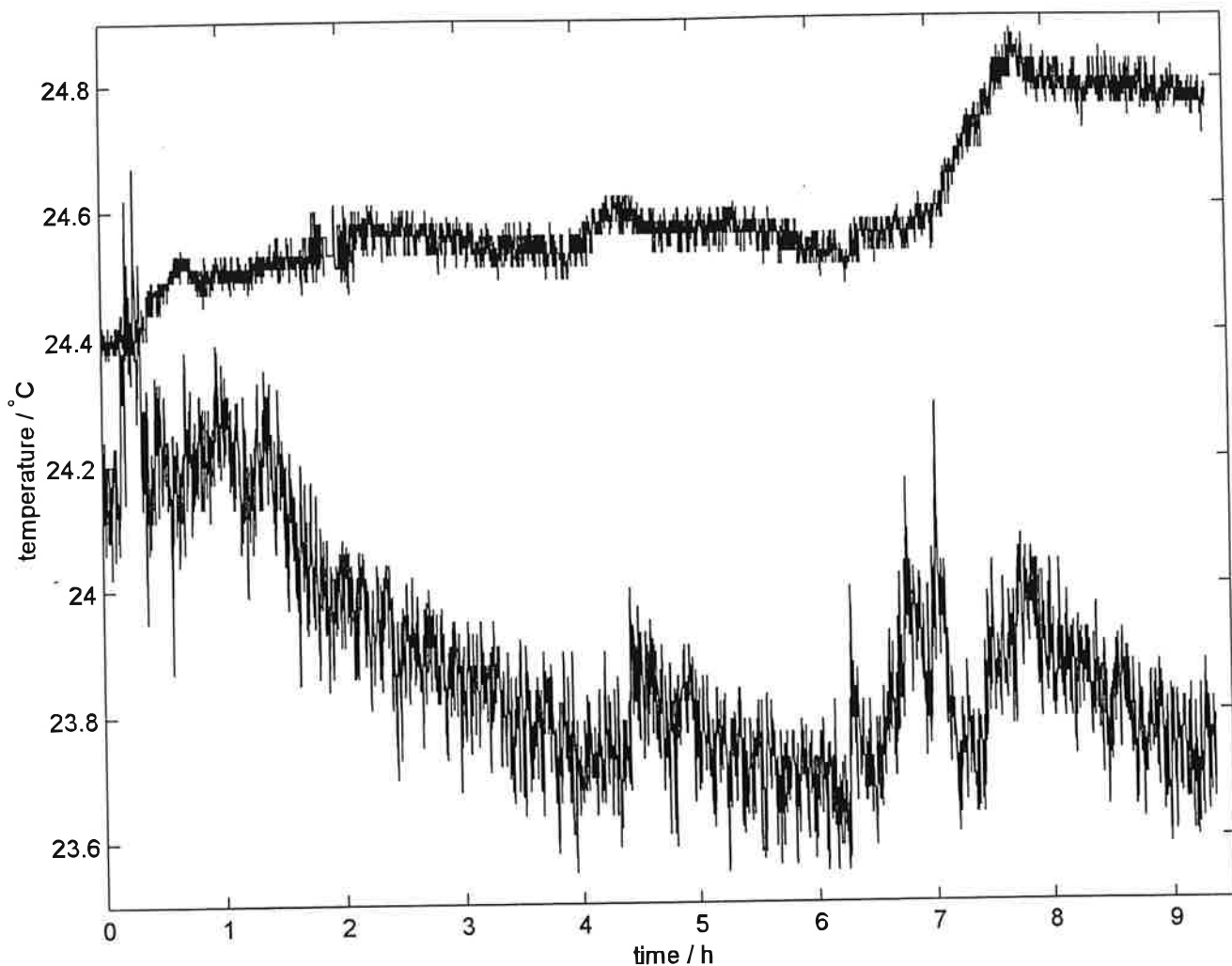

Figure 13: The ambient and calorimeter temperature during a measurement (the voltage output from this measurement is shown in Fig.10). The top curve with lower noise is the calorimeter temperature and the bottom curve is the ambient temperature. Note that the temperature in the calorimeter increases when there is heat produced in the calorimeter.

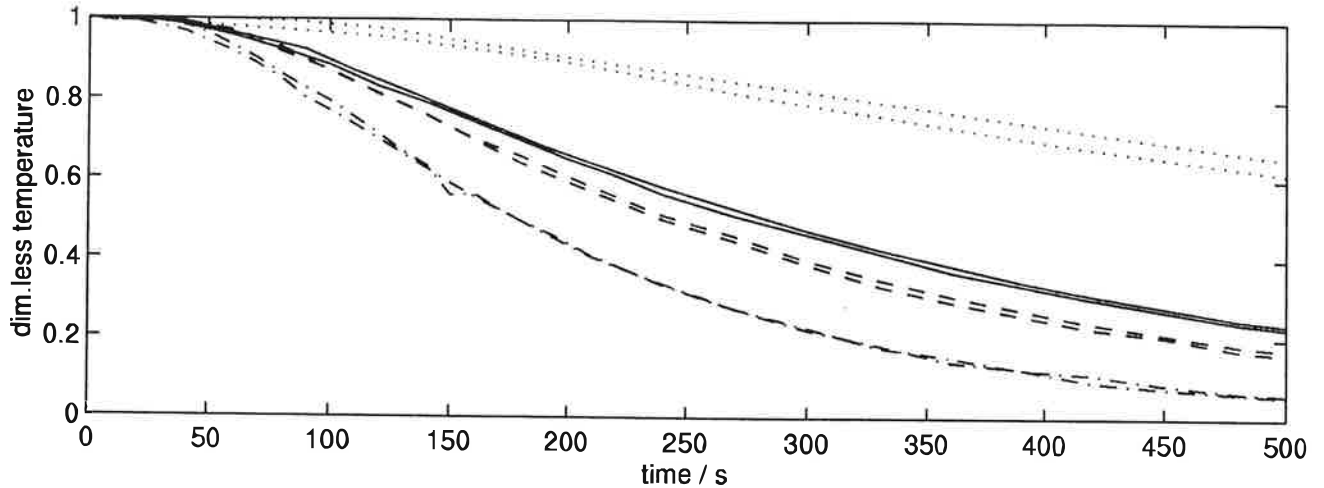

Figure 14: The result of measurements of the cooling of an epoxy filled glass ampoule under different conditions. The dimensionless temperature is 1 at the initial temperature of each measurement and 0 at the temperature of the ambient. Dotted: cooled in air; solid: in measurement position of calorimeter; dashed: in thermostating position; dash-dotted: in water.

1. The ampoule was put into the thermostating position of the S1-calorimeter which was at approx. 22°C.
2. The ampoule was put straight down into the measuring position of the S1-calorimeter which was at approx. 22°C.
3. The ampoule was left to cool hanging free in a room at approx. 22°C.
4. The ampoule was cooled by moving it with approx. 0.5 m/s in water at approx. 22°C.

During all these experiments the temperature in the ampoule was monitored with a thermocouple that was placed in the epoxy. Figure 14 gives the result. It is seen that the ampoule is thermostated at a slightly higher rate when it is left in the thermostating position compared to when it is in the measurement position. The difference is caused by the thermal resistance of the TCP etc. (k_{12}).

As the voltage is proportional to the temperature difference over the TCP Fig. 14 gives an idea of how much less disturbances one will get if one uses the thermostating position.

8.2 Thermostating perfused/injected media

When one perfuses or injects a gas or a liquid into the ampoule there may be disturbances caused by the medium having a different temperature than the ampoule. This disturbance will be less if the flowing media is thermostated for some time while flowing through a heat exchanger. It has not been tested how large this effect is for the S1-calorimeter.

8.3 Protecting the ampoule

The thermopiles and the ampoules are placed in a very protected environment in the S1-calorimeter as the heat sink surrounds it on all sides. This should decrease disturbances from the outside. It has not been tested how large this effect is for the S1-calorimeter.

9 Appendix A: the sand cast S1-1 calorimeter

Figures 15 and 16 show a S1-calorimeter made from two sand cast aluminum blocks. Sand casting is an inexpensive way of producing aluminum goods in long series. The thermal properties of the aluminum used for casting are good enough for the present purposes, but large pieces of cast metal may contain cracks which may be filled with the cooling liquid used for drilling holes in the metal. This liquid can be very difficult to get rid of. For the sand casting to be easy to perform the forms of the goods should be slightly conical. This is seen in the figures.

After the casting two of the surfaces were planed and two holes were drilled through the largest piece. The holes had a more narrow diameter of 22.70 mm in their upper parts than in their lower parts where the diameter was approx. 40 mm. The mass of the heat sink is approx. 9 kg and the two parts are fastened to each other with two screws (not seen in the figures). A thermal grease is used to decrease the thermal resistance between the blocks.

The two TCP:s (Melcor 30 mm × 30 mm CP 1.4-71-045L) were fastened with a silver filled heat conducting adhesive (Melcor, Trenton NJ, USA, TCE-001).

The insulation was made from 50 mm heavy duty extruded polystyrene with a density of 39 kg/m³ and a thermal conductivity of 0.036 W/m/K.

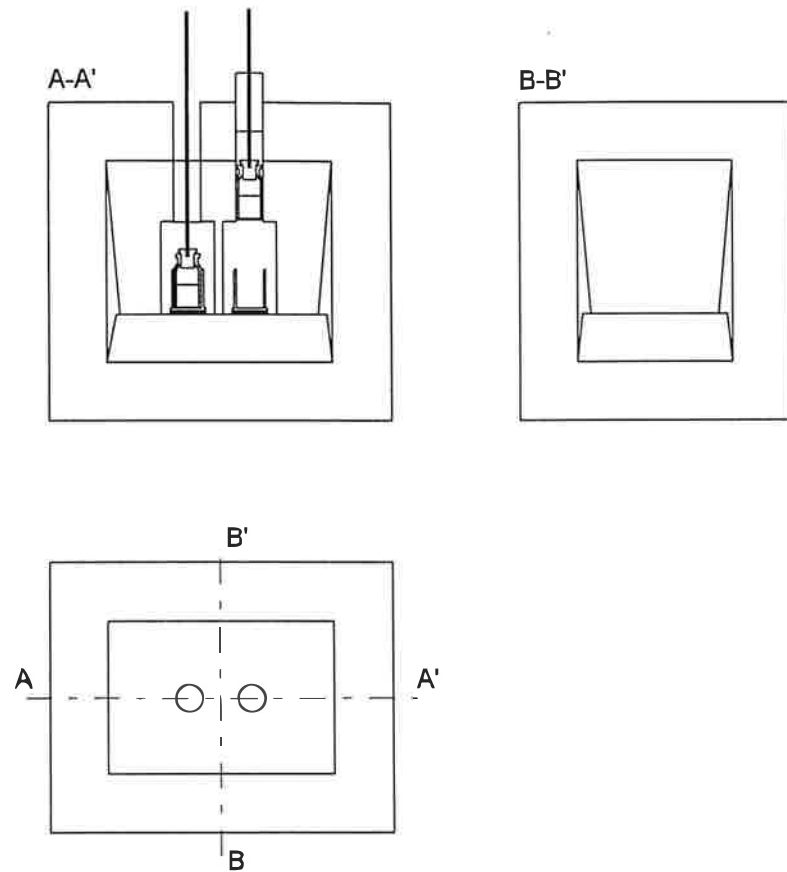

Figure 15: A drawing of the sand cast S1-1 calorimeter with two ampoules with heat exchangers (the left one in measuring position and the right one in thermostating position).

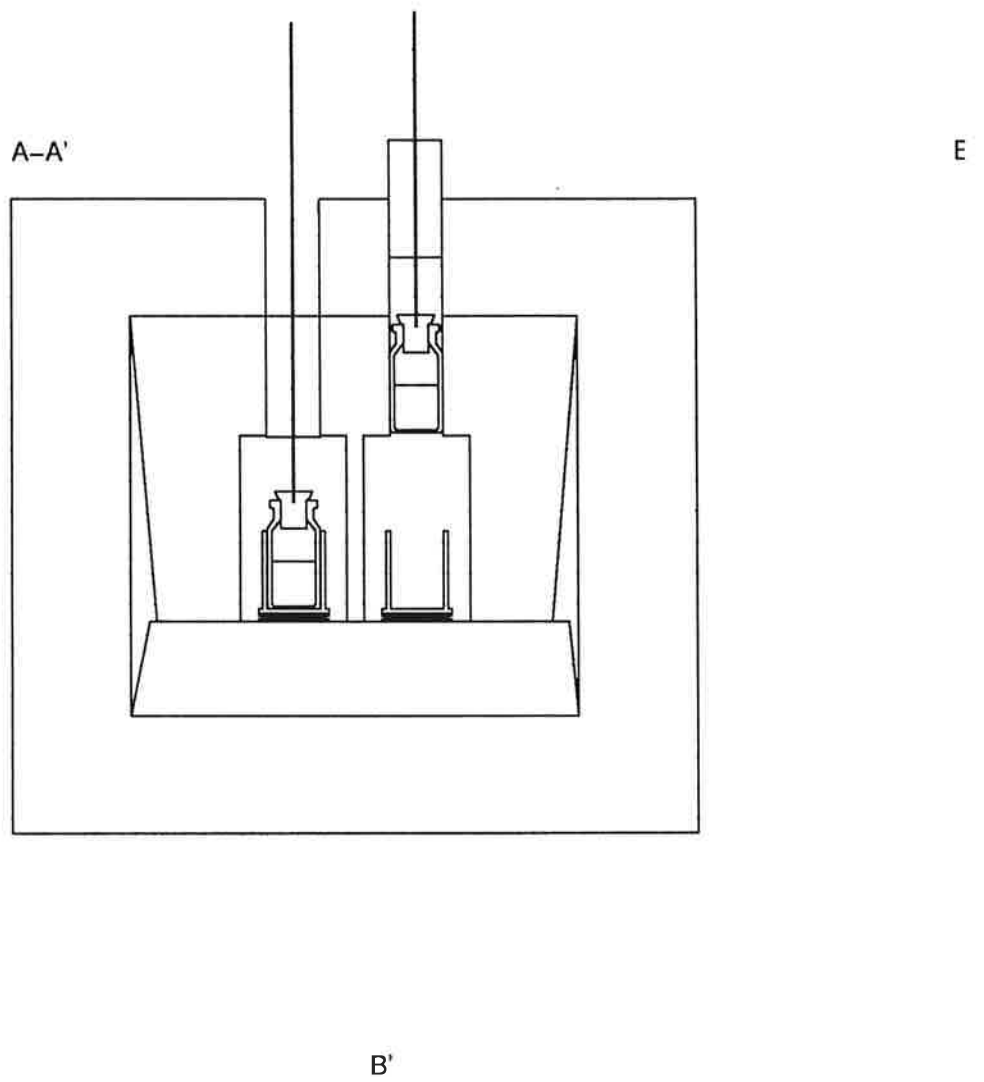

Figure 16: A close-up of the sand cast S1-1 calorimeter with two ampoules with heat exchangers (the left one in measuring position and the right one in thermostating position).

10 Appendix A: the S1-2 calorimeter made from four plates

Figure 17 shows a S1-calorimeter made from four 30 mm aluminum plates. Two holes are drilled through three of the pieces: the holes in the top plate has a more narrow diameter of 22.70 mm than the holes in the two middle plates with diameter approx. 40 mm. The mass of the heat sink is approx. 6.6 kg and the four parts are fastened to each other with two screws (not seen in the figures). A thermal grease is used to decrease the thermal resistance between the blocks.

The two TCP:s (Melcor 30 mm × 30 mm CP 1.4-71-045L) were fastened with a thermally conducting pad (Melcor, Trenton NJ, USA). These are meant to be used together with clamping that is not possible in the S1-calorimeter. They have, however functioned well without clamping.

The insulation was made from 50 mm heavy duty extruded polystyrene with a density of 39 kg/m³ and a thermal conductivity of 0.036 W/m/K.

11 References

- Melcor (1995) "Thermoelectric Handbook", Melcor, Trenton NJ, USA
Wadsö, L. (1998) "The S1 calorimeter; eight student experiments with a simple isothermal calorimeter", Building Materials, Lund University, Sweden TVBM-7123

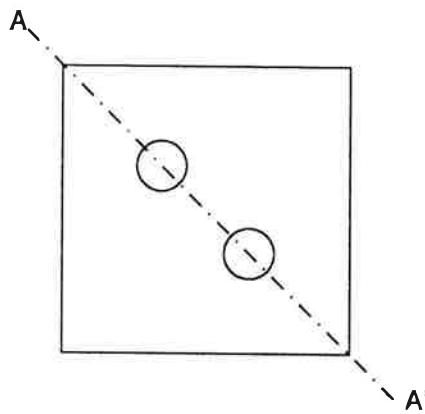
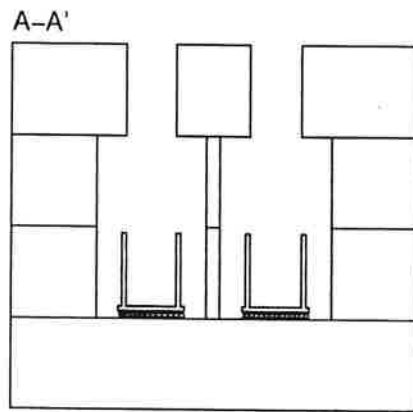

Figure 17: The S1-2 calorimeter (shown without insulation). Note that the holes are placed diagonally.