



LUND UNIVERSITY

Design of Safe Timber Structures - How Can we Learn from Structural Failures in Concrete, Steel and Timber?

Frühwald, Eva; Serrano, Erik; Toratti, Tomi; Emilsson, Arne; Thelandersson, Sven

2007

[Link to publication](#)

Citation for published version (APA):

Frühwald, E., Serrano, E., Toratti, T., Emilsson, A., & Thelandersson, S. (2007). *Design of Safe Timber Structures - How Can we Learn from Structural Failures in Concrete, Steel and Timber?* Division of Structural Engineering, Lund University.

Total number of authors:

5

General rights

Unless other specific re-use rights are stated the following general rights apply:

Copyright and moral rights for the publications made accessible in the public portal are retained by the authors and/or other copyright owners and it is a condition of accessing publications that users recognise and abide by the legal requirements associated with these rights.

- Users may download and print one copy of any publication from the public portal for the purpose of private study or research.
- You may not further distribute the material or use it for any profit-making activity or commercial gain
- You may freely distribute the URL identifying the publication in the public portal

Read more about Creative commons licenses: <https://creativecommons.org/licenses/>

Take down policy

If you believe that this document breaches copyright please contact us providing details, and we will remove access to the work immediately and investigate your claim.

LUND UNIVERSITY

PO Box 117
221 00 Lund
+46 46-222 00 00

Division of Structural Engineering
Lund Institute of Technology, Lund University

**Design of safe timber structures –
How can we learn from structural failures
in concrete, steel and timber?**

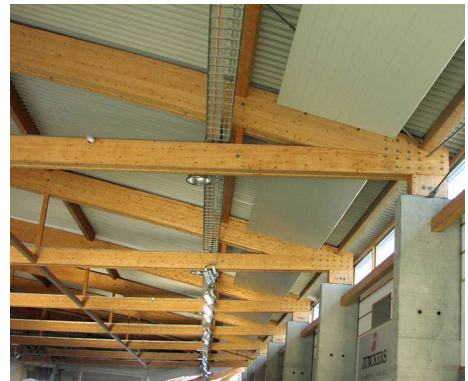

**Eva Frühwald
Erik Serrano
Tomi Toratti
Arne Emilsson
Sven Thelandersson**

Report TVBK-3053
Lund 2007

Report TVBK-3053
ISSN 0349-4969
ISNR:LUTVDG/TVBK-3053-SE (228)

**Design of safe timber structures –
How can we learn from structural failures in concrete,
steel and timber?**

Eva Frühwald
Tomi Toratti
Sven Thelandersson

Erik Serrano
Arne Emilsson

Division of Structural Engineering
Lund University
Box 118
SE 22100 Lund, Sweden

Telephone: +46 46 222 9503
Fax: +46 46 222 4212

www.kstr.lth.se

Preface

The present report documents research performed in a subtask for the joint Swedish-Finnish project “Innovative design, a new strength paradigm for joints, QA and reliability for long-span wood construction (InnoLongSpan)”, conducted 2004–2007. The project dealt with two main issues: (1) design of joints used in long span timber structures and (2) documenting reliability and developing quality assurance of large and demanding timber structures. This publication documents the results of the subtask to deal with reliability, where the objective has been to obtain in-depth information about causes for failures in wood structural systems. The purpose is to learn from such experience in order to improve control systems and education of timber engineers.

The background for the investigation is that some spectacular collapses of timber roof structures have occurred recently in the Nordic countries. After the project started a number of new cases where roof structures have collapsed in central Europe did occur during the winter 2005-2006.

The project was part of the Wood Material Science and Engineering Research Programme (Wood Wisdom), and has been supported by the following organisations and companies

In Finland

- TEKES (Finnish Funding Agency for Technology and Innovation)
- VTT
- SPU Systems Oy
- Finforest (Metsäliitto Cooperative)
- Versowood Oyj
- Late-Rakenteet Oy
- Exel Oyj

In Sweden

- Vinnova (Swedish Governmental Agency for Innovation Systems)
- Skogsindustrierna
- Casco Products AB
- SFS-Intec AB
- Limträteknik i Falun AB
- Svenskt Limträ AB
- Skanska Teknik AB

The contributions and funding from the above mentioned parties are gratefully acknowledged.

Lund, Espoo and Falun in Jan 2007

The authors

Contents

Preface	I
Contents	III
1. Introduction	1
1.1 Background	1
1.2 Aim	3
2. Experiences from previous failure investigations	5
2.1 General	5
2.2 Concrete structures	10
2.3 Steel structures	14
2.4 Timber structures	17
3. Present survey of failure cases – methodology	20
3.1 Definition of failure	20
3.2 Methods of collection of failure cases	20
3.3 Distribution of cases between countries	21
3.4 Presentation and evaluation of the investigated cases	22
4. Results and interpretation of the information collected	23
4.1 Primary cause behind the failure event	23
4.2 Type of building and span of primary structure	28
4.3 Type of structural element involved in the failure	30
4.4 Failure modes involved in the investigated cases	31
4.5 Age of the structure at the time of failure	31
5. How can we learn from previous failures?	33
5.1 General	33
5.2 Bracing	34
5.3 Tensile stresses perpendicular to grain	36
5.4 Moisture effects	38
5.5 Joints	39
5.6 Other issues	41
6. Summary and Conclusions	42
References	44
Annexe: Description of individual cases	47

1. Introduction

1.1. Background

Structural engineering is a classical subject and our general knowledge about performance and capacity of load bearing structures in buildings and infrastructure is nowadays on an advanced level. Modern computer based methods have made it possible to simulate the behaviour of both simple and advanced structures in a very sophisticated manner.

Against this background it is surprising that the frequency of structural failures occurring in practice is still quite high. During the winter 2005-2006 large amounts of snow accumulated on roofs in central Europe, and a great number (>50) of roof failures took place in Germany, Austria and Poland. Some of them led to fatalities and thus received great attention in media, where such events are often described as natural disasters like an act of God. The truth is however that structures should be designed to sustain extreme snow loads, as regulated in structural codes. The characteristic value for snow load is normally chosen as the annual maximum which would be exceeded only in average once per 50 years. Besides this, additional safety margins are provided in structural codes, which means that the structure should be able to withstand significantly higher loads than the 50 year return load, if it is correctly designed and built.

Numerous investigations of structural failures occurring in practice have been performed during the years (see e.g. [1-13]). Such investigations show convincingly that with few exceptions structural failures are due to human errors and almost never a result of unfavourable combinations of random events.

Failure cases can be found for roof structures made of all major building materials, concrete, steel and timber but media attention in Germany during 2006 focussed on the fact that one of the fatal failures, situated in Bad Reichenhall, had a wooden roof, see Fig. 1. The investigation showed that several circumstances contributed to the failure. The main structural elements were 2.87 m deep box girders made of glulam and wood panel products which were glued together. One significant reason for the failure was that the glue used had insufficient durability properties when exposed to humid climate, which was worsened by the fact that water leakage in the roof had occurred frequently during use. In addition, errors were also found in the statical design. Further details can be found in the annexe, see case 45. A number of people were killed in this accident and this has created a negative image for wood as a material. This is not logical since the reasons for the failures are very seldom the wood products as such, but rather deficiencies in the building process or human errors, brutally revealed during a winter with high snow load.

Spectacular collapses of timber roof structures have also occurred recently in the Nordic countries, fortunately without personal injuries. In January 2003, the glulam truss roof of a bicycle velodrome in Denmark, Ballerup Arena, collapsed, see Fig. 2. Two main roof

trusses fell down in spite of the fact that there was no snow load at all on the roof [14, 15]. The investigation [14] of the failure revealed that the main cause was multiple errors related to the structural analysis and conceptual modelling of the primary structure. This event created a heated debate in Denmark concerning quality assurance and control systems in the building process. Minor quality deficiencies of the glulam used in the structure were also revealed in the investigation, but these were found to be irrelevant for the occurrence of failure.



Fig. 1. Collapse of wooden roof for ice skating arena in Bad Reichenhall, Germany

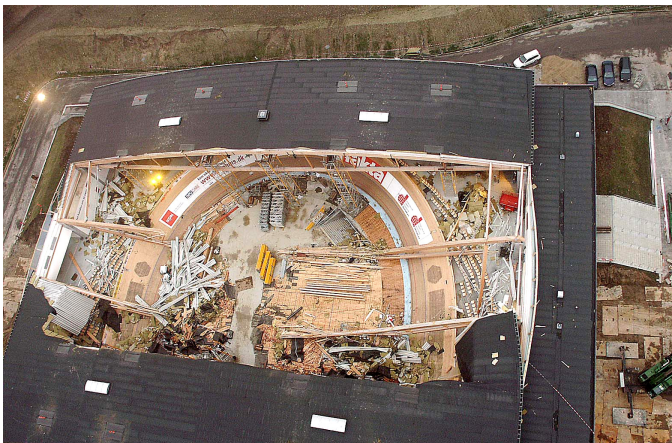

Fig. 2. Photo taken from above after the failure of the Ballerup arena roof.

The same winter 2003 another structural collapse took place in Finland. Four main roof trusses for exhibition hall B2 of Jyväskylä Paviljonki collapsed two weeks after the hall was opened for the public [15,16]. The snow load at the time of failure was about 50 kg/m² and there was no wind. The design snow load at this location is 200 kg/m² according to the Finnish code. The primary cause of failure was manufacturing errors leading to malfunctioning slotted-in steel plate joints in the main glulam trusses, see Fig. 3. The failure was initiated in a joint where only 7 out of 33 dowels were in place.



Fig. 3. Slotted-in steel plate joint where dowels were not mounted as intended.

1.2 Aim

It is clear that events of the type described above are quite negative for the competitiveness of timber on the construction market. The question is what can be done to reduce the risk for failure in timber structures in the future. The main hypothesis for the present work has been that quality assurance, control systems and improved training may be necessary, since the unwanted events are primarily related to human errors, ignorance and carelessness. To provide a basis for training and quality assurance of design and construction of buildings with wood as a structural material, a survey of failures in timber structures has been made. This report presents the results from this survey with an analysis of the underlying causes and associated conclusions and recommendations.

More specific, the objectives for undertaking the survey of building failures are to get a picture of

- the underlying reasons for observed failures
- which type of components are most prone to failure
- which failure modes are most frequent
- what can be done to avoid or reduce failures

The report has been produced as a part of a Swedish-Finnish project, with the objective to develop procedures for Quality Assurance of design and construction for buildings with wood as a structural material.

Many similar surveys for building structures in general and for all structural materials can be found in the literature. A summary of the findings from such studies is given in Chapter 2. A description of methodology and background for the survey of failure cases collected in the present project is presented in Chapter 3. Chapter 4 presents the results and their interpretation. In Chapter 5 the question “How can we learn from past failure experience?” is addressed. Summary and conclusions from the research are finally given in Chapter 6.

2. Experience from previous failure investigations

2.1 General

A number of surveys of structural failures have been reported during the years (see e.g. [1-13]). The purpose of these studies has been to quantify sources of error and to indicate their relative importance in the building process. A general conclusion from such studies is that failure almost without exception occurs due to human error.

A common feature for this type of investigations is that it is important to recognize that the statistics obtained from failure surveys are always incomplete and biased. Information about errors and mistakes is difficult to get, since the involved parties often have a strong interest to conceal facts. Furthermore, the data obtained in such surveys will usually not be representative since they are based on voluntarily reported and incomplete data. Still the experience gathered can be used to identify important technical and organisational problems in the building process [17].

Ellingwood [17] compiled results from a series of investigations during the years 1979-1985 to identify where in the building process errors occur. Some of the results from this together with some new results are given in Table 1. It should be noted that the classification of errors is not consistent between different investigators which makes the results difficult to compare. Also, different investigators may not interpret the same data in the same manner. However, in spite of these difficulties the results shown in Table 1 are quite consistent. The occurrence of errors are of the same order of magnitude for design/planning and construction respectively, with slightly higher frequency for the design phase. Failures due to material deficiencies or maintenance are relatively uncommon.

Table 1. Percentage of errors by the phase in which they were made.

Reference	Planning & design %	Con-struction %	Use/ main-tenance %	Other ^a %	Total %
Matousek [1]	37	35	5	23	98
Brand & Glatz [2]	40	40	-	20	100
Yamamoto & Ang [18]	36	43	21	-	100
Grunau [19]	40	29	31 ^b	-	100
Reygaertz [20]	49	22	29 ^b	-	100
Melchers, et al. [21]	55	24	21	-	100
Fraczek [22]	55	53	-	-	108 ^c
Allen [23]	55	49	-	-	104 ^c
Hadipriono [24]	19	27	33	20	99

^a Includes cases where failure can not be associated with only one factor and may be due to several of them

^b Building materials, environmental influences, service conditions

^c Multiple errors for single failure case

A comprehensive failure survey was performed by Matousek & Schneider [1], who investigated 800 cases from different sources. Their findings are grouped under three subsections:

- Facts about the damage
- Causes of the damage
- Consequences of the damage

Concerning the factual circumstances it was found that the costs of the damage in many cases were rather modest (in about 50 % of the cases the cost for the damage was less than 20 000 CHF in the 1970ies). The building phase, in which the damage occurred/was detected, was also reported as (percentages out of 692 cases)

- During construction: 58 %
- During use: 39 %
- During rebuild/destruction: 3 %

This confirms the findings from other investigations that failures occur more frequently during the construction phase than later. For those failure cases where people were killed or injured the percentage of cases occurring during construction is even higher (65-70 %). However, the fact that the error was detected in the construction phase does not necessarily imply that the error was initiated by inadequate construction methods.

For the cases where damage concerns load bearing structures (384 cases out of 800) 63 % were classified as sudden failures and 37 % as unacceptable conditions. A further subdivision among these cases is given in Table 2.

Table 2. Distribution of type of damage for load bearing structures in percentages by number of cases [1].

	Type of failure/damage	%
Sudden failures	Loss of equilibrium	13
	Failure with collapse	29
	Failure without collapse	11
	Other types of failures	10
	Subtotal	63
Unacceptable conditions	Excessive cracks	16
	Deflections and change of shape	7
	Errors in dimensions and support conditions	8
	Other unacceptable conditions	6
	Subtotal	37
	Total	100

Matousek & Schneider [1] identified for the investigated cases the initiating unfavourable influence(s), which caused the damage. An interesting question is whether these influences had been considered or not in the building process. This is shown in Table 3. It can be seen that the initiating influence had not been considered or wrongly considered in almost 75 % of the cases.

Table 3. The way damage-initiating, unfavourable influences were taken into account in the building process [1].

Type of consideration in the building process	Percentage by number of 723 damage cases.
No consideration	26
Incorrect consideration	26
Insufficient consideration	16
Considered, but risk accepted	22
Type of consideration unknown	10
Total	100

For those cases where errors were made in planning and design, see Table 1, a further analysis of the character of the mistakes was performed. The result of this is shown in Table 4. It is interesting to note that a majority of mistakes is related to conceptual errors and structural analysis. Incorrect assumptions or insufficient consideration of loads and actions was found to be a common type of error.

Table 4. Characteristics of errors made in the planning and design phase [1].

Type of error	Percentage by number of 295 damage cases.
Conceptual errors	34
Structural analysis	34
Drawings and specifications	19
Work planning and preparation	9
Combinations	4
Total	100

These findings were also confirmed in the investigation by Walker [26], whose findings were also presented in [21]. Results concerning prime causes of failure from [26] are shown in Table 5. From this table it is again confirmed that failures are primarily (90 %) caused by gross human errors and cannot be avoided by increasing the formal safety level in structural design. Inappropriate appreciation of loading conditions and/or real behaviour of the structure was found to be the prime cause in almost one third of the failure cases investigated in [26].

Results from numerous investigations of the type described above have led Kaminetsky [6] to conclude that all failures are human errors and that they can be divided into three categories:

1. Errors of knowledge (ignorance)
2. Errors of performance (carelessness and negligence)
3. Errors of intent (greed)

The first one can be improved by training and education, but training will not help for type 2 and 3. In all three cases improved control and supervision imposed by the client in the building project can help, but experience shows that this is a demanding task, since many control systems do not function as intended.

Table 5. Prime causes of failures from an investigation by Walker [26].

	Cause of failure	%
Prime causes which can <u>not</u> be counteracted or avoided by increased safety factors in structural design. (Gross human errors which could be reduced by checking and supervision)	Inadequate appreciation of loading conditions or real behaviour of structure	36
	Inadequate appreciation of loading conditions or real behaviour of connections	7
	Excessive reliance on construction accuracy	2
	Serious mistakes in calculations and drawings	7
	Inadequate information in contract documents and instruction	4
	Contravention of requirements in contract documents and instruction	9
	Inadequate execution of erection procedure	13
	Unforeseeable misuse, abuse and/or sabotage, natural catastrophe, deterioration	7
	Others	5
	Subtotal	90
Prime causes which can be remedied by increased safety factors in structural design. (Unfavourable random effects lead to failure)	Unfavourable load variation or combination (related to partial factors for loads)	0
	Inaccuracies in design assumptions of support conditions, hinges etc, (related to model uncertainties)	3
	Deficiencies in materials and workmanship (related to partial factors for resistance)	4
	Foreseeable deterioration	3
Subtotal	10	
Total		100

The results described above are mostly of general nature concerning the functionality of the building process. Eldukair & Ayyub [27] studied about 600 structural and construction failures from the US Engineering News Record during the period 1975-1986. Among other things they classified the cases according to the material used in the failed elements. The result from this is shown in Table 6, where it can be seen that reinforced concrete is very dominating with a share of 86 % among the cases in this review. Steel contributed to 9 % of the cases, while timber elements were involved in only 3 % of these cases. However, these figures should be interpreted with great care. Even if timber is extensively used in the US building industry, it is very likely that timber is inadequately represented in this survey. Buildings with timber may not appear in a representative manner in the Engineering News Record, since a large number of buildings where timber is used are not “engineered”. Still this survey indicates that the risk associated with timber construction at least is not higher than for other materials.

Many investigations found in the literature deal with structures made of a particular material, notably concrete, steel and timber. Some results from such investigations are summarised below.

Table 6. Classification of material of failed elements [27].

Type of material in failed elements	Failure cases %
Reinforced concrete	86.4
Steel structures	9.0
Rock and earth materials	5.8
Timber elements	2.8
Glass cladding	1.8
Prestressed concrete	1.3
Precast concrete	0.8
Others	1.7
Total*	109.6

* For some cases more than one material was involved.

2.2 Concrete structures

Specific information about damage in concrete structures has been published in [2, 3, 6, 22 and 23]. Concrete structures can be divided into cast-in-place structures and precast structures. The available failure information mainly concerns cast-in-place concrete.

Types of damage and causes for damage can be divided into the following categories:

- Material quality
- Work execution
- Structural design and detailing

Damage related to the material can be defective ingredients in the concrete mix, wrong proportions between the mix constituents, improper amount of admixtures, etc. A classical example is impurities in aggregate and sand used in the concrete mixture, such as organic material, clay and salts. Also impurities in the water may lead to concrete with inferior quality. A well known Swedish example is the Öland Bridge where brackish water and inferior aggregate from local sources were used in the concrete mix. This led to severe durability problems so that the bridge had to undergo significant repair work only few years after it was built.

Problems with cement may be unsuitable storage leading to hydration before mixing. Inadequate cement type can lead to damage from thermal stresses created by heat of hydration and mixtures with other type of binders may lead to inferior quality.

Damage related to work execution includes inadequate vibration, placement of reinforcement in wrong position, deformation of formwork, inadequate curing conditions of the concrete after casting etc. Furthermore, damage during construction may occur due to premature removal of shoring, too weak shoring, insufficient lateral bracing of shores etc., see also [27] and [28]. An example of catastrophic failure due to premature removal of shoring is shown in Fig. 4. Failure of the supporting system during casting lead to a progressive collapse initiated by punching shear failure in a flat slab. The collapse caused the death of fourteen construction workers.



Fig. 4. Progressive failure of multi-storey concrete building due to premature removal of shoring, 1973, Virginia, USA.

American experience shows that punching shear failure in flat slabs is common in many cases with severe consequences [6]. Punching shear often occurs without warning which explains that many people were killed or injured in the cases recorded.

This type of failure is often caused by improper procedures for form removal and reshoring or by inferior concrete quality due to casting in cold weather. Another reason found was that column caps, shown on drawings, were omitted in construction. Failures were also caused by inadequate detailing of column supports at slab corners or in the vicinity of slab openings.

Damage or failure in reinforced concrete is also often caused by improper detailing of expansion joints, brackets, dapped beams, openings, support areas, joints etc. Occasionally, this can lead to catastrophic failure but more often to undesirable cracking of the structure. An example with very severe economical consequences was the collapse of the Sleipner A offshore platform in 1991, see Fig. 5. The platform was to be supported on the seabed on a concrete gravity base structure consisting of 24 cells with

total base area of 16000 m². Errors in detailing of the reinforcement in the vertical joints between the concrete cells lead to shear failure during the operations to sink the platform to the seabed, see e.g. [30]. The economical loss from this detailing error was estimated to 700 Million US\$, the most expensive shear failure in history.

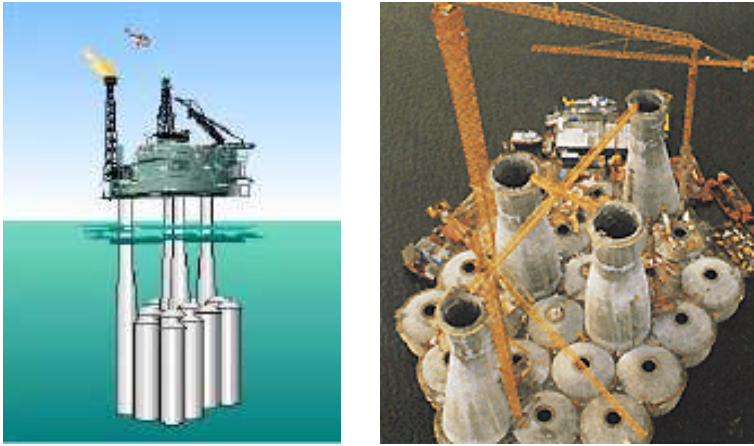

Fig. 5. The Sleipner A offshore platform

For precast concrete, which is produced under good conditions usually in a plant or a casting yard, the control of concrete quality is much better than for cast-in-place concrete. The most common problems with precast concrete systems are the connections which are more difficult to arrange. For prestressed concrete elements, problems unique to prestressing are also encountered. Local shear failures in support areas, often triggered by restrained movements and rotations are frequent causes for failure or loss of serviceability.

Understanding the structural behaviour of reinforced and prestressed concrete is sometimes quite difficult. For unusual structures or unusual conditions, this can lead to problems. Two new prestressed concrete bridges for a tram line in Stockholm were closed in 2002 due to shear cracks in the webs of the prestressed box section. These shear cracks were probably not risky with regard to structural collapse, but uncertainty about their nature lead to closure of the tram line and extensive media coverage.

Paradoxically enough, the problem for these structures was that the traffic loading from trams is very low. This means that the load under serviceability conditions is close to the ultimate load. Design of the structure for shear in the ultimate limit state therefore gives a low amount of shear reinforcement, which is not sufficient to limit cracks under service conditions.

An example of an innovative concrete structure is the terminal building at Charles de Gaulle airport in Paris, which was built with an elliptical reinforced concrete shell roof. The roof suddenly collapsed in May 2004, 11 months after it was opened, killing four people, see Fig. 6. The official investigation identified four errors in design and construction of the unusual type of structure.

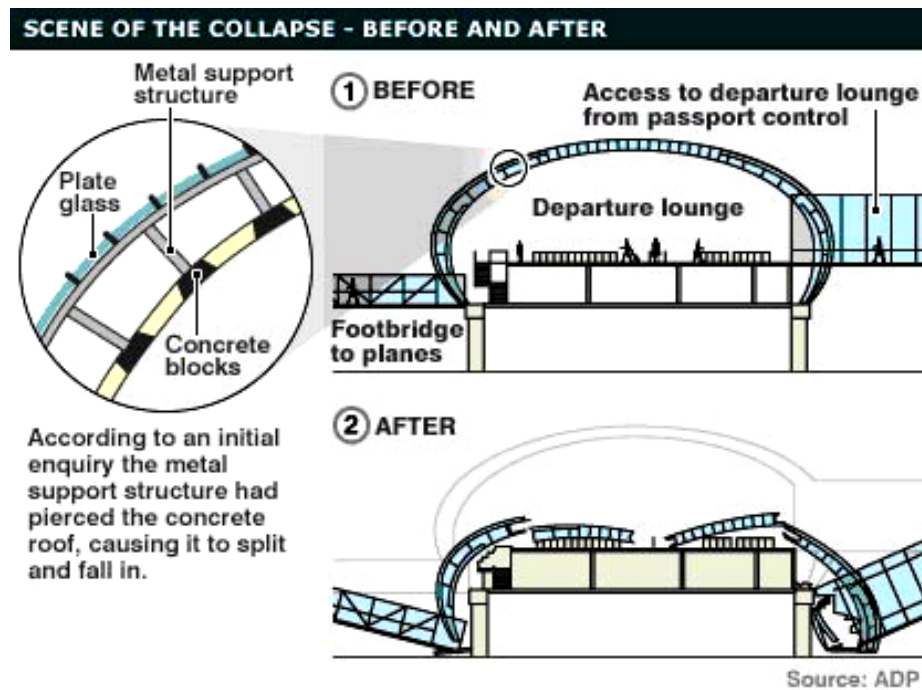

Fig. 6. Collapse of terminal roof at Charles de Gaulle airport in Paris

2.3 Steel structures

Specific information about damage in steel structures is more difficult to find than for concrete structures, but overviews can be found in references [5], [6] and [10]. Structural steel is produced under well controlled manufacturing operations, and failure due to deficiencies directly related to material strength almost never occurs [6]. But brittle fracture failures of steel are occasionally recorded mostly for bridge structures exposed to low temperatures and impact loading. Brittle failures of this type most often occur in welded thick plates made of steel with low toughness properties.

According to Kaminetsky [6], the most frequent reasons why steel structures fail are

- Insufficient temporary bracing during construction
- Errors in design/construction mainly of connections and details
- Deficient welding
- Excessive flexibility and non redundant design

Building structures of steel are often of skeletal type, in the form of an orthogonal assembly of elements. The horizontal stabilisation of such systems in the finished building relies on vertical truss type elements or solid shear walls together with horizontal floor diaphragms. In certain phases during construction, before such stabilising elements have been installed, the system is unstable unless temporary bracing is provided. Failures frequently occur during construction caused by missing or insufficient bracing of this type.

Failures caused by incorrectly designed or constructed steel connections are quite common. A well known example of structural failure of a steel structure due to errors in detailing of steel connections is the collapse of the walkway in the Hyatt Regency hotel in Kansas City in 1981. The walkway, which was suspended on steel rods in the lobby of the hotel, collapsed suddenly leading the death of 113 persons and injury of many others. The reason for the failure was incorrect design and construction of the connection between the steel rod and the cross beam in the walkway structure. The original design of this detail is shown in Figure 7, together with the as-built detail. Even the original design can be criticised, since the flanges of the channel profiles are too weak to resist the pressure from the nut carrying the load from the walkway. The actual as-built arrangement means that the contact pressure in the detail is doubled compared to the original design, which had been overlooked when the change was made. According to [6] the actual capacity of the connection was only slightly higher than the dead load from the structure. The collapse occurred when the walkway was crowded by people watching a dancing competition on the lobby floor beneath the walkway.

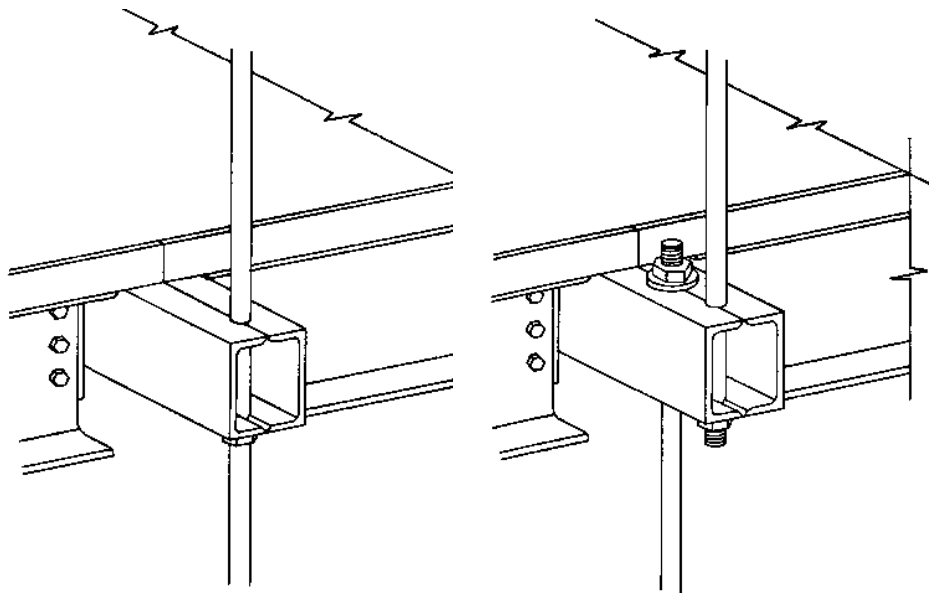

a) Original design of detail

b) As-built detail

Fig. 7. Connection detail leading to fatal collapse of walkway in Kansas City Hyatt Regency hotel 1981.

Another source of error is defective welding connections. The quality control of welding on the building site is difficult. Deficiencies in welding are also caused by using steel qualities with insufficient weldability leading to brittle fracture often in combination with low temperatures.

Steel structures are often very slender and sometimes very flexible. The deflections are often underestimated in design for structures such as light-weight trusses and open web roof joists. Excessive deflections of flat roofs lead to ponding and thus increased load from water, which in several cases have led to collapse of the roof [6]. The consequences of the failure are also large in systems with low degree of redundancy.

Oehme & Vogt [10] investigated about 600 cases of failure in structural steel buildings, bridges, masts, towers, chimneys, cranes etc. They identified the following categories of structural failure

- Vibration induced failures
- Stability type failure
- Fatigue and brittle failure
- Corrosion damage
- Failures due to errors in detailing and connections

Vibration induced failures are often related to dynamic effects from wind excitation. Well known examples are the collapse of Tacoma Narrows Bridge in 1940 as well as steel chimneys failing due to vortex shedding. This problem has been addressed in new guidelines for design and is usually avoided in modern construction.

Instability phenomena are often decisive for the dimensions of steel structures and special measures for stiffening and bracing are then needed. Consequently, stability induced failures are quite common for steel structures. As an example, in the 1970ies a series of collapses took place around the world for box girder bridges of steel due to insufficient buckling resistance of the compression zone of the box girder sections. Fig. 8 shows one of these bridges. The box girder, which was built by cantilever construction technique, suddenly collapsed when the last element was installed at the end of the cantilever. Thirteen construction workers were killed in the accident. After these events thorough investigations were made and new design guidelines were developed to better handle the buckling problems in this type of structure, see e.g. [32].

A special feature for steel structures is their sensitivity to fatigue under dynamic loading as well as to corrosion. Many damage cases can be attributed to these phenomena.

Historically, certain structural problems leading to failure have appeared under certain time periods. When these problems have caused spectacular failures a lot of attention has been given to perform research and investigations. The results from such efforts have later been disseminated to the practice in the form of stricter control and regulations reducing the particular problems significantly.



Fig. 8. Collapse of steel box girder during cantilever construction, Rheinbrücke, Koblenz, 1971, Source: Ref. [31].

But serious failures still take place in steel structures due to gross human errors. A well known example is the collapse of the flat roof for an exhibition hall in Chorzow, Poland, in winter 2006, where more than 60 people were killed. The main load-bearing elements in the roof structure were light-weight steel trusses. The exact cause of this collapse is not yet known, but it has been reported that there was high snow load on the roof at the time of collapse. Furthermore there had been warnings in the form of large deflections and “bulging” of the roof under snow load also during previous winters. Several persons were arrested under suspicion for negligence in maintenance and supervision of the building.

2.4 Timber structures

Rather few cases related specifically to timber structures are found among the failure investigations published in the literature. The conclusion from this is not necessarily that timber structures are “safer” than structures from other materials. A more probable explanation is that failure cases related to timber structures have been included only to limited extent in the data material collected in previous investigations.

However, special investigations of failures in timber structures are found in references [7-9]. Dröge & Dröge [7] describe 31 cases in a rather detailed manner. From their investigation the following technical causes of damage which occur in timber structures can be identified.

- Inadequate behaviour of joints
- Effects of moisture exposure (imposed strains, shrinkage)
- Poor durability performance
- Inadequate bracing of structural system
- Inadequate performance of material and products
- Inadequate appreciation of loads

In [7] the data are too sparse to draw any quantitative statistic conclusions about the types of problems encountered in timber structures, but some indications can be deduced.

Reliable joints in timber structures seem to be problematic and several cases are reported where defective behaviour of joints was found. In many of these cases a contributing effect was also shrinkage effects in the wood, which was built in with too high moisture content compared to the final equilibrium moisture content in the completed building. Gross design and construction errors have also been reported in connection with structural joints, such as the catastrophic failure cases shown in Figures 2 and 3.

Many cases are also found where inadequate consideration of climatic effects has lead to unacceptable effects for timber structures. The most common problem is cracks perpendicular to grain in wood elements due to moisture induced strains in wood elements subject to internal or external restraint. An example is shown in Figure 9, from a case where numerous longitudinal cracks in the main glulam roof girders occurred

when the building (sport hall) was 2 years old. The cracks were mainly caused by rapid drying of the wood after it was finished. Particularly heavy cracking took place in that part of the roof where installations of hot water tubes were present. The cracks led to increased and nonuniform deflection of the flat roof, which in turn led to ponding during a heavy rain. The roof did not collapse but had to be temporarily supported for safety reasons.



Fig. 9. Longitudinal through crack in glulam roof girder due to shrinkage effects. Hot water piping in the vicinity of the girder contributed to fast drying. Source: Ref. [7].

The risk for biological deterioration must always be considered when the structure is exposed to high moisture conditions. Damage from rot and similar effects is however a slow process and catastrophic failure can usually be avoided by detection before this happens. However, in some cases this type of deterioration may take place in hidden, nonventilated locations and remain undetected.

Inadequate performance of wood material and wood products seems to be rather rare as primary cause for failure or damage. In connection with thorough investigations of damaged structures, however, deficiencies in quality of wood products have sometimes been observed, see e.g. [7] and [15]. Colling [9] describes two cases where the main cause was found to be inadequate material quality. In one case with collapse of glulam roof beams the failure was attributed to deficient quality of the glulam, with too weak finger joints (most significant reason, see Fig. 10), too much knots in the lamellae and wrongly positioned butt joints in the glulam layout. Colling [9] reports on another case where bending failure occurred in solid timber with very large slope of grain not allowed by the grading rules for structural timber. Nevertheless, these types of deficiencies are seldom the main cause of failure in the cases documented in literature.

In some cases inadequate appreciation of load effects on the structure have caused failure. Errors related to load effects can sometimes be seen as design errors in that the engineer has not considered a certain load component or has had a wrong picture of the force transfer in the structural system. Occasionally, errors can be related to structural

codes, which may underestimate snow or wind loads, see e.g. [35]. Such events are however quite rare. As for concrete and steel structures the vast majority of damage also in timber structures can be attributed to human mistakes.

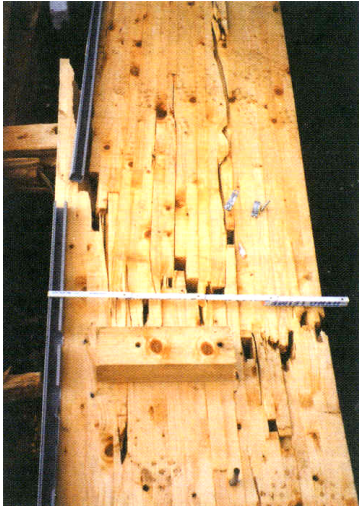

Fig. 10. Failed glulam beam due to low quality finger joints. The failure line is staggered and coincides with the finger joints. Source: Ref. [9].

3. Present survey of failure cases - methodology

As mentioned in the introduction a survey of failures in timber structures has been made within a Swedish-Finnish project. The main purpose is to get background information in order to develop procedures for Quality Assurance of design and construction of buildings with wood as a structural material. In this chapter the methodology behind the survey is presented.

3.1 Definition of failure

The concept of failure considered in this project is mainly related to the ultimate limit state and not to loss of serviceability. Thus, failures are defined as events which directly or indirectly have or could have implied risk for human lives. Examples are direct collapses of structures, local cracking, crushing or degradation which can be expected or suspected to have adverse effects on the safety of the structure. Events which are outside the scope of this project are e.g. vibrating floors, excessive deformations, moisture movements and building physical effects, such as growth of mould and fungi, which clearly do not have any consequence for the safety of the structure.

3.2 Methods of collection of failure cases

A total of 127 failure cases were included in the survey. The data material used in the project was collected in different ways. In about half of the cases, direct information on failure cases including documented investigations of the failure events and their causes were provided by project participants who had been assigned to investigate failures. Investigation reports were obtained from SP, VTT, Finnish Accidents Investigation Board and experts, see Table 7. The rest of the cases were taken from literature, where failure cases and analysis of their causes have been presented mostly based on investigation work performed by others. This makes the information more indirect, leading to increased risk of misinterpretation. It is understood that first-hand information from investigation reports is most reliable, but to broaden the sample size, relevant cases found in the literature were included when they were deemed to be sufficiently documented. Unclear cases were excluded. Thirty-eight cases were extracted from 7 different books or professional journals. These cases were mostly from Germany (30 cases) and United States (13 cases). Twenty-eight cases were taken from two diploma theses from Norway and Finland, prepared by Skaug [35] (17 cases) and Törmänen & Leskelä [36] (11 cases), respectively.

As in other failure surveys presented in the literature, see Chapter 2, the sampling process is difficult, since many failures are either not investigated or the results from investigations are not publicly available. For instance, during the snowy winter 2005/2006, about 50 failure cases in Germany and Austria were found in newspapers and on the internet. However, it has not been possible to get more information on investigations carried out. It is believed that in some cases investigations were not made

at all, since the high snow load was immediately judged as being the cause of failure. Thus, the results from the present survey, like other failure surveys performed before this one, cannot be interpreted as a random sample representative for the building practice.

Table 7. Source of cases used in the present study.

Source		Number of cases	Percentage of cases
Direct (investigation report)	SP	18	14.2
	VTT	11	8.7
	Finnish Accidents Investigation Board	7	5.5
	Experts (7)	25	19.7
Indirect information	Books (7)	38	30.0
	Diploma theses (2)	28	22.0
Total		127	100

Even if the number of cases from a statistical point of view is limited and not representative for any defined population, the present investigation contains, as far as the authors know, the largest collection of failure cases for timber structures which has been compiled. Therefore, a quantitative evaluation of the 127 cases will be presented below. But it must be stressed that the quantitative results should be interpreted with care, since the reasons for failure depend on the time period when the building was erected, country, type of building etc. Furthermore, it must be kept in mind that the quantitative figures given below can only indicate certain trends, and they are in principle only representative for the sample (127 cases) in this study. Another sampling might give different results.

3.3 Distribution of cases between countries

The distribution of the 127 cases between countries is shown in Table 8. The study comprises mostly failure cases from Scandinavia (Sweden, Finland and Norway) as well as Germany and United States. The reliability of the information related to the country. For example, the Swedish, Finnish, Danish and Czech cases are all obtained as direct information, whereas only two of the German cases are direct information. The rest of the German cases and the American cases have been found in the literature. However, also for some of the literature cases, the information was provided in written form by the investigating expert himself, thus increasing the reliability of the information.

About one fourth of all the failure cases are from each of the countries Sweden, Finland and Germany. This does not mean that buildings fail more often in those countries, but only that the sampling process was easiest for those countries, as the Finnish project partner (VTT) sampled the Finnish cases, two Swedish project partners sampled Swedish cases and another Swedish project partner conducted a literature survey with mostly German literature, where a number of cases for timber structures are presented. As

described in section 2.1 previously published failure investigations contain very few cases related to timber structures.

Table 8. Failure cases according to countries.

Country	Number of cases	Percentage of cases
Sweden	31	24
Finland	30	23
Norway	16	13
Germany	33	26
United States	13	10
Denmark	2	2
Czech Republic	1	< 1
Great Britain	1	< 1
Total	127	100

3.4 Presentation and evaluation of the investigated cases

A short summary of each of the investigated failure cases is given in the Annexe to this report. This summary gives the most basic facts about each case together with an evaluation of the main reason for the failure event as it is interpreted by the investigator or reporter. In many of the cases, the authors of this report have given their own comments to the case.

Quantitative evaluation of the cases in the database together with some general findings is presented in the next chapter. The cases presented in the Annexe are numbered and references to specific cases are sometimes given below.

4. Results and interpretation of the information collected

4.1 Primary cause behind the failure event

For each case in the study one cause or sometimes several causes of failure were identified. The different types of errors were classified with respect to the following nine categories:

1. Wood material performance:

By this is meant that the materials used in the product have been of poor quality in relation to practice. An example is larger knots than permitted in glulam laminations.

2. Manufacturing errors in factory:

This relates to manufacturing errors, which should have been detected in the production according to practice and internal quality control. An example is poor bonding quality of finger joints in glulam.

3. Poor manufacturing principles:

This means that the basic principle used for manufacturing the product has been poor. However, the poor principle has been used as intended.

4. On site alterations:

Here, alterations of the structure have been made on site. These alterations have led to the failure. Note that it is often difficult to know whether these alterations were intended from start, or made on site for practical reasons.

5. Poor design/lack of design with respect to mechanical loading:

This means that the failure was due to errors in the strength design of the structure (design method). In this category only mechanical loading is considered.

6. Poor design/lack of design with respect to environmental actions:

This means that the failure was due to errors in strength design but the failure was caused by mechanical loading in combination with environmental actions (e.g. drying cracks, shrinkage effects and durability damage)

7. Poor principles during erection:

Failures, which are due to poor handling at the erection of the structure, are grouped in this category.

8. Overload in relation to building regulations

9. Other/unknown reasons

In 44 out of the 127 cases, the failure could not be related to one single error but to two or three types of errors, which sometimes could be seen as primary and secondary causes. For each case where multiple errors were identified the evaluator made an estimate of the weight of each type of error causing the failure event. As an example, in case No. 72 shown in Fig. 11, a ceiling in a supermarket fell down due to insufficient

withdrawal capacity of the nails fastening the 50 x 50 mm² wood battens for the ceiling to the bottom chord of the roof truss. The designer had prescribed three nails in each joint, but only two were provided during construction. One reason for this was that the designer did not realise that there was not enough space – as given in relevant standards – for three nails in the contact surface between the battens and the bottom chord of the truss. In this case the failure was classified as 0.5 (50 %) due to poor manufacturing principles and 0.5 (50 %) due to design error. In cases where only one cause was identified, the weight for this error type was set to 1.0. With this method the sum of all error types over all cases will equal 127, and the corresponding percentages can be calculated.

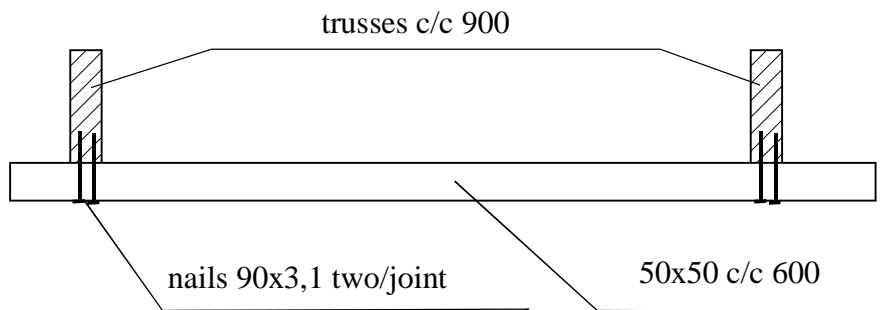

Figure 11. Support connection for ceiling in supermarket.

The results from the classifications of errors leading to failure are presented in Table 9. The first column shows the distribution of the nine error categories for all the 127 failure cases expressed as percentages. It can be seen that the most common cause of failure is related to design. Forty-one percent of the investigated failures are caused by poor design or lack of strength design. Other important failure causes are poor principles during erection (14.1%), on-site alterations (12.5%) and insufficient or lacking design with respect to environmental actions (11.4%). In total, about half of the failures are caused by the designer (deficiencies in design for strength and/or environmental actions). About one fourth of the failures are caused by the personnel working at the building site (on-site alterations, poor principles during erection). This means that wood quality, production methods and principles only cause a small part (together about 11%) of the failures. The problem is therefore not the wood material, but engineers and workers in the building process. This picture is similar to that found from other failure investigations for other types of structures (mostly steel and concrete), where human errors were found to be the dominating cause behind failure events. This is shown in Table 10, where the percentages of main failure causes from the present study are compared with corresponding data for steel and concrete structures found in references [10] and [2] respectively. For timber structures an additional element may be that many

building professionals are less skilled in design of more advanced wood structures. However, whether this is true or not, can not be deduced from the present investigation.

The collection of failure cases originates from four main sources:

- LTH (Division of Structural Engineering, Lund University, Sweden) with cases mainly taken from available literature sources.
- VTT (Technical Research Centre, Finland) with cases taken from failure investigations performed by VTT and the Finnish Accidents Investigations Board.
- SP (Swedish National Testing and Research Institute) with cases taken from failure investigations performed by SP itself.
- AE (Consultant Limträteknik, Falun, Sweden, Arne Emilsson) with cases taken from own investigations.

Table 9. Distribution of errors causing failure in the present study.

		% of failure cases					Gross number of identified causes without weights (in % of failures)
Failure category		All	LTH	VTT	SP	AE	All
1	Wood material performance	1.5	1.3	3.3	0.0	0.0	3.9
2	Manufacturing errors in factory	5.4	3.0	6.0	16.7	0.0	7.9
3	Poor manufacturing principles	4.2	0.6	5.0	18.9	0.0	5.5
4	On-site alterations	12.5	9.9	26.3	7.2	0.0	19.7
5	Design (mechanical loading)	41.5	44.2	38.7	30.6	50.0	54.3
6	Design (environmental loading)	11.4	11.9	12.7	12.2	4.2	16.5
7	Poor principles during erection	14.1	20.9	3.3	7.8	12.5	19.7
8	Overload	4.4	4.8	4.7	5.6	0.0	7.1
9	Other / unknown	5.1	3.4	0.0	1.1	33.3	7.1
Number of cases		127	67	30	18	12	

Table 10: Failure causes (in % of cases) for different building materials. Data from own survey, presented in chapters 3 and 4, as well as from the literature.

Failure cause	Timber [survey]	Steel [10]	Concrete [2]
Design	53	35	40
Building process	27	25	40
Maintenance / reuse		35	
Material	11		
Other	9	5	20

The material from each of these four sources may be different since the sub-samples are different and the analysis of the cases and the summary was made by different persons. Therefore, the distribution of failure causes for these sub samples are also presented in Table 9.

It can be seen that the causes of failure are to some extent correlated to the origin of the sub-samples. For example, the study carried out by SP contained an above-average share of manufacturing errors in factory and poor manufacturing principles. This is probably caused by the fact that SP has a special expertise in wood properties, wood quality and quality control. Consequently, it is more probable that SP gets more involved with failure cases where it is suspected that the failure has been caused by deficiencies in wood product quality. For all types of evaluation of failure events, it is also more probable that the investigator finds errors related to factors where his/her own expertise is best.

The last column in Table 9 shows the distribution of failures, if each identified type of error is counted with weight one, in contrary to the values in the other columns. Also these figures are given in percentages of the 127 failure cases, which means that the percentages added together become 142 %. With this alternative presentation the distribution pattern is very similar to that in column 1 and errors in strength design is still the most important cause of failure.

A few of the 127 failure cases can be seen as typical failures representing a number of similar buildings which failed in the same way and for the same reasons. Such cases have been included as one case in the data base in order not to bias the sample. One example is case 72 shown in Figure 11. This case represents at least 10 similar collapses in Finland. The same applies to case 101, which describes failures in old glulam beams manufactured in the 1960ies with a cold setting acid-curing adhesive, which had insufficient durability and is sensitive to moisture. The case was classified as type 3, "Poor manufacturing principles". Case 101 represents at least 20 similar buildings in Sweden, which all were identified shortly after the first failure cases were detected. Other "type" cases are nos. 74, 85, 92, 93 and 114, representing several other building

projects with similar failures. If all the parallel cases are included in the study the total amount of failure cases would amount to 179. Figure 12 shows the distribution of error types if all 179 cases are included in the data base. The figure also shows the corresponding distribution for the original 127 base cases. It is seen that the general picture of error types does not change, except for the category “Poor manufacturing principles”. The latter is explained by the fact that case 101 represents 20 similar events.

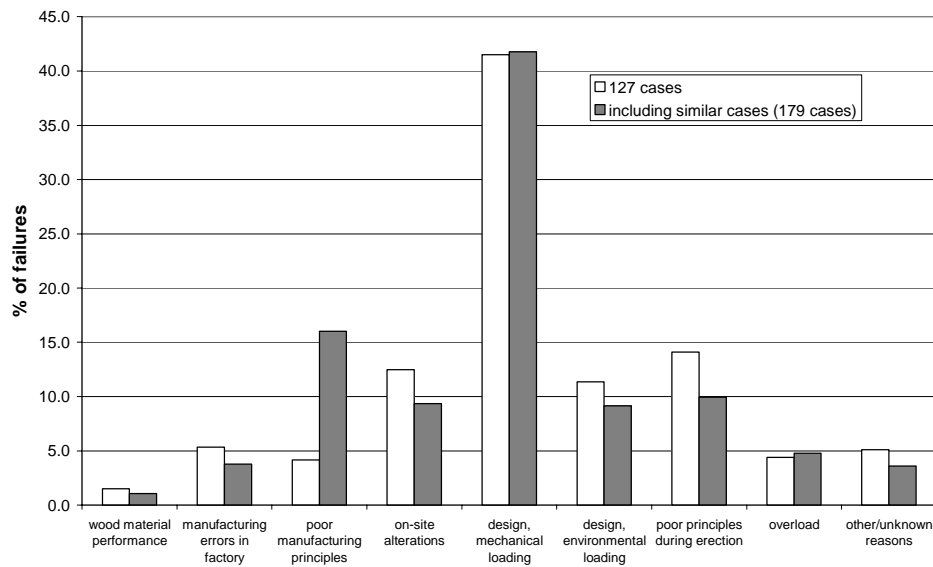

Figure 12. Distribution of error types for the cases in the data base with or without including parallel cases.

The study also showed that some failure causes are more common in certain countries. For example, overloading (of snow) seems to be overrepresented in Norway, whereas disregard of design for environmental actions is mostly found in the German cases, see Figure 13. Manufacturing errors in factory and poor manufacturing principles are most common in the cases from Sweden, but this is probably caused by the fact that SP has an expertise in this field. On-site alterations are most common in Finnish cases and poor principles during erection is frequent in the cases from United States.

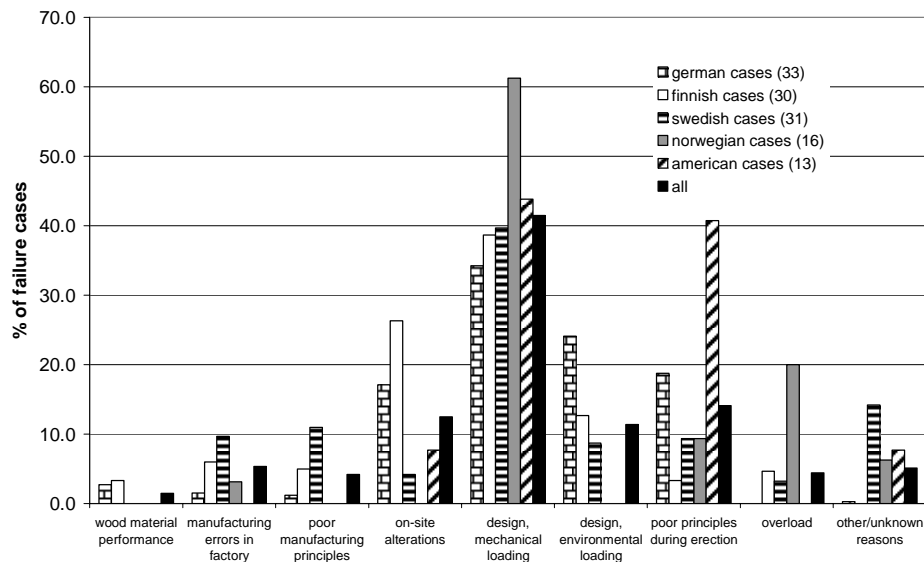

Figure 13. Failure causes depending on country.

4.2 Type of building and span of primary structure

This study comprised mostly buildings with large span structures, see Table 11 and Figure 14. Most of the buildings in the data base could be classified as having large span (>10 m) or small span (<10 m). Eighty-four percent of the cases where the span could be estimated, had a span of at least 10 m. A look on the span for those of the structures where more exact information about the span was available, shows that a large part of the failed structures had spans below 25 m, see Figure 14. This may be caused by the fact that a span of 10 to 25 m is not regarded as special and is quite common, thus no special attention is paid to design and execution. It could be hypothesised that every-day engineers accept projects of this type without being specialized in long-span structures or timber structures. For buildings with larger spans, it may be more common with independent control of the design or experts in the field doing the design. However, it should be kept in mind that the building stock contains much more small- and medium-scale structures than large-scale structures, which should result in fewer failures for long-span structures. There are no big differences in failure causes for small-scale and large-scale structures. On-site alterations seem to be more common in small-scale structures (22% of failures, compared to 11% in large-scale structures), whereas the problem of disregard of drying and related shrinkage is a more common problem in large-scale (and large-dimension) structures (12 % of failures, compared to 7 % in small-scale structures). However, errors and flaws in strength design are the most frequent causes of failure independent of span.

Most of the failures collected in this study occurred in public buildings (schools, sports halls, shops etc.), see Table 12. It is probable, however, that a collapse of a public building is more often reported and investigated than a private building.

Table 11. Spans in the buildings where failure occurred.

Span in failed buildings	Percentage of cases
Small span (< 10 m)	16
Large span (> 10 m)	84

Table 12. Types of buildings.

Type of building	Percentage of cases
Public (sports halls, schools, shops, etc.)	51
Industrial	23
Agricultural	7
Dwellings / apartments	8
Other / unknown	11

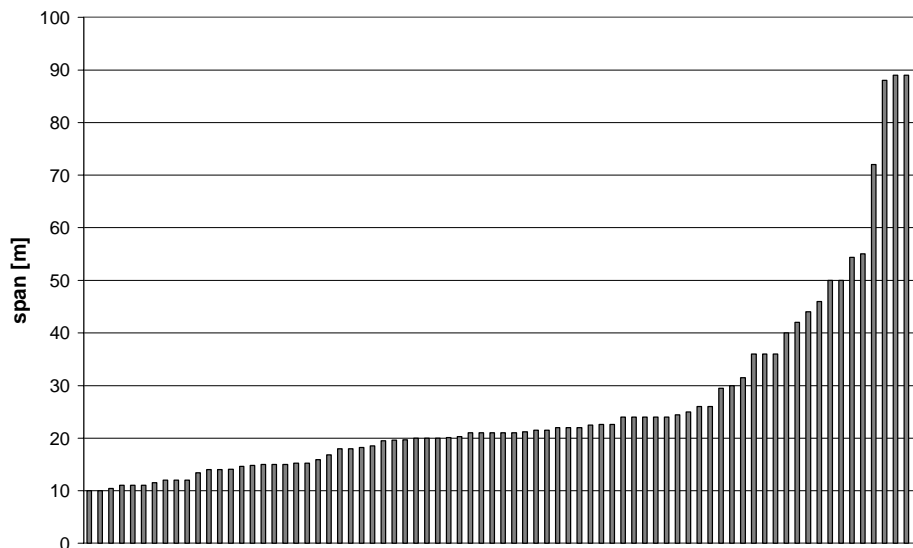

Figure 14. Span of failed structures (only spans above 10 m, 76 cases with known span).

4.3 Type of structural element involved in the failure

The types of structural element or joint involved in the failures are presented in Table 13. In many cases more than one type of element is involved in a single case. Therefore the sum of percentages in Table 13 is significantly larger than 100. Beams, trusses and bracing are the most frequent structural elements used in roof structures and also most frequent in the failure cases studied. Especially in the case of failure of trusses, almost all failures are caused by insufficient or absent bracing and poor principles during erection. Beams, especially curved beams and double-tapered beams with loads generating tension stresses perpendicular to the grain but also to a large extent straight beams, are dominant in the list of failures.

Joints were involved in the failure event in 23 % of all cases. Table 14 shows which type of joints were used in the cases where joints contributed to failure. Dowel-type joints are dominant, both in terms of their use in structures and among the failure cases.

Table 13. Type of structural element that failed.

Type of structural element	Percentage of cases
Beam	47
Truss	34
Bracing	29
Joint	23
Arch	8
Column	4
Frame	2

Table 14. Type of joint that failed.

Type of joint	Percentage of cases
Dowel-type	57
Punched metal plate	10
Glued	7
other	27

4.4 Failure modes involved in the investigated cases

In table 15 the distribution of failure modes identified in the investigated cases are presented. It can be seen that instability is a very dominant failure mode. This means that the collapse/failure was caused by insufficient/absent bracing, which led to buckling, or material failure. Bending failures and tension perpendicular to grain failures are also common.

Table 15. Failure modes.

Failure mode	Percentage of cases
Instability	30
Bending failure	15
Tension failure perpendicular to grain	11
Shear failure	9
Drying cracks	9
Excessive deflection	7
Tension failure	5
Corrosion of fasteners / decay	4
Withdrawal of fasteners	3
Compression	2
Other / unknown	21

4.5 Age of the structure at the time of failure

There is a correlation between failure mode and the age of the structure at the time of failure. About 19 % of the failure cases compiled in this study occurred during erection, about a third (34 %) during the first three years after completion and the rest later on, see Table 16 and Figure 15. Very remarkable is that about 21 % of the structures failed during the first year after completion. The average age at failure is 7 years. Some failures occurred after 30 to 40 years, but long-term behaviour such as duration of load behaviour, decay and corrosion can be held responsible for very few of the failures in this investigation. Such cases are probably more frequent but have not been included among the cases in this investigation.

Table 16. Time of failure (age known for 87 cases, i.e. 69 % of all cases).

Time of failure	Percentage of cases
During construction	18.6
During the first 3 years	33.7
After 3 years	47.7

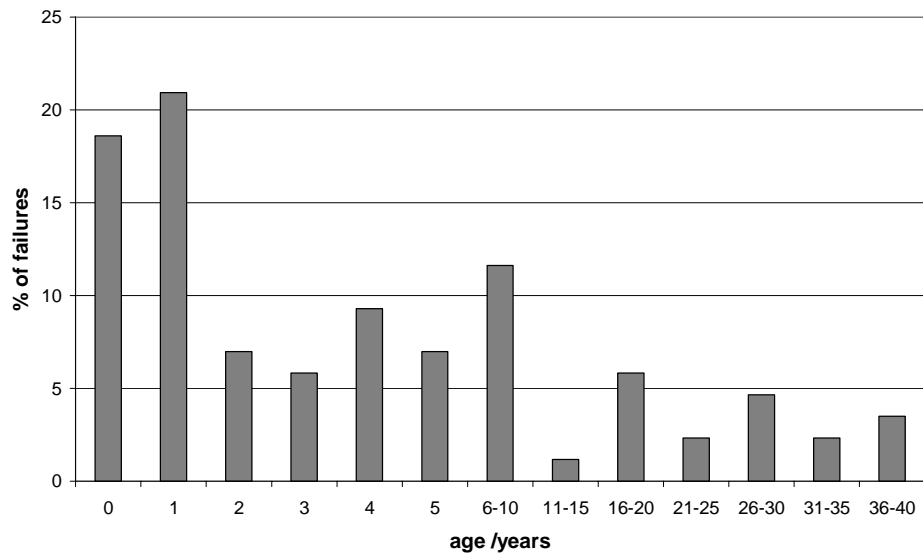

Figure 15. Age of the failed structures.

5. How can we learn from previous failures?

5.1 General

The majority of the failures compiled in the present study could have been avoided if available knowledge had been utilised in a correct way. About half of the failures are caused by errors in design or lack of design. One quarter of the failures was due to errors made on the building site. The study more or less confirms the conclusion made by Kaminetsky [6] that for structures of all types of materials, almost all failures occur due to human error. According to Kaminetsky, human errors can in turn be related to one or several of the following categories

1. Errors due to ignorance: Humans responsible for various tasks in the building process have inadequate training in relation to the tasks they have to fulfil. This can be improved by education and training.

2. Errors due to carelessness and negligence: The performance of humans in the building process is non-professional and they do not perform their tasks seriously enough. This may be improved by independent control measures.

3. Errors by “intent”: Responsible personnel consciously decide to take short-cuts and risks in order to save money and/or time in the building project.

It should be noted that failures due to human errors can not be counteracted by increasing safety factors or safety levels in structural codes. As was also found by e.g. Walker [26], see Table 5, almost no failures were caused by unfavourable combinations of random events. Thus, there is no evidence from the present investigation that the safety level for timber in structural codes is inadequate.

It is more or less impossible to eliminate the risk of human errors completely but their frequency can be reduced by improving building process management, where an important element is to assign or commission personnel with adequate experience and education as well as with the right attitude to the tasks at hand. This is however difficult to achieve in many building projects, since the client which should have the incentive for this often lacks the professional competence. This is a general problem in the building sector.

On a generic level only the first category of human error, lack of knowledge, can be reduced by improved training and education. The second and the third types which have to do with human attitudes are more difficult to take measures against. One way is to implement more efficient Quality Assurance (QA) systems in the building process. Such systems may be developed with special focus on design and construction of timber structures. The present report can hopefully be used as a basis for this.

Training, education and control measures should be especially focussed on those technical aspects found to be the most common causes of failures. Training of engineers and control in the design phase should have high priority, since the present investigation shows that most errors are made in this phase. Some of the issues which should be emphasised are

1. Bracing to avoid instability problems both in the finished structure and during construction.
2. Situations with risk for perpendicular to grain failure
3. Consideration of moisture effects
4. Design of joints

It is difficult to understand why the first one, relating to bracing, should be a problem at all. Engineers should have sufficient knowledge about the basic behaviour of load bearing structures, to be able to estimate the risk for lateral stability. This issue is not specific for timber structures.

The remaining issues, are more related to the use of wood material. Several of the design issues related to perpendicular to grain failure, moisture effects and the design of joints, are not standard knowledge and require special skills to handle.

5.2 Bracing

According to Table 15 the most common failure mode among the investigated cases is instability, often caused by insufficient bracing. Mistakes are made with respect to temporary bracing during the construction phase, which may lead to instability collapse and accidents at the building site. A typical example is case no. 47, where the roof trusses for a retail sales building collapsed during construction 1977 [33], see also Figure 16. The collapse was caused by top chord buckling and truss rollover. The trusses only carried 7 % of their total design load at the time of the collapse. In the finished building the truss system was intended to be laterally braced by bridging and plywood shear panels. None of this bracing had been installed when the failure occurred. To save crane time, all trusses were installed first and the bracing was planned to be added later.

This type of failure is very typical and can be avoided by planning of the erection sequences to minimise the risks and by giving clear instructions to the construction workers at the site on how to provide temporary bracing. Generally, more careful work preparation is needed at the building site. For more complex structures, the designer should be responsible for giving instructions about appropriate methods of bracing also in the construction phase.



Figure 16. Collapse of timber truss roof during construction. Source: Ref. [33].

Instability failure due to insufficient bracing is also quite frequent after the building is completed. A typical example is case 114, which is a timber truss roof with span of more than 20 m, which was built with insufficient lateral bracing of the top chord. This led to lateral buckling of the top chord as shown in Figure 17, with large lateral deformations. The tiling battens connecting the trusses with each other fell down between the trusses in several positions, which worsened the situation. A number of similar cases have occurred in Sweden, where the current structural code does not have any quantitative guidelines for design of lateral bracing. However, any engineer responsible for a structure of this type should be competent enough to realise that lateral bracing is necessary for the top chord of slender trusses.

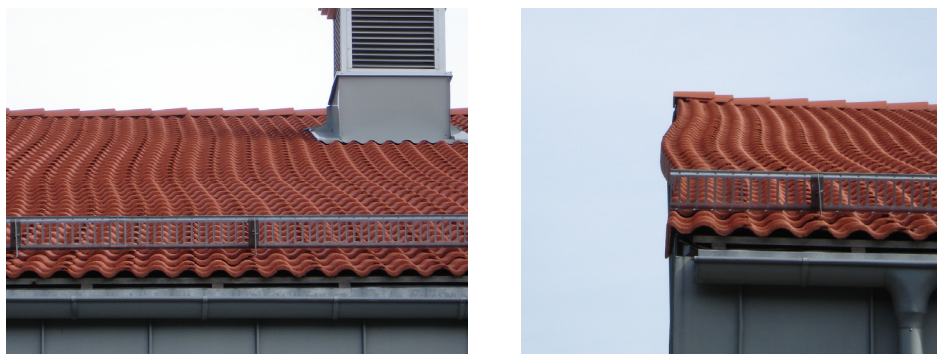

Figure 17. Deformations in roof due to lateral buckling of top chord of roof trusses.

These cases show that it is important to increase the awareness among engineers about the necessity of bracing against instability failure. This can be done by practical guidelines showing how to design for sufficient bracing of compression members and systems with such members. Relevant requirements for load-bearing capacity and stiffness of the structures used for bracing should be included in codes where such rules are missing, as in the Swedish structural code. A basis for this can be found in Eurocode 5.

5.3 Tensile stresses perpendicular to grain

A problem which is typical for timber structures is the risk for tension failure due to the low strength of wood in the perpendicular to grain direction. Notches and holes in wood members create such problems, as well as curved beams, pitched beams and beams with fibre direction at an angle to the beam edge. Perpendicular to grain failure is also a problem in joints where forces often act at an angle with the member direction.

Figure 18 shows cracking patterns from two cases, *100* and *103*, with inappropriate design of holes and notches respectively, which led to perpendicular to grain failure.

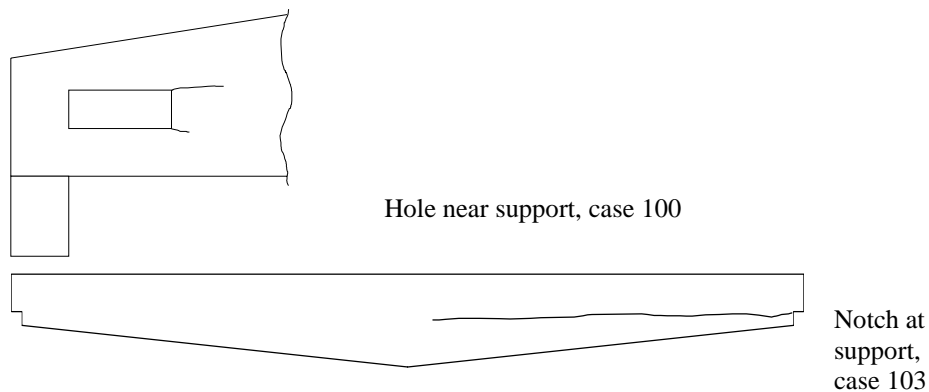

Figure 18. Schematic illustrations of perpendicular to grain failures in connection with holes and notches in large glulam beams.

Another example of perpendicular to grain failure is case 6, with straight glulam roof beams with a depth of 1.32 m and a width of 145 mm in the upper part and 120 mm in the lower part of the section, see figure 19. At the gable ends of the building, the roof was built on a lower level and supported on the bottom part of the main beams as shown in Figure 19. About one year after the building was completed, the lowered part of the roof collapsed at one of the gable ends. The loads from the lowered roof gave rise to

stresses perpendicular to grain in the vertical direction of the main beam. Eccentricities are also introduced which further increased these stresses. The main glulam beam was also notched near the support, so that only the upper 750 mm of the beam is placed on the support. This introduces additional tension stress perpendicular to the grain. The sum of the above described tension stresses could have led to failure when the beam is loaded with the maximum design load. However, no snow load was present at the time failure and the investigation concluded that additional factors were screws without predrilled holes positioned in the failure zone weakening the structure as well as extra loads from internal installations of sports equipment not considered in the original design.

Risks related to tensile stresses perpendicular to grain have to be carefully considered in design of timber structures. The problem is rather complex, but design tools are in most cases available even if they have been introduced during later years. Thus, some old buildings might have been designed e.g. for notches and holes with methods which later have been found to overestimate the strength.

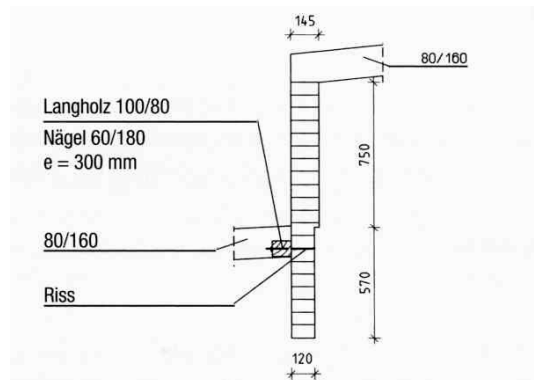

Figure 19. Section through glulam beam where failure was initiated, case 6.
Source: Ref. [7].

But what is more important is that many structural engineers forget about this problem as they are used to work with isotropic materials. A possible measure is to improve the training of structural engineers about problems directly connected to timber, such as consequences of strength anisotropy and shrinkage properties, and how to cope with that in design. For more advanced timber structures, special checking of the potential risk for perpendicular to grain failure should be included in design control procedures. Since moisture induced stresses often contribute to this type of problem it is natural to do this checking in connection with control plans for moisture effects.

5.4 Moisture effects

Both indoor and outdoor structures are exposed to an environment with changing relative humidity, and the moisture content in wood structures will normally change during their use. The most severe effects often take place when the building is new. It is quite common that wood with higher moisture content is built in and then dried after the building is heated. The change in moisture content in wood generates shrinkage/swelling strains, which are most significant in the perpendicular to the grain direction. However, moisture induced strains need sometimes to be considered also in the grain direction. If moisture movements are restrained, which often is the case, moisture induced stresses will develop. Stresses in the perpendicular to grain direction will often interact with tensile stresses from external loads leading to cracking and/or failure.

An example is case 4, where the structure consists of a pitched cambered glulam roof beam of 21 m span, see Figure 20. In the cambered part near the ridge, vertical glued-in rods were installed with the intention to take up parts of the tension stresses perpendicular to the grain occurring in this zone. The beams are located in a heated industrial building. Approximately 4 years after inauguration, deep cracks were detected in the cambered part of all 28 beams of the structure. It was concluded from the investigation that in this zone, free shrinkage was inhibited by the glued-in rods, resulting in 3-4 mm wide cracks at mid height of the beam. It was estimated that the shrinkage corresponded to drying from 11.5%, when the beams were installed, to 7.5-8% moisture content in the heated building during winter time.

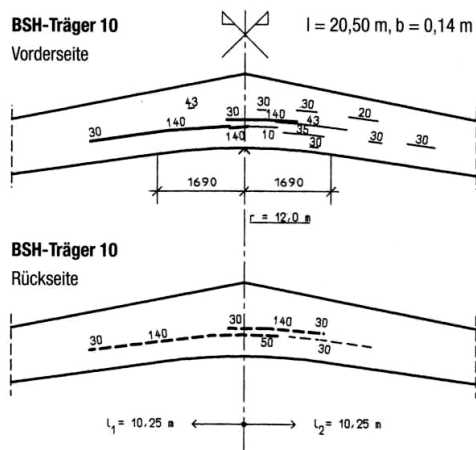

Figure 20. Cracks in pitched cambered roof beams due to restrained shrinkage. Views of both sides of a beam. Source: Ref. [7].

Moisture action must always be specially considered when dealing with wood. Special checks should be made to evaluate the effects of unavoidable moisture movements in the structure. Details where these movements might be restrained should be identified, and measures taken to minimise the risk of adverse stresses. In design of detailing in timber structures, effects associated with moisture strains should be considered. In particular, mechanical joints in timber structures should be evaluated from this point of view. Moisture effects should have high priority as an issue in education of timber engineering as well as in the design of control systems.

5.5 Joints

The most common method to connect timber elements today is by mechanical dowel type joints. Among the failure cases where joints are involved this is also the dominating type, see Table 7. The design of joints in timber structures is a difficult problem. The stress transfer in dowel type joints is very complex and cannot be described in detail in normal design situations. An additional complication is that wood is anisotropic and the risk of creating stresses perpendicular to grain is hard to evaluate. Eccentricities may develop in the joint area leading to much higher stresses in the wood than those found from the global analysis of the structure. In the joint region the dowels may also reduce the wood cross section in a significant way.

A well known example is the spectacular collapse of two long span roof trusses in the so called Ballerup arena in Denmark in January 2003. This is described in case 41, see also Figure 2. The primary roof structure is a fish-shaped truss with double upper and lower rafters and verticals (placed at 6.4 m centrals), but no diagonals, see Figure 21. The trusses span 72 m and are supported by concrete columns. When the failure occurred there was no snow on the roof and the actual load was only a fraction of the design load on the roof. A very detailed investigation after the failure revealed that multiple design errors had been made mainly related to the heel joint, which was designed with slotted-in steel plates and steel dowels, see references [15] and [34]. Another design error was that the tensile strength of the timber had been overestimated by about 50 % compared to the codified design values. The investigation concluded that the failure started as tension failure in the heel joint, see Figure 21.

The following errors were identified in design and strength verification of the joint:

1. The nominal cross-section was used in the calculations. However, at the heel joint, the cross-sections are reduced to make it possible to connect the upper and the lower rafters (inclined sawing). By this, the cross-sectional area was overestimated by 25 %.
2. The cross-section was not reduced (net cross-section) for bolt holes and slotted-in steel plates. This led to an overestimation of the cross-sectional area in the lower rafter by about 30 %.

3. Due to the inclined sawing of the members meeting in the heel joint, the normal force (centric at midspan) had an eccentricity of about 50 mm, resulting in an eccentricity moment, which was not considered in the design calculations.
4. The number of dowels and slotted-in steel plates gives a stiff joint, resulting in an additional moment, which was not considered in the design.
5. The design of the dowel joint was incorrect, using uniform load distribution across all dowels. This results in an overestimation of the capacity of dowels by 50 to 100 %.
6. Inclined sawing results in an angle between fibre direction and the beam edge, reducing tension and bending moment capacity.

A close study of this case can actually be used as a check list for design of joints in large scale timber structures.

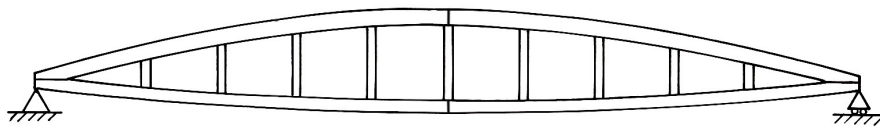

Fish shaped truss



Roof before failure



Failed heel joint

Figure 21. Roof structure at Ballerup arena, case 41.

Complex joints in timber structures also require careful and well controlled execution in manufacturing and construction. This is exemplified by case no. 68, where the roof collapsed over an area of about 2500 m² two weeks after the opening of an exhibition

hall in Finland. The main structure of the roof consisted of timber roof trusses with 55 m span and with connections designed with slotted-in steel plates and steel dowels.

The investigation following the collapse concluded that the main cause of failure was errors in manufacturing of the joints. For instance, in one of the joints of the truss which first failed, only seven dowels were installed correctly, while the number of dowels according to the design drawings should be 33, see Figure 3. This was due to shortcomings in the manufacturing procedure of the joints. The failure of the first truss also led to progressive type collapse of the roof structure. The reason for this was identified as insufficient capacity of the joints with respect to block shear failure. The strength design of the joint had been done on the basis of an earlier draft version of Eurocode 5 used as guideline, with inadequate design rules for this failure mode. However, this had been corrected in a more recent draft of the same code, which actually had been published before the design was made.

The above examples show that joints in timber structures must be treated with great care both in design and execution. In order for timber structures to be competitive there is need for development of robust joint solutions with well documented performance enabling rational and simple erection and manufacturing procedures. Design of timber joints should be of priority in timber engineering research and education as well as in Quality Assurance procedures.

5.6 Other issues

A number of other structural issues were identified from the failure survey. A common type of mistakes is also wrong appreciation of loading conditions and/or real behaviour of the structure. Every engineer should be able to choose the right statical system and apply the necessary loads. However, these problems are not specific for the material timber.

About one fourth of the failures are caused on the building site, by on-site alterations and poor principles during erection. Here, the most important factors seem to be time, money and management skill. Increasing the competence of professionals in the building process is very important and could be done by continuing courses and seminars, by professional training and by assigning trained and certified personnel to perform certain tasks. In addition to this, external quality control seems to be a necessary measure to reduce the frequency of failures in the future. This means quality control by impartial and certified personnel of both design and execution. However, this study indicated that regarding wood material and wood products, the quality control seems to be of fair standard.

6. Summary and conclusions

In the present report an investigation of failures in buildings with timber as a primary structural material is presented. The concept of failure considered here is mainly related to the ultimate limit state and is defined as events which have or could have implied risk for human lives.

A total of 127 failure cases were included in the survey. The data material used in the project was collected partly from direct information on failure cases provided by project participants who had been assigned to investigate failures and partly from cases documented in literature. The case reports were analysed and causes behind the failure event were classified with respect to the following nine categories:

1. Wood material performance
2. Manufacturing errors in factory
3. Poor manufacturing principles
4. On site alterations
5. Poor design/lack of design with respect to mechanical loading
6. Poor design/lack of design with respect to environmental actions
7. Poor principles during erection
8. Overload in relation to building regulations
9. Other/unknown reasons

The most common cause of failure found in the investigated cases is poor design or lack of strength design (41%). Other important failure causes are poor principles during erection (14.1%), on-site alterations (12.5%) and insufficient or lacking design with respect to environmental actions (11.4%). In total, about half of the failures are related to design. About one fourth of the failures are caused at the building site (on-site alterations, poor principles during erection). This means that wood quality, production methods and principles only cause a small part (together about 11%) of the failures. The problem is therefore not the wood material, but engineers and workers in the building process. This picture is similar to that found from other failure investigations for other types of structures (mostly steel and concrete), where human errors were found to be the dominating cause behind failure events.

The types of structural element or joint involved in the failures were recorded. Beams, trusses and bracing are the most frequent structural elements used in roof structures and also most frequent in the failure cases studied. Especially in the case of failure of trusses, almost all failures are caused by insufficient or absent bracing and poor principles during

erection. Beams, especially curved beams and double-tapered beams with loads generating tension stresses perpendicular to the grain but also to a large extent straight beams, are dominant in the list of failures. Joints were involved in the failure event in 23 % of all cases. Dowel-type joints are dominant, both in terms of their use in structures and among the failure cases.

Among the studied cases instability is a very dominant failure mode. This means that the collapse/failure was caused by insufficient/absent bracing, which led to buckling or material failure. Bending failures and tension perpendicular to grain failures are also common.

The study more or less confirms the conclusion made by other researchers that for structures of all types of materials, the vast majority of failures occurs due to human error. Failures due to human errors can not be counteracted by increased safety factors or safety levels in structural codes. As also found in many other investigations almost no failures were caused by unfavourable combinations of random events. Thus, there is no evidence from the present investigation that the chosen safety level for timber in structural codes is inadequate.

It is more or less impossible to eliminate the risk of human errors completely but their frequency can be reduced by improving building process management, where an important element is to assign or commission personnel with adequate experience and education as well as with the right attitude to the tasks at hand. Training, education and control measures should be especially focussed on those technical aspects found to be the most common causes of failures. Some of the issues which should be emphasised are

- Bracing to avoid instability problems both in the finished structure and during construction.
- Situations with risk for perpendicular to grain failure
- Consideration of moisture effects
- Design of joints

An important task for future research in timber engineering should be to develop methods to design robust structural systems, which are less sensitive to failure of single elements in the system and where the consequences of unforeseen events such as human errors and accidental loading are reduced.

7. References

- [1] Matousek, M., Schneider J. Untersuchungen zur Struktur des Sicherheitsproblems bei Bauwerken. Inst. für Baustatik und Konstruktion, ETH, Zurich, 1976.
- [2] Brand, B., Glatz, G. Schäden an Tragwerken aus Stahlbeton. Schadenfreies Bauen, Band 14, 2nd Ed. Fraunhofer IRB Verlag, Stuttgart 2005.
- [3] Feld, J. Lessons from failures of concrete structures. ACI Monograph, No.1, Detroit 1964.
- [4] McKaig T.H. Building failures. Case studies in Construction and Design. McGraw-Hill, New York, 1962
- [5] Feld J. Construction Failure. John Wiley & Sons, New York, 1968.
- [6] Kaminetzsky D. Design and Construction Failures – lessons from forensic investigations. McGraw-Hill, New York, 1991.
- [7] Dröge, G., Dröge, T. Schäden an Holztragwerken. Schadenfreies Bauen, Band 28, Fraunhofer IRB Verlag, Stuttgart 2003.
- [8] Mönck, W., Erler, K. Schäden an Holzkonstruktionen. Huss-Medien GmbH, Verlag Bauwesen, 4th Ed., Berlin 2004.
- [9] Colling F. Lernen aus Schäden in Holzbau - Ursachen, Vermeidung, Beispiele. Deutsche Gesellschaft für Holzforschung. Fraunhofer IRB Verlag, Stuttgart 2000.
- [10] Oehme P., Vogt W. Schäden an Tragwerken aus Stahl. Schadenfreies Bauen, Band 30. Fraunhofer IRB Verlag, Stuttgart 2003.
- [11] Munch-Andersson, J., Buhelt, M. Stormskader på bygninger. Undersøgelse av skader ved stormen 3. december 1999. By og Byg resultater 001. Statens Byggeforskningsinstitut, Hørsholm, 2000.
- [12] Scheer, J. Versagen von Bauwerken. Ernst & Sohn, 2001
- [13] Gerhardt H.J. Windschäden. Fraunhofer IRB Verlag, Stuttgart 1999. Ed. 2005.
- [14] Thorup, P.M., Larsen H.J. Skønserklæring Ballerup Superarena. March 2003.
- [15] Hansson M., Larsen H.J. Recent failures in glulam structures and their causes, Engineering Failure Analysis, Elsevier, 12(2005), pp 808-818.
- [16] Finnish Accident Investigation Board. Fair center roof collapsing in Jyväskylä on Feb. 1, 2003. Report B2/2003 Y; 2004. Available from: www.onnettomuustutkinta.fi (in Finnish).

- [17] Ellingwood, B. Design and construction error effects on structural reliability. ASCE, J. of Structural Engineering, 13, no. 2, 1987, pp. 409-422.
- [18] Yamamoto, M., Ang, A.H. Reliability Analysis of Braced Excavation. Structural Research Series No. 497, Dep. of Civ. Eng., Univ. of Illinois, Urbana, 1982.
- [19] Grunau, E.B. Aus Bauschaden lernen. Verlagsgesellschaft Rudolf Müller, Köln, 1979. Quoted from reference [25].
- [20] Reygaertz I., et al. 1200 problèmes, erreurs de conception, défauts de construction, dégâts. C.S.T.C.-revue, No. 3, 1976. Quoted from reference [25].
- [21] Melchers, R.E., Baker, M.J., Moses, F. Evaluation of experience. Proceedings, IABSE Workshop on Quality Assurance within the Building Process, Rigi, Switzerland, 1983, pp. 9-30.
- [22] Fraczek, J. ACI survey of concrete structure errors. Concrete International, Vol. 2, No. 12, Dec. 1979, pp. 14-20.
- [23] Allen, D.E. Errors in concrete structures, Canadian Journal of Civil Engineering, Vol. 6, No. 3, Sept. 1979, pp. 465-467.
- [24] Hadipriono, F.C. Analysis of events in recent structural failures. J. of Struct. Eng., ASCE, Vol. 111, No. 7, July 1985, pp. 1468-1481.
- [25] Hillemeier, B. Practical aspects of planning for quality. Proceedings, IABSE Workshop on Quality Assurance within the Building Process, Rigi, Switzerland, 1983, pp. 65-75.
- [26] Walker A.C. Study and analysis of the first 120 failure cases. Structural failure in buildings. The Institution of Structural Engineers, 1981.
- [27] Eldukair Z.A., Ayyub, B. M. Analysis of recent US structural and construction failures. ASCE, J. of Performance of Constructed Facilities, Vol. 5, No. 1, Feb. 1991, pp. 57-73.
- [28] Epaarachchi D.C., Stewart M.G. Human error and reliability of multi-storey reinforced concrete building construction. J. of Performance of Constructed Facilities, Vol. 18, No. 1, Feb. 2004, pp. 12-20.
- [29] Yates J.K., Lockley E.E. Documenting and analysing construction failures. ASCE, J. of Construction Engineering and Management, Vol. 128, No. 1, Jan/feb. 2002, pp. 8-17.
- [30] Collins M.P., Vecchio F.J., Selby R.G., Gupta, P.R. The failure of an offshore platform. Concrete International, Volume 19, No. 8, August 1997, pp. 28-35.
- [31] Wittfoth H. Triumph der Spannweiten. Beton-Verlag GmbH, Düsseldorf, 1972.

- [32] Klöppel K., Bilstein W. Berechnungsgrundlagen für Kastenträgerbrücken in Grossbritannien (Merrison Bericht). Stahlbau, Vol 43, No. 10, Berlin 1974, pp. 298-304.
- [33] Ratay R., Forensic Structural Engineering Handbook, McGraw-Hill, 2000.
- [34] Thorup, P.M., Larsen, H.J., Skønserklæring, Ballerup Superarena, Syn & Skøn – Jour. Nr. A 5102 ved Voldgiftsnævnet for Bygge- og Anlægsvirksomhed, 4.3.2003. (In Danish).
- [35] Skaug, E., Skader på moderne trekonstruksjoner i Norden (Failures of modern timber structures in the Nordic countries), Masters Thesis 2004, Faculty of Engineering Science and Technology, Dep. of Structural Engineering, NTNU (In Norwegian).
- [36] Törmänen J., Leskelä M. Failures in timber structures (in Finnish: Kantavien puurakenteiden vaurioselvitys, tutkimusraportti RTL 0021). University of Oulu, 1996.

Annexe: Description of individual cases

Notations and abbreviations

Classification of failure causes

1. wood material performance
2. manufacturing errors in factory
3. poor manufacturing principles
4. on-site alterations
5. design, mechanical loading
6. design, environmental loading
7. poor principles during erection
8. overload
9. other / unknown reasons

Materials

- ST structural timber
GL glulam

Source

- LS literature study
VTT VTT
SP SP
AE Limträteknik AB, Falun, Arne Emilsson

Overview of all cases with rating

Case	Material	Rating of failure causes									Source	page
		1	2	3	4	5	6	7	8	9		
1	ST					1					LS	52
2	ST				0.2		0.8				LS	53
3	GL						1				LS	54
4	GL						0.5	0.5			LS	55
5	GL	0.1				0.2	0.4	0.3			LS	57
6	GL					0.8		0.2			LS	59
7	GL					0.8	0.2				LS	61
8	GL					1					LS	63
9	GL					0.5	0.5				LS	64
10	GL					1					LS	65
11	ST	0.1				0.4		0.5			LS	66
12	GL					0.5		0.5			LS	68
13	Plywood							1			LS	69
14	GL						1				LS	71
15	ST							1			LS	73
16	Plywood, ST							1			LS	74
17	ST						1				LS	75
18	ST					0.7		0.3			LS	76
19	GL							1			LS	77
20	ST					0.7		0.3			LS	79
21	ST							1			LS	80
22	ST					1					LS	81
23	ST									1	LS	82
24	GL					1					LS	83
25	GL								1		LS	85
26	GL	0.2	0.3		0.5						LS	86
27	GL		0.5						0.5		LS	87
28	GL					1					LS	88
29	GL								1		LS	89
30	GL					1					LS	90
31	ST					1					LS	91
32	GL					0.5			0.5		LS	92
33	ST							1			LS	94
34	GL					1					LS	95
35	GL					1					LS	97
36	GL + ST					1					LS	99
37	ST					0.8			0.2		LS	101

Case	Material	Rating of failure causes									Source	page
		1	2	3	4	5	6	7	8	9		
38	ST									1	LS	102
39	ST					1					LS	103
40	ST					0.5		0.5			LS	104
41	GL					1					LS	105
42	GL					0.8				0.2	LS	107
43	GL				0.4	0.6					LS	108
44	ST					0.1		0.9			LS	109
45	Box girders		0.2	0.4		0.3				0.1	LS	110
46	GL					1					LS	112
47	ST							1			LS	113
48	ST					1					LS	114
49	GL					1					LS	115
50	ST					1					LS	116
51	GL		1								LS	117
52	ST	0.5			0.5						LS	118
53	GL				1						LS	119
54	ST							1			LS	120
55	ST					1					LS	121
56	ST				1						LS	122
57	ST				0.5	0.5					LS	124
58	ST				0.3	0.4	0.3				LS	125
59	GL						1				LS	126
60	GL						1				LS	127
61	ST				1						LS	128
62	ST							1			LS	129
63	ST				1						LS	130
64	ST							1			LS	131
65	ST				0.25	0.5	0.25				LS	132
66	ST					1					LS	133
67	ST					1					LS	134
68	GL		0.8			0.2					VTT	136
69	GL						1				VTT	138
70	ST					1					VTT	140
71	GL					1					VTT	142
72	ST			0.5		0.5					VTT	144
73	GL							1			VTT	146
74	ST				0.5	0.5					VTT	148
75	ST				1						VTT	150
76	LVL					1					VTT	151
77	ST				0.5	0.5					VTT	153

Case	Material	Rating of failure causes									Source	page
		1	2	3	4	5	6	7	8	9		
78	ST				0.5	0.5					VTT	154
79	GL	1									VTT	155
80	ST				0.8	0.2					VTT	157
81	ST				0.8	0.2					VTT	158
82	ST				0.8	0.2					VTT	159
83	ST				0.8				0.2		VTT	160
84	ST					1					VTT	161
85	GL								1		VTT	162
86	ST					1					VTT	163
87	ST						0.8		0.2		VTT	164
88	ST				0.2	0.8					VTT	165
89	ST		1								VTT	166
90	ST					1					VTT	167
91	ST				0.5	0.5					VTT	168
92	GL						1				VTT	169
93	ST					1					VTT	170
94	GL						1				VTT	171
95	GL			1							VTT	173
96	ST				0.5	0.5					VTT	174
97	ST				1						VTT	175
98	GL				0.5	0.5					SP	176
99	GL		1								SP	177
100	GL		0.2			0.8					SP	179
101	GL			1							SP	181
102	GL								1		SP	182
103	GL			0.4		0.4		0.2			SP	183
104	GL							1			SP	185
105	GL						1				SP	187
106	GL					0.8	0.2				SP	189
107	GL					1					SP	191
108	GL		1								SP	192
109	GL						0.8	0.2			SP	193
110	GL		0.8				0.2				SP	195
111	GL					1					SP	196
112	GL			1							SP	198
113	Composite			1							SP	200
114	ST					1					SP	202
115	GL				0.8					0.2	SP	205
116	ST					1					AE	207
117	ST									1	AE	208
118	GL					1					AE	209

Case	Material	Rating of failure causes									Source	page
		1	2	3	4	5	6	7	8	9		
119	GL									1	AE	210
120	GL					1					AE	211
121	Plywood									1	AE	212
122	GL						0.5	0.5			AE	213
123	GL					1					AE	215
124	GL					1					AE	216
125	GL							1			AE	217
126	GL									1	AE	219
127	GL					1					AE	221

Case 1 – Continuous beams with internal hinges in industrial building

Description of Structure

The roof structure consists of continuous purlins of Gerber type with internal hinges. Centre distance between the purlins cross-section 80 mm x 140 mm is 1.2 m. They are supported by primary glulam girders every 5 m. Over a local area of 4.85m x 6.5 m on the otherwise flat roof a structure that is distinctly higher than the roof structure was present.

Description of failure

Approximately 4 years after inauguration, 3 purlins on the leeward side of the elevated roof collapsed on a sunny winter day. A large amount of snow was falling down into the hall, although no snow was present on the undamaged part of the roof. Investigations showed that the snow depth adjacent to the elevated roof must have been about 1.5 m in average.

Original investigation performed and conclusions

The purlins were designed for a distributed load consisting of permanent load and a snow load of 0.75 kN/m^2 . At the time of failure, a snow load of 1.8 kN/m^2 was present on the damaged part of the roof whereas the other spans of the continuous purlins were not loaded with snow at all. The high snow load causes stresses in the beams that exceed the bending strength. It is common knowledge that beams with internal hinges are sensitive to non-uniform loading. A continuous beam without hinges would probably have been able to withstand the stresses caused by the non-uniformly distributed snow load better.

This failure is caused by a combination of 2 design errors. The elevated part of the structure, surmounting the roof structure, leads to risk for snow drift, i.e. locally high snow load. Continuous beams with internal hinges are not appropriate in this case with non-equally distributed load. One could say that extreme loading is the cause of the failure, but with the present structure, this kind of loading should have been considered.

Additional conclusions and comments

Locally high snow load due to snow drift is usually considered as a special load case in structural codes. This was not considered in this case.

Source

Dröge G. & Dröge T.: Schäden an Holztragwerken, Schadenfreies Bauen, Band 28, Fraunhofer IRB Verlag, 2003, case 2.1-2

Case 2 – Truss in agricultural building (barn)

Description of Structure

The structure consists of a roof truss with span of 15 m over a barn (cattle), topped with metal sheathing. Below the truss, a suspended ceiling with thermal insulation and vapour barrier was present.

The truss is built up by structural timber, slotted-in steel plates and nails.

Description of failure

After 17 years of use, excessive deflections were observed in some parts of the structure.

Original investigation performed and conclusions

The investigation revealed corrosion of metal fasteners that connected the suspended ceiling with the truss, as well as in the slotted-in steel plates. The corrosion led to near collapse of some joints. The most serious corrosion was observed in the midspan, which led to large deflections. If serious corrosion also had happened near the supports, this might have caused a collapse of the whole roof. The building could not be renovated but had to be taken down.

Warm and moist air caused overpressure inside the barn, which caused the aggressive air to move into the attic through leakages in the vapour barrier. The thermal insulation was discontinuous at the lower chord of the truss, which led to thermal bridges and condensation, amplifying the corrosion.

In the original design, the joints were designed with plywood and nails. Due to the lower price, slotted-in steel plates were used in the final construction, without approval of the designer.

Source

Dröge G. & Dröge T.: Schäden an Holztragwerken, Schadenfreies Bauen, Band 28, Fraunhofer IRB Verlag, 2003, case 2.3-1

Case 3 – Glulam beams in sports hall

Description of Structure

The main glulam beams of the roof structure of a sports hall had a cross-section of 160 mm x 1400 mm. About 350 mm from the lower edge of the beams, a suspended ceiling was placed, separating the warmed-up sports hall from the roof structure (in contact with outdoor climate).

Description of failure

During the first heating period after inauguration, a large crack in lengthwise direction appeared in one of the glulam beams directly below the ceiling. The crack went through the whole width of the beam in some areas.

Original investigation performed and conclusions

The investigation revealed that the moisture content of the glulam beam was about 12 % MC in the part above the ceiling, whereas a value of 7% MC was found for the part of the beam that was exposed to the warmer climate in the hall, below the ceiling. After finished construction in November, the sports hall had been brought into use and warmed up with warm, dry air, while the climate outdoors was quite cold. This led to fast drying resulting in a large moisture difference between the upper edge and the lower edge of the beam, causing cracking to release the moisture induced stresses.

The beam was renovated by lifting up the lower part and filling the gap with synthetic resin.

Source

Dröge G. & Dröge T.: Schäden an Holztragwerken, Schadenfreies Bauen, Band 28, Fraunhofer IRB Verlag, 2003, case 2.4-1

Case 4 – Pitched cambered glulam beams

Description of Structure

The roof of a warmed-up industrial building is built with pitched cambered glulam beams with 21 m span, see Fig. 20 in Chapter 5. In the cambered part near the ridge, glued-in rods were installed to take up parts of the tension stresses perpendicular to the grain.

Description of failure

Approximately 4 years after inauguration, cracks were observed in the glue line of the cambered part of one beam. When investigating closer, it was found that all 28 beams of the structure had similar cracks.

Original investigation performed and conclusions

Surface cracks with small depth are found over more or less the whole beam length, whereas deep cracks, in some cases through the entire width, are found in the cambered part of the beam, where glued-in rods were used. At the time of inspection, an average moisture content of 8% was measured. Investigation of the structural design shows that the actual loads do not exceed the design loads. However, the glued-in rods are designed to take up only that part of the tension perpendicular to grain, which cannot be taken up by the glulam itself. The glulam can take up tension stresses perpendicular to the grain resulting from the permanent loads, however, to carry the total load (including snow load), the glued-in rods were utilized in design. During the 4 years of use, no large snow load was observed, meaning that the cracks must have some other reason.

The glulam beams were produced with an average moisture content of 11.5%. However, at the time of investigation, the moisture content was determined to be 8%. Furthermore, it is concluded that the moisture content might have been even lower than 8% during wintertime, caused by heating. The shallow cracks in the straight part of the beam indicate accelerated drying after inauguration. In the cambered part of the beam, free shrinkage was inhibited by the glued-in rods, resulting in one large crack (about 3-4 mm wide) at mid-depth of the beam. This crack might be caused by the shrinkage process when drying from 11.5% to about 7.5 to 8% MC. Due to these cracks, the glued-in rods have to take up the whole tension perpendicular to the grain, but they are only designed for 46% of the stresses resulting from total load. All beams had to be renovated with prestressed steel clamping.

This failure is caused by a combination of execution error (fast drying to equilibrium moisture content, too large moisture content difference, inhibited shrinkage) and design error (if cracks cannot be prevented, the glued-in rods should have been designed to take up the total load).

Source

Dröge G. & Dröge T.: Schäden an Holztragwerken, Schadenfreies Bauen, Band 28, Fraunhofer IRB Verlag, 2003, case 2.4-3

Case 5 – Cracks in glulam beams of a sports hall

Description of Structure

A sports hall and a side building are covered with a roof of continuous glulam beams. Cross sections are 150 mm x 1000 mm in the 18.2 m span of the sports hall and 150 mm x 750 mm in the 7.3 m span of the side building respectively. Thermal insulation is placed above the beams and the roof is flat. At the lower edge of the beams, a ceiling is installed. Air and water pipes are placed between the beams.

Description of failure

About 2 years after inauguration of the building, large deflections occurred in parts of the sports hall (span 18.2m) after a heavy thunderstorm with extreme rainfall. The structure had to be supported to prevent failure.

A large number of cracks occurred in the glulam beams in the large span, and sometimes also near the support in the small span (side building). One beam (number 6) was cracked along almost the whole length of the long span at mid depth.

Original investigation performed and conclusions

At the time of investigation, the maximum water depth on the roof was 11cm. The lowest point of the roof was situated 10.7cm below the nearest drainage pipe. The failure of beam 6 is due to a combination of several errors which, if occurring individually, had not led to failure.

Error 1: Inadequate consideration of climatic conditions.

The numerous cracks are caused by fast drying. During construction, the beams were exposed to humid climate with some excessive rainfalls for at least 43 days, increasing the beams' moisture content from about 11% MC to 20% MC. After finished construction, the sports hall was warmed up very fast, leading to cracking. Along the lower edge of beams 2 and 6, warm-water pipes were installed, causing fast drying of the lower edge, leading to a large crack in beam 6 that separates the upper from the lower part of the beam. Holes through which the pipes were led, were placed in the beams. The pipes were not insulated in the holes, which led to excessive and fast drying of the end grain, leading to cracking in all holes with pipes (no cracking for empty holes). It is assumed that the separating crack in beam 6 originated from a hole. Protection from rainfall and slow warm-up of the building could have prevented the damage.

Error 2: Worst load case was not investigated.

The glulam beams were designed for a uniform load consisting of dead load, snow load, gravel ballast on the roof, and installations such as pipes and lamps. It was assumed that all these loads are uniformly distributed along the beam length and along both spans

(sports hall and side building). Furthermore, it was assumed that the roof is absolutely flat. However, load-induced deformations led to ponding of rain water, which remained on the roof as water and ice for a long time (medium to long-term load). The water load occurs mainly in the large span, since the smaller span has a negative deflection. Furthermore, the installations (pipes, lamps etc) are concentrated in the large span instead of being uniformly distributed along both spans. This leads to higher loads in the large span, leading to higher stresses, which could have been taken up if the beam had been intact. However, the drying cracks described above lead to reduced shear capacity, finally resulting in a separating crack due to shear failure. The high loads are caused by a design error: The drainage system of absolutely flat roofs has to be placed at the lowest point of the roof when it is deflected due to loading.

Error 3: Some of the beams did not meet the specifications of the quality class used.

Large knots in the tension side of the beams may lead to reduced strength. Due to this quality error, restoration with a steel structure was necessary instead of a restoration by filling the cracks with glue.

The combination of these 3 errors (excessive drying leading to cracks, wrong distribution of loads and lower quality) led to failure. However, if only one of the errors had occurred, the structure would probably not have failed.

Source

Dröge G. & Dröge T.: Schäden an Holztragwerken, Schadenfreies Bauen, Band 28, Fraunhofer IRB Verlag, 2003, case 2.4-4

Case 6 – Collapse of glulam beam in a sports hall

Description of Structure

A sports hall (33.6m x 18m) is roofed in the central part by double-tapered glulam beams placed at 4.2 m centres. At the two gable ends of the building, the roof is on a lower level. Here, straight glulam beams with a depth of 1.32 m and a width of 145 mm in the upper part (h=750mm) and 120 mm in the lower part (h=570mm) carry the roof, see Figure 6-1. Structural timber 100 mm x 80 mm is nailed along the lower part of the glulam beam, to provide support for the lowered roof. The lowered roof is carried by structural timber (cross-section 80 mm x 160 mm). At the support, the glulam beam is notched, with a notch height equal to the lower part of the beam, i.e. 570 mm.

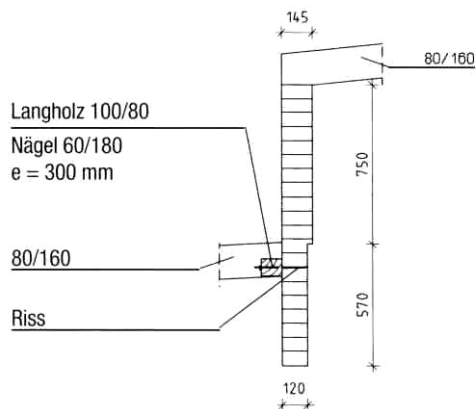

Figure 6-1: Glulam beam with support of lowered roof. Picture from Dröge G. & Dröge T.: *Schäden an Holztragwerken, Schadenfreies Bauen, Band 28*, Fraunhofer IRB Verlag, 2003.

Description of failure

About 1 year after inauguration, the lower part of the glulam beam and the lowered roof collapsed. On the other end of the building, the corresponding beam was cracked, but did not collapse. At the time of failure, no snow load was present on the roof, i.e. the structure was not loaded with full design load.

Original investigation performed and conclusions

The support of the lowered roof induced tension stress perpendicular to the grain in the glulam beam. Due to the eccentricity, additional tension stress was induced. Near the support of the beam, the glulam beam is notched, so that only the upper, wider part of

the beam is placed on the support. The notch introduces additional tension stress perpendicular to the grain into the beam. The sum of these tension stresses could lead to failure when the beam is loaded with the maximum design load. However, at the time of failure, no snow was present, i.e. the failure must have been caused by some other additional factor. The crack leading to failure begins near the support where climbing ropes were fastened with screws, then propagating along the line of the nails that fasten the structural timber, bearing the lowered roof. The investigation revealed that screws as well as nails were driven into the glulam without pre-drilling. This led to increased risk for cracking. Furthermore, the ropes are used for sports (climbing), introducing additional loads into the beam. The combination of non-predrilled screws and nails, high tension stress perpendicular to the grain and additional vertical loads from the ropes (not in the original design) led to the failure.

Source

Dröge G. & Dröge T.: Schäden an Holztragwerken, Schadenfreies Bauen, Band 28, Fraunhofer IRB Verlag, 2003, case 2.6.1-1

Case 7 – Bending failure in tapered beam in industrial building

Description of Structure

A 125 m wide industrial building is covered by continuous glulam beams with Gerber type hinges in every second span (span 22.6 m), see figure 7-1. Near the supports, the beam is tapered to increase the depth near the support. The roof is completely flat, leading to large water pools after rain. Glulam beams and purlins have been designed for uniform load comprised of dead load, extra load due to fixtures and fittings and snow load. The beams had been designed with full utilization both in the bays and at supports. As the support area is too small to transfer the support load with respect to compression perpendicular to the grain, standing boards were glued to both sides of the beam. The boards transfer the support load via their end grain to the concrete column.

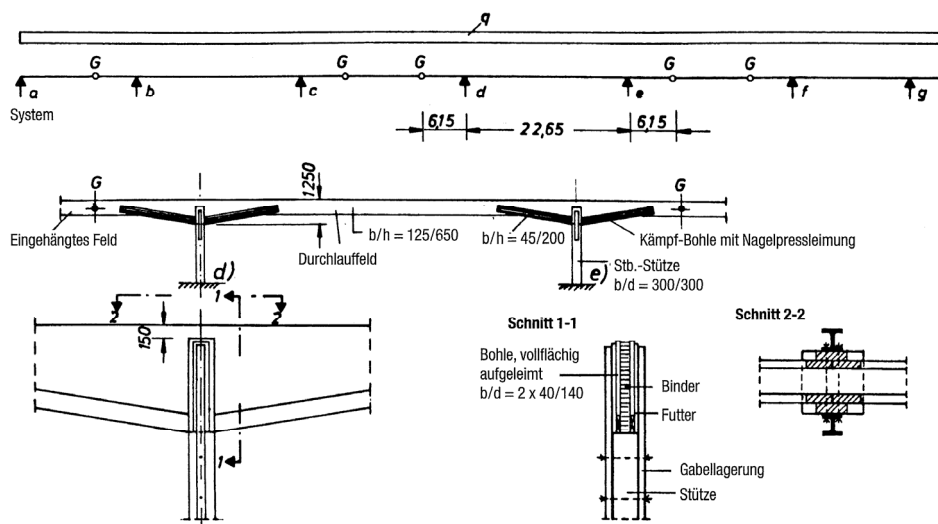

Figure 7-1. Top: Continuous glulam beams of Gerber type with hinges in every second span. Middle: Strengthening with boards, glued to lower edge of beams in the tapered area, carried out after first failure. Bottom: Detail at support before first failure. Picture from Dröge G. & Dröge T.: Schäden an Holztragwerken, Schadenfreies Bauen, Band 28, Fraunhofer IRB Verlag, 2003.

Description of failure

A short time after inauguration, bending failure occurred in one beam in the tapered zone directly after a heavy thunderstorm with high rainfall. The water load was approximately equal to the design snow load.

Original investigation performed and conclusions

The largest bending stresses occur when the beam is loaded with the design load along all its length. However, at the time of failure, the actual load was smaller than the design load. A theoretical investigation of the stress distribution in the tapered zone of the beam revealed excessive shear stresses at the lower edge of the beam, resulting in shear cracks. These cracks led to a reduction in cross section taking up bending stresses, finally leading to a bending failure.

The lower edges in the tapered parts were then strengthened with boards (Lamelle aus Kämpfstegplatten) that were glued to the sides of the beams, see figure 7-1. The cracks were filled with glue and the damaged beam was replaced.

After 6 more years, a failure occurred again after a heavy rainfall. This time the failure occurred at mid-span and is described in case 10. However, the tapered zones near the supports were also investigated. Large horizontal through cracks at mid-depth were found. These cracks had propagated about 2m in each direction from the supports. The investigation showed that the diagonally attached sideboards from the first restoration led to diagonal transfer of compressive force from the bay area towards the support. The compression forces in the diagonal sideboards are not in equilibrium with the support forces, leading to a suspension of the forces via the beam and the vertical boards at the support, causing large tension stresses that lead to cracking perpendicular to grain. In addition, cracking may have been caused by restraint of transverse shrinkage of the beam by the vertical boards. This time, the restoration focussed on decreasing the tension stresses perpendicular to the grain. The vertical boards were shortened to prevent them from transferring the support loads. Instead, the loads are transferred by compression perpendicular to the grain via a support detail made of steel. In addition, the cracks were filled with glue.

Additional conclusions and comments

The second failure is described in case 10.

Source

Dröge G. & Dröge T.: Schäden an Holztragwerken, Schadenfreies Bauen, Band 28, Fraunhofer IRB Verlag, 2003, case 2.6.1-2

Case 8 – Collapse of glulam beams in swimming hall

Description of Structure

The roof structure of a swimming hall consists of straight glulam beams which are connected with a bracing. On one end, the beams are supported by a concrete wall, on the other end by glulam columns. The joint between glulam beam and glulam column is carried out with slotted-in steel plates and dowels. In the column, the dowels are distributed over a large area, giving a stiff connection. In the beam, the joint is made as a hinge by placing the dowels close to each other, only using the lower edge of the steel plate.

Description of failure

After heavy snowfall, the whole roof structure collapsed.

Original investigation performed and conclusions

The snow load at the time of failure was equal to the design load; therefore excessive load was not the cause of failure. The investigation showed that the glulam beams had been weakened by holes that were not according to the design. This resulted in a deflection of the beam which also included a rotation of the support. In contrast to the design, the connection between beam and column behaved stiff, not hinged, resulting in failure of the connection. This triggered a series of events which ultimately led to collapse of the whole structure.

Many design errors in this structure were caused by the lack of communication between several engineers working with the whole structure, the joints, the drawings etc. There are some differences between the several designs, e.g. for the connection between column and beam. If a connection is designed to be hinged but is slightly stiff in reality, it has to be investigated whether deflections can cause a failure of the connection.

Source

Dröge G. & Dröge T.: Schäden an Holztragwerken, Schadenfreies Bauen, Band 28, Fraunhofer IRB Verlag, 2003, case 2.6.1-3

Case 9 – Pitched cambered glulam beams

Description of Structure

The primary roof structure of an industrial building consists of pitched cambered glulam beams with a span of 29.5m.

Description of failure

About 4 years after inauguration, large cracks and extreme deflection were observed in one of the beams. The beam was supported at mid-span by production devices that probably prevented larger deflection and bending failure of the beam. Minor cracking was observed in the other beams.

Original investigation performed and conclusions

The cracking in all the beams was probably caused by fast drying from the initial MC of about 12% to the present MC of 6-8%. However, the large cracking over the entire width of the deflected beam was not only caused by drying. Investigation of the loads at the time of failure revealed that in the deflected beam the tension stresses perpendicular to the grain were exceeded already by the permanent loads (without snow load). All the beams are loaded with dead load, plus installations (pipes, lamps and electrical wires). However, the deflected beam also has to carry 3 heating aggregates (located at mid-span and 6m from the supports respectively), acting as 4.6 kN point loads (suspended in the lower part of the beam). These point loads had not been considered in the design.

Disregard of loads resulting from technical equipment is quite common. When doing a structural design, the designer has to know about the technical equipment and its loads. However, it is often decided about the technical equipment after the design has been completed.

Source

Dröge G. & Dröge T.: Schäden an Holztragwerken, Schadenfreies Bauen, Band 28, Fraunhofer IRB Verlag, 2003, case 2.6.2-1

Case 10 – Bending failure in Gerber beam in industrial building

Description of Structure

A 125 m wide industrial building is covered by continuous glulam beams with Gerber type hinges in every second span (span 22.6 m). The roof is completely flat, leading to large water pools after rain. Glulam beams and purlins have been designed for uniform load comprising of dead load, extra load due to fixtures and fittings and snow load. The beams have been designed with full utilization both in the bay and at the support.

Description of failure

About 6 years after the first failure (described in case 7), one beam collapsed at mid-span in a span without internal hinges during a heavy rainfall (thunderstorm). The roof structure was damaged by the deflection preceding the collapse, resulting in cracks in the roof cladding. This resulted in drainage of water into the building, reducing the load on the roof. The total collapse could be prevented by temporary support with extra timber columns.

Original investigation performed and conclusions

The bending failure was associated with splitting along a considerable length of the beam. This indicates that the failure is not caused by bad material quality but by excessive loading. After long rainfalls, water depths of 10cm were observed in some spans of the roof structure, while neighbouring spans are free from water load. This was due to bad positioning of the draining system. Draining pipes were not placed in the lowest position of the roof structure, but very close to the supports. If a span without internal hinges is loaded with water load while the neighbouring spans (with hinges) are not loaded, the beam does not act as a continuous beam any more, but as a simply supported beam (1 span). For a simply supported beam, the bending moment is three times higher than for the continuous beam with the same load. This high bending moment resulted in failure.

The beam was restored by help of two steel beams that were connected to the glulam beam on either side. The cracks were injected with synthetic resin. However, the reason for the failure was not eliminated by that. A proper solution would be a new positioning of the drainage system with runoff pipes in the intercept point of the diagonals of the single spans. However, this solution was regarded as too expensive. Instead, all the spans without internal hinges were reinforced by extra supports at mid-span.

Source

Dröge G. & Dröge T.: Schäden an Holztragwerken, Schadenfreies Bauen, Band 28, Fraunhofer IRB Verlag, 2003, case 2.6.2-2

Case 11 – Collapse of nail-plate trusses during erection of a retail building

Description of Structure

A 60 m long and 30 m wide retail building is roofed by 59 nail-plate trusses, 1m on centre. At mid-span, the height of the trusses is 6 m.

Description of failure

After erection of 50 of 59 trusses, the 5 last trusses erected collapsed in slow-motion during a break. The trusses broke.

Original investigation performed and conclusions

According to the structural design, the lateral bracing of the building is provided by lateral trusses at each 15m, diagonal chords between the lateral trusses, purlins with centre distance of 610mm as well as boards in longitudinal direction of the building, connecting the vertical struts in the main trusses (each vertical strut shall be braced by 3 boards). The bracing system is also shown in Figure 11-1. At the time of collapse, only some of the purlins had been installed. Further-more, of the three boards connecting the vertical struts, only one board was present in each half of the truss (instead of 6). Not all the diagonal bracings between the lateral trusses had been built in. Due to the missing purlins, the buckling length of the upper chord was much too long, resulting in failure. There existed no erection instructions.

Apart from the missing lateral bracing, low quality can be seen as one reason for the failure. Especially in the lower chord, loaded by bending moment and tension force, good quality is crucial. Some of the lower chords and diagonal tension struts had to be reinforced by boards fixed on the two sides of the original member because of high knot area ratio and therefore reduced effective cross-section.

Analysis revealed that full degree of utilization was attained in most of the chords for full load. However, as a large part of the total load consists of permanent loads, the long term strength of the chords would probably not have been sufficient. It was possibly sheer luck that the structure collapsed during erection, making strengthening possible.

Source

Dröge G. & Dröge T.: Schäden an Holztragwerken, Schadenfreies Bauen, Band 28, Fraunhofer IRB Verlag, 2003, case 2.7.1-2

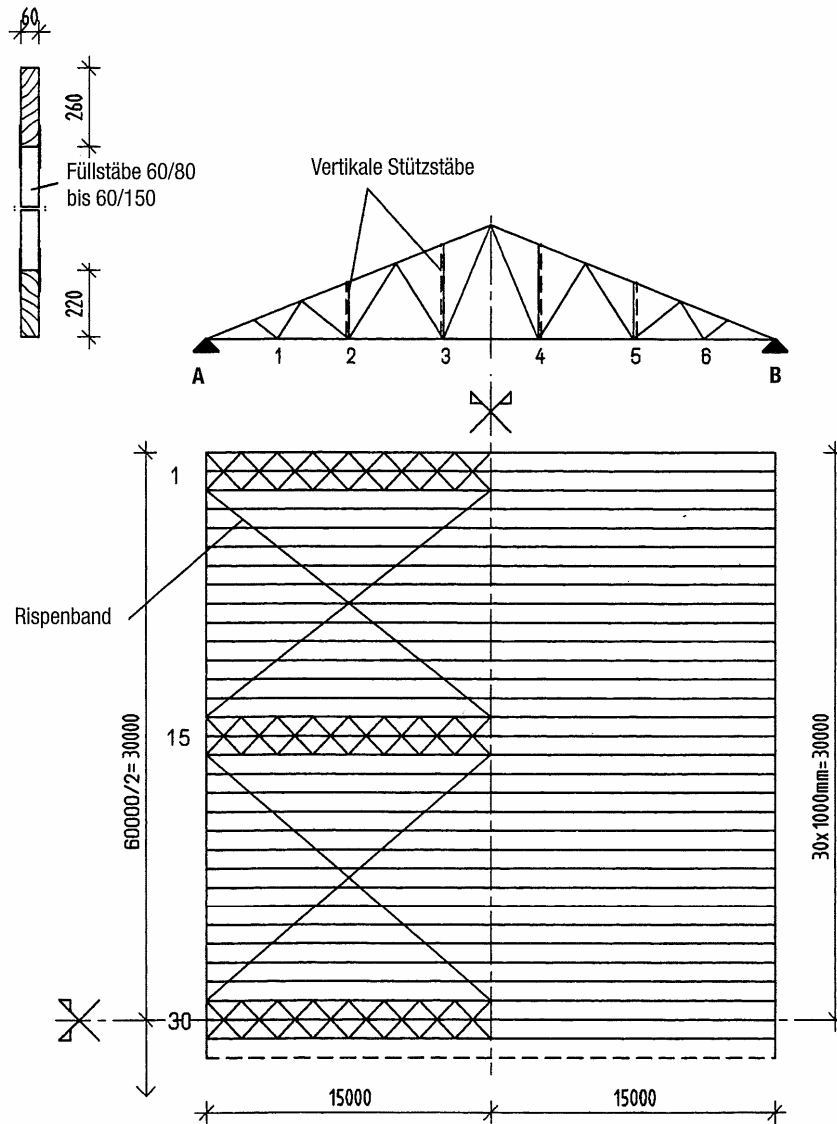

Figure 11-1. Bracing of roof structure. Picture from Dröge G. & Dröge T.: Schäden an Holztragwerken, Schadenfreies Bauen, Band 28, Fraunhofer IRB Verlag, 2003.

Case 12 – Three-hinged glulam frame – collapse during erection

Description of Structure

A hall was built with three-hinged glulam frames.

Description of failure

During the erection of the three-hinged glulam frames, the structure collapsed completely after a thunderstorm.

Original investigation performed and conclusions

The present wind velocity was lower than the design value, meaning that the collapse was not caused by extreme loading. The investigation revealed insufficient lateral bracing: only parts of the purlins and diagonal bracings had been provisionally attached to the beams. The vertical steel bracings in the walls were already in place and fastened to the frame corners. However, as the wind direction was almost perpendicular to the plane of the frame, the fastening could not transfer the wind load to the vertical bracing but the frame corner broke off.

During the erection, significantly higher wind loads act on the frames than in a finished building, due to the large number of frames after each other, which all will be directly loaded by wind perpendicular to the frame plane. This is not the case once the roof is installed. This means that special bracing is needed during erection, but this was not the case. In addition, some of the bracings applied (vertical bracing in walls) would not even have worked in the finished building.

The construction could not be restored, but had to be dismantled.

Source

Dröge G. & Dröge T.: Schäden an Holztragwerken, Schadenfreies Bauen, Band 28, Fraunhofer IRB Verlag, 2003, case 2.7.5-1

Case 13 – Collapse of roof element in a school building

Description of Structure

A school building has a roof consisting of standard roof elements (span 3.5 m) consisting of three plywood panels (19mm each) that are supported at one end by a steel beam and at the other end by an angle profile of steel that is fastened to a glulam beam with screws 300mm on centre.

Description of failure

An early summer morning, during a heavy rainfall, a roof area about 3m x 7m collapsed. The end of the panels that was supported by the angle profile fell down whereas the other end still rested on the steel beam. The water on the roof emptied into the room below.

Original investigation performed and conclusions

The rainfall at the time of failure gave about 60mm precipitation in that region. The investigation showed that the drainage hole in the collapsed roof elements was blocked, resulting in a water load. The water could have been drained by the way of neighbouring drainage pipes, however, water depths of about 25cm at mid-span and about 10cm at the support would be needed to pass the ridge to the next draining pipe. The investigation of the supports showed that the screws connecting the angle profile to the glulam beam failed, with the threaded part remaining in the glulam beam. The failure surfaces of the screws were not shiny, and one screw had corroded. This indicates that the screws had failed prior to collapse of the roof. For thorough investigation, screws were taken from another part of the roof. Of five screws, only two could be obtained whole, the other three were broken directly under the screw head, also having non-shiny failure surfaces and corrosion on one out of three. Tests on the screws showed a higher bending strength and withdrawal strength than required in the code, but it could also be shown that there is high risk for failure below the screw head due to torsion during screwing.

Investigation of the design revealed that some minor errors have been made, affecting strength both negatively and positively. Firstly, a dead load of 0.4kN/m^2 for standard roof elements was used. However, a thin steel plate had been replaced by three plywood panels, which increased the dead load by about 0.3kN/m^2 . Furthermore, the distance between screws and the corner of the angle profile was 53mm instead of 80mm. However, in the design the positive influence of stabilization from neighbouring roof elements was not taken into account and the load eccentricity on the angle profile was conservatively estimated. Both these factors will influence the capacity in a positive manner. In conclusion, the reason for the collapse cannot be found in the design.

A design calculation showed that the roof could resist a water load of 250mm water depth without failure.

It is concluded that the collapse of the roof is caused by execution error. Some of the screws had failed beneath the screw head due to torsional moment during screwing exceeding the strength and had been left in the structure despite their low ability to carry loads.

If the drainage pipe would not have been blocked, the roof would not have collapsed that day, but the water load present on the roof could have been resisted if the execution of the screw joint had been correct.

Additional conclusions and comments

A paper summarizing this case and giving more information about properties of different screws and good ways of execution to prevent failures like this is available.

Source

Hans Jørgen Larsen, Skovvangsskolen Danmark, January 2005, (In Danish).

Case 14 – Failure of a double-tapered glulam beam in a sports hall

Description of Structure

The roof structure of a 45m x 22m large sports hall consists of eight 22m span double-tapered glulam beams placed at a centre distance of 5m. The beams have a cross-section of $b/h=140/1500$ mm at the ridge and $b/h=140/1050$ mm at the supports. The beams contain 300 mm wide circular holes for warm-water pipes 2 m from the ridge (on both sides) at about mid-depth of the beam. The warm-water pipes transport water at 80°C to heating aggregates. The pipes are insulated, however, at the holes, the insulation is missing, resulting in direct contact between the pipe and the timber.

Description of failure

About 19 years after inauguration, the owner of the hall noticed large deflections in a part of the roof structure. One beam had very many cracks with small to medium depths in the glulam as well as a long through crack from one support to the first hole (about 10 m length). This crack divided the beam into two beams. The beam had to be supported to prevent collapse. All the other beams showed smaller or larger cracks, especially near the holes.

Original investigation performed and conclusions

Several parameters could have caused this failure. One possible failure reason is the presence of the holes in the glulam beams. The control engineer recommended strengthening for the holes, but this was never executed. The holes are acceptable according to the code valid during the original construction. A calculation revealed that the stresses perpendicular to the grain caused by full load could not have led to the cracking. Therefore, strengthening would neither be necessary according to the new code. The failure must therefore firstly have been caused by a reduction of the cross-section due to drying cracks.

It is quite common that at the time of inauguration, hall buildings are heated excessively. This can lead to drying cracks. Furthermore, the warm-water pipes without insulation cause rapid drying near the holes, initiating cracking. However, this cannot be the only reason for failure, as this should have caused failure earlier than after 19 years. In the end of the lawsuit, it was found out that a pipe burst had occurred in the hall shortly before the failure. This led to high relative humidity in the hall. Due to the drying cracks, the beams had a larger surface that could pick up moisture quickly. The swelling increased the already existing cracks. To overcome the problems of the pipe burst, the hall had been heated excessively to make it ready for use in a short time. This resulted in very fast drying, inducing new cracking, which reduced the load-bearing capacity of the beam. The separating crack has probably been caused by too high shear stresses, as it is initiated at the support and ends near the mid-span of the beam. Possibly, the shear

forces resulting from full load could be increased by gymnastic equipment and heating aggregates attached to the beams, but this was not investigated.

Additional conclusions and comments

This failure resulted in a very complicated lawsuit that finally was concluded with a settlement. The failure is probably caused by inadequate consideration of climatic conditions, i.e. excessive drying, but as crack surfaces and moisture contents were not investigated, it is impossible to say exactly when the cracks were initiated.

Source

“Tragversagen von Brettschichtholz-Trägern der Dachkonstruktion einer 19 Jahre alten Sporthalle”, Dröge, G., Dröge, Th., in: Bauschadensfälle, Band 6, Günter Zimmermann und Ralf Schuhmacher (Hrsg.); Stuttgart: Fraunhofer IRB Verlag, 2004

Case 15 – Collapse of suspended ceiling in a swimming hall

Description of Structure

A swimming hall with a primary structure of prestressed concrete is equipped with a suspended wooden ceiling (span 4.7 m). Battens are attached to the primary structure by distance elements and nails as well as with wires. Ceiling boards 90x19 mm² are fastened to the battens via wooden distance elements (perpendicular to the battens) with the help of nails 3.4mm with 90mm length. On top of the ceiling elements, 30 mm mineral fibrous insulating material was placed for acoustical reasons.

Description of failure

Shortly after a school class had left the swimming hall, a 4.65m x 17.5m large portion of the ceiling fell down into the basin and onto the edge of the basin.

Original investigation performed and conclusions

The investigation revealed that smooth nails with axial loading from the ceiling have been used in this construction. The nails connecting the ceiling boards with the battens had failed. Smooth nails should not be loaded axially. Due to the changing relative humidity in the swimming hall, the withdrawal strength decreases with time. Additionally, some of the nails had not been driven completely into the wood, but there were gaps of up to 9mm between the battens and the ceiling boards, reducing the penetration depth and therefore also the withdrawal strength and giving rise to increased risk for corrosion. In one row of nails of the collapsed element, one nail was not present, while the neighbouring nail was driven at an angle into the wood, giving a penetration depth of only 20mm. Prior to the collapse, water leakage had been observed in the collapsed element, which could have reduced the withdrawal strength of the nails. However, also in parts of the roof that had not been damaged by water leakage, some of the nails were creeping out of the timber.

The reason for collapse is wrong execution with smooth nails instead of ringed nails.

The structure was restored with additional suspension wires and new, appropriate nailing.

There is no information about the design of the joints (ringed nails or smooth nails).

Source

”Abgehängte Holzdecke in einem Hallenbad. Abfallen der Decke infolge unzureichender Befestigung”, Brand, B, in: Bauschäden-Sammlung, Band 6, G. Zimmermann (Hrsg.), Stuttgart: Fraunhofer IRB Verlag, 1986, p.108-109

Case 16 – Collapse of suspended ceiling in a school building

Description of Structure

The roof structure of a school building (finished early 1970) consists of lattice girders (DSB-Träger) with a centre distance of 1090 mm. A suspended ceiling consisting of boards with tongue and groove is fastened to the girders. A plywood plate is fastened to the side of the lower chord of the girder with clamps (10mm back, 50mm shafts) producing distance between the girder and the ceiling. Battens are then fastened to the plywood with clamps (10mm back, 50mm shafts) and also the boards are fastened to the battens with clamps (4.5mm back, 20mm shafts) that are located in the tongues and grooves. Lamps are attached to the boards with screws.

Description of failure

After almost two years of use, the whole ceiling of one classroom fell down. The clamps connecting battens and plywood were withdrawn.

Original investigation performed and conclusions

The investigation showed that the clamps connecting battens and plywood were withdrawn. Clamp holes could be seen in the plywood. However, in one piece of plywood near the teachers desk, no holes were observed, indicating missing clamps.

Short-term tests were carried out using specimens that resembled the structure of the ceiling with boards, battens and plywood and the same clamps as used in the original structure. The long-term load-carrying capacity is assumed to be 50% of the short-term load-carrying capacity in the test. The clamp connection can hardly carry the dead load of the false ceiling (boards and battens), let alone the additional loading from the lamps. Clamps with a missing neighbouring clamp are then overloaded.

Other factors that could possibly reduce the load-carrying capacity of the clamps are moisture content of the timber, orientation of annual rings, wind loads, vibrations and so on. Clamps are not approved as a connector in the German code DIN 1052, therefore, screws should have been used in these connections.

The structure was renovated with screws, which were screwed through the boards and timber blocks into the lower chord of the girders. There is no information whether the design was done with screws or clamps. As clamps are not approved as connectors according to the code, it is assumed that the reason for the collapse was execution error.

Source

”Untergehängte Decke aus Holzschalung. Abfallen der Decke infolge mangelhafter Befestigung”, Radovic, B, in: Bauschäden-Sammlung, Band 1, G. Zimmermann (Hrsg.), Stuttgart: Fraunhofer IRB Verlag, 1973, p.111-112

Case 17 – Collapse of timber balconies

Description of Structure

An apartment building has timber balconies on the west and south side of the building. The balconies consist completely of timber and are fastened to the massive walls of the building with a horizontal timber tension bar anchored in the wall and diagonal compression timber elements resting on steel supports in the wall.

Description of failure

About 10 years after inauguration, 3 of 15 balconies suddenly fell down.

Original investigation performed and conclusions

The failure was initiated in the tension anchorage of the balconies. The investigation revealed that the joint between timber beam, steel anchorage and wall was placed inside the wall, behind the insulation system. This means that moisture can easily get into the construction, but that drying is very slow. This had led to decay at the end of the timber tension bars, resulting in failure of the connection between timber and steel.

Horizontal surfaces and plants on the walls, creating a moist climate, add to the decay.

The reason for this collapse must be wrong design, not taking into account the risk for decay when moisture is present. The error was classified both as design error and inadequate consideration of climatic conditions.

The balconies were restored placing the connections between timber and steel parts outside the wall, making it possible to dry, decreasing the risk for decay. The 12 balconies that had not failed are supported by steel columns and inspected regularly.

Source

”Balkone als Holzkonstruktion – Einsturz durch fehlerhafte Befestigung”, Philipps, G, in: Bauschadensfälle, Band 3, G. Zimmermann und R. Schumacher (Hrsg.), Stuttgart: Fraunhofer IRB Verlag, 2003, p.89-93

Case 18 – Collapse of roof of a two-family house

Description of Structure

A two-family house is built in southern Germany at a quite high and exposed place. The house was not completely finished, but walls, windows and roof were installed.

The roof with 30° inclination has a 2m overhang on the gable side of the house.

Description of failure

During a heavy windstorm in January with a wind velocity of maximum 120km/h, the roof overhang lifted on one side and broke the ridge beam. The roof landed on neighbouring buildings which were damaged. The gable wall, now free-standing, tilted by the wind load. All eaves were also destroyed.

Original investigation performed and conclusions

The investigation showed that the design wind load was used in the original design. However, in the German national code, apart from tabulated values of the wind velocity at a certain height at a certain location, there is a remark saying that increased values should be used for buildings that are specially exposed. However, this was not considered in the present case.

The investigation of the roof structure showed that not all the wind anchorage joints between rafters and roof beams were carried out according to the code, but only with smooth rafter-nails with a length of 200 mm. The design load on the rafter nails for axial uplift was exceeding the load-bearing capacity with 93%. However, if the actual wind velocity were used in the design, an additional increase of 38% is found, giving 128% higher load than the nails were designed for. This calculation does not include the extreme suction values that should be used at the edges of the building. If higher design wind loads had been used (for elevations greater than 600m above sea level), the design wind load would have been higher than the actual wind load and the roof would not have failed.

This collapse is due to a combination of design error – value of wind load – and execution error – design of the joints between rafters and roof beams. However, on the design drawings, only the joints between rafters and middle roof beam were mentioned.

Source

”Holzpfetten-Dachstuhl – Zerstörung durch Sturm infolge unsachgemässer Verbindungsmittel”, Philipps, G, in: Bauschadensfälle, Band 3, G. Zimmermann und R. Schumacher (Hrsg.), Stuttgart: Fraunhofer IRB Verlag, 2003, p.59-64

Case 19 – Complete failure of roof in sports hall

Description of Structure

A sports arena, built 1979, consists of 16 glulam arches spanning 88 m. The length of the arena is 116 m. The arches (1.85 m height), spaced about 8 m (24 ft), are interconnected by girders (0.94 m depth) and purlins spaced at about 1.3 m (4 ft). The connections between arches and girders are designed with angle irons, bolted to the arch with several bolts and with three bolts to the girder.

Description of failure

When 90 % of the structure was completed, the entire arch roof collapsed.

Original investigation performed and conclusions

The investigation showed that missing bolts in the arch-girder-connections were a key factor to the collapse.

The arches consist of three pieces, which were erected consecutively. Firstly, one end part was lifted with a crane, put on the support and bolted to the girders. In this connection, two out of three bolts were omitted temporarily during construction. The other end piece was lifted in the same way. Then, the middle part was lifted with a third crane and connected to the other two parts. Additionally, the girder connections were established (with one bolt per connection). The contractor claimed that omitting two out of three bolts temporarily was approved by the supervising engineer. To compensate for missing bolts, steel plates across arches and girders were provided for temporary bracing. However, only 27 % of the steel plates had been built-in as required. In some other steel plates, several of the holes (24mm in diameter) had been enlarged at the building site to 65mm.

At the time of failure, 53% of the bolts were missing. Of the bolts in place, 76% had no nuts. Moreover, of the nuts in place, many were only finger tightened.

Missing bolts were the triggering cause in this collapse, however, other improper construction practices were found, such as inadequate bracing and piling of decking material on the roof.

Additional conclusions and comments

Five dead, 16 injured.

The structure was rebuilt in the original design.

Source

Feld, Carper, 1997: Rosemont Horizon Arena sports complex
Ratay, R. 2000: Forensic Structural Engineering Handbook, McGraw-Hill: Case Study 5: Rosemont Horizon Arena, Rosemont, Illinois.

Case 20 – Failure of roof

Description of Structure

The roof of a recital hall consists of composite membrane over isolation, a lightweight concrete slab (75mm) and 19 mm plywood decking. The load-bearing structure consists of wood trusses (1m deep at supports, 1.6m at midspan), spanning 24 m.

Description of failure

In 1990, the complete roof collapsed.

Original investigation performed and conclusions

Heavier than anticipated dead loads led to failure: the actual dead load was about 158% of the design dead load. Additionally, roof diaphragm connections were inadequate for stability and load distribution. Nailing of sheathing was absent in some places and if present, it was found to be inadequate.

Source

Feld, Carper, 1997: Recital hall at Long Beach Campus at California State University

Case 21 – Collapse of burning building

Description of Structure

The building was moved in the late 1950's.

Description of failure

Sudden collapse occurred during fire before the timber members had suffered severe reduction of their cross sections.

Original investigation performed and conclusions

In the original building, the connections between roof trusses and columns were made with shear rings. Those invisible connectors were obviously not present in the re-built structure.

Additional conclusions and comments

Bolts in shear-ring connections only serve to keep timber pieces together, but do not transfer loads.

Source

Feld, Carper, 1997: Boston failure 1982 (original source: Moore 1991)

Case 22 – Collapse of roof in school building

Description of Structure

A one-storey school building is built in 6 sections with adjacent roofs at various levels. The roof structure consists of roof deck (tongue- and-groove cementitious wood fibre planks) and joists (bottom-chord-bearing open-web roof joists with wood chords and steel-tube web members).

Description of failure

On the first day of school in the new building, one part of the roof collapsed after a heavy snowstorm the night before. Visible deflection of the roof provided warning and made evacuation possible.

Original investigation performed and conclusions

In the design, drifting snow loads were not considered. The failed roof had to carry 2.2 times the design snow load as snow had been blown down from a neighbouring (higher) roof, giving a snow depth of 2.1m.

Source

Feld, Carper, 1997: Junior high school, Waterville, Maine (original source: Zallen, 1988)

Case 23 – Collapse of ceiling and entire roof

Description of Structure

A ceiling consists of fire-protected gypsum boards, which are nailed securely to closely spaced wood joists. The joists are securely nailed to the bottom chords of long-span bowstring timber trusses.

Description of failure

A malfunctioning sprinkler system flooded the interior attic space. This caused a ponding failure of the ceiling, and resulted finally in failure of the long-span roof.

Original investigation performed and conclusions

The good structural integrity of the ceiling system was detrimental to the performance of the roof structure. High loads on the ceiling were transferred to the lower chord of the bowstring trusses.

Additional conclusions and comments

Design and execution error

Source

Feld, Carper, 1997: Ceiling failure (original source: Estenssoro, 1989)

Case 24 – Collapse of glulam frame

Description of Structure

A hangar was constructed in 1998 with a span of 50 m and a length of 65 m. The structure was a three-hinged glulam frame with triangular frame corners (tension and compression studs). The structure with a roof pitch of 18° was symmetrical, and the roof was covered with corrugated steel plates. The ridge joint was made with horizontal steel plate and nail plates on either side.

Description of failure

On December 29th, 2003, one of the frames failed and parts of the roof collapsed.

The failure started at the ridge joint, at the lower edge of the horizontal steel plate and led to delamination of the beam, then leading to bending failure.

The building could be evacuated before the collapse.

At the time of collapse, the snow load on the roof was not symmetrical, about 50 cm on one side and 15 cm on the other side. Snow depth on the ground was 80 cm and the design snow load was 2.5kN/m².

Original investigation performed and conclusions

The investigation of the design showed that the hangar was not designed for unsymmetrical snow load. Therefore, the structure was designed for too low values of bending moment, shear force and normal force. Especially the ridge joint could not take up the high shear forces due to unsymmetrical load (design load exceeded by 100%). At the time of failure, the capacity of combined bending moment and normal force was exceeded by 25%.

Furthermore, some construction details were wrong in the ridge joint:

1. too small contact area due to inclined sawing at the joint
2. horizontal steel plate leading to splitting of the beams
3. outer steel plates were too small and the nails were positioned with too small distances

In addition, the support of the beams could not resist the horizontal forces present in the frames.

In conclusion, the collapse is caused by design (wrong load case), especially of the ridge joint and the gable support.

Source

Eivor Skaug, 2004: Skader på moderne trekonstruksjoner i Norden (Failures of modern timber structures in the Nordic countries), Masteroppgave 2004, Fakultet for ingeniørvitenskap och teknologi, Institutt for konstruksjonsteknik, NTNU (in Norwegian), case: Torp Hangar

Case 25 – Collapse of tennis hall

Description of Structure

A tennis hall was built in 1999 with a span of 36 m, length 50 m and height about 10 m. The structure consisted of glulam beams, supported by glulam columns. The roof was covered with self-bearing steel plates, insulation and plastic film. Bracing consisted of diagonal bracing in the roof plane and in the walls.

Description of failure

On February 1st, 2000, about 1/3 of the roof structure collapsed due to overload. The second roof beam had been observed to deflect prior to collapse and failed in bending (material failure). Due to load redistribution to the rest of the structure, a larger part of the building failed under high snow load. Even the walls supporting the collapsed roof part collapsed. The building could be evacuated before the collapse.

Original investigation performed and conclusions

The investigation of the design of the tennis hall showed that the structure was designed for a snow load of 3.5 kN/m² (on ground). However, the snow load at the time of failure was measured to be between 5.68 and 7.62 kN/m². Dead load was 0.562 kN/m². Calculations showed that the building collapsed due to overload.

Source

Eivor Skaug, 2004: Skader på moderne trekonstruksjoner i Norden (Failures of modern timber structures in the Nordic countries), Masteroppgave 2004, Fakultet for ingeniørvitenskap och teknologi, Institutt for konstruksjonsteknik, NTNU (in Norwegian), case: Tromsø tennishall

Case 26 – Collapse of glulam beams

Description of Structure

A shop was roofed by glulam beams with dimensions 180 mm x 733 mm with a slope of 2 %.

Description of failure

Two of the beams collapsed.

Original investigation performed and conclusions

Investigation of the roof showed that water runoff pipes were plugged with leaves. Directly after the failure, the water depth in the shop was about 1 cm

The remaining beams were heavily damaged with severe cracking.

An investigation of the design calculations and the failed beams showed that the beams had been executed in quality class 2 (German) instead of quality class 1 as specified in the design. However, even quality class 2 beams should not have failed even at higher water loads present when the collapse occurred. An investigation of the beams' quality showed that larger than allowed knots and annual ring widths were present in some outer lamellae. Furthermore, some of the finger joints were of low quality. Additionally, some of the lamellae were not jointed at all. This was allowed in an older version of the german code, but the required distance of at least 50cm between those "joints" was not met.

The failure is a combination of wood material performance, manufacturing errors in factory and on-site alterations.

Source

Colling, 2000: Lernen aus Schäden im Holzbau, Teil B: Typische Beispiele. Deutsche Gesellschaft für Holzforschung e.V., ISBN 3-934915-00-0, Schadensbeispiel 2-01

Case 27 – Bending failure in glulam beams

Description of Structure

A swimming hall was built in 1975/76 with glulam beams (135 mm x 733 mm), placed at 4 m centres and spanning 11.5 m. Purlins (73 mm x 173 mm) were placed between the beams at 0.6 m centres. Insulation was placed between the beams (above the ceiling).

Description of failure

In the end of March 2000, bending failure occurred in three of the roof beams. The failure started in the finger joints in the outer lamella. The purlins had large deformations.

Original investigation performed and conclusions

The building was designed for a snow load of 2.5 kN/m². However, the snow load at failure was 3.5 kN/m².

The investigation showed gaps in the finger joints, which points at bad quality. The timber and glue line quality may have been reduced by high variations in relative humidity (shrinkage, swelling). Overloading in earlier years could possibly have led to cracks in the beams and therefore weakened them.

The collapse was caused by overloading and weak finger joints.

Source

Eivor Skaug, 2004: Skader på moderne trekonstruksjoner i Norden (Failures of modern timber structures in the Nordic countries), Masteroppgave 2004, Fakultet för ingenjörvitenskap och teknologi, Institutt for konstruksjonsteknik, NTNU (in Norwegian), case: Namsskogen svømmehall

Case 28 – Collapse of sports hall

Description of Structure

The sports hall was built in 1977 with three-hinged glulam arches (span 24.4 m, length and height of building 45 m and 9.3 m respectively). The arches have dimensions 80 mm by 434 mm and are placed at 2.39 m centers. In 1996 the hall was changed from being not insulated and only covered by a membrane to a permanently insulated building.

Description of failure

On March 18th, 1999, large parts (about two thirds) of the hall collapsed due to material failure in the arches. One third of the hall remained standing; however, it experienced large deformations on the gable wall.

Original investigation performed and conclusions

The investigation of the design and the collapse showed that the building had been designed non-insulated with a sleek membrane which would make any snow melt and glide down. Thus, snow load would not be present on the roof. When renovated, the membrane was replaced by an insulated roof with corrugated steel plates. The new roof cover was heavier. In addition, snow did not melt as much as earlier with the non-insulated roof. Thus, both dead load and snow load became larger than that used in the original design. The renovation was carried out without strengthening of the load-bearing structure. Calculations showed that the building had poor design for the snow load in that region also when originally built.

Design was done for dead load of 0.035 kN/m² and snow load of 1.7 kN/m² (with shape factor 0.7). At the time of failure, dead load was 0.37 kN/m² and snow load was between 2.2 and 3.4 kN/m².

Source

Eivor Skaug, 2004: Skader på moderne trekonstruksjoner i Norden (Failures of modern timber structures in the Nordic countries), Masteroppgave 2004, Fakultet för ingeniörvitenskap och teknologi, Institutt for konstruksjonsteknik, NTNU (in Norwegian), case: Løkenåshallen

Case 29 – Large deflection of roof in sports hall

Description of Structure

In 1997, a sports hall was built with length 70 m, width 54.4 m (span), total height of 13.6 m and arch height of 11.7 m using three-hinged glulam arches. The arches (depth of cross section 1166 mm) were spanning 54.4 m and placed at 7 m centres. The roof was covered with steel sheathing. Locally at the site of the hall, extreme climatic conditions prevail.

Description of failure

On March 13th, 1998, the arches deflected about 20 to 30 cm. The steel sheathing was severely damaged. The load bearing structure was only slightly damaged, however, as an example, the emergency exit doors were jammed due to large deflections.

Original investigation performed and conclusions

At the site of the building, high winds prevail and move snow from the ground onto the leeward side of the roof. This case is not included in the code and was thus not included in the design either. Before construction, it was not known that the wind and snow conditions could develop in this negative way. The arches were designed for a balanced snow load (maximum value in serviceability limit state 3.48 kN/m^2), however, design for triangular snow load distribution would have been more advantageous (maximum value 7.4 kN/m^2).

Large deflections occurred due to design of load bearing structure and roof cover (steel plates) using too low loads.

Additional conclusions and comments

Snow has to be removed from the roof to prevent unsymmetrical snow load in the future.

Source

Eivor Skaug, 2004: Skader på moderne trekonstruksjoner i Norden (Failures of modern timber structures in the Nordic countries), Masteroppgave 2004, Fakultet for ingeniørvitenskap och teknologi, Institutt for konstruksjonsteknik, NTNU (in Norwegian), case: Lofothallen

Case 30 – Cracks in glulam beams

Description of Structure

The hotel and restaurant building was built in 1992. The load-bearing structure consists of glulam beams (73 mm by 198 mm) at 6 m centres with different spans. The longest span is 14 m. The building is about 40 m long and 28 m wide. Purlins span between the glulam beams, which are supported by columns. The building has the shape of a crescent and is covered with peat.

Description of failure

In April 1998, two main beams cracked as bending moment and shear capacities were exceeded. The failure started at one support of the glulam beams.

The purlins deflected excessively.

Original investigation performed and conclusions

The investigation revealed the following: The building was designed for a snow load of 2.5 kN/m^2 , whereas the local design load is 5.5 kN/m^2 (return period of 20 years). The snow load at time of failure is not known.

The joint between column and beam was carried out with external steel plates (dowel-type fasteners). However, due to the pitch of the roof, the contact pressure from the column was transferred with an angle to the fibre direction, resulting in unfavourable stress distribution.

The failure is due to design (too small snow load considered) and an unfavourable design of the beam support.

Source

Eivor Skaug, 2004: Skader på moderne trekonstruksjoner i Norden (Failures of modern timber structures in the Nordic countries), Masteroppgave 2004, Fakultet for ingeniørvitenskap och teknologi, Institutt for konstruksjonsteknik, NTNU (in Norwegian), case: Gaiastova

Case 31 – Lifting roof

Description of Structure

The museum was built in 1992 with a length of 83 m, width of 9 m and height of 7.5 m. The pitched roof structure consists of rafters, collar beam and struts. The rafters are placed with 1.2 m centres, and the roof pitch is 45°. The building is placed on the top of a hill.

Description of failure

On October 12th, 1996, the southwestern part of the building was severely damaged as the roof lifted and the timber structure was pulled apart.

Original investigation performed and conclusions

The investigation of the failure showed the following:

1. In the design, wrong assumptions about wind speed (ULS: 47 m/s) and inner and outer wind pressures had been used. Wind speed at failure was 55 m/s. The assumed height above ground was wrong (6 m instead of 22.5 m due to the exposed position). For a height of 22.5 m above ground, the design wind speed would have been 56 m/s.
2. The building was not designed for wind against the corner.
3. The design was done for heavy roof (4.6 kN/m²) and roof pitch of 33.6°. It could not be seen from the calculations that the building would be built with light roof and roof pitch of 45°.

In conclusion, this collapse was caused by insufficient design of the bracing system due to wrong assumptions about the wind loads.

Source

Eivor Skaug, 2004: Skader på moderne trekonstruksjoner i Norden (Failures of modern timber structures in the Nordic countries), Masteroppgave 2004, Fakultet for ingeniørvitenskap och teknologi, Institutt for konstruksjonsteknik, NTNU (in Norwegian), case: Vikingmuseet på Borg

Case 32 – Collapse of sports hall

Description of Structure

In 1993, a building that originally had served as a temporary exhibition hall in Trondheim since 1984, was erected in Oppdal as a sports hall. The structure consisted of three-hinged frames of glulam, placed at 6 m centres, with a span of 24 m. Inclined steel struts were placed between frame support and frame beam, see figure 32-1.

The building was not designed for snow load in Oppdal, however, extra wind bracing was provided.

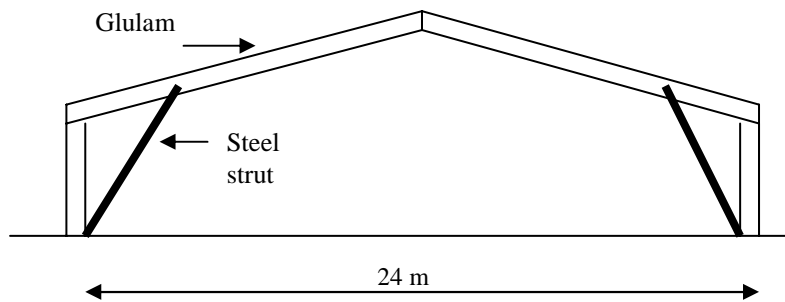

Figure 32-1. Schematic of frame structure

Description of failure

In January 1995, the bracing for wind against the gable fell down and led to instability of the building. In the following three days, the whole building collapsed due to heavy wind. The building was completely damaged.

Original investigation performed and conclusions

In Oppdal, there is some special effect, amplifying the wind loads when the wind blows from a certain direction. The building had been strengthened for that wind, and the structure did not fail in a storm in 1993. However, in 1995, the wind blew from another direction, blew the gate in the gable open and created an increased wind pressure (30% increase compared to the “closed” building”).

The failure is due to heavy wind and insufficient bracing.

Additional conclusions and comments

The building was delivered and designed by the same company that also designed Steinkjer Ridehall (case 34). The design was identical, apart from increased bracing in the present case. Steinkjer Ridehall collapsed the same year under snow load.

Source

Eivor Skaug, 2004: Skader på moderne trekonstruksjoner i Norden (Failures of modern timber structures in the Nordic countries), Masteroppgave 2004, Fakultet for ingeniørvitenskap och teknologi, Institutt for konstruksjonsteknik, NTNU (in Norwegian), case: Oppdal curling-/industrihall (1)

Case 33 – Collapse of sports hall during construction

Description of Structure

This is the re-built hall from case 32. The structure consisted of trusses, placed at 6 m centres, with a span of 24 m, supported by walls. Inclined steel struts were placed between wall support and truss.

Description of failure

During construction, heavy wind led to collapse of the structure. One person was injured. The building was completely damaged.

Original investigation performed and conclusions

During construction, when the bracing had not been installed yet, a wind blow made the structure collapse. The collapse was caused by missing bracing and missing anchorage to the ground (poor erection principles).

Source

Eivor Skaug, 2004: Skader på moderne trekonstruksjoner i Norden (Failures of modern timber structures in the Nordic countries), Masteroppgave 2004, Fakultet for ingeniørvitenskap och teknologi, Institutt for konstruksjonsteknik, NTNU (in Norwegian), case: Oppdal curling-/industrihall (2)

Case 34 – Collapse of horse-riding building

Description of Structure

In 1989, a horse-riding building was erected with a length of 42 m and a span of 24 m. The load-bearing system consists of three-hinged frames placed at 6 m centers. Beams (140 mm x 733 mm) and columns (140 mm x 200 mm) are made of glulam, struts between column support and beam in steel. The bracing consists of truss bracing in the middle bay in both roof and walls. Purlins (glulam, 90 mm x 300 mm) span over the beams and columns. Walls and roof are covered with a plastic membrane. The roof pitch is 15°. The building had originally served as a temporary exhibition hall in Trondheim since 1984, and was not designed for the snow loads in Steinkjer.

Description of failure

On February 26th, 1995, the structure collapsed due to an error in the joint between beam and column in the outer wall. The building was completely damaged and even an annex was damaged.

Original investigation performed and conclusions

At the time of failure, the actual snow load was similar to the design snow load (1.5 kN/m²). Snow load created a tension force in the outer (glulam) column. The joint with the beam was in the lower edge of the beam and as the column transferred the tension force to the beam, tension perpendicular to grain was induced in the beam, see figure 34-1. Failure in tension perpendicular to grain occurred, leading to decreased bending moment capacity further away in the beam (at the position of the connection with the steel strut), resulting in bending failure.

The joint between column and beam should have been placed higher up in the beam to prevent splitting.

The failure is caused by insufficient design of the load-bearing structure. The execution of the connection between column and beam is not adequate.

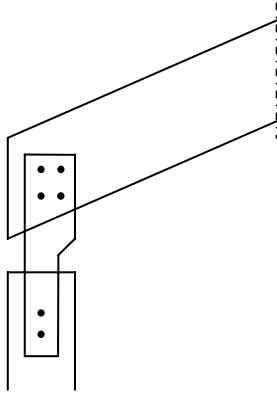

Figure 34-1. Detail of beam-column connection. After Skaug (2004).

Additional conclusions and comments

This is the same type of building as case 32. In total, 15 similar halls were produced, five of which were sold as a construction set.

Source

Eivor Skaug, 2004: Skader på moderne trekonstruksjoner i Norden (Failures of modern timber structures in the Nordic countries), Masteroppgave 2004, Fakultet for ingeniørvitenskap och teknologi, Institutt for konstruksjonsteknik, NTNU (in Norwegian), case: Steinkjer ridehall

Case 35 – Collapse of roof of tennis hall

Description of Structure

The tennis hall was built in 1990 with a length of 73 m and a width of 36 m. The load bearing structure consists of glulam beams (140 mm x 1300 mm), supported by a ridge purlin and glulam columns in the walls. The ridge purlin (190 mm x 1800 mm) itself is supported by steel columns. In line with the steel columns (18.3 m centers), double beams (2 times 90 mm x 1300 mm) were used. All load bearing elements were designed as pinned (except for lower support of the steel columns). The joints made with steel plates and bolts.

Description of failure

On March 6th, 1994, parts of the roof structure (about 350 m²) collapsed after one of the beams had failed. In total, two beams and the corresponding roof part fell down. Two more beams were so severely damaged that they were regarded as failed. The rest of the structure was slightly damaged (cracks, deformations).

Original investigation performed and conclusions

At the time of failure, a snow load of 3.5 kN/m² was present on the roof, which is equal to the design snow load in ultimate limit state (characteristic snow load on ground 2.5 kN/m² according to the code). The design contained some calculation errors, resulting in the structure being on the unsafe side.

However, the execution of the joints was not made according to the structural system. All joints had been designed as pinned; however, the ridge joint was rigid, leading to additional forces and overloading in the bolted joints.

The beams were notched at the wall support. Some lamellae were not supported and tension failure perpendicular to grain occurred. The degree of utilization for shear was 111% at the beam support.

The beam ends were connected with bolt-/bulldog-joints in several rows, which prevents shrinkage.

The glulam beams are supposed to transfer the loads at the ridge support by a combination of bolted joints and by contact pressure. However, the code was used wrongly for this type of combination. Two different kinds of fasteners can only be used if the stiffness is similar. Shrinkage created a gap between beam and support, which requires cracking in the beam before the load can be transferred by direct compression.

Thanks to the double beams with 22% higher capacity in 3 lines, the damage was limited.

Variation in material quality, execution and snow load distribution determined which beams failed. The collapse is mainly caused by wrong execution of the joint between beam and support.

Source

Eivor Skaug, 2004: Skader på moderne trekonstruksjoner i Norden (Failures of modern timber structures in the Nordic countries), Masteroppgave 2004, Fakultet for ingeniørvitenskap och teknologi, Institutt for konstruksjonsteknik, NTNU (in Norwegian), case: Asker tennishall

Case 36 – Collapse of roof in school building

Description of Structure

The school was built in 1998. The load-bearing structure consisted of glulam beams (140 mm x 800 mm) placed at 3.6 m centres. The building has a roof pitch of 22°. The secondary load-bearing structure consisted of purlins (48 mm x 198 mm) placed at 6 m centres, spanning over two bays (length 7.2 m). The principal bending plane of the purlins (strong direction) is then at an angle of 22° relative the vertical direction. The purlins are connected to the beams with sheet metal angle connectors (70 mm x 80 mm) on the downward side of the slope, see figure 36-1.

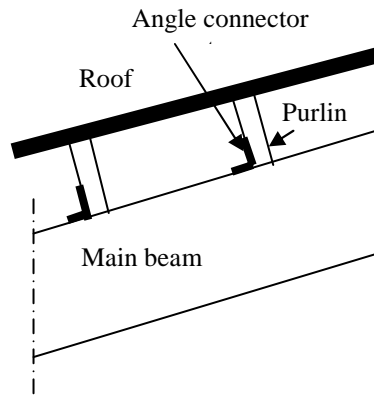

Figure 36-1. Design of purlin-beam connection

Description of failure

On Easter 2003, parts of the ceiling fell down because the purlins had rotated (65 mm from original position). The glulam beams cracked.

Original investigation performed and conclusions

At the time of failure, only little snow was present (0.6 to 0.7 kN/m², with the design load according to the code being 2.5 kN/m²). It is, however, not known, which snow load was used in the design.

The purlins were not securely fastened. The angle irons used in the connections are not appropriate for this application (according to the producer).

The failure is caused by a design error. Other fasteners should have been used to secure the inclined purlins.

Source

Eivor Skaug, 2004: Skader på moderne trekonstruksjoner i Norden (Failures of modern timber structures in the Nordic countries), Masteroppgave 2004, Fakultet for ingeniørvitenskap och teknologi, Institutt for konstruksjonsteknik, NTNU (in Norwegian), case: Emma Hjorth skole

Case 37 – Collapse of school roof

Description of Structure

The building of Storvoll School was changed in 1990. The old roof sloped towards the middle of the building. In 1990, wall studs (2.4 m centres), were attached to the ground and the old wall structure. The studs carry a glulam beam that serves as a support for trusses of a pitched roof above the old roof. In the middle of the building, the trusses are supported by a length-wise column-beam system. Due to transport restrictions, the trusses were produced in two halves, which were connected to each other and to the supporting beam with steel strips. The trusses were placed at 0.6 m centres.

Description of failure

On February 29th, 2000, the new roof collapsed and fell onto the old roof below. The middle beam (supported by columns in the middle of the building) had moved towards the gable and had penetrated the gable wall. The lower edges of several trusses moved along with the beam and the ridge moved downwards.

Large parts of the roof covering were damaged. Walls were askew and the gable wall was severely damaged. The old roof was more or less intact.

Original investigation performed and conclusions

The investigation revealed that the snow load at the time of failure (4.34 kN/m^2) resulted in a degree of utilization of the roof structure of 97% if compared to the design load according to code. However, it is not known which snow load the structure was designed for.

The bracing and connections were insufficient and erroneous. No connection was present between the middle beam and the old roof. The middle beam was connected to the columns with only three nails. No diagonal bracing was present in the ridge direction of the building. The beam-column system in the middle without bracing became unstable under snow load.

The building was loaded with the highest snow load ever measured in the area.

Source

Eivor Skaug, 2004: Skader på moderne trekonstruksjoner i Norden (Failures of modern timber structures in the Nordic countries), Masteroppgave 2004, Fakultet for ingeniørvitenskap och teknologi, Institutt for konstruksjonsteknik, NTNU (in Norwegian), case: Storvoll skole

Case 38 – Lifting of flat roof

Description of Structure

The school building timber was built in 1963 with a more or less flat roof, with purlins placed at 3.8 m centres on main beams and walls respectively

Description of failure

In October 1996, about 350 m² of the roof was blown away on the windward side during a storm.

Original investigation performed and conclusions

The purlins had been fastened with steel strips using one nail per joint and with some sheet metal angle connectors.

The collapse occurred due to insufficient anchorage against wind.

Additional conclusions and comments

However, it could not be found out whether this is a design error or an execution error. Therefore, the failure is classified as “unknown failure cause”.

Source

Eivor Skaug, 2004: Skader på moderne trekonstruksjoner i Norden (Failures of modern timber structures in the Nordic countries), Masteroppgave 2004, Fakultet for ingeniørvitenskap och teknologi, Institutt for konstruksjonsteknik, NTNU (in Norwegian), case: Svartholt skole

Case 39 – Partial collapse of school roof

Description of Structure

The school building in Lillehammer was finished in 1972 with a length of 48 m, width of 16.8 m and a height of 5.25 m. The load-bearing structure consists of roof trusses of W-type with punched metal plates and a roof pitch of 15°.

Description of failure

On April 1st, 1988, parts of the roof collapsed: Four bays in the northern end of the building collapsed.

Original investigation performed and conclusions

The investigation showed that the diagonals of the trusses were poorly designed (too low capacity). Very likely, the failure started in the mostly stressed diagonals, leading to progressive failure after load redistribution.

The trusses have been designed for a snow load of 1.5 kN/m², however, the characteristic value in the code is 2 kN/m². The actual snow load was between 0.85 kN/m² (near the eaves) and 2.25 kN/m² (near the ridge). With several calculation models and the actual snow loads, compression forces between 5.9 kN and 16.3 kN were calculated for the diagonals, the capacity of which was only 3.3 kN.

Furthermore, some errors were found in construction details:

1. The anchorage of the trusses to the walls with only two nails was not sufficient.
2. Bracing was nailed to the upper rafters with two rows of nails. However, due to too small distances between the nails and between nails and edges, splitting occurred.

The main cause of failure is poor design of the diagonals in the roof trusses.

Source

Eivor Skaug, 2004: Skader på moderne trekonstruksjoner i Norden (Failures of modern timber structures in the Nordic countries), Masteroppgave 2004, Fakultet for ingeniørvitenskap och teknologi, Institutt for konstruksjonsteknik, NTNU (in Norwegian), case: Nybu skole

Case 40 – Collapse of agricultural building

Description of Structure

An agricultural storage building was erected in 1997 with a length of 120 m and a span of 21.5 m, using roof trusses of W-type with punched metal plate fasteners. The roof pitch is 15°.

Description of failure

During the construction, when only the trusses and the bracings were in place, large parts of the building collapsed.

Original investigation performed and conclusions

At the time of failure, the structure was only loaded with dead load and some wind load. The span of the trusses was larger than usual, therefore they were very weak in the out-of-plane direction.

Several mistakes were done during the construction:

1. The trusses were lifted by crane with a single-point lift (instead of two point lift).
2. It was not checked whether the building was vertical.
3. Roofing tiles (2 packages à 1.3 ton) were placed near the eaves, resting on only 2 trusses
4. No marks were made on the trusses for where to fasten the bracing.
5. Bracing in walls and roof was fastened with one nail (recommended: 3 nails).
6. The present bracing would not even be sufficient in a single-family-house.
7. No engineering design was done, forces in the roof resulting from wind and inclinations were not considered.
8. Insufficient temporary bracing in walls and roof.

The investigation revealed that the bracing had been poorly designed. The trusses were inclined, bracing was insufficient and a wrong structural system was used.

Source

Eivor Skaug, 2004: Skader på moderne trekonstruksjoner i Norden (Failures of modern timber structures in the Nordic countries), Masteroppgave 2004, Fakultet for ingeniørvitenskap och teknologi, Institutt for konstruksjonsteknik, NTNU (in Norwegian), case: Wadvedt landbruk

Case 41 – Collapse of trusses in sports arena

Description of Structure

The roof structure of the cycle velodrome is a fish-shaped truss with double upper and lower rafters and single verticals (placed at 6.4 m centres), but no diagonals, built in 2001, see figure 41-1. The trusses span 72 m and are supported by concrete columns. One of the supports allows horizontal movements in the trusses direction. The verticals are connected to the rafters with two bolts including bulldog. The upper rafter has dimensions 2 times 160 mm x 900 mm (with 160 mm gap), the lower rafter has dimensions 2 times 160 mm x 533 mm (with 160 mm gap), and verticals are 160 mm x 160 mm (in between the rafters). The upper rafter is braced by purlins (220 mm x 440 mm) placed at 6.4 m centres (as the verticals). Diagonal bracing is also provided in the roof plane. The lower rafter is braced by boards (160 mm x 200 mm), placed at 12.8 m centres.

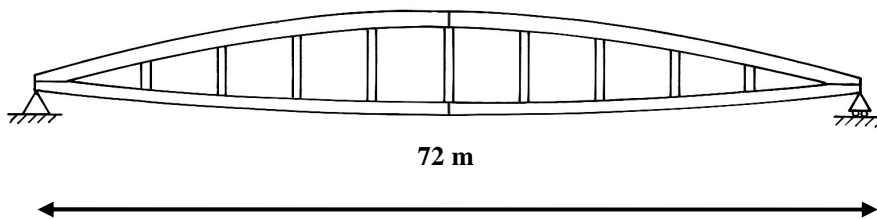

Figure 41-1. Design of glulam truss.

Description of failure

On January 4th, 2003, two out of twelve trusses collapsed, see Figure 2 in main text. During the failure, the weather was wind still and there was no snow load on the roof.

Truss no. 4 collapsed first. Due to load redistribution, trusses no. 3 and 5 were overloaded. Truss 3 then collapsed similar to the previous collapse, whereas truss 5 managed to withstand.

Original investigation performed and conclusions

The investigation revealed the following mistakes in the design:

1. A too high value for tensile strength (18.7 MPa instead of 12.6 MPa) was used in the calculations, overestimating the strength by 48 %.
2. The cross-sections used in the calculations are the nominal cross sections; however, at the heel joint, the cross-sections are reduced to be able to connect upper and lower rafters (inclined sawing). The cross-section was overestimated by 25 %.

3. The cross-section is not reduced (net cross-section) for bolt holes and slotted-in steel plates. Those reduction lead to an overestimation of cross-section in the lower rafter of about 30 %.
4. Due to the inclined sawing in the heel joint, the normal force (centric at midspan) was eccentric (eccentricity about 50 mm), resulting in eccentricity-moment, which was not considered in the design calculations.
5. The number of dowels and slotted-in steel plates result in a stiff joint, creating an additional moment, which was not considered in the design.
6. The design of the dowel joint was not correct, using uniform load distribution across all dowels. However, a more thorough calculation shows that individual dowels could be loaded with 30 kN (plastic calculation) to 40 kN (elastic calculation). The capacity is, however, only 20 kN. This results in an overestimation of the dowels capacity of 50 to 100 %.
7. Inclined sawing results in an angle between fibre direction and the edge, which reduces tension and bending moment capacity.

All these factors named above implies that the capacity of the first dowel row in the lower rafter is only 25% to 30% of the required capacity. At the same time, the load effect was about 30 to 40% higher than the characteristic strength (with reductions due to duration of load effect). Tension failure in the lower rafter at the position of the first dowel row initiated the collapse.

Other factors that could have caused or contributed to the failure were also investigated. Among other things, stability of the high trusses, drying, creep, overloading during construction or use, size factors, interaction of effects of slots and dowels and importance of blocks glued between the rafters at the heel joint were investigated. However, those factors did not contribute significantly to the failure.

This failure is caused by multiple errors in design.

Additional conclusions and comments

Pictures from this case can also be found in the main text, see Figures 2 and 21.

Source

Thorup, P.M., Larsen, H.J.: Skønserklæring, Ballerup Superarena, Syn & Skøn – Jour. Nr. A 5102 ved Voldgiftsnævnet for Bygge- og Anlægsvirksomhed, 4.3.2003. (in Danish)

Case 42 – Large cracks in hollow section

Description of Structure

The football hall was built in 1991 with a span of 100 m and a length of 132 m. The structural system consists of two-hinged arches with a span of about 89 m and apex height of 17.5 m. The arches are composed of glulam beams, forming a hollow section with total width of 495 mm and total height of 1800 mm. Each web is 140 mm thick and the flanges are 180 mm thick. Each arch consists of four straight parts, which are connected to each other with nailed steel plates at the apex and quarter points of the arches.

Description of failure

During winter 1993-94, large cracks, about 200 mm wide and more than 10 m long occurred in the apex splice close to the steel plates.

Original investigation performed and conclusions

At the time of failure, unsymmetrical snow load (ranging from 0.83 kN/m² to 5.5 kN/m²) was present on the roof. This non-symmetrical load induced shear forces in the apex joint that could not be transferred by the kind of joint used. The roof had been designed for uniform snow load of 3.75 kN/m².

The main reason for failure was wrong design of the joints. Steel plates with dowel-type fasteners on the flanges and on the webs could not transfer the loads without splitting. This kind of joint would probably work in a steel structure. See also Figure 3 in main text.

Additional conclusions and comments

The Swedish code was changed after this failure to include non-symmetrical snow load.

Source

Eivor Skaug, 2004: Skader på moderne trekonstruksjoner i Norden (Failures of modern timber structures in the Nordic countries), Masteroppgave 2004, Fakultet for ingeniørvitenskap och teknologi, Institutt for konstruksjonsteknik, NTNU (in norwegian) and

Olsson, N., 2001: Glulam Timber Arches – strength of splices and reliability-based optimisation, Doctoral Thesis, Department of Civil and Mining Engineering, Division of Timber Structures, Luleå University of Technology, Report 2001:12.

Case 43 – Collapse of glulam beam in swimming hall

Description of Structure

The almost flat roof of a swimming hall is built up with several glulam beams, which are supported by a concrete wall on one end and by concrete columns on the other end. The wall support was designed as a fork support. Lateral bracing with wooden diagonals is provided at the upper edges of the beams. A 65 mm layer of substrate is placed on the roof surface to facilitate growth of vegetation (green roof).

Description of failure

After 22 years of use, one beam failed in bending, leading to a partial collapse of the roof.

Original investigation performed and conclusions

The failure is caused by a combination of design and erection errors. Eccentricity in the connection between wall and beam caused rotation of the supporting steel parts, leading to a gap between glulam and steel, decreasing the load-transferring area and therefore increasing compression perpendicular to grain. Furthermore, the fork support was designed but not installed. This and inaccuracies during construction as well as the increased compression perpendicular to grain caused a rotation of the beam around its main axis. Due to the rotation, the effective moment of inertia was reduced, leading to increased deflection.

The low slope of the roof and the creep deformation caused the water in the substrate to move towards the deflected beam, increasing the loads and therefore the deflection additionally.

In design of the bracing, the loads were underestimated, leading to joints with too low capacity. The joints could not take up the horizontal forces, giving rise to additional lateral deformation, increasing the rotation of the beam. Due to the decreasing moment of inertia during rotation, deflection increased until the beam failed in bending.

Two design errors (bracing, compression perpendicular to grain) and one construction error (no fork support) caused the collapse.

Source

“Teileinsturz einer Schwimmhalle”, mikado 3/2003, WEKA MEDIA GmbH & Co KG, ISSN 0944-5749

Case 44 – Collapse of nailed truss

Description of Structure

A 28 m long production hall was designed with nailed trusses with 21 m span. It was later reused as a retail building, with installation of new ceiling and ventilation.

Description of failure

Twenty-eight years after inauguration, 7 out of 17 trusses failed. The trusses failed next to an assembly joint in the upper rafter. In all trusses, a sinusoidal lateral deformation of the upper rafter was noticed after failure.

Original investigation performed and conclusions

The extra dead loads from new ceiling and ventilation were determined, being lower than the design load. Therefore, the failure could not be attributed to overloading.

According to the design, joints between purlins and rafters should be carried out with four nails. However, only one nail was found per joint. Furthermore, no nail at all was installed in some places due presence of knots. A calculation showed that for dead load only, joints with only one nail would theoretically fail. In some places, even four nails would not be sufficient.

The failure was initiated in a section with maximum compressive compression in the upper chord and where the lateral stiffness of this chord was low. Stability is not sufficient in this section (when calculated with four-nail-joint).

Additional conclusions and comments

There are a lot of similar constructions in former eastern Germany, which should be investigated for stability when still used or re-used.

Source

“Einsturz eines Hallendaches mit genagelten Holzfachwerkbindern nach 28 Jahren Standzeit”, Dipl.-Ing. Jörn Konow, Ingenieurbüro Prof. Krüger & Partner, 23968 Wismar; downloaded from

http://dls01.vogel-medien.de/vmg/baumedien/download/339987/2005_02_14_Einsturz_eines_Hallendaches_mit_genagelten_Holzfachwerkbindern.pdf

Case 45 – Collapse of roof in skating hall

Description of Structure

A skating hall was built in 1971/72 with a length of 75m and a width of 48m. The roof structure consists of 2.87m high box girders, see figure 45-1. The box girder consists of 200x200mm² glulam in the upper and lower flanges and special webs, consisting of 3 layers of boards, with the boards in the two outer layers oriented parallel with the beams axis and the middle layer being rotated 15° against the beams axis. Both flanges and webs were jointed with finger joints (the flanges consisted of 3 beams with 16 m length each). The structural system is a simply supported beam with 40m span cantilevering 4m beyond both supports. Lateral bracing was provided by purlins (120mm x 460mm) every 3.17m, and trusses for wind bracing in the roof plane.

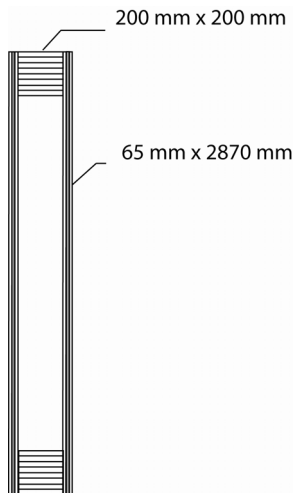

Figure 45-1: Box girders used in roof structure.

Description of failure

On January 2nd, 2006, the roof of the skating hall collapsed after heavy snowfall. Fifteen people were killed, 35 injured. First, one beam failed, but due to the stiff connections (bracing), the neighbouring beams were overloaded and failed (domino effect).

Original investigation performed and conclusions

The investigation of failure was conducted by Prof. Winter and Prof. Kreuzinger (both Technical University of Munich) and Anton Ruile (Technical Inspection Authority, Munich). They found the failure to be due to the following causes:

1. For the special type of beams described above, there was only a national technical approval (from German centre of competence in civil engineering DIBt) regarding a depth up to 1200mm, but beams with depth 2870mm were used in this structure. An application to expand the approval to larger beam sizes was not approved.
2. The structural designs were not checked by a third party engineer. The structural design contained two significant mistakes/flaws: Tension stress in the centroid of the flanges was not checked, overestimating the load-carrying capacity of the flanges. Moreover, cross-section reduction in the finger-joints was not considered, leading to an overestimation of load-carrying capacity. Safety margin was thus only 1.5 (instead of 2.0 which was demanded in the German building code).
3. The beams were produced using a urea-formaldehyde-resin. Also at the time of construction, this type of resin was only allowed in dry conditions (climate), which is not found in a skating hall. With today's knowledge, urea resins are not durable in moist climate. In the thick glue lines between flanges and webs, resorcinol resin (more elastic) should have been used instead. The moist climate had during the years degraded the glue lines. For example, in the finger joints of the lower flanges, there was no bond effect down to a depth of 5-8cm. Moisture damage of the glue lines is regarded as one of the fundamental reasons for the failure.
4. The production of the beams did not follow the state-of-the-art technology. The production of finger-joints in the webs is regarded as difficult and not robust. The quality of glue lines was very varying. Those flaws are fundamental reasons for the failure of the structure.
5. During the use of the building, water leakage in the roof was a common problem, but the leakages were not permanently fixed. Moreover, the timber structure was not painted. Whether those measures could have postponed the failure, is not sure. Furthermore, there is no documentation on inspections of structural safety. During an inspection, a professional could have detected problems with the finger joints and glue lines between flanges and webs and initiated necessary measures.

Summarizing, the reasons for failure are the following: mistakes in structural design, poor principles during production of the beams, and not satisfying durability of the glued connections.

Additional conclusions and comments

A procedure was opened against 8 people regarded responsible for the deaths that occurred. Four of them were formerly working in the community, two were working in the companies that built the roof structure, and the other two were architects /civil engineers, being responsible for the erection / inspection of the building.

Source

Regarding structure: Holzbauatlas 1978, page 84.

Regarding failure and failure reasons: Presseerklärung der Staatsanwaltschaft Traunstein zum Einsturz der Eishalle in Bad Reichenhall, Der Leitende Oberstaatsanwalt in Traunstein, 2006-07-20

Case 46 – Collapse of cantilever beam system

Description of Structure

A warehouse was built in 1965 with a glulam framed cantilevered roof. The beams were simply supported with two spans with 70 ft length each and with 16 ft overhangs (cantilevers) on both sides. The building was notched on the corners, i.e. there was no overhang at the corners of the building.

Description of failure

A portion of the roof (first beam inside the building) collapsed after a heavy rainstorm.

Original investigation performed and conclusions

Due to the notching at the corners of the building, the first beams only carried 50% of the load on the cantilevers compared to beams inside the building. This resulted in higher bending moments in the inner long spans of the beams, for which they were not designed – beams were only designed for balanced loading. Bracing was inadequate in the negative bending moment region, but did not contribute to the collapse.

Additional conclusions and comments

The beams were not designed for the worst load case.

Source

Ratay, R. 2000: Forensic Structural Engineering Handbook, McGraw-Hill: Case study 1. Port of Longview Warehouse No.1, Longview, Washington.

Case 47 – Collapse of roof under construction

Description of Structure

A wood framed one-storey building was under construction 1977. Trusses 42 inch deep with spacings of 32 inches were used over a span of 68 foot.

Description of failure

Some of the trusses collapsed during the construction, some remained standing, see Figure 16 in main text. .

Original investigation performed and conclusions

The investigation of the failed trusses showed chord buckling and truss rollover. The bracing (bridging, plywood shear panels) had not been installed yet when the failure occurred. To save money (crane time), all trusses were installed first, before the bracing was done.

Source

Ratay, R. 2000: Forensic Structural Engineering Handbook, McGraw-Hill: Case study 2: McMinnville Town Center, McMinnville, Oregon.

Case 48 – Buckling of trusses

Description of Structure

Two hangars were built with length 317 m, width (span) 90 m with two-hinged arch trusses. Trusses are constructed with double chords, double diagonal webs and single vertical webs, the arch rising to a height of 52 m.

Description of failure

A forensic investigation showed 36 buckled chords.

Original investigation performed and conclusions

A forensic investigation showed 36 buckled chords. The reason for buckling was wrong length to thickness ratio in the design. The 76 mm wide chords buckled, whereas 100 mm wide chords in otherwise similar structures functioned well.

Additional conclusions and comments

Repair was carried out with glulam blocks placed between the double chords and glulam beams aligned on the sides of the chords to realign them.

Source

Ratay, R. 2000: Forensic Structural Engineering Handbook, McGraw-Hill:
Case Study 3: Lighter than Air Hangars, Moffett Field Naval Air Station, Moffett Field, California.

Case 49 – Splitting of glulam member

Description of Structure

A library roof spanning 14 m was built with parallel chord trusses (depth 1,5 m) made of glulam, with connections consisting of bolts and steel plates. The design model used continuous chords and pinned web-to-chord joints.

Description of failure

About 5 years after completed erection, one diagonal web member split during snow loading.

Original investigation performed and conclusions

The investigation showed that the joints between web and chords were moment stiff, and not pinned. The joint length (from chord mid to outer bolt) in the failed web was 71 mm, creating a moment couple, which induced perpendicular to grain tension when the joint rotated due to truss deflection under load.

Additional conclusions and comments

The web was replaced. In the joint, stitching bolts were installed to resist perpendicular to grain forces.

Source

Ratay, R. 2000: Forensic Structural Engineering Handbook, McGraw-Hill: Case Study 6: Rainier Beach Library, Seattle, Washington.

Case 50 – Failure of purlins due to drifting snow

Description of Structure

A side building with 18 m length was attached to a primary warehouse building, which was 3.4 m higher than the side building.

Description of failure

During winter 1994/95 (7 years after completion of the building), wind-driven snow accumulated on the lower building, as the higher building acted as a snow fence. Workers could walk on the snow from the roof of one building to the roof of the other building. The loading led to fracture of one purlin and several subpurlins.

Original investigation performed and conclusions

The building was not designed for snow drift, but only for uniform snow load.

Source

Ratay, R. 2000: Forensic Structural Engineering Handbook, McGraw-Hill: Case Study 12: Albertsons Grocery Warehouse, Portland, Oregon.

Case 51 – Deflection of timber beams

Description of Structure

A roof structure above a swimming pool was constructed of 12 m long glulam beams (distance 4m) and laminated purlins. The beams were produced in 1992, but due to political and economical changes in the country, the structure was not assembled until 1997.

Description of failure

After three years of performance, the glulam beams experienced excessive deflection in December 2000. No snow load was present on the roof, and the outside temperature was about +12°C. The pool was closed and the beams were supported with steel columns.

Original investigation performed and conclusions

On the glulam beams, painted in brown colour, cracks between lamellae could be seen. The lower lamellae were separated from two beams. Furthermore, shear cracks at the support were found.

Investigation of the gluing diary showed that very different gluing times (between 3 and 72 hours) were used. On the beams, it could be observed that the glue was concentrated at certain places, but no uniform glue line was provided.

Additional conclusions and comments

A supporting steel structure was fixed to the sides of the glulam beams.

Source

Vasek, M. 2006: Some problems of timber structures solved by forensic control, in: Proceedings of World Conference on Timber Engineering 2006, Portland, USA.

Case 52 – Failure of a slab due to high spiral grain

Description of Structure

A slab in an apartment building was built with a primary structure of timber of dimensions 160 mm x 180 mm and a secondary structure on top, consisting of tongue and groove boards.

Description of failure

After inauguration, the beams started to crack, and after about 1.5 years of use, 2 beams failed.

Original investigation performed and conclusions

The investigation of the beams' quality showed that the spiral grain angle was higher than allowed in the German code for the grading class to be used in load-bearing structure. Due to the spiral grain angle, the load bearing capacity was reduced. The beams must have been built-in with high moisture content and dried significantly, resulting in large cracks.

The failure is due to wood quality and on-site alterations.

Additional conclusions and comments

The failure could have been avoided if dry timber had been used. Timber beams with that high spiral grain angle would have twisted during drying and the carpenter would have rejected them.

Source

Colling, 2000: Lernen aus Schäden im Holzbau, Teil B: Typische Beispiele. Deutsche Gesellschaft für Holzforschung e.V., ISBN 3-934915-00-0, Schadensbeispiel 2-02

Case 53 – Deformations in dowel-type joint

Description of Structure

In a roof construction three beams were connected in one point (the mutual angles between the three members were 135°, 112.5° and 112.5°) with a slotted-in steel part. The joints had been designed with 2 and 4 dowels (8mm diameter) respectively.

Description of failure

Relative displacements in some of the joints up to 20 mm were observed, leading to gaps in the joint and the sheathing.

Original investigation performed and conclusions

An investigation revealed that too few dowels had been used in the joints.

This case is caused by on-site alterations. It is assumed that problems during erection of this complicated joint led to the error.

Source

Colling, 2000: Lernen aus Schäden im Holzbau, Teil B: Typische Beispiele. Deutsche Gesellschaft für Holzforschung e.V., ISBN 3-934915-00-0, Schadensbeispiel 3-07

Case 54 – Cracks in truss

Description of Structure

The music hall of a school is roofed with visible trusses 2.2 m on centre. The joints are carried out with one slotted-in steel plate and 10 mm dowels in three rows.

Description of failure

Large cracks and gaps between diagonals and chords were observed. In one joint, a crack following the middle dowel row had a depth of half the beam depth (i.e. to the slotted-in steel plate). In the other dowel rows, smaller cracks were observed. Some of the joints are mechanically damaged on the outside. It was feared that the load-bearing capacity of the joints was not satisfactory.

Original investigation performed and conclusions

Some of the cracks were caused by drying. It is assumed that the timber used had a high moisture content (but below 30%), which leads to drying cracks and reduction of the length of the members and therefore to gaps between members. However, drying cracks are considered in the building code and do not result in reduction of load-bearing capacity compared to the design.

The mechanical damage on the outside of the joint is caused by non-professional execution of the dowel-type joints. Some dowels were even placed next to the prepared holes. The non-professional execution caused extra cracks / splitting. The deep crack in the middle dowel row implies that the dowels in this row do not take any load. Due to more cracks / splitting, the load-bearing capacity of the remaining two dowel rows is reduced, leading to inferior load bearing capacity.

This failure is caused by poor principles during erection.

Source

Colling, 2000: Lernen aus Schäden im Holzbau, Teil B: Typische Beispiele. Deutsche Gesellschaft für Holzforschung e.V., ISBN 3-934915-00-0, Schadensbeispiel 3-08

Case 55– Deflection in suspension structure

Description of Structure

A structure with 6.5 m span is suspended from the roof in the living room of a traditional Bavarian house.

Description of failure

After completion, large deflections (30 mm) in the lower chord (tension chord) were observed.

Original investigation performed and conclusions

The deflection pointed at an unscheduled bending loading in the tension chord. The investigation revealed a wrong structural system. The joints between compressed struts and tension chord are performed as scarf joints (traditional carpentry joints). The joints have lower load bearing capacity than needed to transfer the compression force of about 63kN. Instead of a half scarf joint, a double scarf joint would have been adequate. Overloading in the joint led to load redistribution, giving the vertical, which should be unloaded, a compression force, which is transferred into the lower chord. This creates a bending moment in the lower chord, which was designed as a tension chord. Furthermore, on the other side of the truss, the joint is eccentric, as it is placed about 400 mm before the support of the suspension structure. This leads to additional bending in the tension chord, increasing the deflection to 30 mm.

This failure was caused by wrong design for mechanical loading.

Additional conclusions and comments

The structure had to be reinforced by parallel trusses in level with the lower chord.

Source

Colling, 2000: Lernen aus Schäden im Holzbau, Teil B: Typische Beispiele. Deutsche Gesellschaft für Holzforschung e.V., ISBN 3-934915-00-0, Schadensbeispiel 3-10

Case 56– Change of roof structure causes distortion of exterior walls

Description of Structure

Log house.

Description of failure

The exterior walls of a log house leaned outwards, starting directly after completion of the building.

Original investigation performed and conclusions

Inclined exterior walls indicate problems with horizontal forces from the roof structure. The investigation showed that the roof structure of the log house was executed differently from the design. The design was made for a roof with collar beam, where the beams in the slab between ground floor and first floor should serve as tie beams, see figure 56-1 (left). However, the roof structure was executed with intermediate purlins above the collar beam that were not in contact with the rafters and thus not statically used at all. However, notches had been prepared, which weaken the cross-section (about 30% reduction) and load-bearing capacity of the rafter. The rafter dimensions were smaller than in the design. The smaller dimensions and notches imply that the stresses exceed the design stresses by 25%. Furthermore, due to the long span in the ground floor (living room), two binding beams are used and the tie beams were jointed with the binding beams via sheet metal joist hangers. However, the joist hangers were not properly nailed to neither binding beams or tie beams and were only supposed to transfer vertical loads. Horizontal loads cannot be transferred here, but have to be taken in the joint between rafters and exterior walls. This led to an outward compression on the exterior walls. Additionally, the tie beams were drawn out of the bag of joists (about 5 cm). Due to risk of collapse of the whole construction, the residents were evacuated and the structure had to be changed. The failure in this case was due to changes on the building site, compared to the design (on-site alterations).

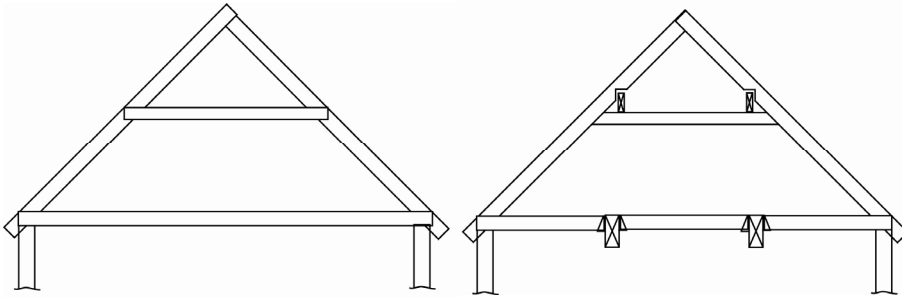

Figure 56-1: Designed roof structure (left) and executed roof structure (right).

Source

Colling, 2000: Lernen aus Schäden im Holzbau, Teil B: Typische Beispiele. Deutsche Gesellschaft für Holzforschung e.V., ISBN 3-934915-00-0, Schadensbeispiel 3-11

Case 57 – Deflection of roof structure in a log house

Description of Structure

Log house.

Description of failure

After completion, large deflections were observed in intermediate and ridge beams as well as in one binding beam.

Original investigation performed and conclusions

The investigation showed that there was no real ridge beam, but its function was performed by a central log wall and partly by six log beams (120 x 140 mm²) placed on top of each other over a large opening in the central wall. The six log beams are not connected to each other. The “ridge” beam is not joined above a transversal wall and is thus not continuous. The intermediate beams consist of two log beams (110 x 170 mm²) without connections. The binding beam consists of three beams (120 x 140 mm²) upon each other.

The structural design of the ridge beam was made for three log beams upon each other, connected every 70cm with bolts. In the design calculations, the load-bearing capacity was calculated for a solid cross-section with 360 x 120 mm². The bolted cross-section has lower load-bearing capacity than a solid cross-section (only sum of single cross-section moment of inertia). Furthermore, since no bolts were installed in the beams the problem will become even worse. This results in large deflections (53 mm instead of allowed 21 mm) and too high stresses. The same problems are valid for the intermediate beams and the binding beam. The binding beam has a deflection of 80 mm (allowed 13.3 mm).

The failure in this case was caused by a combination of design error in mechanical design (composite cross-section calculated as solid cross-section) and on-site alterations (no bolt connections in the composite cross-section).

Source

Colling, 2000: Lernen aus Schäden im Holzbau, Teil B: Typische Beispiele. Deutsche Gesellschaft für Holzforschung e.V., ISBN 3-934915-00-0, Schadensbeispiel 4-04

Case 58 – Wrong structural system in log house

Description of Structure

One-family log house.

Description of failure

In a log house, the interior walls buckled under the load of the intermediate beams.

Original investigation performed and conclusions

The investigation showed that the log house that was delivered as a construction set was a mixture between log house and timber frame building. The structural design assumed a timber skeleton that transfers all vertical loads. No provisions were made to transfer the horizontal loads. The result was that horizontal forces had to be taken up by the longitudinal log walls.

A combined system of timber frame and log house does not work. Shrinkage was not considered in the design, resulting in differential shrinkage between timber frame walls and log walls, creating gaps between floors and walls.

The rafters were fixed on the intermediate beams / walls which prevents movement that is needed in a shrinking log house. The intermediate beams were overloaded by 40%. They rested on interior walls that were also overloaded and buckled.

Gable walls, roof structure and beams in the slab were neither according to the structural design nor the assembly plan.

This failure was caused by a combination of design error (both mechanical and environmental (shrinkage)) and on-site alterations.

Source

Colling, 2000: Lernen aus Schäden im Holzbau, Teil B: Typische Beispiele. Deutsche Gesellschaft für Holzforschung e.V., ISBN 3-934915-00-0, Schadensbeispiel 4-05

Case 59 – Cracks in glulam beams

Description of Structure

A tennis hall is roofed with three-hinged arched glulam beams (width 140 mm). The beams are connected at the ridge with slotted-in steel plates with dowels, steel plates on both sides (bolts) and a hinge in between.

Description of failure

Cracks were observed in the structure. Cracks were found all over the beams and especially in the region of the ridge joint. Most of the cracks were not too deep, however, some of the cracks at the joint were in the dowel line and some were deep (up to half of beam width).

Original investigation performed and conclusions

The cracks in the beams were caused by drying (shrinkage) and do not reduce the load-bearing capacity of the beams (degree of utilization for stress = 44%). The cracks at the joint were caused by restrained shrinkage (slotted-in steel plates, four dowel rows). The shear capacity is reduced and tension stresses perpendicular to the grain develop.

The failure in this case was caused by disregard of environmental actions (shrinkage) in the design.

Additional conclusions and comments

The cracks were filled with epoxy-glue. Shear forces and tension forces perpendicular to grain at the ridge joint have to be transferred by glued-in steel rods or glued reinforcement on the sides of the beams.

Source

Colling, 2000: Lernen aus Schäden im Holzbau, Teil B: Typische Beispiele. Deutsche Gesellschaft für Holzforschung e.V., ISBN 3-934915-00-0, Schadensbeispiel 4-07

Case 60 – Decay in glulam beams

Description of Structure

An octagonal church room is roofed by glulam beams (spanning 36 m) that are oriented from the centre of the room outwards (star-formed). The beams are supported by the outer walls and are rigidly connected in a steel joint in the middle. The flat roof is placed at a height of about 1/3 of the beam depth (1.7m) above the lower edge of the beams. This means that the largest parts of the beams are exposed to weathering. Horizontal faces are covered with boards (5 mm air gap). The beams' surface is treated with a glaze that is effective against fungi, insects, and weathering and is possible to paint.

Description of failure

After about 5 years, the glulam beams showed cracks of varying depth on the sides. The painting had disappeared. Furthermore, the lower edges of the cover boards and the upper edges of the glulam beams are moist.

Original investigation performed and conclusions

The investigation showed that the beams had been infested with fungi.

Both the chemical wood preservation and wood preservation by design were insufficient for these very exposed beams. The cover boards had too small excess length (only about 1 cm) and were not tight. Cover boards were placed vertically on the endgrain, however, penetration of water could not be prevented.

The glazing could only protect the timber for about a year, then it had been degraded so much that the beams were not protected any more. Weathering cracks and cracks caused by residual stresses arose and took up water. The high moisture content provides a good environment for fungi.

The failure in this case is caused by disregard of environmental actions.

Additional conclusions and comments

There is risk for reduced load-bearing capacity of the timber beams. Therefore, a new load-bearing structure is proposed. Timber parts should be impregnated and kept dry.

Source

Colling, 2000: Lernen aus Schäden im Holzbau, Teil B: Typische Beispiele. Deutsche Gesellschaft für Holzforschung e.V., ISBN 3-934915-00-0, Schadensbeispiel 6-06

Case 61 – Collapse of nailed roof trusses

Description of Structure

A warehouse was built with massive masonry walls and nailed timber trusses (1.15 m on centre) in 1965. The roof decking consisted of fibre-cement panels. In the gable walls, large openings were secured by concrete tie beams.

Description of failure

In January 2002, the roof failed. The upper chords of the trusses buckled (horizontal deflection about 200 mm) under a snow load of about 40 cm. The height of the truss at that position was about 1.33 m. In some trusses, buckling led to failure of the timber.

Original investigation performed and conclusions

The investigation showed that the bracing system present was insufficient. In the roof plane, wind bracing with diagonals of timber (3 cm x 14 cm) was present in two fields 10 m apart. In addition, the drawing contained five vertical bracings. The roof structure contained bracings at four vertical studs of the trusses. However, horizontal bracings at the level of the upper chord were not present. Those bracings are needed to transfer the horizontal loads to the walls / supports.

The purlins and the sheathing present were not considered as bracing in the design. However, they provide some degree of stability. It was supposed that this bracing is not sufficient for the design snow load and it was concluded that during the almost 40 years of use, no high snow loads near the design load had occurred. However, the load level at failure was still lower than the design load.

This failure is due to on-site alterations, disregard of the design.

Additional conclusions and comments

External control on the building site could have prevented this failure.

Source

Gerold, M., Becker, H.: Einsturzursache Schnee- oder Eislast? Oder fehlende Bauüberwachung? – Teil 1. in: Der Bausachverständige, 2 (2006): 21-24.

Case 62 – Collapse of nailed roof trusses

Description of Structure

A self-storage warehouse (45.7 m x 15.2 m) was to be built using nailed roof trusses.

Description of failure

During construction, each truss was lifted by crane and connected to the previous truss (2 ft distance) with spacers (1 in x 2 in with 2 ft length), using 2 inch long nails in five positions on the truss. No other lateral support was provided. When working on one of the last trusses, the workers heard a snap and saw that the centre truss collapsed. The other trusses collapsed in a domino fashion. Luckily, the workers managed to get out of the way. Some trusses that did not collapse exhibited a clear “S” shape.

Original investigation performed and conclusions

This collapse was caused by inadequate temporary bracing. Use of 3.5 inch nails had been recommended, but 2 inch nails had been used. Furthermore, they were not fully driven to simplify removal by the roofer.

Two weeks later, a second collapse occurred. The contractor had used some of the old (collapsed) trusses and rebuilt the roof, this time with better bracing. However, the temporary bracing could not withstand wind of 48-64 km/h and the whole roof collapsed again.

Both failures are caused by inadequate bracing.

Additional conclusions and comments

The designer should design the bracing and should not leave it to the builder despite the fact that there are handbooks available. However, those are more or less unknown.

Source

Kagan, H.A., 1993: Common causes of collapse of metal-plate-connected wood roof trusses. In: *Journal of Performance of Constructed Facilities*, Vol. 7, No. 4, pages: 225-234 (case 1).

Case 63 – Collapse of nailed roof trusses

Description of Structure

A shopping centre was built with concrete walls and a wood truss roof system. A steel beam supported by steel columns ran along the axis of the building, supporting the trusses and thus reducing the span from 22 m to 11 m. Two monopitch trusses spanning from wall to steel beam were used. They were not inter-connected at the beam support but acted as two independent halves.

Description of failure

After six years in service, half of the roof collapsed after two days of snow and rain. The snow depth was 0.64 m on the ground.

Original investigation performed and conclusions

The inspection revealed that the bracing was inadequate. The only lateral bracing present was on the vertical at the beam support. However, all other verticals and diagonals were unbraced. The bow shape of diagonals could be seen in the intact half of the roof. Spacers (temporary bracing, 2 ft long) were still in place at the bottom chord.

The very long diagonals were too long to transfer compressive forces if not braced laterally and thus could not withstand the design snow load.

Design drawings showed two 1 inch x 3 inch lateral members required for the first diagonal and one bracing for the second diagonal. However, this bracing was not carried out during construction.

This failure is due to on-site alterations, disregard of the design.

Source

Kagan, H.A., 1993: Common causes of collapse of metal-plate-connected wood roof trusses. In: *Journal of Performance of Constructed Facilities*, Vol. 7, No. 4, pages: 225-234 (case 2).

Case 64 – Collapse of nailed roof truss

Description of Structure

A townhouse complex was built using trusses with a span of 14.6 m.

Description of failure

Bundles of three trusses were lifted with a crane using a single-point lift at the peak of the trusses. The trusses were then walked-out and fixed with a spacer to the previously erected truss and even nailed to the walls. One of the workers always stood in the middle of the previously erected truss to provide for the joint with the spacer. When installing the last truss from a bundle, the previously installed truss collapsed when the worker stepped on it. The worker was injured.

Original investigation performed and conclusions

The investigation was complicated as the damaged truss was removed after failure and no photography evidence is left for analysis. Several factors may have contributed to the collapse:

1. Upon delivery of the trusses, the bundles of trusses were dropped from the truck to the ground (1.52 m height). It is possible that the collapsed truss got damaged during the dropping. Photography evidence from another truss bundle revealed one truss with broken lower chord. Recommendation: Unloading should be done with a crane.
2. Crane lift with single-point lift at the peak of the trusses was used. This technique is not recommended, as high stresses develop. Therefore, a spreader bar and a two-point pickup are recommended. Single-point lift could damage a truss or worsen the damage of an already damaged truss.
3. The trusses were inadequately braced and there was danger of collapse during the erection process.

It cannot be determined what caused the failure in this case, however, all three factors fall into the category “poor principles during erection”.

Source

Kagan, H.A., 1993: Common causes of collapse of metal-plate-connected wood roof trusses. In: *Journal of Performance of Constructed Facilities*, Vol. 7, No. 4, pages: 225-234 (case 3).

Case 65 – Deflection of truss

Description of Structure

A congregation hall is roofed with wooden trusses, spanning 26 m, in some cases cantilevering at one end up to 6.5 m. The trusses consist of single chords (200 mm x 240 mm), double verticals (2 times 100 mm x 240 mm) and single compressed diagonals (120 to 200 mm x 240 mm). The top and bottom chords are almost parallel. The tension verticals are connected to the chords with dowels, the compressed diagonals with traditional carpentry joints. All timber elements are of structural timber.

Description of failure

In 1997, problems with joints near the support were detected and immediately corrected. Some of the tension verticals had been substituted by steel tension posts. In spring 2001, deflections of the ceiling between 20 and 200 mm were observed, although there was no snow load on the roof.

Original investigation performed and conclusions

Not surprisingly, the largest deformations occur at mid-span in trusses without cantilever at the end. Some trusses have large drying (shrinkage) cracks. The compression diagonals have gaps in the connections to the chords, caused by shrinkage. Drying from too high moisture content caused gaps in (compression) connections and cracks in chords. Cracks in dowel joints in the upper and lower chord were caused by wrong positioning of the joint. The dowels were placed too close to the edge of the chord member. The large deflection and risk of collapse were caused by disregard of construction rules (positioning of tension joint, moisture effects).

Additional conclusions and comments

It is not quite sure from the original investigation whether the high moisture content is a design error or a construction error (i.e. whether dry timber was demanded in the design or not).

The load-bearing capacity of the roof structure is not adequate and the trusses have to be reinforced. It was suggested that steel plates should be nailed to the upper chords. Joints for tension members may be reinforced with self-tapping screws. Also joints between compressed diagonals and chords may be reinforced with self-tapping screws.

Source

Blass, H.J.: Beurteilung und Sanierung eines Holz-Fachwerkbinders. Ursache: Nichtbeachtung grundlegender konstruktiver Regeln. Downloaded from: <http://www.vpi-bw.com/bauherren.html>. "der aktuelle Fall"

Case 66 – Collapse of carport

Description of Structure

A carport 5.1 m by 5.6 m (suitable for two cars) was constructed with trusses with collar beams, supported by timber beams at the eaves. At the gable walls, horizontal timber beams were positioned, connected to the eaves beams and thus constituting a horizontal rectangle. The roof structure was supported by 5 columns (one each at each corner and one in the middle of one eave side). Crossing diagonal steel rods taking up the horizontal load and stabilizing the structure were installed in the horizontal plane of the rectangle of beams below the truss and in one gable side and one eaves side respectively.

The roof was covered with tiles. On the other gable side, a temporary half bracing was made with timber as the carport seemed unstable.

Description of failure

At only low wind velocities, the whole carport collapsed, injuring one of the workers (when working on a house next to the carport).

Original investigation performed and conclusions

The investigation showed that only two vertical truss bracings (“crosses”) were specified in the design, instead of three. A structure is only stable with three truss bracings. However, the crosses had been designed correctly. The joints with the columns however, were too weak for the design wind loads. The design of the anchorage of the columns overestimated the capacity.

The collapse was caused by a design error (only two stabilizing truss bracings instead of three).

Source

Wapenhans, W., Richter, J., 2002: Einsturzursachen für ein Carport, in: Stahlbau 71, Heft 3, pages 221-222.

Case 67 – Collapse of sports hall

Description of Structure

In 1973/74, a sports hall was built with concrete block walls and wooden trusses with nail plates. The dimensions of the hall were 18.24 m by 8.24 m and the trusses were placed with 600 mm centres. The roof pitch was 17.5°, the nominal dimensions were 175 mm x 50 mm (rafters) and 75 or 100 mm x 50 mm (diagonals).

Description of failure

On Sunday, July 3rd 1976, the roof collapsed, leading to partial collapse of the walls. The weather was calm, dry and hot (around 30°C) and even the days before, it had been warm (above 25°C).

Original investigation performed and conclusions

In the original investigation, several factors contributing to failure were found:

1. The timber found in the trusses had smaller actual dimensions than the nominal dimensions. However, despite the smaller dimensions the trusses can carry the design loads if they are kept in position. Only in the heel-joint, overstressing would occur in rafter and bottom chord due to design load.
2. Different nail plates than specified in the design were used. However, all joints were strong enough to transmit the design loads.
3. In 1975, a cold, damp atmosphere had been observed in the sports hall and heating equipment was installed to dry out the building. Together with the warm climate, this could result in looser joints between battens and rafters.
4. One important factor is lack of suitable bracing of the complete roof structure. Design drawings showed lateral bracings running through the building at mid-length of four compressed diagonals. However, only staggered bracing (fixing aid during installation) was present on two of the diagonals. Bracings were not tied positively to the gable walls. For outward forces, limit was thus the strength of the walls. Bracing consisted of longitudinal members, tiling battens, ceiling slats, gable walls and load bearing walls. The design did not contain adequate lateral bracing. There was no diagonal bracing in the plane of rafters or ceiling ties normal to the truss plane, providing substantial resistance to lateral movement of rafters, ties or trusses in the roof structure as a whole.
5. Other shortcomings: slenderness of the walls, restraint at top of load bearing wall, vertical shrinkage control joints near wall corners. Gable

walls were virtually free standing and unloaded. The walls were found to be inadequate in relation to design for lateral loads.

“The collapse (...) was caused by lateral instability of the trussed rafter roof because diagonal bracing of the roof structure was not provided. A progressive transfer of lateral loads from the roof structure to the gable walls occurred due to the unstable condition in the roof, resulting in collapse when the critical gable wall restraint was exceeded. The transfer of load to the gable walls may have been accelerated by the hot dry weather prior to the collapse, but this was a secondary rather than a primary cause of the failure which would probably have occurred under normal weather conditions at some later date. The trussed rafters in the roof structure were adequate to carry the vertical design loads (except for some overstressing under full design load which might occur in the region of the heel-joints) provided that they were restrained in position. The design included provision for suitable restraint to the diagonal compression members in the trusses but this restraint was not installed in the correct form in the actual construction. The principal shortcoming in the design of the building was the lack of suitable diagonal bracing of the complete roof structure to prevent movements of the trusses en bloc. These movements might take the form of lateral buckling of rafters, lateral bending of the trusses or sideways leaning of the trusses.”

Additional conclusions and comments

The cause of this collapse was categorized as design error (mechanical).

Source

Menzies, J.B., Grainger, G.D.: Report on the collapse of the Sports Hall at Rock Ferry Comprehensive School, Birkenhead. Building Research Establishment. BRE Current Paper October 1976, CP 69/76.

Case 68 - Fair Centre roof collapse, Jyväskylä

Description of structure

The structure was a truss-and-column structure. The columns were of reinforced concrete and the trusses made of glued laminated timber featured a span of 55 meters which is exceptionally large. The trusses had been manufactured in the plant by using dowel connections. In the dowel joints, two steel plates were slotted in the timber and 4 to 48 steel dowels - depending on the size of the joint - had been installed perpendicularly to them. The truss pair consisted of two identical trusses interconnected in parallel by screws.

Description of failure

On Saturday February 1st, 2003, an incident took place in Jyväskylä, where a Fair Center roof collapsed over an area about 2500 m², with the exterior wall also collapsing over a width of about 20 meters. The building was quite new with its B hall of altogether 7766 m² having been opened about two weeks earlier.

The previous day, a training and education fair organized in the Fair Center had ended, and on Saturday morning there were 12 Fair Centre employees and exhibitors' representatives stripping the stands in B hall. Suddenly a loud bang was heard from the roof of the hall, and some of the people inside went to see where the noise came from. Then someone discovered that one of the beams of the roof truss pair of laminated timber had broken on its narrow part close to the end of roof truss. The observers understood that the roof would possibly collapse and they yelled to the others to leave the hall. In an estimated two minutes time, the roof truss pair referred to, as well as the three following roof truss pairs and the roof elements supported by them, collapsed and fell down. All people had managed to leave the hall and no-one was injured.

Original investigation performed and conclusions

Investigation was made by Finnish Accidents Investigation Board (part of state administration). Work was initiated on Saturday February 1st, 2003 and completed May 31st 2004.

Already at the initial phase of the investigation of the incident, it became evident that according to the eye-witnesses, one joint of the truss of the roof truss pair having first collapsed, only had 7 dowels while according to the plans, their number should have been 33. In fact the collapse commenced as caused by this control negligence by the truss manufacturer. At the time of the incident the snow load was measured as being about 25 % (i.e. 0.5 kN/m²) of the design snow load used. Only one truss of the truss pair displayed missing dowels. Hence the damage ought to have been limited only to those trusses. Instead, a collapse was generated and it proceeded as the major dowel joints broke in a cleavage fracture mode, that is, the joint section had torn off the timber along the outer rows of dowel group.

The European pre-standard (Eurocode 5, ENV 1995-1-1) used as design guideline in the design of the trusses, fails to consider such a type of fracture, and therefore the strength of the biggest joint only featured about 50 % of the planned value. According to the investigation commission, the errors discovered in the guidelines imply deficiencies in drafting the norms. Already several years before the incident, the deficiencies had in fact been corrected in a more recent draft of the Eurocode 5 and the problematic issues had been discussed in a Finnish technical journal. Hence the errors were well known by a limited circle of experts. However, the document used in design was officially accepted for use and was not amended.

Additional conclusions and comments

The conclusions from the original investigation seem reliable. In addition to missing dowels and inadequate design guidelines, quality problems in manufacture of trusses were observed. However, these did not affect to the failure, because the two major reasons were dominating.

Case 69 – Collapse of glulam beam in industrial building

Description of structure

The roof structure of an industrial building was made from glulam beams about 30 years ago. The height of beams was 1045 mm, width 160 mm, span 15.2 m, and spacing between beams was 5 m, see figure 69-1. Below the beam, attached to it, was a heat insulated air pipe, transporting air at a temperature of 180°C. The air temperature close to the beam was 50-60°C continuously. The load of the beam had been raised during the year preceding failure due to structural changes in the building. No snow was on the roof at any time because of high temperature.

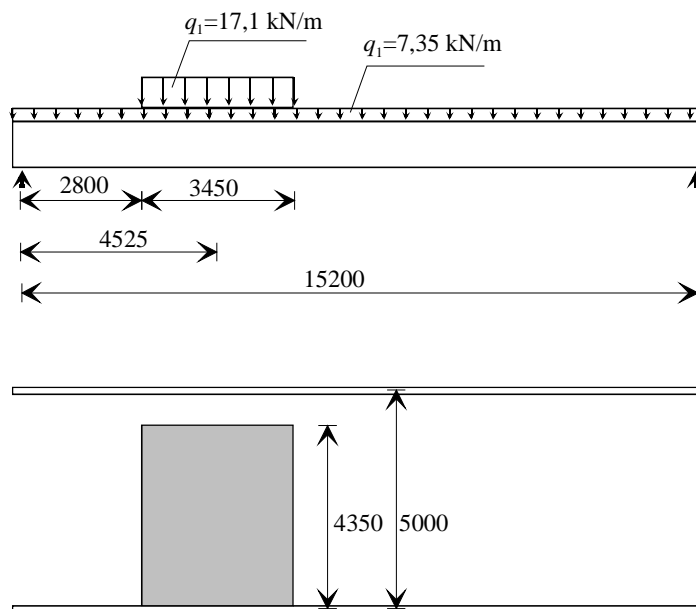

Figure 69-1: Dimensions of the main beams and top view of 2 beams and the insulated air pipe in-between.

Description of failure

On a Friday the workers heard a bang, but it was thought to be caused by normal industrial activity. On Saturday, the beam collapsed, but did not fall down because of a drying chamber below supported it. It may also be the reason for the collapse not proceeding to other beams.

Bending failure took place at the location where heat insulation of the pipe touched the beam, and the beam was charred in that area.

Original investigation performed and conclusions

VTT made an investigation on site during the week following the incident. The broken beam was cut into three pieces and moved outside the building. It was observed that the beam had bending failure at a section 4,9 m from the end, which is where the hot air channel is located. Moisture content of the broken beam was 7 %. Bending stress in the critical section when the failure occurred was estimated to have been 14.3 MPa, and shear stress 0.34 MPa. Bending stress is 75% and shear stress 23% of design strength of Finnish L40 glulam.

Additional conclusions and comments

The conclusions from the original investigation seem reliable. The designer had not known that the beam will be heated too much.

Case 70 – Collapse of industrial hall building

Description of structure

Nail plate connected trusses were supported on three vertical support lines with distance of 20.1 m from each other. The external vertical structures were timber walls with studs 42x142x4053 mm c/c 600 mm. Middle supports were glulam columns 210x420x4054 mm (b×h×L) c/c 6.25 m supporting a longitudinal glulam beam 210x810 (b×h), see figure 70-1.

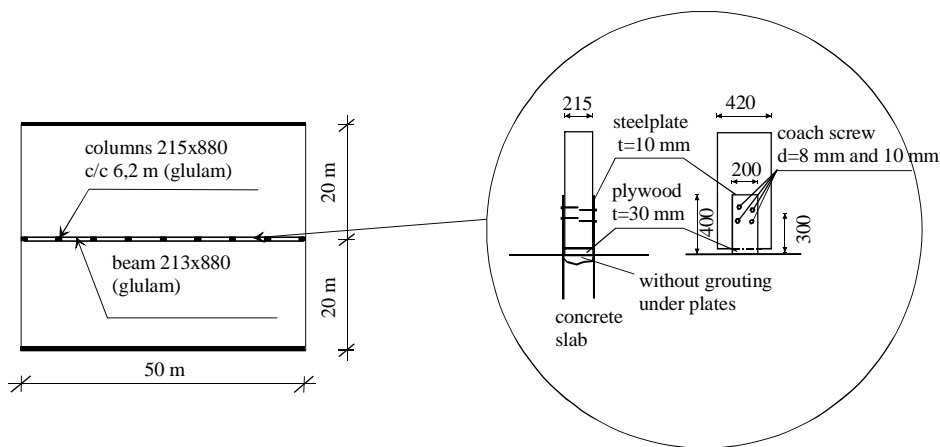

Figure 70-1: Detail of the column connections which provide the only lateral support in the span direction.

Description of failure

According to the information of the customer, collapse of the building of size 2000 m² was observed on March 10th, 1999, at 19.30. The collapse occurred in the middle one of three consecutive halls. The building had been built during fall 1997 and was in process to be taken into service. In all, 8 similar halls were built in the same area.

Original investigation performed and conclusions

VTT investigated the site on March 16th, 1999, when the pieces of the collapsed building were still in place. The building had collapsed almost totally. Only glulam columns were standing and carrying the glulam beam. Columns were tilted at least 200 mm to north. Both external walls had fallen down outwards, and roof trusses were fallen and broken.

Reason of collapse was that racking resistance of the building was missing. Only 1% of the required capacity against horizontal loads was detected!

Additional conclusions and comments

The conclusions from the original investigation seem reliable.

Case 71 – Collapsed glulam beam in swimming hall, Iisalmi

Description of structure

The Indoor Swimming Pool Centre had been expanded and renovated during 1995 and 1996 with the combined flat and arched roof construction having been changed to mono-pitch roof construction, see figure 71-1. After the change, the laminated beam in question had to carry the loads of an area twice as much as earlier, as the arched roof construction transmits the vertical loads of the curved area to the support of the beam ends.

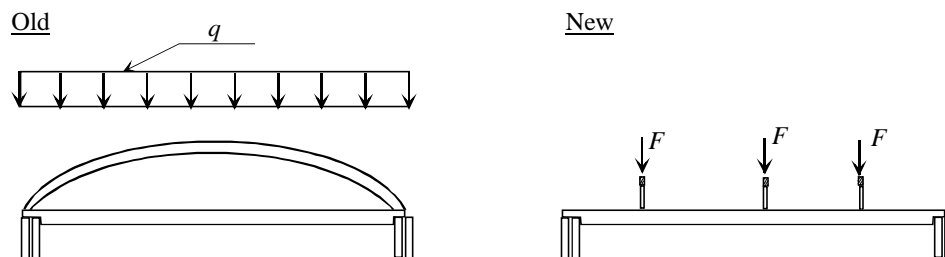

Figure 71-1: Old (left) and new (right) roof structures.

Description of failure

On Wednesday March 29th, 2000 early in the morning an incident arose as the roof of the Indoor Swimming Pool Centre at Iisalmi threatened to collapse. In fact one of the laminated beams supporting the roof structure above a swimming pool broke entailing a gradual slow settlement of the roof.

When the roof construction had been changed, the designer had failed to consider the increase in the stresses. As a result, in the bolted joint area of the beam end, a tension fracture perpendicular to the grain of the beam was generated. The beam first cracked horizontally in many places to finally break due to the bending stress.

Original investigation performed and conclusions

The researchers of Accidents investigation Board investigated the site starting the day of the incident, when the beam was supported and snow removal was being done. Snow load was estimated having been 1,3 kN/m², which is 2/3 of the design snow load. Reason of collapse was design error: the structure was changed without change of beam supports.

Additional conclusions and comments

The conclusions from the original investigation seem reliable. Change of roof supports was a small part of enlargement of swimming hall, which may explain why the severity of this structural change was not noticed by the designer.

Case 72 - Collapse of ceiling in supermarket

Description of structure

The ceiling strips $50 \times 50 \text{ mm}^2$ are nailed to the roof trusses as a rule by two machine nails 90×3.1 per joint see figure 72-1. The load was axial, withdrawal load for nails, consisting of dead load of ceiling, insulation material, electrical cables and ventilation channels.

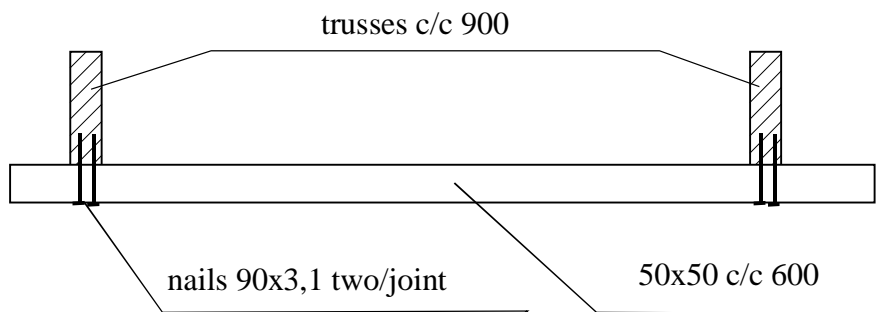

Figure 72-1: Support connection of inner ceiling.

Description of failure

The ceiling of a supermarket collapsed (together with heating pipes, refrigeration apparatus pipes, water pipes, ventilation ducts, electric wires and shelves fixed to the ceiling) on December 27th, 2000 at 21.24 about 20 minutes after the supermarket had been closed. The collapsed area was about 1700 m². No personal injuries occurred.

Original investigation performed and conclusions

The researchers of Accident Investigation Board started the investigation on December 28th, 2000 and the report was completed June 6th, 2001.

The direct technical cause of the accident was the insufficient capacity of the nail joint between the $50 \times 50 \text{ mm}$ ceiling strips and the roof trusses, to carry the loads of the ceiling. As a rule, the nail joint featured two $90 \times 3.1 \text{ mm}$ machine nails that ensure the joint a characteristic capacity of 326 N/m^2 to resist suspension loads, as calculated in conformity with norms and standards. However according to the calculations made by Accident Investigation Board of Finland, in certain areas, the suspension loads including the dead weight of the ceiling, totaled 337 N/m^2 on average. In addition some smaller areas of the ceiling were charged by high concentrated loads generated by the suspensions.

The nail joints had been realized as contrary to the plans, as the designer of the structure had equipped the joint with three 100x3,3 nails. However in practice the planned joint failed to be viable, as nowadays almost all work sites use machine nails with maximum length up to 90 mm. Furthermore the joint area between the strip and the roof truss is not big enough - in terms of the relevant norms and standards - to permit three nails to be fixed therein. The characteristic capacity of the designed nail joint corresponds to suspension loads of 677 N/m^2 which would have been also insufficient to carry the concentrated loads.

Additional conclusions and comments

The physical damage totals 1,2 million Euros.

This incident is an example of at least 10 similar collapses. In other cases the physical damage has been smaller, and no personal injuries have taken place in any of these collapses. One of the latest incidents took place in April 2005, and the report was completed by 9.11.2005.

Case 73 – Overturn of glulam trusses during their installation

Description of structure

The structure consists of three-hinge-arches supported by columns. Span width is 44 m and the rising height of the arch is 6.2 m. The cross-section of the glulam arch is $b \times h = 190 \times 1260$ mm. Roof panels were planned to be installed on top of the arches. Vertical members were fixed between the arches. Lateral tension loads between arches during installation were carried by temporary rope type binders. In the final structure, lateral tension loads are carried by the roof structure. Figure 73-1 below illustrates the structures installed at the time of collapse.

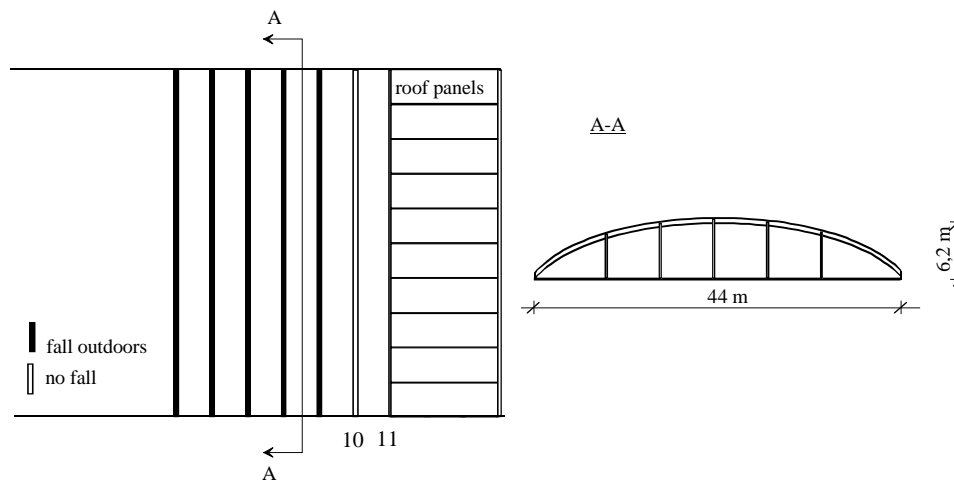

Figure 73-1: Structures installed at the time of failure.

Description of failure

On February, 15th, 2001, five temporarily supported arches fell down.

Original investigation performed and conclusions

VTT investigated the case during late summer of 2001 based on documents submitted by the customer. Documents included design drawings, installation plan, reports made by different parties on the reasons of collapse and photographs. The following conclusions were made on the likely reasons:

1. Vertical members (in which the ropes were fixed) broke by the tension force in ropes caused by wind load or

2. ropes loosened because of wind induced swinging and at the end sliding down or
3. Arches have buckled out of plane because they were supported only in 3 places on the 44 m distance

In the two first options the reason has been the fixing of ropes to the verticals. The last option is also possible, even in the case when only dead load is causing compression in the arches.

Additional conclusions and comments

Most probable reason of failure is that the ropes have not been properly fixed and have been sliding down along the verticals. This is supported by the fact that arch 10 did not overturn. It was fastened to arch 11 by a rope around arch 10 itself, and not around the vertical. The long time between incident and VTT study makes it difficult to draw firm conclusions.

Case 74 – Roof collapse of market under construction

Description of structure

The roof structure consists of 20 m long nail plate connected trusses. At one end, on top of the trusses, a frame was built to reshape the roof as needed for an L-shaped building, see figure 74-1. The frames were located at 1200 mm distance from each other. In the design calculation, weight of the roof structure was 0.3 kN/m^2 and snow load was 1.8 kN/m^2 . In addition, in the collapsed part, there was a 400 m^2 area covered by 200 mm wood chips and a 70 m^2 area covered by maximum 2 m cutter chips.

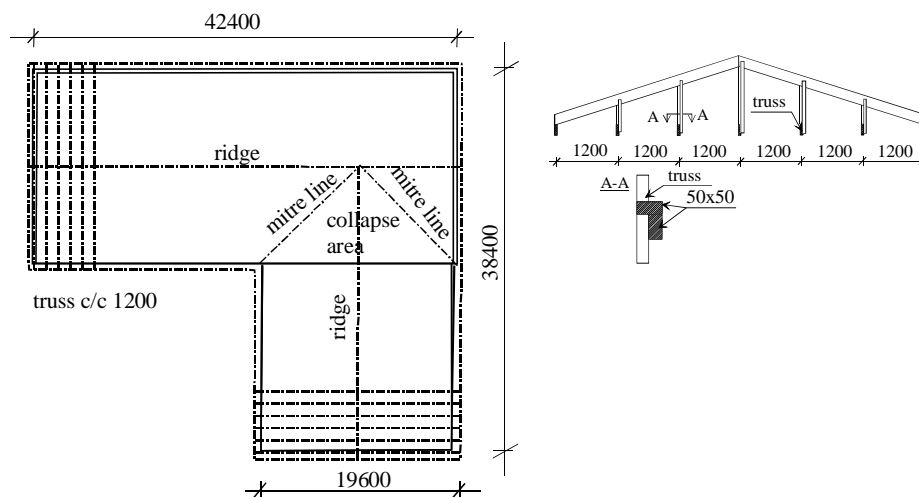

Figure 74-1: Roof structure of market building.

Description of failure

The roof collapsed totally in the area of the wider building, and a small damage occurred in the narrow wing of the building. Wall panels in the main part of the building collapsed and twisted to bad shape. During failure, the weather was windy and the snow depth was 200 mm. Load was increased by cutter chips used as insulation material, and which might have had increased moisture content because of concreting of floor.

(it was learned later that this additional load had no importance for the incident).

Original investigation performed and conclusions

VTT investigated the case on site on December 19th, 1995. The following observations were made:

- In the area of the added frame structure, the upper chords of trusses had buckled laterally and in many cases broken at the joint of the upper chord.
- Also lower chords had broken at nail plate joints in the same area.
- In other areas the tension joint of the lower chord had broken followed by breakage of the nail plate at the ridge.

Snow load was 0.3 kN/m² and wind speed 8-10 m/s.

The primary reason of collapse was lateral buckling of the compressed upper chords in the area of the added roof shaping structure. Lateral supports were totally lacking in this area.

Additional conclusions and comments

Two other similar cases have taken place (1984, 1987).

Case 75 – Roof collapse of manege (drill hall)

Description of structure

Nail plated connected trusses were used as roof structure of a manege. The timber frame building was not heat insulated. Span of trusses was 22 m, height 3.6 m, slope of roof 14°. Roof boards 35x72 mm² were placed with c/c 600 mm. Length of the building was 45 m and it had an elevated part in the middle for roof windows, see figure 75-1. The size of this elevated part was 4.8 m in direction of the truss span, 20 m in length direction of the building and it had a height of 2 m. This elevated structure had its own roof trusses with a span of 4.8 m. These trusses were supported on top of the long trusses by 1.6 m long studs corresponding to the height of the window.

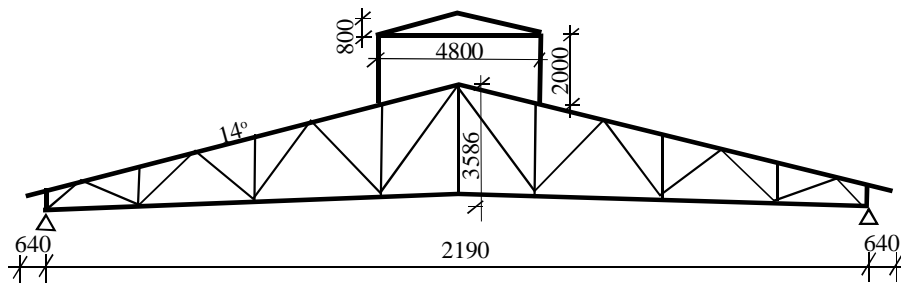

Figure 75-1: Roof structure with elevated part.

Description of failure

The roof of the 5-year-old building totally collapsed during the night of February 15th to 16th, 1996. Most of the load bearing walls fell down. During the collapse, the weather was windy and the snow load was 2020 kg/m², locally close to the roof window possibly three times as much. The design snow load was 1.8 kN/m².

Original investigation performed and conclusions

VTT investigated the site on February 17th, 1996. It was concluded that the collapse had started in the area of the roof windows, where unsupported upper chords of the roof trusses had buckled laterally in the area of the elevated roof structure. After collapse in the elevated roof area, the collapse had proceeded towards both ends of the building. Continuation of collapse was caused by the roof pulling the trusses to overturn.

The designer had planned that all upper chords of the 22 m long trusses are laterally supported (c/c 600 mm) and that the roofing material is stiff and fixed to the roof boards. In the area of the roof window the lateral supports were lacking and the maximum distance of lateral supports was 4.8m. It has been told that the roof window was a deviation from the original plan. This is supported by the fact that the small trusses for the roof windows were purchased later on.

Case 76 – Collapse of new emergency exit of ice rink

Description of structure

The roof structure was an arch, with straight roof parts at both ends. The inclination of the collapsed straight part was 1:20, see figure 76-1 below. The arch was made of glulam and the collapsed straight part of kerto-LVL beams $b \times h = 62 \times 400 \text{ mm}^2$ spaced at c/c 1050 mm with a span of 7.5 m.

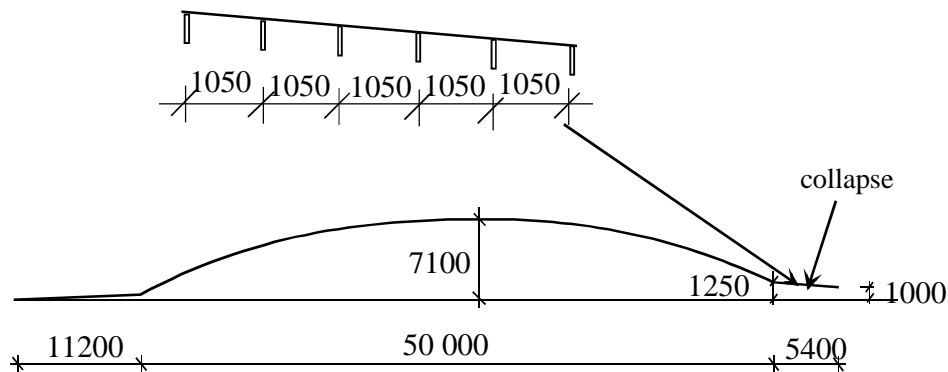

Figure 76-1: Roof structure of ice rink. The straight part on the right side of the building collapsed.

Description of failure

The straight roof part shown in figure 76-1 collapsed in spring 2000.

Original investigation performed and conclusions

A VTT investigator inspected the site only after the structure was repaired.

Based on given information, the snow had slid from the arch onto the straight portion of the roof. It is thus possible that the sliding snow has resulted in high snow loads prior to failure.

The snow load during failure was considerably smaller than what was assumed in the design of 2.0 kN/m^2 .

The beam bending stresses exceeded the capacity by 12 % and the deflection exceeded the allowable deflection by 26 %. This is based on assuming the accumulation of snow in the folding roof part as given in the loading standard. The documents at hand did not

show how the beams are to be prevented from falling sideways. If such support was not constructed, this should be the primary reason of the failure.

Additional conclusions and comments

The investigation was difficult since the failed structures had been removed beforehand. It was not clear either if the snow had slid from the arch before or after failure. In any case the beams should fall sideways if this was constructed according to the plan. The failure is classified as design failure.

Case 77 – Cow-house roof failure

Description of structure

The insulated hall building had a width of 21 m, a length of about 37 m and height of 3.5 m. The walls were constructed of insulated concrete bricks.

The roof structure was made of nail plate trusses which were supported by the external walls and by an internal wall. The truss' lower chord was of length 20.9 m, the rising height 4.3 m, but it was cut at a height of 3.6 m. The top of the truss was installed on the building site. The truss spacing was 1200 mm. The trusses were supported on top of a flatwise wood member of size 50 x 125 mm.

Description of failure

The building collapsed in February 2003.

Original investigation performed and conclusions

An investigator from VTT visited the site before it was cleaned up. The top chord of all the trusses had buckled in the same direction towards the end of the building. The lower chords failed at the connections probably after the buckling of top chords.

The top chords of the trusses, which were connected to each other, were not stabilized to any laterally stiff structure. Additionally, the moisture in the roof was high.

The snow load was about 1 kN/m² at the time of failure. The value used in the design was 1.5 kN/m².

The measured wood moisture content in the roof structure was between 24 and 28 %. Mould was also encountered in the structure, but no rot. At the instant of failure the wood chip insulation layer of 300 mm of the roof was assumed to give a load of 20 kg/m² on the roof.

The moisture in the roof was caused by the animals inside and the air was ventilated to the attic, but there was no ventilation from the attic to outdoors. The nail plates had white stain caused by the oxidation of zinc. This would have caused a corrosion failure of the nail plates if the conditions would have prolonged.

Additional conclusions and comments

Based on the owners information, the building was self-built during 1998-1999, and it was used as a cow house since 2001. The nail plate truss deliverer has an appropriate certification and there were no faults found in the design of the trusses.

Case 78 – Roof collapse of a beef cattle house

Description of structure

The building was a heat insulated hall of width 25 m and length 50 m. The load bearing external walls were concrete elements of height 3 m. Additionally, at the centre span, there was an internal load bearing wall along the length of the hall of height 4 m. The other end of the hall was attached to a separate building for animal feed storage. However, no force transfer was possible between the buildings. The hall was symmetric along the length of the building. The roof was constructed with nail plate trusses. The trusses were supported by the external wall and by the internal wall. The length of the lower chord was 12.7 m and the rising height was 0.6 m at the external support and 2.8 m at the rooftop. The truss spacing was 870 mm for the first seven trusses and 1250 mm elsewhere. The trusses were supported on a pressure treated wooden top plate 50 x 150 mm² attached to the wall top.

Description of failure

The roof partially collapsed in February 2004. The collapse stopped about halfway of the lengthwise direction of the building, where there was a ventilation chimney from which some support to the roof resulted.

Original investigation performed and conclusions

An investigator from VTT visited the site before it was cleaned up.

The failure cause was an unbraced vertical compressed member of the trusses 7 to 12 m from the end of the hall adjacent to the other building. Rails for transporting animal feed transferred the loads from the failed trusses to the other trusses and caused the other trusses to fall. The collapse stopped at a 23 m distance, where there was a ventilation chimney that supported the roof.

The snow load on the roof was about 1 kN/m² on the standing roof part. On the failed roof part the snow load could have been about 1.6 kN/m², based on observations of accumulated snow between the two buildings. According to the design standard, at this location the snow load is to be taken as 2.1 kN/m² (when not considering any accumulation effects) and this value should be multiplied by a partial load factor of 1.5.

The top chords of the trusses were coloured dark because of moisture. Probably moisture has condensed on the lower surface of the roof covering sheeting. The nail plates were also coloured white because of oxidation. The animals have produced the moisture. The measured wood moisture content was however in a normal level corresponding to the outdoor sheltered condition at this season.

No faults were discovered in the design of the trusses.

Case 79 – Failure of glulam beam, Vantaa

Description of structure

The roof structure of this office building, located in Vantaa, consisted of straight glulam beams carrying hollow-core lightweight concrete slabs (Siporex-slabs). The glulam beam span was 12 m and their spacing was 5 m. The cross section was $b \times h = 137 \times 900 \text{ mm}^2$. At about centre span in the middle of the section there was a circular hole with a diameter of 300 mm, which is about a third of the cross section. These glulam beams carried 200 mm high siporex slabs. The self weight of the roof was in total 1.6 kN/m^2 .

Description of failure

Failure took place in 1997. One glulam beam failed at the centre where a hole for a ventilation duct was located. The bending stress caused by the permanent load was 8 MPa. The other beams did not fail.

Original investigation performed and conclusions

A VTT investigator visited the site on June 26th, 1997. During the inspection the failed beam was visible and supported on site. From an on site analysis, it was deduced that the beam had failed due to bending stresses in the lower beam part below the hole. The failed section was cut and sent to VTT for a further analysis.

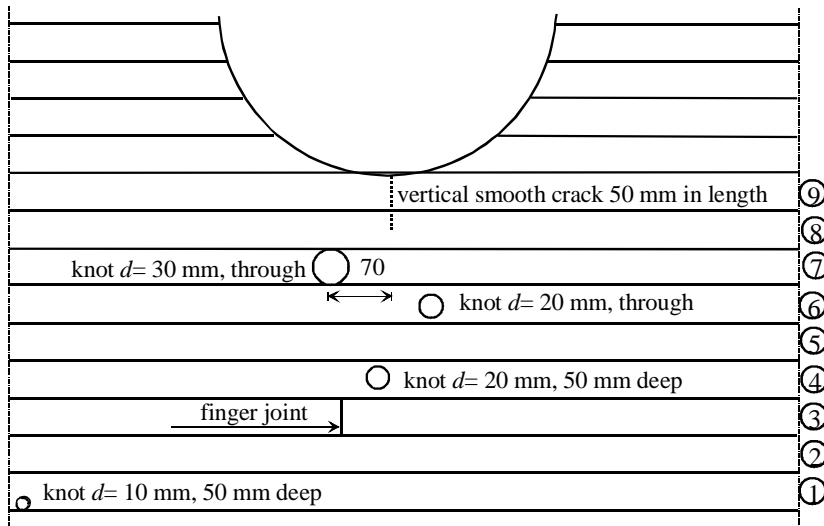

Figure 79-1: Part of fractured beam.

Figure 79-1 above shows the observations from the failed section. The circles represent knots in the section. There was a 50 mm deep vertical crack in the beam with very smooth surfaces which were dirty and thus probably older than the failure.

The beam was designed for the self weight and a snow load of 1.8 kN/m^2 . This results in a bending stress of 16.7 MPa, in case that there is no hole and 4 % higher with the hole. The beam did satisfy the design.

The beam failed during summer with no snow loads and the bending stress at this time would be only 8 MPa. This loading should not normally cause failure. The failed section did however contain more knots and other weakening effects. The inner lamellae did not satisfy the LT300 grading requirements, since the lamellae had knots on both edges. This grade was used in the design. The wood density was 391 and 408 kg/m^3 , which is lower than required for LT300 (which is 450 kg/m^3 for pine and 420 kg/m^3 for spruce at moisture content of 15 %). No biological deterioration was detected.

Additional conclusions and comments

No specific reason was found why failure took place at such a low stress level. No rot was observed.

Case 80 – Failure of frames in single family house, Kemijärvi

Description of structure

A new single family house had a roof consisting of nail plate connected frames.

Description of failure

In 1992, large deflections were observed in roof and beams. However, no collapse occurred.

Original investigation performed and conclusions

Investigation was made by a structural engineering student for his diploma work [1] by interviewing parties of the dispute. His conclusions included:

- The shape of the frame is sensitive to deformations because of unsymmetrical supports
- The designer did not consider loads adequately
- An error occurred in installation of one frame

Source

Törmänen J.; Leskelä M. Failures in timber structures (in Finnish: Kantavien puurakenteiden vaurioselvitys, tutkimusraportti RTL 0021). University of Oulu, 1996

Case 81 – Failure of enlargement of industrial hall, Oulainen

Description of structure

The roof of an industrial building collapsed partially (about half) in 1994. The span of the old part was 20.3 m and attached to this a new part with span of also 20.3 m was built. The trusses of the new part were partially also on top of the old trusses to produce a pitched roof with two symmetric inclinations.

Description of failure

The newly built enlargement of the hall collapsed because of lack of bracing of the roof. The snow depth on the roof was 0.25 to 0.3 m and in some places 0.5 m. The snow was wet, because it had rained the same day.

Original investigation performed and conclusions

Investigation was made by a structural engineering student for his diploma work based on information received from designer and local authorities. His conclusions included:

There was no structural design made of the bracing of the roof structure.

The truss design mentioned support of a compressed member against buckling and this was constructed. But the truss design did not consider the support of the whole roof, it was only mentioned that the bracing of the roof is to be done as presented by the main designer.

The main structural designer was from the concrete element supplier.

Additionally the spacing of the roof battens was about 1500 mm although in the design it was specified as 600 mm.

Source

Törmänen J.; Leskelä M. Failures in timber structures (in Finnish: Kantavien puurakenteiden vaurioselvitys, tutkimusraportti RTL 0021). University of Oulu, 1996

Case 82 – Partial collapse of industrial hall, Pello

Description of structure

An industrial hall was constructed with self-made nailed trusses. The structure was built in 1987 with a surface area of 800 m². The trusses were supported by external walls and by an internal wall. The span of the triangular trusses was 10 m (from external wall to internal wall). They were spaced at c/c 1200 mm.

Description of failure

24 trusses failed covering an area of 300 m² in March 1991.

Original investigation performed and conclusions

Investigation was made by a structural engineering student for his diploma work based on information received from designer, VTT report and local authorities [1]. His conclusions included:

No faults were discovered in the structural design.

On the other hand, several construction faults were found. The structure was not built as planned and the quality was not good.

The roof was supported by nailed roof trusses and these had the following faults:

- the wood members did not align correctly at connections,
- there were less nails present than in the design
- the bracing considered in the design was not constructed

Source

Törmänen J.; Leskelä M. Failures in timber structures (in Finnish: Kantavien puurakenteiden vaurioselvitys, tutkimusraportti RTL 0021). University of Oulu, 1996

Case 83 – Partial collapse of supermarket roof, Ranua

Description of structure

The supermarket was built in 1987 with nail plate trusses spanning 18 m. The walls were timber framed.

Description of failure

The roof collapsed in March 1988 over a distance of 26.5 m involving 33 trusses.

The snow load at the failure occasion was very high, about 1.25 times the characteristic load.

Original investigation performed and conclusions

VTT had investigated the case. Summary was made by a structural engineering student for his diploma work based on information received from designer and local authorities. His conclusions included:

The whole roof was lacking bracing and several long compressed members were lacking lateral support, which was presented in the structural design.

The support lengths required in the design were not fulfilled in practice.

Source

Törmänen J.; Leskelä M. Failures in timber structures (in Finnish: Kantavien puurakenteiden vaurioselvitys, tutkimusraportti RTL 0021). University of Oulu, 1996

Case 84 – Collapse of roof of car store, Rovaniemi

Description of structure

A car dealer building was built 1989. The floor area was 1400 m². The roof was supported by prefabricated nail plate connected trusses. The width of the building was 30 m and trusses were supported also at the centre of the building on a glulam beam. The span was 14.8 m. Roofing material was tile.

Description of failure

Failure took place in March 1991 when the shop was open. The collapsed area was 300 m² involving the trusses of one span at the end of the building. People had time to escape the building and no injuries occurred.

Original investigation performed and conclusions

Snow load at the time of failure was maximum of that year, but within normal values. Investigation was made by a professor when giving expert opinion to court of justice. A summary has been published. His conclusions included:

- Based on eye witness observation, the initial reason was lateral buckling of the compressed diagonal. Lateral supports were lacking which was a design error.
- In manufacture of the trusses, the nail plate connecting the most stressed tensile diagonal to the lower chord had been replaced by several smaller nail plates having the same total area as the plate determined by the designer. This caused splitting of the lower chord of several consecutive trusses, and loosening of the tension diagonal.
- Fixing of roof boards was not proper, and they did not act as lateral supports of the upper chord.
- During construction the trusses were overloaded by large piles of tiles (1175 kg).
- Racking resistance of roof and building was not designed.

Source

Törmänen J.; Leskelä M. Failures in timber structures (in Finnish: Kantavien puurakenteiden vaurioselvitys, tutkimusraportti RTL 0021). University of Oulu, 1996

Case 85 – Collapse of roof of industrial hall, Kitee

Description of structure

The structure is an industrial building with glulam beams.

Description of failure

In 1982, bending failure of glulam beam occurred. The snow load exceeded the design value.

Original investigation performed and conclusions

No proper investigation was made because the snow load exceeded the code value. Information was collected later by a structural engineering student for his diploma work from insurance company and local authorities. His conclusions included:

- The snow load was assumed to be the reason for failure. There were problems also in other buildings 1982 caused by snow load.
- There have been 4 other collapses of glulam beams which have been only superficially investigated and documented. All had different reasons: leakage of roofing causing decay of glulam, extra snow load drifting on roof behind a show sign, design error of compression perpendicular to grain, and in the last case errors in design and erection.

Additional conclusions and comments

These early cases are not well documented and the real reason is not known especially in case when exceeding the code value was said to be the only reason for failure.

Two similar cases occurred in Kuopio and one case in Mikkeli.

Source

Törmänen J.; Leskelä M. Failures in timber structures (in Finnish: Kantavien puurakenteiden vaurioselvitys, tutkimusraportti RTL 0021). University of Oulu, 1996

Case 86 – Collapse of roof of chicken farm, Alavus

Description of structure

This was an agricultural building (hen house), which was built in the 1970's . The roof structure was constructed of nailed wooden trusses. The width of the building was 20 m and it had a load bearing internal wall. The truss spacing was 1.8 m.

Description of failure

The roof trusses had already earlier sideways deflections and these were supported during the previous summer (1987). In January 1988, a quarter of the roof area failed. The roof material was minerite boarding and this prevented the snow from sliding. There was plenty of snow and ice on the roof.

Original investigation performed and conclusions

Investigation was made by a structural engineering student for his diploma work based on information received from private investigators and local authorities. His conclusions included:

The connection of the roof battens to the trusses was not appropriate. The roof battens were spaced at 0.9 to 1.0 m, but the spacing should have been only 0.45 m according to the design. The battens should have been nailed to both upper chord members as was mentioned in the design. Additionally, the use of size 50 x 100 mm² on edgewise bending as battens is questionable as these may turn due to the section height.

Some compression members that were supposed to be supported against buckling lacked this support.

The trusses were not supported against sideways falling and there was no bracing design done.

Source

Törmänen J.; Leskelä M. Failures in timber structures (in Finnish: Kantavien puurakenteiden vaurioselvitys, tutkimusraportti RTL 0021). University of Oulu, 1996

Case 87– Collapse of roof of industrial hall, Jyväskylä

Description of structure

The industrial building had three parts: two heated rooms and one non-heated in between. The roof of the non-heated part had no heat insulation, and roofing material was steel sheathing.

The roof was constructed with nailed wooden trusses and the span was about 15 m.

Description of failure

The roof of the unheated part of the building collapsed during winter 1994-1995.

Original investigation performed and conclusions

Investigation was made by a structural engineering student for his diploma work based on information received from local authorities. His conclusions included:

- The snow and ice load in the collapsed part was estimated to 2.5 kN/m^2 on average. Ice was formed because of heat flow through the non-insulated roof. Load only partly explains the collapse.
- Trusses were covered by ice because condensed water had been dropping directly on the trusses.
- No investigation was made directly after collapse.

Additional conclusions and comments

Probably the reason of collapse has been a combination of large load and wet wood. The case is unique, because the heat and air flow from the heated part of the building to the unheated one is the basic reason for collapse. Building physical design or execution was not made correctly.

Source

Törmänen J.; Leskelä M. Failures in timber structures (in Finnish: Kantavien puurakenteiden vaurioselvitys, tutkimusraportti RTL 0021). University of Oulu, 1996

Case 88 – Roof collapse of L-shaped building, Jämsä

Description of structure

The building is a L-shaped industrial building, where the roof was constructed with glued wood trusses. The chords were double-member and the single web members were connected in-between. The span was 15.9 m.

Description of failure

The roof collapsed in March 1984. The snow load was at most 1.8 kN/m^2 at this time.

Original investigation performed and conclusions

Investigation was made by VTT and later by a structural engineering student for his diploma work based on VTT report and information received from designer and local authorities. His conclusions included:

The roof battens were spaced at 0.6 m and these were connected only to the other upper chord member (in turns), so the real spacing was 1.2 m. In the truss design the spacing was assumed as 0.4 m.

The design for roof bracing was not done and it was not realised in construction.

Source

Törmänen J.; Leskelä M. Failures in timber structures (in Finnish: Kantavien puurakenteiden vaurioselvitys, tutkimusraportti RTL 0021). University of Oulu, 1996

Case 89 – Design error of roof trusses, Kemijärvi

Description of structure

In a storage house the roof was constructed with nail plate trusses with a span of 14.1 m.

Description of failure

No collapse occurred as the truss deficiencies were noticed during construction.

Original investigation performed and conclusions

Investigation was made by a structural engineering student for his diploma work based on information received from designer and local authorities. His conclusions included:

The same trusses were used in different places of the building although there were significant differences in support locations.

The truss members were not properly placed (discontinuity in mid-span), see figure 89-1. The top chord is not aligned causing a high bending load on the vertical member.

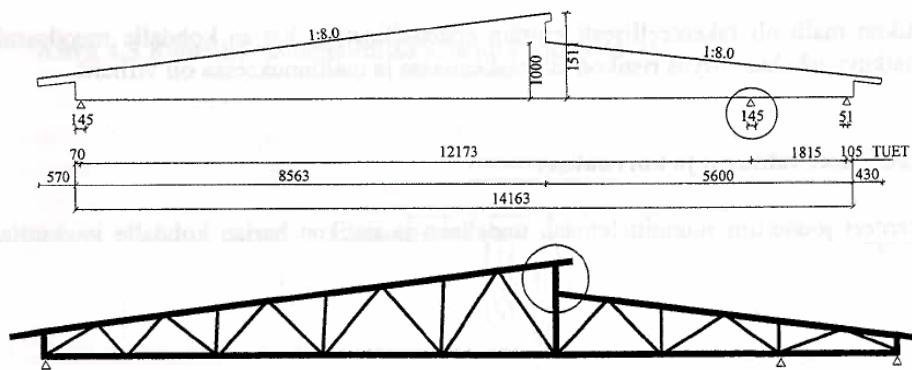

Figure 89-1: The top chord is not aligned at centre span causing a high bending load on the vertical member.

Source

Törmänen J.; Leskelä M. Failures in timber structures (in Finnish: Kantavien puurakenteiden vaurioselvitys, tutkimusraportti RTL 0021). University of Oulu, 1996

Case 90 – Tilting of roof trusses, Mikkeli

Description of structure

This 9 year old double span industrial building was constructed with wooden trusses. The span was 15 m and the rising height was 2.5 m.

Description of failure

The trusses inclined sideways by about 200 mm during winter 1994.

Original investigation performed and conclusions

Investigation was made by a structural engineering student for his diploma work based on information received from designer and local authorities. His conclusions included:

No bracing design was done for the roof.

Only temporary bracing members for the assembly still existed on the roof. Also it was suspected that the trusses were originally assembled in an inclined position.

Source

Törmänen J.; Leskelä M. Failures in timber structures (in Finnish: Kantavien puurakenteiden vaurioselvitys, tutkimusraportti RTL 0021). University of Oulu, 1996

Case 91 – Collapse of industrial L-shaped roof, Tampere

Description of structure

This was a L-shaped industrial building where the roof was constructed with nail plate trusses. The truss span was 19.5 m and the height was 3.24 m.

Description of failure

The entire one side of the L shape roof collapsed in december 1992. There was only 0.2 m of snow, but it was a windy day.

Original investigation performed and conclusions

Investigation was made by a structural engineering student for his diploma work based on information received from designer and local authorities. His conclusions included:

The lateral support of the compressed top chord was not proper. From the junction area on the L-shape roof the battens were spaced at 1.2 m although these were assumed to be spaced at 0.6 m in the design.

Not all compressed members were supported as mentioned in the design.

No roof bracing design was carried out and no bracing structures existed, except for some temporary assembly supports which were left in place.

The support length according to the design was 277 mm. There is no information if this was really so, but such a long support would require a special design.

Additional conclusions and comments

Similar to case 75 in principle.

Source

Törmänen J.; Leskelä M. Failures in timber structures (in Finnish: Kantavien puurakenteiden vaurioselvitys, tutkimusraportti RTL 0021). University of Oulu, 1996

Case 92 – Failure of glulam arch, Heinola, Lahti, Laukaa

Description of structure

This case represents three similar cylindrical halls, located in three different towns. The arches were made of glulam and a plywood boxed structure. The arch ends were located outdoors, without weather protection. The structures were designed in the 1970's.

Description of failure

Decay of wood was observed in the outdoor parts of the arches. No collapses took place.

Original investigation performed and conclusions

Investigation was made by a structural engineering student for his diploma work based on information received from local authorities. His conclusion was that risk of decay had not been taken into consideration properly by the designer. Ends of arches were exposed to rain and snow without protection. It was estimated that strength was reduced by about 33 % at the time of investigation.

Source

Törmänen J.; Leskelä M. Failures in timber structures (in Finnish: Kantavien puurakenteiden vaurioselvitys, tutkimusraportti RTL 0021). University of Oulu, 1996

Case 93 – Curving of upper chord of roof truss, Hollola

Description of structure

This case is actually a set of 15 different similar cases (one in Hollola, two in Loimaa, three in Nurmijärvi, four in Oulu and five in Turku).

The structures in question were rectangular one span hall buildings constructed with wooden trusses.

Description of failure

In all these cases, the top chord of the truss was bent to a curved shaped (laterally) which could be seen from the tile roof setup. Actual collapses did not occur. The roofs were repaired by strengthening the top chords and bracing for roof and top chords was added.

Original investigation performed and conclusions

Investigation was made by a structural engineering student for his diploma work based on information received from designers and local authorities. His conclusions included:

The top chords were not supported laterally. No bracing design was done.

Source

Törmänen J.; Leskelä M. Failures in timber structures (in Finnish: Kantavien puurakenteiden vaurioselvitys, tutkimusraportti RTL 0021). University of Oulu, 1996

Case 94 - Damages in glulam beams, Laukaa

Description of structure

This building is a school gymnasium built in the 1970's with a length of 24 m and width of 13.4 m. The damaged glulam beam is supported on a concrete column. The beam cross section is $b \times h = 140 \times 800 \text{ mm}^2$, the span is 13.4 m and the beam spacing 2.4 m. The support connection of the beam and column is as shown in figure 94-1 below.

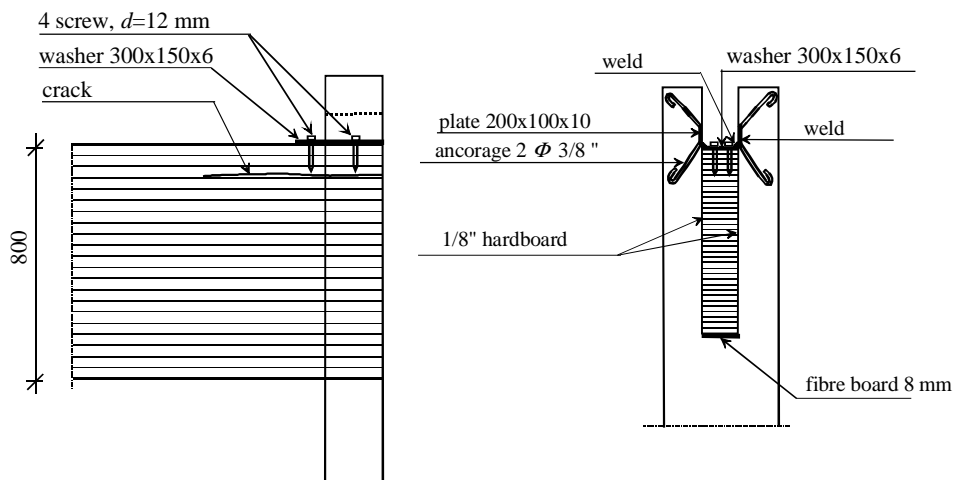

Figure 94-1: Support connection of glulam beam to concrete column.

Description of failure

On March 3rd, 2006, cracks were observed in the other end of the beams. The cracks were situated at the height of the screw ends in the section.

Original investigation performed and conclusions

This case was studied by the accident investigation board of Finland. The investigators visited the site on April 5th, 2006.

The snow load was 1.8 kN/m^2 when the failure was noticed. This load is equal to the characteristic snow load in the design standards for this region.

The reason of this failure was that the beam dried and shrunk during the heating season. The screws on the top prevented this shrinkage and in combination with the snow load the section cracked. There was no danger for collapse.

Additional conclusions and comments

Similar shrinkage failures have been observed in other sites as well. These have not lead to collapse, but cracks in glulam members.

Case 95 - Impending roof collapse, Keitele

Description of structure

A commercial building, originally 40 to 45 years old, had been enlarged twice. The damaged beam was part of the old building part next to the newer enlargement. The beam was as shown in figure 95-1 below, a single span plus a cantilever. The cross section was $b \times h = 92 \times 845 \text{ mm}^2$ and it was loaded from a 4 m wide tributary area. The other beams were loaded from a 3.8 m wide area. The beams were supported on concrete columns.

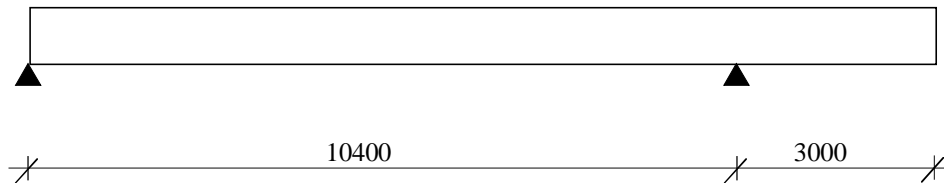

Figure 95-1: Beam in roof structure.

Description of failure

On April 7th, 2006 in the evening, when the market was still open, the beam started to deflect downwards. The beam was immediately supported at centre span and the snow load was removed before any further collapse could occur.

Original investigation performed and conclusions

This case was studied by the accident investigation board of Finland. The investigators visited the site on May 12th, 2006, when the additional supports were still in place and the damages on the beam could be seen. The damage was initiated at midspan, from a lower lamella scarf joint and this crack continued upwards with an inclined path.

The snow load at the instant was 1.3 kN/m^2 and the characteristic snow load is 2.0 kN/m^2 for this region. The maximum bending stress was 6.4 N/mm^2 at the time of failure.

The cause was a failure of the glued connection of the lamella scarf joint. This had failed in the glue line and not in the wood. The glue type was caseine glue, which has not been used in Finland for 35 years in load bearing glulam structures.

Additional conclusions and comments

In one other beam a scarf connection also had a crack. The beams had been filled and painted for visual reasons and cracks could be hidden. At the time of fabrication, lamella scarf joints were thought to be more reliable than finger joints.

Case 96 - Roof collapse of a Manege hall, Veteli

Description of structure

The hall was built in 1992 and it had 5 m high external load bearing wood element walls and a roof of nail plate trusses with 22 m span. The spacing of the trusses was 1.2 m and in the truss support a vertical timber frame member was always placed. The roof battens on top of the trusses were $h \times b = 32 \times 72 \text{ mm}^2$ with a spacing of 300 mm. The roofing was made with a profiled felt roof (Onduline-roofing). The length of the hall was 60 m.

Description of failure

The whole roof as well as one long external wall collapsed in the evening of April 8th, 2006. There were no witnesses. Social rooms and a cafeteria in the other end of the building did not collapse.

Original investigation performed and conclusions

This case was studied by the accident investigation board of Finland. The investigators visited the site on the april 12th, 2006 (before clean-up) and on april 20th, 2006 (after clean-up).

Three causes were found responsible for this failure. It is not known which of them is the prime reason:

- The internal compression members were lacking stability support although this was mentioned in the truss design.
- The lateral support of the truss top chord was lacking. The top chord was only braced by the profiled felt roofing (onduline), which is not sufficient.
- The lateral stability of the whole building was not satisfactorily. A diagonal bracing area of 3.6 m width below the trusses at the hall ends was installed, but these were unable to carry tensile loads in the wall direction.
- There was insufficient support for buckling of the timber studs in the load bearing walls. The resulting capacity was only 40 % of the required.

The snow load during the collapse was 1.3 kN/m^2 . The design was made for a snow load of 2.0 kN/m^2 .

Case 97 - Collapse of a Market roof, Haapajärvi

Description of structure

This market building was constructed in 1997. The roof was constructed with single pitch trusses which were supported on the external walls and on a beam line in the center of the building. This beam was a glulam beam supported on steel columns. The span of the trusses was 19.7 m.

Description of failure

The collapse was initiated on April 8th, 2006 at 8.35, when the roof deflected by 20 to 30 cm. The final collapse took place 1.5 hours after this. The roof came down at a 20 m distance from the front façade area. These happenings were witnessed and photos were taken.

Original investigation performed and conclusions

This case was studied by the accident investigation board of Finland. The investigators visited the site on the April 8th, 2006, before clean-up, and followed the clean-up later.

The cause of the collapse was that at one location the truss top chords were not stabilized at a 1600 mm length although in the design a roof batten spacing of maximum 300 mm is given. This area was at the entrance and at the cashiers where the roof had been lifted.

Case 98 – Glulam arched beams with notches

Description of structure

The structure consists of a number of glulam arched beams, 21.5 m in span. The building was erected during winter, and approximately one year after its inauguration, the failure occurred. During the erection of the beams, notches were cut to fit the support. The notches were approximately 160 mm deep, and the remaining depth at support approximately 500 mm. The cuts, which were done on site, thus correspond to about 24 % of the beam depth.

Description of failure

One of the arched beams was found to have a 7-8 m long crack, which seemed to originate from the notch at the support. The crack path followed the main fibre direction in the beam and only on short parts did it follow any bond line.

Original investigation performed and conclusions

An on-site inspection was performed by SP. At the inspection, two more beams were found to have similar cracks, although of considerably shorter length. In addition to this, bleeding from bond lines of the beams with the large crack was seen. The bleeding can indicate that a too low amount of hardener had been used. Apart from the inspection on site, the moisture content of the beams was determined, samples were also taken in form of drilled cores, and the type of failure at the drill locations was determined.

The investigation concluded that the failure was due to high stresses perpendicular to the grain at the notch. Since the crack had only followed the interlaminar bonds very locally, it was also concluded that the bond line strength had not been of any importance for the failure.

Additional conclusions and comments

The conclusions of the original investigation seem adequate. The failure can be classified as being due to bad practice on site (assuming that the notches were not in the original design), bad knowledge about design of notched beams (assuming the notches were included in the original design).

Case 99 – Failure of a roof beam at building site

Description of structure

The structure in this case was a roof beam, a double tapered beam with a span approximately 11 m. The beam depth was approximately 350 mm at the supports and 690 mm at mid-span. Two circular holes of diameter 300 mm were placed symmetrically, 500 mm from the mid-span. A schematic of the beam is shown below in figure 99-1.

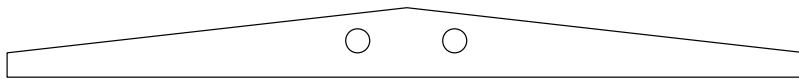

Figure 99-1. Schematic of the double tapered beam.

Description of failure

The failure occurred during construction of the building. The roof beams had been erected and covered with corrugated steel. Thermal insulation and roof decking materials were lifted up to the roof. The personnel on the building site had got instructions to place the material over the beams, and especially to place heavy pallets close to the support. Just as the first beam was covered with pallets, a sudden and catastrophic failure occurred. The beam fell to the ground.

Original investigation performed and conclusions

SP personnel made an on site inspection, and the failed beam was put together on the ground. The failure pattern is shown in the schematic of figure 99-2. The first 1.2 m of the crack denoted A in figure 99-2, ran in an interlaminar bond line, which was of very low quality. In the first 20 cm of crack A, measured from the support, only dried hardener was found. In the rest of the crack, glue was found on both surfaces, but the bond line was light coloured. This indicates that the amount of adhesive applied had been small. The amount of wood failure in crack A was also very small. The beam had been connected to the column by means of nailing plates. The plates were placed such that one row of nails split the bond line.

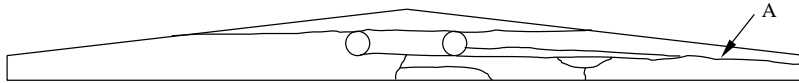

Figure 99-2. Failure pattern of the failed beam.

In addition to inspecting the failure surfaces, test samples were taken from the failed beam to perform delamination tests. The delamination was for all cases well below the stipulated margins according to ASTM 1101-59.

The conclusions of the original investigation were that the poor bond line acted as an initial crack, a situation that was worsened by the row of nails in it.

Additional conclusions and comments

The conclusions of the original investigation seem adequate. The failure can be classified as being due to poor manufacturing of the glulam. In addition to this, the nailing at the support worsened the situation, but a bond line of normal quality would not have been affected.

Case 100 – Cracks in roof beams with holes

Description of structure

The roof structure of the building consists of six double-tapered beams with a free span of 20 m placed at 6 m distance. The beam height was 765 mm at the supports and 1870 mm at the mid-span. Four of the beams had rectangular holes at the support. The holes were 146 mm deep and 400 mm wide, see figure 100-1.

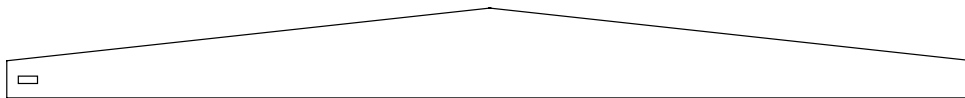

Figure 100-1. Schematic of roof beam with hole at the support

Description of failure

When replacing the lights in the building it was discovered that several large cracks had opened and an investigation by SP was commissioned.

Original investigation performed and conclusions

SP-personnel performed an on-site inspection. The beams were visually inspected and the moisture content of the beams was measured with a resistance meter. The beams with hole at the support had all cracks starting from the upper corner and running along the beam length. These cracks were from 65 to 750 mm long and 50-65 mm deep. One beam had cracks also at the lower corner of the hole, see figure 100-2.

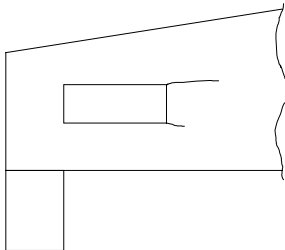

Figure 100-2. Schematic of cracks at hole.

In addition to the cracks at the support, two beams also showed considerable cracking at mid-span. One beam had a single 5 m long crack and one beam had two cracks 2 and 4 m long, respectively. The cracks were situated in the 10th bond line from the lower edge (5 and 4 m cracks) and at the 6th bond line from the lower edge of the beam (2 m crack). At the inspection it was also noted that the glulam was made from timber that in the outer parts of the beam did not fulfil the Nordic Glulam standard in terms of quality

(knot sizes). Several finger-joints also showed a poor quality in terms of distance from knots and in terms of gaps between the fingers.

The investigation concluded that the cracks in the beams were due to mechanical loading, due to poor design of the holes. It was recommended to reinforce the holes. It was also recommended that the moment capacity of the beams should be checked, taking into account the low quality of the timber used and the poor quality of the finger-joints.

Additional conclusions and comments

The conclusions of the original investigation seem adequate. The failure can be classified as being due to poor design of the beams, with inadequate consideration of the stress concentration at the holes. It is not known whether the holes were manufactured with the proper corner radii, neither whether the holes were made at the glulam manufacturer or on site. In addition to this, the poor quality of the glulam and finger-joints may have worsened the situation.

Case 101 – Delamination in roof beams

Description of structure

The structure is an old roof structure built with prismatic glulam beams. The year of erection is unknown, but probably the building was erected during the 1960:s. The building was extended in 1983.

Description of failure

In 1985 damages from water were found. The roof structure was inspected and extensive moisture induced damage was found, but also serious damage to the old glulam beams. The damage of the glulam beams led to extensive deflection of the beams, and since the damages increased rapidly in time, it was decided that the old roof beams would have to be replaced.

Original investigation performed and conclusions

SP was commissioned to perform an investigation to conclude the reason of the failure. An on site inspection was performed. The beams that had been replaced were inspected.

It was found that moist air was leaking from the new part of the building into the roof structure of the old part. When the moist air hit the cold parts of the structure it condensed. Free water was also found. Microscopy studies of the bond lines were performed. The moisture content in the beams was found to be between 15 and 26 %.

It was concluded that the old beams were manufactured with a cold-setting acid-curing adhesive. These types of adhesives were commonly used in the 1960s. In some cases it is possible that the acid from the adhesive is deposited if an excess of acid is available and if the bond line is subjected to high moisture contents. The acid in turn degrades the wood resulting, in time, in total loss of structural integrity.

Additional conclusions and comments

The conclusions of the original investigation seem adequate. The failure can be classified as being due to the use of an adhesive type that can be sensitive to high moisture contents. The failure is thus due to poor material in combination with building physics related issues. The cold setting type of adhesive used was banned about 40 years ago. In Sweden, approximately 150 buildings where this type of adhesive has been used for the glulam structure, have been identified and inspected.

Case 102 – Glulam purlins failure

Description of structure

This structure is a roof structure consisting of large double tapered glulam beams, with a secondary structure (purlins) also made from glulam. The purlins are 6 m long.

Description of failure

The failure occurred in early spring following a winter with heavy snowfall. The failure was a tensile bending failure in one of the purlins. The purlin did however not fall to the ground, but due to excessive deformation it acted in almost pure tension.

Original investigation performed and conclusions

At failure, a local consultant inspected the building. The consultant was contacted in 2004 and interviewed for further information not available in the original report. From the interview it was found that the snow load on the roof had been measured and was found to be approximately 400 kg/m². In addition to the snow there was about 5-10 cm of ice below the snow. The roof had a pitch of 14°, and the failed purlin was situated on the leeward side. The snow load had become extremely unsymmetrical, due to wind. At the roof top only a few centimetres of snow was found. The failure of the purlin seemed to be initiated at a finger-joint.

The failed beam was sent to SP for investigation. The failed finger joint was inspected. It was found that the failure had probably been initiated at a finger-joint in the outermost lamination, and a crack had propagated upwards through a joint in the second lamination. An intact finger-joint of the beam was tested in bending and was found to be of excellent quality. No indications were found of adhesive failures/poor gluing, rot or other biological degradation. The wood had good strength properties. The production journals of the manufacturer of the glulam were surveyed, and no irregularities were found. The conclusion was that the beam material, including finger-joints and interlaminar bonding had no part in the failure.

Additional conclusions and comments

The conclusions of the original investigation seem adequate. The failure was not caused by bad design or erroneous materials. From the additional information obtained in the interview it can instead be concluded that the failure was caused by the heavy loading on the roof. The local snow load on the most loaded part of the roof exceeded the design load according to the code, which at the time was 2.0 kN/m² (exceptional load case).

Case 103 – Failure in roof beam with notches

Description of structure

This structure was a large hall, with a roof consisting of double tapered beams, resting on columns and/or wall beams. At the support, notches had been cut and reinforced with bonded-in rods. The roof beams were 31.5 m in span, approximately 2 m deep at mid-span and 1100 mm deep at the supports. The notches cut at the support were 26 and 35 % of the beam depth respectively (calculated at the inner side of the notches). A schematic of the roof beam is shown in figure 103-1.



Figure 103-1. Schematic of roof beam (not to scale).

Description of failure

A sudden failure occurred, producing a loud noise, and resulting in a crack running from the corner of the notch at one of the supports, see figure 103-2. The crack was through the width of the beam, measuring 12 m on one side and 9 m on the other. Its initial width, or crack opening, was 50 mm. The vertical side of the notch was displaced approximately 15 mm. After the failure it was decided that immediate actions would have to be taken to reinforce the structure, since there was an imminent risk of total collapse. Temporary columns were placed underneath the roof beams, close to the supports.



Figure 103-2. Schematic of roof beam (not to scale).

Original investigation performed and conclusions

An extensive investigation of the building was performed by SP. The investigation included on site inspection, measurements of beam geometries, deflections and what was found to be initial deformations. Samples were also taken to test bond-line strength and moisture content.

A large number of more or less serious errors were found. Here only the most serious ones are reported.

The roof beams had been manufactured to a mid-span depth less than the final depth of the beam using traditional technique. After this, two additional laminations had been nail-glued to the beam in order to achieve the final depth. The nail-glued laminations were not end-joined at the apex.

At erection the roof beams had not been stabilised properly (or not at all) until all roof beams were put in place. This led to an initial deformation of the beams, which were leaning and also had a horizontal deflection. For one beam, the total horizontal deformation at mid-span was estimated to 110 mm.

The wind-stabilising trusses had not been properly post-tensioned, leading to a more or less non-active structure in terms of wind stabilisation.

The roof beams had been designed without accounting for the deformation of the wall beam. This led to non-uniform load sharing, thus roof beams resting on columns taking greater load than the roof beams resting on wall beams.

The design of the notches was inadequate. The formal shear stress at the support was approximately twice the design value. A separate fracture-mechanics based calculation made in the investigation, concluded that the average failure load was in the range of the actual load at failure. The failure load was estimated to approximately 120-140 kN shear force, and the actual load was estimated to 140 kN.

It was concluded in the investigation that the failure was caused by the high stresses perpendicular to the grain at the notch. The situation was worsened by many other factors, such as the initial deformation and the non-uniform load sharing of the roof beams, but it was estimated that the roof eventually would have failed irrespective of these anomalies.

Additional conclusions and comments

The conclusions of the original investigation seem adequate. The failure can be classified as being due to poor design of the beams, with inadequate consideration of the stress concentration at the notches. Even if the building code used at the time of design did not correctly handle the notched beam design, the code values of permitted stresses were exceeded.

Case 104 – Failure of a roof structure during erection

Description of structure

The roof structure of a complete building was assembled on the ground. The structure consisted of four trusses according to figure 104-1. The trusses were joined by purlins. No additional lateral bracing was present. The total span of the trusses was approximately 42 m and the spacing between the trusses was approximately 7.2 m.

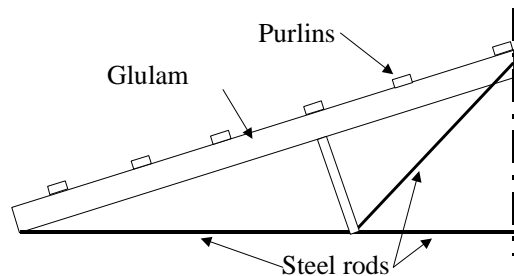

Figure 104-1. Combined glulam-tension rod truss (not to scale).

Description of failure

After finalising the roof structure with four trusses and purlins, a crane was used to raise it in place on top of supporting columns. The straps used during rising of the structure were placed according to figure 104-2. The forces in the straps lead to a compressive force in the glulam parts, as indicated below. In addition, the purlins are also subjected to compressive forces, see figure 104-3. Just before putting the roof structure down on its supports, the structure collapsed. According to witnesses, one of the outermost trusses tilted and the structure failed.

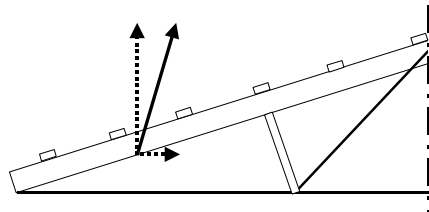

Figure 104-2. Strap placement.

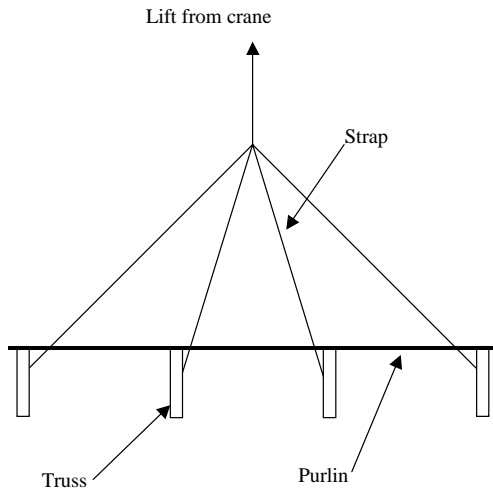

Figure 104-3. Strap placement.

Original investigation performed and conclusions

SP personnel conducted an inspection on site. The beams were investigated with regards to failure surfaces, amount of glue failure in finger joints, delaminations etc.

The conclusion from the original investigation was that buckling of the purlins caused the failure, due to an excessive compressive force being applied. A simple hand calculation of the forces was made showing that the normal force in the mostly stressed purlin exceeded the design value by a factor of 3. The positions of the straps during the lifting were possible to determine due to local compressive failure of the wood.

The investigation also showed that the glulam had several defects, including defect finger-joints. It was, however, concluded that these had no influence on the failure.

Additional conclusions and comments

The conclusions from the original investigation seem adequate. The failure can be classified as being due to poor handling during erection. The roof structure should have been further stabilised during the raising. The local crushing of the wood at the straps should alone be a reason for stopping the lifting operation.

Case 105 – Cracking in arch structure

Description of structure

The structure was built in 1934 and consists of six parallel arches, which act as statically indeterminate load-bearing frames. The arches have I-shaped cross-sections and web stiffeners at every 4 m. The flanges are held together with bolts going through the beam at the stiffeners. The structure was originally used as an outdoor theatre arena. In 1983 the building was subject to renovation and insulation was placed in the roof, in order to make the theatre an indoor facility. The insulation was placed in between the arches, not on top of the existing roof.

Description of failure

When additional restoration work was conducted in 1988, a large crack was found in one of the arches. No data on when the crack had developed was available. SP was commissioned to perform an investigation of the structure.

Original investigation performed and conclusions

An on-site inspection was performed. The crack that had led to the call for an inspection was measured, and is schematically shown in figure 105-1.

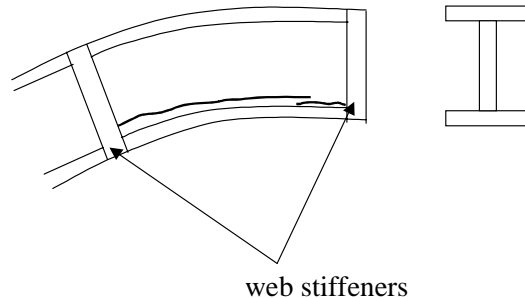

Figure 105-1. Schematic of arch apex with cracks. The crack length was about 4 m.

In addition to the cracks it was also noticed that the bolts holding the flanges together had loose fittings. Distances of about 5 mm were measured between the nuts and washers.

The original investigation concluded that the failure was due to the changing climate conditions after insulation was added to the roof. By placing the insulation in between the arches instead of on top of the existing roof, a temperature and thus a moisture gradient built up. The drying of the wood induced the perpendicular to grain failure.

Calculations showed that the loading by self-weight resulted in approximately 0.2 MPa perpendicular to grain stresses, which is about the allowable stress. The moisture gradient induced stresses were estimated to be also about 0.2 MPa, and thus the strength of the material was reached. The moisture variation was assumed to be linear over the beam depth, with a difference of 6% MC between the inner and outer parts of the arch.

Additional conclusions and comments

The conclusions from the original investigation seem adequate. The failure can be classified as being due to poor knowledge about moisture induced stresses in wood. This failure shows the importance of accounting for other loads than mechanical ones when designing load-bearing structures.

Case 106 – Cracks in glulam roof structure

Description of structure

This structure is a glulam roof structure, built in the early or mid 1960s. A schematic of the structure supporting the hipped roof is shown below in figure 107-1. The roof beams had support along the walls and in the middle of the building. At the supports indicated in figure 106-1 the beams had notches. The glulam beams marked A and B had cross-sections of 115 by 697 mm², the remaining beams had cross-sections of about 190 by 700 to 1000 mm².

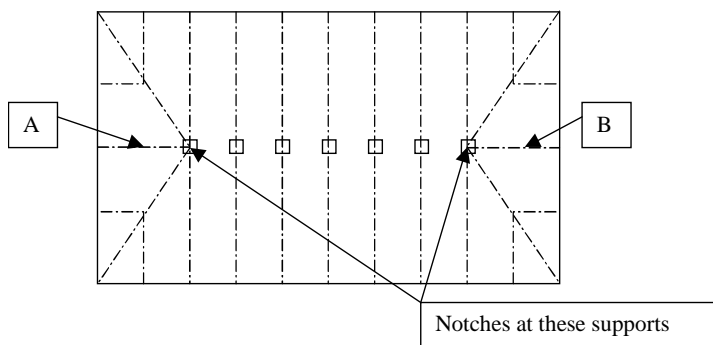

Figure 106-1. Schematic of roof structure

Description of failure

During winter beam A failed in shear, with a crack originating from the support where a notch had been cut. The crack originated from the mid-depth of the beam. The beam was lifted, a new steel support put in place and the beam was then reinforced with steel holders.

Original investigation performed and conclusions

Approximately one year after the failure the building was inspected by SP-personnel, who conducted a visual inspection, tested bond line strengths from drill cores (both from interlaminar bond lines and from finger-joints). The MC of the beams was measured using a resistance meter and was found to be below 11%. A metal detector was used to look for steel reinforcements, but no indication of such were found.

Several of the beams, apart from beam A that is, were found to be reinforced with steel hangers and in some cases with steel rods through the beams, fastened by nuts on either side of the beams. It is not known exactly when these reinforcements were made, but probably in the early 1970s. At that time, the beams had also been exposed to weather, being unprotected during the work.

The inspection showed that in beam A, the crack did originate from the notch at the support. Also beam B had a crack originating from the notch corner.

In total, 9 of the beams were inspected and were all found to have cracks. In some cases the cracks were severe, leading to delamination at the end of the outermost lamella. Another beam showed a combination of shear and tensile failure close to the support at the wall.

At the reinforcements by rods fastened with nuts it was clear that substantial drying deformations had occurred. The nuts were not tightly fixed to the wood surface.

The conclusions of the initial investigation do not mention anything about a probable cause of failure. It was concluded, however, that the damage was so severe that the beams at the gable should be replaced immediately.

Additional conclusions and comments

It is unclear exactly when all the beams had failed, except for beam A. The cause for the failures is most likely due to over-loading/bad design of the notches at the supports. The drying deformations found indicate that also drying stresses could have worsened the situation.

Case 107 – Failure in tapered glulam roof beam

Description of structure

The building was erected in 1963-64. The structure is a sports hall with 8 parallel glulam double tapered roof beams. The beam depth at mid span is approximately 1250 mm. About 1.5 m from the support, a 100 mm circular hole has been cut to provide space for tubes.

Description of failure

The investigation performed by SP personnel took place about 10 years after the failure, since the hall was to be renovated. There was a concern that the actions taken at the previous failure had not been adequate and also that the beams might have been manufactured using acid-hardening adhesive.

The failure, which was not investigated by SP, was detected since it made it impossible to use some of the gymnastics equipment. One of the roof beams had a crack approximately 200-300 mm from the lower side of the beam, starting from the support and reaching beyond mid-span. The failed beam was replaced, and four of the remaining beams were strengthened with plywood, partially or along the entire beam length. The plywood was screwed and glued to the beam sides.

Original investigation performed and conclusions

At the investigation performed by SP, as mentioned 10 years after the failure, moisture content, cracking, geometrical data, adhesive bond line tests and tests for sulphur content were performed.

The conclusions were that there was no reason to take any further actions relating to the adhesive bond line quality, and that the adhesives used were not based on acid hardening systems.

It was suggested that the holes made at the supports were to be further investigated for possible cracking, since these parts of the beams were not possible to inspect at that time.

Additional conclusions and comments

Data regarding geometry is lacking. However, it is not unlikely that the failure can be due to the holes at the support.

Case 108 – Cracking in tapered glulam roof beams

Description of structure

The building is a sports hall, erected in 1988. The roof structure consists of seven double tapered roof beams, approximately 655 mm deep at the supports and 1300 mm deep at mid-span. The beam width is 185 mm. The beams have a span of approximately 20 m, and are placed with a spacing of 5 m. The roof is made from self-supporting corrugated steel sheets.

Description of failure

At a building inspection it was noticed that extensive cracking had occurred in several beams. This led the inspecting consultant to recommend an extended inspection to be performed by SP.

Original investigation performed and conclusions

The beams are visible from the inside of the building and were inspected by SP personnel. Apart from geometrical data of the beams the moisture content was measured, and found to be in all cases below 10%. The beams were manufactured with a dark coloured adhesive. All beams were inspected for cracking, although not all parts of all beams were inspected. The parts inspected were selected amongst those parts showing the most severe cracking, as was visible from the floor level. This means that the parts not inspected are likely to have less severe cracking.

The original investigation gives a rather detailed view of the cracks. The conclusions were that, apart from drying cracks which are normal in glulam, there were about 10 cracks 1-8 m long and 30-70 mm deep, which could not be explained by drying alone. The most severe crack of these was one starting at the support and reaching about 6-7 m, running all the way in an interlaminar bond line. This crack was found on both sides of the beam, and on one side it had been filled with adhesive at the production. The crack depth was measured to be more than 70 mm on one side and at least 10 mm on the other side (the depth of the repair was 10 mm). In several cracks there was evidence that the adhesive had started to cure too much before appropriate pressure had been applied.

The conclusion was that the severe cracks were due to manufacturing errors (too long open assembly time), and that the shear capacity of the beams should be re-evaluated, taking into account the crack depths and lengths.

Additional conclusions and comments

The conclusions from the original investigation seem adequate. The failure can be classified as being due to manufacturing error, related to a too long open assembly time.

Case 109 – Failure in beams at steel connections

Description of structure

The roof structure of this library and lecture hall consists of primary load bearing glulam beams of depth between 855 and 1350 mm. The beam width is 215 mm. The beams are connected at supports with a steel connector, schematically shown in figure 109-1. The structure was erected during March – April.

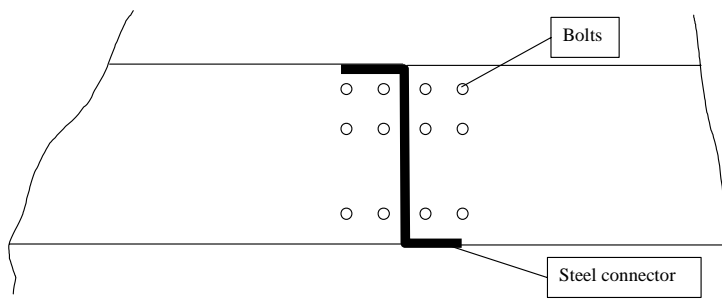

Figure 109-1. Schematic of beam connection.

Description of failure

Approximately six months after the completion of the roof structure, severe cracking occurred in the connections, see figure 109-2. Another four months after this, in February, a shear failure in one of the beams occurred. The failed beam had been monitored prior to the shear failure, and it was concluded that its deflection had increased from 37 mm to 121 mm under constant loading conditions, from December to February.

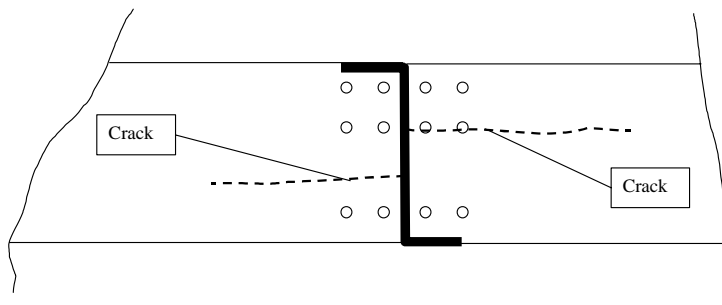

Figure 109-2. Schematic of beam connection and cracks found.

Original investigation performed and conclusions

The original investigation made by SP personnel included two inspections on site. The inspections included measurements of crack depths, beam geometrical data and moisture contents at different depths.

The moisture content in the beam was found to vary from approximately 9% at the surface to 10% in the inner parts of the beam 530 mm from the connection, and to approximately 12% at beam mid span.

The conclusion of the original investigation was that the failure was due to a poor connection design. The steel parts had been fitted without taking into account possible moisture induced deformations, leading to cracking when the beams dried. The moisture content at delivery to the site was probably in the range of 10-12%, as was confirmed by the protocol from the internal control of the manufacturer. The investigation concluded that the shrinkage was equivalent to an 8% reduction in moisture content (from approx. 18 to 10%). If this is correct, the only possible explanation is poor handling of the beams during construction. Although the beams were delivered with plastic covers, it is still likely that the ends of the beams have been subjected to water at the connections. Being fitted in a state of high moisture content, the subsequent drying lead to the cracks since the connection design does not allow for any deformation.

Additional conclusions and comments

The conclusions from the original investigation seem adequate. The failure can be classified as being due to poor design of the connections, not taking into account the moisture induced deformations of the wood material. The handling of the beams at the building site also played a role here.

It is unclear if the connection design would have caused the same problems if the beams had been handled correctly, and drying from 10-12% moisture content to approximately 7% at the wood surface. Whatever the case, this type of rigid connection should be avoided.

Case 110 – Cracks in glulam arches

Description of structure

The structure is an arched glulam roof structure. The 36 arches are supported on the exterior concrete walls of the building with steel hangers. Although visible from the inside of the building, the arches are difficult to inspect. The arches are made from 30 to 31 mm thick laminations, 187 mm wide. The beam depth varies.

Description of failure

One and a half to two years after construction cracks in the arches were discovered. These led to the inspection of the building.

Original investigation performed and conclusions

The arches were inspected with regards to geometry, moisture content and cracks. The moisture content of the arches was 11-12% at the surface and 12-13% 30 mm below the surface. Six arches were inspected. Cracks with lengths up to almost half the span were found. The description of the structure, its steel hangers and crack locations is difficult to follow. However, it seems like all cracks investigated had started from the supporting hangers or close to these.

The investigation concluded that several cracks were due to weakened bond lines. The bond lines were probably weakened due to premature hardening of the adhesive and/or due to insufficient pressure during curing.

Additional conclusions and comments

The conclusions from the original investigation seem adequate. The failure can be classified as being due to weakened bond lines in the glulam emanating from production errors, such as premature hardening of the adhesive and inadequate pressure.

Since the exact design of the structure and especially the design of the hangers is unknown it is difficult to draw any other conclusions. One could suspect that if the arches were rigidly attached to the hangers, the cracking could be due to restrained shrinking of the glulam.

Case 111 – Cracks in glulam beams and columns

Description of structure

The structure is the main load bearing part of a sports hall. It was erected in 1985-86. The roof structure consists of 6 straight glulam beams with rectangular cross-section, supported by rectangular glulam columns. The beam cross-section was 140 by 450 mm and the columns were 140 by 405 mm. The columns supporting the beams were of different height, resulting in a roof pitch of 1:4. The beams were slightly tapered at the lower support, reducing their depth. At the upper support there was a notch cut, approximately 100 mm deep.

Description of failure

No information is available regarding the reason for the inspection, but obviously there was a general concern of the integrity of the structure, which had numerous cracks.

Original investigation performed and conclusions

The inspection included geometrical data, moisture content measurements and measurements of the cracks.

The beams had some cracks in both the bond lines and in the laminations. The length of the cracks was approximately 1.5 m, the crack depths were not measured.

The columns had rather severe cracking, on all sides. Crack depths of up to 71 mm were measured. Traces of surface treatment (paint or lacquer) were found in most of the cracks.

The connection of the wind stabilising structure (probably steel rods) showed a gap between washer and nut of 4 mm.

At the upper beam support (the one with the notch) a gap of 2-4 mm was found between the column and the beam. There were no signs of crushing of the wood material perpendicular to the grain at the supports. In 5 of the beams cracks were found. The cracks started from the notch and ran in the direction of the notch (along the beam axis). The largest notch crack was found to be 740 mm long with a depth of up to 75 mm.

It was concluded that the cracks in the columns were due to moisture-induced deformations. The gap between washer and nut was taken as evidence for this. Consequently, it was concluded that the moisture content in the columns had been as high as 15% at construction. These cracks were not judged as being likely to cause any structural degradation. It was recommended that the cracking of the columns should be monitored in the future.

It was furthermore concluded that the cracks in the beams with notches was due to stress concentrations in the notch. It was recommended to perform new design calculations for the notches and possibly to reinforce them using glued-in rods, to avoid that the cracks would grow further.

Additional conclusions and comments

Although difficult to make a detailed analysis of this case, due to lack of information, the conclusions of the original investigation seem adequate. The failure was due to poor design of the notched support. The cracks in the columns are not to be regarded as a failure, since these were not so severe so as to cause any structural degradation.

Case 112 – Delamination in glulam beams

Description of structure

This structure is a roof structure of an ice-hall. The structure is a three-hinged roof truss with a tensile rod as depicted in figure 112-1. A total of 11 roof trusses at a spacing of 6 m make up a total of 60 metres length of the building. The building was erected in 1964.

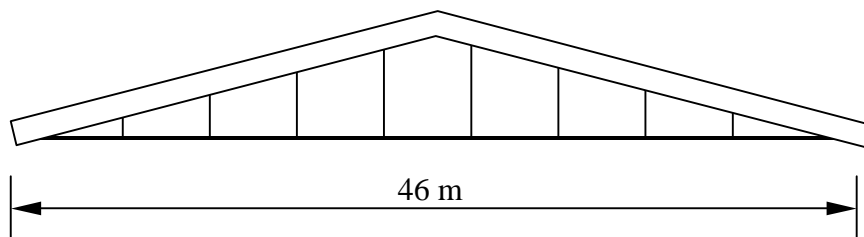

Figure 112-1. Roof structure.

Each of the 190 mm wide roof beams was made up from two laminations, edgewise glued to each other. The two laminations had widths of 45 and 145 mm respectively. This is shown in figure 112-2.

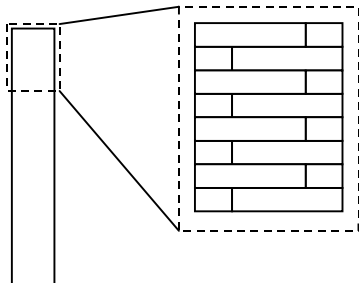

Figure 112-2. Beam cross-section built up from edgewise glued laminations.

Description of failure

After two summers of severe moisture conditions in the hall, extensive delamination was seen in three of the trusses. Being built in 1964, the structure had been inspected for the possible occurrence of acid hardening adhesives. No such adhesive could be detected.

Original investigation performed and conclusions

The beams were inspected on site and were photographed. The delamination depth was measured and drilling core samples were taken for shear testing and chemical analysis.

The original investigation concluded that the two beams that had been damaged were different from the others. During the inspection information was provided indicating that a failure had occurred during the erection of the building. This would explain that two of the trusses were different.

The failure was concluded to be due to the moist conditions, which had lead to the severe delamination. It was concluded that the laminations had probably not been edgewise glued together and planed before forming the beam cross-section. Instead it is likely that the laminations had been put in place all at once, to form the cross-section. This means that even a very small difference in lamination thickness between the 45 and 145 mm laminations will result in the gluing pressure only being adequate for parts of the interlaminar bond line.

It was concluded that the beams had not been glued with acid hardening adhesive.

The delamination had lead to a reduction of the active beam cross-section to about half the original. As a result it was recommended that these beams should be reinforced immediately.

Additional conclusions and comments

The conclusions from the original investigation seem adequate. The failure can be classified as being due to weakened bond lines in the glulam emanating from production errors, leading to an inadequate gluing pressure.

Case 113 – Collapse of roof structure in a school

Description of structure

The roof structure of the school building was made from single tapered beams, made from solid wood flanges glued to a plywood web. The flanges were glued-nailed to the web using a phenol or possibly a phenol-resorcinol adhesive. The flanges consisted of two timber members, one glued to each side of the web. The web had joints, which were reinforced by vertical wood members, also glued-nailed to the web. The flanges were also lengthwise joined by glued-nailed, overlapping wood members. The flange joint was located at the same section for both timber members in the flange. The roof beam is schematically depicted in figure 113-1. The span of the roof beams was approximately 7.9 m.

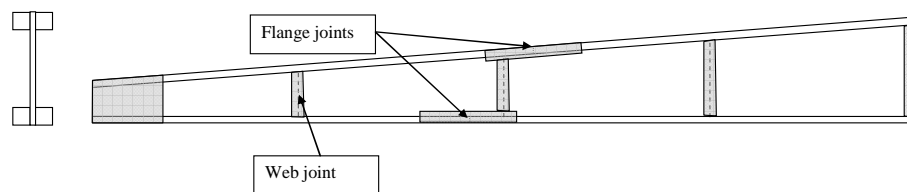

Figure 113-1. Beam with joint reinforcements.

Description of failure

In early spring, fortunately on a Sunday afternoon, all nine roof beams collapsed. The failure was complete and all beams had fallen down, failing at mid-span.

At the collapse, the snow load on the roof was high. The snow depth was measured the same day and was found to be between 56 and 65 cm. The snow density was also measured this day, and was found to be approximately 300 kg/m^3 , and thus the snow load was equivalent to about 1.8 kN/m^2 .

Original investigation performed and conclusions

Approximately two weeks after the failure, SP personnel performed an on-site inspection of the building. Apart from obtaining geometrical data of the beams, the failure modes and the quality of the bond lines were investigated.

The conclusions of the investigation performed were that the failure had started as a tensile failure in the lower flanges. This in turn was initiated due to the overlap joints of the flanges being of poor quality. It turned out that the production of the beams was done

by applying adhesive on only one surface, and that no pressure was applied apart from the pressure from the nails. Using only the nails for obtaining glue pressure is surely not enough, since large areas in between nails do not experience any considerable pressure.

As an example of the poor overlap joints, in one beam the active bond line area was estimated to be only about 10% of the theoretical one. In other beams the bond line between the flange and the web was also poor, with up to one metre long parts without any adhesive on one part of the joint.

Additional conclusions and comments

The conclusions from the original investigation seem adequate. The failure can be classified as being due to poor production methods when manufacturing the beams.

Case 114 – Buckling of roof structure

Description of structure

A large number of similar structures were built in Sweden for a chain of stores. The structure is based on nail-plate connected roof trusses, see figure 114-1. The battens, for support of the roof tiles, are nailed directly to the upper chord of the roof trusses. The roof structure also includes a reinforced plastic sheeting or a hard fibre board, covering the roof trusses, for draining of rain water. At least 26 cases have been documented, where the same principle was used for the load bearing structure. The buildings are relatively large, with free spans of 20-25 m and lengths of up to 65-70 m.

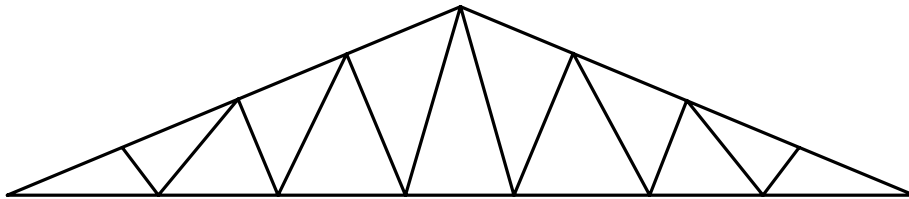

Figure 114-1. Example of roof truss

Sometimes, the trusses have been manufactured in two parts, for transportability, see figure 114-2.

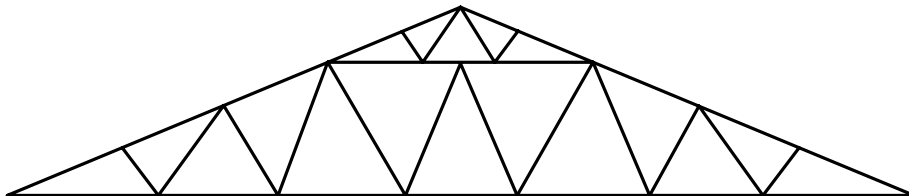

Figure 114-2. Truss divided in two parts for transportability.

Description of failure

In at least four cases similar failures have been observed (several failures have been reported, including one in Norway and one in the Czech republic). The failure was due to lateral displacements in the compressed parts of the truss, deformations were measured in one case to be as large as 400-500 mm, see figure 114-3.

The failure led to the battens falling down in between the roof trusses in several cases. The battens were often joined at the same truss, leading to a more flexible structure with

larger deformations. It is noticeable that there was no snow on the roof when failure occurred.

The risk of total collapse of the buildings was estimated as being very high in some of the cases.



Figure 114-3. Example of deformations at failure.

Original investigation performed and conclusions

Several investigations have been performed on the current buildings, the first in 2003. Although the problem was known at that time, new buildings were constructed the following years. In 2005 SP wrote a formal letter of warning to Boverket. This resulted in a commission to perform an overall investigation of all known failure cases and the reasons for these and also a more general investigation of how this large amount of buildings with potentially unsafe design could have been erected without any reactions from building authorities.

The primary cause of failure is that the compressed parts of the trusses have been lacking lateral constraints to avoid buckling. The nailed battens do not provide enough rigid connections to avoid buckling due to initial deformations. As an example, consider the design rules of EC5, where an edge distance of $15d$ to end grain and $7d$ otherwise is required. From this it is clear that the truss should have a thickness of $44d$ ($=190$ mm for $4,3$ mm nails), which should be compared with the actual width of 45 mm (in some cases 70 mm width was used for the truss). In conclusion, there is no possibility of transferring large tensile forces in the battens in order to stabilise the trusses.

An important question is how this large amount of buildings could have been erected with such poor designs. The investigation performed at SP concluded that:

- There exists a lack of knowledge among Swedish timber engineers relating to basic design of timber structures.
- The education of timber engineers has been neglected.

- There is a need for *complete* design examples for Swedish engineers. The Swedish code, BKR, contains only partial descriptions. Complete examples exist in a Swedish translation of the ENV-version of EC5, but this is probably not well-known by practising engineers, since the use of EC5 is not well established.
- The building process is highly diversified, with a large number of subcontractors taking responsibility only of their part. Thus, the stability of the trusses tends to fall in between different areas of responsibility.
- Price is more driving than quality.

The internal control, which is supposed to stop this kind of poor designs is not working properly.

Additional conclusions and comments

The conclusions from the original investigation seem adequate. The failure can be classified as being due to poor design.

Case 115 – Cracking in glulam frame

Description of structure

This structure is a tennis hall built from 3-hinged glulam frames, placed at 9 m distance. The columns are curved, and attached to the ground by steel parts, see figure 115-1.



Figure 115-1. Arched column with steel parts (in white).



Figure 115-2. Crack at column fitting to the steel part.

Description of failure

One of the columns showed a large crack, which stopped at a length of 2-2.5 m, figure 115-2. The crack started from the steel part, where a notch had been made. The hall was closed pending an investigation and proper actions to be taken.

Original investigation performed and conclusions

The day after the cracking, representatives from the glulam manufacturer visited the hall. From the inspection it was concluded that:

- The amount of snow on the roof was less than 200 mm.
- No deformations nor misalignments were visible.
- The crack was approximately 10 mm wide and 2-2.5 m long. The crack had gone through the complete beam width. The crack path crosses three laminations.

- The crack starts at a notch made for the steel part added to transfer horizontal loads.
- The steel part is not according to the original drawings. The steel part was placed about 100 mm from its original position, and a notch making this possible has been cut.
- There is evidence of leakage from the roof (miscoloring of the glulam). Thus, a possible moistening of the timber followed by drying could be the reason for crack formation.

To assure that no further cracking would occur, and as a temporary remedy, steel fixings were placed on the column, at the crack end, see figure 115-3.



Figure 115-3. Temporary steel fixings attached to the column.

Additional conclusions and comments

The conclusions from the original investigation seem adequate. The failure can be classified as being due to alterations on site and due to poor maintenance of the building.

Case 116 – Collapse during erection

Description of structure

A farm building with dimensions 12 m x 48 m was built as a timber-frame system.

Description of failure

During erection in 1994, the building collapsed.

Original investigation performed and conclusions

The investigation revealed that the collapse was caused by missing bracing. The bracing had not been installed yet, which resulted in buckling of the timber elements.

Additional conclusions and comments

The building was built without the instructions of a structural engineer.

Case 117 – Bending failure in finger jointed timber

Description of structure

An industrial building was erected in 1995 with a structure of concrete columns and beams. Purlins of finger jointed timber were used in the roof structure.

Description of failure

In 2000, after 5 years of use, a bending failure occurred in the finger jointed timber.

Original investigation performed and conclusions

The investigation showed that the failure was caused by unexpected loading. On the roof, a sawdust cyclone was installed. This cyclone had a leakage and rainwater filled the sawdust and froze when temperature dropped below zero. At the time of failure, a load of more than 10 kN/m^2 was present on the roof, which has to be compared to the design snow load of 2.5 kN/m^2 .

This failure was caused by unexpected loading due to flaws in maintenance.

Case 118 – Bending failure in eaves purlin

Description of structure

An industrial building was built as a large-scale glulam structure in 1975.

Description of failure

In 1984, the eaves purlin failed in bending.

Original investigation performed and conclusions

The investigation showed that the snow load on the roof moved downwards due to the pitch of the roof and melting. Extremely high snow load was present at the eaves, see figure 118-1, which led to overloading of the eaves purlin.

Additional conclusions and comments

Snow overhanging according to EC1 fig. 6.2 should have been considered.

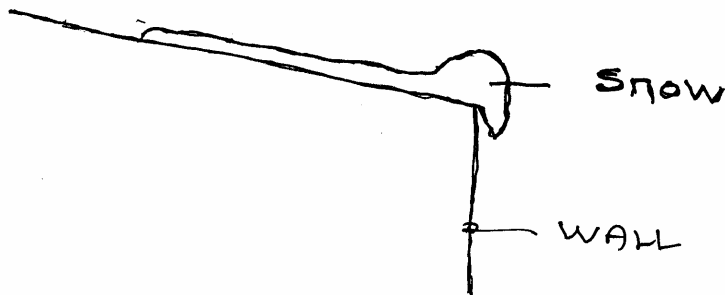

Figure 118-1: Snow load at time of failure.

Case 119 – Failure of wall due to high snow load

Description of structure

In 1988, an industrial building was built as a large-scale glulam structure.

Description of failure

In winter of 1991, the walls were damaged by snow, as is indicated in figure 119-1.

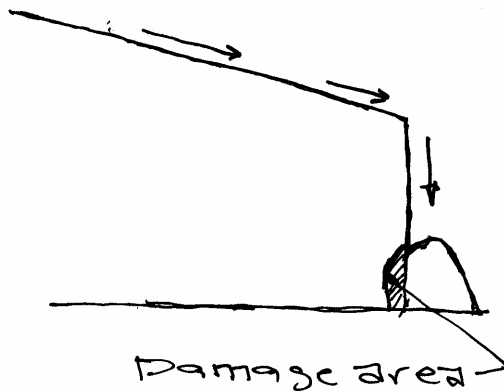

Figure 119-1: Snow load at time of failure.

Original investigation performed and conclusions

The investigation revealed that the snow load present on the roof had been gliding down the inclined roof and had accumulated onto the ground, piling up against the wall. This led to failure of the wall, due to unexpected lateral loading.

Additional conclusions and comments

In snowy regions as e.g. the alps, large roof overhang is commonly used to prevent this type of failure.

Case 120 – Tension failure in roof structure

Description of structure

In 2003, a farm building with mono-pitched roof was built with columns, beams and purlins, all made of glulam.

Description of failure

In 2003, tension failure occurred in the concrete anchorage of the columns and the roof came very near to collapse. Temporary supports were installed immediately.

Original investigation performed and conclusions

The investigation showed that the static model used in the design was very different from that realized in the as-built structure. The model assumed in design as well as the as-built structural system are shown in figure 120-1. The design was made under the assumption that the building should be braced at the roof level, figure 120-1a, but no bracing was provided at this level. The columns were designed as pin-jointed in both ends. Just after erection the system became unstable and moment failure occurred at the lower support of the short column.

The failure was caused by use of wrong structural model in the design, which was made with a computer program which automatically generated the structural model. The designer did not realise that the generated model was valid only under the assumption that wind bracing should be arranged at the roof level.

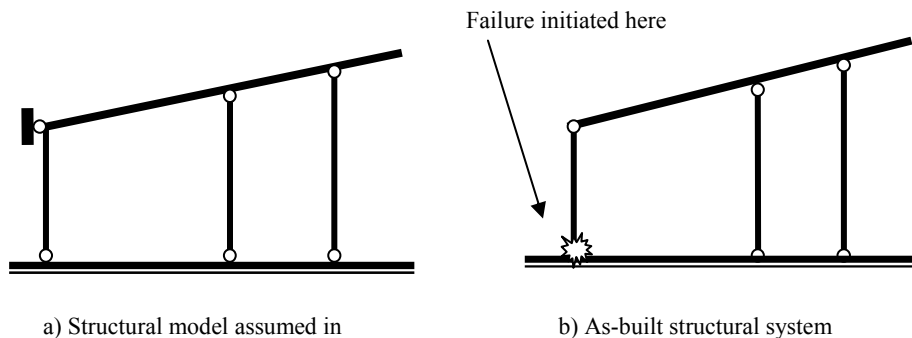

Figure 120-1: Assumed and real structural systems

Additional conclusions and comments

This is an example of design error, where the designer performed an automated computer analysis without understanding the conceptual behaviour of the structure.

Case 121 – Buckling in light-weight beams

Description of structure

A farm building (11 m x 24 m) was built in 1973 with light-weight plywood beams and timber columns. The beams had a depth of 630 mm and were placed at 3.5 m centres. The plywood web was butt jointed, see figure 121-1.

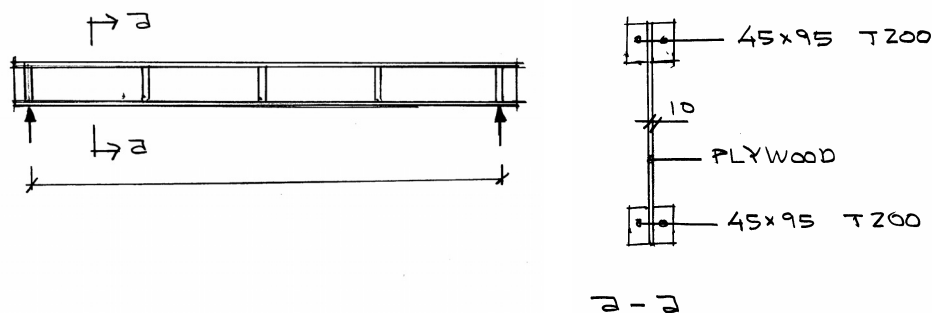

Figure 121-1: Light-weight I-beams.

Description of failure

In 2000, a web buckling failure occurred in all beams at about 1.5 to 2 m from the support near a butt joint. The beams collapsed and fell down. At the time of failure, a snow depth of 95 cm was present on the roof.

Original investigation performed and conclusions

One cause of failure was inadequate buckling resistance of the web, probably due to the weakness imposed by the web joint. Another cause could be overload from snow. The roof was designed for a snow load on ground equal to 1.5 kN/m^2 , while the snow load at the time of failure was estimated to $2.2\text{-}2.3 \text{ kN/m}^2$. This is probably the reason why the failure occurred after as long time as 27 years.

Case 122 – Anchorage failure in glued joint

Description of structure

A school building was built in 1998 with a glulam structure as shown in figure 122-1, using glulam columns and single tapered beams. The spacing between the beams is 6 m. The beams are connected at the ridge by a glued connection with slotted-in steel plates, see figure 122-2.

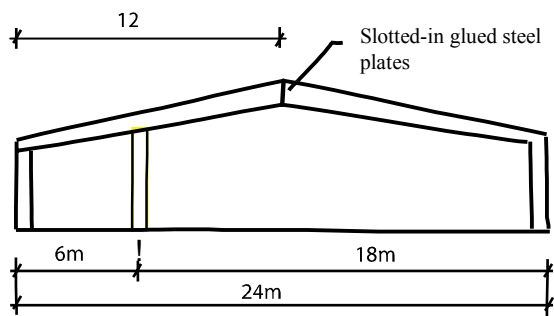

Figure 122-1: Glulam structure.

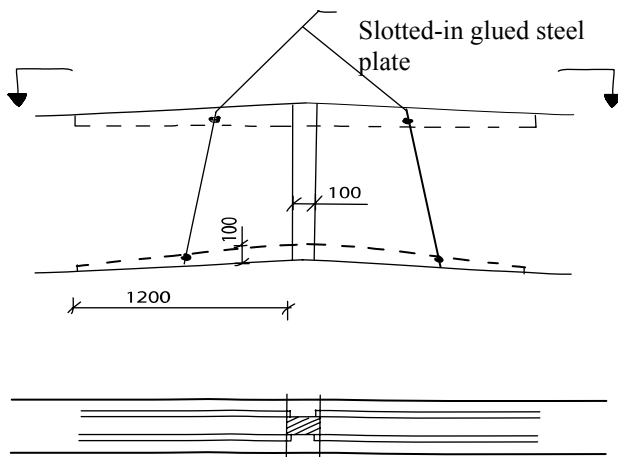

Figure 122-2: Glued connection at the ridge, using slotted-in steel plates.

Description of failure

In 2002, anchorage failure occurred in the glued joint.

Original investigation performed and conclusions

The investigation revealed that the glued joint was not appropriate for this structure. Moisture induced deformations are not allowed due to the restraining effect of the glued-in steel plates. Moreover, the quality of the glueline was bad.

At the time of failure, the moisture content in the timber was 10%.

Overloading can be excluded as a failure cause as no snow load was present at the time of failure, but the structure is designed for a snow load of 2 kN/m².

Additional conclusions and comments

This failure is caused by a combination of disregard of environmental actions (restrained shrinkage) and poor principles during erection (poor quality of bond line).

Case 123 – Plug-shear failure in noise barrier joint

Description of structure

In 2004, a noise barrier was built with fixed-base glulam columns. The columns were spaced 3.5 meters and were 4.4 m high.

Description of failure

The noise barrier collapsed during a storm in January 2005.

Original investigation performed and conclusions

The investigation showed that the bolted joints had been poorly designed. Wood failure occurred in the joints, which were loaded in shear, leading to block-shear failure.

This failure is due to flaws in mechanical design.

Case 124 – Collapse of a glulam-pyramid

Description of structure

In 2005, a glass-glulam pyramid was built according to figure 124-1 below, spanning across 20 m.

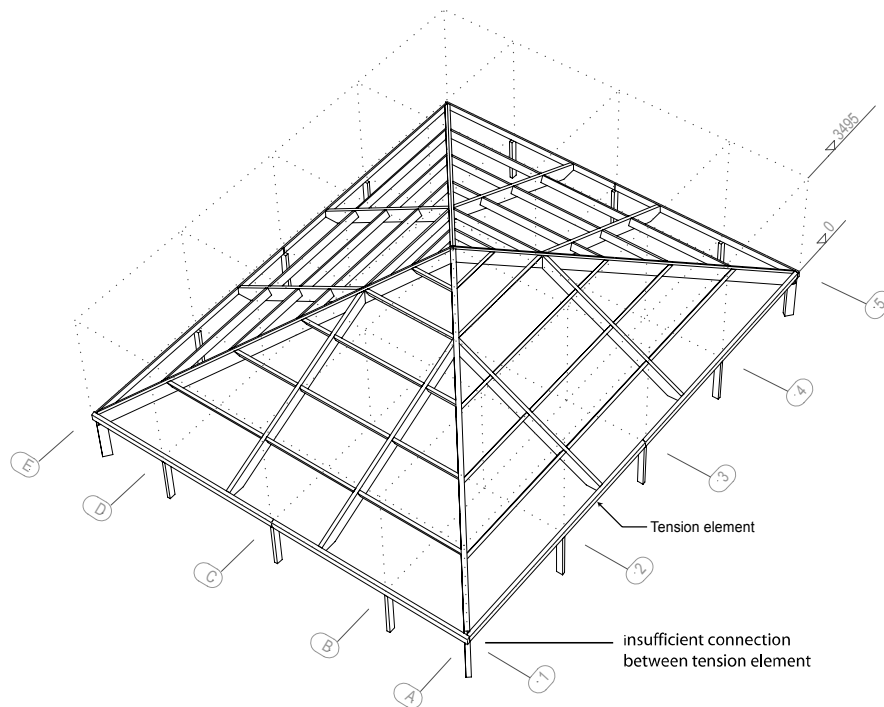

Figure 124-1: Pyramid structure, built with glulam and glass.

Description of failure

During erection, the complete structure collapsed.

Original investigation performed and conclusions

The investigation revealed poor design of the connection of the tension elements, resulting in poor bracing. Shear failure occurred in the joints.

This collapse is mainly caused by poor mechanical design.

Case 125 – Collapse of industrial building during construction

Description of structure

In 2005, an industrial building was built with a span of 26 m and a length of 72 m. The load-bearing structure consists of glulam beams and columns, see figure 125-1.

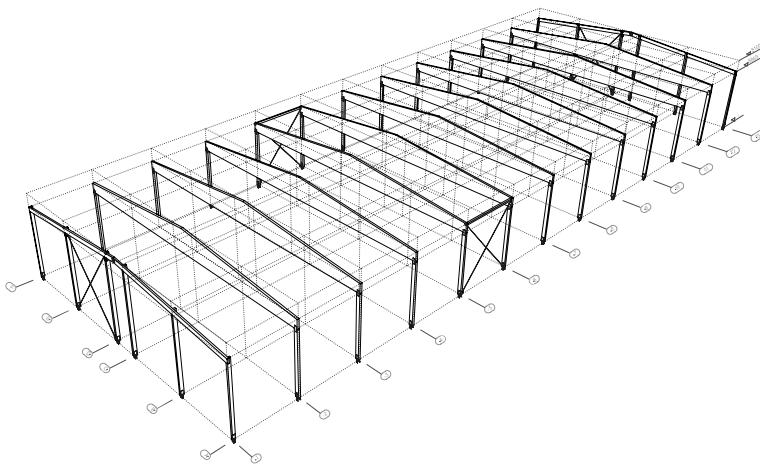

Figure 125-1: Industrial building with glulam beams and columns.

Description of failure

During construction, the complete structure collapsed.

Original investigation performed and conclusions

The investigation revealed that the collapse was caused by poor principles during erection. The joints between beams and columns had been executed with only one outer steel plate, which led to lateral failure when the wind came from “the wrong direction”, see figure 125-2.

Lateral instability due to insufficient bracing led to collapse of the system.

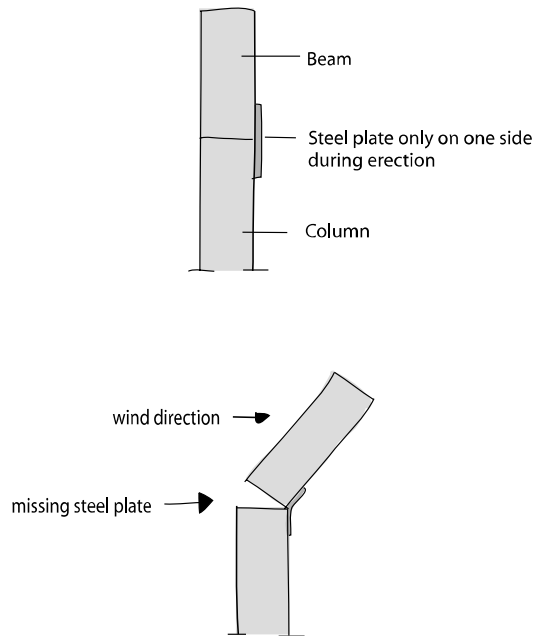

Figure 125-2: Joint between columns and beams. Left: joint as executed, right: failed joint.

Case 126 – Cracking in double-tapered glulam beam

Description of structure

A shopping centre was built in 1973-74 with double-tapered glulam beams oriented downwards, as shown in figure 126-1.

Description of failure

In March 2006, severe cracking occurred in one of the glulam beams, with a risk of the lower part of the beam being torn off, see figure 126-2.

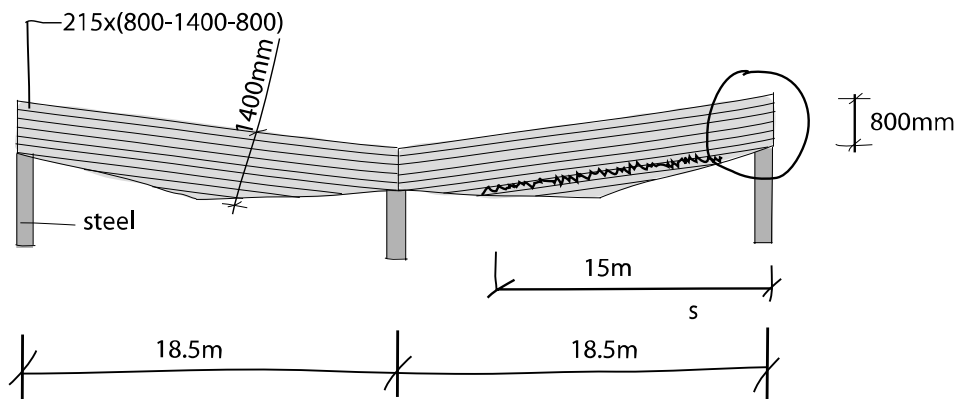

Figure 126-1: Roof structure in shopping center with double-tapered beams oriented downwards. Jagged line indicates cracking.

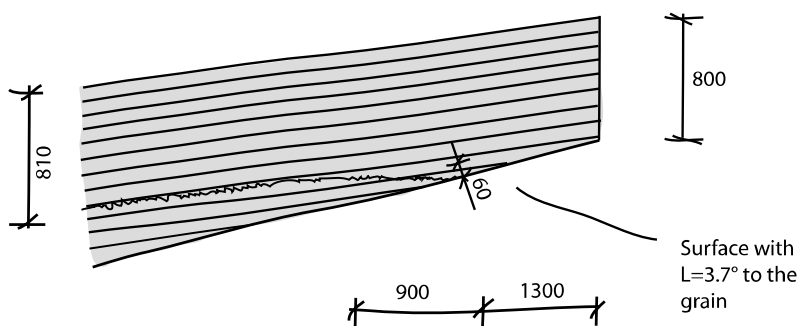

Figure 126-2: Detail view of double-tapered beam (near right support). Jagged line indicates cracking.

Original investigation performed and conclusions

The investigation showed that the snow load at the time of failure was only 0.7 kN/m^2 , which is much lower than the design snow load of 2.5 kN/m^2 . The moisture content in the structure was 6.5 %. Drying cracks could be observed on the tension side of the beam.

Stresses present in the structure were calculated to $\sigma_t = 4.1 \text{ MPa}$, $\tau = 0.6 \text{ MPa}$ and $\sigma_{t90} = 0.01 \text{ MPa}$.

The original design has been done according to the Swedish code SBN1967 and no design error was found.

The investigation is still going on.

Case 127 – Timber failure in glulam beam

Description of structure

A timber storage was built in 2004 using a structure with glulam beams and glulam columns, see figure 127-1. The building is open on the gable side. The roof overhang on the gable is 3 m. The roof is covered with a sheet steel plates.

Description of failure

In a large wind storm on January 8th, 2005, the first beam (at the gable) failed. Timber failure occurred and the beam was torn apart, with the upper part (and parts of the roof) flying away, see figures 127-1 and 127-2.

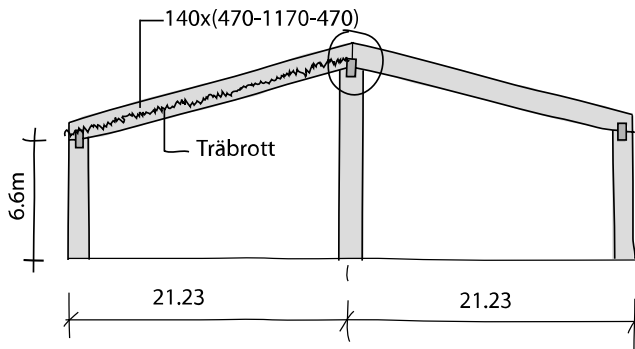

Figure 127-1: Storage building with glulam columns and glulam beams. Jagged line indicates timber failure.

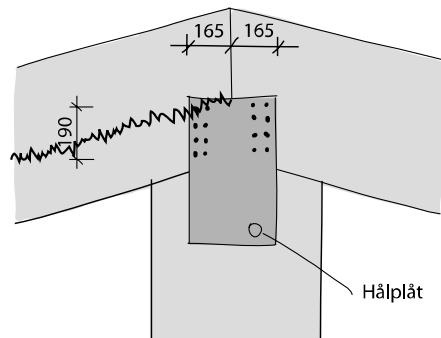

Figure 127-2: Detail of joint between beam and column at the centre of the building. Jagged line indicates timber failure.

Original investigation performed and conclusions

The investigation showed that the failure was caused by flaws in the joint between column and beam, see figure 127-2. Tension failure perpendicular to the grain occurred in line with the topmost row of nails.

Additional conclusions and comments

The roof beams are poorly designed. Using the design loads, bending stresses of 33 MPa occur.

Furthermore, the joint between beam and column is poorly designed. Block shear occurs at a load level of 55% of the design load.

The bracing was assigned to the roof sheathing. However, the steel sheathing is exposed to large temperature variations during the year. For example, at 36°C air temperature, the plate will have a temperature of 65°C, and at -32°C, it will attain the surrounding temperature. This results in a temperature difference of 97°C, which leads to a movement in the steel plate of $\delta = 1.2 \cdot 10^{-5} \cdot 97 \cdot 21800\text{mm} = 25\text{mm}$, which makes the steel roof unsuitable for stabilization.