



LUND UNIVERSITY

Galectin-8 specificity to cells: from broad outside to fine inside

Nordenfelt, Susanne

2007

[Link to publication](#)

Citation for published version (APA):

Nordenfelt, S. (2007). *Galectin-8 specificity to cells: from broad outside to fine inside*. [Doctoral Thesis (compilation), Division of Microbiology, Immunology and Glycobiology - MIG]. Institution of Laboratory Medicine, Section of Microbiology, Immunology and Glycobiology (MIG).

Total number of authors:

1

General rights

Unless other specific re-use rights are stated the following general rights apply:

Copyright and moral rights for the publications made accessible in the public portal are retained by the authors and/or other copyright owners and it is a condition of accessing publications that users recognise and abide by the legal requirements associated with these rights.

- Users may download and print one copy of any publication from the public portal for the purpose of private study or research.
- You may not further distribute the material or use it for any profit-making activity or commercial gain
- You may freely distribute the URL identifying the publication in the public portal

Read more about Creative commons licenses: <https://creativecommons.org/licenses/>

Take down policy

If you believe that this document breaches copyright please contact us providing details, and we will remove access to the work immediately and investigate your claim.

LUND UNIVERSITY

PO Box 117
221 00 Lund
+46 46-222 00 00

Från Institutionen för Laboratoriemedicin, Avdelningen för mikrobiologi,
immunologi och glykobiologi, Lunds Universitet

Galectin-8 specificity to cells

From broad outside to fine inside

Av

Susanne Carlsson



LUNDS
UNIVERSITET
Medicinska fakulteten

Akademisk avhandling

Som med vederbörligt tillstånd av Medicinska Fakulteten vid Lunds Universitet för avläggande av doktorexamen i medicinsk vetenskap, ämnesområde molekyllär medicin, kommer att offentligen försvaras i

Rune Grubb-salen, Biomedicinskt Centrum, Sölvegatan 23,
lördagen den 26 maj 2007, kl 09.00

Handledare: Hakon Leffler

Fakultetsopponent: Docent Jan Holgersson, Avdelningen för klinisk immunologi, Karolinska Universitetssjukhuset, Huddinge, Sverige

Organization LUND UNIVERSITY		Document name DOCTORAL DISSERTATION
Institute of Laboratory Medicine Department of Microbiology, Immunology and Glycobiology (MIG)		Date of issue 2007-05-02
		Sponsoring organization
Author(s) Susanne Carlsson		
Title and subtitle Galectin-8 specificity to cells: from broad outside to fine inside		
<p>Abstract</p> <p>Glycobiology is the world of sugars: how they are made, what they look like, and what they do. Despite the importance of glycan structures in life, knowledge has been hampered due to their inherent complexity. Lectins are nature's way to decipher the intricate code held by glycans, which makes them important players in both normal and pathological physiology. A key to the understanding of lectins and their cellular effects lies in the basis of their carbohydrate specificity and the multivalent interactions occurring at a cell surface. Also in the design and synthesis of new drugs, either to be used as future tools in fruitful glycobiology experiments, or as effective therapeutics in the clinic, such information is very helpful.</p> <p>This thesis is aimed at investigating the fine specificity of the two carbohydrate recognition domains of a human lectin, galectin-8, and to relate this fine specificity with cell surface binding and induced cellular effects. In short, our experiments charted the individual ligand preference displayed by the two domains, in addition to explaining how the striking monovalent affinity for sialylated β-galactosides, shown by the N-terminal domain, was achieved. Further, we showed that although cell surface binding of intact galectin-8 didn't require the sialic acid binding ability of the N-terminal domain, intracellular targeting following endocytosis did.</p>		
Key words: Galectin, CRD, Fine Specificity, Sialic acid, Endocytosis, Intracellular targeting		
Classification system and/or index terms (if any):		
Supplementary bibliographical information:		Language English
ISSN and key title: 1652-8220		ISBN 978-91-85559-72-5
Recipient's notes	Number of pages 132	Price
	Security classification	

Distribution by (name and address)

I, the undersigned, being the copyright owner of the abstract of the above-mentioned dissertation, hereby grant to all reference sources permission to publish and disseminate the abstract of the above-mentioned dissertation.

Signature Susanne Carlsson

Date 2007-04-12

GALECTIN-8 SPECIFICITY TO CELLS

-FROM BROAD OUTSIDE TO FINE INSIDE

SUSANNE CARLSSON

SECTION OF MICROBIOLOGY, IMMUNOLOGY AND GLYCOBIOLOGY (MIG)



LUND
UNIVERSITY
Faculty of Medicine

© **Susanne Carlsson**

ISSN 1652-8220

ISBN 978-91-85559-72-5

Lund University, Faculty of Medicine Doctoral Dissertation Series 2007:94

Printed by Media-Tryck, 2007

*The beginning of knowledge is the discovery
of something we do not understand*

Frank Herbert

Table of contents

TABLE OF CONTENTS	7
LIST OF PAPERS	9
ABBREVIATIONS	10
INTRODUCTION TO THE COMPLEX WORLD OF GLYCOBIOLOGY	11
GLYCOWHAT?	11
N-LINKED GLYCANS	12
O-LINKED GLYCANS	15
GLYCOSAMINOGLYCANS	16
GLYCOLIPIDS	16
GPI-ANCHORS	17
DECIPHERING THE GLYCO CODE	17
GALECTINS – A LITTLE HERE, A LITTLE THERE	19
WHAT IS A GALECTIN?	19
GALECTIN STRUCTURE	19
POST-TRANSLATIONAL MODIFICATIONS, SUBCELLULAR DISTRIBUTION, AND NON-CLASSICAL SECRETION	21
MULTIVALENCY AND OLIGOMERIZATION	21
GALECTIN FUNCTION	22
GALECTIN-8	24
<i>Discovery of galectin-8</i>	24
<i>Galectin-8 isoforms</i>	24
<i>Galectin-8 expression in normal tissues and cancer</i>	25
<i>Galectin-8 in adhesion of cells</i>	26
<i>Galectin-8 in cell growth and apoptosis</i>	27
<i>Galectin-8 modulates neutrophil migration and function</i>	28
OBJECTIVES	29
GALECTIN-CARBOHYDRATE INTERACTIONS	30
SPECIFICITY – A KEY TO BIOLOGICAL FUNCTION	30
FRONTAL AFFINITY CHROMATOGRAPHY	30
ENZYME LINKED LECTIN ASSAY AND SURFACE PLASMON RESONANCE	32
FLUORESCENCE POLARIZATION	33

GLYCAN ARRAY	35
OTHER ASSAYS	36
GALECTIN FINE SPECIFICITY IS BUILT BY WEAK INTERACTIONS TO MULTIPLE SUBSITES	36
GALECTIN-8 BINDING LIGANDS ON A SURFACE.....	37
SPECIFICITY OF INTACT GALECTIN-8 IN SOLUTION VS. AT A SURFACE	38
FINE SPECIFICITY IN CELL SURFACE BINDING	39
MULTIVALENCY MAY ENHANCE AFFINITY OF LECTINS.....	39
GALECTIN-8 AFFINITY TO A CELL SURFACE	39
CHO CELL MUTANTS, TOOLS IN DETERMINING SPECIFICITY TO CELLS.....	40
PARENTAL CHO GLYCOSYLATION	41
GALECTIN-8 FINE SPECIFICITY IS NOT REQUIRED FOR BINDING TO CELL SURFACES.....	42
CELLULAR EFFECTS OF PROTEIN-CARBOHYDRATE INTERACTIONS	45
NO ALTERED ACTIVATION OF NEUTROPHILS BY G8S Q47A.....	45
ENDOCYTOSIS.....	46
<i>Membrane ruffles and macropinocytosis</i>	47
<i>Clathrin-mediated endocytosis</i>	47
<i>Membrane rafts</i>	48
<i>Caveolae and endocytosis</i>	49
<i>Clathrin- and caveolae-independent endocytosis</i>	50
FINE SPECIFICITY OF GALECTIN-8 DETERMINES INTRACELLULAR TARGETING	51
CONCLUDING REMARKS.....	53
POPULÄRVETENSKAPLIG SAMMANFATTNING PÅ SVENSKA	58
ACKNOWLEDGEMENTS	61
REFERENCES	63
APPENDICES: PAPERS I-III	73

List of Papers

This thesis is based on the following original papers, which will be referred to by their roman numerals.

- I. **Susanne Carlsson**, Christopher T. Öberg, Michael C. Carlsson, Anders Sundin, Ulf J. Nilsson, David Smith, Richard D. Cummings, Jenny Almkvist, Anna Karlsson and Hakon Leffler. Affinity of galectin-8 and its carbohydrate recognition domains for ligands in solution and at the cell surface. *Glycobiology* in press
- II. Santosh Kumar Patnaik, Barry Potvin, **Susanne Carlsson**, David Sturm, Hakon Leffler and Pamela Stanley. Complex *N*-glycans are the major ligands for galectin-1, -3, and -8 on Chinese Hamster Ovary cells. *Glycobiology* **16**:305-317 (2006)
- III. **Susanne Carlsson**, Michael C. Carlsson and Hakon Leffler. Intracellular sorting of galectin-8 based on carbohydrate fine specificity. *Glycobiology*, accepted pending minor revision

Papers I and II are published with permission from Oxford Journals.

Peer-reviewed papers not included in this thesis:

Aplander K, Tejler J, Toftered J, **Carlsson S**, Kahl-Knutson B, Sundin A, Leffler H and Nilsson UJ. Synthesis of a 3'-naphthamido-LacNAc fluorescein conjugate with high selectivity and affinity for galectin-3. *Carbohydrate Res.* **341**:1363-1369 (2006)

Cumpstey I, **Carlsson S**, Leffler H and Nilsson UJ. Synthesis of a phenyl thio-beta-D-galactopyranoside library from 1,5-difluoro-2,4-dinitrobenzene: discovery of efficient and selective monosaccharide inhibitors of galectin-7. *Org Mol Biol.* **3**:1922-1932 (2006)

Leffler H, **Carlsson S**, Hedlund M, Qian Y and Poirier F. Introduction to galectins. *Glycoconj J.* **19**:433-440 (2004)

Öberg CT, **Carlsson S**, Fillion E, Leffler H and Nilsson UJ. Efficient and expedient two-step pyranose-retaining fluorescein conjugation of complex reducing oligosaccharides: galectin oligosaccharide specificity studies in a fluorescence polarization assay. *Bioconjug Chem.* **14**:1289-1297 (2003)

Abbreviations

Aa	Amino acid
CHO	Chinese hamster ovary
CLIC	Clathrin independent carrier
CME	Clathrin mediated endocytosis
CRD	Carbohydrate recognition domain
EGF	Epidermal growth factor
FP	Fluorescence polarization
G8C	Galectin-8 C-CRD
G8N	Galectin-8 N-CRD
G8L	Galectin-8, long linker
G8S	Galectin-8, short linker
GAG	Glycosaminoglycan
Gal	Galactose
GalNAc	N-acetylgalactosamine
Glc	Glucose
GlcA	Glucuronic acid
GlcNAc	N-acetylglucosamine
IdoA	Iduronic acid
K_d	Dissociation constant
Lac	Lactose (Gal β ₁₋₄ Glc)
LacNAc	N-acetyl-lactosamine (Gal β ₁₋₄ GlcNAc)
Lacto-N-biose	Gal β ₁₋₃ GlcNAc
LNnT	Lacto-N-neotetraose (Gal β ₁₋₄ GlcNAc β ₁₋₃ Gal β ₁₋₄ Glc)
Man	Mannose
SA	Sialic acid
3'SA-Lac	Neu5Ac α ₂₋₃ Gal β ₁₋₄ Glc
T-antigen	Gal β ₁₋₃ GalNAc
TGF β	Transforming growth factor β
Wt	Wild type

Introduction to the complex world of glycobiology

Glycowhat?

To most people, sugars (carbohydrates) are primarily something energy rich in the diet, or, something you have to control when having diabetes. But besides being a part of energy metabolism, carbohydrates are, together with DNA, proteins, and lipids, one of the four biopolymers of which all living cells are constituted. Of the four, carbohydrates are the most abundant and most complex [1-3]. Glycobiology is the study of chemistry, structure, biosynthesis, biology and function of carbohydrates and their derivatives [2, 3]. Their complexity arises from enormous structural variability and a non-template driven synthesis.

Carbohydrate building blocks, monosaccharides, can be connected in either α - or β -linkage between any carbon atoms with a free hydroxyl group [3]. In addition, one monosaccharide can be linked to several other monosaccharides, creating branched structures which vastly increase the number of alternative configurations of a polysaccharide. Linearly connecting three given nucleotides or amino acids results in a maximum of six different trinucleotides or tripeptides, whereas three given monosaccharides can generate thousands of unique trisaccharides [3]. By further monosaccharide additions, the theoretical number of variants quickly reaches far beyond one million. Fortunately, in nature the number of combinations is limited.

Carbohydrates, or glycans, are built on protein or lipids by the combined action of sequentially working enzymes adding a monosaccharide in a specific linkage (glycosyltransferases) or hydrolyzing a specific linkage (glycosidases) [1, 3]. Almost all of these enzymes are found in the secretory pathway of ER/Golgi and as a result, most glycoconjugates are found on the outside of the cells or inside vesicles. However, also nuclear and cytosolic glycosylations, such as O-GlcNAcylation of proteins, play important roles in cell function [4, 5].

There is no obvious template after which glycosylation occurs, but still this process is highly regulated [1, 2]. Which glycans that can be produced in a cell is determined by the array of enzymes (glycosyltransferases, glycosidases and

others) present in that particular cell, and is a highly dynamic process. With the tight connection to cell metabolism, a cell's glycan repertoire is altered under various normal cell stages, e.g. during differentiation, and disease such as neoplastic transformation [6].

A protein with defined glycosylation sites does not necessarily get glycosylated exactly the same every time it's produced by a cell. Differences in which sites get glycosylated and the exact structure of the glycan give rise to various glycoforms, which can be of functional importance [7]. Such microheterogeneity could be an explicit example of precise regulation, or a stochastic event, or a little of both [1, 3]. The precise mechanisms that determine cell glycosylation remains to be understood.

Five different classes of glycans will be shortly described below, and their connection to human disease if applicable. Linkage of the glycan to its carrier, and its core structure, are structurally different and determines to which class the glycan is belonging [3], see also Figure 1.

N-linked glycans

Nearly all proteins that pass the endoplasmic reticulum and Golgi apparatus during their synthesis are glycosylated on one or more asparagines (Asn, N) (Figure 1). A lipid linked precursor oligosaccharide starts to assemble in the cytosol and is further extended in the endoplasmic reticulum (ER). When consisting of 14 monosaccharides in specific arrangement (2 GlcNAc, 9 mannose (Man) and 3 glucose units) it is transferred to an asparagine, often situated in an Asn-X-Ser/Thr motif, on a protein being translated nearby. Further processing to a 'high mannose' structure (2 GlcNAc and 8 Man) occurs before transit to the Golgi apparatus where trimming continues and GlcNAc is added, introducing a branch on the α 1-3 linked Man (giving rise to 'hybrid' type structures). This is required for the formation of so called 'complex' N-glycans that have one or more additional GlcNAc initiated branches on the α 1-3 and α 1-6 Man (Figure 1). The GlcNAc branches are usually elongated further by galactose, fucose and sialic acids [3, 8]. Longer glycan chains often contain repeating LacNAc (Gal β 1-4GlcNAc β 1-3) residues with terminal modifications as α 2-3 sialylation and/or α 1-2 fucosylation. A core fucosylation (on the GlcNAc linked to the protein asparagine) is also commonly seen. For a detailed review of the enzymatic steps forming the 'high-mannose', 'hybrid' and finally the 'complex' structures of the N-glycosylation process please refer to [8].

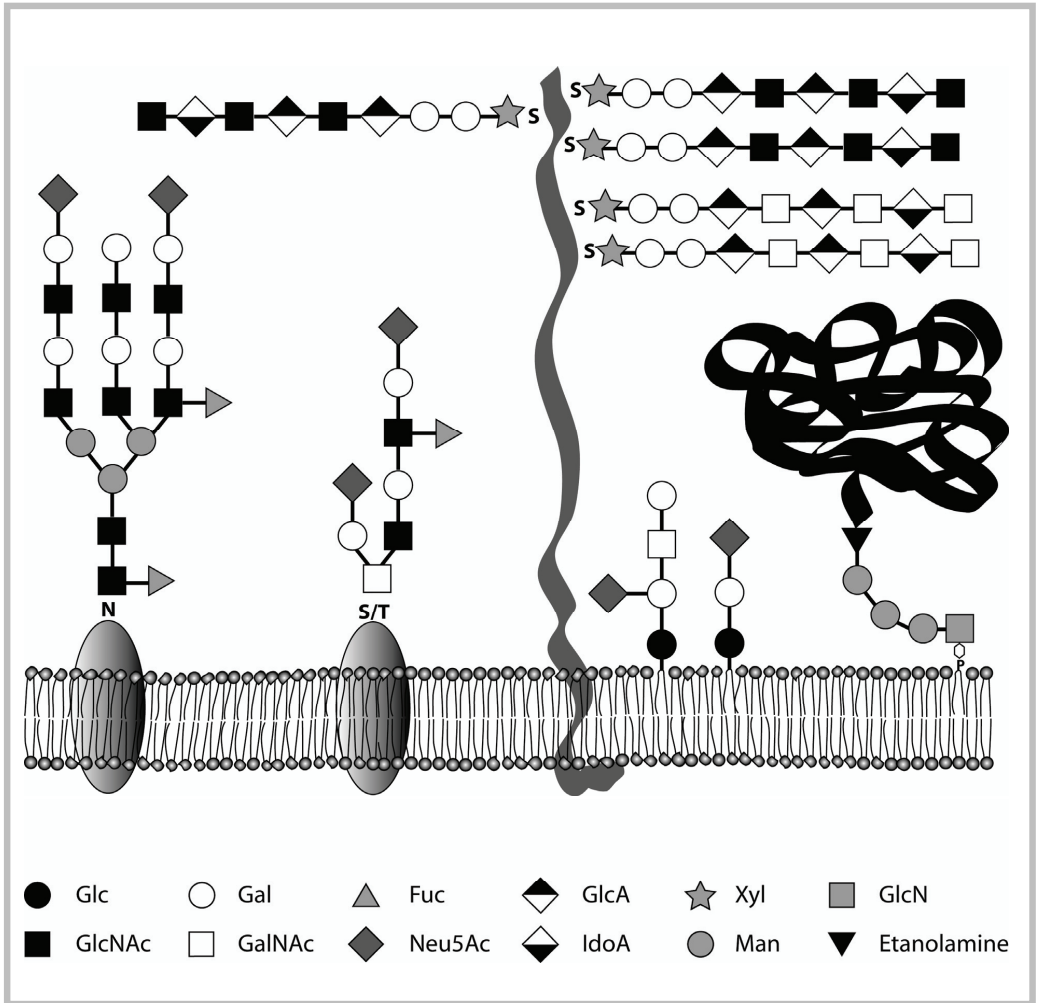

Figure 1 Glycoconjugates. Representative examples of each of the five classes of glycoconjugates (from left): N-linked glycan, O-linked glycan, glycosaminoglycans, glycolipids and a GPI-anchored protein. Monosaccharides are denoted by symbols (see legend) and are connected to each other in either α or β -linkage. The glycan structures on glycoproteins (N- and O-linked), glycosaminoglycans and glycolipids can be simpler or more complex than the ones shown. The O-glycan depicted has an extended core 2 structure. The proteoglycan is decorated with three heparan sulfate chains (top) and two chondroitin sulfate chains (bottom), sulfations are omitted for simplicity. The two glycolipids are GM1 (left) and GM3 (right) respectively.

An intermediate carbohydrate structure early in the N-glycan synthesis, participate in ER quality control of protein folding. Two glucose residues are removed from the pre-assembled 14-saccharide N-glycan and the remaining one-glucose glycan binds the membrane-bound chaperone calnexin (or its soluble homolog calreticulin). If correctly folded, the glucosidase II (GII) removes the last glucose (of the three present in the original 14-mer) and the protein exits ER and proceeds to the Golgi apparatus. If not correctly folded, after de-glucosylation by GII, the protein is recognized by the folding sensitive UDP-Glucose:glycoprotein glucotransferase (UGT) and gets re-glucosidated, whereafter it can re-associate with calnexin [9].

Most functions of N-glycans are, however, mediated after leaving the secretory pathway, where they can promote or hinder interactions between different molecules, and are thus implicated in the pivotal cell-cell communication and cell-matrix interactions that complex systems, such as organs and organisms, depend upon [2, 3]. By knocking out the *Mgat1* gene in mouse, synthesis of all complex N-glycans are aborted since its gene product, GlcNAc-transferase I, is responsible for the addition of the first GlcNAc branch in 'hybrid' type structures, which is absolutely required for the following enzymatic steps leading to complex N-glycans. The *Mgat1*^{-/-} mice die during early embryonic development and show defects in neural tube formation, vascularization and left-right asymmetry of the body [10, 11]. In contrast to the dramatic effect in mice, the *Lec1* mutant of Chinese hamster ovary (CHO) cells lacking a functional *Mgat1* homologue grows normally in cell culture [12]. Apparently, complex N-glycans are not essential for cell viability whereas they are of utmost importance in biological systems. Thus, experiments on cells in culture greatly contribute to the understanding of some aspects of glycobiology, but not others.

The largest number of genetic defects in glycosylation leading to human disease involves N-linked glycosylation pathways, with most affected patients (currently around 600) being diagnosed with a congenital disorder of glycosylation, or CDG [13]. In CDG patients, hypoglycosylation (too few or altered N-glycans on proteins) leads to a variety of symptoms affecting multiple organ systems. Type I CDGs have a defect in the assembly or transfer of the lipid-linked oligosaccharide precursor, which leads to unoccupied glycosylation sites on multiple proteins. A patient with typical symptoms of CDG-Ia, the most prevalent subtype of the CDGs, display severe psychomotor retardation, seizures, underdeveloped brain and defect blood coagulation [14]. Although it might be assumed that all CDG-I patients display similar phenotypes, this is not the case and genotype-phenotype correlations are still elusive. Type II CDGs involve defects in processing of the glycan after transfer to the protein acceptor, e.g. fucosylation (CDG-IIc) and sialylation (CDG-IIf). Other disorders that are not CDGs affect only specific pathways or cell types, including e.g. mistargeting of lysosomal enzymes (in mucopolipidosis II and III) and dysfunctional erythropoiesis (in congenital dyserythropoietic anemia, CDA II). A few

successful CDG-like mouse models exist, although null mutations of several of the involved glycosylation enzymes lead to death early in development [13]. This means that the CDGs are probably not due to complete enzyme deficits, because such children would never have been born, but is rather partial.

Recent findings suggest that gain-of-glycosylation, i.e. glycosylation on novel N-glycosylation sites caused by point mutations, might explain the pathological findings seen in up to 1.4% of pathogenic missense mutations listed in a human gene mutation database. For example, such a mutation was shown responsible for the loss of function of the IFN γ R2 in patients with increased susceptibility to mycobacterial infections [15].

O-linked glycans

Protein glycosylation can also occur by covalent linkage of a GalNAc to the hydroxyl group containing amino acids serine or threonine (Figure 1). To this first monosaccharide a galactose is added in β 1-3 linkage creating the core 1 structure, Gal β 1-3GalNAc (T-antigen), which can be further sialylated (but nothing more). For addition of core 2 (an additional GlcNAc β 1-6 branch on the Ser/Thr-coupled GalNAc residue), the unmodified core 1 is required. Core 2 can be elongated in mono- or biantennary form, and contains often repeating units of polylactosamines with terminal fucose and sialic acid. Similarly, addition of GlcNAc β 1-3 to the GalNAc on Ser/Thr (instead of the core 1 structure) generates core 3, and an additional GlcNAc β 1-6 (which resulted in core 2 when added to the core 1 structure) is termed core 4. Both core 3 and core 4 can be elongated and branched as described for core 2 [1, 3]. Core 2 is the most common in O-glycosylation, but less prevalent structures such as core 5-7 etc. have been observed [3].

O-glycans are present on many proteins, and sometimes in very large amounts. This is the case with the highly glycosylated mucins, important as protective barrier and lubricant e.g. throughout the gastrointestinal tract [16]. Another important function ascribed to O-glycans is the selectin dependent extravasation of blood leukocytes, where binding to sialyl Lewis^x epitopes terminally located on core 2-branches are central in the interaction between neutrophils and endothelial cells (reviewed in [17]). Further, the main clinical features of disorders like CDG-IIc, with increased number of circulatory leukocytes, and CGD-IIf, with giant and too few platelets in addition to a lower number of neutrophils, are more likely caused by the absence of fucose and sialic acid residues respectively on O-glycans rather than on N-glycans [13].

Other monosaccharides can also be O-linked to Ser/Thr such as GlcNAc (as in GlcNAcylation of nuclear and cytoplasmic proteins [5]), xylose (which will be described below for glycosaminoglycans), fucose (in regulation of Notch signaling [18]) and mannose [19]. O-mannosylation is important in development of brain, nerves and muscle tissue and genetic disorders include muscular dystrophies caused by lack of O-glycosylation of the muscle protein α -dystroglycan (e.g. muscle-eye-brain disease, Walker-Warberg syndrome) [20].

Glycosaminoglycans

Glycosaminoglycans (GAGs) are linear chains of repeating disaccharides, often highly sulfated, where the commonly used term proteoglycan refers to GAG chains (of one or several types) attached to a protein (Figure 1). Synthesis of all GAGs is characterized by chain initiation, polymerization and modification. All three of **heparan sulfate/heparin** (with a repeating GlcNAc-GlcA), **chondroitin sulfate** (GalNAc-GlcA) and **dermatan sulfate** (GalNAc-IdoA) are linked to proteins via an O-linked xylose on Ser/Thr, while **keratan sulfate** (a sulfated polylactosamine chain) is either O-linked (via GalNAc) or N-linked (via asparagine). Proteoglycans with chondroitin sulfate and dermatan sulfate are often found in extracellular matrix [1, 3], while heparan sulfate proteoglycans are found on most cells functioning as co-receptors for growth factors and in maintaining gradients of morphogen during development [21]. Patients with hereditary multiple exostosis (HME) display genetic effects in either EXT1, EXT2 or EXT3, causing partial loss of these enzymes involved in heparan sulfate synthesis. Aborted growth factor signaling, which normally negatively regulate chondrocyte proliferation and maturation, is thought to cause the characteristic boney outgrowths (exostoses) of HME [22].

Hyaluronan is the simplest of all GAGs lacking sulfations and with usually 104 repeating units of GlcNAc β 1-3GlcA β 1-4 (in contrast to the GlcNAc α 1-4GlcA β 1-4 in heparan sulfate) generating high molecular weight polymers. In contrast to all other GAGs, hyaluronan is not attached to proteins and its synthesis takes place at the cell surface [3].

Glycolipids

The first step in glycosphingolipid synthesis is the attachment of Glc (or Gal) to ceramide generating glucosyl (or galactosyl) ceramide, where glucosyl ceramide can be extended to lactosyl ceramide by addition of Gal (Gal β 1-4Glc-Cer). Further enzymatic steps generate glycolipids with shorter saccharide structures (e.g. sialylated lactosyl ceramide, GM3, Figure 1) or longer ones (e.g. GM1a), where the extensions may or may not be similar to those on N- and O-linked glycans. Glycolipids are divided into series depending on their core

structures (e.g. lacto-, globo-, isoglobo-, muco- and ganglio-series). The term ganglioside, however, is also used for glycolipids (of any series) with one or several sialic acid residues [3]. Glycolipids are suggested to be present in specialized membrane domains called 'membrane rafts' rich in cholesterol, structures which are central in receptor organization and signaling. Although an increasing number of studies support the existence of membrane rafts, it remains a controversial issue [23].

Few diseases have been identified that affects glycolipid synthesis, however, a loss-of-function of the sialyltransferase GM₃ synthase have recently been correlated to infantile-onset symptomatic epilepsy syndrome [24].

GPI-anchors

Glycophosphatidylinositol (GPI-) anchors consists of a phosphoethanolamine structure (to which the protein is coupled), and a stretch of four saccharides (3 mannoses and one GlcN), which in turn are linked to the membrane phospholipid phosphatidyl inositol (PI) (Figure 1). All share the same core, but variability exist. For example, further membrane interaction may be conferred by an added long-chain fatty acid. The GPI-precursor is assembled in the ER membrane before C-terminal cleavage of a protein translated nearby and transfer of this protein to the GPI-precursor. GPI-linked proteins are widely expressed in animal tissues but their physiological roles are still elusive [3]. As for glycolipids, they are suggested to reside in membrane rafts and affect signaling [23].

No inherited genetic defects in GPI-anchor biosynthesis are known but somatic mutations may occur in the gene *PIGA*, encoding a GlcNAc transferase initiating the GPI-pathway. In this disease (paroxysmal nocturnal haemoglobinuria, PNH), the offspring of abnormal multipotent haematopoietic stem cells lacking GPI-anchored proteins become resistant to apoptosis and dominate the population [13].

Deciphering the glyco code

The glycome can be defined as all glycan structures present in a cell, tissue or an organism, such as a mouse or a human. Glycomics can be defined as an approach to gain insight in the structure-function relationships of a glycome, often by the combined effort of several integrated processes. The speed of development of novel tools at the molecular, cellular, tissue and systemic level has increased as compared with a few years ago [25], and will continue to increase over the coming years. The construction and maintenance of large comprehensible bioinformatic resources is also important, which can be used in

the search for 'missing links' in glycobiology [26]. The Consortium for Functional Glycomics is one international collaborative initiative, among others also established in Europe and Japan. The main challenges for glycomics ahead are (i) explaining how glycan diversity is regulated and synthesized, (ii) understanding the basis of specificity in protein-glycan interaction, and (iii) elucidate how the plethora of glycans on a cell surface interact with proteins via multivalent interactions affecting signaling and cell-cell communication [27].

Protein-glycan interactions are tools with which the body 'deciphers' the intricate code held by glycan structures. The carbohydrate binding proteins involved are named lectins and are, by definition, structurally distinct from antibodies and do not exert enzymatic activity on the bound glycan. Based on their structural characteristics they can be divided into groups, main classes are P-type (e.g. Man-6-P-binding lectins), I-type (e.g. members of the immunoglobulin superfamily as siglecs), C-type (requiring Ca^{2+} , e.g. selectins) and galectins (formerly S-type lectins) [28].

Galectins – a little here, a little there

What is a galectin?

In 1853 Charcot and Robin observed crystals in tissues of a patient with leukemia, and similar ones were reported in sputum of asthmatics by Leyden in 1873. Despite these early findings, it was not until more than a century later (1993) the main constituent of these crystals was characterized as a lectin, and in fact, as a galectin (galectin-10) [29]. The first galectin, however, was purified from the electric organ of the electric eel (*Electrophorus electricus*) in 1975 [30], and required free thiols (reducing conditions) for activity. Hence, this family was first called S-type lectins [31], although most other members assigned to this family did not require reducing conditions for activity. In 1994 the definition of galectins was published to introduce a generally accepted (and unifying) nomenclature, and states “Membership in the galectin family requires fulfillment of two criteria: affinity for β -galactosides and significant sequence similarity in the carbohydrate binding-site, the relevant amino acid residues of which have been determined by X-ray crystallography (Lobsanov et al. 1993).” [32, 33]. Galectins are an ancient family found in phyla ranging from sponges to vertebrates [34, 35], and about 15 mammalian galectins have been reported so far.

Galectin structure

All galectins contain a carbohydrate recognition domain (CRD) through which they interact with glycans. They are either of mono-CRD type: galectins-1, -2, -3, -5, and -7; or bi-CRD type: galectins-4, -6, -8, -9, and -12 (Figure 2A). Mono-CRD galectins (except galectin-3) are often referred to as prototype galectins and bi-CRD galectins are called tandem repeat type. Despite the name tandem repeat galectin, the two domains of bi-CRD galectins are as different as two separate mono-CRD galectins. Galectin-3 is the sole chimera type galectin and has an extended N-terminal domain rich in glycine and proline [36].

The around 135 amino acids (aa) of the CRD form two slightly bent β -sheets on top of each other (β -sandwich), with 5 and 6 strands respectively (Figure 2B).

A groove on the concave side holds the glycan of maximum four monosaccharides length, each in a separate “sub-site” termed A-D (explained in detail below). β -galactoside specificity is conferred by seven highly conserved aa (in sites C and D) interacting directly with the glycan (Figure 2C), substitution of one or several of these ‘galectin signature’ aa are thought to explain the lack or very low β -galactoside binding by galectin-like proteins (galectin-10 (Charcot-Leyden crystal protein, CLC), GRIFIN, PP13 (galectin-13), PP13L (PP13 like protein), OVGAL11 (galectin-15), and HSPC159) [36]. These proteins could have affinity for other glycans, e.g. galectin-10 has been shown to interact with mannose [37]. Aa surrounding the ‘galectin signature’ differ between the various members and account for their individual fine specificities for both shorter and longer saccharides [38].

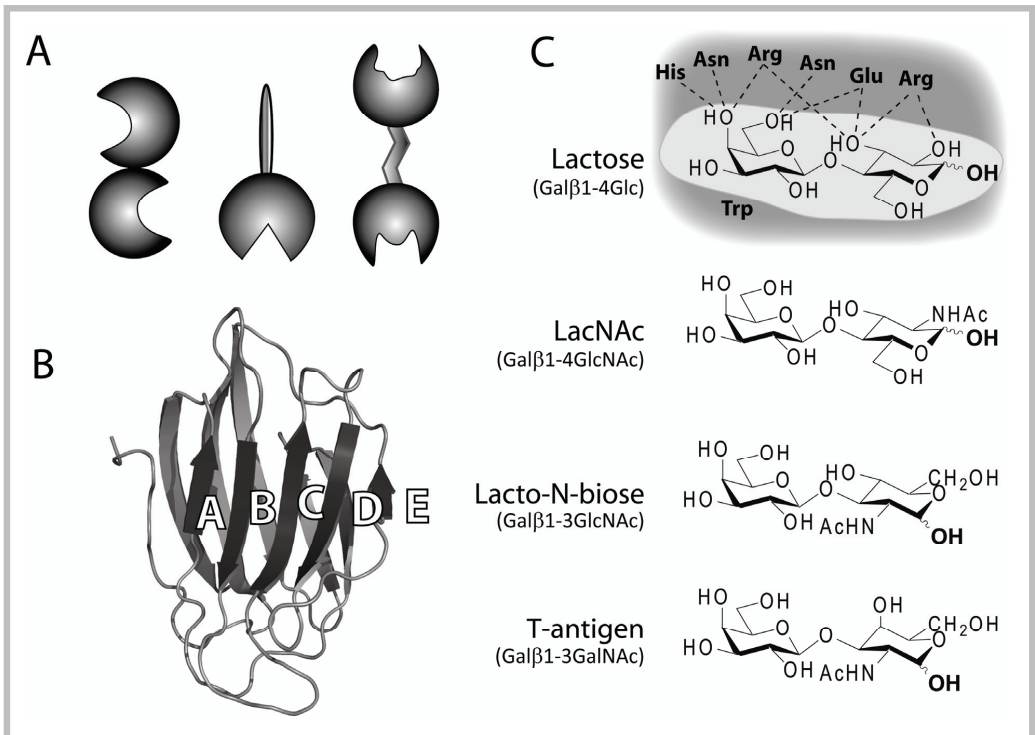

Figure 2 Galectin structure and β -galactosides. **A)** Schematic representation of mono- and bi-CRD galectins. Galectin-1 is shown as a non-covalent homodimer, and galectin-3, with its additional non-CRD domain, and galectin-8, with two distinct CRDs connected through a flexible linker, as monomers. **B)** Molecular model of a galectin CRD. The two β -sheets (light and dark gray) on top of each other form a groove where the glycan is bound. Core sites C and D interact with the β -galactoside itself while sites A and B interact with extensions at the non-reducing end (to the left of the disaccharides depicted in C). Site E is the area to the right of site D, and interacts with whatever the glycan is connected to (lipid, protein or other saccharides). **C)** Close up of bound lactose. The interactions between the galectin signature aa and the saccharide are shown by dashed lines, except for tryptophane which is stacked against the galactose ring. Variant β -galactosides are shown below.

Post-translational modifications, subcellular distribution, and non-classical secretion

Galectins are produced on ribosomes free in the cytoplasm and have an acetylated N-terminus, features typical of cytosolic proteins. Galectin-3 can be phosphorylated but no other post-translational modifications have been reported. None of the galectins have transmembrane domains, and they are found as soluble proteins in the cytosol, nucleus or extracellular space, or attached to surfaces (like the plasma membrane) via interaction with glycans. However, galectin-9 is the sole galectin proposed to adopt a strikingly different arrangement of its CRDs, traversing the membrane 4 times, and, in this conformation, function as a lactose regulated urate channel [39, 40].

To reach the extracellular space, galectins are secreted through a non-classical (non-ER-Golgi) pathway due to lack of signal sequence [36]. Several different mechanisms for unconventional secretion exist. Budding of membrane could be either direct of the plasma membrane (exovesicles) or indirect in the limiting membrane of a multivesicular body (creating a vesicle inside the vesicle). Similarly, protein translocation over a membrane can be direct over the plasma membrane (into the extracellular space) or indirect into an endosomal vesicle carrying the protein to the exterior [41]. Budding have been suggested for both galectin-1 and -3 [42] but recent reports indicate glycan-dependent direct translocation of galectin-1 over a membrane [41, 43]. In addition, galectin-3 has been shown to accumulate in LPH (lactase-phlorizin hydrolase)-containing outbound vesicles, sorting these vesicle to the apical surface of the cell [44]. This could be the first example of unconventional secretion of galectins via direct translocation into an endosomal vesicle. The exact mechanisms remain to be elucidated, and are likely to vary depending on cell type, galectin(s) and ligands present in the cell.

Multivalency and oligomerization

Many lectins have been found to use multivalent interactions to increase affinity for the generally weak carbohydrate-protein interactions between lectins and their ligands [45, 46]. Galectins are no exceptions and are thought to exert their functions by ligand crosslinking. Several mono-CRD galectins have been shown to dimerize [33, 47] or even form higher multimers upon ligand encounter [48]. Galectin-1 addition induces segregation of CD43/CD7 and CD45/CD3 glycoprotein receptors on the surface of MOLT-4 cells, receptors involved in the T-cell death induced by galectin-1 [49]. Likewise, galectin-3 crosslinks cell surface receptors and form a robust lattice on neutrophils, visualized by fluorescent resonance energy transfer (FRET); lattice formation was dependent on the non-lectin domain (N-terminal part) of galectin-3 and

was suggested to mediate the effects of galectin-3 on neutrophil function [50]. Similarly, galectin-3 lattice formation on the surface of T-cells is suggested to regulate T-cell receptor responsiveness and endocytosis of cytokine receptors [51, 52].

Bi-CRD galectins are naturally bivalent and have until recently not been reported to oligomerize. However, in the beginning of 2007, Miyanishi et al. showed that galectin-9 interacted with itself, galectin-3 and -8, but not galectin-1. The effect was dependent on the CRD since presence of lactose interrupted the interaction. However, it was rather a protein-protein interaction than a protein-carbohydrate interaction since the galectins used were produced in bacteria and devoid of glycan post-translational modifications [53].

Galectin function

Galectins have been implicated in a wide variety of functions under normal as well as pathophysiological conditions. Since galectins can be found in most cellular compartments and outside cells, effects are mediated both extracellularly and intracellularly [54] (Table 1). General cellular functions include cell adhesion (to another cell or to the matrix) [55, 56], host-pathogen interaction [57], induction of cell signaling [58], cell growth [59], and induction or inhibition of apoptosis [60-62]. The above mentioned effects make galectins efficient regulators of the immune system [61, 62] and modulators of tumor progression [63].

For recent reviews on the biology and multiple functions of the most extensively studied members, galectin-1 and -3, see [64] and [65].

Despite the many seemingly important functions of galectins, no overall biological role has yet emerged. Further, knock-out mice lacking galectin-1 and -3 are both healthy and fertile under animal house conditions (including the double knock out), although subtle defects are revealed when studied more in detail [66]. However, an emerging number of recent reports illustrate their contribution in pathological conditions, making them useful targets in medical interventions. For example, endothelial-expressed galectin-1 was found to be essential for tumor angiogenesis and is a target for tumor angiogenesis therapy [67]. Increased levels of galectin-3 in lung fibrosis patients were suggested to regulate fibrogenesis by activation of fibroblasts [68], an effect simultaneously shown to mediate liver fibrosis [69]. In addition, galectin-1 seems required for normal adult stem cell proliferation, a function which might be utilized for innovative therapies for human disease [70].

Galectin functions are highly dependent on the glycans displayed by a cell combined with the specificity for such glycans by the galectin. Hence, one way to gain better understanding of the galectins is to study their fine specificities and try to link them with their induced functions.

Table 1 Expression and functions of mammalian galectins and galectin-like proteins.

Galectin	Tissue expression	Proposed Function
1	Ubiquitous	Cell growth, cell migration, cell differentiation, cell death, nerve development, RNA splicing [64, 67, 70]
2	Gastrointestinal tract	Leukotriene α secretion, T-cell apoptosis [71, 72]
3	Ubiquitous	Cell growth, cell differentiation, cell adhesion, inflammation, RNA splicing, fibrosis, vesicular sorting [44, 65, 68]
4	Gastrointestinal tract	Membrane stability, raft organization, vesicular sorting, T-cell activation [73-76]
5 (rat)	Fairly ubiquitous	? [77]
6 (mouse)	Gastrointestinal tract, kidney, spleen, liver, heart	? [78]
7	Stratified and pseudostratified epithelia	Cell death, corneal wound healing, tumor progression [79]
8	Ubiquitous	Cell adhesion, cell growth, neutrophil modulator, tumor antigen [56, 80]
9	Leukocytes, liver, small intestine, thymus, lung, spleen, kidney, cardiac and skeletal muscle	Eosinophil activation, cell differentiation, cell death, cell adhesion, urate transport [39, 40, 81]
10 (CLC)	Eosinophils	? [82]
GRIFN	Lens	? [83]
12	Adipocytes	Cell death, growth regulation [84-86]
PP13	Placenta, fetal liver, spleen	Immunobiology functions [87]
14 (sheep)	Eosinophils	Allergic inflammation [88]
Ovgal11 (sheep)	Uterus	? [89]

Galectin-8

Discovery of galectin-8

In 1995, galectin-8 was first isolated from a rat liver cDNA library screened with an antibody against insulin receptor substrate-1 (IRS-1) [90]. The fortuitous interaction was probably caused by unspecific recognition of glycosylations on the antibody, since the found protein had no homology whatsoever to IRS-1. Shortly thereafter, a human homologue was identified as a prostate carcinoma tumor antigen, and named PCTA-1 [91, 92], almost in parallel with identification of a lung cancer antigen detected by the monoclonal antibody (mAb) Po66 [93]. Both these proteins showed homology to the rat galectin-8 and to each other. The lung cancer antigen was initially termed Po66-carbohydrate binding protein (CBP), which later was changed to galectin-8.

These initial studies characterized a protein with two CRDs joined through a linker peptide, lacking both signal sequence and transmembrane domain. The CRDs showed 38% aa identity to each other and ~40% identity to other galectins. In addition, this ubiquitously expressed protein (both in rat and human tissues) was present in several isoforms originating from splice variants of the gene [90, 91, 93].

Galectin-8 isoforms

Galectin-8 and galectin-9 are bi-CRD galectins found in several isoforms due to alternative splicing (and for galectin-9 multiple genes), resulting in proteins with linkers differing in linker length or linker aa content [94-96]. In a lung carcinoma cell line, several mRNAs were detected which corresponded to five theoretical proteins isoforms, whereof two were full length galectin-8 proteins (with both N- and C-CRD and a linker of either ~30 aa or ~30 + ~43 aa) and three were truncated (containing only the N-terminal CRD and a part of the linker) [94]. Human prostate cancer cell lines also showed multiple mRNAs, however, no transcripts coded for truncated proteins [91]. No correlation between individual isoform transcripts and cell stage could be made as most tissues (normal and tumoral) express them to various degrees [91, 93, 94], although in many tissues the shortest variant (the one with around 30 aa linker) seemed more abundant [91]. Accessory number O00214 in the NCBI protein databank lists 3 protein isoforms where one is of short type (~30 aa linker) and two have the longer linker of around 70 aa. The aa sequence in the insertional 40 aa part differ between the two longer proteins. Until today, presence of isoforms in tissues has mostly been shown by mRNA studies. A few reports using Western Blots, where two separate protein bands are visible, have been published [97, 98]. No immunohistochemistry or flow cytometry has been performed since isoform-specific galectin-8 antibodies are not available.

The function of the multiple isoforms of galectin-8 and -9 remain unknown. The galectin-9 linkers (short, medium or long) are sensitive to proteases such as thrombin [99], elastase, or matrix metalloproteinase-3 (MMP-3), but barely trypsin [100]. Galectin-8 with short linker was efficiently cleaved by trypsin and elastase, but not with MMP-3 [100]. In addition, a long linker galectin-8 was also an efficient substrate for thrombin [99]. Generation of linker-deficient proteins rendered them resistant to protease cleavage, while their potency to mediate biological functions such as eosinophil chemoattraction (Gal-9), apoptosis of T-cells (Gal-9), and neutrophil adhesion (Gal-8) were unaffected or even increased [100]. Sensitivity to protease cleavage may be a regulatory mechanism on the effects mediated by galectins-8 and -9 as several biological activities requires both CRDs [101, 102](Fig. 5, Paper I).

Galectin-8 expression in normal tissues and cancer

Various approaches have been used to compare the galectin-8 expression in different normal, embryonic and tumor tissues, both at the RNA level [91-94] and protein level [93, 103-107]. Galectin-8 is probably the most ubiquitously expressed galectin in the body as well as in human cancers, although the expression in embryonic tissues is low [108]. In a panel of 61 tumor cell lines, 59 were positive for galectin-8 [109], which was the highest score among the 7 human galectins tested (galectin-1, -2, -3, -4, -7, -8, -9). A similar approach conducted by us in collaboration with Michael McGuckin at Mater Medical Research Institute, Brisbane, Australia, on a panel of tumor cells isolated directly from the primary tumor of patients with ovarian carcinoma (25 samples) or cells enriched from peritoneal fluid (26 samples) showed similar results (Table 2, unpublished data). However, in this study several galectins including galectin-1, -3, and -9 were also ubiquitous, exemplifying the fact that one cell often expresses several different galectins. The somewhat conflicting results from various methods in determining the presence of galectin-8 in tissues, together with lack of trend (increase or decrease of galectin-8 expression) during tumorigenesis, shows the difficulty in determining a precise role of galectin-8 in cancer [108, 110].

The intracellular localization of galectin-8 is in the cytosol of cells [91-93], but galectin-8 is also readily seen at the plasma membrane [80, 91, 92] as a result of unconventional secretion by the cells [92, 98]. Occasionally galectin-8 is also seen in the nucleus [94].

Discovery of galectin-8 in humans as two separate tumor antigens provided a possibility for clinical use of galectin-8 in individual cases. Po66 was developed in an attempt to obtain lung squamous cell carcinoma reactive antibodies, which could be radiolabeled and used in tumor imaging and treatment. In this respect Po66 development was a success, and positive trial experiments were performed on both mice and man [111-117]. However, the absence of publications

during recent years makes it unlikely that this antibody reached clinical use yet. Although galectin-8 (or PCTA-1) was thought to be specifically expressed on prostate tumors, both mRNA and protein have been detected in normal prostate too [108], and this antigen is not used as a tumor marker. The location of the galectin-8 gene on chromosome 1q42-43 predisposed galectin-8 as a possible candidate gene for early-onset prostate cancer [118], but detailed analysis performed a few years later showed that this was not the case [119].

Table 2 Expression of galectin mRNA in ovarian carcinoma^a.

	No signal	Band intensity (%of 51 samples)			
		+	++	+++	++++
Galectin-1	4	25	37	16	18
Galectin-2	25	25	8	4	37
Galectin-3	0	6	12	10	73
Galectin-4	35	43	16	4	2
Galectin-7	27	22	12	4	35
Galectin-8 L	4	24	29	16	27
Galectin-8 S	2	25	20	16	37
Galectin-9 L	2	4	22	29	43
Galectin-9 S	0	2	4	8	86
Galectin-12	33	33	10	6	18

a) Galectin RT-PCR on mRNA extracted from ovarian carcinoma tumor cells (primary tumor or cells in the peritoneal fluid). The intensity of bands was measured densitometrically and classified as: 0 No signal; + Weak intensity; ++ Moderate intensity; +++ Strong intensity; ++++ Very strong intensity. The table lists % of samples in each class, total number of samples is 51.

Galectin-8 in adhesion of cells

Galectin-8 is a matricellular protein with both inhibitory and stimulatory effects on cell adhesion. In the presence of serum, soluble galectin-8 added to H1299 and other cell lines inhibited their adhesion to non-coated plates. In addition, galectin-8 coated on a surface also inhibited attachment of cells in the presence of serum. These effects were shown to be mediated by a CRD-dependent interaction with integrins α_3/β_1 and α_6/β_1 , but not α_4/β_3 [98]. In contrast, when cells were let to adhere to a galectin-8 coated surface in the absence of serum, galectin-8 promoted cell adhesion and cell migration, in part mediated by integrin α_3/β_1 . Co-coating the plates with serum decreased adhesion, and although fibronectin is a galectin-8 serum ligand, it had rather a promoting than inhibitory effect on cell adhesion when co-coated on plates [101]. Further studies showed that after adhesion to galectin-8, cells had less stress fibers and focal adhesion contacts as compared with cells adhered on

fibronectin, in addition, they had also increased number of cell sprouting (lamellipodia) and microspike formation (short individual projections of F-actin). The cellular signaling induced upon binding to integrins and adhesion on galectin-8 involved sustained activation of several intracellular pathways, all initiated by autophosphorylation of focal adhesion kinase (FAK); (i) increased phosphorylation of p130^{Cas} (ii) recruitment of PI3K and activation of Ras which leads to phosphorylation of ERK 1/2, and (iii) recruitment of PI3K, activation of PKB and increased phosphorylation of p70 S6 kinase (p70S6 K). Inhibition of the central PI3K significantly inhibited the typical microspike formation [101, 120].

Coating of galectin-8 to plates was also recently shown to promote adhesion and spreading of the activated Jurkat T-cells and peripheral blood mononuclear cells [121]. Surface coated galectin-8 engaged mainly Jurkat $\alpha 5\beta 1$ integrins, but also $\alpha 1\beta 1$ and $\alpha 3\beta 1$ (but not $\alpha 2\beta 1$ or $\alpha 4\beta 1$), and lead to activation of the PI3K/MAPK pathway (with phosphorylation of ERK1/2) in parallel to activation of Rac1. These signals lead to cytoskeletal rearrangements and cell spreading, and Jurkat cells display a polarized phenotype with many lamellipodia protrusions and occasional filopodia when adhered on galectin-8. Further, Carcamo et al. showed that autoantibodies found in patients with systemic lupus erythematosus (SLE) functionally blocked galectin-8 mediated adhesion, the first discovery of galectin function-blocking antibodies with possible implications in both normal and pathological immune reactions [121].

Galectin-8 in cell growth and apoptosis

Galectin-8 can affect both cell growth and cell death (apoptosis) in cells [98, 122]. Cells transfected to overexpress galectin-8 (intracellularly) soon die, if they do not have a growth advantage by also overexpression of insulin receptor, which may override the growth-inhibitory effects [122]. In addition, extracellularly added galectin-8 in high concentration also induces growth arrest in several cell lines (4 out of 5 tested). This effect is mediated by an increase of the cyclin-dependent kinase inhibitor p21 (waf1) through activation of both the PI3K/PKB pathway, as well as SEK/JNK pathway [122].

Presence of serum is decisive whether or not galectin-8 induces apoptosis [98, 122]. Soluble galectin-8 added to lung cancer cells in a serum free milieu induces apoptosis; but this effect is not seen in presence of serum [98].

Galectin-8 modulates neutrophil migration and function

Neutrophils are important effector cells whose extravasation from blood into injured tissues is crucial in innate immunity. Adhesion of neutrophils could be induced by addition of soluble galectin-8, interacting in part via its C-CRD binding to integrin α M [80]. Further, galectin-8, and in particular the N-terminal CRD of galectin-8, interacts with a precursor of an enzyme used to degrade extracellular matrix called pro-matrix metalloproteinase-9 (proMMP-9). For this enzyme to be in its active form it needs to be cleaved by another enzyme, MMP-3. Galectin-8 was shown to affect this process by recruiting MMP-3 and act as a catalysator in its processing of pro-MMP-9 to MMP-9 [80]. Taken together, both these effects can thus modulate the extravasation of neutrophils *in vivo*.

Following extravasation, neutrophils eat (phagocytose) and kill bacteria and other infectious agents in part by producing reactive oxygen species (oxidative burst), a process elicited by intact galectin-8, showed both by Nishi et al. [80] and us (Fig.5, paper I). In contrast to Nishi et al., who could detect O_2^- production with both intact galectin-8 and a mutant galectin-8 with only a functional C-CRD, we did not see any stimulation of oxidative burst by either domain separately, but only with two intact variants (with either a ~30 aa linker or ~70 aa one) (Fig. 5, paper I). The discrepancy in our results may come from different techniques used in measuring the oxygen radical production and/or different approaches in construction of the mutant variants of one functional CRD galectins (point mutation vs. truncation).

Objectives

The aim of this thesis has been to increase the understanding for one of the most wide spread, but still largely unknown, galectin members – galectin-8. By investigation of the carbohydrate preference of each CRD, and detailed studies on how this preference was built, we wanted to provide a basis for how galectin fine specificity is achieved. As a next step, we wanted to relate this fine specificity to physiological events, like cell surface binding and induction of cellular signaling, to gain insight into how galectin glycan preference provides the means for functional selectivity, despite the presence of a glycan plethora on a cell surface.

Galectin-carbohydrate interactions

Specificity – a key to biological function

A galectin's biological function is based on its interactions with ligands, and hence, affinity measurement is one of the keys to its understanding. Several methods have been used to determine galectin fine specificities over the years. Isothermal titration microcalorimetry (ITC) has been employed for some of the galectin members (galectins-1, -3 and -7, reviewed in [123]), and is considered an ideal binding assay since no chemical modification of either binding partner is needed. However, it requires high amounts of both ligand and protein, concentrations at which many galectins tend to aggregate and precipitate. The method is also unpractical for screening of large number of compounds. Most other methods involve attachment of either the galectin to a surface, or a reporter (such as a fluorescent tag) to the ligand, which both have a possibility of affecting the functionality of the interaction. A selection of methods to measure affinity will be described below and their relation to galectin-8 specificity analysis by us and others.

Frontal affinity chromatography

The most comprehensive study on galectin specificity was made by Hirabayashi et al. using a method called frontal affinity chromatography (FAC), with which they investigated the affinity of 13 different galectins or galectin-CRDs against 41 pyridylaminated (PA-) oligosaccharides [38]. The 'reinforced FAC' used was a further improvement of the method developed by Kasai and Ishii in 1975, and was faster, simpler, and more sensitive as compared to the original [124]. It is suitable for analysis of several different types of interactions, including protein-saccharide ones. In principle, the method measures how much a fluorescently labeled saccharide is retarded when flowed at constant concentration over a column with immobilized galectin. By comparing the elution volume of the ligand (graphically determined by plotting fluorescence intensity against retention time) to the corresponding volume for a non-binding ligand, the affinity in terms of dissociation constant (K_d) can be calculated. The main drawback with this method is that both the galectin and the sugar are chemically modified. The effect of immobilizing the galectin to a surface is hard

to evaluate, but could possibly affect binding by steric hindrance and/or crosslinking, e.g. when the galectin binds larger saccharides. Pyridylamination, involves opening of the reducing end sugar [38], which has been shown to decrease binding to galectins [125]. This effect is only seen when the saccharide is short (2-4 units) and the reducing end sugar participates in binding to the galectin core binding site.

FAC affinity measurements confirmed the general property of galectins that no substitutions on Gal 4'OH or 6'OH, or Glc(NAc) 3(4)'OH, in Gal β 1-3(4)Glc(NAc) are tolerated. Galectin-8 was one of the galectins which bound well to glycolipid derived saccharides like GM₃ (NeuAc α 2-3Gal β 1-4Glc, 3'SA-Lac), **GD1a** (NeuAc α 2-3Gal β 1-3GalNAc β 1-4(NeuAc α 2-3)Gal β 1-4Glc), **LNF-III** (Gal β 1-4(Fuc α 1-2)GlcNAc β 1-3Gal β 1-4Glc), and **A-hexa** (GalNAc α 2-3(Fuc α 1-2)Gal β 1-3GlcNAc β 1-3Gal β 1-4Glc), and to polylectosamines like **LacNAc5** (LacNAc β 1-3)₅ (for K_d -values see Table 3). Both CRDs were included in the analysis as separate proteins and it was obvious that the N-CRD mediated affinity to 3'SA-Lac, GD1a, and LNF-III while the C-CRD preferred A-hexa. The strongest interactions for the N-CRD (to GD1a and 3'SA-Lac) were 0.5 and 0.62 μ M respectively, and 1.6 μ M (to A-hexa) by the C-CRD. Lactose did not bind particularly well to galectin-8, although a K_d of \sim 130 μ M was estimated for the N-CRD, but as mentioned above the affinity could have been decreased by opening of the Glc ring. For further details of galectin-8 binding affinities, and the affinities for the other galectins tested, please refer to Hirabayashi et al. in ref [38].

Although FAC analysis is a powerful tool in giving an overview of the specificity of a specific lectin towards a panel of glycans, the method lacks precise structural information of each interaction. Taken into account that most saccharides tested in the experiment described above contains 3-6 monosaccharides, and numerous of those have 2 potential β -galactoside binding sites where the disaccharide at the reducing end has an opened ring, it is hard to say which of the epitopes is really conferring binding. For example, is the strong binding of galectin-8 N-CRD to GD1a requiring the full length tetrasaccharide with two sialylations, or is the N-CRD just binding to the terminal disaccharide (Gal β 1-3GalNAc) having one sialylation? The above mentioned reason, in addition to the possible error in affinity value towards di- and trisaccharides, makes FAC insufficient for detailed mapping of galectin fine specificity. However, an automated screening based on this method capable of screening 100 lectins against 100 saccharides [126] will still be a great contribution to galectin profiling.

Table 3 Affinity constants (μM) for the galectin-8 N- and C-CRD^a.

	FAC		SPR		FP – direct		FP – inhibition
	N	C	N	C	N	C	N
Lac	130	-	79	440	1.7	50-150	90
3'SA-Lac	0.62	-	2.7	190	0.05	-	0.68
3'Su-Lac	ND	ND	1.9	>1000	ND	ND	ND
LNnT	7.6	52	13	57	0.33	16	12.2
LNF-III	1.6	100	3.3	84	0.24	20	ND
A hexa ¹ / tetra ²	- ¹	1.6 ¹	280 ²	12 ²	50-150 ²	8.9 ²	ND

a) FAC, frontal affinity chromatography [38]; SPR, surface plasmon resonance [127]; and FP (Table I, paper I) either direct or by inhibition. ND – not determined

Enzyme linked lectin assay and Surface plasmon resonance

Both enzyme-linked lectin assay (ELLA) and surface plasmon resonance (SPR, BIAcore) measurements involve attachment of one of the interacting partners to a surface. In ELLA (or ELISA) the carbohydrate is often coated at the bottom of wells, and added lectin which has bound to the carbohydrate, is detected with an enzyme (either conjugated to the lectin itself or to secondary antibodies). Read signal intensity (conversion of enzyme substrate) is plotted against lectin concentration and a nonlinear curve fitting of the data points permits estimation of relative affinity constants. ELLA has e.g. been used to determine the carbohydrate specificity for galectin-1 [128] and galectin-8, the latter in combination with SPR [127].

Almost every biomolecular interaction can be studied by SPR, including its kinetics. Therefore, not only equilibrium binding data but also rate constants for the association and dissociation can be determined. Biosensors convert changes in mass close to the surface into a signal, and the greater the mass change the stronger the signal. In the case of galectin-glycan interactions, either the galectin or the saccharide is coated on the surface, using the other one as soluble analyte. Inhibition experiments can also be performed in which a carrier molecule (e.g. asialofetuin) is coated to the surface to which the galectin is allowed to bind. The ligand of interest (the saccharide inhibitor) is thereafter flowed past the bound galectin and dissociates the galectin-asialofetuin complex. Inhibition experiments require no modification of any of the studied binding partners.

SPR was used by Ideo and co-workers to study the specificity and affinity of galectin-8 to a panel of 22 saccharides including disaccharides (e.g. lactose,

LacNAc and Gal β 1-3GalNAc (T-antigen)) and longer saccharides with up to six monomers [127]. The affinities were comparable with those previously determined by FAC (Table 3). Their results also showed a preference for both 3'SA-Lac (K_d of 2.7 μ M) and 3'sulfated Lac (SO $_3^-$ -3Lac, K_d of 1.9 μ M), a binding which was attributed to glutamine 47 (Gln47, Q47) in the N-terminal domain. Interestingly, glycolipids containing either an 3'SA or 3'sulfate bound even stronger to the N-CRD than the separate saccharides, with K_d s in the low nanomolar range (from 7.1 nM for SM3 (SO $_3^-$ -3Gal β 1-4Glc β 1-1Cer to 37 nM for snLc4Cer (Neu5Ac α 2-3Gal β 1-4GlcNAc β 1-3Gal β 1-4Glc β 1-1Cer). Adhesion of CHO cells and affinity experiments suggested that galectin-8 binds both sialylated glycolipids (GM3) and glycoproteins on their cell surface [127].

Fluorescence polarization

Fluorescence polarization assay (FP) measures affinity in solution for a range of molecular interactions and is a simple, fast, inexpensive and sensitive method. Its microtiter plate format makes it suitable for high-throughput screening, and it can be used for kinetics or equilibrium constants. The big advantage of FP is that it does not require separation of bound and non-bound phases [129].

FP is based on the observation from 1926 that fluorescently labeled molecules emit polarized light if they are excited with polarized light [129]. However, during the time from excitation to emission (around 4 ns for fluorescein), the probe in solution (a fluorescently labeled saccharide in our case) have time to rotate thus causing a depolarization. Degree of depolarization is dependent on the size; smaller molecules tumble a lot faster than larger ones, and, therefore, cause more depolarization. The drastic difference in depolarization when the probe is bound to a much larger molecule (the galectin), as compared to when it is free in solution, correlate directly with the ratio of free/bound probe. Polarization is measured as polarization (P) or anisotropy (A), the latter being simpler mathematically and the term used in this thesis [130]. A detailed description of the principles of FP is given by [131].

The curve obtained in direct binding by plotting anisotropy against galectin concentration, starts with unbound probe (A_o) and increases towards a maximum value corresponding to bound probe (A_{max}) (Figure 3). The position of the curve along the X-axis reflects the affinity, with K_d being approximately the concentration where half maximal binding is reached, and the shape indicate binding complexity (e.g. multiple binding sites). A_{max} reflects the tumbling of the complex as a whole and is dependent on the size, temperature and viscosity of the solution. However, movement of the fluorescein moiety independently of the rest of the complex, called segmental motions or propeller effects, decreases the A_{max} value. Hence, the A_{max} also reflects the local environment of the

fluorescein, and can be used to determine how a saccharide is bound to the galectin [130] (paper I).

FP can also be used for inhibition experiments, in which a formed complex between the galectin and a probe is dissociated by an inhibitory saccharide. The K_d for the inhibitor can be calculated from each data point, as described in [130].

We used FP to determine the specificity of galectin-8 and its separate CRDs, towards a panel of 23 naturally occurring glycans. For a complete list of determined affinities and A_{max} -values please refer to Table I in paper I. Our results were specificitywise in accordance with the two previously published reports, but the calculated affinities were about 10 times stronger (Table 3). By comparing the affinities towards glycans from direct binding to their equivalent glycan in inhibition experiments (using non-labeled saccharides) we concluded that the increase in affinity was due to interactions with the fluorescein-linker part (Table 3, paper I).

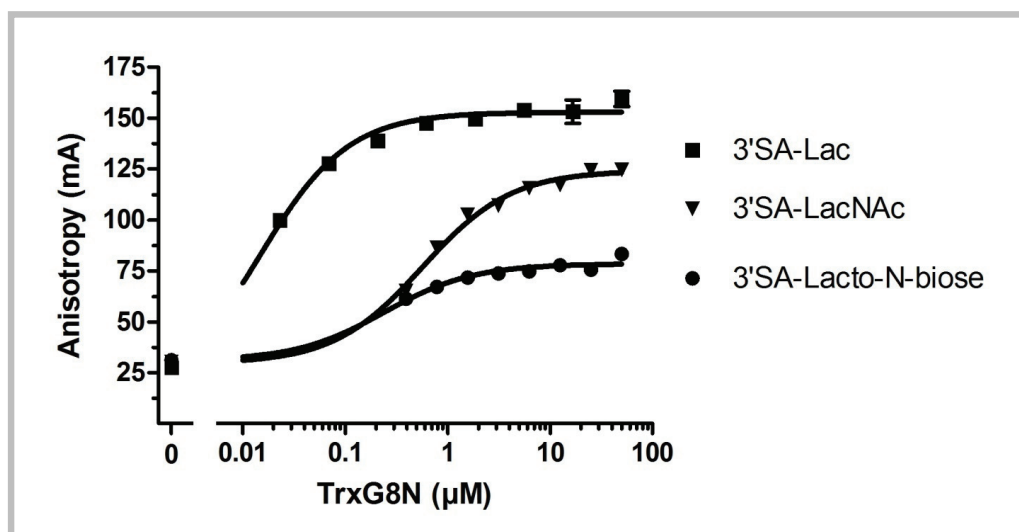

Figure 3 Fluorescence polarization curves. Binding of the galectin-8 N-CRD to the three sialylated probes 3'-Lac (■), 3'SA-LacNAc (▼), and 3'SA-Lacto-N-biose (●) are depicted by plotting the anisotropy against galectin concentration. All curves start at a value where no probe is bound, A_0 , and increases with galectin concentration to a value where all probe is bound, A_{max} . Propeller effects, or independent movements of the fluorescein moiety separate from the rest of the complex, decreases A_{max} , as seen for 3'SA-LacNAc and 3'SA-Lacto-N-biose. K_d is approximately equal to the concentration where half-maximal binding is reached.

Taken together, four methods (including glycan array discussed below) clearly show the difference in specificity between the two CRDs of galectin-8, with an outstandingly strong monovalent affinity for 3'SA- and 3'sulfated lactose of the N-CRD (Table I, paper I) [38, 127], uncommon for protein-carbohydrate interactions [132]. Most saccharides tested had an affinity of 1-10 μ M for the N-CRD and 10-100 μ M for the C-CRD. Based on the results from FP we have taken analysis of binding one step further and explained how the sub-micromolar affinities can be achieved.

Glycan array

Microarray techniques enable analysis of a large complement of genes or proteins in parallel, and have since 2002 included glycans [133, 134]. They hold the promise to revolutionize several fields, e.g. cancer by identifying tumor subclasses and specific genes for diagnosis and treatment [134], and glycobiology by profiling lectin binding specificities and presence of glycan-recognizing antibodies in serum [133], to mention a few. Although the ideal glycan microarray would contain the glycome of a whole organism, difficulties in production of certain glycosidic linkages limit the number of glycans available. Several glycan array formats exist where the mode of attachment of the glycan (covalent or non-covalent) to the solid support is the main difference [133]. The Consortium for Functional Glycomics (www.functionalglycomics.org) have glycan arrays where amino-linker coupled carbohydrates are printed and covalently bound (via amide bonds) to glass microscope slides. The current version holds 285 glycan targets, each present in 6 independent spots. A fluorescently labeled lectin is incubated with the chip and is after washing analyzed in a scanner for fluorescence intensities [135]. Secondary labeling via antibodies can also be used. Representative members of various lectin families have been successfully analyzed including C-type lectins, siglecs, galectins, anti-glycan antibodies and viral and bacterial lectins [78, 135] (paper I). There are also promising initial attempts where bacterial and even eukaryotic cells have been bound to arrays [133].

Glycan arrays are excellent in the initial screening determining glycan specificity for a certain lectin. In combination with other methods, like FP which can provide the details of a specific interaction (affinity and mode of binding), comprehensive mapping of fine specificities can be accomplished.

Other assays

Previously, other assays were commonly used to determine galectin specificity and affinity. Thin layer chromatography overlay assay were used to study specificity of galectin towards glycolipids and neoglycolipids (glycans not normally found on glycolipids which have been chemically linked to a lipid). The lipids were immobilized on silica chromatograms and later incubated with lectin and detected with radiolabeled antibodies [136].

The earliest assays (1970's and 1980's) were usually based on inhibition of lectin binding to particles, detected as hemagglutination of e.g. rabbit red blood cells or binding of radiolabeled lectin to asialofetuin-sepharose. The inhibitory potency of a panel of soluble saccharides provided relative affinities [137-139].

Galectin fine specificity is built by weak interactions to multiple subsites

A galectin CRD can be seen as having five different subsites, A-E, where sites C and D holds the core β -galactoside (Figure 2B and C). Most of the 'galectin signature' aa are found in site C where multiple hydrogen bonds and a van der Waal interaction tightly interacts with the galactose residue. Remaining 'galectin signature' aa interacts with the Glc(NAc) in site D, although not as tightly as for Gal [33, 140]. The transition from free to bound state for the molecule A, when it interacts with a protein, costs energy. This energy cost is mainly due to the loss of entropy upon forming a complex, as two particles become one [141, 142]. For an interaction to be detected by affinity measurements, the energy needs to be large enough to both 'pay the cost' of this entropy loss and contribute to the interaction itself. This can be described in terms of Gibbs free energy by the formula $\Delta GA_{total} = \Delta GA_{int} + \Delta GA_{rigid}$, where the energy promoting the interaction is ΔGA_{int} and the cost is ΔGA_{rigid} . However, when the molecule (A) is elongated by a fragment, B (exemplified by Glc added to Gal in lactose), the 'cost' has already been paid for by the first interaction (with A), and B only contributes with energy that enhances the interaction itself (ΔGB_{int}) [141, 142]. Therefore, fragments with very weak, not even measurable, affinities by themselves, can have very significant effects on affinity when added to another already bound moiety.

Such an analysis correlates well with the properties of galectins for which only one monosaccharide has a measurable affinity, namely galactose in site C bound via the multiple interactions described above (K_d is ~5 mM for galectin-8 N-CRD), apparently enough to 'pay' the entropy loss. Additional monosaccharides, interacting with fewer aa in sites D, B and A do not have to pay entropy loss again, and will therefore enhance binding about 10-100 fold each, increasing affinity to e.g. 50 nM as seen for 3'SA-Lac by galectin-8 N-CRD (Table II, Paper I). Interactions outside the proper binding groove may also

contribute substantially to affinity by analogous arguments, exemplified by the 10 fold increase in affinity for probes used in FP. Here, the fluorescein-linker part is thought to interact with a loosely defined area outside the proper binding groove called site E (Figure 2B). It's not unlikely that the continued oligosaccharide chain, lipid part of a glycolipid [127], or the protein part of a glycoprotein [143, 144], can affect affinity of galectins, also *in vivo*. Since several proteins and lipids produced by a cell can bear similar glycan structures, a modulation of affinity by the protein or lipid part might provide the selective means needed for engagement of specific receptors only.

FP A_{\max} -values and molecular modeling of the galectin-8 N-CRD helped us to further understand the wide range of affinities displayed by this domain. As explained above, the A_{\max} -value reflects the local environment of the fluorescein (exemplified by the curves in Figure 3). Therefore, saccharides which had an A_{\max} -value similar to short glycans with only one binding site (e.g. lactose and 3'SA-Lac) were suggested to bind the disaccharide closest to the fluorescein-linker (marked bold in Table I, paper I) in sites C-D. This enabled us to determine which of the two possible β -galactosides present in longer glycans (e.g. LNnT (Gal β 1-4GlcNAc β 1-3Gal β 1-4Glc) and LNF-III) bound in site C-D. If the outer β -galactoside would have been bound (as for GM1, Table I paper I), the A_{\max} -value would decrease due to elongation of the linker by the extra lactose residue and increased mobility of the fluorescein moiety. The model built of galectin-8 N-CRD in complex with LNnT, did not only show that the LNnT tetrasaccharide indeed could fit in the galectin-8 CRD, but also that tyrosine 141, situated in site A, could be important for binding. Aborting this presumptive stacking interaction by mutation of the tyrosine to a serine, significantly decreased affinity (Table III, paper I). A similar model with liganded 3'SA-Lac suggested that an interaction is formed between the sialic acid carboxylic acid and the two B-site aa R45 and Q47. This could explain the decreased affinities seen for the Q47A-mutants made by Ideo et al. [127] and us (Table III, paper I).

Galectin-8 binding ligands on a surface

The almost 300 glycans present on the glycan array both confirmed and broadened the specificity profile for the two CRDs of galectin-8 (Fig. 2, paper I). The glycans that bound the N-CRD the best all contained α 2-3-sialylation or 3'sulfation. In addition to the sialic acid Neu5Ac, both Neu5Gc and KDN were equally well tolerated, as well as Neu5Ac α 2-8 elongations. This tolerability was explained by modeling where the 5-position of the sialic acid clearly was directed outwards from the galectin into the solution. Array data also showed a promiscuous behavior towards the precise type of the core β -galactoside (Lac = Gal β 1-3GlcNAc = Gal β 1-3GalNAc > LacNAc) (Figure 2C), and if the Glc(NAc) or GalNAc in site D was 6'sulfated or not. The weaker affinity of the C-CRD to most saccharides shown by affinity measurements (FAC, SPR and FP) could

explain the fewer glycans bound on the glycan array. Low signal intensity is in addition due to lower specific fluorescent labeling, but could also be an effect of washing as discussed below. The best ligands contained the A-determinant (GalNAc α 1-3(Fuc α 1-2)Gal-), and a few others the B-determinant (Gal α 1-3(Fuc α 1-2)Gal-) (Fig. 2, paper I).

A routine approach in glycan array analysis is to create multivalency for lectins to withstand subsequent wash steps [135], a characteristic supposedly not fulfilled by our separate domains and a possible explanation to the lower binding observed with domains only. The recently suggested effect of protein-protein interaction of galectin-9 with itself and other galectins was shown to mainly be mediated by its N-CRD [53]. If this would be the case also for galectin-8, it could explain the stronger binding of the N-CRD over the C-CRD to the array. Cell surface binding experiments with domains analyzed by flow cytometry, however, do not support that washing should decrease the signal on the array (unpublished data).

Specificity of intact galectin-8 in solution vs. at a surface

The two CRDs in intact galectin-8 appear to act independently of each other in solution, as the specificity of the intact galectin-8 in FP was the sum of that for each CRD (Table I, paper I). Moreover, the potency of lactose to inhibit binding of an N- or C-CRD specific probe was the same as with each CRD separately (not shown). On the array, however, the two domains acted synergistically, and several glycans not binding either domain by itself bound intact galectin-8 (short or long isoform) strongly (Fig. 2, paper I). Such glycans had at least two repeated β -galactosides and 'sub-unit' multivalency with the bivalent galectin could explain such an effect [140]. The dramatic effect of multivalency seen for intact galectin-8 on the array could also be expected to be seen for the bi-CRD mouse galectin-4 in a similar analysis [78], which, however, was not the case. The concentrations used for galectin-4 in this assay were rather low (0.07 μ M to 1 μ M), and if they were increased to the level used with galectin-8 (0.7-1.2 μ M for test at low concentration and 3.5-6 μ M for high) both multivalent synergistic effects and a broader range of specificity for the two CRDs could be expected.

Fine specificity in cell surface binding

Multivalency may enhance affinity of lectins

Multivalency is frequently seen in nature to enhance binding strength for the often weak ligand-glycan interactions with K_{d} s between 1-1000 μM [38, 132, 140]. A linear increase in ligand valency can generate exponential increase of affinity to its receptor [132, 145]. The C-type lectin, hepatic asialoglycoprotein receptor with function to endocytose desialylated glycoproteins from the blood (having exposed Gal/GalNAc), is an excellent example of such a correlation. The smallest functional unit of this lectin consists of three monomers bundled together in a trimer with a precise intramolecular spacing of the binding sites to perfectly fit the three branches common to N-linked glycans. If ligand valency of a synthetic inhibitor (with spacing that matches the lectin subunits) increases from one terminal galactose, to two, to three the affinity can increase from millimolar, to micromolar to nanomolar [145, 146]. The addition of a fourth galactose, however, had little effect [146]. From this experiment and others it is clear that spacing is of utmost importance in multivalent interactions [145-149]. In a perfect fit, the affinity of each partaking interaction is multiplied with each other (as for asialoglycoprotein receptor where millimolar \times millimolar \times millimolar equals nanomolar) [145]. However, in a non-perfect fit, a conformation can be reached through adjustments of the subunits (ligand or lectin) so the interaction can take place anyway. Since such movements cost energy, the resulting affinity (and glycosidic cluster effect) is not maximal [145]. Sterically fit dendrimers have high enough affinity to *E. coli* produced shiga toxin to be able to rescue mice from its lethal effects [148, 149], and pose as new potent therapeutics.

Galectin-8 affinity to a cell surface

Synergistic effects are seen when one of the interaction partners is displayed in a multivalent fashion on a surface, e.g. the repeating units of glycan on the array, or glycoconjugates on a cell surface. Indeed, the synergistic effect of intact galectin-8 (both long and short linker) was not only seen to the array but also upon binding to cells. Strong binding was found at low concentration (0.2 μM) (Fig. 3A, paper I), but no binding of the separate CRDs. Further, increasing the

amount of added galectin-8, the binding to cells increased linearly (Fig. 4A, paper I). To get a measure of the cell surface affinity which can correlate to such synergistic binding, we compared an experimentally determined lactose inhibition curve with several theoretical ones. The possibility of galectin-8 binding only to high affinity (~10 nM) receptors present on the cell surface in large amounts was ruled out due to completely different shapes and locations of the curves. However, a theoretical curve corresponding to receptors with an average affinity of ~50 nM (and ~15 million of them) was close to the experimentally determined curves for both galectin-8s (long or short linker) (Fig. 4B, paper I). Considering the glycosidic cluster effect discussed above, it's clear that a reasonable bad fit (low cluster effect) of two moderate or even low affinity glycans bound by the domains (e.g. ~10 μ M for the N-CRD and 50 μ M for the C-CRD) suffice to generate a cell surface affinity of 50 nM. Thus, high affinity binding by intact galectin-8 to a cell surface does not require the best ligands for either CRD. By analogous analysis, cell surface affinity of either CRD was estimated at K_d above 200 nM (and for most ligands above 1 μ M) and can thus be explained by the monovalent affinities measured in solution.

CHO cell mutants, tools in determining specificity to cells

As reviewed in the introduction, all cells display a great variety of glycans on their cell surface, built by the collection of glycosyltransferases present in each cell. Over the years, many laboratories have isolated stable glycosylation-defective cell lines [150], with one of the largest collection of mutants on the background of Chinese hamster ovary (CHO) cells [151]. These CHO mutants have been selected for their resistance to toxic plant lectins (such as wheat germ agglutinin, ricin, and leucoagglutinin from *Phaseolus Vulgaris*), a resistance which arises from altered display of cell surface carbohydrates (to which the toxic lectin cannot bind). Also non-toxic lectins or carbohydrate specific antibodies can be used in the selection if they are coupled to a toxic subunit e.g. ricin A chain, or in combination with complement to induce toxic effects [150]. The glycosylation of the mutants has been thoroughly investigated and lectin-resistance phenotypes have been characterized. In most cases the genetic mutation has also been determined, and is either of loss-of-function (mutants named Lec) or gain-of-function type (mutants named LEC). Most mutations affect N- and O-glycosylation, but glycolipids, glycosaminoglycans, and GPI-anchors can also be defective. Depending on which glycosylation related enzyme is affected, the effect can be of more general type (affecting N-linked glycans, O-linked glycans, and glycolipids, e.g. Lec2, Lec8) or more restricted (affecting only a specific branch of an N-glycosylation e.g. Lec4, LEC10) [151].

Glycosylation defective cell mutants have not only been useful in cloning and characterization of glycosylation genes but have also contributed to more functional aspects of glycobiology [151]. Mutants have been the basis for identification of new CDG subgroups [152], evaluation of the role of glycans in Notch-signaling [153], or identification of O-mannose requirement on α -dystroglycan for virus entry [154], to mention a few. The mutants are also useful in the study of lectin specificity in a natural environment (paper II). For comprehensive listing of the glycosylation mutants in CHO to date, please refer to [151].

Parental CHO glycosylation

CHO cells have many N-glycans, mainly of the ‘complex’ and ‘high mannose’ type, and few ‘hybrid’ structures [155]. Several species of O-glycans are also present; mucin type with up to four monosaccharides without core 2 structures [156], O-fucose [157], O-glucose [157], and O-mannose [158], in addition to a few polysialic acid containing glycoproteins [159]. The major glycolipid is GM₃ (Neu₅Ac α -3Gal β -1-3Glc β -Cer) [160, 161], and CHO cells also produce glycosaminoglycans (heparan sulfate and chondroitin sulfate) [162]. CHO cells express no or very little glycosyltransferases that transfer α -1-2, α -1-3, or α -1-4 linked fucose [163], α -2-6-SA [156], or bisecting GlcNAc [164]. They also lack all glycan sulfations due to lack of sulfotransferases [165], except for those found in the glycosaminoglycans [162].

Galectin-8 fine specificity is not required for binding to cell surfaces

CHO cell mutants provide a variety of glycosylation profiles in their natural (and more complex) context; as part of various glycoproteins and -lipids on the membrane, and presented together in a mixture. This is an essential complement to the biochemical studies of binding specificity describes earlier. In our study, binding of 6 FITC-labeled galectins and galectin CRDs to a selection of 12 mutants (Figure 4 and Table I, paper II) were analyzed using flow cytometry. The effect of glycosylation was estimated by comparing the geometric mean of fluorescence for each galectin with its binding to wild type cells. This thesis will only discuss the specificity of galectin-8 (long and short isoform) and its two CRDs, for binding of galectins-1 and -3 to CHO cell mutants please refer to paper II.

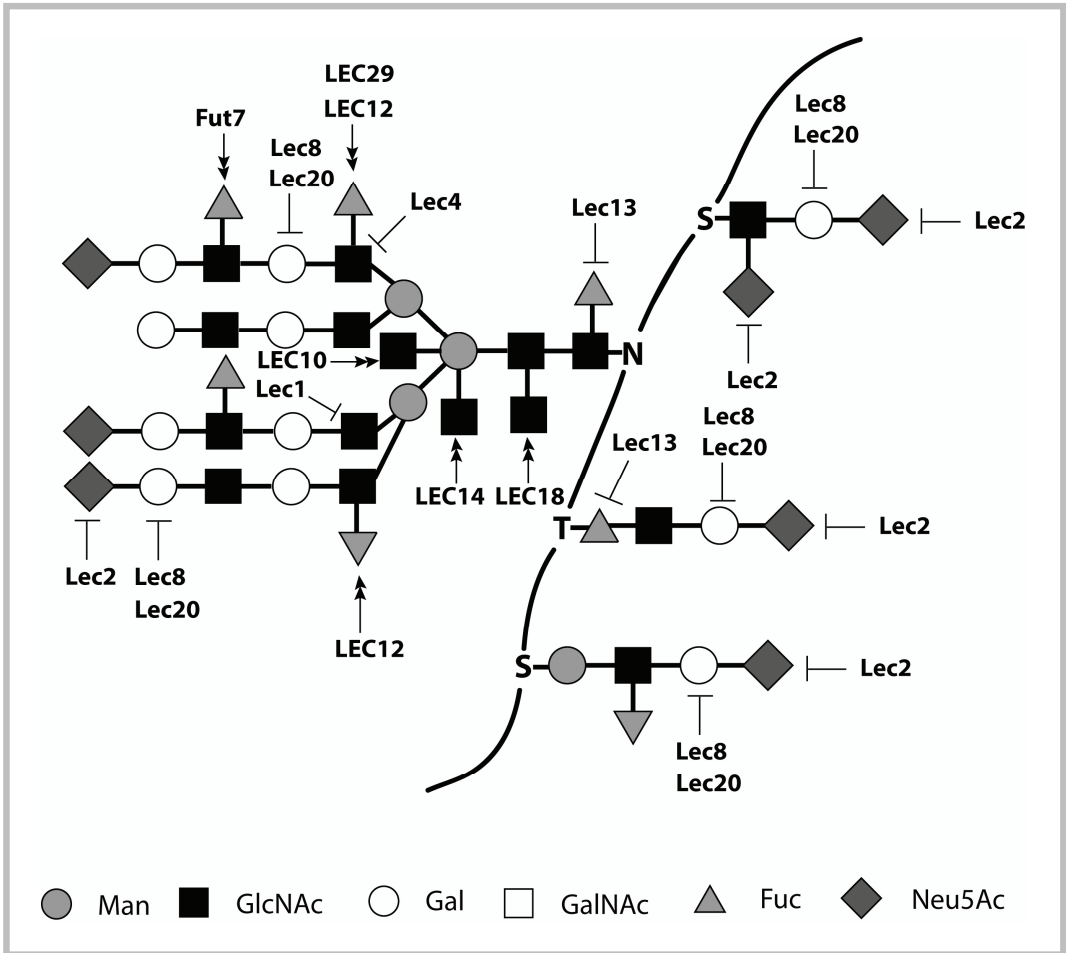

Figure 4 CHO glycosylation mutants. Illustration of the various glycosylation mutants tested with galectins-1, -3 and -8 in paper II. The effect on N-glycans (left) and various O-linked glycans (right: top, mucin type; center, O-fucosylation; bottom, O-mannosylation) are shown. Double-headed arrow marks gain of sugar residue while —| marks loss or reduction of sugar residues. The main form of glycolipid on CHO cells, GM3, is affected in mutants defect in transport or synthesis of CMP-SA (Lec2) or UDP-Gal (Lec8). The amino acids bearing the glycan are denoted with their one-letter code.

Parent CHO cells bound both isoforms of galectin-8 (long linker, G8L, and short linker, G8S, $\sim 0.3 \mu\text{M}$) and the N-CRD (G8N, $\sim 0.6 \mu\text{M}$) well enough for comparisons with mutants, although G8N binding was only moderate as compared to the strong binding of G8S and -L. Binding of the C-CRD (G8C, $\sim 0.6 \mu\text{M}$) did not result in a high enough signal to be investigated further (Fig. 1, paper II). As expected, no galectins bound the surface of Lec8 cells (deficient in a Golgi UDP-Gal transporter), completely lacking galactose at the cell surface. Lack of sialylations (on both glycoproteins and glycolipids) as in the CMP-SA transporter deficient Lec2, would be expected to have a profound effect on galectin-8 binding, seeing that $\alpha 2$ -3sialic acids is the by far best ligand for the N-CRD (see above). Hardly any effect was seen, however, on binding of intact G8S or G8L to Lec2 cells (Fig. 2, paper II), despite the fact that the binding of G8N was reduced to background level. A similar effect was seen after neuraminidase treatment of U937 cells (removing either $\alpha 2$ -3SA only or SA in all common SA-linkages) (Fig. 3, paper I). Binding of G8C increased to neuraminidase treated cells (an effect observed also with CHO cells), which is in accordance with the preference for non-sialylated saccharides by G8C determined by both FP and glycan array. Although binding of intact galectin-8 to cells did not require cell surface sialylation, presence of hybrid and/or complex N-glycans were required. Lec1 cells, which lack such glycans due to mutation in the *Mgat1* gene, showed no binding of intact galectin-8. Interestingly, despite the lack of N-glycans, G8N bound Lec1 with unaffected strength. These results suggest that normal levels of non-affected glycoconjugates, such as the glycolipid GM3 or sialylated O-glycans, are sufficient to mediate binding of G8N (Fig. 2, paper II). A high affinity binding to GM3 has been shown by Ideo and colleagues [127].

Core fucosylation (a fucose on the first asparagine-linked GlcNAc in N-glycans) had little effect on galectin-8 binding. Increased number of $\alpha 1$ -3-fucosylation slightly decreased binding when expressed internally on polyLacNAc residues (-Gal $\beta 1$ -4(Fuc $\alpha 1$ -3)GlcNAc-) or terminally as sialyl-Lewis^x epitopes (sLe^x, SA $\alpha 2$ -3Gal $\beta 1$ -4(Fuc $\alpha 1$ -3)GlcNAc-) (Fig. 3, paper II) (mutations are depicted in Figure 4). Altered N-glycan branching had various effects on galectin-8. While removal of the upper $\beta 1$ -6-branch on N-glycans on Lec4 cells (*Mgat5* deletion leads to loss of GlcNAc-transferase V activity) did not alter G8S or -L, it increased binding of G8N somewhat. Introduction of a bisecting GlcNAc (in LEC10) slightly decreased binding for all G8s, while an extra GlcNAc on the core $\beta 1$ -4mannose (in LEC14) increased binding of G8L slightly. Both G8S and G8L also increased binding a little to N-glycans with an extra $\alpha/\beta 1$ -6-linked GlcNAc on its core GlcNAcs (LEC18, Fig. 4, paper II).

Cell surface binding experiments with CHO glycosylation mutants showed that N-glycans are essential for cell binding of intact galectin-8s (G8S and -L), demonstrated by the lost binding to Lec1 cells, in spite of the unaltered binding of G8N to these cells (Fig. 2, paper II). CHO cell experiments also confirmed the N-CRD specificity to α 2-3-sialylated structures such as Neu5Ac α 2-3Lac as found in the glycolipid GM₃ and Neu5Ac α 2-3Gal β 1-3GalNAc as found in core 1 structures of O-linked glycans, although they also showed that such high affinity binding is not essential for synergistic binding of intact galectin-8 to occur. This fact is best illustrated by the unaltered (and strong) binding of intact galectin-8 to Lec2, a cell which did not bind the N-CRD, and only weakly bound the C-CRD at the concentrations tested (Fig. 2, paper II). In addition, lactose inhibition experiments of neuraminidase treated cells showed no difference in galectin-8 cell surface affinity as compared to non-treated cells (Fig. 4B, paper I). Taken together, these data argues that cell surface binding specificity of galectin-8 is rather broad, and is not dependent on the fine specificity of the separate CRDs.

Cellular effects of protein-carbohydrate interactions

The finding that cell surface binding of galectin-8 was rather broad, and not dependent on the unique preference of the N-CRD to sialylated and sulfated glycans, was in one way somewhat disappointing, but mostly puzzling. Why has nature bothered to preserve this specific galectin-8 feature all those years, at least since we diverged from our frog ancestor (see below) if it does not serve a function? The answer to the question is, of course, that there is a reason for its preservation; we have just not figured it out yet! We continued our investigation by testing the effect of galectin-8 on two different cellular responses which are elicited upon cell surface receptor engagement: neutrophil activation and endocytosis.

No altered activation of neutrophils by G8S Q47A

As mentioned in the introduction, neutrophil oxidative burst is pivotal for neutrophil function in innate immunity, and is a response elicited by intact galectin-8 [80] (Fig. 5, paper I). G8S and G8L induced release of reactive oxygen species both extracellularly (by activation of NADPH-oxidase sitting in the plasma membrane) and intracellularly (by activation of NADPH-oxidase in the membranes of specific granules) in LPS or TNF- α primed neutrophils. For the extracellular response, G8S was the more potent of the two galectins inducing a larger release of O₂⁻ at lower concentration. For the intracellular response, however, there was no difference between the two isoforms. To test if the galectin-8 effect was mainly mediated via receptors bearing α 2-3-linked sialic acid, we tested a mutant of G8S with drastically decreased affinity for 3'SA and 3'sulfate (G8S Q47A, [127], Table III, paper I). There was not much difference in neutrophil activation between G8S and the mutant, although the mutant might have been slightly less potent in the extracellular response (Fig. 5C, paper I). In addition, lactose inhibition of the response did not differ at all between them, suggesting that there was no major difference in affinity of the cell surface receptors involved either. In conclusion, the fine specificity of galectin-8 for α 2-3-SA is of minor importance in activation of oxidative burst in primed neutrophils.

Endocytosis

For an organism to function as an entity, a constant communication between all cells is indispensable. The plasma membrane of each cell has a very central role in this communication, functioning as a 'switchboard' in receiving, sorting, and re-directing all incoming signals. Endocytosis, or cell uptake, is a very common cell response to extracellular stimuli, with functions in uptake of nutrients, growth factor signaling, regulation of surface receptors, and antigen presentation amongst others [166, 167]. Endocytosis can be divided into cell eating (phagocytosis) and cell drinking (pinocytosis) [166]. Phagocytosis of particles, such as bacteria or cell remnants, is restricted to a few specialized cell types including neutrophils, monocytes, and macrophages. The process can be illustrated by a zipper, for example in neutrophils where actin-driven cell protrusions enclose the particle and then fuse with the plasma membrane, resulting in particle uptake without simultaneous uptake of extracellular fluid [166, 167]. Complement coated particles are, in contrast, internalized in the absence of membrane protrusions, although also in the 'zipper-like' way [167]. Pinocytosis, on the other hand, is uptake of extracellular fluid in large amounts (macropinocytosis) or small amounts (micropinocytosis). The micropinocytosis can be further divided into several pathways; clathrin mediated endocytosis, caveolae-dependent endocytosis, and clathrin- and caveolae-independent endocytosis. The stimulus and/or the cell membrane receptor to which it interacts is the main regulator of which pathway is taken [166, 167], however, a single stimulus can induce signaling through more than one pathway. This has been shown for the epidermal growth factor (EGF) receptor which is internalized almost exclusively via clathrin-coated pits at low ligand concentrations (1.5 ng/ml), while a clathrin-independent and cholesterol-sensitive pathway mediates internalization at high ligand concentrations (20 ng/ml) [168]. The latter pathway also correlates with EGF receptor monoubiquitination. Similarly, transforming growth factor (TGF) β can be internalized via either clathrin-coated pits or caveolae. The various endocytic routes used for TGF β elicit distinct signals leading to propagation of the signal (clathrin) or to receptor degradation (caveolae) [169]. Despite the highly specific effects mediated upon receptor engagement and activation of a certain pinocytic event, several cellular mechanisms are shared between the pathways, and cargo (endocytosed ligand) from one way of entry can end up in the same endosomal compartment as cargo from another [170]. The actin cytoskeleton, membrane rafts, and dynamin are three examples of commonly used 'molecular machinery'. Thus, inhibition of an isolated pathway can in many cases be a difficult task [167].

Below is a short description of the four pinocytic events listed above. Due to the central role of membrane rafts in signaling and endocytosis, they are described in a fifth paragraph.

Membrane ruffles and macropinocytosis

Macropinocytosis occurs in most cells, although more constitutively in certain cell types, such as dendritic cells and macrophages, than in others [167, 171]. Membrane ruffling is intimately linked to formation of the large (1-5 μm), irregular vesicles called macropinosomes, which is the resulting structure formed when membrane protrusions collapse upon and fuse with the plasma membrane. Although seemingly uncontrolled, ruffling and macropinocytosis is highly regulated events induced by growth factors and phorbol esters [166, 171]. Platelet derived growth factor (PDGF)-induced activation of the small GTPase Rac1 and its downstream effectors p21-activated kinase (PAK) and phosphoinositid 3-kinase (PI3K), is one example of signals rearranging the actin cytoskeleton, and hence affects the formation of ruffles [166, 167, 171]. In addition, cholesterol is essential for membrane localization of activated Rac1 [172], which makes macropinocytosis a process sensitive for cholesterol depletion and actin disrupting agents such as cytochalasins [167, 170, 172]. Another commonly used drug to target this bulk uptake mechanism is amiloride (and derivatives), which acidifies the cytosol as a result of Na^+/H^+ pump inhibition [171, 173]. Most endocytic routes require dynamin to separate the budding vesicle from the plasma membrane [170]. Although macropinocytosis does not involve dynamin, a novel alternative fission machinery with C-terminal binding protein-3/brefeldin A-ribosylated substrate (CtBP3/BARS) in a key position was recently proposed to be active in fluid phase uptake of fluorescently labeled dextran [174].

Macropinocytosis leads to the internalization of significant volumes of extracellular fluid together with large areas of membranes. Besides a role in downregulation of signaling molecules and receptors, macropinocytosis has an immune modulatory role by dendritic cell ingestion and display of antigenic peptides on MHC class I and II [167, 171]. Also some bacteria have been found to use the 'spacious phagocytosis' of macropinocytosis as a point of entry into cells [167].

Clathrin-mediated endocytosis

Clathrin mediated endocytosis (CME) is the best understood of the endocytic pathways and occurs constitutively in all mammalian cells. It provides a basis for numerous essential cellular activities such as nutritional uptake (of e.g. cholesterol-loaded LDL or iron-loaded transferrin), modulation of signaling (via regulation of available cell surface receptors), and cell homeostasis (by regulation of membrane channels responsible for small molecule- and ion-uptake). Its role in synaptic vesicle recycling has fundamental impact on the function of the nerve system, including behavior and memory [166, 175]. CME is a complex process which requires a remarkable level of choreography of numerous participating proteins, both temporally and spatially [176]. In short, the process can be described by (i) assembly of coated pits, (ii) invagination of the membrane, (iii) separation of the budding vesicle from the membrane

(fission), and (iv) movement of the formed endosome to its intracellular destination [166]. Extracellular receptor ligation initiates the formation of the 'coated pit', where the three-legged protein clathrin starts to assemble at the site of adaptor protein complex (APs) on the cytoplasmic side of the membrane. Adaptor protein complexes are heterotetramers with two large subunits (γ/β_1 , α/β_2 , δ/β_3 and ϵ/β_4 in APs 1-4 respectively), a medium μ -subunit (1-4) and a small σ -subunit (1-4). While the α - ϵ subunit targets the complex to a subcellular location (e.g. the plasma membrane for AP-2 with its α -subunit), the μ -domain recognizes a sorting motif on cytoplasmic tail of the liganded receptor and is responsible for its binding and concentration in the forming pit [166, 177]. Membrane curvature and subsequent fission is accomplished by a combined effort of a number of accessory proteins. Clathrin, amphiphysin, Eps15 and epsin are a few participants in the formation of the vesicle interacting with each other and with the plasma membrane. The fission machinery includes several additional proteins (e.g. cortactin, N-WASP, Arp2/3, syndapin) responsible for interaction with the actin cytoskeleton and for the fission-event itself [176, 177]. The GTPase dynamin forms a 'collar' around the neck of the forming vesicle and is required for separation of the vesicle from the membrane. The exact details of how this is accomplished are not known, the main contemporary theories suggest either a 'pinching off' mechanism, in which dynamin constricts the neck until the two separates, or a 'popping' mechanism, in which the spiral-formed dynamin functions as a molecular spring [166]. Interaction with a dynamic actin cytoskeleton plays a major role in CME, and drugs both stabilizing and disassembling actin inhibits endocytosis. Besides the essential contacts required during fission, a role for actin in the organization/initiation of the endocytic site, as well as in the movement of the formed endosome to the intracellular 'rail road' of microtubuli, have also been suggested [176]. Approaches used to inhibit CME include more specific ones, such as dominant negative forms of Eps15 and inhibitors of the assembly of AP-2 complex (e.g. the antipsychotic drug chlorpromazine) [178], as well as broader endocytic targeting using dominant negative forms of dynamin or actin destabilizing drugs. CME is also sensitive to acidification of the cytoplasm.

Membrane rafts

The existence of plasma membrane domains with functions in sorting and signaling has been debated from when they were first suggested in the 1980's [179] until today [180]. Although most researchers agree that a lateral heterogeneity is a requirement in the function of biological membranes, the proposed domain's small size (below the physical limit of detection of most techniques), and highly dynamic appearance has prohibited emergence of compelling evidence for the 'true nature' of these important structures [181]. The complexity of the field has been (and still is) great and the views describing these raft domains are many. Therefore, a definition was generated by the participants of the 2006 Keystone Symposia on Lipid Rafts: "Membrane rafts are

small (10-200 nm), heterogeneous, highly dynamic, sterol- and sphingolipid-enriched domains that compartmentalize cellular processes. Small rafts can sometimes be stabilized to form larger platforms through protein-protein and protein-lipid interactions.” [182]. Glycans are tightly connected with membrane rafts through their enrichment in glycosphingolipids and GPI-anchored proteins [170]. The formerly used term ‘lipid raft’ was abandoned to reflect the complex network of lipid and protein interactions that together are the driving force in the formation of rafts, and not the sole effort of lipid physical properties as previously believed [182]. It is also important to remember that artificial membranes, on which many raft studies have been performed, are quite different from biological membranes, mainly due to the high density of proteins (30-32,000 per μm^2) in biological membranes which allows only a few rings of lipids between each transmembrane protein [181]. This is in contrast to the simplified picture of a raft floating in a ‘sea’ of lipids in many articles. Further, the formerly used method of detergent resistance to identify rafts and constituents thereof was considered misleading, since extraction of lipids bring spatially unrelated components together in a non-physiological way [181, 182]. The field of rafts has been moving towards a shell-hypothesis where small clusters of proteins (<10 nm), surrounded by a ‘shell’ of cholesterol and sphingolipids, are free moving entities in the plane of the membrane able to target membrane rafts or be triggered to aggregate by external influences [181, 183]. Such a model would give raft signaling high efficiency and a large dynamic range, enabling control of formation of large platforms and thresholding of signals [184]. Examples of large platforms are the immunological synapse and the intestinal brush border membrane [182].

Rafts are implicated in a number of signaling events and sorting of membrane proteins [184]. Cholesterol depletion, by treatment with agents such as methyl- β -cyclodextrin, is commonly used to indicate raft dependency. However, as rafts are key structures in the aggregation of signaling molecules all endocytic pathways are sensitive to cholesterol depletion, from macropinocytosis and CME to clathrin and caveolae-independent pathways [170]. Cholesterol depletion has also been shown to decrease the membrane content of phosphatidylinositol-4,5-bisphosphate (PI(4,5)P₂), with the consequence of a globally upset actin cytoskeleton regulation instead of a local inhibitory effect [185]. Therefore, cholesterol may be required for lateral membrane mobility and protein aggregation in general, rather than specifically for formation of membrane rafts.

Caveolae and endocytosis

Although caveolae is frequently mentioned as a route of cell internalization, and in most cases as the (only) raft mediated pathway [186], the physiological role of caveolae is still under debate [187, 188]. Caveolae is one of several raft subpopulations mediating cellular effects, but emerging data questions its role

as endocytic carrier in the favor for more efficient raft-mediated uptake mechanisms functioning in parallel (e.g. CME and others described under clathrin- and caveolae-independent endocytosis) [182, 187, 188]. Caveolae are abundant structures in the membranes of adipocytes, endothelial cells, fibroblasts and smooth muscle cells, whereas they are absent in other cell types e.g. lymphocytes. Their dysfunction has been associated with human disease as breast cancer and muscular disorders [188]. Caveolae are flask-shaped, coated, cell membrane invaginations, 60-80 nm in diameter, found either as single entities or in branched clusters [188, 189]. Caveolin is the main constituent of the coat and is a horse-shoe shaped protein with a membrane-interacting 'loop' and two cytoplasmic terminals. Caveolin interacts directly with cholesterol in cholesterol/sphingolipid enriched rafts (located on the outer leaflet of the plasma membrane), and membrane cholesterol depletion flattens caveolae [170, 188]. Although depletion of cholesterol is frequently used to show involvement of caveolae in endocytic and signaling events, this method is rather non-specific, as discussed above. Caveolae are highly stable structures intimately connected with the actin cytoskeleton and have very little lateral movement [187, 188]. Their turnover is suggested to be negatively regulated by caveolin rather than promoted [170, 187, 190], and only a small fraction of caveolae are thought to bypass this restriction and pinch off as a vesicle (in a dynamin dependent way). Internalization can be triggered by bacterial toxins or viruses binding to the glycolipid GM1, however, both cholera toxin and SV40 viruses have alternative routes of internalization [187]. The signals regulating caveolae are presently unknown, although phosphorylation/dephosphorylation and the balance between caveolin and glycolipids have been suggested [170, 187].

Caveolae have been linked to cell signaling in numerous papers, of which most should be regarded with some skepticism due to the difficulty to satisfactorily prove that signaling molecules really reside in caveolae. Despite this caveat, caveolae are required for activity of endothelial nitric-oxide synthase (eNOS), and important for cholesterol trafficking and lipid regulation; *in vivo* studies have indicated caveolae as a sensor of flow in blood vessels, and in muscle cells mechanosensing [188].

Clathrin- and caveolae-independent endocytosis

The most unknown mechanisms of cell internalization are the ones (two or more) independent of both clathrin and caveolae. These CLICs (CLathrin Independent Carriers) display a dependence on a selection of the machinery shared with other pathways, and an independence on yet other participants [170]. Membrane rafts play a central role as most (if not all) are sensitive to cholesterol depletion/sequestration [189, 191-193]. Classic markers for rafts are the GPI-anchored proteins, of which the folate receptor (FR), decay-accelerating-factor (DAF), and GPI-GFP were internalized in a clathrin/caveolae independent, dynamin independent but Rho GTPase (cdc42 but not RhoA)

regulated way [192]. Other molecules taken up into cells in a dynamin independent way are cholera toxin and HIV-1 [189, 193]. Both GPI-anchored proteins and cholera toxin were targeted to a novel compartment named GEEC (GPI-anchored protein Enriched Early endosomal Compartments) by Sabharanjak and coworkers, distinct from the regular early endosomal compartment in CME [189, 192]. Fluid-phase markers (e.g. dextran) were also co-localizing in these tubular/ring shaped structures lacking Rab5, a molecule normally characterizing CME early endosomes. Although CLIC and CME differ during the early intracellular trafficking, both co-localize during later stages e.g. when GPI-anchored proteins and transferrin (another CME-marker) both are found in recycling endosomes [192].

Interleukin 2 and its receptor is another example of an endocytosis mechanism independent of both clathrin and caveolae. However, the cellular machinery mediating this uptake is in contrast to the above mentioned examples dependent on dynamin [191], which also uptake of the cytokine receptor subunit γ_c is [194]. It is very likely that CLICs are interacting with and/or are dependent on the actin cytoskeleton, just like CME and the other endocytic pathways, although it has not been shown for most of them. γ_c , for example, required interaction with actin through a protein found in the clathrin machinery, cortactin (but not intersectin, syndapin or mAbp1). Interaction was mediated through the cortactin Arp3-binding domain and was the first report showing a link between and clathrin independent endocytosis and actin dynamics [194].

Fine specificity of galectin-8 determines intracellular targeting

Endocytosis experiments with galectin-8 clearly showed that this galectin was taken up into various cell types in a temperature dependent manner, as analyzed by confocal microscopy and flow cytometry (Fig.1 and Fig.2, paper III). Cell surface affinity seemed to be a determinant of how much galectin was internalized since it regulates the amount of galectin that bind the surface. Thus, fairly similar amounts of internalized galectins could be observed by flow cytometry when various amounts of galectin-8 proteins were added (G8S, 0.5 μ M; G8L, 0.5 μ M; G8N, 5 μ M; G8C, 5 μ M), which all aimed at generating a strong cell surface binding. The slight uptake of FITC-labeled thioredoxin (a protein all galectin-8 variants are fused with to increase their solubility) indicated a low degree of non-receptor mediated endocytosis working in parallel, as this protein does not bind to cells (not shown, paper I).

In an attempt to determine the underlying mechanism of this endocytosis we treated cells with four different drugs prior to incubation with galectin-8. Drugs tested were methyl- β -cyclodextrin (to remove cholesterol), amiloride (to inhibit

macropinocytosis), chlorpromazine (to inhibit CME), and cytochalasin D (to inhibit actin rearrangements), which are broad acting drugs inhibiting several endocytic pathways (see above). However, (and slightly surprising) neither of the drugs inhibited intracellular accumulation of galectin-8 (Fig. 3, paper III), even if some grossly affected overall cell morphology. Hence, no conclusions can be drawn of what pathways are responsible for galectin-8 uptake and further studies using more specific tools are required to dissect the molecular machinery mediating this effect.

Most interestingly, despite the fact that galectin-8 binds highly similarly to cell surfaces with or without α 2-3-linked sialic acid, this fine specificity determines the intracellular targeting of endocytosed galectin-8. Incubating G8S with wild type (wt) CHO cells (i.e. parental CHO for 30 minutes) resulted in a pattern where galectin-8 was found in intracellular vesicles and in a perinuclear structure, as well as on the cell surface (Fig. 1, paper III). In contrast, incubating G8S with the CHO mutant Lec2 (lacking all sialylations), resulted in no cell surface stain and all galectin-8 resided in evenly distributed cytoplasmic vesicles. The surface distribution of G8S in wt CHO could be a result of a recycling event, in which endocytosed galectin gets redirected to the plasma membrane after internalization. A defect recycling route in Lec2 could be one explanation for the difference in intracellular distribution observed between the two cells. The G8S mutant with decreased binding to sialic acid (G8S Q47A, see above, [127], paper I) showed that this, however, was not the case. The highly similar cell distribution of G8S Q47A in wt CHO cells as for G8S in Lec2 (intracellular vesicles in addition to plasma membrane staining) clearly showed that the α 2-3 sialic acid is responsible for the intracellular targeting of G8S. Moreover, the mutant showed that other cell surface receptors without sialic acid, in complex with a galectin preferring them (G8S Q47A, see below), could direct endocytosed protein into the recycling route since it gave a similar pattern with Lec2 cells as G8S did with wt CHO cells (Fig. 1, paper III). The increased affinity of G8S Q47A for GlcNAc-extended glycans (as GlcNAc β 1-3Gal β 1-4Glc, or LNnT) (Table I, paper III), in addition to altered glycan structures on Lec2 bearing such terminals can explain this effect. Further studies are needed to pinpoint the exact glycan structures responsible.

Endocytosis experiments using galectin-3 only partially overlapped with the intracellular distribution of galectin-8 (Fig. 1B, paper III). For example, galectin-3 is not at all visible at the cell surface, and resides entirely in intracellular structures, where it colocalizes with galectin-8 mainly in the perinuclear compartment but not in intracellular vesicles. Galectin-3 uptake into Lec2 was largely decreased and effect of sialylation on its endocytosis could not be evaluated. This data further strengthen the relationship between galectin fine specificity and intracellular targeting.

Concluding Remarks

Galectins, as one of the largest families of glycan-deciphering lectins known today, are increasingly reported in various normal and pathological conditions. However, there is a lack of understanding in how the separate members, each with a distinct profile of preferred glycans, are mediating their effects. Presented in this thesis are data which connects the characteristic fine specificity of galectin-8 with its effects on cell surface binding and intracellular targeting. It is shown that at the cell surface galectin-8 appears to have, surprisingly, a rather broad specificity combining ligands of moderate affinity for its two CRDs. Highly selective ligands for the N-CRD instead appear to decide the intracellular fate of galectin-8.

Understanding the basis of specificity of glycan-protein interactions is one of the challenges ahead in glycobiology and glycomics [27]. By combining glycan array analysis, which simultaneously tests almost 300 glycans, with the in solution based fluorescence polarization assay, giving affinity constants and binding mode for a selection of glycans, we investigated the details of galectin-8 specificity. Our results both confirmed the previous reported specificities for the N- and C-CRD [38, 127] and expanded them as a result of the larger number of glycans tested.

The most striking finding, observed in all three investigations, was the unusually strong affinity of the N-CRD to α 2-3 sialylated and 3'sulphated β -galactosides. This preference is unique for galectin-8 and seems evolutionary conserved since it is retained in the frog orthologue (unpublished data). With FP, we could also show how the high monovalent affinity is achieved, by addition of several fragments (such as Glc, Neu5Ac and fluorescein-linker) to a single galactose tightly bound in site C of the galectin CRD (paper I). Considering our approximate cell surface affinity estimation for G8N, and the affinity of the same to immobilized glycolipids (containing 3'sulfation or sialic acid) shown by Ideo and colleagues [127], it is not at all unlikely that glycolipids might be a major cell surface ligand for the N-CRD *in vivo*. In support for this hypothesis is the fully retained binding of G8N to CHO cells completely lacking complex N-glycans (Lec1) (paper II). In addition, although weak and sparse, clear spots of galectin-8 could be seen in the endocytosis experiments with G8S to the same CHO mutant (Fig. 1A enlargement, paper I). Such spots were not visible with the G8S Q47A mutant, strongly indicating that the effect was

mediated by α -3 sialic acids on glycolipids or O-glycans (which are unaltered on this glycosylation mutant). The involvement of sulfated glycolipids can be ruled out since CHO cells do not express any sulfotransferase [165].

The C-CRD showed an overall lower affinity to most glycans (Table I, paper I), and low signals on both glycan array and binding to CHO cells were obtained, making the C-CRD the hardest galectin-8 protein to evaluate. A-tetra saccharides (and some B-tetras) were shown to be the preferred epitopes, in addition to elongated structures such as LNnT (paper I) [38, 127]. Despite the difference in affinity between the two galectin-8 CRDs, the C-CRD is not to be disregarded or forgotten. Its importance in the cell surface binding of intact galectin-8 is striking, exemplified by a cell surface binding of intact G8S and -L reduced to near background on CHO cells lacking complex N-glycans, despite retained N-CRD binding (see above). Thus, galectin-8 is most probably highly dependent on the glycosidic cluster effect in combination with the fine specificity in exerting its extracellular (and intracellular?) effects during physiological conditions.

Crosslinking of ligands is central in the induction of cellular responses by galectins. Galectin-1, for example, induces lattice formation of CD43/CD7 or CD45/CD3 on T-cells (CD43 is never co-clustered with CD45), where the clustering of CD43 is believed to push cells into apoptosis [7, 49]. Another example is galectin-3, which has been suggested to form a lattice with the T-cell receptor, and thereby regulate its signaling [51]. When the two galectins are added to the same T-cell, their fine specificities direct them to (at least in part) separate glycoconjugates. Galectin-3, for example, aggregates the transferrin receptor (CD71) on T-cells when galectin-1 crosslinks CD45, although galectin-3 has affinity for both CD45 and the transferrin receptor [195]. Bi-CRD galectins have two distinct glycan-binding domains and they are much more likely to bind two unrelated ligands (e.g. CD45 and CD43) *in vivo*. Regarding the fine specificities of the galectin-8 domains, this bi-CRD galectin could very well cluster glycolipids, via the N-CRD, with glycoproteins, via the C-CRD. The flexible linker and glycosidic cluster effect enables good binding of intact galectin-8 to multiple receptor pairs, ensuring cell surface binding to most normally glycosylated cells. However, the linker can also be of regulatory function when being enzymatically cleaved, resulting both in loss of cluster effect and generation of competitive inhibitors (the separate CRDs). Recent data on galectin-9 are in favor for such a regulatory role as the galectin-9 linker (including the galectin-8 one) has been shown sensitive to certain enzymes [99, 100]. In addition, the chemoattractant activity of galectin-9 does not seem to require a linker at all, although two CRDs are essential [196].

Upon addition to cells, the first encounter of galectin-8 is likely a sialylated LacNAc displayed on the very tip of extended glycans (such as N-, or O-glycans), to which the N-CRD can interact with high affinity. Thus, binding of the N-CRD to an α 2-3-sialylated LacNAc, simultaneously with the C-CRD interacting with another part of the same glycan, or a glycan closely nearby, could establish a first cell interaction. However, with the variety of glycans densely displayed on a cell surface, and considering the non-requirement of fine specificity in retaining a high affinity to the cell surface, it is possible that the N-CRD and C-CRD shifts glycan ligands during their time bound to the cell surface. This would result in a final binding to a ligand-pair with maximal affinity (through binding to the best ligands for both the N- and the C-CRD), as compared with the ligands bound in the first place. Supportive for such an idea, is the 10 times weaker affinity of the N-CRD for 3'sialylated LacNAc as compared with 3'sialylated (or 3'sulfated) Lac or Gal β 1-3GalNAc (Table I, paper I). The weaker affinity of sialylated LacNAc would be strong enough to mediate initial contact to the cell, but also weak enough to permit subsequent shifting. Also, considering the length and flexibility of glycan chains on the cell membrane, longer extensions of e.g. glycoproteins will most probably hide shorter glycans situated close to the cell surface, exemplified by GM₃ (3'SA-Lac) or sialylated core 1 structures on O-glycans (3'SA-Gal β 1-3GalNAc). Another possibility for extracellular added galectin-8 to reach the short glycans of e.g. GM₃ (than the one proposed above), is if these glycoconjugates are already present in a preformed membrane patch, creating a space devoid of long glycans, almost like a glade in the woods. To me, galectin-8 would rather be the creator of the 'glade in the woods', by crosslinking glycoproteins with short glycolipids, than the opposite. However, both are of course possible.

Galectin-8 crosslinking of certain membrane receptors triggers its endocytosis into the cell and intracellular sorting (Figure 5A). This uptake seems to be of a non-classical type since neither of the tested inhibitors hindered accumulation of galectin-8 inside the cell. Irrespective of the underlying mechanism, galectin-8 is recycled back to the cell surface simultaneously as being present in intracellular structures, when receptors containing 3'SA are present on the cells. From our results it's unclear whether galectin-8 acts as a 'driver' or a 'passenger' in the observed intracellular targeting. Galectin-3 and -4 are examples of 'driver' in vesicular transport [44, 74]. This is characterized by a requirement of their presence for a correct sorting of outbound vesicles, and hence, their removal distorts the normal delivery. Previous reports have suggested terminal sialic acids as a sorting signal for apical delivery in polarized cells [197, 198], which opens the possibility for cooperation with galectin-8 in this sorting. However, galectin-8 could also be a 'passenger', directed to the same location as sialic acid containing receptors by its strong affinity for such glycans. In the latter scenario, the fine specificity of the C-CRD could be the physiological important one, recruiting specific glycoprotein receptors of unknown function to the same location.

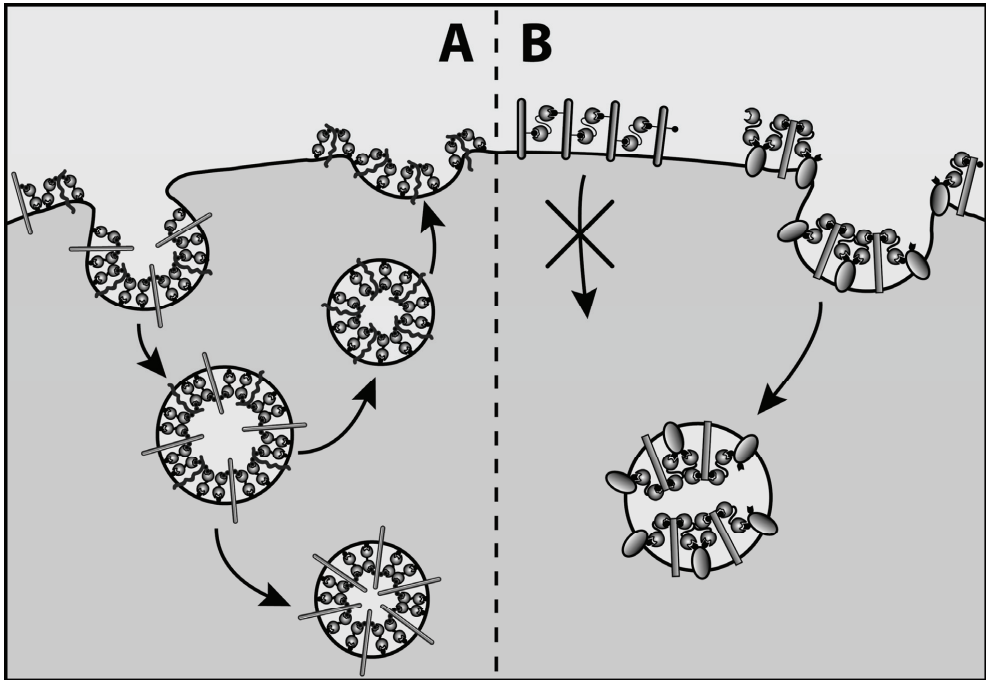

Figure 5 Galectin-8 endocytosis. Illustration depicting the two hypotheses on galectin-8 endocytosis, and how they could explain the cellular pattern of G8S observed in wt CHO cells. **A)** Galectin-8 crosslinks glycoproteins with glycolipids, which causes their clustering and elicits endocytosis. Inside the cell, sorting takes place and a subset of the receptors are trafficked to intracellular structures, while another subset (with sialic acid bearing glycans) is recycled back to the cell surface. Sorting could also occur at the cell surface, where galectin-8 crosslinking separates receptors from one another and trigger their internalization separately. The endocytic pathway taken by these receptors are different, one results in recycling of SA-bearing glycans back to the surface while vesicles from the other (with unknown glycans) remains intracellularly. **B)** Galectin-8 crosslinking separates cell surface receptors from each other. For one subset (containing SA-glycans), clustering inhibits their endocytosis, while for another subset endocytosis is triggered.

Crosslinking of cell membrane ligands could also induce lattice formation of specific receptors (Figure 5B), regulating their endocytosis and/or signaling, a function suggested for galectin-3 in endocytosis of cytokine receptors and T-cell receptor activation [51, 52]. Such a lattice formation could retain galectin-8 at the cell surface, as opposed the suggestion where galectin-8 is recycled back to the surface after internalization. The fact that galectin-8 is seen inside cells and not only at the cell surface could be explained by a thresholding mechanism. The first receptors to be bound by galectin-8 are the high affinity ones which forms the lattice. When these receptors are all occupied, excess galectin-8 would then bind secondary receptors, which are the ones responsible for triggering of endocytosis. This scenario proposes galectin-8 to be able to induce dual functions in the cell dependent on the extracellular concentration, similar to the dual endocytic routes reported for the EGF receptor and TGF β [168, 169]. The low concentration galectin-8 used in our experiments (0.5 μ M) argues against such a model in view of the abundance of GM3 on CHO cells, which are one of the best glycans for the N-terminal. The other possibility is that both lattice formation and triggering of endocytosis are elicited upon galectin-8 binding, without one receptor-galectin complex serving as a threshold for the other (Figure 5B).

Our work has generated valuable information of how glycan specificity in the two CRDs of galectin-8 is achieved, and has provided insight into how this specificity is connected with intracellular targeting. However, the role of galectin-8 in this effect is far from clear and we have generated more questions than we sought to answer from the start. Further experiments could reveal a fundamental cellular function of galectin-8, hopefully giving a clue to why galectin-8 is expressed in so many cells.

Populärvetenskaplig sammanfattning på svenska

Alla celler i en människokropp är uppbyggda av fyra olika byggstenar: DNA, fetter, proteiner samt socker. Glykobiologi är läran om socker och innefattar allt som har med dem att göra: hur de tillverkas, hur de ser ut, vad de har för funktion, hur de bryts ner etc.. Förutom att vara en energirik del av vår kost och orsak till en av våra vanligaste sjukdomar (diabetes, eller sockersjuka), så är sockermolekylerna i våra celler oumbärliga för att cellerna ska kunna fungera. Sockerstrukturerna sätts som en extra del på olika proteiner och fetter (lipider) och bildar på det viset glykokonjugat, s.k. glykoproteiner eller glykolipider. De finns till störst del på utsidan av våra celler och i blåsor inuti cellerna, men andra typer av glykosyleringar kan vi också hitta på proteiner i cellvätskan. Ett foster som inte kan tillverka vissa grundläggande sockerstrukturer aborteras tidigt och utvecklas aldrig vidare. Mindre drastiska effekter av felaktigheter i sockertillverkning återfinns specifika sjukdomar, dessa kan dock vara av mildare eller allvarligare typ.

Medan vår förståelse för andra molekylklasser är förhållandevis stor, så är kunskapen om glykobiologi fortfarande begränsad. Detta beror bland annat på att sockrets byggstenar (monosackarider) kan sättas samman i väldigt komplexa strukturer, samt att olika celler kan tillverka olika sockerstrukturer. Hur ett protein ska se ut avläses ur DNA och alla celler tillverkar en specifik proteinkejda på samma sätt eftersom DNAt finns i alla celler. Däremot finns det inget "recept" i en cell för hur sockerkonjugaten ska se ut, utan de beror på det urval av sockertillverknings-enzymerna som finns i just den cellen. Komplexiteten hos socker gör dem dock till utmärkta "informationsbärare", information som kroppen avläser via proteiner som kallas lektiner. De framtida utmaningar glykobiologifältet står inför är i huvudsak tre: (i) att förstå hur den enorma variabiliteten hos sockerstrukturer uppkommer genom att förstå hur tillverkningen av dem regleras, (ii) att förstå grunden för specificitet i protein-socker interaktioner (vilket är avgörande t.ex. för hur ett unikt lektin fungerar), samt (iii) att förstå hur ett protein som binder till fler än ett bindningsställe samtidigt ger upphov till signalering i cellerna och cell-cell-kommunikation genom en selektiv interaktion med ett urval av den enorma mängd socker som finns på en cellyta. Den här avhandlingen har försökt bidra med kunskap till de

två sista punkterna. Vi har klarlagt hur ett av människokroppens lektin, galektin-8, binder till specifika sockermolekyler och hur den specificiteten påverkar galektinets cellytebindning och cellulära effekter.

Galektiner är en familj av lektiner som är delaktiga i många basala funktioner i kroppen, t.ex. celltillväxt, celldöd, cellbindning till underlag m.m.. De kännetecknas av bindning till β -galaktosider, vilket är disackarider där den ena monosackariden är av typen galaktos, t.ex. i mjölksocker (laktos). Galektiner har antingen en sockerbindande domän (CRD, från engelskans carbohydrate recognition domain), eller två. Galektin-8 är ett typiskt två-CRD galektin och kan liknas vid en hantel, där själva greppet utgör länken mellan de två domänerna, som i sin tur motsvaras av de båda vikterna. Även om de flesta celler (både normala och cancerceller) tillverkar galektin-8 så är dess funktion fortfarande okänd.

Vi har med hjälp av två olika metoder visat att de båda domänerna i galektin-8 har väldigt olika specificitet och bindingsstyrka (affinitet) till olika sockerstrukturer. Den ena domänen (C-CRDn) föredrog sockerstrukturer som utgör blodgrupp A, och uppvisade en bindingsstyrka i mikromolar-området, vilket anses som en typisk affinitet för protein-socker-interaktioner. Den andra domänen, N-CRDn, band bäst till laktos med sialinsyra eller laktos med en sulfatgrupp på. Bindningsstyrkan mellan dessa var ovanligt stark för att vara en enkel protein-socker-interaktion, och uppmättes till ca 50 nanomolar.

Även till en cellyta uppförde de båda domänerna sig som förväntat med avseende på specificitet och bindingsstyrka. C-domänen band generellt sett mycket svagare än N-domänen, som i sin tur var beroende av närvaro av sialinsyra för att binda starkt. Intressant nog var det annorlunda för intakt galektin-8. Först och främst band galektin-8 mycket starkare till celler än de enskilda domänerna. Detta beror på att två sammanbundna domäner (som galektin-8 med sin hantelform) kan binda två olika sockerstrukturer samtidigt, vilket underlättar interaktionen och gör den starkare. För det andra visade sig intakt galektin-8 inte alls vara beroende av sockerstrukturer med sialinsyra för att kunna binda starkt. En stark cellytebindning av galektin-8 kunde även uppnås om cellerna bara hade sockerstrukturer som band "halvbra" till de enskilda domänerna, dock var det avgörande att båda band var sitt socker.

Även om det hade visat sig att specificiteten för sialinsyra hos N-domänen i galektin-8 inte var avgörande för cellytebindning av proteinet, så visade vi att den var av betydelse för var galektinet hamnar inuti cellen efter att det tagits upp från cellytan. För att utröna betydelsen av fyndet, och dess funktion i cellen, behöver vi göra fler experiment. Troligtvis rör det sig om en mekanism som är viktig för alla celler och fortatta studier hade kunnat vara väldigt givande.

De basala funktioner galektiner utför i en cell gör att de ofta är delaktiga i olika sjukdomsförlopp, allt från cancer till inflammation till ärrvävnadsbildning. Ökad förståelse för vad galektiner binder till, hur de binder samt vilka effekter det får i en cell är därför av stor betydelse för utveckling av framtida läkemedel.

Acknowledgements

During my years as a PhD-student I have come to meet a lot of wonderful people, from in-house to all over the world. Many have brightened the time at the lab by friendship and laughter, others my time away from the lab, all giving support and encouragement whenever needed. I would like to express my gratitude to all of you who have made my time so inspiring and joyful.

In particular, I would like to express my appreciation to:

Hakon Leffler, my supervisor, for being such a wonderful person. Your never-ending knowledge, curiosity and ingenious way of thinking are true sources of inspiration! Also a million thanks for the innumerable possibilities to ‘get out and around’; internationally (San Diego, Japan, and Brisbane) as well as nationally (GLIBS, taking courses, attending meetings, teaching, giving presentations etc.). Without you I had not been where I am today!

Past and present members of our group: **Barbro Kahl-Knutson**, **Inga Svensson-Danielsson**, **Yuning Qian**, **Emma Salomonsson**, **Ruth Hendus**, **Michael Carlsson**, and all the others passing through our lab. *Barbro and Inga* – for being the ‘pillars of the lab’ who cheerfully shared your knowledge: from how to make galectins to how to make cakes. *Yuning* – for being my friend and my teacher; always so encouraging. *Emma* – for fruitful and heartily discussions and sharing of office. *Ruth and Micke* – for enthusiasm and fun; and vital contributions in the generation of manuscripts.

The chemists: **Christopher Öberg**, **Johan Tejler**, **Ian Cumpstey**, and **Ulf Nilsson** for never giving up explaining the various ways you do your chemistry magic. *Christopher* – thanks for all your probes, delicious sushi and friendship; it has really made a difference!

Lotta Gustavsson, for introducing me to the world of confocal and for being such a heartily open person.

All the people at **MIG** who make the environment so inspiring and friendly!

My **folk dancing team**, and especially **Uffe** and **Ingrid Tholander**, for being so supportive and understanding, and for encouraging my leave as instructor while writing my thesis.

Anneli Edström, for all the walks, lunches, dinners and parties we have shared, talking about everything between heaven and earth. Okay, you are forgiven for not sticking around with Galectin-9 ;O)

My friends in the 'dinner group' and others: **Tina, Johan, Katti, Maria, Peter, Åsa, Andreas, Sidinh, John, Calle, Maja, Matilda, Anton** and **Marta**; with whom I have shared many relaxing dinners, talking both science and life. **Erika, Johan, Lotta, Edith, Stefan, Mia, Annette**, and **Jenny**. For being yourselves and for understanding my temporary silence.

My family, for your support even if you have not always understood what I have been doing.

Finally, I would like to thank **Pontus Nordenfelt**, my dearest, for believing in me when I didn't, and for always being there...

References

1. Lowe, J.B. and J.D. Marth, A genetic approach to Mammalian glycan function. *Annu Rev Biochem*, **72**: 643-91 (2003)
2. Ohtsubo, K. and J.D. Marth, Glycosylation in cellular mechanisms of health and disease. *Cell*, **126**: 855-67 (2006)
3. Varki A., C.R., Esko J., Freeze H., Hart G. and Marth J., *Essentials of Glycobiology*. 1999, New York: Cold Spring Harbour Laboratory Press. 1-653.
4. Torres, C.R. and G.W. Hart, Topography and polypeptide distribution of terminal N-acetylglucosamine residues on the surfaces of intact lymphocytes. Evidence for O-linked GlcNAc. *J Biol Chem*, **259**: 3308-17 (1984)
5. Wells, L. and G.W. Hart, O-GlcNAc turns twenty: functional implications for post-translational modification of nuclear and cytosolic proteins with a sugar. *FEBS Lett*, **546**: 154-8 (2003)
6. Feizi, T., Demonstration by monoclonal antibodies that carbohydrate structures of glycoproteins and glycolipids are onco-developmental antigens. *Nature*, **314**: 53-7 (1985)
7. Hernandez, J.D., et al., Galectin-1 binds different CD43 glycoforms to cluster CD43 and regulate T cell death. *J Immunol*, **177**: 5328-36 (2006)
8. Kornfeld, R. and S. Kornfeld, Assembly of asparagine-linked oligosaccharides. *Annu Rev Biochem*, **54**: 631-64 (1985)
9. Ruddock, L.W. and M. Molinari, N-glycan processing in ER quality control. *J Cell Sci*, **119**: 4373-80 (2006)
10. Ioffe, E. and P. Stanley, Mice lacking N-acetylglucosaminyltransferase I activity die at mid-gestation, revealing an essential role for complex or hybrid N-linked carbohydrates. *Proc Natl Acad Sci U S A*, **91**: 728-32 (1994)
11. Metzler, M., et al., Complex asparagine-linked oligosaccharides are required for morphogenic events during post-implantation development. *Embo J*, **13**: 2056-65 (1994)
12. Stanley, P., et al., Chinese hamster ovary cells selected for resistance to the cytotoxicity of phytohemagglutinin are deficient in a UDP-N-acetylglucosamine--glycoprotein N-acetylglucosaminyltransferase activity. *Proc Natl Acad Sci U S A*, **72**: 3323-7 (1975)
13. Freeze, H.H., Genetic defects in the human glycome. *Nat Rev Genet*, **7**: 537-51 (2006)
14. Marquardt, T. and J. Denecke, Congenital disorders of glycosylation: review of their molecular bases, clinical presentations and specific therapies. *Eur J Pediatr*, **162**: 359-79 (2003)
15. Vogt, G., et al., Gains of glycosylation comprise an unexpectedly large group of pathogenic mutations. *Nat Genet*, **37**: 692-700 (2005)
16. Hang, H.C. and C.R. Bertozzi, The chemistry and biology of mucin-type O-linked glycosylation. *Bioorg Med Chem*, **13**: 5021-34 (2005)
17. Lowe, J.B., Glycan-dependent leukocyte adhesion and recruitment in inflammation. *Curr Opin Cell Biol*, **15**: 531-8 (2003)
18. Lu, L. and P. Stanley, Roles of O-fucose glycans in notch signaling revealed by mutant mice. *Methods Enzymol*, **417**: 127-36 (2006)
19. Spiro, R.G., Protein glycosylation: nature, distribution, enzymatic formation, and disease implications of glycopeptide bonds. *Glycobiology*, **12**: 43R-56R (2002)
20. Endo, T., Structure, function and pathology of O-mannosyl glycans. *Glycoconj J*, **21**: 3-7 (2004)

21. Esko, J.D. and S.B. Selleck, Order out of chaos: assembly of ligand binding sites in heparan sulfate. *Annu Rev Biochem*, **71**: 435-71 (2002)
22. Duncan, G., C. McCormick, and F. Tufaro, The link between heparan sulfate and hereditary bone disease: finding a function for the EXT family of putative tumor suppressor proteins. *J Clin Invest*, **108**: 511-6 (2001)
23. Bollinger, C.R., V. Teichgraber, and E. Gulbins, Ceramide-enriched membrane domains. *Biochim Biophys Acta*, **1746**: 284-94 (2005)
24. Simpson, M.A., et al., Infantile-onset symptomatic epilepsy syndrome caused by a homozygous loss-of-function mutation of GM3 synthase. *Nat Genet*, **36**: 1225-9 (2004)
25. Prescher, J.A. and C.R. Bertozzi, Chemical technologies for probing glycans. *Cell*, **126**: 851-4 (2006)
26. Kikuchi, N. and H. Narimatsu, Bioinformatics for comprehensive finding and analysis of glycosyltransferases. *Biochim Biophys Acta*, **1760**: 578-83 (2006)
27. Raman, R., et al., Glycomics: an integrated systems approach to structure-function relationships of glycans. *Nat Methods*, **2**: 817-24 (2005)
28. Kilpatrick, D.C., Animal lectins: a historical introduction and overview. *Biochim Biophys Acta*, **1572**: 187-97 (2002)
29. Ackerman, S.J., et al., Molecular cloning and characterization of human eosinophil Charcot-Leyden crystal protein (lysophospholipase). Similarities to IgE binding proteins and the S-type animal lectin superfamily. *J Immunol*, **150**: 456-68 (1993)
30. Teichberg, V.I., et al., A beta-D-galactoside binding protein from electric organ tissue of *Electrophorus electricus*. *Proc Natl Acad Sci U S A*, **72**: 1383-7 (1975)
31. Drickamer, K., Two distinct classes of carbohydrate-recognition domains in animal lectins. *J Biol Chem*, **263**: 9557-60 (1988)
32. Barondes, S.H., et al., Galectins: a family of animal beta-galactoside-binding lectins. *Cell*, **76**: 597-8 (1994)
33. Lobsanov, Y.D., et al., X-ray crystal structure of the human dimeric S-Lac lectin, L-14-II, in complex with lactose at 2.9-Å resolution. *J Biol Chem*, **268**: 27034-8 (1993)
34. Cooper, D.N., Galectinomics: finding themes in complexity. *Biochim Biophys Acta*, **1572**: 209-31 (2002)
35. Houzelstein, D., et al., Phylogenetic analysis of the vertebrate galectin family. *Mol Biol Evol*, **21**: 1177-87 (2004)
36. Leffler, H., et al., Introduction to galectins. *Glycoconj J*, **19**: 433-40 (2004)
37. Swaminathan, G.J., et al., Selective recognition of mannose by the human eosinophil Charcot-Leyden crystal protein (galectin-10): a crystallographic study at 1.8 Å resolution. *Biochemistry*, **38**: 13837-43 (1999)
38. Hirabayashi, J., et al., Oligosaccharide specificity of galectins: a search by frontal affinity chromatography. *Biochim Biophys Acta*, **1572**: 232-54 (2002)
39. Lipkowitz, M.S., et al., Galectin 9 is the sugar-regulated urate transporter/channel UAT. *Glycoconj J*, **19**: 491-8 (2004)
40. Lipkowitz, M.S., et al., Functional reconstitution, membrane targeting, genomic structure, and chromosomal localization of a human urate transporter. *J Clin Invest*, **107**: 1103-15 (2001)
41. Nickel, W., Unconventional secretory routes: direct protein export across the plasma membrane of mammalian cells. *Traffic*, **6**: 607-14 (2005)
42. Hughes, R.C., Secretion of the galectin family of mammalian carbohydrate-binding proteins. *Biochim Biophys Acta*, **1473**: 172-85 (1999)
43. Seelenmeyer, C., et al., Cell surface counter receptors are essential components of the unconventional export machinery of galectin-1. *J Cell Biol*, **171**: 373-81 (2005)
44. Delacour, D., et al., Requirement for galectin-3 in apical protein sorting. *Curr Biol*, **16**: 408-14 (2006)

45. Brewer, F., Binding and cross-linking properties of galectins. *Biochim Biophys Acta*, **1572**: 255-62 (2002)
46. Rini, J.M. and Y.D. Lobsanov, New animal lectin structures. *Curr Opin Struct Biol*, **9**: 578-84 (1999)
47. Leonidas, D.D., et al., Structural basis for the recognition of carbohydrates by human galectin-7. *Biochemistry*, **37**: 13930-40 (1998)
48. Ahmad, N., et al., Galectin-3 precipitates as a pentamer with synthetic multivalent carbohydrates and forms heterogeneous cross-linked complexes. *J Biol Chem*, **279**: 10841-7 (2004)
49. Pace, K.E., et al., Restricted receptor segregation into membrane microdomains occurs on human T cells during apoptosis induced by galectin-1. *J Immunol*, **163**: 3801-11 (1999)
50. Nieminen, J., et al., Visualization of galectin-3 oligomerization on the surface of neutrophils and endothelial cells using fluorescence resonance energy transfer. *J Biol Chem*, **282**: 1374-83 (2007)
51. Demetriou, M., M. Granovsky, and S. Quaggin, Negative regulation of T-cell activation and autoimmunity by Mgat5 N-glycosylation. *Nature*, **409**: 733 (2001)
52. Partridge, E.A., et al., Regulation of cytokine receptors by Golgi N-glycan processing and endocytosis. *Science*, **306**: 120-4 (2004)
53. Miyanishi, N., et al., Carbohydrate-recognition domains of galectin-9 are involved in intermolecular interaction with galectin-9 itself and other members of the galectin family. *Glycobiology*, **17**: 423-32 (2007)
54. Hsu, D.K. and F.T. Liu, Regulation of cellular homeostasis by galectins. *Glycoconj J*, **19**: 507-15 (2004)
55. He, J. and L.G. Baum, Galectin interactions with extracellular matrix and effects on cellular function. *Methods Enzymol*, **417**: 247-56 (2006)
56. Zick, Y., et al., Role of galectin-8 as a modulator of cell adhesion and cell growth. *Glycoconj J*, **19**: 517-26 (2004)
57. Sato, S. and J. Nieminen, Seeing strangers or announcing "danger": galectin-3 in two models of innate immunity. *Glycoconj J*, **19**: 583-91 (2004)
58. Nakahara, S. and A. Raz, On the role of galectins in signal transduction. *Methods Enzymol*, **417**: 273-89 (2006)
59. Wang, J.L., et al., Nucleocytoplasmic lectins. *Biochim Biophys Acta*, **1673**: 75-93 (2004)
60. Hsu, D.K., R.Y. Yang, and F.T. Liu, Galectins in apoptosis. *Methods Enzymol*, **417**: 256-73 (2006)
61. Bianco, G.A., et al., Impact of protein-glycan interactions in the regulation of autoimmunity and chronic inflammation. *Autoimmun Rev*, **5**: 349-56 (2006)
62. Ilarregui, J.M., et al., The coming of age of galectins as immunomodulatory agents: impact of these carbohydrate binding proteins in T cell physiology and chronic inflammatory disorders. *Ann Rheum Dis*, **64 Suppl 4**: iv96-103 (2005)
63. Liu, F.T. and G.A. Rabinovich, Galectins as modulators of tumour progression. *Nat Rev Cancer*, **5**: 29-41 (2005)
64. Camby, I., et al., Galectin-1: a small protein with major functions. *Glycobiology*, **16**: 137R-157R (2006)
65. Dunic, J., S. Dabelic, and M. Flogel, Galectin-3: an open-ended story. *Biochim Biophys Acta*, **1760**: 616-35 (2006)
66. Poirier, F., Roles of galectins in vivo. *Biochem Soc Symp*, 95-103 (2002)
67. Thijssen, V.L., et al., Galectin-1 is essential in tumor angiogenesis and is a target for antiangiogenesis therapy. *Proc Natl Acad Sci U S A*, **103**: 15975-80 (2006)
68. Nishi, Y., et al., Role of galectin-3 in human pulmonary fibrosis. *Allergol Int*, **56**: 57-65 (2007)

69. Henderson, N.C., et al., Galectin-3 regulates myofibroblast activation and hepatic fibrosis. *Proc Natl Acad Sci U S A*, **103**: 5060-5 (2006)
70. Sakaguchi, M., et al., A carbohydrate-binding protein, Galectin-1, promotes proliferation of adult neural stem cells. *Proc Natl Acad Sci U S A*, **103**: 7112-7 (2006)
71. Sturm, A., et al., Human galectin-2: novel inducer of T cell apoptosis with distinct profile of caspase activation. *J Immunol*, **173**: 3825-37 (2004)
72. Tanaka, T. and K. Ozaki, Inflammation as a risk factor for myocardial infarction. *J Hum Genet*, **51**: 595-604 (2006)
73. Danielsen, E.M. and G.H. Hansen, Lipid raft organization and function in brush borders of epithelial cells. *Mol Membr Biol*, **23**: 71-9 (2006)
74. Delacour, D., et al., Galectin-4 and sulfatides in apical membrane trafficking in enterocyte-like cells. *J Cell Biol*, **169**: 491-501 (2005)
75. Huflejt, M.E. and H. Leffler, Galectin-4 in normal tissues and cancer. *Glycoconj J*, **20**: 247-55 (2004)
76. Toscano, M.A., et al., Dissecting the pathophysiologic role of endogenous lectins: Glycan-binding proteins with cytokine-like activity? *Cytokine Growth Factor Rev*, **18**: 57-71 (2007)
77. Lensch, M., et al., Unique sequence and expression profiles of rat galectins-5 and -9 as a result of species-specific gene divergence. *Int J Biochem Cell Biol*, **38**: 1741-58 (2006)
78. Markova, V., et al., Role of the carbohydrate recognition domains of mouse galectin-4 in oligosaccharide binding and epitope recognition and expression of galectin-4 and galectin-6 in mouse cells and tissues. *Int J Mol Med*, **18**: 65-76 (2006)
79. Saussez, S. and R. Kiss, Galectin-7. *Cell Mol Life Sci*, **63**: 686-97 (2006)
80. Nishi, N., et al., Galectin-8 modulates neutrophil function via interaction with integrin alphaM. *Glycobiology*, **13**: 755-63 (2003)
81. Hirashima, M., et al., Galectin-9 in physiological and pathological conditions. *Glycoconj J*, **19**: 593-600 (2004)
82. Ackerman, S.J., et al., Charcot-Leyden crystal protein (galectin-10) is not a dual function galectin with lysophospholipase activity but binds a lysophospholipase inhibitor in a novel structural fashion. *J Biol Chem*, **277**: 14859-68 (2002)
83. Ogden, A.T., et al., GRIFIN, a novel lens-specific protein related to the galectin family. *J Biol Chem*, **273**: 28889-96 (1998)
84. Hotta, K., et al., Galectin-12, an Adipose-expressed Galectin-like Molecule Possessing Apoptosis-inducing Activity. *J Biol Chem*, **276**: 34089-97 (2001)
85. Yang, R.Y., et al., Galectin-12 is required for adipogenic signaling and adipocyte differentiation. *J Biol Chem*, **279**: 29761-6 (2004)
86. Yang, R.Y., et al., Cell cycle regulation by galectin-12, a new member of the galectin superfamily. *J Biol Chem*, **276**: 20252-60 (2001)
87. Than, N.G., et al., Functional analyses of placental protein 13/galectin-13. *Eur J Biochem*, **271**: 1065-78 (2004)
88. Dunphy, J.L., et al., Isolation and characterization of a novel eosinophil-specific galectin released into the lungs in response to allergen challenge. *J Biol Chem*, **277**: 14916-24 (2002)
89. Gray, C.A., et al., Discovery and characterization of an epithelial-specific galectin in the endometrium that forms crystals in the trophectoderm. *Proc Natl Acad Sci U S A*, **101**: 7982-7 (2004)
90. Hadari, Y.R., et al., Galectin-8. A new rat lectin, related to galectin-4. *J Biol Chem*, **270**: 3447-53 (1995)
91. Gopalkrishnan, R.V., et al., Molecular characterization of prostate carcinoma tumor antigen-1, PCTA-1, a human galectin-8 related gene. *Oncogene*, **19**: 4405-16 (2000)

92. Su, Z.Z., et al., Surface-epitope masking and expression cloning identifies the human prostate carcinoma tumor antigen gene PCTA-1 a member of the galectin gene family. *Proc Natl Acad Sci U S A*, **93**: 7252-7 (1996)
93. Bassen, R., et al., Expression of Po66-CBP, a type-8 galectin, in different healthy, tumoral and peritumoral tissues. *Anticancer Res*, **19**: 5429-33 (1999)
94. Bidon, N., et al., Two messenger RNAs and five isoforms for Po66-CBP, a galectin-8 homolog in a human lung carcinoma cell line. *Gene*, **274**: 253-62 (2001)
95. Spitzenberger, F., J. Graessler, and H.E. Schroeder, Molecular and functional characterization of galectin 9 mRNA isoforms in porcine and human cells and tissues. *Biochimie*, **83**: 851-62 (2001)
96. Wada, J. and Y.S. Kanwar, Identification and characterization of galectin-9, a novel beta-galactoside-binding mammalian lectin. *J Biol Chem*, **272**: 6078-86 (1997)
97. Brichory, F., et al., Purification of a tumoral marker recognized by monoclonal antibody Po66 and associated with human lung squamous cell carcinoma. *Int J Biol Markers*, **11**: 148-52 (1996)
98. Hadari, Y.R., et al., Galectin-8 binding to integrins inhibits cell adhesion and induces apoptosis. *J Cell Sci*, **113 (Pt 13)**: 2385-97 (2000)
99. Nishi, N., et al., Galectin-8 and galectin-9 are novel substrates for thrombin. *Glycobiology*, **16**: 15C-20C (2006)
100. Nishi, N., et al., Development of highly stable galectins: truncation of the linker peptide confers protease-resistance on tandem-repeat type galectins. *FEBS Lett*, **579**: 2058-64 (2005)
101. Levy, Y., et al., Galectin-8 functions as a matricellular modulator of cell adhesion. *J Biol Chem*, **276**: 31285-95 (2001)
102. Matsushita, N., et al., Requirement of divalent galactoside-binding activity of ecalectin/galectin-9 for eosinophil chemoattraction. *J Biol Chem*, **275**: 8355-60 (2000)
103. Danguy, A., et al., Immunohistochemical profile of galectin-8 expression in benign and malignant tumors of epithelial, mesenchymatous and adipous origins, and of the nervous system. *Histol Histopathol*, **16**: 861-8 (2001)
104. Henno, S., et al., Expression of Po66-CBP, a galectin-8, in different types of primary and secondary broncho-pulmonary tumors. *Oncol Rep*, **9**: 177-80 (2002)
105. Nagy, N., et al., Galectin-8 expression decreases in cancer compared with normal and dysplastic human colon tissue and acts significantly on human colon cancer cell migration as a suppressor. *Gut*, **50**: 392-401 (2002)
106. Sheikholeslam-Zadeh, R., et al., The levels of expression of galectin-3, but not of galectin-1 and galectin-8, correlate with apoptosis in human cholesteatomas. *Laryngoscope*, **111**: 1042-7 (2001)
107. Simon, P., et al., The levels of retinoid RARbeta receptors correlate with galectin-1, -3 and -8 expression in human cholesteatomas. *Hear Res*, **156**: 1-9 (2001)
108. Bidon-Wagner, N. and J.P. Le Pennec, Human galectin-8 isoforms and cancer. *Glycoconj J*, **19**: 557-63 (2004)
109. Lahm, H., et al., Comprehensive galectin fingerprinting in a panel of 61 human tumor cell lines by RT-PCR and its implications for diagnostic and therapeutic procedures. *J Cancer Res Clin Oncol*, **127**: 375-86 (2001)
110. Lahm, H., et al., Tumor galectinology: insights into the complex network of a family of endogenous lectins. *Glycoconj J*, **20**: 227-38 (2004)
111. Bourguet, P., et al., Immunoscintigraphy of human lung squamous cell carcinoma using an iodine-131 labelled monoclonal antibody (Po66). *Br J Cancer*, **61**: 230-4 (1990)
112. Dazord, L., et al., A monoclonal antibody (Po66) directed against human lung squamous cell carcinoma immunolocalization of tumour xenografts in nude mice. *Cancer Immunol Immunother*, **24**: 263-8 (1987)

113. Dazord, L., et al., Uptake and release of radiolabelled monoclonal antibody Po66 by multicellular aggregates obtained from a lung squamous carcinoma cell line. *Anticancer Res*, **13**: 451-7 (1993)
114. Desrues, B., et al., Treatment of human lung carcinoma xenografts with a combination of 131I-labelled monoclonal antibody Po66 and doxorubicin. *Cancer Immunol Immunother*, **43**: 269-74 (1996)
115. Desrues, B., et al., Distribution of radiolabelled monoclonal antibody Po66 after intravenous injection into nude mice bearing human lung cancer grafts. *Cancer Immunol Immunother*, **30**: 295-9 (1989)
116. Desrues, B., et al., Monoclonal antibody Po66 uptake by human lung tumours implanted in nude mice: effect of co-administration with doxorubicin. *Br J Cancer*, **72**: 1076-82 (1995)
117. Desrues, B., et al., Biodistribution of monoclonal antibody Po66 in a human lung tumour-bearing mouse model: effect of blood exchange on tumour antibody uptake. *Nucl Med Biol*, **22**: 569-72 (1995)
118. Berthon, P., et al., Predisposing gene for early-onset prostate cancer, localized on chromosome 1q42.2-43. *Am J Hum Genet*, **62**: 1416-24 (1998)
119. Maier, C., et al., A candidate gene approach within the susceptibility region PCaP on 1q42.2-43 excludes deleterious mutations of the PCTA-1 gene to be responsible for hereditary prostate cancer. *Eur Urol*, **42**: 301-7 (2002)
120. Levy, Y., et al., Sustained induction of ERK, protein kinase B, and p70 S6 kinase regulates cell spreading and formation of F-actin microspikes upon ligation of integrins by galectin-8, a mammalian lectin. *J Biol Chem*, **278**: 14533-42 (2003)
121. Carcamo, C., et al., Galectin-8 binds specific beta1 integrins and induces polarized spreading highlighted by asymmetric lamellipodia in Jurkat T cells. *Exp Cell Res*, **312**: 374-86 (2006)
122. Arbel-Goren, R., et al., Cyclin-dependent kinase inhibitors and JNK act as molecular switches, regulating the choice between growth arrest and apoptosis induced by galectin-8. *J Biol Chem*, **280**: 19105-14 (2005)
123. Brewer, C.F., Thermodynamic binding studies of galectin-1, -3 and -7. *Glycoconj J*, **19**: 459-65 (2004)
124. Hirabayashi, J., Y. Arata, and K. Kasai, Reinforcement of frontal affinity chromatography for effective analysis of lectin-oligosaccharide interactions. *J Chromatogr A*, **890**: 261-71 (2000)
125. Oberg, C.T., et al., Efficient and expedient two-step pyranose-retaining fluorescein conjugation of complex reducing oligosaccharides: galectin oligosaccharide specificity studies in a fluorescence polarization assay. *Bioconjug Chem*, **14**: 1289-97 (2003)
126. Nakamura-Tsuruta, S., N. Uchiyama, and J. Hirabayashi, High-throughput analysis of lectin-oligosaccharide interactions by automated frontal affinity chromatography. *Methods Enzymol*, **415**: 311-25 (2006)
127. Ideo, H., et al., The N-terminal carbohydrate recognition domain of galectin-8 recognizes specific glycosphingolipids with high affinity. *Glycobiology*, **13**: 713-23 (2003)
128. Stowell, S.R., et al., Human galectin-1 recognition of poly-N-acetyllactosamine and chimeric polysaccharides. *Glycobiology*, **14**: 157-67 (2004)
129. Checovich, W.J., R.E. Bolger, and T. Burke, Fluorescence polarization--a new tool for cell and molecular biology. *Nature*, **375**: 254-6 (1995)
130. Sorme, P., et al., Fluorescence polarization as an analytical tool to evaluate galectin-ligand interactions. *Anal Biochem*, **334**: 36-47 (2004)
131. Lakowicz, J.R., *Principles of fluorescence spectroscopy*. Second edition ed. 1999, New York: Kluwer Academic / Plenum Publishers.

132. Collins, B.E. and J.C. Paulson, Cell surface biology mediated by low affinity multivalent protein-glycan interactions. *Curr Opin Chem Biol*, **8**: 617-25 (2004)
133. Paulson, J.C., O. Blixt, and B.E. Collins, Sweet spots in functional glycomics. *Nat Chem Biol*, **2**: 238-48 (2006)
134. Sears, C. and S.A. Armstrong, Microarrays to identify new therapeutic strategies for cancer. *Adv Cancer Res*, **96**: 51-74 (2007)
135. Blixt, O., et al., Printed covalent glycan array for ligand profiling of diverse glycan binding proteins. *Proc Natl Acad Sci U S A*, **101**: 17033-8 (2004)
136. Solomon, J.C., et al., Studies of the binding specificity of the soluble 14,000-dalton bovine heart muscle lectin using immobilised glycolipids and neoglycolipids. *Carbohydr Res*, **213**: 293-307 (1991)
137. Briles, E.B., et al., Vertebrate lectins, Comparison of properties of beta-galactoside-binding lectins from tissues of calf and chicken. *J Cell Biol*, **81**: 528-37 (1979)
138. Leffler, H. and S.H. Barondes, Specificity of binding of three soluble rat lung lectins to substituted and unsubstituted mammalian beta-galactosides. *J Biol Chem*, **261**: 10119-26 (1986)
139. Sparrow, C.P., H. Leffler, and S.H. Barondes, Multiple soluble beta-galactoside-binding lectins from human lung. *J Biol Chem*, **262**: 7383-90 (1987)
140. Rini, J.M., Lectin structure. *Annu Rev Biophys Biomol Struct*, **24**: 551-77 (1995)
141. Jencks, W.P., On the attribution and additivity of binding energies. *Proc Natl Acad Sci U S A*, **78**: 4046-4050 (1981)
142. Murray, C.W. and M.L. Verdonk, The consequences of translational and rotational entropy lost by small molecules on binding to proteins. *J Comput Aided Mol Des*, **16**: 741-53 (2002)
143. Mehta, P., R.D. Cummings, and R.P. McEver, Affinity and kinetic analysis of P-selectin binding to P-selectin glycoprotein ligand-1. *J Biol Chem*, **273**: 32506-13 (1998)
144. Somers, W.S., et al., Insights into the molecular basis of leukocyte tethering and rolling revealed by structures of P- and E-selectin bound to SLe(X) and PSGL-1. *Cell*, **103**: 467-79 (2000)
145. Lee, R.T. and Y.C. Lee, Affinity enhancement by multivalent lectin-carbohydrate interaction. *Glycoconj J*, **17**: 543-51 (2000)
146. Lee, Y.C., et al., Binding of synthetic oligosaccharides to the hepatic Gal/GalNAc lectin. Dependence on fine structural features. *J Biol Chem*, **258**: 199-202 (1983)
147. Kiessling, L.L., J.E. Gestwicki, and L.E. Strong, Synthetic multivalent ligands as probes of signal transduction. *Angew Chem Int Ed Engl*, **45**: 2348-68 (2006)
148. Mulvey, G.L., et al., Assessment in mice of the therapeutic potential of tailored, multivalent Shiga toxin carbohydrate ligands. *J Infect Dis*, **187**: 640-9 (2003)
149. Nishikawa, K., et al., A therapeutic agent with oriented carbohydrates for treatment of infections by Shiga toxin-producing Escherichia coli O157:H7. *Proc Natl Acad Sci U S A*, **99**: 7669-74 (2002)
150. Stanley, P., Glycosylation mutants of animal cells. *Annu Rev Genet*, **18**: 525-52 (1984)
151. Patnaik, S.K. and P. Stanley, Lectin-resistant CHO glycosylation mutants. *Methods Enzymol*, **416**: 159-82 (2006)
152. Martinez-Duncker, I., et al., Genetic complementation reveals a novel human congenital disorder of glycosylation of type II, due to inactivation of the Golgi CMP-sialic acid transporter. *Blood*, **105**: 2671-6 (2005)
153. Chen, J., D.J. Moloney, and P. Stanley, Fringe modulation of Jagged1-induced Notch signaling requires the action of beta 4galactosyltransferase-1. *Proc Natl Acad Sci U S A*, **98**: 13716-21 (2001)
154. Imperiali, M., et al., O Mannosylation of alpha-dystroglycan is essential for lymphocytic choriomeningitis virus receptor function. *J Virol*, **79**: 14297-308 (2005)

155. Lee, J., et al., Chinese hamster ovary (CHO) cells may express six beta 4-galactosyltransferases (beta 4GalTs). Consequences of the loss of functional beta 4GalT-1, beta 4GalT-6, or both in CHO glycosylation mutants. *J Biol Chem*, **276**: 13924-34 (2001)
156. Sasaki, H., et al., Carbohydrate structure of erythropoietin expressed in Chinese hamster ovary cells by a human erythropoietin cDNA. *J Biol Chem*, **262**: 12059-76 (1987)
157. Moloney, D.J., et al., Mammalian Notch1 is modified with two unusual forms of O-linked glycosylation found on epidermal growth factor-like modules. *J Biol Chem*, **275**: 9604-11 (2000)
158. Patnaik, S.K. and P. Stanley, Mouse large can modify complex N- and mucin O-glycans on alpha-dystroglycan to induce laminin binding. *J Biol Chem*, **280**: 20851-9 (2005)
159. Muhlenhoff, M., et al., Autocatalytic polysialylation of polysialyltransferase-1. *Embo J*, **15**: 6943-50 (1996)
160. Stanley, P., T. Sudo, and J.P. Carver, Differential involvement of cell surface sialic acid residues in wheat germ agglutinin binding to parental and wheat germ agglutinin-resistant Chinese hamster ovary cells. *J Cell Biol*, **85**: 60-9 (1980)
161. Warnock, D.E., et al., Determination of plasma membrane lipid mass and composition in cultured Chinese hamster ovary cells using high gradient magnetic affinity chromatography. *J Biol Chem*, **268**: 10145-53 (1993)
162. Esko, J.D., T.E. Stewart, and W.H. Taylor, Animal cell mutants defective in glycosaminoglycan biosynthesis. *Proc Natl Acad Sci U S A*, **82**: 3197-201 (1985)
163. Howard, D.R., et al., The GDP-fucose:N-acetylglucosaminide 3-alpha-L-fucosyltransferases of LEC11 and LEC12 Chinese hamster ovary mutants exhibit novel specificities for glycolipid substrates. *J Biol Chem*, **262**: 16830-7 (1987)
164. Campbell, C. and P. Stanley, A dominant mutation to ricin resistance in Chinese hamster ovary cells induces UDP-GlcNAc:glycopeptide beta-4-N-acetylglucosaminyltransferase III activity. *J Biol Chem*, **259**: 13370-8 (1984)
165. Brockhausen, I., F. Vavasseur, and X. Yang, Biosynthesis of mucin type O-glycans: lack of correlation between glycosyltransferase and sulfotransferase activities and CFTR expression. *Glycoconj J*, **18**: 685-97 (2001)
166. Conner, S.D. and S.L. Schmid, Regulated portals of entry into the cell. *Nature*, **422**: 37-44 (2003)
167. Norbury, C.C., Drinking a lot is good for dendritic cells. *Immunology*, **117**: 443-51 (2006)
168. Sigismund, S., et al., Clathrin-independent endocytosis of ubiquitinated cargos. *Proc Natl Acad Sci U S A*, **102**: 2760-5 (2005)
169. Di Guglielmo, G.M., et al., Distinct endocytic pathways regulate TGF-beta receptor signalling and turnover. *Nat Cell Biol*, **5**: 410-21 (2003)
170. Kirkham, M. and R.G. Parton, Clathrin-independent endocytosis: new insights into caveolae and non-caveolar lipid raft carriers. *Biochim Biophys Acta*, **1745**: 273-86 (2005)
171. Swanson, J.A. and C. Watts, Macropinocytosis. *Trends Cell Biol*, **5**: 424-8 (1995)
172. Grimmer, S., B. van Deurs, and K. Sandvig, Membrane ruffling and macropinocytosis in A431 cells require cholesterol. *J Cell Sci*, **115**: 2953-62 (2002)
173. Zhuang, Y., et al., Characterization of potent Na⁺/H⁺ exchange inhibitors from the amiloride series in A431 cells. *Biochemistry*, **23**: 4481-8 (1984)
174. Bonazzi, M., et al., CtBP3/BARS drives membrane fission in dynamin-independent transport pathways. *Nat Cell Biol*, **7**: 570-80 (2005)
175. Zhang, B. and A.C. Zehlf, Amphiphysins: raising the BAR for synaptic vesicle recycling and membrane dynamics. Bin-Amphiphysin-Rvsp. *Traffic*, **3**: 452-60 (2002)

176. Kaksonen, M., C.P. Toret, and D.G. Drubin, Harnessing actin dynamics for clathrin-mediated endocytosis. *Nat Rev Mol Cell Biol*, **7**: 404-14 (2006)
177. McNiven, M.A. and H.M. Thompson, Vesicle formation at the plasma membrane and trans-Golgi network: the same but different. *Science*, **313**: 1591-4 (2006)
178. Wang, L.H., K.G. Rothberg, and R.G. Anderson, Mis-assembly of clathrin lattices on endosomes reveals a regulatory switch for coated pit formation. *J Cell Biol*, **123**: 1107-17 (1993)
179. Simons, K. and G. van Meer, Lipid sorting in epithelial cells. *Biochemistry*, **27**: 6197-202 (1988)
180. Munro, S., Lipid rafts: elusive or illusive? *Cell*, **115**: 377-88 (2003)
181. Jacobson, K., O.G. Mouritsen, and R.G. Anderson, Lipid rafts: at a crossroad between cell biology and physics. *Nat Cell Biol*, **9**: 7-14 (2007)
182. Pike, L.J., Rafts defined: a report on the Keystone Symposium on Lipid Rafts and Cell Function. *J Lipid Res*, **47**: 1597-8 (2006)
183. Anderson, R.G. and K. Jacobson, A role for lipid shells in targeting proteins to caveolae, rafts, and other lipid domains. *Science*, **296**: 1821-5 (2002)
184. Mayor, S. and M. Rao, Rafts: scale-dependent, active lipid organization at the cell surface. *Traffic*, **5**: 231-40 (2004)
185. Kwik, J., et al., Membrane cholesterol, lateral mobility, and the phosphatidylinositol 4,5-bisphosphate-dependent organization of cell actin. *Proc Natl Acad Sci U S A*, **100**: 13964-9 (2003)
186. Nabi, I.R. and P.U. Le, Caveolae/raft-dependent endocytosis. *J Cell Biol*, **161**: 673-7 (2003)
187. Hommelgaard, A.M., et al., Caveolae: stable membrane domains with a potential for internalization. *Traffic*, **6**: 720-4 (2005)
188. Parton, R.G. and K. Simons, The multiple faces of caveolae. *Nat Rev Mol Cell Biol*, **8**: 185-94 (2007)
189. Kirkham, M., et al., Ultrastructural identification of uncoated caveolin-independent early endocytic vehicles. *J Cell Biol*, **168**: 465-76 (2005)
190. Le, P.U., et al., Caveolin-1 is a negative regulator of caveolae-mediated endocytosis to the endoplasmic reticulum. *J Biol Chem*, **277**: 3371-9 (2002)
191. Lamaze, C., et al., Interleukin 2 receptors and detergent-resistant membrane domains define a clathrin-independent endocytic pathway. *Mol Cell*, **7**: 661-71 (2001)
192. Sabharanjak, S., et al., GPI-anchored proteins are delivered to recycling endosomes via a distinct cdc42-regulated, clathrin-independent pinocytic pathway. *Dev Cell*, **2**: 411-23 (2002)
193. Vidricaire, G. and M.J. Tremblay, A Clathrin, Caveolae, and Dynamin-independent Endocytic Pathway Requiring Free Membrane Cholesterol Drives HIV-1 Internalization and Infection in Polarized Trophoblastic Cells. *J Mol Biol*, (2007)
194. Sauvonnnet, N., A. Dujeancourt, and A. Dautry-Varsat, Cortactin and dynamin are required for the clathrin-independent endocytosis of gammac cytokine receptor. *J Cell Biol*, **168**: 155-63 (2005)
195. Stillman, B.N., et al., Galectin-3 and galectin-1 bind distinct cell surface glycoprotein receptors to induce T cell death. *J Immunol*, **176**: 778-89 (2006)
196. Sato, M., et al., Functional analysis of the carbohydrate recognition domains and a linker peptide of galectin-9 as to eosinophil chemoattractant activity. *Glycobiology*, **12**: 191-7 (2002)
197. Ait Slimane, T., et al., Apical Secretion and Sialylation of Soluble Dipeptidyl Peptidase IV Are Two Related Events. *Experimental Cell Research*, **258**: 184 (2000)
198. Potter, B.A., et al., N-Glycans Mediate Apical Recycling of the Sialomucin Endolyn in Polarized MDCK Cells. *Traffic*, **7**: 146-154 (2006)