



LUND UNIVERSITY

The value of informing Children prior to examination and procedures

Edwinson Månsson, Marie

1992

[Link to publication](#)

Citation for published version (APA):

Edwinson Månsson, M. (1992). *The value of informing Children prior to examination and procedures*. [Doctoral Thesis (compilation), Department of Clinical Sciences, Lund]. Lund University: Faculty of Medicine.

Total number of authors:

1

General rights

Unless other specific re-use rights are stated the following general rights apply:

Copyright and moral rights for the publications made accessible in the public portal are retained by the authors and/or other copyright owners and it is a condition of accessing publications that users recognise and abide by the legal requirements associated with these rights.

- Users may download and print one copy of any publication from the public portal for the purpose of private study or research.
- You may not further distribute the material or use it for any profit-making activity or commercial gain
- You may freely distribute the URL identifying the publication in the public portal

Read more about Creative commons licenses: <https://creativecommons.org/licenses/>

Take down policy

If you believe that this document breaches copyright please contact us providing details, and we will remove access to the work immediately and investigate your claim.

LUND UNIVERSITY

PO Box 117
221 00 Lund
+46 46-222 00 00

The value of informing children prior to investigations and treatment

Akademisk avhandling som med vederbörligt tillstånd av Medicinska Fakulteten vid
Lunds Universitet för avläggande av doktorexamen i medicinsk vetenskap kommer att
offentligen försvaras i Bammedicinska kliniken föreläsningssal, Lasarettet, Lund, lördagen
den 16 maj 1992 kl. 09.15

av

Marie Edwinson Månsson
leg. barnsjuksköterska

Fakultetsopponent: DOC. Gisela Dahlqvist, Barnkliniken, Umeå

Lund 1992

Organization LUND UNIVERSITY Department of Pediatrics University Hospital S-221 85 Lund, Sweden	Document name DOCTORAL DISSERTATION	
	Date of issue May 16, 1992	
	CODEN: LUMEDW/MEBL--1019--SE	
Author(s) Marie Edwinson Månsson	Sponsoring organization	
Title and Nlbtile The value of informing children prior to investigations and procedures		
Abstract <p>The value of infoming children about impending medical procedures was investigated, particularly in ægard to possible effects on anxiety, fear, noncooperation and distress in specific clinical situations: urological investigation, heart catheterization, lumbar puncture, acute appendectomy. The use of a preparatory infonnation program was compared with conventional verbal infomation and pharmacological premedication. Pain, anxiety and noncooperative behaviour were measured using establish scales of subjective measurement and analyses of physiological measures: pulse, blood pressure and stress hormones. The preparation program consisted of a demonstration of the planned procedure to the child using, according to the child's age, a doll, play interaction, a photo album and/or verbal information. Parents were usually present. Ourstudies demonstrate the following findings: a preparation program reduced the number of anxious children needing premedication befor uroradiological examination; preparation compared favourably to pharmacological premedication; children with acute appendicitis indicated less anxiety after the preparation program and were comparable to controls who had received pharmacological premedication; children who had been prepared prior to heart catheterization also showed less anxiety prior to the procedure; at long tern follow-up, recollection of the hospitalization apparendy had been effected by the preparation program, possibly due to a more effective handling of anxiety and fear while still in hospital; perception of pain in a prepared group undergoing lumbar punctures showed anxiety reduction during repeated procedures.</p> <p>When the children's anxiety and noncooperation were rated by independent adults, including parents, a surprising degree of agreement was seen. Adults as a group, however, tended consistently to use low ratings for anxiety-noncooperation compared to tie child self rating of pain. Present findings are compared to those of other authors and are generally in agreement where similar questions have been posed. Further research and refinement ofmethods for the delivery ofpreparatory information to children facing painful or frightening medical procedures is, however, needed.</p>		
Key words Anxiety, appendectomy, children, cardiac catheterization, chemotherapy, fear, lumbar puncture, noncooperation, premedication, psychological preparation, pain, rating scales, stress homones, visual analo e scale.		
Classification system and/or index terms (if any)		
Supplementary bibliogaphical information		l*nguage English
ISSN and key tide		ISBN
Recipient's notes	Number of pages 144	Price
	Security classification	

Distribution by (name and address) Marie Edwinson Månsson, Department of Health Care Development, General Hospital, S-251 87 Helsingborg, Sweden

I, the undersigned, being the copyright owner of the abstract of the above-mentioned dissertation, hereby gant to an reference sources permission to publish and disseminate the abstract of the above-mentioned dissertation.

Date Mars 17, 1992

Marie Edwinson Månsson

Signature

The value of informing children prior to investigations and procedures

Marie Edwinson Månsson



Lund 1992

LUNEDW/MEBL --1019--SE

Transcription: Pia Lilja,
Department of Health Care Development,
General Hospital, Helsingborg

Bloms Boktryckeri AB, Lund 1992
ISBN 91-628-0572-X

With a smile he pushed the needle aggressively and deeply into the doll. "The doll does not feel anything, but we are people!",
(Boy, 6 years)

To Lennart and Edwina

This thesis is based on the following publications which will be referred to by their Roman numerals:

I Edwinston M, Lindahl S. Preparation of children for urinary X-rays and the use of premedication.

World Pediatrics and Child care 1986; 1:183-6.

II Edwinston M, Björkhem G, Lundström N-R. Värdet av utökad information till barn inför hjärkateterisering.

Läkartidningen 1985;82(41):3500-04.

III Edwinston M, Ambjörnsson E, Ekman R. Psychological preparation program for children undergoing acute appendectomy.

Pediatrics 1988;82:30-36.

IV Ambjörnsson E, Edwinston M, Naredi C, Sjöström S. Preoperativa psykologiska förberedelser av barn inför operation har betydelse även postoperativt.

Läkartidningen 1988;85(47):4072.

V Edwinston Månsson M, Fredrikzon B, Rosberg B. Psychological preparation compared to narcotic-sedative premedication in emergency surgery. Submitted for publication

VI Edwinston Månsson M, Björkhem G, Wiebe T. The effect of preparing children for lumbar puncture during chemotherapy treatment. Accepted for publication in Oncology Nursing Forum

(Articles reprinted with permission.)

CONTENTS

INTRODUCTION	1
AIMS OF THE INVESTIGATIONS	3
DEVELOPMENTAL CONCERNS	4
Infants	4
Toddlers	4
Preschoolers	4
School-age	5
Adolescents	6
REACTIONS TO HOSPITALIZATION	6
Fear	7
Anxiety	8
Noncooperation	9
Experience of pain	9
METHODS OF PREPARATION	10
Puppet show	11
Play therapy - handling equipment	11
Films and Slide shows	11
Other methods	12
VARIABLES AFFECTING PREPARATION	13
Age and developmental stage	13
Timing	13
Previous experience	14
Parental responses	14
Nursing care	15
Investigations on preparation methods	16

METHODS OF EVALUATION	17
PRESENT INVESTIGATIONS	21
Methods of preparation	21
Methods of evaluation	22
Methods of statistics	23
PREPARATION FOR RADIOLOGY (I)	24
PREPARATION FOR HEART CATHETERIZATION (II)	27
PREPARATION FOR ACUTE APPENDECTOMY (M)	31
FOLLOW-UP INTERVIEWS AFTER APPENDECTOMY (N)	34
PREPARATION VS PREMEDICATION (V)	36
PREPARATION FOR LUMBAR PUNCTURE (VI)	40
GENERAL DISCUSSION	46
Reducing anxiety	46
The need for premedication	47
Satisfaction with information	48
Age groups	49
Other findings	49
Difficulties with evaluations	50
Conclusion	51
SUMMARY	52
SWEDISH SUMMARY- SVENSK SAMMANFATTNING	55
ACKNOWLEDGEMENTS	60
REFERENCES	62
APPENDIX	

INTRODUCTION

During the past 40 years, a large amount of literature has confirmed that children and parents experience some degree of anxiety related to health care encounters, such as hospitalization and surgery. It is also generally recognized that many psychological maladjustments have their origin in childhood fears. Many of those fears are related to illness and medical procedures [9, 44, 57, 70, 781.

In recent years, several articles on the emotional meanings of illness to children at varying ages and levels of development have appeared in the literature [16, 30, 41, 50, 53, 71, 761. However, a child can tolerate discomfort if he is prepared for it, understands its real purpose and receives adequate support from understanding adults. Several different methods have been used to decrease the anxiety and stress that children experience when admitted to hospital. Parents may also need accurate information, since their emotional stability is necessary for the child's psychological well-being. Exploratory work on preparation was done in the United States by Beverly, as early as 1936 [8]. He suggested that anxiety could be reduced by a proper information to the child prior to medical procedures.

In 1968, play therapist Mrs. E. Plank, together with two colleagues, started the Association for the Care of Children in Hospital (ACCH). This is an organization in United States and Canada which monitors children's rights and seeks to foster and promote the health and well-being of children and families in health care settings, by means of education, planning for children in hospitals and research on children's well-being. The corresponding organization in the Nordic countries is called the Nordic association for the care of children in hospitals (NOBAB) and was started in 1979.

G. Klackenber, Swedish child psychiatrist, published a book in 1946 [40] where he discussed children's emotional trauma caused by hospitalization. Play therapy in hospitals in Sweden was started by Mrs Ivonny Lindquist M.D. Dr. hc, in Umeå in 1956. A special preparation program, to be used for children in hospital was **introduced** in Helsingborg by Mrs. Lindquist in 1979. Similar programs have gradually been introduced in other Swedish hospitals. This practice with preparation needs to be extended and a more

thorough understanding of the active psychological and behavioral processes worked out.

This thesis is a further development of the program for psychological preparation of children in hospital and an attempt to study the value of such programs.

AIMS OF THE INVESTIGATIONS

The aims of the present studies were to develop preparation programs for use before certain procedures (X-ray etc) and to evaluate the effect of such programs. The value of the preparation programs was investigated, particularly in regard to possible effects on children 's anxiety, fear, noncooperation and distress in clinical situations.

The separate aims of the various investigations were:

- * To investigate whether an improved preparation had reduced the need for premedication in children scheduled for urinary tract examinations (I).
- * To evaluate the effect of preparation on children prior to heart catheterization(II).
- * To determine whether preparation prior to an emergency operation would reduce anxiety (III); this also included a follow-up study, in the home, on children 's and parents' opinions of the hospitalization, using questions related to pain, fear and malaise (IV).
- * To investigate whether specific information prior to an emergency operation might reduce the need for premedication (V).
- * To determine whether information prior to lumbar puncture would reduce fear and anxiety (VI).

DEVELOPMENTAL CONCERNS

Preparation and support programs must be designed to meet the developmental needs of children. Since children have different concerns and cognitive abilities at each developmental stage, programs must be adapted to each child individually. The following is a list of the major concerns facing children from infancy through adolescence. The description of changes are based on Piaget's [51] stages of development.

Infants (0 to 12 months)

These children are concerned primarily with separation from their parents and immediate gratification. After 6 months of age, anxiety before strangers must be a factor in planning for their care.

Information for this age group should be given primarily to the parents. Photographs are useful while explaining the procedure to the parents.

Toddlers (1-3 years)

By this time the child performs mental associations by trial and error. The child is seeking independence and is looking for new skills in all areas of development (language, feeding, toileting etc.)

Programming for this age group should include both child and parent. The use of blanket and teddy bear is often valuable during stressful situations. Information about procedures is primarily given to the parents in this age group as well, but may also be given to the child if appropriate.

Preschoolers (3 to 6 years)

Between 3 and 6 years is the stage called "preoperational" or "preconceptual". Thought is intuitive, prelogical (magical). Here begin the first relatively unorganised and fumbling attempts to grasp the new and strange world of symbols. This age group is the most vulnerable to painful procedures. These children no longer feel totally supported and protected by their parents, and are most vulnerable to separation anxiety (21).

During the prelogical stage children tend to believe their senses rather than abstracting from experience or believing what is told to them. Prelogical children are likely to define pain in simple perceptual terms such as "pain is when it hurts" and often they will not make the link between pain and illness. Preschoolers are sensitive and fearful. It is important to establish good contact with the child and to be concrete.

The use of dolls is helpful with this age group. The primary fear among preschoolers is that of body mutilation. These children often perceive admission to the hospital as a punishment for some real or imagined

wrongdoing. Information is primarily given to the child, in the presence of the parents, using a photo-album together with a doll for demonstration of the procedure.

School-age child (6 to 12 years)

6 to 12 years is the stage of "concrete operational thought" and "concrete logical thinking". There are rational, well-organized adaptations. It is important for the child that physical appearances remain unchanged, in spite of the unavoidable effects of illness or treatment. Children in this stage understand the relationships between pain, other symptoms, and disease but without a clear understanding of the causation of pain. In many cases, they understand analogies such as "chemotherapy is like a poison that kills only the cancer".

The use of a doll, material to be used for the procedure and photographs are useful with this group. They also sometimes want to perform the procedure on the doll, since these children want to act out what the doctor has done to them.

Adolescents (12 to 18)

Twelve years and older is the stage of "formal operational thought". This group deals effectively with reality and also with propositional statements and the world of possibility. is adult type, although still egocentric at times.

Adolescents who have attained the level of formal logical explanations have a capacity to understand the complex interactions of physiological mechanisms in health and disease. They still show special concerns related to changes in physical appearance. Therefore, body-image concerns such as scars, the need to use or wear special appliances, can be threatening to this age group, as well.

These children are more likely to fear anesthesia than the surgical procedure itself. In this age group, fear of death and pain are verbalized as questions.

The use of photographs and peer support during preparation are extremely helpful to adolescents. The younger adolescents might also use the doll as a training model.

REACTIONS TO HOSPITALIZATION

Hospitalization means a change in life style for the child. The experience of other peoples nursing care in hospital may be upsetting to a young child. Blom in 1958 [9] concludes that the child's loss of ability to manage for himself such tasks as toilet, feeding and dressing returns him to the status of the small child. As a consequence, the child may become more infantile in his behavior or resist nursing care. Reactions to experience vary according to the age of the child [78], reason for hospitalization [44], length of time in hospital, and the preparation of the child for illness, hospitalization and separation [18].

Already in 1953, Prugh et al [57] found in their study on emotional reactions to hospitalization, that all children in their study showed some observable reaction to the experience of hospitalization and for illness, as distinct from the effect of the illness itself. These children were given a special program with visiting hours for parents, early ambulation, special play program, psychological preparation and integration of the parent's role. The program led to a significant decrease in the incidence and severity of reactions at all age levels.

The most common reactions to hospitalization are fear, anxiety and noncooperation. The experience of pain is also a common event during hospitalization on account of procedures, investigations and treatment.

Fear

Children at all ages experience fear, but in different ways, depending on their developmental stage. It is therefore important to study the emotional development of children in order to determine the conditions which stimulate fears and also to formulate an effective information program.

Research by Jessner et al 1952 [37] identified the types of preoperative fears of children aged 4 to 14. The focus of the anxiety was found to change, as one would expect, as the child matured. Information was collected from 144 children undergoing tonsillectomy and adenoidectomy. These children's fears were categorized into four groups:

*

fear of separation from parents and exposure to a strange environment (common at less than 5 years of age) * fear of needles (5-7 years of age) the operation seen as genital mutilation or punishment (5-9 years of age) the * anticipation of anesthesia seen as loss of control or death (10-14 years of age)

* Very similar findings were reported by Timmerman in 1983 and Broome in 1987 [75, 10].

"Fear of the unknown" is a phrase used by several authors. With limited ego development, the child often cannot comprehend the meaning and circumstances of his hospitalization and the various physical consequences of his illness. Many preparation programs are therefore aimed at "making the unknown known" and at helping the child to cope with a new situation [16, 67, 75].

Anxiety

While stress is certainly a part of all our lives [54] and mild stress is not necessarily hazardous to our mental or physical health, can be harmful if it exceeds moderate amounts. Anxiety is the subjective experience of the individual undergoing The level of anxiety experienced by the individual child has an effect on his ability to cope with When a child is hospitalized there is always a certain disü-ust for the hospital and parents are understandably anxious, and their anxiety does not go unnoticed by the child.

Jay [35] describes anxiety in children prior to highly painful medical procedures, bone-marrow aspirations and lumbar punctures, as demonsü•ated by behaviors such as nausea, vomiting, skin rashes, insomnia and crying, sometimes days before the procedures are scheduled to occur.

Faced with the anxiety of an unknown situation, such as illness and hospitalization, children tum to their parents for support [79]. It is therefore essential that the parents be allowed to stay with their child during the hospitalization. A preparation program designed to meet the child 's and the parents" needs can also be of geat help.

Noncooperation

Children between two and ten years of age reflect their fear, apprehension and anxiety in both behavioural and physiological reactions; this is the conclusion of several authors [10, 13, 14, 35, 38, 59, 74].

Jessner et al in 1952 [37] suggested that the child's disturbed ward behavior may be beneficial, since the child has thereby been able to express his anxiety. Visintainer and Wolfer [79, 83] express the view that preparation should decrease children's anxiety, thereby increasing their cooperation and decreasing their behavioral upset.

In studies on children's responses to different preparation programs, such measurements as ratings on cooperation are correlated with ratings on anxiety [13, 79, 83]. The higher the anxiety score, the greater is the amount of noncooperative behavior displayed.

Experience of pain

Many factors influence children's responses to painful procedures. Some factors, such as the hospital environment and prolonged illness or hospitalization, increase distress in children and parents. Other factors, such as parental presence during the procedure and opportunities for the child to participate actively in the procedure, can decrease the amount of distress.

It is clear that previously we have been ill-informed and misinformed about children's pain. Recent investigations have led not only to an increased understanding of pediatric pain, but also to an increase in our ability to appropriately measure and treat children's pain [1, 24, 46].

Children's cognitive development influences their experience of pain but their development does not always follow the discrete stages as outlined by Piaget (see page 4). Under stress a child's level of thinking may regress. Understanding of pain is a specific component of the child's knowledge of health and illness in general. The question of whether many or most children perceive pain, including pain produced by treatment, as punishment has not been resolved. The goal of pain management for pediatric procedures is to minimize suffering and permit a successful procedure [85].

METHODS OF PREPARATION

Several different methods have been used to decrease the anxiety and stress that children experience when admitted to hospital. Most methods of preparation emphasize the communication of information about upcoming events. Information is provided to the child because vague, undefined threats are more upsetting than threats that are known and understood. Unexpected stress is more upsetting than expected stress [6, 16, 26, 52, 78]. In the absence of accurate information, children of all ages often develop fantasies and distorted ideas.

Three major objects of preparation are identified in the literature and included in most preparation programs. These are:

- a) providing information to the child about the approaching event [4, 7, 48, 50, 78, 83]
- b) encouraging the child's expression of feelings and anxieties [4, 15, 50, 83]
- c) establishing confidence between the child and the hospital staff [50, 78, 79, 83, 86].

The manner of imparting the information should be simple, honest and reassuring and done at a level appropriate to the child's cognitive and psychological development. Preparation programs generally involve some or all of the following components:

- * giving the child information about what will be done *
- letting the child handle equipment
- * having the child practice the procedure on a doll introducing the child to medical personnel
- * discussion of fears, feelings, and questions on the child's part
- * helping the child to reconstruct the information given

Various methods have been used, including doll-play, hospital tours, storytelling, pamphlets and photo-albums. In most of the literature, parents are included, listening, when the preparation is given to the child.

Puppet show

By imparting information about the procedure, the puppet show helps the pre-school child (3-4 years) to understand a frightening situation [15, 48, 64].

The puppet show is usually •15 minutes long, shows a puppet hospitalized and includes admission routines, procedures and surgical sequences. Puppets incorporated into the performance (e.g. prior to surgery) include a doctor, anesthesiologist, nurse, mother and child. The play is designed to familiarize the child with hospital equipment, routines and personnel. After the show the child is encouraged to talk about it and to manipulate the puppets and equipment.

Play therapy - handling equipment

Play therapy is frequently used for children between 3 and 11 years [15, 18, 41, 48, 52, 74, 60, 64]. It is usually combined with the use of equipment involved in the procedure. During the therapy session the child and the therapist act out the procedure using either the real equipment or a miniature "mockup". During play, children are given the opportunity to act out, draw or describe events that they will experience in the hospital. Play also gives the child an opportunity to act out fantasies and anxieties and to express fear and anger caused by the hospital visit.

Films and Slide shows

There are various examples of films showing, on a screen, what is going to happen during the hospitalization in general. For example a puppet play show, "A Hospital visit with Clipper" is a film made at Children 's Hospital, Johnson 1974 Washington D.C., intended for children 3-8 years of age. The events illustrated in this puppet show are separation, waking up after an operation, painful injections and going home again. Another type of film shows a child being hospitalized, a filmed coping model, which refers to learning by imitation. The child in this film describes his feelings and concerns at each stage of the hospitalization. For example, "Ethan has an Operation" is a film

made by Melamed et al [47, 48], consisting of 16 scenes showing events that most children will encounter while hospitalized.

Slide shows are another type of preparation which can be used to illustrate details for older children and also allow time for questions during the show. Problems are discussed with the child during or after the show. Parents are usually present during the preparation.

Films showing more realistic situations have been extensively discussed, since not everyone agrees regarding this type of preparation. The main objections to this form of presentation are that the film moves too quickly and that the child has no opportunity to ask questions during the presentation. However, a film may be of value if the child is sufficiently mature and has been prepared for the film.

Photo-albums with pictures help the child to see what is going to happen in reality and also give the child an opportunity to understand that other children have gone through the procedure previously. An important requirement is that the photos be taken from the actual hospital, where the child is hospitalized, which renders the situation more realistic and familiar.

Other methods

Hypnosis, stress-inoculation and behavior therapy have been used in some studies to reduce discomfort and anxiety during painful medical procedures. A variety of relaxation techniques can be taught to the child and parent including distraction, deep rhythmic breathing, cutaneous stimulation, and positive self-talk. These techniques may be useful before, during and after the painful procedure.

In conclusion, younger children (ages 3 to 12) tend to benefit from programs utilizing play therapy, dolls and puppets, whereas older children, adolescents, will benefit more from verbal explanations, diagrams and audiovisual aids, such as films and slide shows.

VARIABLES AFFECTING PREPARATION

It is recognized that psychological preparation may not be equally effective for all children. Several variables that affect preparation have been reported in the literature, including age, developmental stage, timing of preparation, previous experience, anxiety level of the parents and type of nursing care.

Age and developmental stage

Age and stage of development are critical variables in predicting the type of preparation that will be most effective. As was described earlier, a cognitive development occurs in stages that qualitatively change across the span of childhood. However, it is important to keep in mind that some children will move more quickly to the next developmental stage than others. Therefore it is important that the information always be adapted to the individual child.

Timing

The efficacy of preparation also appears to be related to the time when it is given. A. Freud 1966 [28] suggested that if preparation begins too early it allows too much time for the child to fantasize and if it begins too late the ego does not have enough time to prepare defenses. Authors are not in agreement on the ideal time for preparation.

The uncertainty in the literature led to a study by Melamed et al 1976 [47] whose results demonstrated that older children (7 to 12 years) seem to benefit from preparation presented 1 week in advance of surgery, whereas younger children (4 to 7 years) need more immediate preparation, e.g. the night before surgery. Timmerman [75] describe how children 10-12 years react prior to and after surgery and is convinced that older school-age children need to express their feelings and concerns both before and after surgery.

Previous experience

Another variable to be considered when discussing preparation is the child's previous experience with health care. Children with previous experience are more aware of what can happen in the hospital and may, depending on age,

react inadequately to a new hospitalization. Kellerman et al [39] found that anxiety and discomfort do not automatically diminish with repeated procedures. Their data support the observations of others that anticipatory anxiety may develop and increase over time [38, 85]. Therefore a preparation program is even more important to those children, especially if the last hospital experience was unpleasant for the child.

Parental responses

Family factors include parental attitudes and presence or absence of parents during the procedure. Highly anxious parents can transmit their emotional state to the child. This transmission of anxiety intensifies the child's own fear and anxiety about a painful procedure. Research shows that if the parents, particularly the mother, are provided with information and emotional support, their own level of stress may be reduced [13, 19, 20, 32, 79, 80]. This in turn allows parents to make a more efficient adaptation to the child's problems and to take a more active role in helping the child to cope.

Consequently, the child experiences less stress and develops a more positive response to hospitalization and surgery [44, 58, 79]. Because of the importance of the parent-child relationship, parents must also participate in the preparation. They, too, need accurate information and appropriate reassurance. They also need to know what they can do to help care for their child's physical and emotional needs and how important their emotional stability is for the child's psychological well-being.

Nursing care

The nurse participates in all aspects of patient care on the unit. The nurse is therefore an important person to the child and influences his experiences.

Misconceptions about pain, e.g. that children do not experience pain as intensely as adults, have been common and may have negatively influenced the nurses' interaction with children. Measures to reduce anxiety, such as preparation for a procedure, may be seen as unnecessary [23, 43].

Health care professionals have found it easier in the past to pain behavior in children to emotions such as fear, anxiety, separation, anger and sadness [1]. However, it has been clearly shown that children experience pain and that the signaling of pain by body movements, as well as by verbal and facial expressions are important indicators of emotional responses to pain. The diffuse body response to pain in infants decreases noticeably by the end of the first month [43]. Fear of pain begins to appear at around 6 months of age. Between 3 and 10 months of age infants are able to localize pain and will react to a painful stimulus by withdrawing the affected [56].

In a study by Elander et. al [24], on pain relief in children, they found that attitudes to pain relief were not uniform. Postoperative pain relief is given but dosage and intervals between doses are In another study by Eland, in 1981 [22], postoperative pain relief was studied in 18 children (5-8 years old) and 18 matching adults with similar operative diagnoses. He found dramatic differences in the use of analgetics. All 18 adults received more post-operative analgesic than the children.

Visintainer and Wolfer [79.] studied the efficacy of nursing care provided by a single nurse who was present at critical times. This "stresspoint" supportive care was intended to remove or minimize sources of stress and assist the child in coping with unavoidable stress through the provision of information, instruction and support. They found that the children who had received nursing care by the stress-point nurse, experienced less hospital upset, and fewer posthospital adjustment problems. Parents of children in this group had lower self-ratings of anxiety and expressed greater satisfaction with care than parents in a control group.

In a study by Wolfe et al [84] forty-two pediatric oncology nurses were surveyed regarding stress-reduction techniques for children undergoing bonemarrow aspirations and lumbar punctures. Nurses considered themselves knowledgeable and capable in several stress-reduction techniques that can be employed during the procedure itself (e.g., deep breathing and distraction). However, they considered themselves less knowledgeable and capable with advanced preparation techniques such as play therapy and hypnosis.

Investigations on preparation methods

The prevalence and nature of psychological preparation for pediatric care, in Children 's Hospitals and acute care at General Hospitals in the United States have been investigated by Azamoff and Woody [4]. They received answers from 1427 hospitals and found that the most used methods were: visits prior to hospitalization, group tours and group discussions. During hospitalization, children learned informally as events occurred, usually through conversation.

The use of play is often investigated in combination with other methods [49, 79, 83]. This makes it difficult to evaluate the effectiveness of play therapy alone as a means of reducing stress.

METHODS OF EVALUATION

Several different methods have been presented in the literature on how to evaluate the effect of preparation in terms of how children 's behavior, their reactions to hospitalization and procedures, have been influenced. The evaluation methods can be divided into subjective and objective measurements.

The subjective measurements are usually ratings done by the parents and/or the nurse observer and/or by the child himself. The most commonly used rating scales can be categorized as point scales, analogue scales (Visual Analogue Scale, VAS), and other rating scales and questionnaires.

The point scales usually have a rating from 1 (little or no reaction) to 3, 5 or 6 (extreme emotional distress). These scales are usually used for ratings of anxiety or behavioral reactions [48, 77, 79]. The ratings are usually performed by nurses and/or parents.

Venham has developed two rating scales, "the interval rating scale", one anxiety scale and one noncooperation scale. Each is a six-point scale, with scale points anchored in objective, specific and readily-observable behavior. These scales were developed to assess children 's response to dental stress.

Visintainer [79] used similar scales, for example "The Satisfaction Questionnaire", which included parental evaluations regarding 20 aspects of their child 's medical and nursing care. The rating was made on a 4-point scale with 1 indicating great dissatisfaction and 4 great satisfaction. "The Hospital

Fears rating scale" used by Melamed [48] is a fear rating scale for children, that ranges from 1 (not afraid at all) to 5 (very afraid). The sum of the ratings for 16 items formed the subject's score for this measure.

The analogue scale is a continuous scale on which exact fractional positions can be indicated, as on a ruler or thermometer. The "Visual Analogue Scale" (VAS) is such a scale. This scale consists of a 10 centimeter

2

plain line where the extreme left represents no pain at all, 0 cm, while the extreme right represents very much pain, 10 cm. The degree of feeling may be indicated as a position on the line that best reflects the observer's judgement. This is then measured by reading from a numerical scale on the opposite side of the "thermometer". Clarke and Spear [17] presented this method in 1964, and an attempt was made to assess the sensitivity and reliability of this of self-rating when used at frequent intervals. The method has been used in studies with children, mostly for the measurement of pain [1, 29, 31, 33, 66, 68], or to measure functional capacity in patients with rheumatoid arthritis (66). Because pain is essentially a subjective experience, assessment of children 's pain must emphasize the child's perception of the experience.

Other rating scales have taken the form of list of words and behavioral observation scales showing levels of discomfort.

The "Anxiety scale" was developed by Melamed [48] with lists of words, which the mother rates as "true" or "false" about her child, and is intended to measure chronic anxiety. This scale has been used in many studies [63, 64, 65, 74, 80].

The "Observers Rating Scale of Anxiety" was also developed by Melamed [48] as a behavioral observation scale using 29 categories of verbal and noncooperation items thought to represent behavioral manifestations of anxiety in children. Examples of items indicating anxiety included "crying, trembling hands, stutters" and "talks about hospital fears, separation from mother, or going home".

Picture series showing increasing levels of discomfort are instruments where the child identifies varying intensities of pain; some such devices include line drawings of faces or a photographic scale of facial expressions [46]. Research has shown, that children are able to indicate the varying levels of pain if an adult can provide an appropriate device for doing this [1, 46]. At this point in time, self-reports are the best available indicators of the child's subjective experience.

Questionnaire may be given to parents for evaluation of their own level of anxiety, their child's medical and nursing care, or the adequacy of information they have received. "The Information Questionnaire" asks parents to evaluate the adequacy of the information they received [79]. "Post-hospital adjustment" [78] is a parental questionnaire which consists of 27 behavioral items comprising those most frequently cited in the literature as occurring in children following hospitalization.

The subjective methods are, thus, either questionnaires or rating scales indicating anxiety, cooperation or other variables associated with anxiety/fear.

Objective methods include: pulse, blood-pressure, recovery room medication requirements, ease of fluid intake and time to first voiding after surgery [79].

The Palmar Sweat Index (PSI) is used as a physiological measure of anxiety. The relationship between sweating and stress is well documented in the literature by Melamed [48] and Schultz [64], who demonstrated that palmar prints obtained by the PSI procedure were significantly related to stress and anxiety.

Measurements of ACTH, cortisol and catecholamines have been used to evaluate Sigurdsson [69] found that plasma concentrations of ACTH and cortisol increased similarly during adenoectomy when using halothane anaesthesia. Rectal premedication with diazepam, morphine and hyoscine significantly decreased plasma ACTH and cortisol response to surgery during halothane anaesthesia. In a study by Lundberg [42] the cortisol and catecholamines excretion in urine in children was studied in a day-care setting as compared to home. His results showed that adrenaline excretion at the daycare center was significantly higher than at home in both boys ($p < 0.05$)

and girls ($p < 0.05$), while there were no corresponding differences in noradrenaline excretion. Cortisol excretion did not differ significantly between sexes or conditions. Lundberg suggested that mental rather than physical arousal was higher at the day-care center than in the at-home condition and that mental arousal was induced by e.g. social interaction with other children, emotional involvement in the games and activities organized at the center. The relationship of plasma cortisol and β -endorphin to surgical stress and postoperative analgesic requirement was investigated by Pickar et al. [52]. They hypothesized that the endogenous opioids (endorphin) system is related to biological stress responses. Patients (adults) who had lower presurgical or surgically stimulated levels of plasma β -endorphin and/or cortisol were those who required greater amounts of postoperative analgesics.

It is difficult, however, to use hormones as indicators of stress in children, due to the difficulty in defining reference levels for children according to sex and age, particularly where the further complication of diurnal rhythms must be considered.

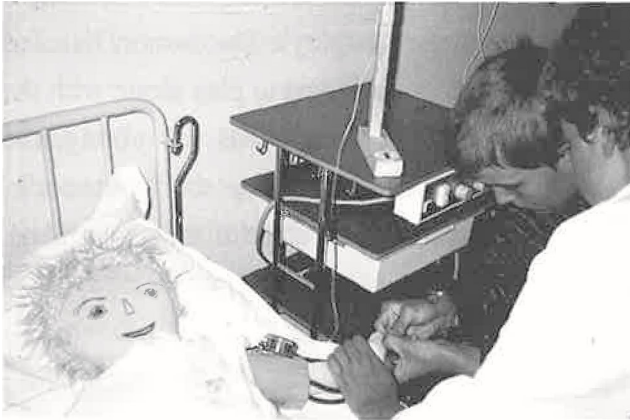

PRESENT INVESTIGATIONS

Method of preparation

* Demonstration of the entire procedure on a doll was done in studies I, II, III, V and VI. For study VI (lumbar puncture) a special doll was constructed with a wooden spine. Special materials suitable for each demons procedure were used on the doll.

* An album describing the procedure by means of photographs of a child who had previously undergone the procedure was used in studies I, II, III, V and VI. The illustrations cover events from beginning to end of the procedure. What was to be done during the operation was not described (III, V).

* A pamphlet with information about the investigation was sent to the patient's home prior to scheduled admissions in studies I and II; this was meant to help the parents to begin preparing the child at home, prior to the scheduled admission to hospital.

* A visit to the X-ray department prior to the examination was included the day before the procedure in study I.

The child's understanding of the procedure was checked during play by the program nurse, and any misconceptions were corrected. This was done in all studies except in study IV (follow-up after surgery). The parents listened

while the child was prepared and the child was allowed to play alone with the materials after the preparation session. If the child was too young, the information was given directly to the parents, using the photobook. Adolescents were informed using the photo-album, alone if they so wished, or together with their parents.

Methods of evaluation

Several methods were used to evaluate the effect of the preparadon program .

Subjective methods:

- 1 . Interviews were conducted with parents concerning their own anxiety and about their and the children 's knowledge of the procedure (II), while in study IV both parents and children were inteviewed about recollectiöns of the children 's pain, fear and malaise.
2. Ward observations of the children 's behaviour and anxiety done by u•ained observers (II).
3. Ratings using Visual Analogue Scale (VAS) were done by parents and nurses to record the children's säess (IH), and fear (V).
4. Ratings using an anxiety and a noncooperation scale (6-point scales) were done by parents, nurses and two observers watching a video-uptake of the lumbar punctures in study VI.
5. Self ratings on VAS were done by children and parents, concerning their fear (V). In study VI the children rated their experience of pain on a VAS scale.

Objective methods:

- 1 . Physical: pulse, blood-pressure (III,V).
- 2 Stress hormones: cortisol (III,V), β -endorphins, noradrenaline, adrenaline, ACTH (111).
3. Premedication: changes in the amount used (I).

Statistical methods

In each of the six studies we used traditional instruments of measurement, subjective and objective, as indicators of stress and anxiety in our patients. However, some findings are descriptive and cannot be easily quantified.

Conventional tests for statistical significance have been applied, using whenever possible one "method of choice" together with at least one corroborating, though less favored, method. Associated probabilities (p values) have been presented in context.

In our choice of descriptive data, we have relied primarily upon conventional frequency tables, percent distributions and mean \pm 1 standard deviation (the most familiar measures of central tendency). We should perhaps note that the median has generally been avoided in these studies, due to its unpredictable behavior in small samples.

The Spearman rank coefficient of correlation was used to evaluate the degree of association between VAS scores as recorded by the various observer categories (III,V). After correction for tied values, this coefficient was considered to provide a more conservative measure of association, compared to its parametric counterpart.

Probabilities associated with observed differences between groups have been estimated using established tests for significance. These are listed below: Parametric tests: Student's T-test for difference between means (III), twotailed paired T-test (m, v,VI).

Nonparametric tests: Mann-Whitney U-test (III,V, VI), Wilcoxon's signed rank test (V), Chi-square test (1,11,VI), Speannan rank correlation coefficient (III, VI), Fisher's "exact probability" test with Tocher's modification (IV), and Binomial test (III, V).

PREPARATION FOR RADIOLOGY (1)

In 1980 a preparation program for children scheduled for urinary tract examinations was started. During the years before that, a more liberal use of premedication in these children had been noted. In this retrospective study we

wanted to investigate whether the improved preparation of children and parents had reduced the incidence of sedative premedication in children scheduled for urinary tract radiology.

Material

During a 5-year period (1978-1982), covering 2.5 years without, and 2.5 years with a preparation program, 389 children scheduled for intravenous pyelogram and cystography with voiding were investigated. Their median age was 6 years (range 2 to 17 years). The patients were divided into two groups. Group I (control) examined from January 1978 to June 1980, included 160 children who had received only verbal information by the physician.

Group II (prepared) were examined from July 1980 to December 1982 and consisted of 229 children who received the preparation program as well as verbal information.

Premedication

The need for premedication was usually decided by the staff nurse and the physician on duty. Premedication was generally prescribed only to those children who showed fear and anxiety prior to the procedure. Such children received either diazepam (about 0.25 mg/kg rectally) or a pethidine compound (up to 0.1 ml/kg intramuscularly).

Method

The preparation program consisted of a demonstration of the procedure on a doll, a photo-album, a visit to the X-ray department and a pamphlet sent to the home, as described above. Children in the control group were verbally informed. To evaluate the effect of the preparation program, case sheets were studied retrospectively for each child, noting the use of premedication.

Results

The number of investigations increased during the last three years of the study. During the first half, 160 children were investigated compared to 229 during

the second half. This increase was due to revised indications for urogenital examination in children.

Sex distribution and age ranges, however, were similar throughout the study. The incidence of sedative premedication was 33.1% during the first period and 20.5% ($p < 0.001$) during the second period, after the preparation program had been started (Fig. 1). Most of the children receiving



Fig. 1. The incidence of premedication wed each year. The dotted line divides the material in the 25 years prior to and in the 25 years after the start of pre-examination preparation. 1980 AZ Incidence of premedications from January to June 1980. 1980 B = Incidence of premedications from July to December 1980.

Discussion

In this retrospective study, all children scheduled for urinary X-rays during the study period were included. The more frequent use of sedative premedication during the first period was thought afterwards to be due to the lack of a good preparation program.

Fig. 1 shows that although the incidence of premedication decreased during the second period, its use was still high at the beginning of the second period but decreased considerably thereafter. This illustrates how the

introduction of a new routine may require at least a 3-month period of adjustment. Later, the number of children needing premedication was markedly reduced and the preparation program was seen as beneficial.

It was concluded that for children undergoing urogenital investigation, an improved preparation program reduced the signs of fear and anxiety, thereby reducing the need for pharmaceutical premedication.

PREPARATION FOR I-HEART CATHETERIZATION (11)

The objective of this study was to develop and evaluate a preparation program to be given to children scheduled for heart catheterization. We also wanted to evaluate whether such information gave the child a better opportunity to handle the situation, improved his ability to cooperate, or contributed to a greater sense of security.

Material

The study consisted of 48 children admitted to hospital for heart catheterization. Their median age was nine years (range 2 to 19 years). Twentyfive children had undergone cardiac surgery, sixteen as infants and nine later. Four children had been reoperated several times. Fifteen children were having their first heart-catheterization and of these were three under four years of age. Thirtythree children had been heart-catheterized several times before and fifteen of these had been younger than four years of age at the time of previous catheterizations.

The children were divided into two groups:

- * a control group with 24 children receiving verbal information, and an
- * experimental group with 24 children, who received both verbal information and the preparation program, along with their parents. The preparation program used in this study consisted of demonstration on a doll, using the photo-album and a pamphlet which was sent to the home prior to the admission to hospital.

Premedication

At the day of examination children received premedication either in the form of the "Toronto cocktail" given intramuscularly (up to 0.1 ml/kg of bodyweight) or morphine (0.15 mg/kg body weight subcutaneously) and Diazepam (0.5-1.0 mg/kg body weight rectally or orally). 1 ml of the "Toronto cocktail" contains 25 mg pethidine, 6.25 mg chlorpromazine and 6.25 mg promethazine. When morphine was given the maximum dose was 5 mg.

Interviews

To study the value of the preparation program parents were interviewed two times: first in the hospital, before the catheterization, and then again by telephone a month later. The questions at the hospital centered on parents' and children's knowledge about what would happen during the procedure, whether the information had been sufficient, and about the parent's own anxiety prior to the investigation. A month later the questions centered on the information given about the procedure, if the child had an adequate recollection of the catheterization and whether the parents had seen any changes in the child's behavior after hospitalization.

The child's behavior

A nurse, who had not taken part in the preparation of the child, rated the child's behavior in the ward on the day of catheterization and at four later occasions: when premedication was given, when the parents left the child at the X-ray department, when the local anesthetic was injected and when X-ray contrast was administered.

The nurse noted if the child was calm, anxious (unhappy appearance) or frightened (constant or frequent crying).

Results

Statistically significant differences were found between the groups regarding satisfaction with information. As can be seen in Fig. 2, twentythree parents in the prepared group were satisfied, compared to 14 in the control group ($p < 0.01$).

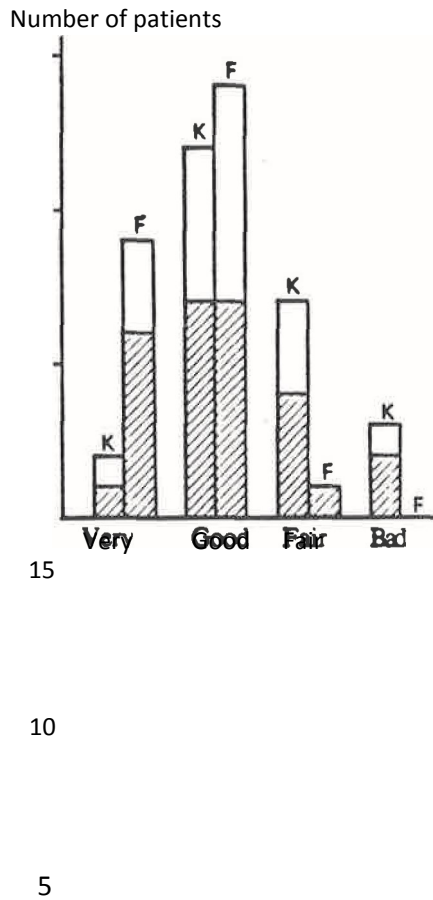

Fig. 2. Parents ' opinions regarding information given. C = control grozpz, P = prepared group.

There was also a **statistically** significant difference between the groups regarding children's behavior at the ward prior to the investigation with children in the prepared group showing less anxiety 0.025), Fig. 3.

Children who received the preparation program also showed significantly less anxiety during the procedure, especially when receiving local anaesthesia, compared to the control group (p < 0.01).

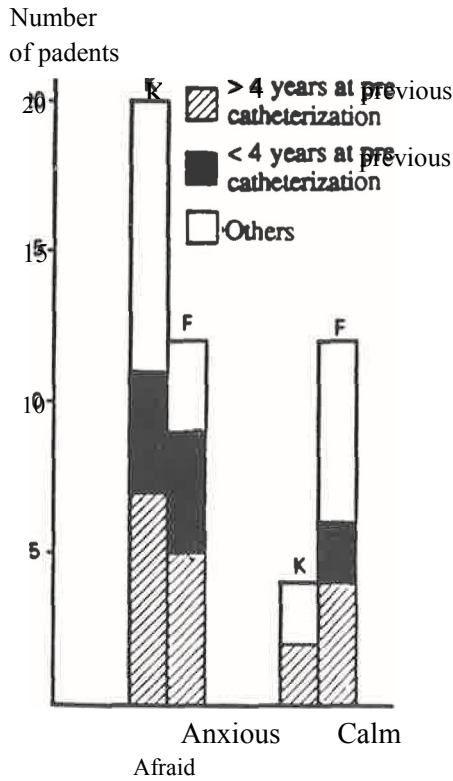

Fig. 3. Children's behavior prior to catheterization. C = control group, P = prepared group

On follow-up interviews by telephone, the prepared group was more satisfied with the information as given ($p < 0.01$). Changes in the children's behavior such as anxiety, greater dependence on parents and sleeping disturbances were more frequent in the prepared group. These changes were, however, not statistically significant and such symptoms had disappeared by the time of the follow-up interview.

Discussion

It was concluded that a preparation program can help the child to cope better with a heart catheterization. The traditional information given prior to the start

of this program was sufficient in many cases, while in other cases there was a clear need for more and better information.

The traditional information to the prepared group was evaluated as "very good" or "good" by half of the control group, while the other half asked for more information. Since parents in the prepared group had already received the information pamphlet prior to admission, they reported that it had been possible to reduce the child's anxiety and to better prepare both the child and themselves at home. They also felt that it was easier to ask questions about the procedure during admission. The interviews in study II were done by the same nurse who also had informed the child and may therefore be suspected of bias. However, the ratings on children prior to and during catheterization were done independently by trained nurses.

Parents in the prepared group were more confident of how their children would tolerate the procedure, although this difference was not statistically significant. These parents may have formed their opinions while observing the child's behaviour during preparation and were feeling more relaxed after the preparation session together with their child.

PREPARATION FOR ACUTE APPENDECTOMY (M)

The purpose of this study was to determine whether information prior to an acute operation would reduce anxiety.

Methods

24 children, admitted to the hospital consecutively and operated on for appendicitis, were included. At admission, the child was assigned to a control group (1) or a prepared group (2). The latter group received a preparation program which included a photo-album, and a demonstration of material to be used for the procedure. What was to be done during the operation was not described.

The nurse in charge registered the stress of child and parent using a Visual Analogue Scale (VAS). This was done 1) in the emergency unit (both groups unprepared), 2) at the admissions unit (after preparation in group 2 and

prior to sedative premedication, in both groups), 3) on admission to the operating unit, and 4) before induction of anaesthesia. The nurse also recorded the child's pulse rate and blood-pressure at clinical units 1, 2 and 4. The nurse in emergency unit, operating unit and before induction were not aware about the purpose of the study. Blood samples for stress hormones (cortisol, ACTH, and β -endorphin) were drawn at clinical units 1, 2 and 4. Blood samples for catecholamines (noradrenaline and adrenaline) were drawn only in clinical units 2 and 4, because of the possible effect of needle insertion at the first unit.

Results

The mean values and standard deviations of the VAS ratings are given in Table 1.

Visual Analogue Scale in Four Units

Group	Emergency	Admission Unit	Operating Unit	Induction of Anesthesia
<hr/>				
(Unit Children				
1	2.8 ± 3.3	3.9 ± 2.6 ^b	0.8 ± 0.7	0.7 ± 0.8
2	7.7 ± 2.5 ^a	0.7 ± 0.5 ^b	0.2 ± 0.1	0.2 ± 0.1
<hr/>				
Parents				
1	1.0 ± 2.1 ^a	2.9 ± 2.3 ^c	0.8 ± 1.2	
2	4.7 ± 2.5 ^a	0.5 ± 0.3	0.2 ± 0.2	

Table 1. Results are mean ratings on the scale ± SD. Group 2 children (n=12) were psychologically prepared preoperatively; group 1 children (n= 12) were not. Statistical significance determined by two-tailed paired t-test: ^a P < .001, emergency unit v admission unit; ^b P < .01, admission unit v operating unit; ^c P < 0.5, admission unit v operating unit.

Children's reaction

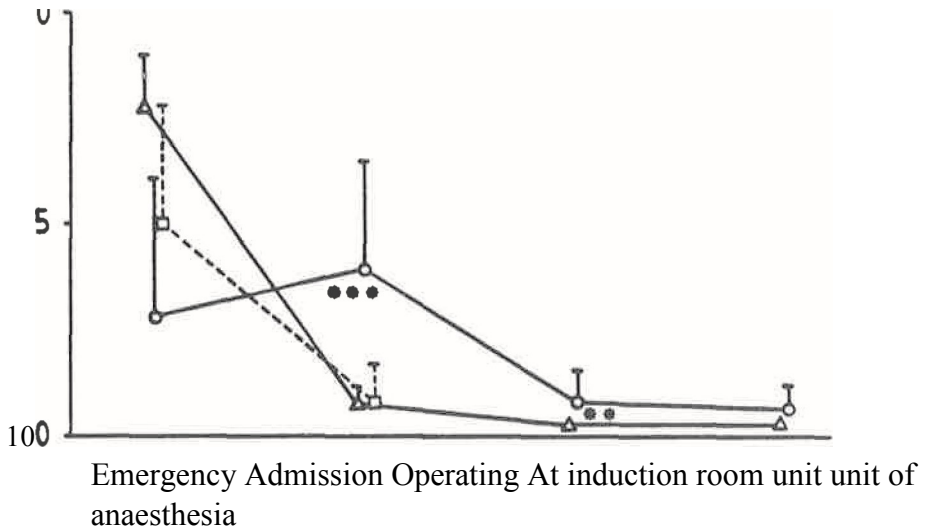

Fig. 4. Children's reactions on Verbal Analogue Scale at four stages prior to surgery. Results are means \pm SD determined by Mann-Whitney U test A, Children psychologically prepared; O children not prepared.

In Fig. 4 and Table 1 it can be seen that at the emergency unit, children in the prepared group (gr 2), were generally more frightened than children in the control group (0.01), while at the admission unit, where group 2 had been prepared, their states were reversed ($p < 0.01$). At the operating unit, where both groups had received premedication, group 1 children were still significantly more afraid than those in group 2, with the prepared group less afraid than the unprepared group (0.05).

Increases or decreases in VAS ratings between units were matched by parallel changes in cortisol levels and pulse rates. However, statistically significant differences between groups could not be shown for cortisol; extreme variances were found for cortisol levels in both groups.

Ratings on parents were similar to those of their children, but did not present any statistically significant changes (Table 1).

Discussion

The results suggests that psychological preparation prior to an operation for emergency appendectomy leads to decreased anxiety. As shown in Fig.4, the decrease in the children 's anxiety after the psychologic preparation (group 2, admission unit) is similar to the decreased anxiety in the unprepared group seen after the sedative premedication (group 1, operating unit).

In this study, the recording of VAS scores for the prepared group by nurses in the admission unit might have been biased, since the preparation program was given in the same unit. However, corresponding decreases in pulse rate, blood-pressure and cortisol level tend to support the VAS ratings by nurses in the admission unit. It was suggested in this study that preparation may reduce the need of premedication, but also that both preparation and premedication could be used.

FOLLOW-UP INTERVIEWS AFTER APPENDECTOMY

The purpose of this follow-up study was to investigate children's and parent's opinions of information given prior to an acute operation and their recollection of the hospitalization period.

Methods

Twenty-seven children operated on for appendicitis, and their parents, were interviewed three to six months after their hospital stay. Nine children had received only verbal information prior to operation, nine had been subjected to a preparation program given by a non-pediatric nurse, while still another nine had been given the same preparation by a pediatric nurse.

All the children and parents were subsequently interviewed using structured interviews. Questions centered on memories of pain, anxiety and nausea and were related to three distinct occasions: at home before admission, before anesthesia, and after surgery.

Results

The results of interviews done after surgery showed that children who had received the psychological preparation program remembered somatic symptoms, pain and nausea, and had a more realistic recollection of the procedure. They had also asked more questions and received more answers during their time in hospital. On the other hand, children who had been conventionally prepared primarily remembered their fear at home before admission to the hospital and before the operation.

More parents of children in the control group considered their children to be afraid during their stay at the hospital compared to parents in the prepared groups. No differences were found in children's reactions to preparation programs given by pediatric or nonpediatric nurses.

Discussion

The psychological preoperative preparation program seems to have had the effect that the subjected children were able to deal with their anxiety and fear at the hospital before discharge. These feelings were then forgotten and remained so when they were interviewed. Loss of fear and anxiety has also meant that these children could retain a more realistic memory of their hospitalization.

PREPARATION VERSUS PREMEDICATION (V)

The purpose of this study was to determine whether information prior to an emergency operation might reduce the need for sedative premedication to control anxiety and stress.

Methods

Thirty children (12 boys and 18 girls, aged 7 to 15 years) admitted to the hospital for acute pain, and then operated for appendicitis, were included in the study. They were randomly assigned either to a verbally prepared group, given narcotic-sedative premedication (control group I), or to a psychologically prepared group, given only atropine as premedication (group II). No child with peritonitis was included in the study, in order to avoid unnecessary delay of the operation and because a child in acute pain probably could not have used the information effectively.

The preparation program consisted of showing the material to be used for the procedure and a photo-album.

Anxiety was registered using a VAS- scale (see page 17). In the pediatric unit the nurse in charge first rated the children's and parents' anxiety levels separately on the VAS rating scale. The children's pulse and blood pressures were then recorded and, finally, both child and parent were asked: "How afraid are you?". They then rated their own anxiety also using a VAS measuring-stick. Children in both groups were rated by VAS before receiving either preparation or premedication at the pediatric unit. The different nurses evaluations, along with pulse and blood pressure, were recorded at four stages: in the pediatric unit, on admission to the operating unit, in the postoperative unit and again at the pediatric unit. The nurses doing the evaluations were trained on how to use rating scales prior to start of the study. When the child was admitted to the hospital, a needle was inserted and IV fluid started. Blood samples were drawn upon arrival in each new clinical unit and were analysed for serum cortisol.

Premedication

All patients received atropine sulphate (0.01 mg per kg body weight), which was given rectally to those weighing less than 30 kg and intramuscularly to all others. In group I received, in addition, diazepam (0.5 mg per kg body weight) and morphine (0.15 mg per kg body weight)

rectally, or, if the body weight exceeded 30 kg, meperidine (1 mg per kg body weight) and promethazin (0.5 mg per kg body weight) intramuscularly. Parents were present until the child anived in the operatingtheatre.

Results

Mean values and standard deviations of VAS ratings on children and parents done by nurses are given in Table 2.

Group	Pediatric Unit	Operating Unit	Postoperative Unit	Pediatric Unit
<u>Nurse rating</u>				
Children				
1	a 3.1 ± 1.6	2.7 ± 2.3	1.0 ± 0.9	1.3 ± 1.2
11	a 2.5 ± 1.7	2.7 ± 2.8	1.1 ± 0.8	1.5 ± 1.5
Parent				
1	2.2 ± 1.2	not done	1.6 ± 2.0	1.7 ± 2.8
	2.3 ± 1.6	not done	1.8 ± 1.9	1.8 ± 2.2
<u>Self rating</u>				
Children				
I	b 3.6 ± 2.5	2.9 ± 2.2	1.2 ± 1.3	not done
Parent	c 2.8 ±	2.9 ± 2.9	0.8 ± 0.8	not done
1	2.3 ± 1.9	not done	1.1 ± 1.1	not done
11	3.1 ± 1.9	not done	1.7 ± 2.4	not done

Table 2. Results are given as mean centimeters on the VAS Scale ±ISD. 0=very calm, very #raid. Statistical significance determined by two-tailedpaired t-test Group I given narcotic-sedative,group II preparation program. Using two-tailed paired I-test a 0.01), b 0.05), c (p< 0.001) between pediatric unit and postoperative unit.

Children in both goup were rated by VAS before receiving either preparadon or premedicaüon at the unit. Anxiety levels in both youps were found to be lower at the operating unit after preparation or premedication and showed further decrease at the postoperative unit in both groups. Statistically

significant decreases were found only between the pediatric and postoperative unit (0.01). Parents' VAS scores were **similar** to those of their children, but did not present any statistically significant changes (Table 2).

Children's VAS

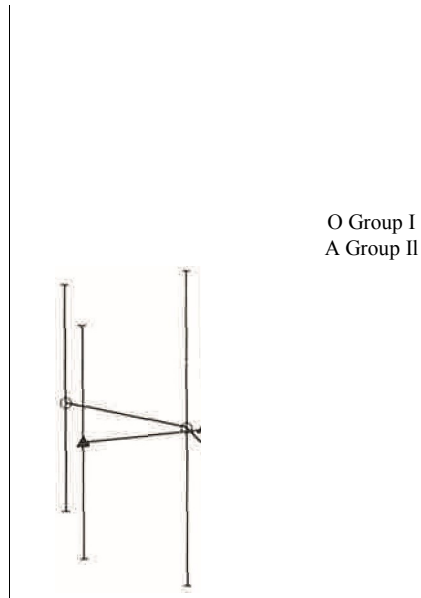

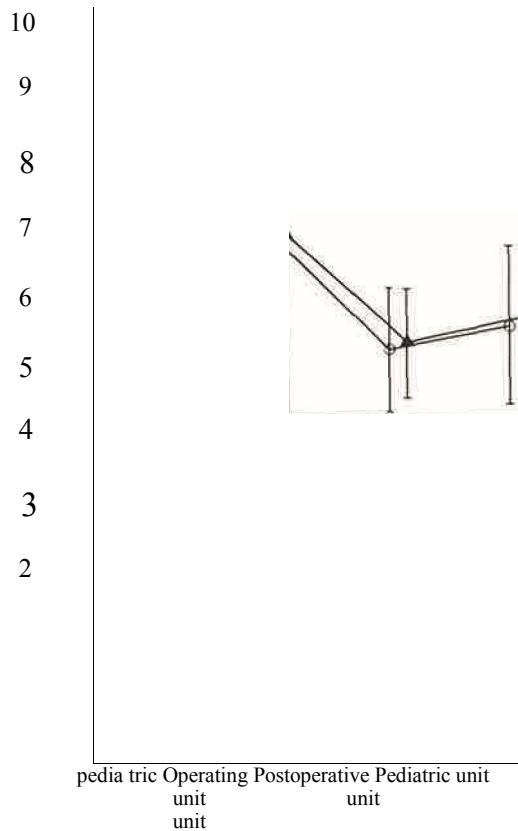

Fig 5. Children's selfratings on Verbal Analogue Scale (VAS) in four units. Results are given as mean \pm ISD. children are verbally prepared given narcotic-sedative as premedication. children prepared with the preoperative program and given only atropine as premedication. 0 —very calm, very draid.

Similar findings were seen for children's self radngs on the VAS, showing statistically significant decreases between pediatric unit and **postoperative** unit in both the unprepared group ($p < 0.05$), and the prepared group ($p < 0.001$), Fig. 5. There were no statistically significant differences between the two groups in any unit.

Cortisol and Groups	Pediatric Unit [nmol/L] a	Operating Unit nmol/L) b	Postoperative Unit [nmol/L]	Pediatric Unit [nmol/L]
I	515.9 ± 322.4 (131-1103)	40.8 ± 258.2 (9&935)	785 ± 316.4 (161-1443)	286.3 ± 174.9 (68-614)
II	578 ± 463.2 (102-1586)	661.7 ± 440 (124-1410)	846.9 ± 298.6 (412-1451)	565.5 ± 407.6 (105-1538)

Table 3. Results are mean ±ISD. Ranges of values are in parenthesis. Statistical significance was determined by two-tailed paired t-test and binomial test. Stress Hormone (Cortisol) determination in the Four Units.a (p<0.01) between pediatric unit and postoperative unit two-tailedpaired t-test. By two-tailed binomial test; b (p<0.05) operating unit versus postoperative unit, c (p<0.01) postoperative unit versus pediatric unit.

Cortisol concentrations were equal in both groups at the first measurement (pediatric unit preoperatively). Concentrations decreased in the control group between the pediatric and the operative units (probably due to premedication) and increased significantly again between the operative and post-operative units (p< 0.05). This finding was probably due to the surgery. Concentrations then decreased significantly between the post-operative and pediatric units (p<0.01). In group II cortisol increased between pediatric unit, operating and postoperative units and decreased in the pediatric unit postoperatively but these changes were not statistically significant (Table 3).

No significant differences were seen between the groups regarding need for postoperative analgesics, nor was it possible to identify any relationship between analgesic usage and VAS ratings.

Discussion

The result demonstrated that there were no statistically significant differences between the groups. Thus psychological preparation seems to be comparable to pharmacological premedication using narcotic-sedative drugs, but individual assessment must be carefully carried out to determine the individual needs of each child.

Familiarity with child development may provide a broad understanding of the behavior of children at different ages. Children who are upset because of unpleasant experiences from previous operations may benefit from sedatives. As always, individualized planning for each patient's needs is the best approach.

The value of a drug as premedication before anaesthesia depends largely on its sedative properties. Anesthesiologists have important responsibilities in the psychological preparation of the pediatric surgical patient.

PREPARATION FOR LUMBAR PUNCTURES (VI)

The purpose of this study was to determine whether specific information prior to lumbar puncture would reduce anxiety and improve cooperation. We also evaluated whether reinformation prior to repeated procedures was beneficial.

Methods

Thirty children were studied. All were admitted for treatment of leukaemia or lymphoma. These children were divided into three groups of 10 each.

Group 1 was the control group. These children were already in treatment including lumbar puncture (Lp), when the study began and were evaluated at one occasion only.

Group 2 was exposed to the preparation program by the program nurse on one occasion prior to the first Lp. These children were evaluated on three occasions.

Group 3 was exposed to the preparation program by the program nurse on three different occasions, prior to the first and the two following lumbar punctures. These children were also evaluated on all three occasions. The children in the prepared groups were randomly assigned to group 2 or 3.

The child's reactions during the three treatments were evaluated by parents and the nurse in charge using two rating scales, an anxiety and a noncooperative behavior scale. Each is a six-point scale (see page 22). Evaluations using the same scales were also done by two untrained observers watching a video uptake of the child's reactions during the lumbar puncture. After the procedure the child himself rated his own experience of pain on a Visual Analogue Scale (VAS).

Results

The ratings on the anxiety and noncooperation scales were found to have a **strong** association. Therefore these ratings have been combined into a single score (Fig. 6).

Noncooperation

5

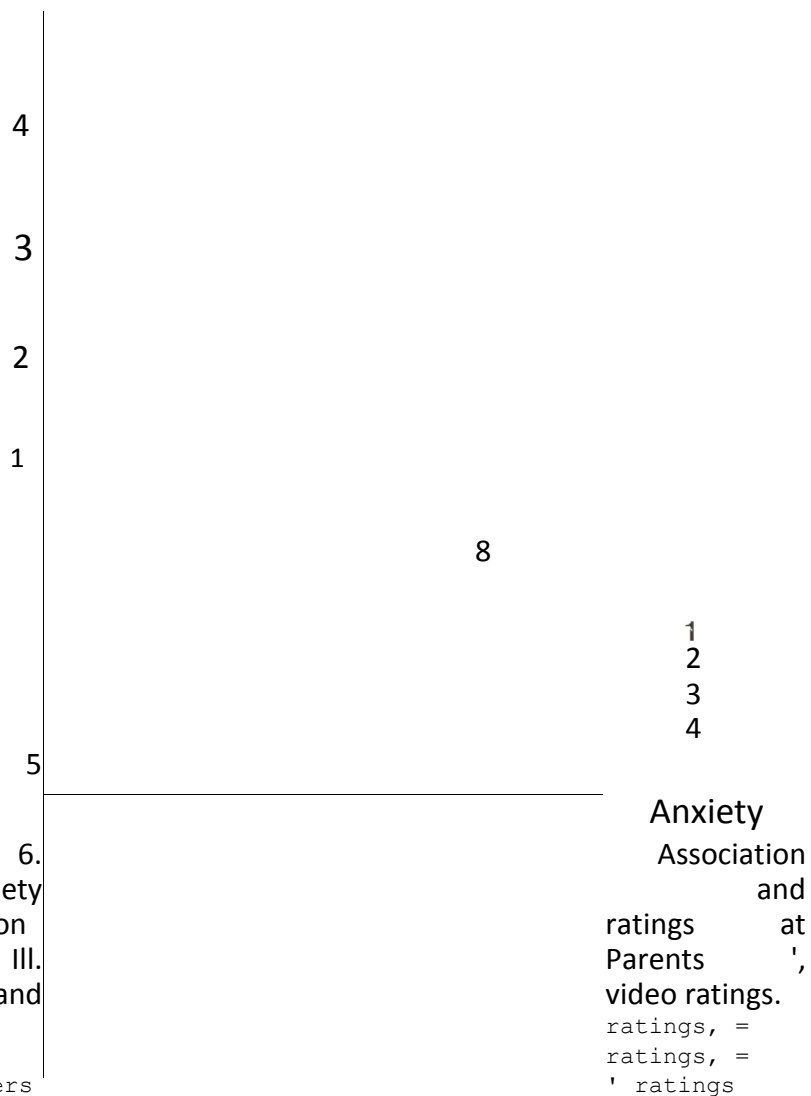

Also nurses' parents' and video observers' evaluations showed clear correlations: the ratings from these three observers have therefore been combined as "adult ratings".

In Table 4, mean adult scores for the whole material are presented by sex and age. We found that children under 8 years of age showed higher "adult ratings", that is less cooperation and more anxiety, at all occasions compared to older children ($p < 0.001$ at occasion I; $p < 0.05$ at occasions II and III). Children under 8 years of age also evaluated their own pain using higher VAS scores than those used by older children at all occasions ($p < 0.05$ at occasion I).

	Mean adult scores			Mean VAS-scores		
	occ 1	occ II	occ III	I	II	III
Boys	1.93	0.92	1.24	4.83	3.83	4.26
Girls	1.36	1.21	1.41	4.63	3.88	4.36
Age < 8 yr	2.76	1.47	1.80	5.82	4.09	4.38
Age ≥ 8 yr	0.41	0.50	0.73	3.44	3.56	4.21

Table 4. Mean adult and VAS-scores for the whole material at each occasion, by sex and age group. Significance levels were estimated using Mann-Whitney U test.

* = ($p < 0.05$), *** = ($p < 0.001$)

It was also possible to see a certain tendency toward lower adult evaluations (i.e. < 2.5) in association with high child VAS (i.e. > 4.5). Altogether, 27 such observations out of 70 were found for all occasions combined. The tendency toward "under-evaluation" by adults was consistently greater in group 2 compared to group 3 (Fig. 7).

VAS

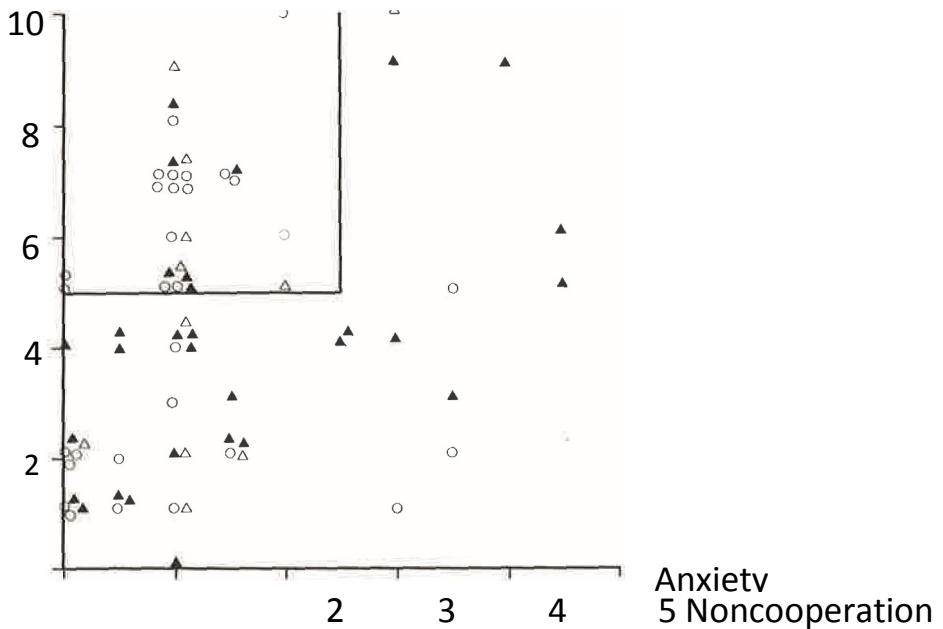

Fig.7. Children 's ratings on VAS and adults' combined rating on anxiety and noncooperation scales.

A = group 1 , children not prepared by program nurse (control group) O = group 2, children prepared by program nurse prior to first treatment A = group 3, children prepared by program nurse prior to each treatment

The children in group 3 had, because of more information episodes, a greater opportunity to talk their feelings and anxieties. During the study we found that the children 's comments changed on successive occasions. Prior to the first puncture, children in groups 2 and 3 had many questions, especially regarding the prospect of pain. After the preparation they were surprised that the procedure was not going to be worse. After the puncture they evaluated their own pain as "moderate".

During preparation prior to the second treatment, children in group 3 asked questions that did not center around pain any longer, but instead around the procedure (length of needle, how many minutes it would take

etc.). One child declined more information, but looked at the photos ("to be sure what was going to happen").

On the third occasion, two more children declined further information. After the puncture, these children evaluated their pain as "easy" or "no pain at all".

Discussion

We found in this study that the child's own perception of pain does not necessarily agree with his display of anxiety and noncooperation. We have also felt that the information process in itself has many beneficial effects on the child's development toward cooperation in stressful situations and may also help the child to express his/her feelings openly.

Regardless of the child's behavior during the lumbar puncture, it was interesting to observe the eagerness with which most children participated in the VAS evaluations. It is also of interest to note the greater use of full scale range by the children as compared to parents', nurses' and observers' (Fig. 7). All three groups of children may have more or less hidden their reactions during the procedures, but afterwards rated their own pain more realistically and "honestly".

During the information period in group 3 (most informed) the child's own questions changed from asking about pain to showing more interest in materials used during the procedure.

GENERAL DISCUSSION

Certain key factors can be expected to influence the child's suffering and behavior during a painful procedure. These include the child's previous experience and understanding of the procedure, the child's expectation of pain and thus level of anxiety and the child's cognitive status. It has frequently been suggested that psychological upset during hospitalization is, in part, a product of exposure to a variety of unfamiliar routines, procedures, people and

equipment. The purpose of psychological preparation is to prepare children prior to investigations and treatment in order to reduce anxiety, increase cooperation, and also to increase satisfaction with the provided information. The aim of this thesis has been to study whether a psychological preparation program can achieve these goals.

Reducing anxiety

In studies II, III and V the prepared groups showed significantly less anxiety when rated by trained nurses prior to and during the procedures. This agrees with earlier findings by Visintainer, Wolfer, Wells, Melamed and Mahaffy [44, 48, 79, 80, 83] who also found that a prepared group showed better cooperation and significantly less upset compared to controls. In studies by Cassell and Milton [15] and Campbell [13] children were investigated following admission for heart catheterization and subjected to a preparation program. Their results indicated that prepared children showed less emotional disturbance during the procedure and were also more willing to return to the hospital for further treatment. In our study II, where children were prepared for heart catheterization, we also found a reduced anxiety prior to the investigation. In studies III and V, self rating for anxiety were done by parents and children using VAS and were found to be reduced for the prepared group. Ratings on the anxiety and noncooperation scales in our study VI were found to be inter-related. This is also in agreement with earlier results reported by Campbell, Visintainer and Wolfer [13, 79, 83]. When the anxiety-noncooperation ratings by adults were compared to the children's self rating of pain in our study, no clear association was found.

The need for premedication

Premedication is usually given before surgery to reduce anxiety. Seeman and Rockoff [67] claim that premedication may give variable effects due to such uncontrolled factors as unpredictable surgical starting time or postoperative

sedation. This may constitute a reason for not giving routine premedication on the ward. It would therefore be of practical advantage if preparation could be shown to reduce the need for premedication. In our **retrospective** study I, we found that after preparation the children needed less premedication. This finding was based on a relatively large number of children; these cases were, however, reviewed retrospectively which may have led to some loss of information. In study III the psychological preparation was found to have reduced the level of anxiety prior to premedication to a level not seen in a control group until after premedication. In study V, which compares the psychologically prepared group with a premedicated group, no statistically significant differences were found between the groups. This can possibly be interpreted as evidence that preparation may be as effective as premedication, but since the groups are small we can only present the results as a suggestive tendency.

Another possible effect of premedication was noted in our study VI, where some of the children who had been premedicated before the previous attempt expressed fear prior to the current perhaps because their recollection of the earlier experience had been clouded by **premedication**; they seemed unable to remember the previous episode clearly .

To the best of our knowledge there have not been any other studies comparing the use of preparation and premedication, although Seeman and Rockoff suggested that such studies should be done [67].

Satisfaction with information

Campbell and Visintainer [13, 79] found in their studies that parents reported more satisfaction and less anxiety when they received some in-hospital preparation together with their child. Parents in the prepared groups were significantly better satisfied with the information given in our own studies II, III and V and they also evaluated their children as more relaxed and better prepared for the procedure. In study II, parents in the prepared group did not request further information after the session with the child, while several of

the parents in the control group asked for more information. However, the interviews concerning satisfaction with information in study II were done by the same nurse who had given the information and this may have introduced some bias. In study IV, the interviews regarding recollection of pain were carried out by psychology students, who were unaware whether the information program had been given or not.

Parents are usually interested in allowing their child to receive preparation. Some parents, however, are afraid that such information will increase the child's anxiety, possibly as a result of the parent's own anxiety. In such cases we have tried to describe to the parent the possible benefits of information prior to investigations, which usually has solved the problem.

Repeated information

The value of repeated information was investigated in our study VI of children undergoing frequently repeated lumbar punctures. In this study we found that while a few children rejected further information after one or two sessions, there were strong indications that a majority were in need of repeated information. These children, who had received repeated information, seemed better able to openly express their feelings and anxieties. Katz and Kellerman et al. [38, 39] concluded in their study of children undergoing repeated bone marrow aspirations that there was a significant relationship between anxiety behavior and the asking of questions. They also concluded

that children do not "habituate" (or become less distressed) over time with repeated procedures. This was also found in our study II, where children who had undergone heart-catheterization earlier still required more information and expressed anxiety.

Age groups

In study VI we found that children under 8 years of age were assigned higher "adult ratings", i.e. showed less cooperation and more anxiety, at all occasions compared to older children. These younger children also evaluated their own pain using significantly higher VAS scores than older children in the same study. This is in accordance with findings by Visintainer and Wolfer [79] who reported that the younger children in their study had significantly higher upset ratings and showed significantly less cooperation than older participants during blood tests or administration of preoperative medication. Katz et al. [38] also found a clear relationship between age and anxiety, with younger children exhibiting higher levels of distress than older children. They also found a tendency for females to display greater behavioral anxiety than males. These findings are also in agreement with our findings in study VI, in which girls at the third lumbar puncture were assigned significantly higher adult ratings than boys.

Other findings

We found, rather unexpectedly, a discrepancy between the children's own VAS ratings for pain and the corresponding combined "adult" ratings on the anxiety - noncooperation scales in study VI. The children made full use of the range provided by the VAS device (0-10) while "adults" made relatively little use of scores greater than 2 on the anxiety-noncooperation scales (from a possible range of 0-5). This may have disclosed a tendency on the part of the children in our study groups to successfully conceal some outward signals of pain. All three groups of children may have more or less hidden their

reactions during the procedures, but afterwards rated their own pain more realistically and "honestly". The presence of the video camera during the procedure may also have inhibited their behaviors.

These findings were not in agreement with Abu-Saad [1] who found in her study that there was a clear relationship between behavioral indicators (e. g. vocalizations, facial expressions, and body movement) registered by investigators and the child's indications on the pain scale, while she found no correlation between the child's physiological indicators of pain and responses on the pain scale.

We found a strong correlation between our adult observer categories in their independent assessment of anxiety-noncooperation in the children in study VI. This supports the validity of adult raters, indicating similar judgements by nurses, parents and the neutral video observers. The question about validity in pain measurements has recently been discussed by Patricia McGrath [46] who reviews the recent advances in the measurement of pain in children, and to the best of our knowledge no findings on correlation between different adult observers have been presented.

Difficulties with evaluations

Even after careful evaluation, the potentially confounding factors of illness, in combination with procedures and psychosocial adjustment, are complex phenomena that may have effected our data in unforeseen ways. It is also difficult to show statistically significant differences when the groups studied are both small and internally heterogeneous, or to judge what the effect might have been if the groups had been statistically "stronger". Such statistically "weak" trends as we have occasionally encountered in these studies constitute, none-the-less, the best available information at present, and should be regarded as an incitement to further research and methodological refinement.

Our use of multiple observers in studies II, III, V was motivated by practical considerations in the existing clinical situations but may have led to reduced consistency in the data. To counteract this risk the observers who evaluated the

children and parents received uniform instructions several times prior to the start of the study.

Conclusion

In each of the six studies reported here we have found some statistically significant evidence favouring the use of a preparation program for the delivery of information to children who are about to undergo painful or frightening medical procedures. Furthermore, the children in our prepared groups seemed to "feel better" after the information sessions, in some cases wanting to be informed several times (study VI) and were eager to take part in play-sessions using the doll in order to act out their previous or expected experiences. A number of questions still require further research in order to arrive at the best possible repertoire of preparatory programs for children of different ages, with different diagnoses, and in different treatment situations.

SUMMARY

In this series of studies we have attempted to evaluate the effects of a planned information program as compared to conventional verbal information.

In study I we investigated the number of children receiving premedication prior to uro-radiology examinations. A retrospective analysis of case records showed that less premedication had been used after introduction of the information program.

In study II children admitted to hospital for heart catheterization were alternately assigned to a group receiving conventional information or to a prepared group that received both verbal information and the preparation program along with their parents. Children who received the preparation program were found to show less anxiety prior to the procedure. Their parents were more satisfied with the information given than the parents in the control group.

In study III children scheduled for acute appendectomy were randomly assigned to a control group or to a prepared group. The stress levels of both child and parent were recorded using a Visual Analogue Scale (VAS) and physiological parameters on the child. The prepared group showed less anxiety, and a

corresponding effect was seen in the control group only after pharmacological premedication.

In study IV children and parents were interviewed following appendectomy using structured interviews concerning recollection of pain, anxiety and nausea. Children who had received the preparation program preoperatively remembered primarily their somatic symptoms, pain and sickness, while children in the control group remembered mainly their fear.

In study V we studied children who had been admitted to hospital for acute pain, and then operated on for appendicitis. The control group in this study received conventional verbal information and narcotic-sedative premedication. The prepared group received only atropine as premedication in conjunction with their psychological preparation. No statistically significant differences were seen between the groups. Thus psychological preparation seemed to be comparable to pharmacological premedication using narcotic-sedative drugs, assuming careful assessment to determine the individual needs of each child.

In study VI the value of preparation was studied in children undergoing a series of lumbar punctures. Three groups were compared: one group with prior experience of the procedure, a second group exposed to the preparation program prior to the first lumbar puncture only, and a third group exposed to preparation on three consecutive occasions. The groups were compared using anxiety and noncooperation scales. The child himself rated his own experience of pain using the Visual Analogue Scale. We found in this study that the child's own perception of pain did not necessarily agree with his display of anxiety and noncooperation. We also found that repeated information may help the child to express his feelings and anxieties more openly .

While doing these studies and preparing the children we felt that the information process in itself had a beneficial effect on the children 's development toward cooperation in situation. In all the studies we also found some statistical support for the use of psychological information programs.

POPULÄRVETENSKAPLIG SAMMANFATTNING

(Popularised summary in Swedish)

När barn kommer till sjukhus är det för de flesta en helt ny och okänd värld. Det har skrivits mycket om barn på sjukhus, deras rädsla och deras sätt att reagera inför nya situationer och upplevelser. Barnet är för de flesta en bekymmerslös tid i jämförelse med den vuxnes värld som är fylld av stress och ansvar. Men det finns tillfällen då även barnen kan hamna i **stressi** situationer. Dit hör sjukdom och sjukhusvistelse. Barnet kan drabbas av en känslomässig chock, panikkänsla, i samband med smärta och oförklarade medicinska behandlingar. Barnets reaktion på mss är betingad av barnets ålder, förståelse, fantasi och verklighetsuppfattning. Rädslan för det okända är svår i alla åldrar, men i synnerhet för barn som inte har ett verklighetstänkande och samma förståelse som en vuxen.

Ett barn klarar av och samarbetar bättre vid en undersökning eller behandling om han/ hon i förväg har blivit förberedd på vad som ska hända. Ärliga förklaringar är inte alls så skrämmande för ett barn som en överraskande händelse. Vad kan vi då göra för att minska barnets oro och ängslan inför nya händelser? Kan vi hjälpa barnen genom att överföra det okända till något de känner till?

Avhandlingen grundar sig på sex vetenskapliga uppsatser om förberedelse inför olika undersökningar och behandlingar. Det första delarbetet tar upp användning av premedicinering, inför njurröntgen, det andra delarbetet behandlar information inför hjärkateterisering och det tredje behandlar information inför en akut operation. Delarbete fyra är en uppföljning av arbete tre med intervjuer av barn och föräldrar om deras upplevelser efter en akut operationen. I arbete fem studeras information till barn i jämförelse med behovet av premedicinering preoperativt. Det sista arbetet behandlar information inför ryggmärgspunktion vid behandling av leukemi, och dessutom diskuteras frågan om mer information före upprepad behandling är av värde.

I samtliga delarbeten har samma informationsmetod använts, men metoden har modifierats efter olika undersökningar och behandlingar. Jämförelse har gjorts mellan en kontrollgrupp och en informerad grupp. Inna metod är en modifiering av en amerikansk metod framtagen av Petrillo & Sanger 1960.

Metoden består av:

- * Tillsammans med kallelsen från väntelistan vid en planerad inläggning bifogas en broschyr. Här beskrivs enkelt och lättförståeligt hur undersökningen går till. Broschyren är till för att föräldrarna hemrna skall kunna förbereda barnet lite inför den planerade sjukhusvistelsen.
- * Personalen informerar barnet med hjälp av det material, t.ex. venflon, narkosmask och sterila kläder, som skall användas vid ingreppet. Till sin hjälp har man en docka, beroende på barnets ålder, som man kan göra undersökningen på. Vid denna information har barnet också möjlighet att uttö-ycka sin oro och sina funderingar genom att göra egna undersökningar på dockan. Missförstånd kan härigenom klaras upp före undersökningen.
- * För att verklighetsanknyta denna information får barnet också titta i ett fotoalbum med bilder av ett annat barn som tidigare genomgått samma undersökning. Föräldrarna finns om möjligt med som passiva lyssnare och får då samma information som barnet. Detta kan vara av betydelse om barnet senare har frågor om undersökningen.

I första delarbetet beskrivs hur man efter det att informationsmetoden införts upplevde att det användes mindre premedicinering inför njurröntgen. Före införandet av den beskrivna metoden gavs lugnande medicin för att barnen skulle klara av att ligga still och samarbeta under röntgen. För att finna de barn som fått lugnande medicin inför njurröntgen studerades barnens journaler under en lika lång tid före som efter införandet av informationsmetoden. Man fann då att man minskat användningen av lugnande medicin från 33.1 % 20.570 efter införandet av informationemetoden.

I andra delarbetet användes informationsmetoden inför hjärkateterisering till barn och föräldrar. Barnen i den informerade gruppen visade sig vara lugnare inför undersökningen, och färre reagerade när de fick lokalbedövning i ljumsken. Föräldrarna i kontrollgruppen ville oftare få mer information, medan föräldrar i försöksgruppen i större utsträckning ansåg att informationen var tillräcklig. Föräldrarna i den informerade gruppen var något mer optimistiska till hur barnet skulle klara undersökningen. Det framgår också av undersökningen att även barn som varit med om undersökningen tidigare behöver ny information, liksom deras föräldrar.

I det delarbetet har vi studerat hur den specifika informationen påverkade barnen inför en akut operation. Bedömning av barnens och föräldrarnas reaktioner och upplevelser gjordes med hjälp av en stresskala. Den var graderad från 0=mycket lugn till 10=mycket rädd. Man mätte också barnens puls och blodtryck. På barnen togs blodprov för analys av stresshormoner. Vi fann att barnen i den informerade gruppen var mindre stressade efter att de blivit informerade. Man fann också ett positivt samband mellan barnets och förälderns stresskattning. Halten stresshormoner, däribland kortisol, visar en liknande kurva som stresskattningarna, men någon signifikant förändring av kortisolvärden kunde ej fås fram då flera av värdena var exu•ema.

I fjärde delarbetet gjordes en uppföljning med ett antal barn som blivit opererade akut och där barn och föräldrar intervjuades i hemmet efteråt. Frågorna berörde barnets rädsla och om de haft några somatiska besvär före och efter operationen. De barn som före operationen fått den utökade information hade efter operationen upplevt somatiska besvär såsom illamående och smärta. I samband med informationen före operationen hade barnen fått veta att sådana besvär skulle kunna Kontrollgruppen, som inte fått någon utökad information mindes mest rädsla som vid olika tillfällen under sjukhusvistelsen. Rädslan hos den informerade gruppen verkade ha försvunnit i samband med informationen medan **kontroll**troligtvis hade lämnat sjukhuset med en obearbetad rädsla, som de sedan kom ihåg.

I det tredje delarbetet hade vi funnit att den utökade informationen till barnen inför akut operation lett till att de var lugnare medan bamen i korm)llgruppen först var lugna efter premedicinering. Nu ville vi i arbete fem undersöka om det i vissa fall inte skulle behövas någon lugnande premedicinering om bamet fick ta del av utökad information. En grupp fick den utökade informationsmetoden men ingen lugnande medicin före operati och en annan grupp fick enbart muntlig information men lugnande premedicinering. Det visade sig att båda grupperna var lika lugna under behandlingen och här drog vi den slutsatsen att man i vissa fall inte behöver ge premedicinering om information före ingreppet verkar vara tillräcklig.

I avhandlingens sista studie studerades information till barn inför lumbalpunktion. Där försökte vi också studera om upprepad information var av värde. I denna undersökning fick barnen information av varierande omfattning inför planerade lumbalpunktioner. Föräldrar och personal bedömde barnets beteende under lumbalpunktionen. Bedömningar gjordes även av två observatörer från en videoupptagning. Det visade sig att alla tre bedömarna gjorde skattningarna av bamens beteende ungefär likvärdiga. I resultaten fann man att barnen under 8 år bedömdes som mer ängsliga. Barnen som var under 8 år bedömde också sin smärta som besvärligare jämfört med de äldre barnen. Det visade sig också att bamen bedömde sin egen smärta först som svår medan de barn som fick upprepad information efter hand upplevde sin smärta som mindre obehaglig.

Sammanfattningsvis har vi med några signifikanta fynd kunnat visa att en utökad infomation till barn före en undersökning eller behandling kan vara av värde. Vi har funnit att de barn som fått den utökade informationen har varit lugnare inför undersökningarna. Det finns flera frågor som vetenskapligt behöver belysas ytterligare för att bättre kunna verifiera värdet av att informera bam i olika åldrar, ba.rn med olika diagnoser och inför olika undersökningar.

ACKNOWLEDGEMENTS

I am deeply grateful to Associate Professor Gudrun Björkhem, my supervisor, for her enthusiasm, constructive criticism and unfailing support.

I want to thank Professor Nils-Rune Lundström for his support and for taking an active part in my work with this book.

I also want to express my thanks to Dr. Einar Ambjörnsson for help and also as collaborator in two articles.

To Dr. Katarina Hanséus, who encouraged me and helped me with practical issues.

I also want to express my sincere gratitude to:

Berit, Britt, Christina, Lena and Marianne, who have always been positive and tried to help me when calling for a "special person".

All those friends at the Departments of Pediatrics in Helsingborg and Lund, who always made me feel welcome in the wards and were an untiring source of support.

Ms. Gerd Storléér and colleagues at the Department of Health Care Development for encouragement and friendly jokes.

Professor Sten Lindahl who helped me in my preliminary "searching".

Associate Professor em. Herbert Enell, who inspired me to write scientific reports.

Med Dr h.c. Ivonny Lindquist, my "professional mother".

Professor Rolf Ekman, Associate Professor Bertil Rosberg, Associate Professor Bo Fredrikzon and Assistant Professor Thomas Wiebe, for good and interesting collaboration.

Mr. Jarnes Bergseng, for statistical and linguistic consultation.

Ms. Pia Lilja, for writing the manuscript accurately and with great enthusiasm.

Ms. Mia Jacobsson for valuable advice on interpretation of psychological aspects of child development.

Lennart and Edwina, for being my family.

My mother and the memory of my father, for support and care from the very beginning.

This work was financially supported by grants from the Medical Faculty of the University of Lund, The General Hospital in Helsingborg, First of May Flower Annual Campaign for Children's health, Children's Cancer Foundation, the Swedish Cancer Society (project # 2356B87-01PA) and the Swedish Nurses' Association.

REFERENCES

1. Abu-Saad H. Assessing Children's Responses to Pain. *Pain* 1984; 19: 163-171
2. Atkins D M, Patenaude A F. Psychosocial Preparation and Follow-up for Pediatric bone marrow patients. *Amer. J. Orthopsychiatr.* 1987; April 57 (2): 246-252.
3. Atkins D M. Evaluation of Pediatric Preparation Program for Shortstay Surgical Patients. *J Ped Psychol.* 1987; 12 285-290.
4. Azarnoff P, Woody P D. Preparation of children for Hospitalization in Acute Care Hospitals in the United States. *Pediatrics* 1981; 68 (3): 361-368.
5. Barker R A, Nisbet H I A. The objective measurement of sedation in children. A modified scoring system. *Canad. Anaesth. Soc. J.*, 1973; 20 599-606.
6. Bates T A, Broome M. Preparation of children for Hospitalization and Surgery: A review of the literature. *J Ped Nurs* 1986; 1 (4): 230-9.
7. Betz C L. Teaching children through play therapy. *AORN J* 1983; 38 4):709-721.
8. Beverly B. The effect of illness upon emotional development. *J Ped* 1936; 8 533-543.
9. Blom G E. The reactions of hospitalized children to illness. *Pediatrics* 1958; 22: 590-200.
10. Broome M E, Hellier A P. School-age children's fears of medical experiences. *Iss compr ped nurs* 1987; 10: 77-86.
11. Brown D, Peake J. Presurgical Education. *AORN J* 1984; 39 (7):1163-1171.
12. Brown S R. An Anxiety reduction technique during lumbar punctures in infants and toddlers. *J ass ped oncol nurs* 1984; 1 (3): 24-25.

13. Campell L, Clark M, Kirkpatrick S.E. management a-aining for parents and their children undergoing cardiac catheterization. *Amer J Gthopsychiat.* 1986; 56 234-243.
14. Carmel C, Mahan C, Mahan K. Patient Preparation in Pediatric Surgery. *Clin Ped Med Surg.* 1987; 4:1-9.
15. Cassell S, Milton P. The role of puppet therapy on the emotional responses of children hospitalized for cardiac catheterization. *J Ped* 1967; 71 (2) :233-9.
16. Chan J. Preparation for Hospitalisation, Procedures and Surgery through play. *Austral Nurs J* 1976; Oct: 41-44.
17. Clarke P R F, Spear F G. Reliability and sensitivity in the selfassessment of well-being. *Bull Brit psych soc.* 1964; 17 (55): 18A.
- 1 8. D'Antonio I J. Therapeutic use of play in hospital. *Nurs clin North America* 1984; 19 351-359.
19. Davies C. Mother's anxiety may increase child's distress. *Nursing mirror* 1984; 158 (18): 30-31.
20. Diniaco M, Ingoldsby B Parental presence in the recovery room. *AORN J* 1983; 38 685-93.
21. Eckhardt L, Prugh D. Preparing children psychologically for painful medical and surgical procedures. *Psychosocial Aspects of Pediatric care.* Grune & Stratton, New York 1978: 75-81 (book chapter).
22. Eland J M. Pain. In: L.Hart, J. Reese and M. Fearing (Eds), *Concepts Common to Acute Illness*, Mosby, St. Louis, MO, 1981.
23. Eland J M, Anderson J E. The experience of pain in children. In Jacox AK (ed): *A Sourcebook for Nurses and Other Health Professionals.* Boston, Little, Brown & co, 1977; 453-473.
24. Elander G, Lindberg T, Qvarnström B. Pain Relief in Infants After Major Surgery: A Descriptive Study. *J Surg* 1991; 26(2): 128131.

25. Elsass P, Duendal H, Friis B, Möller W and Sørensen B. The psychological effects of having a contact-person from the anesthetic staff. *Acta Anaesth Scand* 1987; 31 584-6.
26. Ferguson B. Preparing young children for hospitalization: A comparison of two methods. *Pediatrics* 1979; 64 (5): 656-663.
27. Fischerman S E, Friedland G W. Psychology aspects of dealing with children in urology. *Urology* 1986; 27 (5): 478-481.
28. Freud A. The ego and the mechanism of defense. New York: International Universities Press 1968.
29. Genti G, Balint G, Borbas E. Visual analogue pain scale. *Annual of the Rheum ms* 1980; 39 414 (Letter).
30. Giødesen.L. När barn ska in på sjukhus. Natur & Kultur, Stockholm, 1981.
31. Haegerstam G. Smärta hos barn Klinik & Terapi 1985; 2: 28-30.
32. Hayes V. Knox J. Reducing hospital-related stress in parents of children with cancer. *Can Nuge* 1983; 79 (10): 24-8.
33. Huskinson E C. Measurement of pain. *The Lancet* 1974; 2, Nov 9:1127-1131.
34. Jackson S, Maggard D. Psychological Preparation: A new approach to ambulatory care. *J Post Anaesth Nurs.* 1986; 1 (4): 271-3.
35. Jay S M, Elliott C H, Ozolins M, Olson R A, Pruitt S D. Behavioral management of children 's distress during painful medical procedures. *Behav. Res. Ther.* 1985; 23 513-520.
36. Jay S M, Ozolins M, Elliott C H. Assessment of children 's distress during painful medical procedures. *Health Psychology.* 1983; 2 (2): 133-147.
37. Jessner L, Blom G E, Waldfogel S. Emotional Implications of tonsillectomy and adenoidectomy on children. *Psychoanalytic study of the child.* 1952; (7): 126-169.(Book chapter).

38. Katz E K, Kellerman J, Siegel S. Behavioral Distress in Children with cancer Undergoing Medical rocedures: Developmental Considerations. *J Consul Clin Psychol.* 1980; 48: 356-365.
39. Kellerman J, Zeltzer, Ellenberg L, Dash J. Adolescents with cancer. *J adolesc health care* 1983; 4: 85-90.
40. Klackenberg G. Psykiska skador av sjukhus- och barnhemsvård. *Sv Läkartidning* 1946.
41. Lindquist I. Terapi genom lek. *Esselte studium* 1974..
42. Lundberg U. Sex differences in behaviour pattern and catecholamine and cortisol excretion in 3-6 year old day-care children. *Biol Psychol.* 1983; 16: 109-117.
43. Lutz J W. Helping Hospitalized Children and their Parents Cope with painful Procedures. *J Ped Nurs.* 1986; 1: 24-32.
44. Mahaffy P R. The effects of hospitalization on children admitted for tonsillectomy and adenoidectomy. *Nurs res* 1965; 14 (1): 12-19.
45. Mahan C, Mahan K. Patient Preparation in Pediatric Surgery. *Clin Pod Med surg* 1987; 4 1-9.
46. McGrath. P J, Craigh K D. Developmental and Psychological Factors in children 's pain. *Ped Clin of North America.* 1989; 36: 823-850.
47. Melamed B, Meyer R, Gee C, & Soule L. The influence of time and the type of preparation on children's adjustment to hospitalization. *J ped psychol.* 1976; 1 31-37.
48. Melamed B, Siegel L. Reduction of anxiety in children facing Hospitalization and surgery by use of filmed Modeling. *J Consul Clin Psychol* 1975; 43 511-521.
49. Meng A, Zastowny T. Preparation for hospitalization: A stress Inoculation training program for parents and children. *Matern Child Nurs J* 1982; 11 87-94.

50. Peüillo M, Sanger S. Emotional Care of the hospitalized children. ed 2. Philadelphia, JB Lippincott Co 1980.
51. Piaget J. The origin of intelligence in children. New York: University Press 1952.
52. Pickar D, Cohen M R, Dubois M. The Relationship of Plasma Cortisol and β -endorphin Immunoreactivity to surgical and Postoperative Analgesic Requirement. Gen Hosp Psychü 1983; 5: 93-98.
53. Plank E. Working with children in Hospitals, ed 2. Chicago, Year Book Medical Publishers Inc., 1971.
54. Poster C E. Stress Immunization: Techniques to help children Cope with Hospitalization. Matern Child Nurs J 1983; 12 (2): 119-134.
55. Poster E C, Betz C L. Allaying the anxiety of hospitalized children using stress immunization techniques. Comprehen Ped Nurs 1983; 6: 227-233.
56. Poznanski E O. Children 's reactions to pain: A psychiatrist's perspective. Clin Ped.1976•, 15 (12): 114-19.
57. Prugh D G, Staub E M, Sands H H, Kirschbaum R M, Lenihan E A. A study of the emotional reactions of children and families to hospitalization and illness. Amer J Orthopsych 1953; 23: 7C 106.
58. Ravenscroft K. Psychiatric consultation to the child with acute physical trauma. Amer J Orthopsych 1982; 52 (2): 298-307.
59. Ridley-Johnson R, Melamed B G. Behavioral methods and research issues in Management of child Patients. Anesth prog 1986; 33 (1); 1723.
60. Ritchie J A. Preparation of toddlers and preschool children for hospital procedures. Can Nurs 1979; december: 0-32.
61. Saxen M, Harvan M. Easy ways to reduce the stress of treating children. Dental management 1983; 10: 20-22.
62. Scherer M W, Nakamura C Y. A Fear Survey Schedule for Children (FSS-FC): A Factor analytic Comparison with Manifest Anxiety (CMAS). Behav Res & Therapy, 1968; 6: 173-182.

63. Schreier A, Kaplan D. The Effectiveness of a preoperation Preparation program in reducing Anxiety in children. CHC 1983; II (4): 142-147.
64. Schultz J B, Raschke D, Dedrick C, nompson M. The effects of a preoperadonal puppet show on anxiety levels of hospitalized children. J ACCH 1981; 9 118-121.
65. Schwartz B H, Albino J E Tedesco L A. Effects of psychological preparation on children hospitalized for dental operations. J Ped 1983; 102 634-638.
66. Scott P J, Huskinson E C. Measurement of functional capacity with Visual Analogue Scales. Rheumat Rehab 1977; 16(4): 257-
67. Seeman R G, Rockoff M A. Preoperative Anxiety: The Pediatric Patient.Int. Anesthesiol. Clin. 1986; 24 (4): 1-15.
68. Seldrup J. Comparison between Psychician and Patient Completed Visual Analogue Scales. J Int Med Res 1977; 5 55-60.
69. Sigurdsson G H. Enflurane and Halothane anaesthesia in children. Lund, 1983, 1-107. Diss.
70. Skipper J K, Leonard R C, Rhymes J. Child Hospitalization and Social teraction:Adaptation and Satisfaction. Medical Care 1968; 5 (6): 496506.
71. Stenbak E. Forberedelse af raske børn til hospitalsmiljøet. én model til forebyggelse af børns negative reaktioner på hospitalsindlæggelse. Tidsskrift for sygeplejerske 1980; 10: 3-11.
72. Stenbak E. Skal indlagte børn behandles efter myter eller behov. Sygeplejersken 1982; 12: 4-16.
73. Stuart H C, Stevenson S S. Physical growth and development. 1-1, p 141. Pa, W.B. Saunders co, Philadelphia, 1954.
74. Tarnow J D, Gutstein S E. Children's Preparatory Behavior for Elective Surgery. J Amer Ac Child Psych 1983; 22 (4): 365-369.
75. Timmerman R R. Preoperative fears of older children. AORN J 1983; 38 827-834.
76. Vaughan G F. Children in hospital. The Lancet 1957; June 1: 11171120.

77. Venham L L, Gaulin-Kremer E, Munster E, Bengston-Audia D, Cohan J. Interval rating scales for children 's dental anxiety and uncooperative behavior. *Ped Dent* 1980; 2 195-202.
78. Vernon D T S, Gaulin-Kremer E, Munster et al. The psychological responses of children to hospital. Springfield, Illinois, Charles Thomas 1965, chapter 11, 8-24.
79. Visintainer M A, Wolfer J A. Psychological Preparation for Surgical Pediatric Patients: The effect on children's and parents' Stress Responses and Adjustment. *Pediatrics* 1975; 56 (2): 187-202.
80. Wells J K, Howard G S, Nowiin W F, Vargas M J. Presurgical Anxiety and Postsurgical Pain and Adjustment: Effect of a stress Inoculation Procedure. *J Consul Clin Psychol* 1986; 54 (6): 831-835.
81. Wells R D, Schwebel A I. Chronically ill children and their Mothers: Predictors of resilience and vulnerability to hospitalization and surgical stress. *J dev behav ped* 1987; 8 (2): 83-89.
82. Wilkie D L, William L, Holzemer, et. al. Measuring pain quality: validity and reliability of children 's and adolescent'pain language. *Pain*. 1990; 41: 151-159.
83. Wolfer J, Visintainer M. Prehospital Psychological Preparation for Tonsillectomy Patients: Effects on children 's and Parents 'adjustment. *Pediatrics* 1979; 64 (5): 646-655.
84. Wolfe V V, Blount R L, Saylor C F, Dufour D, Finch A J. Nurses' Perceptions of Stress-Reduction techniques. In *Ped Oncol* 1987; 4 (12): 9-13.
85. Zeltzer L K, Jay S M, Fisher D M. The Management of pain associated with Pediatric procedures. *Ped Clin of North America*. 1989; 36: 941-

86. Zweig D C. Reducing stress when a child is admitted to the hospital.
MCN 1986; 11(1): 24-