



LUND UNIVERSITY

Redox Regulation and Stress Responses - Studies in *Bacillus subtilis*

Larsson, Jonas

2005

[Link to publication](#)

Citation for published version (APA):

Larsson, J. (2005). *Redox Regulation and Stress Responses - Studies in Bacillus subtilis*. [Doctoral Thesis (compilation), Department of Biology]. Cell and Organism Biology Lund University Sölvegatan 35 SE-22362 Lund.

Total number of authors:

1

General rights

Unless other specific re-use rights are stated the following general rights apply:

Copyright and moral rights for the publications made accessible in the public portal are retained by the authors and/or other copyright owners and it is a condition of accessing publications that users recognise and abide by the legal requirements associated with these rights.

- Users may download and print one copy of any publication from the public portal for the purpose of private study or research.
- You may not further distribute the material or use it for any profit-making activity or commercial gain
- You may freely distribute the URL identifying the publication in the public portal

Read more about Creative commons licenses: <https://creativecommons.org/licenses/>

Take down policy

If you believe that this document breaches copyright please contact us providing details, and we will remove access to the work immediately and investigate your claim.

LUND UNIVERSITY

PO Box 117
221 00 Lund
+46 46-222 00 00

Redox Regulation and Stress Responses

- Studies in *Bacillus subtilis*

By Jonas T Larsson
Cell and Organism Biology, Lund University



Doctoral dissertation in Microbiology
Department of Cell and Organism Biology

By due permission of the Faculty of Science at Lund University, to be defended in public in the Biology lecture hall, Sölvegatan 35, Lund, on October 14, 2005 at 9.00 am. The faculty opponent is Prof. Dr. Uwe Völker, Laboratory for Functional Genomics, Medical School Ernst-Moritz-Arndt-University, D-17489 Greifswald, Germany

Front cover: Electron micrograph of sporulating *Bacillus subtilis*. Magnification level ~80,000. Micrographs were done at the department of Cell and Organism Biology with practical help from Rita Wallén.

Back cover: 3D alignment of the truncated haemoglobin YjBI from *Bacillus subtilis* (brown) to myoglobin from sperm whale (blue).

© 2005 Jonas T Larsson

Department of Cell and Organism Biology
Lund University
Sölvegatan 35
SE-223 62 Lund
Sweden

ISBN 91-85067-24-5
Printed by KFS AB, 2005

Table of Contents

Chapter 1 Introduction	1
1.1 Energy conservation	2
1.2 Aerobic respiration.....	4
1.3 Anaerobic respiration	6
1.4 Fermentative metabolism.....	7
Chapter 2 Redox regulation	8
2.1 Redox sensors involving iron-sulphur proteins.....	8
2.2 Thiol based sensors	9
2.3 Flavin-containing sensors	10
2.4 Haem	11
2.4.1 PAS domains.....	12
2.4.2 Globin-coupled sensors	13
2.5 Q-pool.....	13
2.6 Pyridine nucleotides.....	14
Chapter 3 Stress responses.....	16
3.1 Oxidative stress	16
3.2 Nitrosative stress.....	17
Chapter 4 Redox sensing in gram-negative bacteria	20
4.1 γ -proteobacteria – <i>E. coli</i>	20
4.1.1 FNR	20
4.1.2 ArcAB.....	21
4.1.3 Dos.....	21
4.2 α -proteobacteria – <i>R. sphaeroides</i>	22
4.3 α -proteobacteria – <i>B. japonicum</i> , <i>S. meliloti</i>	23
Chapter 5 Redox regulation and stress responses in <i>B. subtilis</i>	25
5.1 Cytochrome <i>bd</i>	26
5.2 The truncated haemoglobin, Yjbl	27
5.3 ResDE-FNR-ArfM.....	28
5.4 Rex	30
5.5 The σ^B general stress regulon	32
5.6 Spx.....	34
Chapter 6 Summary of Papers.....	35
Chapter 7 Acknowledgments.....	37

List of papers

This thesis is based on the following papers, referred to in the text by their Roman numerals: **Paper I** is an uncorrected proof from the publisher.

- I. **Larsson, J. T., A. Rogstam, and C. von Wachenfeldt.** 2005. Coordinated patterns of cytochrome *bd* and lactate dehydrogenase expression in *Bacillus subtilis*. *Microbiology* **151**:3323-35.
- II. **Larsson, J. T., A. Rogstam, P. Kjelgaard, and C. von Wachenfeldt.** 2005. *Bacillus subtilis* possess both constitutive and inducible elements for alleviation of nitrosative stress. Manuscript.
- III. **Larsson, J. T., A. Rogstam, and C. von Wachenfeldt.** 2005. YjbH is a novel negative effector of the global transcriptional regulator, Spx, in *Bacillus subtilis*. Manuscript.

“Happy is he who gets to know the reasons for things.”
Virgil (70-19 BC) Roman poet.

Chapter 1 Introduction

Antonie van Leeuwenhoek (1632 - 1723) was an atypical scientist of his time; tradesman in textiles, no formal education, no language skills except Dutch, but an eager mind for knowledge and a mind free of the scientific dogma of the day. Antonie van Leeuwenhoek had as a hobby to grind optic lenses and he built a great number of extraordinary microscopes, which he examined most everything with. In some experiments on pepper, which were performed in order to discover if the pungent taste was caused by small spikes on the grains, van Leeuwenhoek put peppercorns in water and let them soften for three weeks. When he observed the water with his microscope the first bacteria or “*animalcules*” were observed by man. His description read:

I looked upon it the 24. of April, 1676. and discern'd in it to my great wonder, an incredible number of little animals, of divers kinds; and among the rest, some that were 3 or 4 times as long as broad; but their whole thickness did, in my estimation, not much exceed that of the hair of a Louse. They had a very pretty motion, often tumbling about and sideways; and when I let the water run off from them, they turned as round as a Top, and at first their body changed into an oval, and afterwards, when the circular motion ceased, they returned to their former length.

The 2nd sort of creatures, discover'd in this water, were of a perfect oval figure, and they had no less pleasing or nimble motion than the former; and these were in far greater numbers. And there was a 3rd sort, which exceeded the two former in number; and these had tails also, like those I had formerly observ'd in Rain-water.

The 4th sort of creatures, which moved through the 3 former sorts, were incredibly small, and so small in my eye, that I judged, that if 100 of them lay one by another, they would not equal the length of a grain of course Sand; and according to this estimate, ten thousand of them could not equal the dimensions of a grain of such course Sand.

There was discover'd me a fifth sort, which had near the thickness of the former, but they were almost twice as long.

Antoine van Leewenhoek (1632 - 1723)[147]

Indeed, some progress has taken place since the days of van Leeuwenhoek but the fascination for the loved and hated bugs is as big as in the seventeenth century with the *animalcules*. The prokaryotes are some of the most remarkable organisms in the biosphere, thriving in almost any environment, even ones that have no possibility to support other life forms. At the bigger scale, prokaryotes thrive from Arctic cold to superheated springs, from anaerobic deep ocean mud to the Atacama Desert in Chile, which never sees rain. However, maybe an even grander challenge exists for the cells in the wildly fluctuating microenvironment at the micrometer scale, where radical changes can occur on a very short time scale. One of the most crucial factors



governing survival and ability to stay competitive in nature is the ability to sense and quickly respond to these environmental changes.

Redox reactions are central to all organisms to sustain life. Both anabolic and catabolic metabolism depends on them. It is thus vital to sense and adjust the redox balance in the cell. One major factor affecting the redox status is the level of oxygen present. Transitions between different oxygen concentrations change the redox status and among other things, confer a stress upon the cells. A stress that ultimately leads to altered expression levels of genes necessary to cope with the new conditions. In this thesis different aspects of what ultimately causes stressful situations, and what bacteria can do to counter them are analysed.

Our research presented in **Paper I** has revealed that when transferring the soil bacterium *Bacillus subtilis* from an environment with plenty of oxygen to an environment with a low amount of oxygen many things take place. We have focused on a redox-sensing protein that adjusts the cells in a way that enables them to conserve energy by means other than aerobic respiration. The protein that coordinates the regulation affects three systems. The first system extends the machinery for oxygen-dependent energy retrieval to function when only a small amount of oxygen is present. The second system helps the cells to continue produce energy even if no oxygen is left. The third one may enhance the regeneration of an energy-carrying molecule important for both previous systems.

The second paper (**Paper II**) deals with the stressful conditions encountered when cells are facing damaging nitrogen compounds. We show that the cellular response involves two systems. One is an inducible system involving a haemoglobin-like protein for direct removal of the reactive compounds. The other system confers a constitutive protection.

In the last paper (**Paper III**) we show that a hitherto uncharacterised protein has a key role in the control of a global regulator involved in disulphide management.

1.1 Energy conservation

One of the unifying principles in biology is that life is sustained by the conservation of energy. This conservation is made possible in a number of ways where respiration by oxidative phosphorylation is one of the most efficient methods. The common “currency” of the cell is adenosine 5'-triphosphate (ATP), which is the most important energy carrier in living organisms.

How do bacteria conserve the energy from catabolism of high energy compounds to lower energy ones? The unifying principle is to create a chemiosmotic gradient across a barrier, and in bacteria this would be the cytoplasmic membrane. The chemiosmotic theory for biological energy transduction was first suggested by Peter Mitchell in 1961 [96], a discovery that in 1979 rendered him the Nobel prize. In his original hypothesis he described the respiratory chain as a series of redox loops where electrons were recruited on the outside of the membrane, transferred to the inside and finally co-transported back to the outside with protons in the form of the lipophilic molecule, quinone. This reaction assumes pairs of enzymes with the active sites for substrate and quinone on opposing sides of the membrane. Mitchell's hypothesis was later modified to include proton pumping enzymes and the Q-cycle. In 2002, Jormakka and co-workers provided structural insights into Mitchell's 30 year old theory [70]. The group showed

that in the enteric bacterium *Escherichia coli*, the enzymes Fdh-N and Nar build a loop with formate consumed in the periplasmic space and nitrate reduction occurring in the cytoplasm (Figure 1).

The chemiosmotic gradient (or PMF, proton motive force) is created not only by displacing protons from the inside to the outside of the membrane but also by conversion of protons to non-charged compounds in the cytosol. Chemically, the most common reaction is to oxidise a hydrogen atom carrier like NADH, succinate or glycerol-3-phosphate on the cytosolic side of the membrane and pass the electrons through a series of electron carriers with increasing redox potential. All while protons are deposited on the outside of the membrane. In the last step, the electrons are used to reduce a final electron acceptor located in the cytosol. The PMF formed across the membrane is used for a number of things, including flagella motion [88], solute transport and production of ATP from ADP by the F_1F_0 ATP synthase [1].

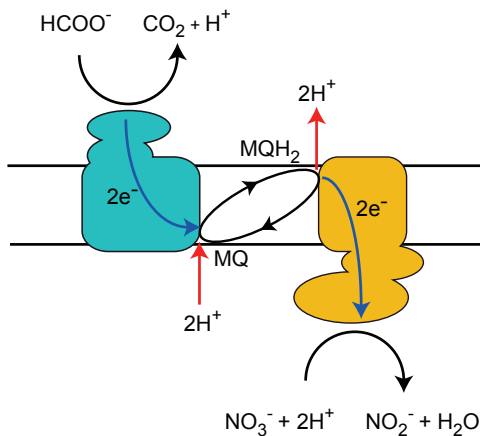

Figure 1 | Schematic drawing of a redox loop. The anaerobic respiration of *E. coli* conserves energy from formate in this system by the net movement of protons and negative charges across the membrane. The energy conserved by the increased PMF can subsequently be used by e.g. the F_1F_0 ATP synthase.

In most cases the creation of PMF includes a chain of enzymes (ETC, electron transport chain), each one trapping some of the energy of the starting compound. Many bacteria have multiple, branched pathways for electron transfer, meaning that they can swap enzymes in the chain in order to use the best combination for the current conditions. The branching includes all steps in the pathway, from numerous low-potential reductants to terminal electron acceptors. This arrangement allows for having enzymes with different catalytic efficiencies and affinities for their substrate. An ETC is here exemplified with the electron transport chain from *B. subtilis* (Figure 2).

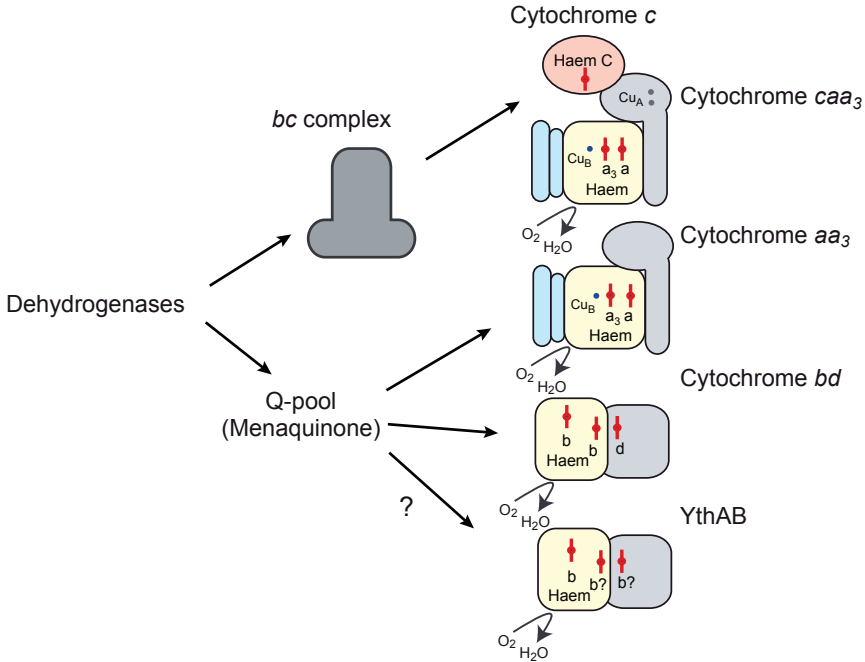

Figure 2 | Schematic drawing of the aerobic electron transport chain of *B. subtilis*.

1.2 Aerobic respiration

In aerobic respiration, dioxygen is used as the final electron acceptor. The possible amount of energy that can be conserved through a redox reaction is the difference between the electrostatic energy stored in the starting and ending substance. Since the usable energy of the O₂/H₂O redox couple is among the highest in biological systems, aerobic respiration has the potential to result in a very high energy yield (Table 1). Cells wishing to be competitive should accordingly have a regulatory machinery to favour aerobic respiration when O₂ is present.

The general formula for aerobic respiration is, $O_2 + 4H^+ + 4e^- \rightarrow 2H_2O$ and in this reaction the four electrons are collected from the inside of the cell and thus contributes to an increased PMF.

The mitochondrion can be thought of as a streamlined intracellular factory for energy conservation in a eukaryotic cell. The environment is stable and the enzymes tuned to work in this environment. The four enzymes comprising the basic mitochondrial respiratory chain are well characterized [1, 130] and consist of NADH:ubiquinone reductase, succinate dehydrogenase, cytochrome *bc*₁ and cytochrome *c* oxidase (Figure 3).

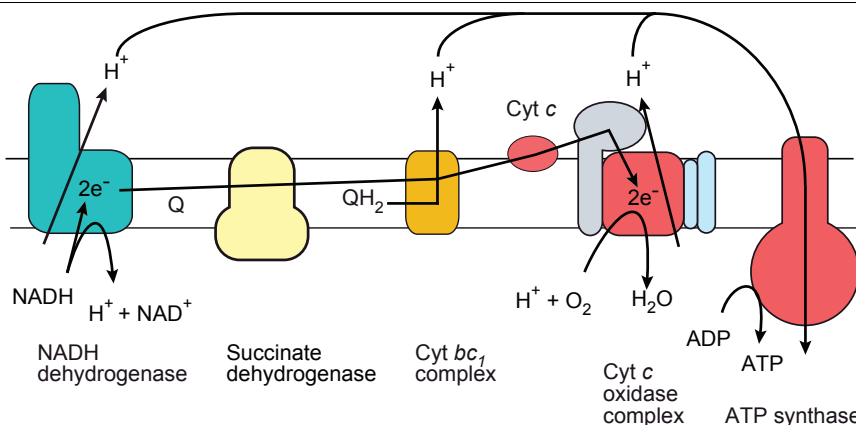

Figure 3 | Schematic drawing of the respiratory chain in the inner membrane of the mitochondrion. Electrons are obtained from NADH by the activity of a dehydrogenase and subsequently passed via a series of reactions to the cytochrome *c* oxidase, finally ending up reducing dioxygen to water. Protons are at the same time translocated over the membrane. Both these reactions contribute to the PMF. The gradient can later be used to create energy by e.g. conversion of ADP to ATP, catalysed by the ATP synthase.

The branched ETC present in many bacteria often contains several terminal oxidases (Figure 2), which can be grouped into two main types based on the organisation of the catalytic reaction centre; the haem-copper and the *bd*-type enzymes (Figure 4). In contrast to the haem-copper enzymes, the latter subgroup does not contain any copper atoms in the reaction centre but probably replaces the Cu_B atom with a second haem. Haem-copper oxidases are found at most branches of the tree of life, while *bd*-type oxidases are most commonly found in bacteria and archaea. The *bd*-type oxidases are often – but not always – expressed during low oxygen tension [26, 149]. My own work has involved the regulation of a quinol oxidase belonging to the cytochrome *bd* family (**Paper I**).

Terminal oxidases are also classified as cytochrome *c* oxidases or quinol oxidases based on the nature of the molecule that donates electrons to the enzyme. Haem-copper oxidases can be of either cytochrome *c* or quinol type while *bd*-type oxidases always use quinol for electrons.

Haem-copper terminal oxidases have the possibility to concomitantly with the consumption of electrons translocate or “pump” H^+ ions across the cytoplasmic membrane (Figure 3). The *bd*-type cytochromes do not pump protons and therefore have a lower total energetic efficiency compared to the haem-copper type oxidases. On the other hand, this may be compensated by e.g. high turnover rates.

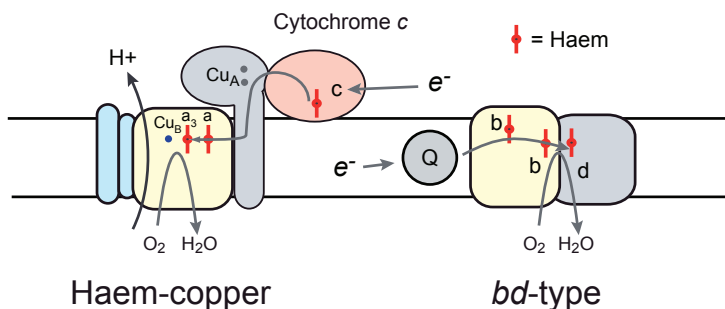

Figure 4 | Pictures of a haem-copper enzyme compared to a *bd*-type. The haem-copper enzyme has a binuclear centre containing Cu_B and a haem molecule while the *bd*-type enzyme probably uses two haem cofactors at the active site.

1.3 Anaerobic respiration

Many bacteria display respiratory flexibility and are able to use terminal electron acceptors other than oxygen (Table 1). One of the most common alternative electron acceptors for anaerobic respiration is nitrate, which may be used in dissimilatory nitrate reduction. This process is best understood in *E. coli* and *Paracoccus denitrificans*. [6, 29, 138]. In the simplest case the later part in the ETC previously described can be replaced by an anaerobic ditto. The principle of ATP-coupled oxidative phosphorylation is unchanged with the difference that nitrate is reduced to nitrite instead of oxygen to water in the reaction $\text{NO}_3^- + 2e^- + 2\text{H}^+ \rightarrow \text{NO}_2^- + \text{H}_2\text{O}$. The major dissimilatory nitrate reductase in *E. coli* is encoded by the *narGHJ* operon. In this system the electrons flow from the Q-pool (quinone pool) via a *b*-type cytochrome, NarI, and a complex iron-sulphur protein, NarH, to a molybdoprotein nitrate reductase, NarG [25].

The toxic nitrite (NO_2^-) produced, however, can be further reduced to ammonia, N_2O or denitrified altogether into gaseous nitrogen. One of the options used by *E. coli* is to reduce NO_2^- to NH_4^+ . Besides conserving energy, this process regenerates the all-important electron carrier NAD^+ .

Table 1 | Examples of electron acceptors used in respiration. Note the energetically favourable potential of $\text{O}_2/\text{H}_2\text{O}$ compared to other substrates.

	Electron acceptor	Reduced products	Reduction potential (V)	Example of microorganisms
Aerobic	O_2	H_2O	+0.82	Aerobic bacteria, fungi, protozoa and algae
Anaerobic	Fe^{3+}	Fe^{2+}	+0.77	<i>Pseudomonas</i> and <i>Bacillus</i>
	NO_3^-	NO_2^-	+0.43	Enteric bacteria and <i>Bacillus</i>
	NO_3^-	N_2	+0.74	<i>Pseudomonas</i> and <i>Bacillus</i>
	SO_4^{2-}	H_2S	-0.22	<i>Desulfovibrio</i> and <i>Desulfotomaculum</i>
	CO_2	CH_4	-0.24	All methanogens
	S^0	H_2S	-0.27	<i>Desulfomonas</i> and <i>Thermoproteus</i>



1.4 Fermentative metabolism

Fermentation is a general term for the anaerobic degradation of glucose or other organic nutrients to obtain energy conserved as ATP. Due to abundant availability and high amount of energy stored in D-glucose (at total combustion the free energy $\Delta G = -2840$ kJ/mol), the molecule is the major fuel for most bacteria. The Embden-Meyerhof-Parnas (glycolytic) pathway is the most common way for bacteria to dissimilate glucose. Glucose is not only used as a substrate for energy production but is also vital for anabolic reactions. Bacteria grow readily on carbon sources other than glucose but in such cases gluconeogenesis must be employed to generate glucose.

The glycolysis consists of two phases, one preparatory phase where glucose is converted to glyceraldehyde 3-phosphate (G3P) and one payoff phase where G3P is converted to pyruvate. In the preparatory phase, the cells invest 2 ATP and cleave the hexose chain into two three-carbon molecules of pyruvate. The payoff phase gains 4 ATP and 2 NADH so the net gain is 2 ATP and 2 NADH. The free energy change (ΔG) in the glycolysis reaction is only -146 kJ/mol, which means that ~95% of the total free energy is still left in the pyruvate. Much of this energy can be retrieved by oxidative phosphorylation and by the action of the Krebs cycle. However, if the oxidative phosphorylation is not active, e.g., when oxygen is not present and the organism cannot switch to any alternative electron acceptors, the cells face the problem of not being able to reoxidise NADH to NAD^+ . The glycolysis stalls at G3P and the cells will not be able to produce ATP by this process any longer. This is where anaerobic fermentation steps in. In this process, NAD^+ is regenerated to keep the glycolysis going.

There are species that are homofermenters that only ferment pyruvate to a single end product, e.g., *Lactococcus lactis* that produce lactate. The process involves reduction of one molecule of NADH to NAD^+ and energy is gained for an overall $\Delta G = -196$ kJ/mol for converting glucose to two molecules of lactate. However, many bacteria can ferment pyruvate using a mixed-acid fermentation, resulting in several fermentation end products. E.g. *E. coli* can ferment to ethanol and acetic, formic, lactic and succinic acids [111].

"Being a scientist means living on the borderline between your competence and your incompetence. If you always feel competent, you aren't doing your job."

Carlos Bustamante

Chapter 2 Redox regulation

In order to stay competitive in nature an organism needs not only good systems for energy conservation, anabolic and catabolic functions, but there is also a need for efficient regulation for when and why a system should be switched on or off. Since oxygen is the energetically most favourable electron acceptor, sensing and responding to oxygen is an important function in many bacteria. The regulatory mechanisms are just as important for switching off the anaerobic machinery since many of the fermentative enzymes are damaged by dioxygen [69]. Bacterial cells have developed sensors that relay changes in redox status into a changed expression level of enzymes needed for adaptation to the new conditions. There are several ways for a cell to respond to redox changes as will be outlined in this chapter.

2.1 Redox sensors involving iron-sulphur proteins

Iron-sulphur proteins often function as redox sensors. Fe-S proteins have been extensively studied because of their key roles in relaying electrons in the respiratory chain, photosynthesis and nitrogen fixation reactions. Iron-sulphur clusters (Figure 5) function not only as electron carriers but also as core elements in some well-described redox/oxygen sensors and transcription factors, some of which are discussed below.

All Fe-S clusters have a common architecture with the iron tetrahedrally coordinated. For Fe-S centres, the basic structural principle is the rhomb, which can be combined in a number of ways exemplified in Figure 5 [74].

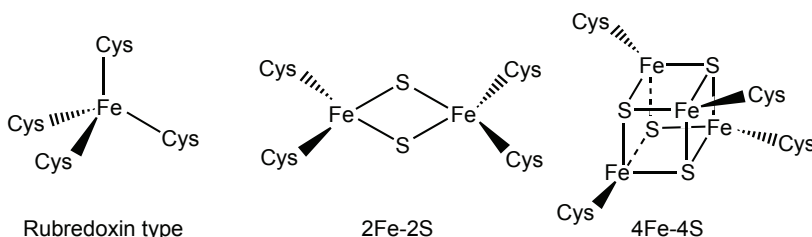

Figure 5 | Common iron-sulphur forms found in metal sites of proteins. The iron is always tetrahedrally coordinated by four sulphur atoms

A common principle that has emerged is that these clusters mediate responses to specific oxidants like oxygen or reactive species such as superoxide, and nitrogen compounds such as nitric oxide (NO^\cdot) and nitrosonium (NO^+) [74].

FNR (fumarate and nitrate reduction) is a regulator sensing oxygen via Fe-S clusters. The active form is a homodimeric protein containing one $[4\text{Fe-4S}]^{2+}$ cluster per subunit. The cluster is susceptible to attack by O_2 resulting in rapid and reversible conversion to a $[2\text{Fe-2S}]^{2+}$ [123] and finally to apoFNR upon exposure to high oxygen concentrations [2]. The oxygen dependent conversion of the Fe-S cluster inactivates FNR as a transcriptional regulator. (Figure 6). Nitric oxide is also able to by a nucleophilic attack perform the conversion of the Fe-S cluster. This reaction involves nitrosylation of the exposed iron and is likely performed by NO^\cdot (see chapter 3.2).

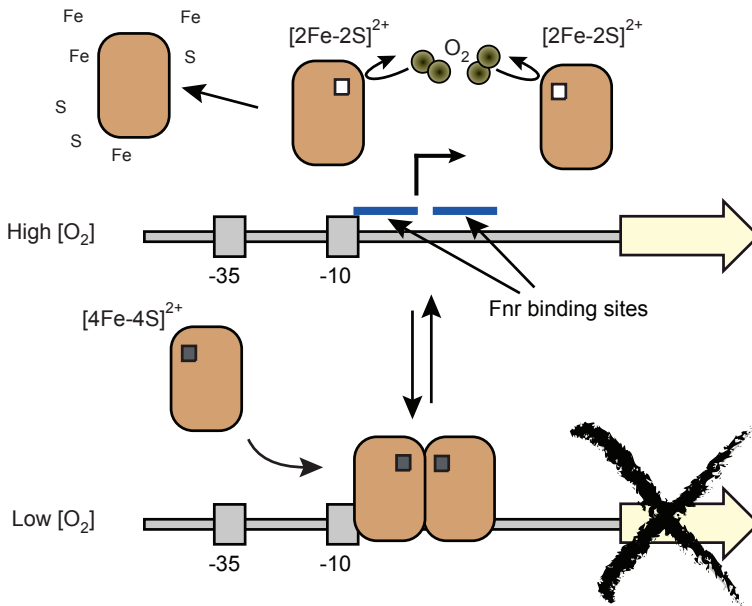

Figure 6 | Schematic picture of the action of FNR on a gene expressed at low oxygen tension. FNR exists as monomers when the Fe-S clusters are in the oxidised planar $[2\text{Fe-2S}]^{2+}$ form. Dimerisation occurs when the Fe-S centres become reduced to the cubic $[4\text{Fe-4S}]^{2+}$ conformation.

The dimerisation mechanism is not the only mode of action for the Fe-S centres. In other Fe-S centre based redox sensors the reduction of a $[2\text{Fe-2S}]^{2+}$ clusters to a $[2\text{Fe-2S}]^{1+}$ alters the DNA binding properties of the regulator (See SoxR in chapter 3.2).

2.2 Thiol based sensors

Phosphorylation of amino acid residues is a common theme in regulating the activity of proteins; common targets include serine, threonine, tyrosine, histidine and aspartate. Considering redox regulation, another amino acid is well suited for the task: Cysteine, where the sulphate-containing side-chain can assume different redox states, many of which are

reversible. Cysteine residues can be oxidised by both reactive oxygen species (ROS) and reactive nitrogen species (RNS).

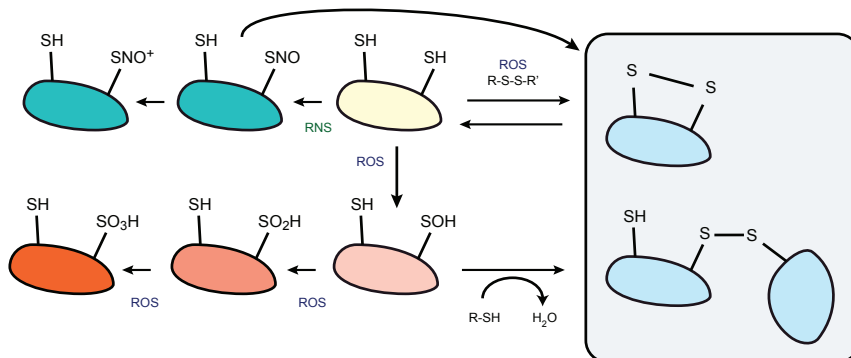

Figure 7 | The varying fates of cysteine in response to oxidative or nitrosative stress. The switch between the free thiols (-SH) and disulphide (-S-S-) is a reversible redox reaction mediated by either ROS or a thiol-disulphide exchange reaction in one direction and reductants such as thioredoxin in the reverse. The route to disulphide bond formation via sulphenic acid (-SOH) is non-reversible. ROS could also further oxidise the sulphenic acid, and this reaction renders the thiol groups permanently oxidised. The decay of S-nitrosothiol (-SNO) may lead to disulphide bond formation.

The thiol redox reactions can affect the activity of proteins in different ways. One of the best described bacterial systems is the σ^R activation in gram-positive actinomycetes, where the anti-sigma factor RsrA keeps σ^R inactive until RsrA's thiols are oxidised [71]. When adding H_2O_2 or the thiol-specific oxidant diamide, RsrA forms at least one internal disulphide bond and in the process releases an intrinsic zinc ion. The structural changes weakens the interactions between RsrA and σ^R . Finally, release of σ^R activates the regulon.

The *E. coli* OxyR transcription factor activates the expression of antioxidant defensive mechanisms. OxyR uses at least one of its six cysteine thiols as sensor for redox reactions. The formation of an internal disulphide bond by either a shift in redox status of the cell or attack by ROS mediates the signal for activation of OxyR [157, 159]. There is also an alternative model suggesting that the signal is not disulphide bridge formation, but rather nitrosylation of a single cysteine thiol from R-SH to R-SNO by RNS [76].

Not only disulphide bonds or nitrosylations can function as signals. In *B. subtilis* and in *Xanthomonas campestris* a single thiol group in the OhrR transcriptional repressor becomes oxidised to sulphenic acid. The oxidised protein can no longer bind DNA and the *ohrA* gene responsible for organic peroxide resistance, is activated [47].

2.3 Flavin-containing sensors

Flavoproteins are enzymes catalysing redox reactions using either FMN (flavin mononucleotide) or FAD (flavin adenine dinucleotide) as coenzymes (Figure 8). The fused isoalloxazine ring can be reduced by either one or two electrons transferred from a reduced substrate. The fully reduced forms are called $FADH_2$ and $FMNH_2$ and the partially reduced forms are the semiquinone radicals $FADH^\cdot$ and $FMNH^\cdot$. Since flavoproteins can accept or

release either one or two electrons, they are more versatile in the number of reactions they can participate in compared to enzymes working with pyridine nucleotides, which transfer two electrons. Flavin nucleotides are most commonly found bound as cofactors or prosthetic groups to their enzymes and do not transfer electrons by diffusing from one enzyme to the other; rather they provide a means by which the flavoproteins can temporarily hold electrons while the electron transfer from a reduced substrate to an electron acceptor is catalysed.

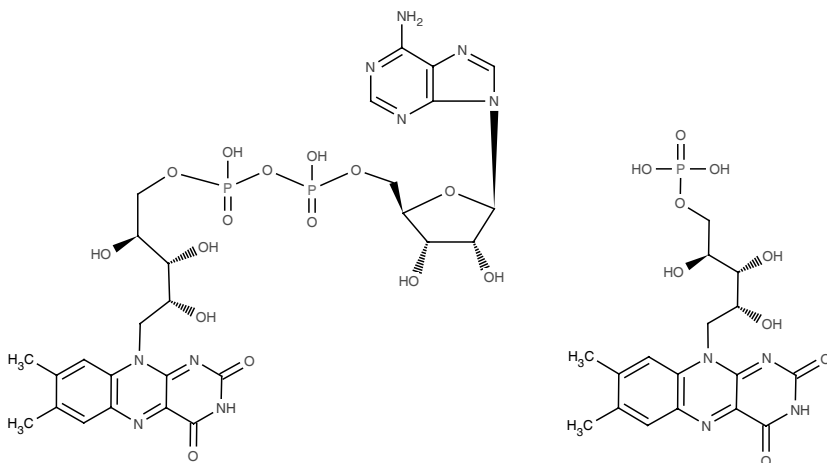

Figure 8 | The flavin molecules FAD (left) and FMN (right).

Diazotrophic bacteria have the ability to fix nitrogen, which gives them the ability to survive and proliferate in nitrogen-starved environments. The process does not come cheap; the nitrogen fixing enzyme nitrogenase consumes 16 mol of ATP per mol of dinitrogen fixed *in vitro*, and the energy cost increases to up to 40 mol of ATP per mol fixed nitrogen *in vivo* [91]. The nitrogenase is irreversibly inactivated by minute levels of oxygen, so sensitive and strict regulation is vital. The expression of the nitrogen fixation machinery in free-living diazotrophs is controlled by the alternative sigma factor σ^{54} . The expression of σ^{54} is in turn dependent on the enhancer-binding protein NifA. NifA in its turn is under redox control of NifL, an elaborate sensor integrating the signals for absence of fixed-nitrogen sources and a redox sensor for monitoring the oxygen levels [91]. The NifA-NifL system has been most thoroughly studied in *Azotobacter vinelandii* (aerobic bacterium) and *Klebsiella pneumoniae* (facultatively anaerobic). The NifA-NifL enzymes share a high similarity but exert their mechanisms by quite different routes. NifL senses the redox state by a prosthetic FAD moiety [62]. Oxidation of this group makes the NifL enzyme inhibit NifA expression while reduction of the FAD permits NifA expression. The two sensory inputs into NifL are mediated by discrete parts of the enzyme and the FAD sensing is dependent on an N-terminal PAS domain [62].

2.4 Haem

Haemes are redox active groups that are particularly versatile and suitable in redox and oxygen sensing. Haem is a porphyrin containing four substituted pyrrole rings joined by $-\text{CH}=\text{}$ bridges (Figure 9). The pyrrole rings provide four in-plane nitrogen groups that ligate iron. Haem is among other things used as a prosthetic group in proteins responsible for catalytical as



well as sensory functions. It has a central role in e.g. respiration (cytochromes), aerotaxis (HemAT) and detoxification (P450). The apoprotein provides one or two amino acid residues as axial ligands to the iron of the haem group. The haem molecule effectively binds small diatomic ligands such as O_2 , NO , CN^- and CO . Haem-based sensors are excellent for detection of these small ligands due to the ability of the protein to tune the sensitivity of the binding strength between the metal centre and the ligand. The interactions between the haem and the surrounding amino acids can change the affinity for O_2 by up to four orders of magnitude.

2.4.1 PAS domains

PAS domains are signalling domains that are widely distributed in proteins from all three domains of life. They function as input modules in proteins that sense oxygen, redox potential, light, and other stimuli. Structurally, the PAS domain is constructed by two conserved regions averaging only $\sim 12\%$ sequence identity, but the structural similarity is high [114, 158]. The domain spans ~ 130 aa and can associate with various cofactors. Functionally, the choice of cofactor is largely determined by the specificity of the protein, and the PAS domains has been coupled to a great number of environmental signals such as oxygen, ligands, light, voltage, xenobiotics and redox potential [142]. In redox and oxygen sensing the cofactors of choice are FAD and haem, respectively [55].

In *Sinorhizobium meliloti*, the process of controlling the oxygen sensitive nitrogenase is handled by the FixLJ two-component system. The PAS containing sensor FixL has haem as a cofactor. When oxygen binds to the haem-iron (at $pO_2 > 50 \mu M$) the oxy form of FixL first autophosphorylates a histidine in its own transmitter domain and subsequently relays the phosphate to a conserved aspartate in FixJ, the transcription factor, which becomes active. The mechanism of how O_2 binds and prevents the autophosphorylation of FixL is unclear. The prevailing hypothesis used to be that the spin state of the iron is the determining factor, since all the high-spin forms of FixL, including deoxy (Fe^{2+}), met (Fe^{3+}) and fluoromet ($Fe^{3+}F^-$), were active in the autophosphorylation reaction with ATP alone, whereas the low-spin forms, such as oxy ($Fe^{2+}O_2$), carbomonoxy ($Fe^{2+}CO$), cyanomet ($Fe^{2+}CN^-$) and imidazolmet ($Fe^{2+}Imid$), appeared to be inhibited [56]. It has been suggested that the *in vitro* reaction with ATP alone does not mimic the physiological reaction of FixL very well and recent studies have challenged the ideas of spin-state control since spectroscopically and at what is thought to be more physiological reactions, the equivalences of these spin-states have not been detected [144].

The direct oxygen sensor, Dos in *E. coli* and PDEA1 in *Acetobacter xylinum* are closely related to FixL from *S. meliloti* (Chapter 4.3), but the enzymatic module is very different. Here the exerted signal is a phosphodiesterase activity that in *A. xylinum* cleaves the second messenger 3',5'-cyclic diguanylic acid (c-di-GMP) to the linear dinucleotide pGpG [20]. The cyclic c-di-GMP but not the linear pGpG can activate the cellulose synthase 200-fold [126].

Each subunit in the tetrameric Dos contains two PAS domains where the binding of oxygen to one of the domains has been suggested to trigger a displacement of a histidine at a hexacoordinated haem and thereby change the phosphodiesterase activity with cAMP of the other PAS domain [35]. Structural studies on the sensory domain confirms sizable ligand-dependent conformational changes depending on whether O_2 is bound or the haem is coordinated by an internal methionine [115].

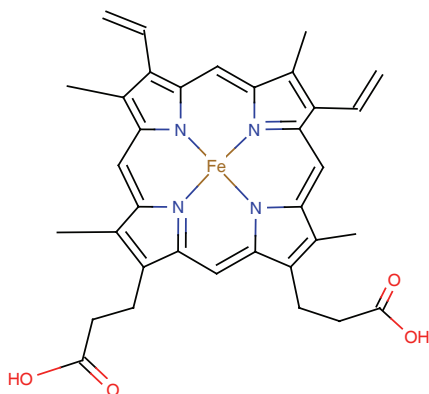

Figure 9 | The structure of haem b. The iron is coordinated by four nitrogen atoms provided by the pyrrole rings.

2.4.2 Globin-coupled sensors

This group of sensors has a classical globin fold as opposed to the PAS domain fold of the above described proteins. Haem as a direct oxygen sensor has best been described in the soluble aerotactic signal protein HemAT [64, 65], where oxygen binds haem in its ferrous (Fe^{2+}) state. The binding of O_2 presumably triggers a conformational change where the altered state signals through the chemotactic machinery to direct the rotational direction of the flagella. The crystallised forms of HemAT in unliganded (Fe^{2+}) and cyanomet ($\text{Fe}^{2+}\text{CN}^-$), are nearly identical dimers and the mechanism of the sensory function is unknown. It has been suggested that the *in vivo* form of HemAT is homotetrameric rather than dimeric as in the crystals [54].

2.5 Q-pool

A central component of the ETC is the Q-pool (quinones + quinols), which acts as a redox mediator and shuffles electrons from dehydrogenases towards the terminal oxidases. By sensing the relative fractions of quinone and quinol present in the Q-pool, the redox status of the cell can be monitored. This is also a way for aerobic bacteria to indirectly sense the oxygen state, since the Q-pool will shift towards a more reduced state when the terminal oxidases run out of substrate to reduce and thereby stall the ETC [112].

The best characterised system for sensing the redox status of the quinol pool is the ArcAB system of *E. coli*. This represents a classic response-regulator system but with some interesting differences. At the transition from aerobic to microaerophilic and anaerobic conditions the ArcB sensor kinase autophosphorylates and subsequently transfers the phosphate to the response regulator ArcA (Figure 10). ArcA is a classical two-component regulator that, when phosphorylated, binds DNA [80].

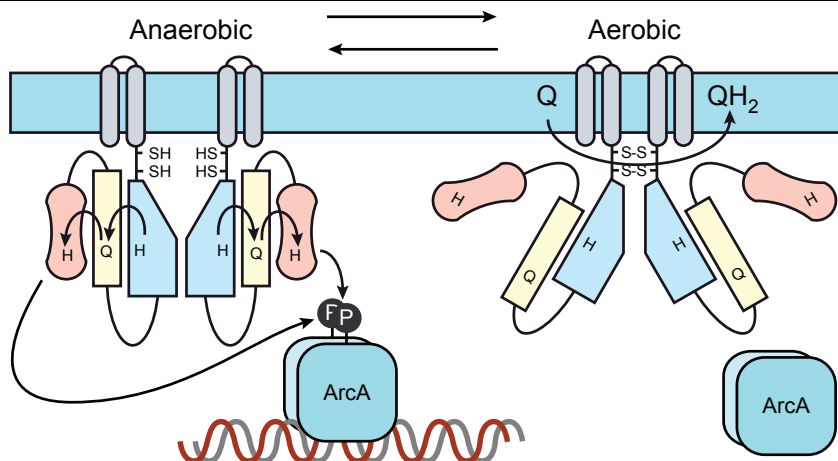

Figure 10 | The ArcAB regulatory mechanism. In the anaerobic state the cysteines of ArcB are reduced and the internal phosphorelay is active and transfers a phosphor group (P) to ArcA, which becomes activated. Under aerobic conditions oxidised quinone forms the disulphide bridges between two subunits of ArcB and thereby disrupts the phosphorelay.

ArcB is anchored to the membrane by two transmembrane α -helices which are interspersed by a short periplasmic region of only 16 aa. The periplasmic region contains no amino acids active in sensing, hinting that the sensor does not monitor external signals [80]. The cytosolic domain of ArcB is elaborate and contains a tripartite hybrid kinase, i.e. there are three internal catalytical domains; an N-terminal receiver, a central transmitter and a C-terminal phosphotransfer domain. This arrangement creates an internal phosphorelay before transferring the phosphate to ArcA [52]. Malpica *et al.* showed that the kinase activity of ArcB is switched on in the presence of DTT or 2-mercaptoethanol, pointing out the importance of disulphide bonds. The active cysteines are in a linker region of ArcB and give rise to a dimerisation of ArcB, which thereby silences the kinase activity [87]. The oxidation of the cysteines is exclusively dependent on the action of oxidised quinones of the ETC, neither molecular O_2 nor H_2O_2 has any effect on the redox state of the cysteines.

2.6 Pyridine nucleotides

Nicotinamide adenine dinucleotide (NAD^+) and its relative nicotinamide adenine dinucleotide phosphate (NADP) are ubiquitous coenzymes in cellular redox reactions and therefore obvious candidates for redox sensing. One of the primary functions of the NAD^+ / $NADH$ redox pair is to transmit electronic charge in the ETC, but NAD^+ / $NADH$ also frequently occur as cofactors bound to proteins. From a sensory perspective, the bound forms are of minor interest compared to the free pool since the redox status of bound NAD^+ / $NADH$ does not necessarily depend on the cellular redox status. The pool of free NAD^+ / $NADH$ on the other hand is quite small, has a high turn over and is directly affected by the cytosolic redox status. This means that the redox poise of the free pool will reflect the overall cellular status.

In eukaryotic cells the transcriptional co-repressor CtBP (carboxyl-terminal binding protein) is involved in repressing pathways important for development and cell cycle regulation. This is

performed via CtBP binding to regulatory proteins, and preventing their DNA-binding functions. The protein-binding activity of CtBP has been shown to be regulated by the intracellular NAD^+/NADH ratio, and activation of CtBP has been shown to occur *in vitro* at NADH levels as low as ~ 10 nM (see discussion of free levels of NAD^+/NADH further ahead) [155].

CtBP must be able to discern between NAD^+ and NADH based on the single hydrogen atom difference. This idea has been met with some doubt and it assumes that the binding affinity (K_d) for NADH is higher than the corresponding value for NAD^+ . Experimental evidence using FRET and competition shows that this indeed is the case for CtBP and this speaks in favour of the sensory function [44]. Based on crystallographic studies, the NADH-dependent dimerisation of CtBP has been suggested to be the mechanism of activation [109]. A high affinity of CtBP for NADH has been established, but the levels of free NADH required must be within physiological limits. By two-photon microscopy Zhang and co-workers determined the eukaryotic level of free NADH to be ~ 100 nM, well within the range required for stimulating CtBP interaction [155].

Sensing the NAD^+/NADH poise is not exclusive to eukaryotes. The Rex protein in *Streptomyces coelicolor* changes its DNA binding behaviour when faced with increasing concentrations of NADH (Figure 11). The IC_{50} (inhibitory concentration) for loss of Rex DNA-binding activity is ~ 5 μM NADH at 0.25 mM NAD^+ (I.e. at $\sim 2\%$ NADH compared to the total NAD(H) pool). Structural studies have shown that a Rex homologue from *Thermus aquaticus* exists as a dimer when NADH is bound, and conformational changes are thought to diminish the DNA binding capacity in the NADH-bound state [134].

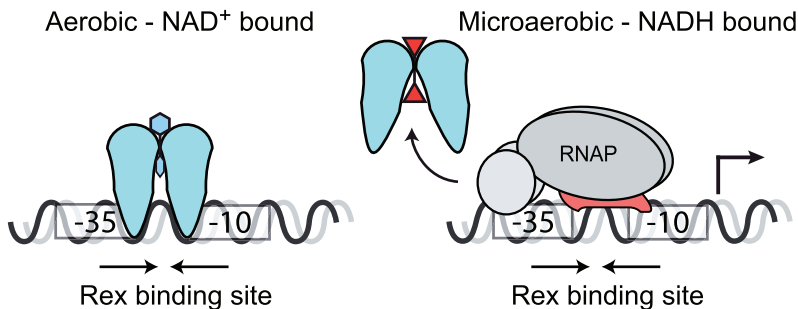

Figure 11 | The regulatory mechanism of Rex. Rex binds both NAD^+ and NADH but when the NAD^+/NADH ratio falls the higher affinity for NADH and subsequent conformational changes makes the protein lose its DNA binding capacity.

Not only NAD(H) is used as a redox reporter but also NADPH. CbbR, which is a regulator of the LysR family in *Xanthobacter flavus*, controls expression of proteins necessary for autotrophic fixation of CO_2 . CbbR binds to three sites located inside or in close proximity to promoter regions and the strength of binding to the motifs is increased threefold by NADPH with an apparent K_d of 75 μM [146]. Whether this corresponds to physiological concentrations is doubtful. The mechanism includes a change in the bending angle for the DNA depending on whether NADPH is present or not. The presence of NADPH was shown to relax the bending of promoter DNA, which is a common theme of regulation in prokaryotes [118].



“Basic research is what I am doing when I don't know what I am doing.”
Werner von Braun

Chapter 3 Stress responses

3.1 Oxidative stress

The oxygenation of the atmosphere that started with the proto-cyanobacteria reshaped the world from a primarily reductive place into the oxidative breathable space we are experiencing today. This pushed forward the evolution of efficient oxidative respiration but also the need for prevention and handling of the damage induced by reactive oxygen species (ROS).

Redox enzymes are notoriously non-specific, transferring electrons to any good acceptor which they make electronic contact with. This becomes a problem with freely diffusible oxygen which –with the exception of highly protected internal sites of proteins– can access almost any part of the cell. ROS are formed by accident when O_2 adventitiously oxidises redox enzymes that are designed to transfer electrons to other substrates. The most commonly considered ROS are: superoxide (O_2^-), hydrogen peroxide (H_2O_2), and the hydroxyl radical (HO^\cdot). These efficiently oxidise and often irreversibly damage proteins, nucleic acids and lipids [46, 72].

Enzymes containing iron-sulphur clusters have been shown to be susceptible to superoxide attack on the [4Fe-4S] clusters by O_2^- . Superoxide removes the catalytic iron atom resulting in a dysfunctional [3Fe-4S] cluster [45, 49]. Superoxide is quite specific in what enzymes it can damage, e.g. the Fe-S clusters in the respiratory enzymes cannot be damaged by O_2^- . Superoxide also inhibits the synthesis of branched-chain, aromatic and sulphurous amino acids [19, 42].

H_2O_2 oxidises protein cysteinyl residues, creating sulphenic acid compounds that can form disulphide bridges or be further reduced to sulphinic or sulphonic acid (Figure 7). Peroxide can also be involved in formation of carbonyls with a variety of amino acids [136], most probably via Fenton chemistry. The effector molecule in peroxide reactions seems to be the hydroxyl radical HO^\cdot . The Haber-Weiss reaction, which makes use of Fenton chemistry, is the major mechanism by which the highly reactive hydroxyl radical is generated in biological systems [72]. The Haber-Weiss reaction depicted below occurs between H_2O_2 and free iron, i.e. iron not incorporated into enzymes or iron-storage proteins. The relevant reactions here are: $Fe^{3+} + O_2^- \rightarrow Fe^{2+} + O_2$ and a second reaction creating the hydroxyl radical: $Fe^{2+} + H_2O_2 \rightarrow Fe^{3+} + OH^- + HO^\cdot$

HO^\cdot is one of the most reactive compounds found in the cell. It reacts with most cell constituents at virtually diffusion rates. It is likely that some of the toxic effects exerted by superoxide is due to secondary formation of the hydroxyl radical. Indicative of this is that bacteria commonly

respond to peroxide stress by producing Dps, a ferritin-like protein. Dps sequesters DNA into extremely stable biocrystals which effectively protect the DNA against various assaults [151] and also scavenger iron ions and thereby eliminate some of the HO[•] formed in Fenton reactions [156].

It is well known that high concentrations of molecular oxygen are toxic to cells [58] but the general assumption is that O₂ does not play a major role compared to ROS. Flint et al. demonstrated that O₂ could damage [4Fe-4S] clusters of several dehydratases with the same efficiency as O₂⁻ [46]. The similar damage rates might be coincidental but it might also be possible that cells have evolutionary built up a defence against superoxide only to the point at where O₂ becomes the major threat to their iron-sulphur clusters.

3.2 Nitrosative stress

The chemistry of NO[•] in biological systems is extensive and complex. There can be direct effects, which are reactions fast enough to occur between NO[•] and specific biological molecules. In many cases, these can be beneficial effects. In vertebrates, NO[•] is responsible for smooth muscle relaxation, platelet inhibition, neurotransmission and immune regulation [17].

At micromolar concentration NO[•] together with O₂ or O₂⁻ results in ROS and RNS production. These reactive species cause cellular damage to a variety of biomolecules such as inactivation of enzymes containing haem and disruption of Fe-S clusters [66, 148]. In the perspective of a pathogenic organism a big threat is macrophages which release large amounts of NO[•] via inducible nitric oxide synthases (iNOS) [41, 110]. For the human fungal pathogen *Cryptococcus neoformans* two enzymes that can denitrify NO-related molecules are important for its virulence [34]. *Pseudomonas aeruginosa* in its virulent mucoid forms is a common pathogen in patients suffering from cystic fibrosis. This variant has a high constitutive expression of defence mechanisms against NO[•] which might protect the bacteria from the host's immune response [43].

NO[•] is a lipophilic free radical but by itself remarkably unreactive towards biological tissues. NO[•] is readily soluble in water but does not react with it. NO[•] reacts directly with O₂ but only at a slow rate. The half-life of the radical could be up to 30 minutes assuming oxidation to NO₂. Inside cells on the other hand, the half-life is assumed to be quite short, down to the order of seconds due to reactions with superoxide, haem and Fe-S [122, 137].

Nitric oxide form complexes with transition metal ions such as iron and copper including ions bound into metalloproteins. NO[•] can in contrast to O₂ bind to Fe(III) porphyrins. Charge is relocated within the Fe(III)NO[•] and the resulting complex is Fe(II)NO⁺. A nucleophilic attack frees the nitrosonium from the ferrous iron and the nitrosonium can then readily perform nucleophilic attacks on e.g. ribonucleotide bases and aromatic compounds [137]. Nitrosonium ions form a variety of nitroso-compounds and these could be considered as NO⁺ carriers. These compounds include hyponitrites (RS-NO), nitrosamines (RNH-NO), alkyl and aryl nitrites (RO-NO) and dinitrogen (N₂O₃, N₂O₄). This variety of nitroso-compounds with different physiological properties result in many different nitrosylation reactions.

Despite the obvious importance of NO[•] and its derivatives, the knowledge of how RNS affect proteins in bacteria is sparse compared to what we know about interactions with oxygen and its

derivatives. The regulators SoxR, OxyR (chapter 2.2) and flavohaemoglobins are notable exceptions.

The transcription factor SoxR in *E. coli* is activated upon oxidation of the redox active [2Fe-2S] clusters to [2Fe-2S]²⁺ by O₂^{·-} but can also be activated by NO[·] causing the [2Fe-2S] centres to form protein-bound dinitrosyl-iron-dithiol adducts [36]. Activated SoxR stimulate the expression of another transcription factor, SoxS, which in turn activates ~45 genes encoding proteins responsible for removing ROS and involved in repair of the specific types of oxidative and nitrosative damage that may have occurred during the stress [8, 74].

The best characterised globin involved in handling NO[·] is the flavohaemoglobin (encoded by *hmp*) from *E. coli* [120]. The primary, and indeed the only showed function of Hmp is NO[·] detoxification. Hmp has two functional domains, a globin domain which can bind O₂ or NO[·] and a flavin domain containing a FAD molecule. The FAD domain transfers electrons one by one from NAD(P)H to the active site in the haem. Hmp detoxifies NO[·] to NO₃⁻ while consuming O₂ and NAD(P)H [48].

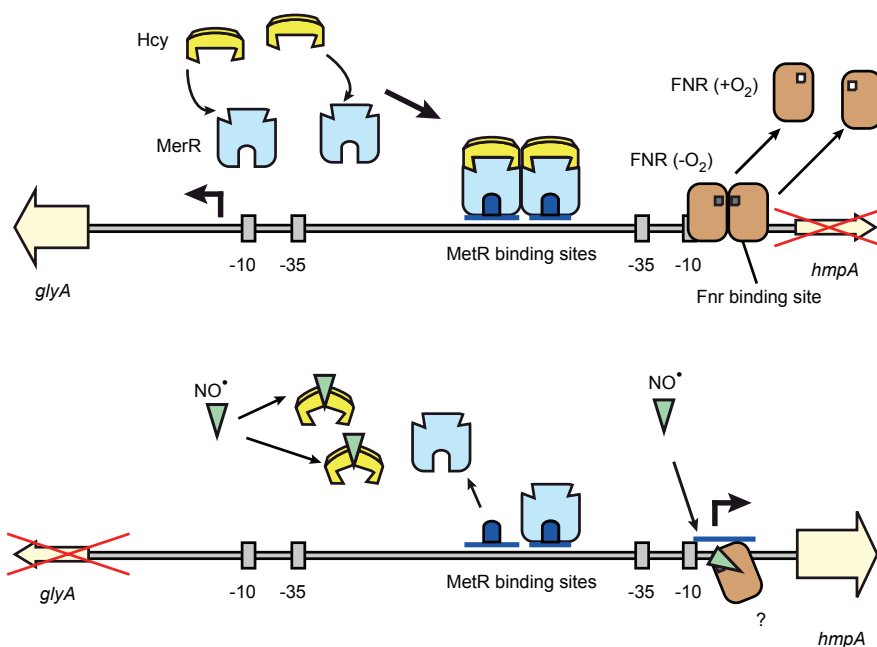

Figure 12 | The regulation of *hmp* by NO[·]. At low NO concentrations, top picture, the binding of Hcy to MerR directs the DNA binding capacity of MerR to two sites between the *glyA* and *hmp* genes and FNR binds as a dimer to sites in the FNR promoter. At higher levels of NO[·] (bottom picture), NO[·] binds to Hcy and this destabilises the Hcy-MerR binding. MerR without Hcy has a decreased affinity for DNA but still binds to the site closest to the *hmp* promoter. In this situation MerR acts as an activator for *hmp* transcription. The iron Fe-S clusters in FNR is also attacked by NO[·], resulting in decreased affinity. However, FNR still seems to bind partially to its recognition site and this is thought to attenuate the expression levels of *hmp*. Model as suggested by Membrillo-Hernandez et al [94].

The expression of *hmp* is induced by NO[·], SNP and the NO[·]-releasing compound GSNO. As opposed to NO[·] and GSNO, SNP is primarily a nitrosating agent (see below). Interestingly, the induction by GSNO is an effect of a nitrosation of the homocysteine Hcy [94]. The nitrosation



deprives the regulator MetR of its co-regulator Hcy. MetR-Hcy is a positive regulator for the *glyA* gene which in turn has a promoter divergently overlapping the promoter of *hmp*. MerR alone binds to a site proximal to the *hmp* promoter and thereby induces the transcription of *hmp* (Figure 12) [94]. The NO[•]-dependent expression of *hmp* is negatively affected by the anaerobic regulator FNR (chapter 2.1). The [4Fe-4S] clusters in the enzyme can be inactivated by NO[•] as well as O₂, an inactivation that decreases the proteins affinity for the recognition site in the *hmp* promoter (Figure 12) [121].

The truncated haemoglobins (chapter 2.4) have also been suggested to be involved in protection against NO[•]. The truncated haemoglobin from *Mycobacterium tuberculosis* has been shown to efficiently convert NO[•] to NO₃⁻ when heterologously expressed in *Mycobacterium smegmatis* and *E. coli* [95, 113]. Theoretical models support a mechanism where NO[•] reacts with O₂ coordinated to the haem moiety [30].

In **Paper II**, where we research the nitrosative stress of *B. subtilis*, we have used sodium nitroprusside (SNP) –a hypotensive agent used clinically in cardiac emergencies– to induce nitrosative stress in the cells. The SNP anion [Fe(CN)₅(NO₂)]²⁻, contains an NO⁺ group which can be released and function as an effective nitrosating agent. SNP is often declared to be a releaser of NO[•] via hydrolysis of the anion and subsequent release of NO[•] [61, 78]. Indeed, if SNP is exposed to light in vitro, photolytic decomposition generates NO[•] in equimolar amounts by hydrolysis of the anion [3]. However the general belief at the present time is that NO[•] could be produced, but mainly as a secondary reaction via nitrosation of a thiolate group with a subsequent decomposition and release of NO[•] and the oxidised thiol RS [120]. The primary action by SNP in microorganism is likely to be exerted by nitrosation via NO⁺.



“Every man gets a narrower and narrower field of knowledge in which he must be an expert in order to compete with other people. The specialist knows more and more about less and less and finally knows everything about nothing.”

Konrad Lorenz

Chapter 4 Redox sensing in gram-negative bacteria

Here follows a presentation of some of the best characterised redox sensing systems in gram-negative bacteria.

4.1 γ -proteobacteria – *E. coli*

E. coli – the whipping boy of microbiology and genetics labs around the world, is by far the best characterised organism in the world. Named after Theodor Escherich, who did pioneering work on intestinal bacteria at the turn of the last century. It is one of the most common bacteria in the lower intestines of warm-blooded animals, including birds and mammals. But *E. coli* is not only a vitamin producing commensal, there are several pathogenic strains, like the infamous *E. coli* O157 which causes hemorrhagic colitis.

In *E. coli* there are several well described systems responsible for sensing and regulating the transcription levels of genes in response to redox change and a variety of stress conditions. In this section I will present three systems involved in oxygen and redox sensing.

4.1.1 FNR

FNR, a Fe-S protein that acts as an oxygen-responsive transcription regulator (see chapter 2.1), was initially identified in mutants that failed to carry out fumarate and nitrate reduction, hence the FNR designation [82]. Since then FNR has been demonstrated to control a number of genes involved in adaptation to low oxygen conditions. In particular FNR regulates genes involved in energy production by oxidative phosphorylation. Affected induced functions include nitrate respiration (*narG* operon), and Krebs cycle genes encoding fumarase and isocitrate dehydrogenase [9, 21]. FNR also acts as an repressor of genes involved in aerobic respiration such as cytochrome *bd* and cytochrome *bo* [27].



Microarray studies comparing *E. coli* cultivated aerobically with anaerobically cultured cells show that over one third of the transcriptome is affected when *E. coli* is transferred from aerobic to anaerobic conditions. Up to half of these genes are directly or indirectly regulated by the global sensor-regulator FNR. That accounts for an astonishing 712 genes affected by FNR alone [128]. The number of genes earlier reported to be associated with FNR is more modest, ~70 [86], >100 [123], up to 125 [73] and 159 [127].

It should be noted that in the studies by Salmon et al. [128] the final results of steady state growth with or without oxygen are compared, and without doubt most of the regulated transcripts are effects not directly associated with FNR. Genes transiently affected by sudden changes in oxygen availability might not even show up here at all, and this approach is quite different from the one we have taken in our studies [83], where we measured the first wave of response to a rapid change in pO_2 . One thing is clear though, and that is that an anaerobic environment confers a vastly changed gene expression in *E. coli*.

4.1.2 ArcAB

The ArcAB system responds to the accumulation of reduced quinone in the membrane by dimerisation upon formation of disulphide bonds [4, 8, 51] (discussed in chapter 2.5). The scope of regulation includes aerobic and anaerobic respiratory and fermentative pathways.

Microarray studies indicated that 1139 genes are regulated, directly or indirectly by ArcA [129]. According to more sane estimates, ~20 [86] to ~100 [84] operons are regulated by ArcAB. While FNR responds mostly to strict anaerobic conditions ArcAB is induced by microaerobic conditions rather than total anaerobiosis [4]. There is a considerable overlap of genes modulated by these regulators [86, 117]. The overlap allows for a sensitive but robust transcriptional response over a wide range of oxygen concentrations. It should also be recognised that the redox signals influence each other. Oxygen availability (sensed by FNR) modulates electron flow along the aerobic electron transport chain (sensed by ArcAB).

Of particular interest is the control ArcA has over the quinone oxidases of *E. coli*. Low oxygen levels favour the expression of the high oxygen affinity cytochrome *bd* (*cydAB*) while these conditions repress the low affinity cytochrome *bo* (*cyoABCDE*) [26, 125]. The *cyoABCDE* operon is maximally expressed at ~20% air saturation or above while at this level *cydAB* is expressed only at a basal level. At microaerobic conditions (~7% air saturation) *cydAB* is expressed maximally and the expression of *cyoABCDE* is declining. At anaerobic conditions, *cydAB* is expressed at ~40% while *cyoABCDE* expression is minimal [143]. Both operons have been shown to be regulated by ArcAB [28, 68] and FNR [26]. Upon microaerobic conditions, ArcA represses *cyoABCDE* while at the same time activating *cydAB*, thereby facilitating growth (Chapter 1.2). At anaerobic growth there is an overlap of sensory functions when ArcA represses only *cyoABCDE* and FNR represses expression of both cytochromes.

4.1.3 Dos

In *E. coli* exists a third suggested oxygen sensor, Dos (Direct oxygen sensor), a PAS containing enzyme with phosphodiesterase activity (chapter 2.4.1). The possibility that Dos senses some



other diatomic gas, in particular CO or NO, can be ruled out by the low binding strength, $K_d \sim 10 \mu\text{M}$ for both molecules. This makes Dos essentially blind for these molecules at physiological concentrations. The K_d for oxygen is also $\sim 10 \mu\text{M}$, but this on the other hand is in the range of physiological microaerobic to aerobic conditions [35].

A homologue of Dos with a characterised function exists in the gram-negative bacterium *A. xylinum*. The bacterium forms a cellulose pellicle at high oxygen levels and this formation is facilitated by an allosteric activator, c-di-GMP. When oxygen gets scarce the Dos homologue PDEA1 hydrolyses c-di-GMP to pGpG and cellulose production is inhibited [20]. The PDE activity towards cAMP suggested the function as a redox sensor [131] but the fact that it is easy to reduce ($E^0 = +67 \text{ mV}$) makes this function debatable [55].

Does *E. coli* need another oxygen sensor? Dos does not function as a transcriptional regulator like ArcAB and FNR and the additional regulatory possibilities of affecting systems by PDE might prove useful. So far no products have been assigned to be exclusively regulated by Dos and the physiological function is uncertain. Dos has been suggested to be a controller of biofilm formation, cAMP regulation and being a redox sensor [55, 131].

4.2 α -proteobacteria – *R. sphaeroides*

The bacterium *Rhodobacter sphaeroides* belongs to the phototropic group of the α -3 proteobacteria. The bacteria in this group are among the most metabolically diverse organisms known, being capable of growing under a wide variety of conditions. For example, *R. sphaeroides* possesses an extensive range of energy-acquiring mechanisms including photosynthesis, lithotrophy, aerobic and anaerobic respiration. It can also fix N_2 , synthesize important tetrapyrroles, chlorophylls, haem, and vitamin B12. In order not to make researchers disappointed, the elaborate metabolic system is accompanied by an equally elaborate regulatory system. Here I will focus on two unique features; the integrated sensing of redox and light status by a single protein and the redox sensory function of a terminal oxidase.

The oxygen-dependent regulation of photosynthesis (PS) genes in *Rhodobacter* has been extensively studied [14, 75, 112, 141] and it was early noticed that the regulation was dependent on light intensities [23]. The blue-light sensor was eventually found and identified as PpsR in the AppA-PpsR antirepressor-repressor system [57]. The major oxygen sensory system is a two-component system PrrA/PrrB which confers an overlying layer of redox control to most of the cell's energetic machinery such as photosynthesis, carbon fixation, nitrogen fixation, hydrogen oxidation, denitrification, aerobic and anaerobic respiration, electron transport and aerotaxis [38].

To conserve energy *R. sphaeroides* utilises oxidative phosphorylation when growing aerobically and can switch to alternative electron receptors such as DMSO or TMAO anaerobically [98]. When growing anaerobically with light present *R. sphaeroides* switches to use photosynthesis. The reason for not using photosynthesis under aerobic conditions is the formation of extremely reactive species such as singlet oxygen ($^1\text{O}_2$) by energy transfer from excited triplet-state chlorophyll pigments to O_2 [77].

R. sphaeroides uses a novel sensory mechanism to detect the oxidative state of the electron transport chain [112]. The haem-copper type terminal oxidase *cbb*₃ contains a specialised

subunit (CooQ) that senses the electron flux through the enzyme. When the flux of electrons is high through *cbb₃*, CooQ signals to PrrB to autophosphorylate and PrrB subsequently transfers the phosphor group to PrrA. Phosphorylated PrrA activates transcription of the regulon mentioned above [112].

The other highly interesting sensor is the enzyme AppA, which is a sensor for both blue light and redox state [14]. The redox state is suggested to be sensed via the Q-pool [57, 112] but the mechanism is still elusive. The mechanism of light-sensing is achieved through a novel type of FAD-binding domain designated BLUF [60]. AppA is an antirepressor of the PpsR transcriptional regulator, which, when active, binds and represses the PS genes. These two sensory inputs are obviously not enough, since investigations have pointed out a third regulatory layer on AppA. When cellular redox status is oxidative, an internal disulphide bond forms in both PpsR and AppA, and the oxidised form of PpsR has an increased affinity for its DNA targets [92].

Just to top it off, there is an FNR homologue, FnrL, which also regulates PS genes in response to molecular oxygen [153]. Surely, not even the most passionate researcher can be disappointed in the daedal regulation of this system!

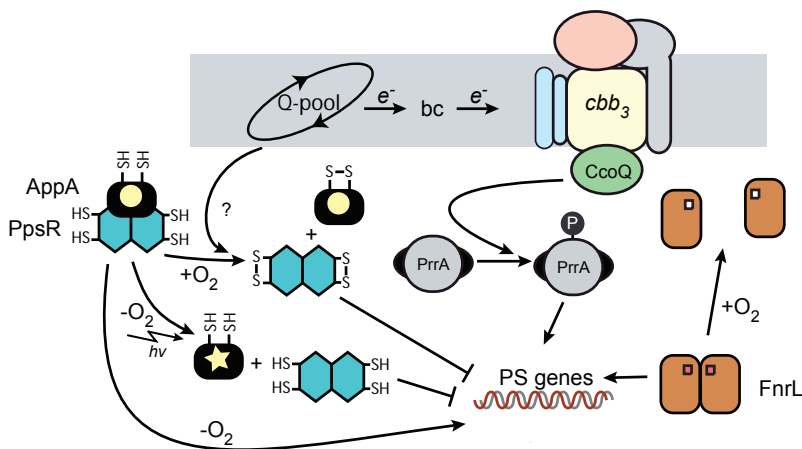

Figure 13 | The regulatory control of photosynthetic genes in *R. sphaeroides*. The system integrates sensory information from redox state (CooQ and Q-pool), molecular oxygen (AppA, FnrL), thiol chemistry (AppA, PpsR) and light (AppA).

4.3 α -proteobacteria – *B. japonicum*, *S. meliloti*

The best-characterised PAS proteins in the bacterial domain are the oxygen responding FixLJ proteins of *S. meliloti* (FixLJ-sm) and *Bradyrhizobium japonicum* (FixLJ-bj). These organisms are gram-negative, rod-shaped, nitrogen-fixing bacteria and develop a symbiosis with the alfalfa and soybean plants, respectively. In conjunction with the plant the bacterium develops root nodules which are highly specialised structures with a physical barrier to keep the free oxygen level low. The plant cells within the nodule produce leghaemoglobin, which serves as an oxygen carrier to the bacteria within the nodule. This enables the bacteria to obtain enough oxygen for respiration but ensures that the oxygen is in a harmless bound form since free O_2 prevents

nitrogen fixation. The organisms fix N_2 to NO_3^- as a payment for room and food to the host. This is where oxygen is critical. The central nitrogenase in the fixation reaction is rapidly and irreversibly inactivated by oxygen, and therefore it is necessary to keep a tight control over the expression of the genes involved in N_2 fixation. The sensor mechanism of the FixL PAS-haem domain for *S. meliloti* is described in chapter 2.4.1.

The phosphorylation of FixL in *B. japonicum* is somewhat different from *S. meliloti*: here FixL forms a complex with FixJ and ATP. FixL without bound oxygen (inactive state) catalyses the transfer of an ATP- γ -phosphoryl group to FixJ. The binding of O_2 to FixL switches off the kinase activity and dissociation of O_2 from haem fully restores the activity [55].

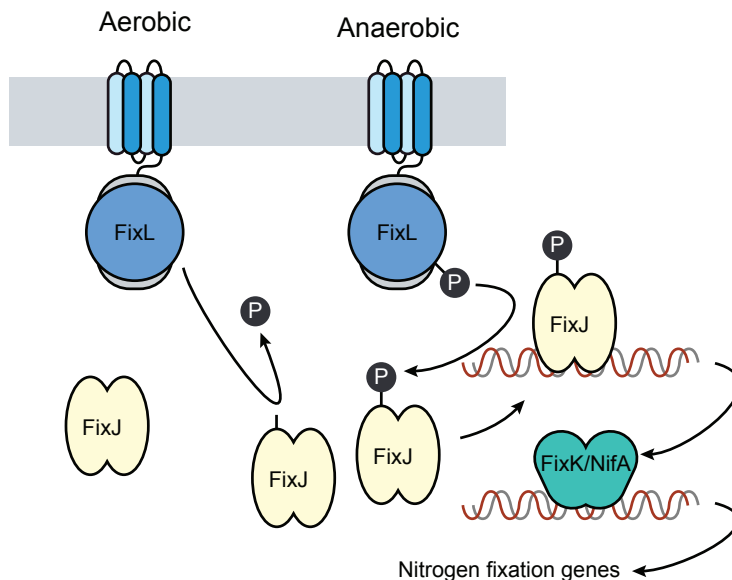

Figure 14 | The regulation of nitrogen fixation genes in *S. meliloti*. FixL autophosphorylates at low oxygen levels and subsequently activates FixJ by relaying the phosphate (P). Aerobic FixL has a phosphatase activity that ensures the dephosphorylation of FixJ.

In *R. meliloti*, phosphorylated FixJ activates expression of the transcription factors FixK and NifA, which subsequently activate genes required for nitrogenase expression. A similar control occurs in *B. japonicum* in which phosphorylated FixJ activates anaerobic expression of FixK2, which in turn activates expression of the alternative sigma factor, σ^{54} . σ^{54} is finally used to initiate nitrogenase expression. Consequently, FixL/FixJ play a central role in regulating gene expression of nitrogen fixation genes in response to a reduction in oxygen tension in these species [8].

The oxygen-dependent step is the autophosphorylation of FixL rather than the phosphorelay from FixL to FixJ. FixL also has the ability to control the phosphorylation status of FixJ by acting as a phosphatase of FixJ-P. Interestingly, both FixL and FixL-P have about the same phosphatase activity at aerobic conditions, but the phosphatase activity of FixL-P is absent at anaerobiosis. The anaerobic conditions would therefore favour the kinase activity at the same time as the phosphatase activity is suppressed [85].



“There ain’t no rules around here! We’re trying to accomplish something!”
Thomas Alva Edison

Chapter 5 Redox regulation and stress responses in *B. subtilis*

Soak some hay in water, put the infusion in a flask, boil for some minutes and wait. That’s a nineteenth century recipe for creating life. Or at least so thought scientists like Félix Archimède Pouchet and Henry Charlton Bastian who were active in trying to prove the theories of spontaneous generation of life to be true [139]. They were wrong. What they really were unknowingly discovering was the heat-resistant endospores of gram-positive bacteria such as *B. subtilis*.

The scientist who finally described and discovered the truth about *B. subtilis* in 1873 was Ferdinand Cohn. He described the physiology including the sporulation cycle and systemised the *Bacillaceae* family [24]. Cohn, as a plant physiologist, put bacteria in the category of infectious unicellular plants, so he was not correct on all points either. For an interesting review of the early days of microbiology see [37].

The use of *Bacillus* as a research organism traces back to Lois Pasteur, who developed a vaccine against anthrax by using heat-attenuated *Bacillus anthracis* bacteria. The interest in the gram-positive bacteria gradually shifted from studies of pathogenicity to industrial applications, where *Bacillus* strains are economically valuable organisms used for production of, among other things, vitamins, antibiotics and proteases. The interest shifted once again, and this time towards basic research when Burkholder and Giles [18] used *B. subtilis* for early genetic work with auxotrophs. One of the real breakthroughs came when Spizizen and Anagnostopoulos [5, 135] demonstrated that *B. subtilis* was naturally competent in uptake of free DNA from the surrounding medium. The uncomplicated genetic work coupled with interesting capabilities such as the sporulation lifecycle made *B. subtilis* a favoured organism for researchers studying gram-positive bacteria. A reasonably detailed outline of *B. subtilis* physiology with the identification of metabolic and developmental pathways were available in the late 70’s. The next milestone in microbiology became the availability of complete genome sequences, starting with *Haemophilus influenzae* in 1995. The *B. subtilis* genome sequence was released in 1997 [79] and among other things made genome-wide analysis of mRNA expression and large scale proteomics analysis a realistic project. However, this most certainly does not infer that the end of the story is near. The complete genome of *B. subtilis* comprises ~4100 genes and for ~1700, the so called *y*-genes, the function is still unknown. [79]. We have tried to shed some light over at least three of the *y*-genes (*ydiH*, *yjbI* and *yjbH*) in our studies.

In the following sections I will give a walkthrough of the model systems I have used in my research and of the different redox sensing systems in *B. subtilis*.

5.1 Cytochrome *bd*

The branched ETC of *B. subtilis* contains four terminal oxidases: cytochrome *caa*₃ (*ctaCDEF*), cytochrome *aa*₃ (*qoxABCD*), cytochrome *bd* (*cydAB*) and YthAB (Figure 2). In a batch culture, the major oxidase, encoded by *qoxABCD*, is constitutively expressed, while the minor oxidases encoded by *ctaCDEF* and by the *cydABCD* genes, are predominantly expressed in the later growth phases [149]. Cytochrome *bd* is often found to have a high affinity for oxygen. It is utilised when the oxygen tension is low in both *B. subtilis* and *E. coli* [145, 149]. The cytochrome *bd* promoter expression is affected by changed levels of aeration and the expression is high at low oxygen levels (Figure 15). Interestingly, cytochrome *bd* is not only found in aerobic bacteria but also in bacteria previously categorised as obligate anaerobes, such as *Moorella thermoacetica*, where the enzyme is used to protect against oxidative stress and contribute to the limited dioxygen tolerance of this organism [33].

The cytochrome *bd* operon is transcribed as a single message coding for four gene products. All four genes are essential for producing mature cytochrome *bd*. The *cydAB* genes codes for the structural genes and *cydCD* encodes a putative ABC transporter [149].

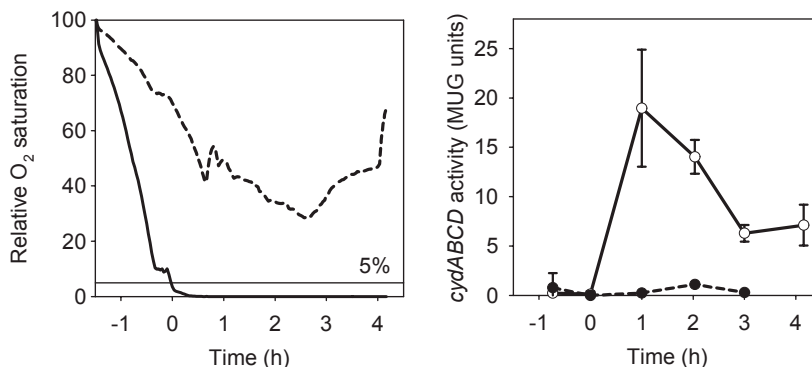

Figure 15 | Activity of the *cydABCD* promoter in cells grown under aerobic and microaerophilic conditions. The left panel shows the relative dissolved oxygen tension in a batch culture. The levels on the Y-axis are relative air-saturated medium. The right pane illustrates the expression from the cytochrome *bd* promoter as measured with a promoter-*lacZ* fusion construct. The solid lines represent low aeration (100 r.p.m.) and the dotted lines represent high aeration (400 r.p.m.). Time is relative to entry into the stationary growth phase.

The *cydABCD* operon is preceded by a 196 bp long 5' untranslated leader. In this region, the DNA-binding regulator Rex binds to three operators [132]. By truncation analysis we have shown that the region between -35 and -79 upstream from the transcription start is important for the expression of the *cyd* operon. If this region is removed, the transcriptional activity drops 15-fold (Figure 2, **Paper I**). A point mutation (A to G transition) at position -62 with the same effect has also been defined (unpublished data). A possible regulatory mechanism for the upstream region is a Class I activating system of the RNA polymerase (RNAP) where the α -subunit of RNAP interacts with an upstream regulatory element (UP). This interaction could be either *cis*-acting, between the α -subunit and DNA, or by using a *trans*-acting factor binding to the UP element and enhance the binding of RNAP [16]. The location of the important sequence upstream of -35 is indicative of the involvement of a Class I system [7]. There are only few examples of UP elements with direct interaction to the α -subunit described for *B. subtilis*, and

the motifs are vague with the only common feature of being AT-rich [40, 93]. The mechanism for the *cis*-acting activator is so far unknown (**Paper I**).

5.2 The truncated haemoglobin, YjbI

The long known and widely studied superfamily of haemoglobins has had a significant addition in the last ten years by the family of truncated haemoglobins (trHb) which forms a distinct group within the globin superfamily [150, 152].

It has been proposed that all globins originate from one ancestral protein [97] where the model defines a classical globin fold composed of eight α -helices with the core part trapping the haem with a 3-on-3 α -helical sandwich. The family of truncated haemoglobins utilises a reduced version of the classical globin fold with only six α -helices and the core part consisting of a 2-on-2 α -helical sandwich [150]. An interesting aspect is that even if the primary sequence homology between classical haemoglobins and trHbs is low, the tertiary homology between the 3-on-3 and 2-on-2 sandwiches is quite high with the four helices in the truncated haemoglobin closely matching four of the six helices in the myoglobin (Figure 16).

The trHbs are widely distributed throughout bacteria, protozoa and plants [150]. Typically, trHbs are expressed at nano- to micromolar intracellular concentrations in cells, hinting at a role as sensors or catalysts. Truncated haemoglobins in general and YjbI from *B. subtilis* in particular have a very high affinity for oxygen [53]. All of these traits present possibilities for a novel sensor in the truncated haemoglobin YjbI of *B. subtilis*.

The physiological function of trHbs has not yet been determined. Suggested functions for the trHbs include nitric oxide scavenging and detoxification [95, 116]. Our results from applying a nitrosative stress with SNP shows that the *yjbIH* operon may be required for a constitutive resistance against NO^+ attacks (**Paper II**). The transcription of the *yjbIH* genes, however, is not affected by SNP. This together with the low amounts of YjbI in the cells suggests that YjbIH acts as a sensor/regulator for NO protective enzymes rather than as a simple scavenger. The effect we have observed is probably exerted primarily via YjbH through the Spx regulon (**Paper III**).

The trHb YjbI is encoded by the *yjbIH* operon (**Paper II**) where *yjbI* codes for the trHb and *yjbH* codes for a protein that shares no similarity to proteins with known functions. In **Paper II and III** we explore the physiological role of YjbH and its effect on the global transcriptional regulator Spx [103, 107].

In our cytochrome *bd*-based model system for redox regulation, a deletion of *yjbIH* prevents expression of cytochrome *bd*. In our experiments, we consider it likely that this effect is indirect, as a function of that *yjbIH* null mutants never reach microaerobic conditions (**Paper I**, Figure 3).



Figure 16 | The trHb (Yjbl) from *B. subtilis*, (black) (PDB ID 1UX8) aligned to *Physeter catodon* (sperm whale) oxy-myoglobin, (white) (PDB ID 1A6M). The alignment is performed with combinatorial extension (CE) of an alignment path defined by aligned fragment pairs [133] (<http://cl.sdsc.edu/ce.html>). The method is based on local geometries rather than global features such as orientation of secondary structures and overall topology. The structural similarity with the four helices from Yjbl matching four of the six helices in the myoglobin is apparent, while the primary sequence similarity is only ~10%

5.3 ResDE-FNR-ArfM

B. subtilis, once considered an obligate aerobe, is now well known to be able to use both anaerobic respiration with nitrate and fermentation to grow anaerobically [63, 100]. The anaerobic growth states should probably be considered as a temporary solution for survival and



not a proper way of growth since strong lysis occurs when the cells enter stationary growth phase during anaerobic conditions [39].

There are two distinct nitrate reductases with separate functions; the respiratory membrane bound NarGHI and the assimilatory soluble NasBC. The nitrite reductase NasDE in contrast, is used for both nitrogen assimilation and dissimilatory nitrite respiration [104]. Mixed acid fermentation of pyruvate leads to mainly lactate, acetate, 2,3-butanediol, acetoin and ethanol as fermentation products [32, 100]. Anaerobic respiration has a much more favourable ATP yield than fermentation and a regulatory system is in place. The complete picture of the regulation in response to low oxygen is not known and no system in *B. subtilis* has such a major impact on the regulation as FNR and ArcAB in *E. coli*.

One of the key regulators in the anaerobic response is the pleiotropic two-component signal transduction system encoded by *resDE*, which is activated by a still unknown redox sensory mechanism [140]. The active components consist of ResE, a histidine sensor kinase and ResD, a DNA-binding response regulator. ResD and ResE are required for the transcription of *fnr* (a homologue to the *E. coli* FNR), *nasDEF* and a flavohaemoglobin encoded by *hmp* [81, 102, 105]. ResDE has also been shown to be an important regulator of fermentative enzymes such as lactate dehydrogenase (LDH) [32] and the induction of its own transcription [140].

FNR was in 1995 shown to be an activator of *narGHJI* and its accompanying nitrite extrusion protein encoded by *narK*, while repressing its own transcription [31]. By sequence homology the regulator encoded by *arfM* and a putative nitrite transporter *ywcJ* was also indicated to be activated by FNR. In 2000, the induction of lactate dehydrogenase *ldh-lctP* and *alsSD*, which is involved in acetoin synthesis, was added to the short list of FNR-dependent genes [32].

However, FNR and ResDE can only partially explain for the anaerobic induction of *ldh-lctP*, *alsSD*, *nasDE* and *hmp*. Marino et al. has proposed ArfM to be a modulating factor in this growing cascade of regulators [90].

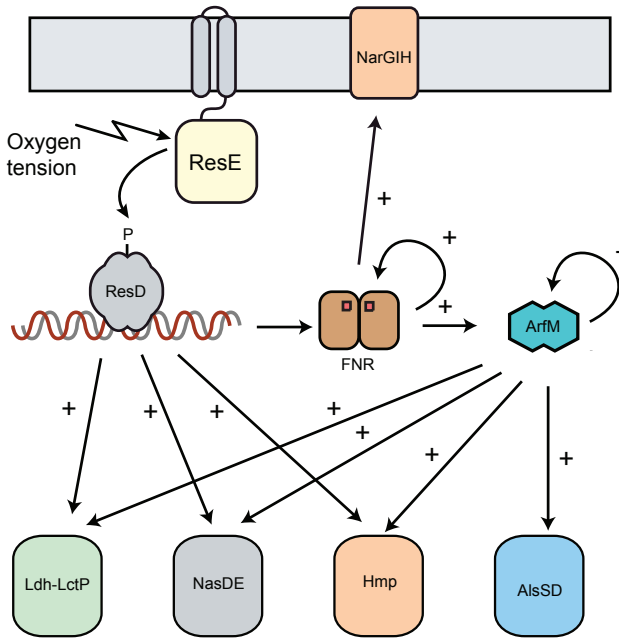

Figure 17 | The Res-FNR-Arf regulatory cascade in *B. subtilis*. The chain starting with ResDE induces the transcription of several operons (here symbolised by the gene products), among them *fnr*, which in turn probably has to form a dimer in response to low oxygen levels to become active and thereby creating a second point of control. The relay continues through a third transcriptional regulator ArfM. The environmental cue that triggers ResE is still unknown.

5.4 Rex

The most recent member of the group of regulatory proteins responding to oxygen/redox in *Firmicutes* is the redox sensing protein Rex (for mechanism see chapter 2.6). First discovered in *S. coelicolor* [15], Rex represents a new family of DNA binding pyridine nucleotide sensors that are widely spread within the gram-positive group. Rex can bind both NAD^+ and NADH but seems to have a higher affinity for NADH [15].

Rex (YdiH) from *B. subtilis* binds to operator sequences located between the core promoter and the translation start of *cydABCD* [132]. The repression of *cydABCD* by an NADH -dependent mechanism is in accordance with our findings that cytochrome *bd* is positively regulated at low oxygen levels, since when cells run out of oxygen, NADH starts to accumulate (Figure 18).

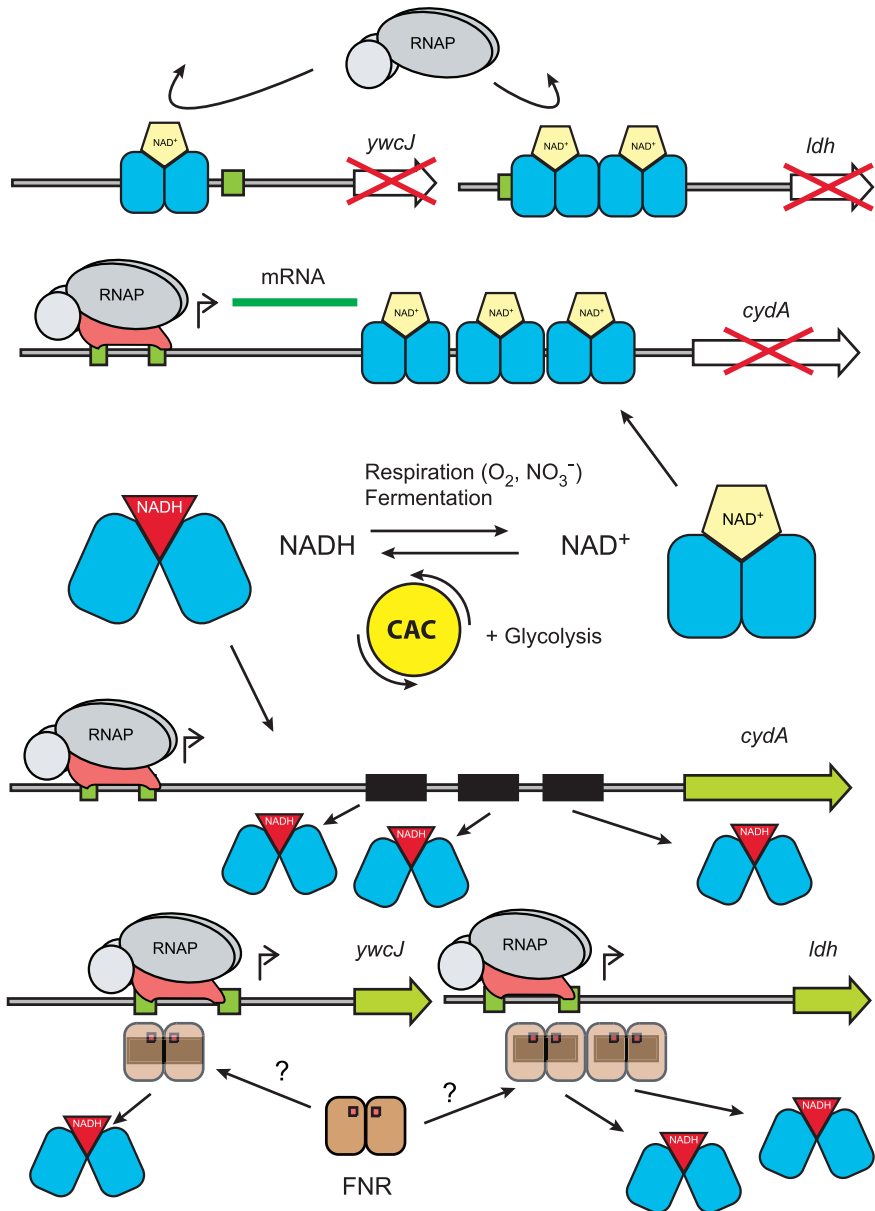

Figure 18 | Proposed model for Rex regulation in *B. subtilis*. When respiration or fermentation is active the fraction of NAD^+ to $NADH$ is high. Rex binds NAD^+ and in this conformation is able to bind DNA, which blocks transcription initiation at the *ldh* and *ywcJ* promoters and results in a roadblock style repression of *cydABCD*. If the energy conserving reactions are stalled, the citric acid cycle and glycolysis will shift the NAD^+ / $NADH$ equilibrium towards $NADH$. Rex binds $NADH$ with higher affinity than NAD^+ , and Rex- $NADH$ is unable to bind to its operator sequences. This heaves the block and enables transcription initiation. However, since the Rex operator sequence shares a high similarity with the operator for FNR, competition for the site by FNR is a possibility. This also makes good sense in some cases, e.g. if the cell faces high $NADH$ levels while respiring with



nitrate, the cell is already under a nitrite stress and should not import more nitrite by YwcJ. Also, it makes no sense to ferment via lactate dehydrogenase since that would be a waste of energy.

We have extended the range of regulated genes in the Rex regulon and can show that a coordinated regulatory pattern is found for *cydABCD*, the L-lactate dehydrogenase *ldh*, and the putative nitrite transporter *ywcJ* [83]. This all fits nicely together: LDH is needed for fermentation of pyruvate to lactate, and a strain lacking *ldh* has a severe growth defect under anaerobic conditions [32]. LDH expression has been reported to be dependent on both *fnr* and *resDE* [89]. Notable is that the direct *fnr* dependency has been challenged as a secondary effect of FNR-activated ArfM [90]. We found that the Rex DNA-binding motif in *B. subtilis* shares a similarity to the reported FNR-binding motif (**Paper I**). This makes room for an interesting regulatory possibility where FNR and Rex could compete for the same motif, where FNR would sense oxygen directly via oxygen-sensitive Fe-S clusters, and Rex would sense oxygen-limitation and general “bad times” in the cell via the altered NAD⁺/NADH pool. This regulation added to the direct influence of ResDE (by an unknown redox cue) gives a system with many possibilities for an integrative response is present. The third promoter we have shown to be regulated by Rex in *B. subtilis* precedes the gene *ywcJ* that shows sequence similarity to the *nirC* gene in *E. coli*. The transmembrane NirC was recently shown to function as a nitrite importer rather than an exporter [22]. It is plausible to consider that this is another means of increasing *B. subtilis* energy production by importing nitrite to the dissimilatory nitrite reductase *nasBC*. The physiological role of NasBC seems to be twofold: to detoxify cells from nitrite and to regenerate NAD⁺ from NADH [50]. The latter function could be a reasonable cause as to why Rex in *B. subtilis* upregulates the gene since, among other things, the glycolysis is dependent on fresh NAD⁺. Does Rex have additional targets? It is quite likely since bioinformatic approaches presently conducted with genome-wide searches in species hosting Rex homologues with identical DNA binding domains, show a number of candidate regulatory genes that would be likely to be expressed at low oxygen levels. Candidates include e.g. alcohol dehydrogenases which can help keep up the energy production when the going gets rough.

5.5 The σ^B general stress regulon

Bacteria encounter many types of stress and as a complement to specific sensor-response systems *B. subtilis* is furnished with a large set of genes that are activated in a concerted response to several types of stress. In the laboratory stresses proven to induce this response include salt, acid, heat, cold and ethanol as well as limiting amounts of glucose, phosphate and oxygen. The regulon contains 150-200 genes [119, 124], some whose function is known. Examples include catalase for hydrogen peroxide detoxification, thioredoxin for reducing unwanted disulphide bonds and protease to remove damaged proteins. Many others are not yet characterised but great progress has been made in recent years [67, 99, 119]. The stress regulon is controlled by the alternative sigma factor σ^B , discovered in 1979 by Haldenwang and Losick [59]. The physiological function as a stress regulator was not understood until over a decade later [10, 12, 13]. The importance of the regulon can be indicated by the massive up regulation of proteins that occurs in stressed cells. At induced conditions the σ^B dependent gene products are responsible for up to 40% of the total amount of synthesised proteins [11].

Several types of stress can be responsible for induction of σ^B , but not all types of stress activate all promoters of the regulon [67]. The diverse stresses that elicit a σ^B response can be grouped into three classes: energy stresses such as carbon, oxygen or phosphate starvation, environmental stresses such as ethanol, heat or salt, and the third stress, cold, for which the regulatory mechanism has not yet been found. The sigma factor itself (SigB) is regulated posttranscriptionally by partner switching between the anti-sigma factor RsbW and the anti-anti-sigma factor RsbV. At non-stressed conditions RsbW keeps SigB inactive and RsbV unphosphorylated. When stress is confronted RsbV is desphosphorylated by serine phosphatases. The energy and environmental specific branches of the pathway are regulated via the serine phosphatases RsbP and RsbU respectively.

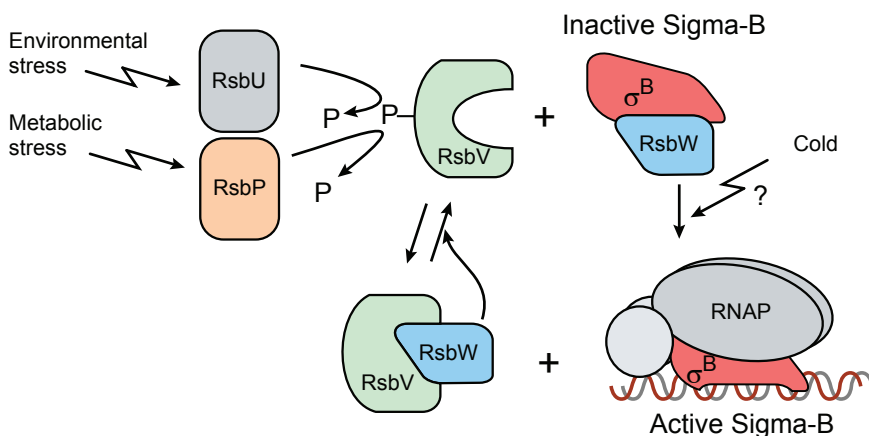

Figure 19 | The regulation of the sigma^B general stress regulon. The stress sigma factor is subject to a partner switch regulation where RsbW acts as the anti-sigma factor and can be switched to the anti-anti-sigma factor RsbV during stress. Stress is sensed via three pathways where environmental and metabolic stress signals are transmitted via the phosphatases RsbU and RsbP. The phosphatases activates RsbV and RsbV now binds RsbW with subsequent release of σ^B . The low kinase activity bestowed on RsbV by RsbW switches off the regulon when RsbU and RsbP are no longer active as phosphatases.

In **Paper I** we have characterised the regulator Rex in *B. subtilis* and exposed a Rex null mutant to oxygen limiting conditions. The microarray study shows that after five minutes of oxygen limitation exposure to exponentially growing cells 103 transcripts are up regulated. Of these 54 belong to the σ^B stress regulon. Neither wild-type, nor a *yjbIH* null mutant strain show any signs of a σ^B activation. The activating pathway within the σ^B regulon was mapped and found to be through the metabolic pathway (RsbP).

In **Paper II** we show that five minutes of exposure to 0.5 mM SNP to exponentially growing cells significantly up-regulates 181 genes. Of these, 81 are controlled by σ^B . Interestingly a *sigB* null mutant strain is not more sensitive to SNP. Furthermore, 10 putative new σ^B dependent genes were identified by being induced by SNP in wild-type cells but not in σ^B null mutant cells.



5.6 Spx

Spx is a unique RNA polymerase(RNAP)-binding protein widely spread in the low-G+C gram-positive bacteria. Spx is unique in that it exerts its regulatory function by binding to the α -subunit of the C-terminus of RNAP and interferes with the transcriptional activation [107]. Even though Spx lacks apparent DNA-binding motifs it has also been shown to be able to act as an activator of certain transcripts [106]. At a non-stressed cellular state, Spx is rapidly degraded by the ATP-dependent protease ClpXP [108]. This post-translational regulation is thought to be the major mechanism for regulating Spx levels.

A ClpXP mutant has a pleiotropic phenotype including blocked competence, sporulation deficiency and severe growth impairment. Loss of function mutations in Spx can at least partly compensate for a ClpXP null mutant, indicating that Spx is the major effector of the ClpXP phenotype [101].

ClpXP recognises the SsrA-like C-terminus sequence of Spx as the signal for degradation, and exchanging the last two amino acids in the Spx peptide results in a ClpXP-insensitive protein [106]. The C-terminal modified mutant producing Spx has been subject to transcriptome profiling and the regulon was found to comprise a large set of genes involved in competence and primary metabolism including purine, pyrimidine and amino acid synthesis genes. Interestingly, in this array study, some genes were found to be positively regulated by Spx, including the thioredoxin (*trxA*) and thioredoxin reductase (*trxB*) genes which are used to handle erroneously formed disulphide bonds [106]. Diamide is a substance promoting disulphide bond formation and Spx null mutants grow poorly when diamide is present. In a cell under diamide stress, native Spx is less prone to proteolysis. This can either be due to modification of a CXXC motif (which is a motif prone to disulphide bond formation) in Spx or inhibited ClpXP activity [154].

Our own research has shown that a YjbH null mutant has a milder phenotype of the same kind as a ClpXP null mutant (sporulation, competence, growth deficiency, **Paper III**). We observed and characterised suppressors which were relieved of these defects and mapped them to the *spx* locus. Spx is a positive regulator of *yjbIH* [106] and we can show that *yjbH* has an autoregulatory effect on the *yjbIH* operon and that this effect most likely is exerted via Spx induction. We also suggest that YjbH is a negative posttranslational regulator of the Spx protein (**Paper I**).

“Everything should be as simple as possible, but not simpler.”
Albert Einstein

Chapter 6 Summary of Papers

Paper I: Coordinated Patterns of Cytochrome *bd* and Lactate dehydrogenase Expression in *Bacillus subtilis*

Three *B. subtilis* transcriptional units, *cydABCD* (high affinity terminal oxidase), *ldh lctP* (L-lactate dehydrogenase and permease) and *ywcJ* (putative nitrite transporter), known to be induced under microaerobic or anaerobic growth conditions, are shown to be directly regulated by Rex (previously named YdiH). In *Streptomyces coelicolor*, Rex modulates transcription in response to changes in the cellular NAD^+/NADH ratio. Rex binds both the oxidised and reduced form but only the binding of NADH confers loss of activity. Based on analogy, *B. subtilis* Rex is likely to serve as a redox sensor regulated by cellular differences in the free levels of NAD^+ and NADH.

The ResDE two-component system has previously been shown to affect the expression of *ldh lctP* both directly via ResD and indirectly through FNR. Expression of *ywcJ* has been shown to depend on FNR for activation. However, neither ResDE nor FNR significantly influences transcription of the *cydABCD* genes. The expression pattern of *ldh lctP* and *ywcJ* is shown to be similar to that of the *cyd* genes. Rex acts as a negative regulator to coordinate the expression of these genes during the transition from aerobic to anaerobic growth.

Rex is a principal regulator of *cydABCD* expression. However, additional factors control expression of the *cyd* genes. Sequences upstream of the core *cyd* promoter significantly stimulate promoter activity suggesting involvement of an unidentified activator. This activation influences the level of transcription but not its timing, which is negatively controlled by Rex.

A rapid shift to oxygen-starved conditions activates the σ^B -dependent general stress response in a strain lacking Rex. Activation of σ^B under these circumstances is primarily dependent on the energy-stress sensor, RsbP.

Paper II: *Bacillus subtilis* Possess both Constitutive and Inducible Elements for Alleviation of Nitrosative Stress

B. subtilis is shown to counteract nitrosative stress by two systems. The flavohaemoglobin Hmp confers an inducible stress tolerance while the action of gene products from the *yjbIH* operon results in a constitutive tolerance. The effect is additive and exerted by different mechanisms.

The free radical nitric oxide (NO^\cdot) exerts a toxic effect to cells by binding to heme-, iron- and copper-proteins, and together with reactive oxygen species (ROS), forming a variety of reactive nitrogen species (RNS). RNS react with many cellular components, resulting in inhibition of



respiration and other key cellular processes. *B. subtilis* Hmp is induced by non-toxic amounts of sodium nitro-prusside (SNP), resulting in 10 times higher tolerance against nitrosative stress. YjbH gives a non-inducible protection and a null mutant was shown to exhibit 100 times lower tolerance to SNP. Transcriptome profiling identified 181 up-regulated and 89 repressed genes in SNP-exposed cells. More than half of the induced genes belong to the σ^B general stress regulon. The levels of the transcripts corresponding to *yjbI* and *yjbH* were not affected while *hmp* was among the most highly up-regulated genes, consistent with the involvement of *hmp* in the adaptive response to SNP. The *hmp* gene has been reported to be highly induced by ResDE, however, neither a *sigB* nor a *resDE* null mutant showed increased sensitivity to SNP nor did the mutations affect the induced resistance.

The data presented suggest that the σ^B -dependent stress proteins are involved in a non-specific protection against stress whereas Hmp-Bs and YjbH are crucial components for surviving nitrosative stress.

Paper III: YjbH is a Novel Negative Effector of the Global Transcriptional Regulator, Spx, in *Bacillus subtilis*.

The *yjbIH* operon of *B. subtilis* encodes a truncated haemoglobin (YjbI) and a predicted 34 kDa cytosolic protein of unknown function (YjbH). Deletion of *yjbH* gives the cells a pleiotropic phenotype with poor growth, impaired sporulation and no detectable competence development. Suppressor mutations that bypass the defects were isolated and localized to the *spx* gene, which codes for a global regulator responsive to disulphide stress. Among the Spx-controlled genes are thioredoxin (*trxA*) and thioredoxin reductase (*trxB*), which play a key role in maintaining the intracellular redox state. Spx concentration increases during stress due to decreased activity of the ClpXP protease. Disulphide stress up-regulates the *yjbIH* operon, most likely via Spx. We show that YjbH has an autoregulatory effect on the *yjbIH* operon, most likely via Spx induction. Cells lacking *yjbIH* have an apparent down- and up-regulation of several transcripts that belong to the Spx regulon but do not affect the level of transcription from the *spx* promoter.

It is suggested that the *yjbH* gene encodes a negative effector of Spx that posttranscriptionally regulates the concentration of Spx, perhaps by affecting the degradation of Spx by ClpXP.

Now go back and read the other pages first! Done that already? Yeah, right...

Chapter 7 Acknowledgments

I would like to thank a number of persons for making this dissertation a possibility. Without some of them, I would not have been here at all and without others, I would never have been able to finish the work. And then there are the people that without whom the time spent here would have been a lot less fun.

First and foremost my supervisor Claes von Wachenfeldt, who is everything you could wish for as a boss. Without his enthusiasm, ingenuity and trust in me from the degree project last millennium and all the way until now, this work could not have been realised.

All the people that have worked with me during the years, dang, I will miss you. Sodium-nitro-Annika who has endured countless of hours slaving in our projects, first as a degree student and then in a variety of projects and finally as a PhD student and co-worker. You make the lab a much more fun and musical place. Little Peter who *always* will be the youngest person in the department and who knows how to put fire onto the floor. Lena Winstedt, who helped me as a lost beginner, the lab never became what it used to be (no more smashing of glass, cursing, general noisemaking and non-successful inoculations, but most of all great fun). Exam workers, missy Jess, DJ Shy, Erika, Martin-Blåkläder, Mia, Nathan and others, thanks for all the fun.

A special thanks goes to all the former and current roomies in the Mongorummet who has to put up with my mess and all my coffee mugs. Mirja and Anna, the Gerda-holics, great to have with you at conferences so you can snore them to death, good mates on the pub with beers, even if there is a bad pomme sometimes. Emil, who I just love to hit in the head with a stick, Sabá and Mari who now finally can keep the door closed. Mia, always a story to tell and more fun than you could shake a stick at.

Department people. Lars Hedersted who always have a good science advice ready. Il professori Blanka and Lars (always a French philosophers quote ready) who together with Lars-Anki-Olof, Sten (Don't break another foot at my party!) and Einar "Smuk som et stjernesked" are the reasons that I became interested in microbiology. Karin, Per, Yvonne and Stefan for making sure that everything runs ever so smoothly around the department. And of course all other persons working around the place, plant physiologists, geneticists, the Danish crew, I'll miss you.

The golden oldies, PhD students during the years at the department. Lena Frankentasse - wonderful friend, always good to have handy if you wish to take a dip into the University fountain, now get a summer house here in Sweden! Mimmi - Nørskcutvandrare who *really* knows how to eat garlic sauce, Mattias - the ragamuffin tråskodunk, Gustav - jagtarbene-navsoffansåserlāgenhetenstörreut, Jenny - the seminar sleeper, Lydur - who knows how to eat rotten shark, Martin - raw eggs is really good, Linda - who dances in the lab.

A big thank you to all my friends who (I hope) have not forgotten about me just because I have totally ignored you for quite some time now, you mean so much to me!

Emma, for being there for me and who has put up with me during all of this!

References

1. **Abrahams, J. P., A. G. Leslie, R. Lutter, and J. E. Walker.** 1994. Structure at 2.8 Å resolution of F₁-ATPase from bovine heart mitochondria. *Nature* **370**:621-8.
2. **Achebach, S., T. Selmer, and G. Uden.** 2005. Properties and significance of apoFNR as a second form of air-inactivated [4Fe-4S]-FNR of *Escherichia coli*. *FEBS J* **272**:4260-9.
3. **Aleryani, S., E. Milo, and P. Kostka.** 1999. Formation of peroxynitrite during thiol-mediated reduction of sodium nitroprusside. *Biochim Biophys Acta* **1472**:181-90.
4. **Alexeeva, S., K. J. Hellingwerf, and M. J. Teixeira de Mattos.** 2003. Requirement of ArcA for redox regulation in *Escherichia coli* under microaerobic but not anaerobic or aerobic conditions. *J Bacteriol* **185**:204-9.
5. **Anagnostopoulos, C., and J. Spizizen.** 1961. Requirements for transformation in *Bacillus subtilis*. *J Bacteriol* **81**:741-6.
6. **Ballard, A. L., and S. J. Ferguson.** 1988. Respiratory nitrate reductase from *Paracoccus denitrificans*. Evidence for two b-type haems in the gamma subunit and properties of a water-soluble active enzyme containing alpha and beta subunits. *Eur J Biochem* **174**:207-12.
7. **Barnard, A., A. Wolfe, and S. Busby.** 2004. Regulation at complex bacterial promoters: how bacteria use different promoter organizations to produce different regulatory outcomes. *Curr Opin Microbiol* **7**:102-8.
8. **Bauer, C. E., S. Elsen, and T. H. Bird.** 1999. Mechanisms for redox control of gene expression. *Annu Rev Microbiol* **53**:495-523.
9. **Bell, P. J., S. C. Andrews, M. N. Sivak, and J. R. Guest.** 1989. Nucleotide sequence of the FNR-regulated fumarase gene (*fumB*) of *Escherichia coli* K-12. *J Bacteriol* **171**:3494-503.
10. **Benson, A. K., and W. G. Haldenwang.** 1993. The sigma B-dependent promoter of the *Bacillus subtilis* sigB operon is induced by heat shock. *J Bacteriol* **175**:1929-35.
11. **Bernhardt, J., U. Völker, A. Völker, H. Antemann, R. Schmid, H. Mach, and M. Hecker.** 1997. Specific and general stress proteins in *Bacillus subtilis* – a two-dimensional protein electrophoresis study. *Microbiology* **143**:999-1017.
12. **Boylan, S. A., A. R. Redfield, M. S. Brody, and C. W. Price.** 1993. Stress-induced activation of the sigma B transcription factor of *Bacillus subtilis*. *J Bacteriol* **175**:7951-7.
13. **Boylan, S. A., A. Rutherford, S. M. Thomas, and C. W. Price.** 1992. Activation of *Bacillus subtilis* transcription factor sigma B by a regulatory pathway responsive to stationary-phase signals. *J Bacteriol* **174**:3695-706.
14. **Braatsch, S., M. Gomelsky, S. Kuphal, and G. Klug.** 2002. A single flavoprotein, AppA, integrates both redox and light signals in *Rhodobacter sphaeroides*. *Mol Microbiol* **45**:827-36.
15. **Brekasis, D., and M. S. Paget.** 2003. A novel sensor of NADH/NAD⁺ redox poise in *Streptomyces coelicolor* A3(2). *EMBO J* **22**:4856-65.
16. **Browning, D. F., and S. J. W. Busby.** 2004. The regulation of bacterial transcription initiation. *Nature Reviews Microbiology* **2**:57-65.
17. **Bruckdorfer, R.** 2005. The basics about nitric oxide. *Mol Aspects Med* **26**:3-31.
18. **Burkholder, P. R., and J. Norman H. Giles.** 1947. Induced biochemical mutations in *Bacillus subtilis*. *American journal of botany* **34**:345-348.
19. **Carlouz, A., and D. Touati.** 1986. Isolation of superoxide dismutase mutants in *Escherichia coli*: is superoxide dismutase necessary for aerobic life? *EMBO J* **5**:623-30.
20. **Chang, A. L., J. R. Tuckerman, G. Gonzalez, R. Mayer, H. Weinhouse, G. Volman, D. Amikam, M. Benziman, and M. A. Gilles-Gonzalez.** 2001. Phosphodiesterase A1, a regulator of cellulose synthesis in *Acetobacter xylinum*, is a heme-based sensor. *Biochemistry* **40**:3420-6.
21. **Chao, G., J. Shen, C. P. Tseng, S. J. Park, and R. P. Gunsalus.** 1997. Aerobic regulation of isocitrate dehydrogenase gene (*icd*) expression in *Escherichia coli* by the *arcA* and *fnr* gene products. *J Bacteriol* **179**:4299-304.
22. **Clegg, S., F. Yu, L. Griffiths, and J. A. Cole.** 2002. The roles of the polytopic membrane proteins NarK, NarU and NirC in *Escherichia coli* K-12: two nitrate and three nitrite transporters. *Mol Microbiol* **44**:143-55.
23. **Cohen-Bazire, G., W. R. Sistrom, and R. Y. Stanier.** 1957. Kinetic studies of pigment synthesis by non-sulfur purple bacteria. *J Cell Physiol* **49**:25-68.
24. **Cohn, F.** 1877. Untersuchungen über Bakterien IV. Beiträge zur Biologie der Bacillen. *Beitr Biol Pflanz* **2**:249-276.
25. **Cole, J.** 1996. Nitrate reduction to ammonia by enteric bacteria: redundancy, or a strategy for survival during oxygen starvation? *FEMS Microbiol Lett* **136**:1-11.
26. **Cotter, P. A., V. Chepuri, R. B. Gennis, and R. P. Gunsalus.** 1990. Cytochrome *o* (*cyoABCDE*) and *d* (*cydAB*) oxidase gene expression in *Escherichia coli* is regulated by oxygen, pH, and the *fnr* gene product. *J Bacteriol* **172**:6333-8.
27. **Cotter, P. A., and R. P. Gunsalus.** 1992. Contribution of the *fnr* and *arcA* gene products in coordinate regulation of cytochrome *o* and *d* oxidase (*cyoABCDE* and *cydAB*) genes in *Escherichia coli*. *FEMS Microbiol Lett* **70**:31-6.



28. **Cotter, P. A., S. B. Melville, J. A. Albrecht, and R. P. Gunsalus.** 1997. Aerobic regulation of cytochrome *d* oxidase (*cydAB*) operon expression in *Escherichia coli*: roles of Fnr and ArcA in repression and activation. *Mol Microbiol* **25**:605-15.
29. **Craske, A., and S. J. Ferguson.** 1986. The respiratory nitrate reductase from *Paracoccus denitrificans*. Molecular characterisation and kinetic properties. *Eur J Biochem* **158**:429-36.
30. **Crespo, A., M. A. Marti, S. G. Kalko, A. Morreale, M. Orozco, J. L. Gelpi, F. J. Luque, and D. A. Estrin.** 2005. Theoretical study of the truncated hemoglobin HbN: exploring the molecular basis of the NO detoxification mechanism. *J Am Chem Soc* **127**:4433-44.
31. **Cruz Ramos, H., L. Boursier, I. Moszer, F. Kunst, A. Danchin, and P. Glaser.** 1995. Anaerobic transcription activation in *Bacillus subtilis*: identification of distinct FNR-dependent and -independent regulatory mechanisms. *EMBO J* **14**:5984-94.
32. **Cruz Ramos, H., T. Hoffmann, M. Marino, H. Nedjari, E. Presecan-Siedel, O. Dreesen, P. Glaser, and D. Jahn.** 2000. Fermentative metabolism of *Bacillus subtilis*: physiology and regulation of gene expression. *J Bacteriol* **182**:3072-80.
33. **Das, A., R. Silaghi-Dumitrescu, L. G. Ljungdahl, and D. M. Kurtz, Jr.** 2005. Cytochrome *bd* oxidase, oxidative stress, and dioxygen tolerance of the strictly anaerobic bacterium *Moorella thermoacetica*. *J Bacteriol* **187**:2020-9.
34. **de Jesus-Berrios, M., L. Liu, J. C. Nussbaum, G. M. Cox, J. S. Stamler, and J. Heitman.** 2003. Enzymes that counteract nitrosative stress promote fungal virulence. *Curr Biol* **13**:1963-8.
35. **Delgado-Nixon, V. M., G. Gonzalez, and M. A. Gilles-Gonzalez.** 2000. Dos, a heme-binding PAS protein from *Escherichia coli*, is a direct oxygen sensor. *Biochemistry* **39**:2685-91.
36. **Ding, H., and B. Dimple.** 2000. Direct nitric oxide signal transduction via nitrosylation of iron-sulfur centers in the SoxR transcription activator. *Proc Natl Acad Sci U S A* **97**:5146-50.
37. **Drews, G.** 2000. The roots of microbiology and the influence of Ferdinand Cohn on microbiology of the 19th century. *FEMS Microbiol Rev* **24**:225-49.
38. **Elsen, S., L. R. Swem, D. L. Swem, and C. E. Bauer.** 2004. RegB/RegA, a highly conserved redox-responding global two-component regulatory system. *Microbiol Mol Biol Rev* **68**:263-79.
39. **Espinosa-de-los-Monteros, J., A. Martinez, and F. Valle.** 2001. Metabolic profiles and *aprE* expression in anaerobic cultures of *Bacillus subtilis* using nitrate as terminal electron acceptor. *Appl Microbiol Biotechnol* **57**:379-84.
40. **Estrem, S. T., T. Gaal, W. Ross, and R. L. Gourse.** 1998. Identification of an UP element consensus sequence for bacterial promoters. *Proc Natl Acad Sci U S A* **95**:9761-6.
41. **Fang, F. C.** 2004. Antimicrobial reactive oxygen and nitrogen species: concepts and controversies. *Nat Rev Microbiol* **2**:820-32.
42. **Farr, S. B., R. D'Ari, and D. Touati.** 1986. Oxygen-dependent mutagenesis in *Escherichia coli* lacking superoxide dismutase. *Proc Natl Acad Sci U S A* **83**:8268-72.
43. **Firoved, A. M., S. R. Wood, W. Ornatowski, V. Deretic, and G. S. Timmins.** 2004. Microarray analysis and functional characterization of the nitrosative stress response in nonmucoid and mucoid *Pseudomonas aeruginosa*. *J Bacteriol* **186**:4046-50.
44. **Fjeld, C. C., W. T. Birdsong, and R. H. Goodman.** 2005. Differential binding of NAD⁺ and NADH allows the transcriptional corepressor carboxyl-terminal binding protein to serve as a metabolic sensor. *Proc Natl Acad Sci U S A* **100**:9202-7.
45. **Flint, D. H., E. Smyk-Randall, J. F. Tuminello, B. Draczynska-Lusiak, and O. R. Brown.** 1993. The inactivation of dihydroxy-acid dehydratase in *Escherichia coli* treated with hyperbaric oxygen occurs because of the destruction of its Fe-S cluster, but the enzyme remains in the cell in a form that can be reactivated. *J Biol Chem* **268**:25547-52.
46. **Flint, D. H., J. F. Tuminello, and M. H. Emptage.** 1993. The inactivation of Fe-S cluster containing hydro-lyases by superoxide. *J Biol Chem* **268**:22369-76.
47. **Fuangthong, M., and J. D. Helmann.** 2002. The OhrR repressor senses organic hydroperoxides by reversible formation of a cysteine-sulfenic acid derivative. *Proc Natl Acad Sci U S A* **99**:6690-5.
48. **Gardner, P. R.** 2005. Nitric oxide dioxygenase function and mechanism of flavohemoglobin, hemoglobin, myoglobin and their associated reductases. *J Inorg Biochem* **99**:247-66.
49. **Gardner, P. R., and I. Fridovich.** 1991. Superoxide sensitivity of the *Escherichia coli* aconitase. *J Biol Chem* **266**:19328-33.
50. **Gennis, R. B., and V. Stewart.** 1996. Respiration, p. 217-261. *In* F. C. Neidhart (ed.), *Escherichia coli* and *Salmonella*: cellular and molecular biology, 2nd ed. ASM Press, Washington, D. C.
51. **Georgellis, D., O. Kwon, and E. C. Lin.** 2001. Quinones as the redox signal for the *arc* two-component system of bacteria. *Science* **292**:2314-6.
52. **Georgellis, D., A. S. Lynch, and E. C. Lin.** 1997. In vitro phosphorylation study of the *arc* two-component signal transduction system of *Escherichia coli*. *J Bacteriol* **179**:5429-35.
53. **Giangiacomo, L., A. Ilari, A. Boffi, V. Morea, and E. Chiancone.** 2005. The truncated oxygen-avid hemoglobin from *Bacillus subtilis*: X-ray structure and ligand binding properties. *J Biol Chem* **280**:9192-202.
54. **Gilles-Gonzalez, M. A., and G. Gonzalez.** 2005. Heme-based sensors: defining characteristics, recent developments, and regulatory hypotheses. *J Inorg Biochem* **99**:1-22.



55. **Gilles-Gonzalez, M. A., and G. Gonzalez.** 2004. Signal transduction by heme-containing PAS-domain proteins. *J Appl Physiol* **96**:774-85.
56. **Gilles-Gonzalez, M. A., G. Gonzalez, and M. F. Perutz.** 1995. Kinase activity of oxygen sensor FixL depends on the spin state of its heme iron. *Biochemistry* **34**:232-6.
57. **Gomelsky, M., and S. Kaplan.** 1997. Molecular genetic analysis suggesting interactions between AppA and PpsR in regulation of photosynthesis gene expression in *Rhodobacter sphaeroides* 2.4.1. *J Bacteriol* **179**:128-34.
58. **Gottlieb, S. F.** 1971. Effect of hyperbaric oxygen on microorganisms. *Annu Rev Microbiol* **25**:111-52.
59. **Haldenwang, W. G., and R. Losick.** 1979. A modified RNA polymerase transcribes a cloned gene under sporulation control in *Bacillus subtilis*. *Nature* **282**:256-60.
60. **Han, Y., S. Braatsch, L. Osterloh, and G. Klug.** 2004. A eukaryotic BLUF domain mediates light-dependent gene expression in the purple bacterium *Rhodobacter sphaeroides* 2.4.1. *Proc Natl Acad Sci U S A* **101**:12306-11.
61. **Harrison, D. G., and J. N. Bates.** 1995. The nitrovasodilators. New ideas about old drugs. *Circulation* **87**:1461-7.
62. **Hill, S., S. Austin, T. Eydmann, T. Jones, and R. Dixon.** 1996. *Azotobacter vinelandii* NIFL is a flavoprotein that modulates transcriptional activation of nitrogen-fixation genes via a redox-sensitive switch. *Proc Natl Acad Sci U S A* **93**:2143-8.
63. **Hoffmann, T., N. Frankenberger, M. Marino, and D. Jahn.** 1998. Ammonification in *Bacillus subtilis* utilizing dissimilatory nitrite reductase is dependent on *resDE*. *J Bacteriol* **180**:186-9.
64. **Hou, S., T. Freitas, R. W. Larsen, M. Piatibratov, V. Sivozhelzov, A. Yamamoto, E. A. Meleshkevitch, M. Zimmer, G. W. Ordal, and M. Alam.** 2001. Globin-coupled sensors: a class of heme-containing sensors in Archaea and Bacteria. *Proc Natl Acad Sci U S A* **98**:9353-8.
65. **Hou, S., R. W. Larsen, D. Boudko, C. W. Riley, E. Karatan, M. Zimmer, G. W. Ordal, and M. Alam.** 2000. Myoglobin-like aerotaxis transducers in Archaea and Bacteria. *Nature* **403**:540-4.
66. **Hughes, M. N.** 1999. Relationships between nitric oxide, nitroxyl ion, nitrosonium cation and peroxyxynitrite. *Biochim Biophys Acta* **1411**:263-72.
67. **Höper, D., U. Völker, and M. Hecker.** 2005. Comprehensive characterization of the contribution of individual SigB-dependent general stress genes to stress resistance of *Bacillus subtilis*. *J Bacteriol* **187**:2810-26.
68. **Iuchi, S., V. Chepuri, H. A. Fu, R. B. Gennis, and E. C. Lin.** 1990. Requirement for terminal cytochromes in generation of the aerobic signal for the *arc* regulatory system in *Escherichia coli*: study utilizing deletions and lac fusions of *cyo* and *cyd*. *J Bacteriol* **172**:6020-5.
69. **John, P.** 1977. Aerobic and anaerobic bacterial respiration monitored by electrodes. *J Gen Microbiol* **98**:231-8.
70. **Jormakka, M., S. Törnroth, B. Byrne, and S. Iwata.** 2002. Molecular basis of proton motive force generation: structure of formate dehydrogenase-N. *Science* **295**:1863-8.
71. **Kang, J. G., M. S. Paget, Y. J. Seok, M. Y. Hahn, J. B. Bae, J. S. Hahn, C. Kleanthous, M. J. Buttner, and J. H. Roe.** 1999. RsrA, an anti-sigma factor regulated by redox change. *Embo J* **18**:4292-8.
72. **Kehrer, J. P.** 2000. The Haber-Weiss reaction and mechanisms of toxicity. *Toxicology* **149**:43-50.
73. **Kiley, P. J., and H. Beinert.** 1998. Oxygen sensing by the global regulator, FNR: the role of the iron-sulfur cluster. *FEMS Microbiol Rev* **22**:341-52.
74. **Kiley, P. J., and H. Beinert.** 2003. The role of Fe-S proteins in sensing and regulation in bacteria. *Curr Opin Microbiol* **6**:181-5.
75. **Kiley, P. J., and S. Kaplan.** 1988. Molecular genetics of photosynthetic membrane biosynthesis in *Rhodobacter sphaeroides*. *Microbiol Rev* **52**:50-69.
76. **Kim, S. O., K. Merchant, R. Nudelman, W. F. Beyer, Jr., T. Keng, J. DeAngelo, A. Hausladen, and J. S. Stamler.** 2002. OxyR: a molecular code for redox-related signaling. *Cell* **109**:383-96.
77. **Krieger-Liszkay, A.** 2005. Singlet oxygen production in photosynthesis. *J Exp Bot* **56**:337-46.
78. **Kudo, S., J. L. Bourassa, S. E. Boggs, Y. Sato, and P. C. Ford.** 1997. *In situ* nitric oxide (NO) measurement by modified electrodes: NO labilized by photolysis of metal nitrosyl complexes. *Anal Biochem* **247**:193-202.
79. **Kunst, F., N. Ogasawara, I. Moszer, A. M. Albertini, G. Alloni, V. Azevedo, M. G. Bertero, P. Bessieres, A. Bolotin, S. Borchert, R. Borriss, L. Boursier, A. Brans, M. Braun, S. C. Brignell, S. Bron, S. Brouillet, C. V. Bruschi, B. Caldwell, V. Capuano, N. M. Carter, S. K. Choi, J. J. Codani, I. F. Connerton, A. Danchin, et al.** 1997. The complete genome sequence of the gram-positive bacterium *Bacillus subtilis*. *Nature* **390**:249-56.
80. **Kwon, O., D. Georgellis, A. S. Lynch, D. Boyd, and E. C. Lin.** 2000. The ArcB sensor kinase of *Escherichia coli*: genetic exploration of the transmembrane region. *J Bacteriol* **182**:2960-6.
81. **LaCelle, M., M. Kumano, K. Kurita, K. Yamane, P. Zuber, and M. M. Nakano.** 1996. Oxygen-controlled regulation of the flavohemoglobin gene in *Bacillus subtilis*. *J Bacteriol* **178**:3803-8.
82. **Lambden, P. R., and J. R. Guest.** 1976. Mutants of *Escherichia coli* K12 unable to use fumarate as an anaerobic electron acceptor. *J Gen Microbiol* **97**:145-60.
83. **Larsson, J. T., A. Rogstam, and C. von Wachenfeldt.** 2005. Coordinated patterns of cytochrome *bd* and lactate dehydrogenase expression in *Bacillus subtilis*. *Microbiology* **151**:3323-35.
84. **Liu, X., and P. De Wulf.** 2004. Probing the ArcA-P modulon of *Escherichia coli* by whole genome



- transcriptional analysis and sequence recognition profiling. *J Biol Chem* **279**:12588-97.
85. **Lois, A. F., M. Weinstein, G. S. Ditta, and D. R. Helinski.** 1993. Autophosphorylation and phosphatase activities of the oxygen-sensing protein FixL of *Rhizobium meliloti* are coordinately regulated by oxygen. *J Biol Chem* **268**:4370-5.
86. **Lynch, A. S., and E. C. C. Lin.** 1996. Responses to Molecular Oxygen, p. 1526-1538. In F. C. Neidhardt (ed.), *Escherichia coli* and *Salmonella*: Cellular and Molecular Biology, 2nd ed. vol. I. ASM Press, Washington D.C.
87. **Malpica, R., B. Franco, C. Rodriguez, O. Kwon, and D. Georgellis.** 2004. Identification of a quinone-sensitive redox switch in the ArcB sensor kinase. *Proc Natl Acad Sci U S A* **101**:13118-23.
88. **Manson, M. D., P. Tedesco, H. C. Berg, F. M. Harold, and C. Van der Drift.** 1977. A protonmotive force drives bacterial flagella. *Proc Natl Acad Sci U S A* **74**:3060-4.
89. **Marino, M., T. Hoffmann, R. Schmid, H. Mobitz, and D. Jahn.** 2000. Changes in protein synthesis during the adaptation of *Bacillus subtilis* to anaerobic growth conditions. *Microbiology* **146**:97-105.
90. **Marino, M., H. C. Ramos, T. Hoffmann, P. Glaser, and D. Jahn.** 2001. Modulation of anaerobic energy metabolism of *Bacillus subtilis* by *arfM* (*ywiD*). *J Bacteriol* **183**:6815-21.
91. **Martinez-Argudo, I., R. Little, N. Shearer, P. Johnson, and R. Dixon.** 2004. The NifL-NifA System: a multidomain transcriptional regulatory complex that integrates environmental signals. *J Bacteriol* **186**:601-10.
92. **Masuda, S., and C. E. Bauer.** 2002. AppA is a blue light photoreceptor that antirepresses photosynthesis gene expression in *Rhodobacter sphaeroides*. *Cell* **110**:613-23.
93. **Meijer, W. J., and M. Salas.** 2004. Relevance of UP elements for three strong *Bacillus subtilis* phage phi29 promoters. *Nucleic Acids Res* **32**:1166-76.
94. **Membrillo-Hernandez, J., M. D. Coopamah, A. Channa, M. N. Hughes, and R. K. Poole.** 1998. A novel mechanism for upregulation of the *Escherichia coli* K-12 *hmp* (flavo-haemoglobin) gene by the 'NO releaser', S-nitrosoglutathione: nitrosation of homocysteine and modulation of MetR binding to the *glyA-hmp* intergenic region. *Mol Microbiol* **29**:1101-12.
95. **Milani, M., A. Pesce, H. Ouellet, M. Guertin, and M. Bolognesi.** 2003. Truncated hemoglobins and nitric oxide action. *IUBMB Life* **55**:623-7.
96. **Mitchell, P.** 1961. Coupling of phosphorylation to electron and hydrogen transfer by a chemi-osmotic type of mechanism. *Nature* **191**:144-8.
97. **Moens, L., J. Vanfleteren, Y. Van de Peer, K. Peeters, O. Kapp, J. Czeluzniak, M. Goodman, M. Blaxter, and S. Vinogradov.** 1996. Globins in nonvertebrate species: dispersal by horizontal gene transfer and evolution of the structure-function relationships. *Mol Biol Evol* **13**:324-33.
98. **Moore, M. D., and S. Kaplan.** 1989. Construction of TnphoA gene fusions in *Rhodobacter sphaeroides*: isolation and characterization of a respiratory mutant unable to utilize dimethyl sulfoxide as a terminal electron acceptor during anaerobic growth in the dark on glucose. *J Bacteriol* **171**:4385-94.
99. **Mostertz, J., C. Scharf, M. Hecker, and G. Homuth.** 2004. Transcriptome and proteome analysis of *Bacillus subtilis* gene expression in response to superoxide and peroxide stress. *Microbiology* **150**:497-512.
100. **Nakano, M. M., Y. P. Dailly, P. Zuber, and D. P. Clark.** 1997. Characterization of anaerobic fermentative growth of *Bacillus subtilis*: identification of fermentation end products and genes required for growth. *J Bacteriol* **179**:6749-55.
101. **Nakano, M. M., F. Hajarizadeh, Y. Zhu, and P. Zuber.** 2001. Loss-of-function mutations in *yjbD* result in ClpX- and ClpP-independent competence development of *Bacillus subtilis*. *Mol Microbiol* **42**:383-94.
102. **Nakano, M. M., T. Hoffmann, Y. Zhu, and D. Jahn.** 1998. Nitrogen and oxygen regulation of *Bacillus subtilis* *nasDEF* encoding NADH-dependent nitrite reductase by TnrA and ResDE. *J Bacteriol* **180**:5344-50.
103. **Nakano, M. M., S. Nakano, and P. Zuber.** 2002. Spx (YjbD), a negative effector of competence in *Bacillus subtilis*, enhances ClpC-MecA-ComK interaction. *Mol Microbiol* **44**:1341-9.
104. **Nakano, M. M., and P. Zuber.** 1998. Anaerobic growth of a "strict aerobe" (*Bacillus subtilis*). *Annu Rev Microbiol* **52**:165-90.
105. **Nakano, M. M., P. Zuber, P. Glaser, A. Danchin, and F. M. Hulett.** 1996. Two-component regulatory proteins ResD-ResE are required for transcriptional activation of *fnr* upon oxygen limitation in *Bacillus subtilis*. *J Bacteriol* **178**:3796-802.
106. **Nakano, S., E. Kuster-Schock, A. D. Grossman, and P. Zuber.** 2003. Spx-dependent global transcriptional control is induced by thiol-specific oxidative stress in *Bacillus subtilis*. *Proc Natl Acad Sci U S A* **100**:13603-8.
107. **Nakano, S., M. M. Nakano, Y. Zhang, M. Leelakriangsak, and P. Zuber.** 2003. A regulatory protein that interferes with activator-stimulated transcription in bacteria. *Proc Natl Acad Sci U S A* **100**:4233-8.
108. **Nakano, S., G. Zheng, M. M. Nakano, and P. Zuber.** 2002. Multiple pathways of Spx (YjbD) proteolysis in *Bacillus subtilis*. *J Bacteriol* **184**:3664-70.
109. **Nardini, M., S. Spano, C. Cericola, A. Pesce, A. Massaro, E. Millo, A. Luini, D. Corda, and M. Bolognesi.** 2003. CtBP/BARS: a dual-function protein involved in transcription co-repression and Golgi membrane fission. *Embo J* **22**:3122-30.
110. **Nathan, C. F., and J. B. Hibbs, Jr.** 1991. Role of nitric oxide synthesis in macrophage antimicrobial activity. *Curr Opin Immunol* **3**:65-70.

111. Neidhardt, F. C., and R. Curtiss. 1996. *Escherichia coli* and *Salmonella*: Cellular and Molecular Biology, 2nd ed, vol. I. ASM Press, Washington D.C.
112. Oh, J. I., and S. Kaplan. 2000. Redox signaling: globalization of gene expression. *EMBO J* **19**:4237-47.
113. Ouellet, H., Y. Ouellet, C. Richard, M. Labarre, B. Wittenberg, J. Wittenberg, and M. Guertin. 2002. Truncated hemoglobin HbN protects *Mycobacterium bovis* from nitric oxide. *Proc Natl Acad Sci U S A* **99**:5902-7.
114. Pandini, A., and L. Bonati. 2005. Conservation and specialization in PAS domain dynamics. *Protein Eng Des Sel* **18**:127-37.
115. Park, H., C. Suquet, J. D. Satterlee, and C. Kang. 2004. Insights into signal transduction involving PAS domain oxygen-sensing heme proteins from the X-ray crystal structure of *Escherichia coli* Dos heme domain (Ec DosH). *Biochemistry* **43**:2738-46.
116. Pathania, R., N. K. Navani, A. M. Gardner, P. R. Gardner, and K. L. Dikshit. 2002. Nitric oxide scavenging and detoxification by the *Mycobacterium tuberculosis* haemoglobin, HbN in *Escherichia coli*. *Mol Microbiol* **45**:1303-14.
117. Patschowski, T., D. M. Bates, and P. J. Kiley. 2000. Mechanism for Sensing and Responding to Oxygen Deprivation, p. 61-78. In G. Storz and R. Hengge-Aronis (ed.), *Bacterial stress responses*. ASM Press, Washington, D.C.
118. Perez-Martin, J., F. Rojo, and V. de Lorenzo. 1994. Promoters responsive to DNA bending: a common theme in prokaryotic gene expression. *Microbiol Rev* **58**:268-90.
119. Petersohn, A., M. Brigulla, S. Haas, J. D. Hoheisel, U. Völker, and M. Hecker. 2001. Global analysis of the general stress response of *Bacillus subtilis*. *J Bacteriol* **183**:5617-31.
120. Poole, R. K. 2005. Nitric oxide and nitrosative stress tolerance in bacteria. *Biochem Soc Trans* **33**:176-80.
121. Poole, R. K., M. F. Anjum, J. Membrillo-Hernandez, S. O. Kim, M. N. Hughes, and V. Stewart. 1996. Nitric oxide, nitrite, and Fnr regulation of *hmp* (flavo-hemoglobin) gene expression in *Escherichia coli* K-12. *J Bacteriol* **178**:5487-92.
122. Poole, R. K., and M. N. Hughes. 2000. New functions for the ancient globin family: bacterial responses to nitric oxide and nitrosative stress. *Mol Microbiol* **36**:775-83.
123. Popescu, C. V., D. M. Bates, H. Beinert, E. Munck, and P. J. Kiley. 1998. Mossbauer spectroscopy as a tool for the study of activation/inactivation of the transcription regulator FNR in whole cells of *Escherichia coli*. *Proc Natl Acad Sci U S A* **95**:13431-5.
124. Price, C. W., P. Fawcett, H. Ceremonie, N. Su, C. K. Murphy, and P. Youngman. 2001. Genome-wide analysis of the general stress response in *Bacillus subtilis*. *Mol Microbiol* **41**:757-74.
125. Rice, C. W., and W. P. Hempfling. 1978. Oxygen-limited continuous culture and respiratory energy conservation in *Escherichia coli*. *J Bacteriol* **134**:115-24.
126. Ross, P., R. Mayer, H. Weinhouse, D. Amikam, Y. Huggirat, M. Benziman, E. de Vroom, A. Fidler, P. de Paus, L. A. Sliedregt, et al. 1990. The cyclic diguanylic acid regulatory system of cellulose synthesis in *Acetobacter xylinum*. Chemical synthesis and biological activity of cyclic nucleotide dimer, trimer, and phosphothioate derivatives. *J Biol Chem* **265**:18933-43.
127. Salgado, H., S. Gama-Castro, A. Martinez-Antonio, E. Diaz-Peredo, F. Sanchez-Solano, M. Peralta-Gil, D. Garcia-Alonso, V. Jimenez-Jacinto, A. Santos-Zavaleta, C. Bonavides-Martinez, and J. Collado-Vides. 2004. RegulonDB (version 4.0): transcriptional regulation, operon organization and growth conditions in *Escherichia coli* K-12. *Nucleic Acids Res* **32**:D303-6.
128. Salmon, K., S. P. Hung, K. Mekjian, P. Baldi, G. W. Hatfield, and R. P. Gunsalus. 2003. Global gene expression profiling in *Escherichia coli* K12. The effects of oxygen availability and FNR. *J Biol Chem* **278**:29837-55.
129. Salmon, K. A., S. P. Hung, N. R. Steffen, R. Krupp, P. Baldi, G. W. Hatfield, and R. P. Gunsalus. 2005. Global gene expression profiling in *Escherichia coli* K12: effects of oxygen availability and Arca. *J Biol Chem* **280**:15084-96.
130. Saraste, M. 1999. Oxidative phosphorylation at the *fin de siecle*. *Science* **283**:1488-93.
131. Sasakura, Y., S. Hirata, S. Sugiyama, S. Suzuki, S. Taguchi, M. Watanabe, T. Matsui, I. Sagami, and T. Shimizu. 2002. Characterization of a direct oxygen sensor heme protein from *Escherichia coli*. Effects of the heme redox states and mutations at the heme-binding site on catalysis and structure. *J Biol Chem* **277**:23821-7.
132. Schau, M., Y. Chen, and F. M. Hulett. 2004. *Bacillus subtilis* YdiH is a direct negative regulator of the *cydABCD* operon. *J Bacteriol* **186**:4585-95.
133. Shindyalov, I. N., and P. E. Bourne. 1998. Protein structure alignment by incremental combinatorial extension (CE) of the optimal path. *Protein Eng* **11**:739-47.
134. Sickmier, E. A., D. Brekasis, S. Paranawithana, J. B. Bonanno, M. S. Paget, S. K. Burley, and C. L. Kielkopf. 2005. X-ray structure of a Rex-family repressor/NADH complex insights into the mechanism of redox sensing. *Structure (Camb)* **13**:43-54.
135. Spizizen, J. 1958. Transformation of biochemically deficient strains of *Bacillus subtilis* by deoxyribonucleate. *Proc. Natl. Acad. Sci. USA* **44**:5463-5467.
136. Stadtman, E. R. 1993. Oxidation of free amino acids and amino acid residues in proteins by radiolysis and by metal-catalyzed reactions. *Annu Rev Biochem* **62**:797-821.



137. **Stamler, J. S., D. J. Singel, and J. Loscalzo.** 1992. Biochemistry of nitric oxide and its redox-activated forms. *Science* **258**:1898-902.
138. **Stewart, V.** 1988. Nitrate respiration in relation to facultative metabolism in enterobacteria. *Microbiol Rev* **52**:190-232.
139. **Strick, J. E.** 2000. Sparks of Life - Darwinism and the Victorian Debates over Spontaneous Generation. Harvard University Press, Cambridge.
140. **Sun, G., E. Sharkova, R. Chesnut, S. Birkey, M. F. Duggan, A. Sorokin, P. Pujic, S. D. Ehrlich, and F. M. Hulett.** 1996. Regulators of aerobic and anaerobic respiration in *Bacillus subtilis*. *J Bacteriol* **178**:1374-85.
141. **Swem, D. L., and C. E. Bauer.** 2002. Coordination of ubiquinol oxidase and cytochrome *cbb5* oxidase expression by multiple regulators in *Rhodobacter capsulatus*. *J Bacteriol* **184**:2815-20.
142. **Taylor, B. L., I. B. Zhulin, and M. S. Johnson.** 1999. Aerotaxis and other energy-sensing behavior in bacteria. *Annu Rev Microbiol* **53**:103-28.
143. **Tseng, C. P., J. Albrecht, and R. P. Gunsalus.** 1996. Effect of microaerophilic cell growth conditions on expression of the aerobic (*cyoABCDE* and *cydAB*) and anaerobic (*narGHJI*, *frdABCD*, and *dmsABC*) respiratory pathway genes in *Escherichia coli*. *J Bacteriol* **178**:1094-8.
144. **Tuckerman, J. R., G. Gonzalez, E. M. Dioum, and M. A. Gilles-Gonzalez.** 2002. Ligand and oxidation-state specific regulation of the heme-based oxygen sensor FixL from *Sinorhizobium meliloti*. *Biochemistry* **41**:6170-7.
145. **Uندن, G., and J. Bongaerts.** 1997. Alternative respiratory pathways of *Escherichia coli*: energetics and transcriptional regulation in response to electron acceptors. *Biochim Biophys Acta* **1320**:217-34.
146. **van Keulen, G., L. Girbal, E. R. van den Bergh, L. Dijkhuizen, and W. G. Meijer.** 1998. The LysR-type transcriptional regulator CbbR controlling autotrophic CO₂ fixation by *Xanthobacter flavus* is an NADPH sensor. *J Bacteriol* **180**:1411-7.
147. **van Leewenhoek, A.** 1677. Observations, Communicated to the Publisher by Mr. Antony van Leewenhoek, in a Dutch Letter of the 9th of Octob. 1676. Here English'd: concerning Little Animals by Him Observed in Rain-Well- Sea- and Snow-Water; as Also in Water Wherein Pepper Had Lain Infused. *Philosophical Transactions (1665-1678)* **12**:pp. 821-831.
148. **Wink, D. A., and J. B. Mitchell.** 1998. Chemical biology of nitric oxide: Insights into regulatory, cytotoxic, and cytoprotective mechanisms of nitric oxide. *Free Radic Biol Med* **25**:434-56.
149. **Winstedt, L., K. Yoshida, Y. Fujita, and C. von Wachenfeldt.** 1998. Cytochrome *bd* biosynthesis in *Bacillus subtilis*: characterization of the *cydABCD* operon. *J Bacteriol* **180**:6571-80.
150. **Wittenberg, J. B., M. Bolognesi, B. A. Wittenberg, and M. Guertin.** 2002. Truncated hemoglobins: a new family of hemoglobins widely distributed in bacteria, unicellular eukaryotes, and plants. *J Biol Chem* **277**:871-4.
151. **Wolf, S. G., D. Frenkiel, T. Arad, S. E. Finkel, R. Kolter, and A. Minsky.** 1999. DNA protection by stress-induced biocrystallization. *Nature* **400**:83-5.
152. **Wu, G., L. M. Wainwright, and R. K. Poole.** 2003. Microbial globins. *Adv Microb Physiol* **47**:255-310.
153. **Zeilstra-Ryalls, J. H., and S. Kaplan.** 2004. Oxygen intervention in the regulation of gene expression: the photosynthetic bacterial paradigm. *Cell Mol Life Sci* **61**:417-36.
154. **Zellmeier, S., U. Zuber, W. Schumann, and T. Wiegert.** 2003. The absence of FtsH metalloprotease activity causes overexpression of the sigmaW-controlled *phpE* gene, resulting in filamentous growth of *Bacillus subtilis*. *J Bacteriol* **185**:973-82.
155. **Zhang, Q., D. W. Piston, and R. H. Goodman.** 2002. Regulation of corepressor function by nuclear NADH. *Science* **295**:1895-7.
156. **Zhao, G., P. Ceci, A. Ilari, L. Giangiaco, T. M. Laue, E. Chiancone, and N. D. Chasteen.** 2002. Iron and hydrogen peroxide detoxification properties of DNA-binding protein from starved cells. A ferritin-like DNA-binding protein of *Escherichia coli*. *J Biol Chem* **277**:27689-96.
157. **Zheng, M., F. Åslund, and G. Storz.** 1998. Activation of the OxyR transcription factor by reversible disulfide bond formation. *Science* **279**:1718-21.
158. **Zhulin, I. B., B. L. Taylor, and R. Dixon.** 1997. PAS domain S-boxes in Archaea, Bacteria and sensors for oxygen and redox. *Trends Biochem Sci* **22**:331-3.
159. **Åslund, F., M. Zheng, J. Beckwith, and G. Storz.** 1999. Regulation of the OxyR transcription factor by hydrogen peroxide and the cellular thiol-disulfide status. *Proc Natl Acad Sci U S A* **96**:6161-5.

