



LUND UNIVERSITY

Study on Combustion Chamber Geometry Effects in an HCCI Engine using High-Speed Cycle-Resolved Chemiluminescence Imaging

Vressner, Andreas; Hultqvist, Anders; Johansson, Bengt

2007

[Link to publication](#)

Citation for published version (APA):

Vressner, A., Hultqvist, A., & Johansson, B. (2007). *Study on Combustion Chamber Geometry Effects in an HCCI Engine using High-Speed Cycle-Resolved Chemiluminescence Imaging*. (SAE Technical Paper Series). <http://www.sae.org/technical/papers/2007-01-0217>

Total number of authors:

3

General rights

Unless other specific re-use rights are stated the following general rights apply:

Copyright and moral rights for the publications made accessible in the public portal are retained by the authors and/or other copyright owners and it is a condition of accessing publications that users recognise and abide by the legal requirements associated with these rights.

- Users may download and print one copy of any publication from the public portal for the purpose of private study or research.
- You may not further distribute the material or use it for any profit-making activity or commercial gain
- You may freely distribute the URL identifying the publication in the public portal

Read more about Creative commons licenses: <https://creativecommons.org/licenses/>

Take down policy

If you believe that this document breaches copyright please contact us providing details, and we will remove access to the work immediately and investigate your claim.

LUND UNIVERSITY

PO Box 117
221 00 Lund
+46 46-222 00 00

Study on Combustion Chamber Geometry Effects in an HCCI Engine using High-Speed Cycle-Resolved Chemiluminescence Imaging

Andreas Vressner, Anders Hultqvist and Bengt Johansson
Division of Combustion Engines, Lund University

Copyright © 2006 SAE International

ABSTRACT

The aim of this study is to see how geometry generated turbulence affects the Rate of Heat Release (ROHR) in an HCCI engine. HCCI combustion is limited in load due to high peak pressures and too fast combustion. If the speed of combustion can be decreased the load range can be extended. Therefore two different combustion chamber geometries were investigated, one with a disc shape and one with a square bowl in piston. The later one provokes squish-generated gas flow into the bowl causing turbulence. The disc shaped combustion chamber was used as a reference case. Combustion duration and ROHR were studied using heat release analysis. A Scania D12 Diesel engine, converted to port injected HCCI with ethanol was used for the experiments. An engine speed of 1200 rpm was applied throughout the tests. The effect of air/fuel ratio and combustion phasing was also studied. The behavior of the heat release was correlated with high speed chemiluminescence imaging for both combustion chamber geometries. Optical access was enabled from beneath by a quartz piston and a 45 degree mirror. It was found that the square bowl in piston generates higher turbulence levels resulting in half the ROHR and twice as long combustion duration as the disc shaped combustion chamber. By using a resolution of 3 images per CAD, the fast gas movements during the entire HCCI combustion process could be studied inside the bowl.

INTRODUCTION

Homogeneous Charge Compression Ignition (HCCI) engines are well known for high efficiency and low emissions of Nitrogen Oxides (NO_x) and particulate matter [1, 2]. One of the negative issues with HCCI is how to control the combustion phasing since it mostly depends on the pressure and temperature history of the cycle. If the load is too high and/or the combustion timing is too advanced the combustion rates will be very high and thus also the pressure rise rates which not only causes excessive noise but also could lead to engine

damage. Ways of decreasing the combustion rates are for example dilution with Exhaust Gas Recirculation (EGR) which slows down the reaction rates. Another approach could be to change the flow conditions in the cylinder. This can be done using Variable Valve Actuation (VVA) with valve timings set in such a way that different amount of swirl is provoked inside in the combustion chamber. An alternative is geometry-generated turbulence which has been studied in this paper, where piston geometry in the form of a square bowl in piston with a narrow squish region forces the gas down into the bowl causing turbulent conditions.

PRIOR WORK

The effect of geometry generated turbulence on Rate of Heat Release (ROHR) has been studied in earlier work by Christensen et. al. [3, 4]. It was found that the ROHR could be decreased by about 50% and the combustion duration doubled by the use of a bowl compared to a disc shaped combustion chamber during similar operating conditions. This means that the load can be increased by the use of bowl geometries with acceptable pressure rise rates. The penalty was lower efficiency for late combustion phasing in the bowl case. The turbulence level was measured by Laser Doppler Velocimetry (LDV) and found to be twice as high at Top Dead Centre (TDC) with the bowl geometry. However it was not clear if the decreased ROHR was entirely due to turbulence effects or due to other effects caused by the geometry. Therefore it is appropriate to separate the conditions caused by the geometry into direct and indirect effects:

1. Direct effects could be the turbulence effect on chemical kinetics.
2. Indirect effects are for example boundary layer thickness, temperature distribution, heat losses and charge homogeneity.

Kong et. Al. [5], modeled the direct effect of turbulent flow on chemical kinetics by the eddy breakup concept

using CFD with detailed chemical kinetics code. The model predicted the longer combustion duration in the bowl case due to increased wall heat transfer, but more comprehensive CFD models are needed to predict turbulence and heat transfer accurately.

Another theory for explaining the decreased ROHR and increased combustion duration could be that the geometry causes a sort of 2-stage combustion where the ignition first occurs in the bottom of the bowl where the hot residuals probably are located and as time proceeds the combustion propagates out into the squish volume during the early stages of the expansion stroke. This would probably be due to charge stratification in either temperature, air/fuel ratio or a combination of both. In the disc shaped combustion chamber the temperature distribution is expected to be more even as the residuals would be better mixed with the fresh charge. In contradiction to this one might argue that the high turbulence found in the bowl case should result in even better mixing compared to the disc geometry, resulting in a less stratified charge in terms of air/fuel ratio and temperature. However, at an early stage before the onset of combustion it is reasonable to believe that the residuals are trapped in the bowl.

Recent Planar Laser Induced Fluorescence (PLIF) experiments have shown a homogeneous fuel distribution throughout the bowl. However, stratified combustion behavior was found suggesting an inhomogeneous temperature distribution where hot zones ignites first and propagates into the colder ones resulting in a longer combustion duration compared to a perfectly mixed charge which ignites simultaneously [6]. The PLIF experiments were compared with Large Eddy Simulations (LES) [7] where it was found that the combustion chamber geometry had a large effect on flow, mixing and on the temperature distribution in the charge during the early stages of the intake stroke. The induced temperature in-homogeneities during the intake stroke survive during the compression stroke resulting in a stratified charge which combusts at a lower rate. The explanation to the stratification was found in the in high area to volume ratio in combination with slow gas flow inside the bowl resulting in a heater effect. The strong effects of temperature stratification on HCCI combustion rate with the potential of increasing the maximum load have also been studied by other researchers like Sankaran et al.[8] and Sjöberg et al [9].

PRESENT WORK

The recent LES and PLIF studies have shown a possible explanation for the longer combustion duration which would be due to temperature stratification. However the PLIF experiments are limited to a small area inside the bowl and the LES experiments have to be compared with experiments of a more global nature than the PLIF technique to also include the squish volume. This study applies chemiluminescence imaging in order to find where the combustion starts and ends with the two

combustion chamber geometries. This will allow further insight into the direct and indirect affects of turbulence on HCCI combustion rate.

EXPERIMENTAL APPARATUS

The first thing that should be mentioned is that the engine used in this work is not the same as the one used in Christensens work [3, 4, 5]. He used a Volvo TD100 engine with 2 valves per cylinder while for this study a Scania D12 engine with 4 valves per cylinder was used. The turbulence levels are not expected to be the same between the engines but Christensen's work indicates that by using a bowl geometry the turbulence level is increased compared to a disc shaped combustion chamber.

Engine setup

The engine used in this study was a six cylinder Scania D12 truck sized diesel engine converted to HCCI operation by the use of port fuel injection (PFI). The engine was in single cylinder operation meaning that only one cylinder was operational while the rest were motored. A piezoelectric water-cooled Kistler 7061B pressure transducer was used to monitor the in-cylinder pressure and this information was used to control the phasing of combustion by changing the inlet air temperature with an electrical heater. Some vital engine data can be found in Table 1. The fuel was a mixture of acetone and ethanol with volume ratio of 10/90. The reason for using this fuel was the possibility in the future to compare the results of this study with fuel tracer laser induced fluorescence (LIF) with acetone as fuel tracer.

Table 1. Operating conditions and geometrical data of the Scania D12 Engine.

Displaced volume	1951 cc
Stroke	154 mm
Bore	127 mm
Connecting rod	255 mm
Exhaust valve open	82° BBDC (@ 0.15 mm lift)
Exhaust valve close	38° ATDC (@ 0.15 mm lift)
Inlet valve open	39° BTDC (@ 0.15 mm lift)
Inlet valve close	63° ABDC (@ 0.15 mm lift)
Valve lift inlet	14 mm
Valve lift exhaust	14 mm
Fuel Injection	PFI
Fuel	Ethanol/Acetone: 90%/10%
Engine Speed	1200 rpm
Intake Pressure	1 Bar Absolute
Intake Temperature	75-125 °C

Combustion Chambers and Optical Access

Two different combustion chambers were tested in this study, one disc shaped combustion chamber and one

with a square bowl in piston. With the disc shaped combustion chamber the swirling motion of the charge is believed to be pretty undisturbed during the compression stroke. This geometry is used as a baseline and reference case to the main object of interest, the square bowl in piston. When using a square bowl combustion chamber with a narrow squish region a strong squish motion forces the swirling motion of the charge into the bowl during the compression stroke creating a turbulent environment, especially in the corners of the bowl.

The engine was equipped with a quartz window in the piston and a 45 degree mirror which enables optical access from beneath. This setup has been used for numerous studies before with the disc shaped combustion chamber. For this geometry the quartz window in the piston is squeezed in between to titanium retainers preventing the window to come off during operation, see Figure 1.

With the square bowl in piston geometry the upper part of the piston was entirely made of quartz glass in order to be able to conduct optical experiments from the side, see photo in Figure 2. This means that the quartz piston could not be mounted in the same way as for the disc geometry. Instead the quartz piston was glued onto a titanium piston crown holder, where the glue is the only thing preventing the quartz piston to come off. A sketch of this geometry can be found in Figure 3. It should also be mentioned that the bowl has equal sides, 47 mm, while the depth is 37.4 mm. The ratio between width and depth is the same as in the Volvo TD100 experiments.

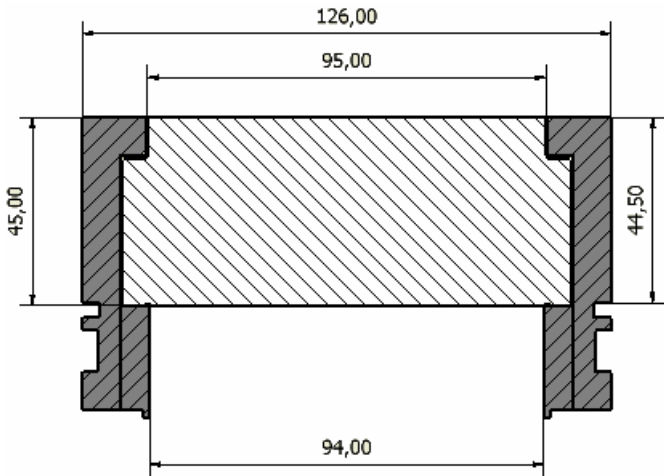

Figure 1. Sketch showing a cross section of the disc piston with the most important dimensions. White area is quartz and gray is titanium. All dimensions in mm.

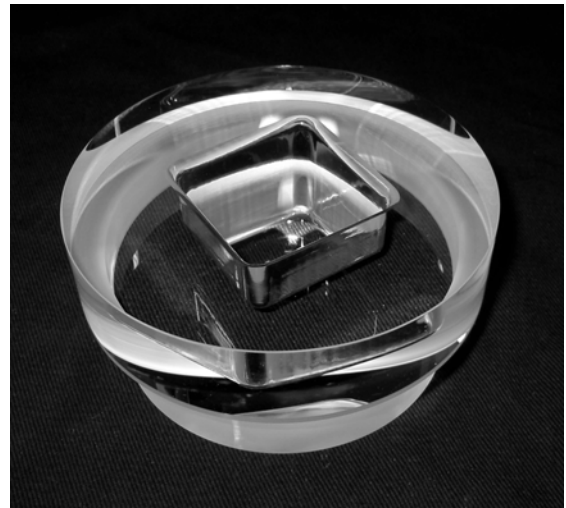

Figure 2. Picture of the quartz piston with the square bowl.

Some geometrical properties of the two combustion chambers can be found in Table 2. Due to expansion of the piston extension and the glue caused by elevated temperatures and mass forces, especially at gas exchange TDC, the squish distance in the bowl case was increased to 1.75 mm compared to 1mm which was used in the Volvo TD100 engine. Still the squish motion is believed to be strong enough to generate turbulence in the bowl.

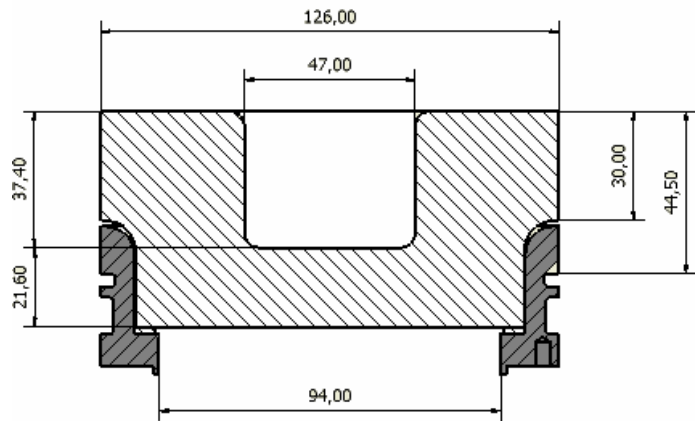

Figure 3. Sketch showing a cross section of the square bowl in piston with the most important dimensions. White area is quartz and gray is titanium. All dimensions in mm.

Table 2. Geometric properties of the combustion chambers used.

	Disc	Bowl
CR	17.2:1	17.2:1
Squish Distance	8.15 mm	1.75 mm
Topland Height	44.5 mm	44.5 mm
Wall Area at TDC	288 cm ²	333 cm ²

From Table 2 it can also be seen that the topland height is quite high for both geometries. This is due to optical access limiting the possibility to mount the piston rings as high as would be preferred. Since a large topland volume will trap fuel which is released when the pressure drops during the expansion stroke the combustion efficiency is expected to drop a few units [10]. However the most important thing is that the topland height is the same for both geometries.

Chemiluminescence Imaging

The high speed camera used for retrieving chemiluminescence images was a *Phantom v7.1* from *Vision Research*. A *Hamamatsu* high speed image intensifier was also used. The temporal resolution was 21.6 kHz which corresponds to 3 images per Crank Angle Degree (CAD) at an engine speed of 1200 rpm. This engine speed was used during the entire study. For both combustion chamber geometries investigated a *Nikkor 50mm f1.2* lens system was used. Since the lenses are made of glass and no filters were used, only light in the visible region was detected. This means that light in the UV region (<400nm) was not captured by the camera. Previous studies have shown that the spectrum of the main heat release in HCCI combustion ranges from about 250nm to 550nm [11, 12]. Therefore species like OH* are probably not detected but the main contributors to the emitted light in the visible region are believed to be CH*, HCO*, CO₂*, CH₂O* and CO continuum. Due to the nearly homogeneous charge in HCCI engines, soot emissions are low which results in less emission of light from C₂* which is believed to be a precursor of soot.

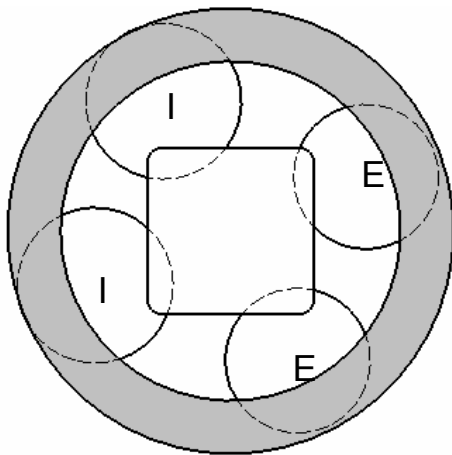

Figure 4. Drawing of the field of view from beneath where the white part is the visible area. "I" denotes Intake valves and "E" denotes Exhaust valves.

The spatial resolution was set to 288 x 296 pixels. The camera was focused in such way that the pixels where used as efficiently as possible related to the field of view. The field of view through the mirror can be seen in Figure 4 for the bowl case. The field of view for the disc

case is similar except for the square denoting the bowl. This figure can be used to compare the location where the combustion starts in the chemiluminescence images with the locations of the valves.

RESULTS

HEAT RELEASE ANALYSIS

Figure 5 shows the operating points studied with the different combustion chamber geometries. Ten operational points were tested for the bowl geometry (star) while six points were tested for the disc geometry (circle). The reason for not running all ten points with disc geometry was the steep pressure rise rate which could lead to damage of the fragile quartz window. The pressure rise rate for the bowl case was much lower which enabled higher load or advance combustion phasing. From a pressure rise rate point of view the load could have been increased even further with the bowl geometry but the authors choose not to in order to protect the expensive quartz piston.

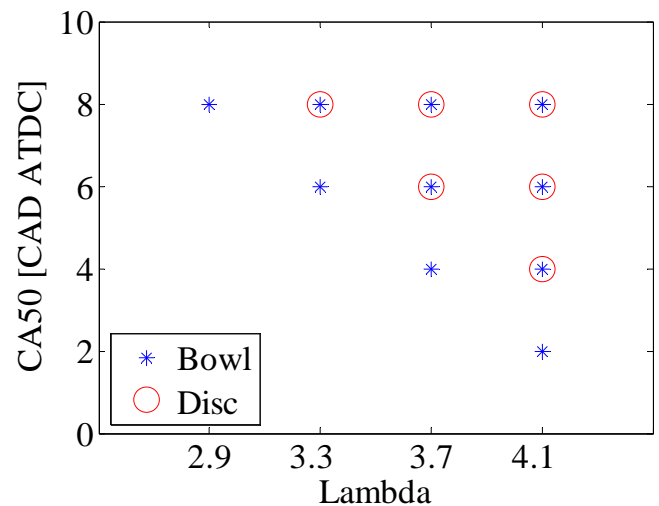

Figure 5. Operational points for both geometries. Star denotes Bowl and circle denotes Disc.

In Figure 6 in-cylinder pressure and ROHR traces can be found for both the disc and bowl geometry. The operating conditions correspond to the highest load case achieved with disc, see Figure 5, i.e. a λ -value of 3.3 and CA50 of 8 CAD ATDC. Further information about this load point is found in Table 3. It can be seen that both ROHR and pressure rise during combustion are much lower for the bowl case compared to the disc case. The pressure rise rate in the disc case is 2.73 Bar/CAD while in the bowl case the pressure rise rate is only 1 Bar/CAD which is a substantial difference in stress on the engine components. The emission of noise is also significantly lower using the bowl combustion chamber for this operating point.

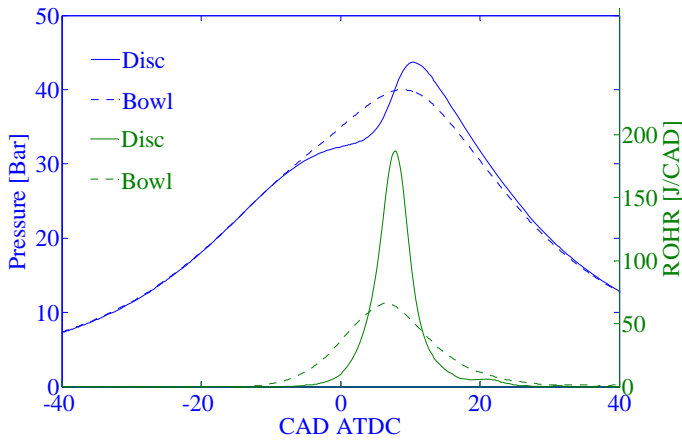

Figure 6. In-cylinder pressure and ROHR as function of CAD for both disc and bowl combustion chambers.

Table 3. Operating conditions for the highest load point achieved with the disc geometry.

	Disc	Bowl
λ	3.3	3.3
CA50 [CAD ATDC]	8	8
IMEP [Bar]	2.81	2.79
T_{intake} [°C]	127	95
CA10-CA90 [CAD]	8.2	17.6
dP [Bar/CAD]	2.73	1.00

CHEMILUMINESCENCE IMAGING

In Figure 7, single cycle chemiluminescence images can be found for the disc geometry corresponding to the operating conditions found in Table 3. The engine speed was 1200 rpm with a λ value of 3.3 and combustion phasing in terms of CA50 of 8 CAD ATDC. The intensity in the images is scaled so that the highest intensity in each image is close to saturated, i.e. appears white. This is done in order to see where the combustion starts which otherwise would not be visible in the early and late stages of combustion. For this cycle the combustion starts in the left corner of the images and propagates around the perimeter and in the end the charge in the centre is combusted. Since the field of view only covers 51% of the combustion chamber it is most likely that the combustion starts close to the walls and propagates to the centre of the combustion chamber. This has been seen in other optical studies in the Scania engine [11]. The intensity appears near TDC and expands slowly in the beginning. At 7 CADs ATDC the combustion speeds up and at 12 CAD ATDC and on the intensity begins to fade away.

In Figure 8 chemiluminescence images for the bowl case can be found for the same load case as the disc case in Figure 7. The combustion starts much earlier in the bowl case even though the combustion phasing in terms of CA50 is the same, 8 CAD ATDC. The intensity first appears in the upper right corner of the bowl. The gradient between the burnt and unburnt zone is sharp suggesting a stratification in either temperature or air/fuel ratio. This behavior can also be seen for the disc case in Figure 7, but the gradients are not as sharp as in the bowl case. As the combustion proceeds the intensity appears along the upper wall of the bowl in Figure 8 and as the piston reaches TDC the combustion speeds up and intensity appears both along the left and lower walls and also in the bulk of the combustion chamber. Some 10 CADs ATDC there is still signal along the walls in the bowl but also in the squish region outside the bowl. The signal disappears 20 CAD ATDC suggesting long combustion duration compared to the disc case.

In the bowl case combustion starts just below one of the exhaust valves which could indicate that auto ignition is triggered by heat transfer from the hot valve. Another explanation could be that the turbulence level is such that the conditions are the best for ignition in this region. It could also be due to stratification in air/fuel ratio meaning that the mixture is richer in that corner which would suggest that it is more prone to ignite.

CHEMILUMINESCENCE INTENSITY AND ROHR CORRELATION

It is of interest to compare the appearance of intensity with ROHR over CAD between the two geometries since the combustion speed is so different. In Figure 9 this comparison can be found for the disc case. The correlation is good between the appearance of intensity and ROHR as also seen in other studies [11 - 14]. However a few CADs before TDC there is heat release but no intensity. It is not until after TDC that intensity and heat release are present at the same time. This is most likely due to the limitation in field of view disabling the possibility of collecting light from near wall combustion. Another possible cause, although not as likely, is that the light per area unit is so small that the camera could not detect it. In the end of combustion, 15 CAD ATDC, no intensity can be found but there is still a tail of heat release. This tail in the heat release trace is pretty common when dealing with combustion chambers with large topland volumes [10]. The unburned fuel trapped in the topland volume is flowing out in the main combustion chamber as the pressure decreases during the expansion stroke and is then oxidized leading to heat release. It is likely that this is happening close to the cylinder walls near the edge of the piston which is outside the field of view. This explains the lack of intensity in the images during the after-oxidation of the trapped fuel from the topland volume.

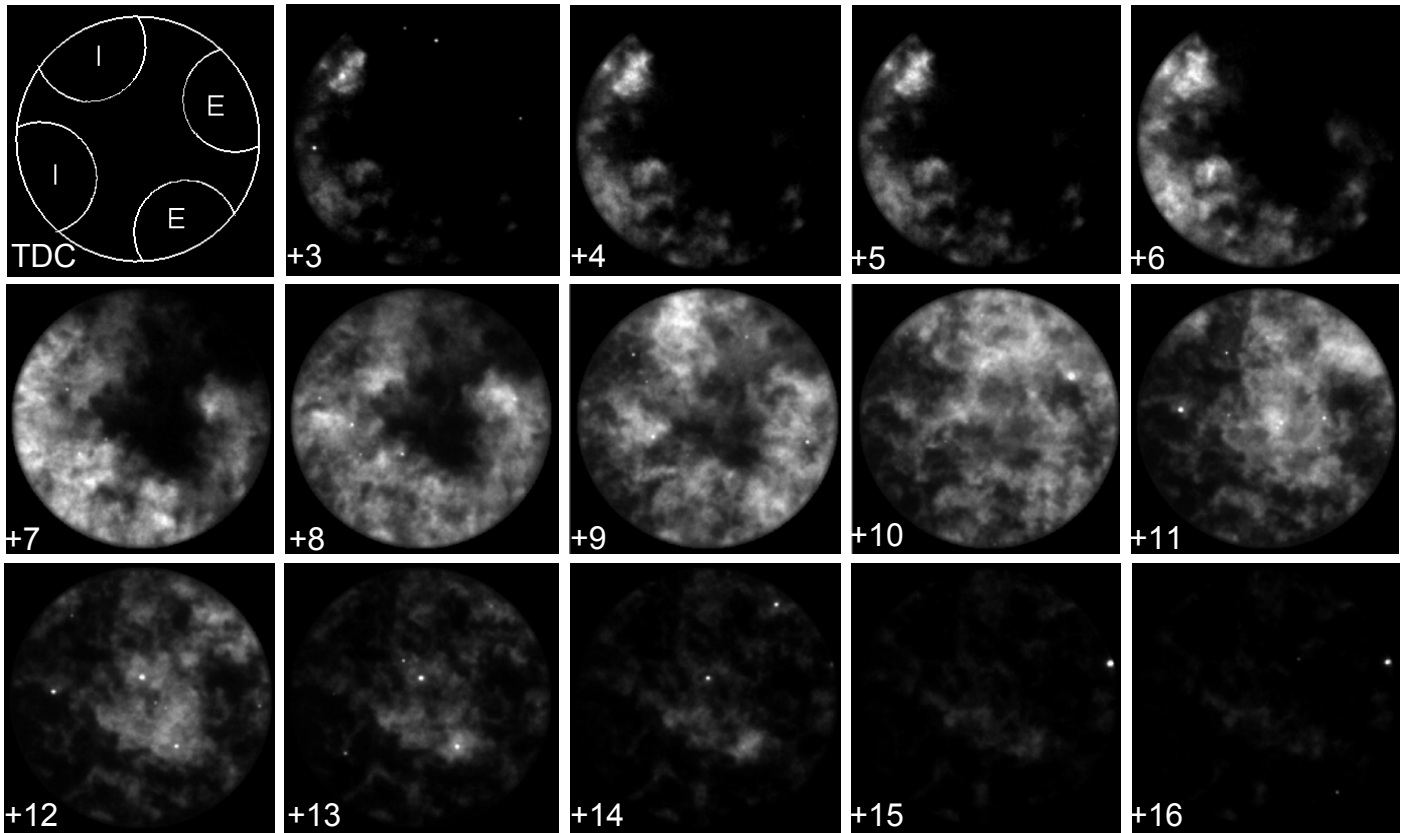

Figure 7. Single cycle chemiluminescence images for the disc case. $\lambda = 3.3$ and CA50 = 8 CAD ATDC.

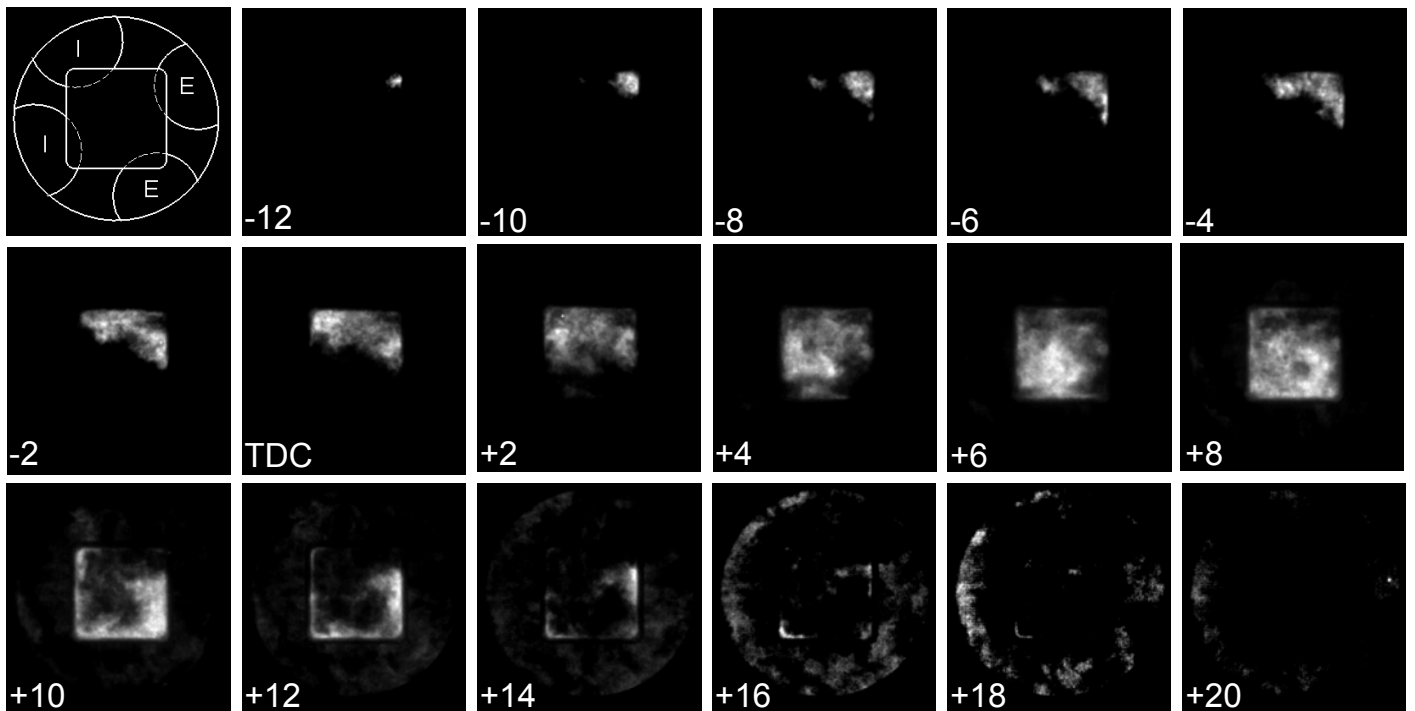

Figure 8. Single cycle chemiluminescence images for the bowl case. $\lambda = 3.3$ and CA50 = 8 CAD ATDC.

In Figure 10 intensity and ROHR are plotted versus crank angle for the bowl case. The intensity trace is divided in three parts, bowl (square), squish (diamond) and the total intensity (circle). The intensity and ROHR is

starting to climb at the same time, probably due to the reactions taking place inside the field of view in combination with the high intensity per unit area. It is also likely that the combustion starts in the bowl where

the hot residuals are most likely located whereas in the disc case the combustion starts closer to the cylinder walls. Since the bowl is visible through the piston window the intensity from this region is seen in the images. Both intensity and ROHR increase slowly until TDC where the combustion speeds up. The early combustion in the bowl behaves like a sharp reaction front propagating through the charge. This suggests that the gas in front of this reaction zone has to be far from reaching auto ignition and the heat from the reaction zone only heats up the gas in close proximity. Therefore the combustion rate is slow at first consuming the charge close to the upper wall in the bowl. At TDC the combustion rate suddenly speeds up consuming the rest of the charge in the bowl in less than 10 CAD. The combustion of the bulk in the bowl is more globally spread like in the disc case with more visible structures. This probably means that the bulk charge had to be heated up by the combustion near the upper wall from first ignition 12 CAD BTDC to TDC. And only, when this was completed most of the bulk charge was close to auto ignition conditions, meaning fairly uniform temperature and air/fuel ratio, resulting in a higher burn rate.

At 5 CAD ATDC intensity starts to appear in the squish. 15 CAD ATDC there is no signal left in the bowl but there is still signal in the squish. As in the disc case there is a tail in the ROHR trace due to the after oxidation of the fuel from the topland volume and since this is not in the visible area it is not seen in the images. The late combustion in the squish could be explained by stratification in temperature. Since the squish volume is so narrow at TDC, heat losses from the gas to the walls are high suggesting that quenching might occur. However if the heat transfer from the burned gas in the bowl can raise the temperature in the squish as the piston starts to move down in the expansion stroke the conditions for autoignition could improve. This might explain the late appearance of intensity in the squish region.

A conclusion that can be drawn from Figure 8 and Figure 10 is that the combustion seems to start inside the bowl and propagates out into the squish. From Figure 10 the accumulated signal in the bowl and squish was calculated separately. It was found that 93% of the total accumulated signal in the field of view was from the bowl and 7% from the squish. The volume in the bowl is 10 times larger than in the squish at TDC. Since the difference in signal level is about the same as the difference in volume between the bowl and the squish, this suggests that the signal per unit volume is roughly the same. Since the chemiluminescence signal is coupled to the heat release [11-14] this indicates that the heat release is about the same in the bowl and squish. If the heat release is the same, the amount of fuel per unit volume is the same, thus the air/fuel equivalence ratio is probably the same. This confirms the previous suspicion that the reason for retarded combustion in the squish compared to the bowl is a difference in charge

temperature instead of differences in air/fuel equivalence ratio. However this estimation is based on some rough assumptions:

1. The gas movements are not fast enough to cause any large species exchanges between the volumes considered.
2. No scatter in light occurs that results in exchange of light between the squish and the bowl.
3. The ratio of emitted light in the ultraviolet (UV) region compared to the visible region is the same. (UV light is not captured by the camera.)
4. The absorption of light in the quartz glass is the same beneath the bowl and the squish.

Even though the estimation above was made on rough assumptions the indication of the stratification being due temperature in-homogeneities and not air/fuel differences in the bowl is supported by the fuel tracer LIF experiments conducted by Seyfried et al.[6] where it was found that the fuel was homogeneously distributed through the combustion chamber.

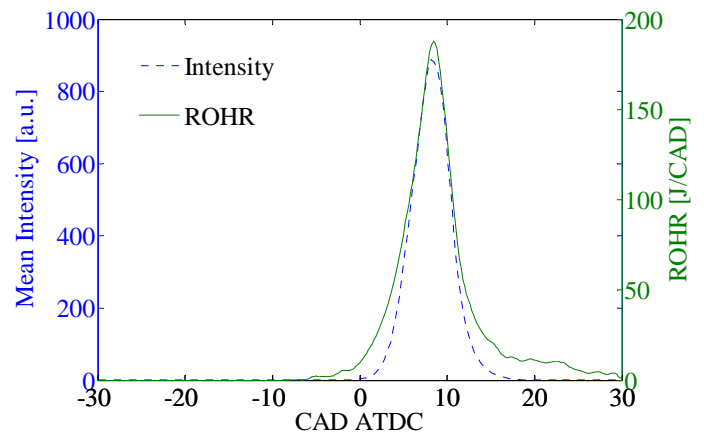

Figure 9. Intensity and ROHR as function of CAD for the disc case.

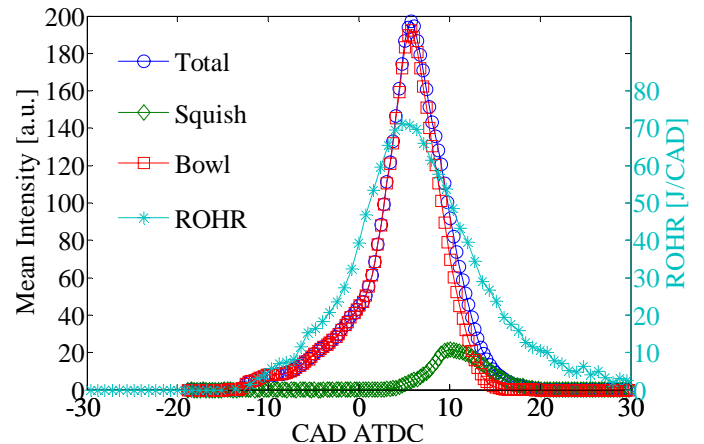

Figure 10. Intensity and ROHR as function of CAD for the Bowl case.

DOES THE COMBUSTION ALWAYS START IN THE SAME LOCATION OF THE BOWL?

It is of interest to know if the combustion always starts in the same corner of the bowl like the single cycle in Figure 8. In Figure 11 images of averaged cycles for four different λ -values can be found. Additionally three different crank angles of mass fraction burned can be seen. The averaging of the images is conducted in the following way. At first the single images have been converted to a binary format with the values 0 for no signal and 1 for signal. Then all 20 images have been summarized resulting in pixel values from 0 to 20. Lastly four different grayscale images have been selected to show in how many of the 20 cycles where intensity appears in the different pixels. This means that where the images are black between 0-5% (≤ 1 cycle) of the 20 cycles have signal and so on. The white areas show where the probability of signal is 80% or higher. By presenting the images in this way it can be found for crank angle of 2% burned (CA2) that it is most likely that the combustion starts in the upper right corner of the bowl. This trend is seen for all four λ -values. The light and dark gray areas show that there are some cycle to cycle variations in how much the combustion has propagated from this corner. The images for CA50 show that the combustion at this point has propagated towards the lower side of the bowl and there are no large differences between the images. Lastly at CA90 the combustion has started in the squish volume too. At CA90 for the leanest case there is more combustion in the bowl suggesting that the temperature is not high enough in the squish region for an efficient autoignition.

Since it was suspected that different fractions of heat are released in the bowl for different mixture compositions, the fraction of the total intensity in the images that appear in the bowl was calculated. The result can be found in Figure 12 along with errorbars showing the standard deviation of the result. As seen, 90% of the total intensity in the images appears in the bowl for a λ -value of 2.9. For leaner mixtures more and more of the intensity is found in the bowl, but the difference is not so large. The standard deviation is about the same for all λ -values, around 2%. However it should be stated that the statistical reliability is low since the difference in intensity between different mixture compositions is smaller than the standard deviation. This result implies that for leaner mixtures the temperature in the squish volume is too low to oxidize the fuel properly which results in poor combustion efficiency.

The fact that the combustion always starts in the same corner of the bowl and propagates in roughly the same manner can be seen in Figure 15 in Appendix. Here the images are averaged over 20 engine cycles. It is noticeable that the distinct gradients found in the single cycle in Figure 8 are smeared out, but the locations for peak intensity are about the same for both the single cycle and the averaged images. The averaged images for the disc case can be found in Figure 14 in Appendix. The combustion seem to start in the left corner for most cycles but as the combustion rate increases the images are smeared out suggesting larger cycle to cycle variations in the location and timing of different ignition kernels.

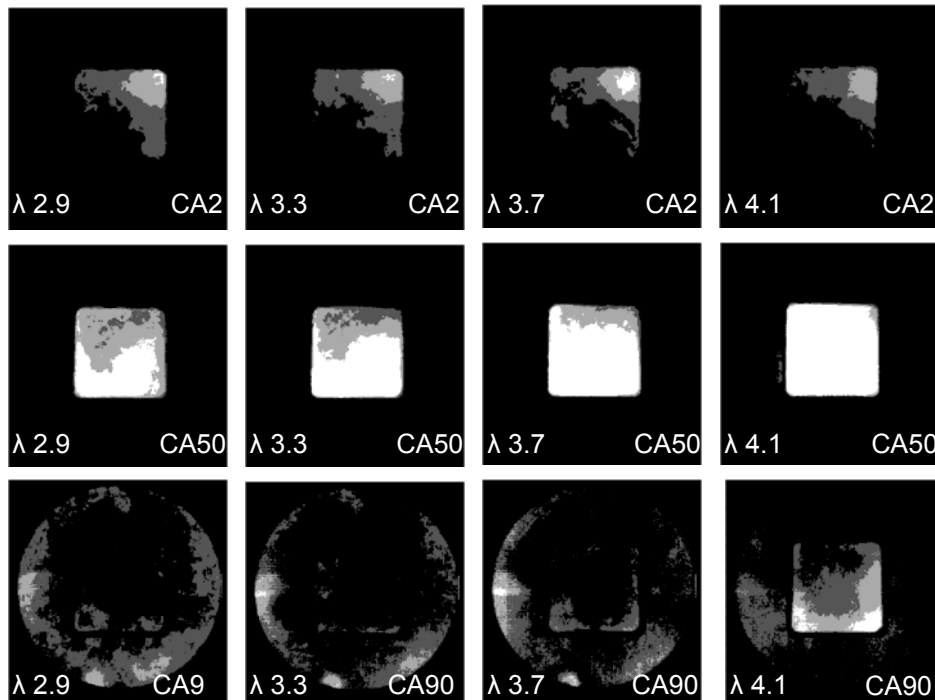

Figure 11. Averaged grayscale images showing four scales of occurrence based on 20 engine cycles. Black: 0-5%, Dark Gray: 5-40%, Light Gray: 40-80% and White; 80-100%.

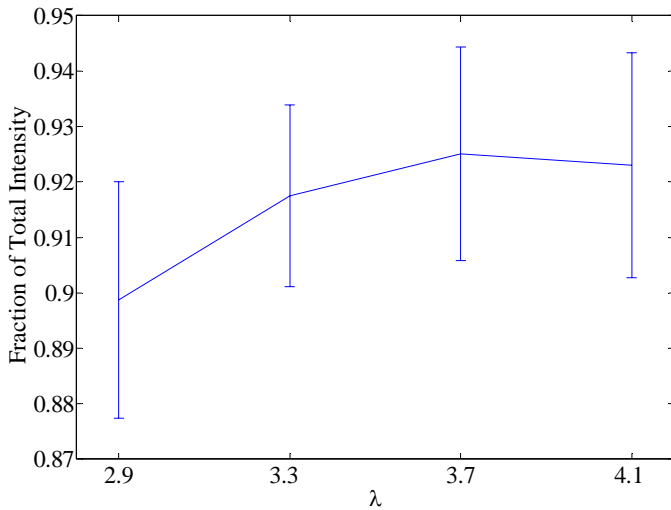

Figure 12. Figure showing fraction of the total intensity which appear in the bowl for four λ -values.

CHARGE STRATIFICATION

The chemiluminescence images in Figure 7 and 8 suggest that the combustion is more stratified in the bowl case. This stratification is either in temperature or air/fuel ratio. Since the camera used was not especially sensitive to background noise, it was possible to estimate this suspected difference in stratification by plotting the mean intensity in the images versus crank angle degree for both geometries. The result can be seen in Figure 13. To compensate for any difference in signal level due to different gain setting of the image intensifier all images have been scaled so that the maximum intensity in the image is set to the same level for both geometries and all running conditions. Since the maximum value in each image is the same, a high mean value means that the image is more homogeneous and a low mean signal means that the image is inhomogeneous. It is found that the mean values for the bowl case is much lower than for the disc case which implies that the combustion is more inhomogeneous in the bowl case. As mentioned earlier this is probably due to temperature stratification. However for both the disc and bowl geometries the mean intensity is lower for richer mixtures, suggesting a more inhomogeneous charge with increased amounts of fuel. This might not be so strange if the evaporation is poorer with increased fueling resulting in locations with richer and leaner mixture than the charge average.

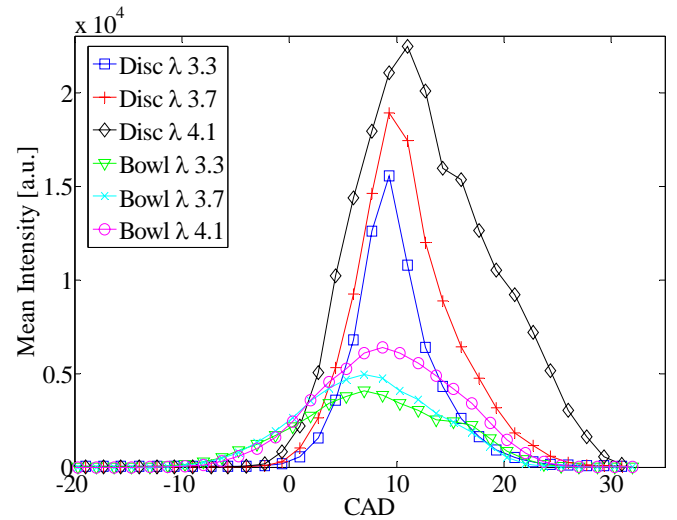

Figure 13. Mean Intensities for three λ -values and for both geometries.

SUMMARY AND DISCUSSION

High speed chemiluminescence imaging was performed in an HCCI engine with two different combustion chambers, one disc shaped and one square bowl in piston. From previous studies it is known that the square bowl in piston generates higher levels of turbulence due to strong squish motion of the charge into the bowl. It has also been found that the ROHR is decreased by the use of a bowl geometry compared to a disc geometry. The purpose of this study was to gain knowledge in the combustion process in the bowl geometry by using the optical technique of chemiluminescence imaging

The results showed that the combustion in the bowl case was more stratified probably in temperature with less ignition kernels compared to the disc case. One possible explanation for this could be that the hot residuals are trapped in the bottom of the bowl introducing temperature gradients throughout the charge. Hot zones are more prone to ignite resulting in combustion that starts in the bowl and propagates throughout the colder charge. It was also seen that the combustion in the squish was much later compared to the bowl which might not be so strange if the temperature is lower in this region, since the heat losses are higher due to the narrow squish distance. Overall this 2-stage combustion is expected to have a lower ROHR and longer duration compared to a mixture like in the disc case with fewer gradients and where more of charge ignites simultaneously. In contradiction to this one might argue that the increased turbulence would improve mixing of hot and cold zones resulting in faster combustion. Since the combustion starts early in the bowl perhaps even before the squish motion has reached the ignition location, the ROHR would not be so high until closer to TDC when the squish motion has started to mix the different zones. A behavior supporting this theory might

be seen in Figure 10 where the intensity rise rate is slow the last 10 CAD BTDC and then increases rapidly after TDC. But from the present studies it is not possible to draw any certain conclusions on the different contributions from turbulence effects and possible temperature stratification effects.

CONCLUSIONS

1. Combustion chamber geometry affects HCCI combustion
2. ROHR was decreased significantly and combustion duration increased with the square bowl in piston geometry compared to the disc geometry.
3. The load can be increased using a square bowl in piston geometry since the pressure rise rate will be lower compared to a disc geometry.
4. Chemiluminescence imaging showed that the combustion starts in the bowl and propagates into the squish volume.
5. Chemiluminescence imaging also showed that the combustion started in the same corner of the bowl in all cycles.
6. Further chemiluminescence imaging showed that the combustion was more stratified in the bowl case probably due to temperature inhomogeneities.

ACKNOWLEDGMENTS

This work has been performed within the Centre of Competence for Combustion Processes at Lund University, Faculty of Engineering in Sweden. The authors would like to thank the financial sponsors and the lab staff.

REFERENCES

1. Aoyama, T., Hattori, Y., Mizuta, J. and Yasuo, S., "An Experimental Study on Premixed-Charge Compression Ignition Gasoline Engine", SAE 960081
2. Christensen, M., Hultqvist, A., and Johansson, B., "Demonstrating the Multi-Fuel Capability of a Homogeneous Charge Compression Ignition Engine with Variable Compression Ratio", SAE 1999-01-3679
3. Christensen, M., Johansson, B. and Hultqvist, A., "The Effect of Combustion Chamber Geometry on HCCI Operation", SAE 2002-01-0425.
4. Christensen, M. and Johansson, B., "The Effect of In-Cylinder flow and Turbulence on HCCI Operation", SAE 2002-01-2864.

5. Kong, S.-C., Reitz, R.D., Christensen, M. and Johansson, B., "Modeling the Effects of Geometry Generated Turbulence on HCCI Engine Combustion", SAE 2003-01-1088
6. Seyfried, H., Olofsson, J., Sjöholm, J., Richter, M., Aldén M., Vressner, A., Hultqvist, B. and Johansson, B., "High-Speed PLIF Imaging for Investigation of Turbulence on Heat Release Rates in HCCI Combustion", Paper to be presented at the SAE world congress in Detroit 2007.
7. Yu, R. X., Bai, X. S., Vressner, A., Hultqvist, A., Johansson, B., Olofsson, J., Seyfried, H., Sjöholm, J., Richter, M. and Aldén, M., "Effect of Turbulence on HCCI Combustion", Paper to be presented at the SAE world congress in Detroit 2007.
8. Sankaran, R., Im, H. G., Hawkes, E. R., Chen, J. H., "The Effect of Non-Uniform Temperature Distribution on the Ignition of a Lean Homogeneous Hydrogen-Air Mixture ", 30th Symposium (International) of Combustion, 2004.
9. Sjöberg, M., Dec, J. E., Cernansky, N. P., "Potential of Thermal Stratification and Combustion Retard for Reducing Pressure-Rise Rates in HCCI Engines, Based on Multi-Zone Modeling and Experiments", SAE 2005-01-0113
10. Christensen, M., Johansson, B. and Hultqvist, A., "The Effect of Piston Topland Geometry on Emissions of Unburned Hydrocarbons from a Homogeneous Charge Compression Ignition (HCCI Engine)", SAE 2001-01-1893
11. Hultqvist, A., Christensen, M., Johansson, B., Franke, A., Richter, M. and Aldén M., "A Study of Homogeneous Charge Compression Ignition Combustion Process by Chemiluminescence Imaging", SAE 1999-01-3680
12. Dec, J. E., Hwang, W., Sjöberg, M., "An Investigation of Thermal Stratification in HCCI Engines Using Chemiluminescence Imaging", SAE 2006-01-1518
13. Habib N. Najm, Phillip H. Paul, Charles J. Mueller, and Peter S. Wyckoff, "On the Adequacy Certain Experimental Observables as Measurements of Flame Burning Rate", Combustion and Flame, 113:312-332, 1998
14. Persson, H., Hildingsson, L., Hultqvist, A., Johansson, B., "Investigation of Boundary Layer Behavior in HCCI Combustion using Chemiluminescence Imaging", SAE 2005-01-3729

CONTACT

Andreas Vressner, MSc M. E.

E-mail: Andreas.Vressner@vok.lth.se

ABBREVIATIONS

ABDC: After Bottom Dead Centre

ATDC: After Top Dead Centre

BBDC: Before Bottom Dead Centre

BTDC: Before Top Dead Centre

CA2: Crank Angle of 2% burned mass fraction

CA10: Crank Angle of 10% burned mass fraction

CA50: Crank Angle of 50% burned mass fraction

CA90: Crank Angle of 90% burned mass fraction

CR: Compression Ratio

HCCI: Homogeneous Charge Compression Ignition

LDV: Laser Doppler Velocimetry

LES: Large Eddy Simulations

PLIF: Planar Laser Induced Fluorescence

LIF: Laser Induced Fluorescence

TDC: Top Dead Centre **PFI:** Port Fuel Injection

APPENDIX

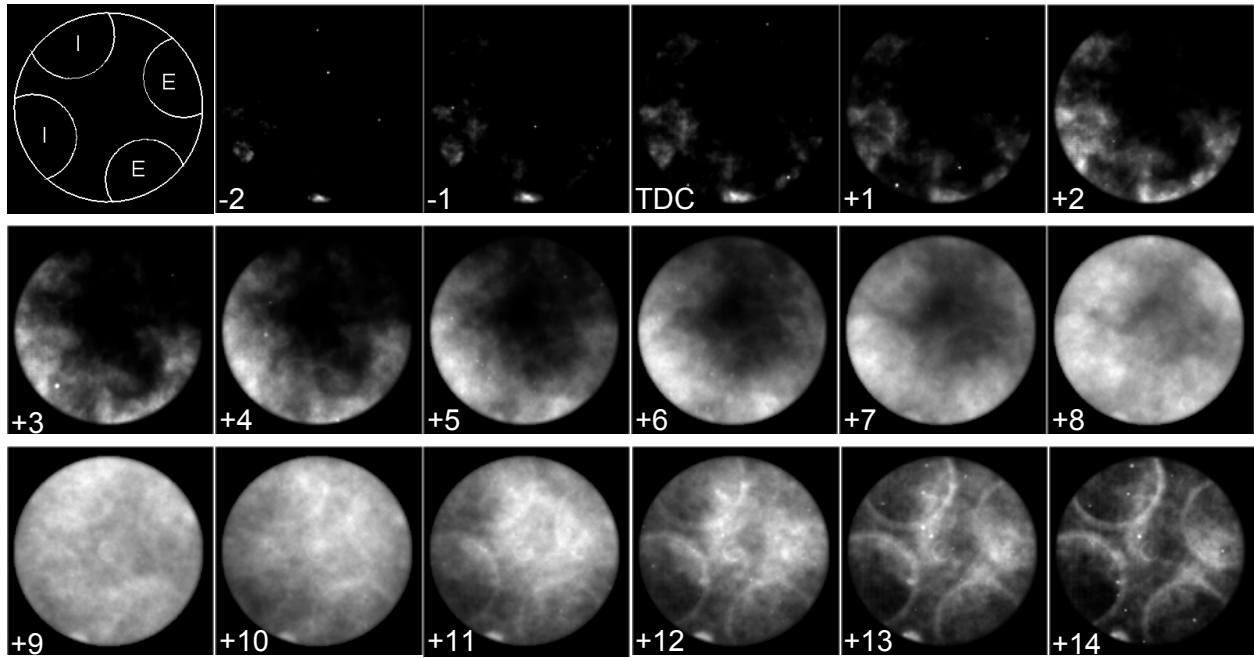

Figure 14. Averaged chemiluminescence images for the disc case. $\lambda = 3.3$ and CA50 = 8 CAD ATDC.

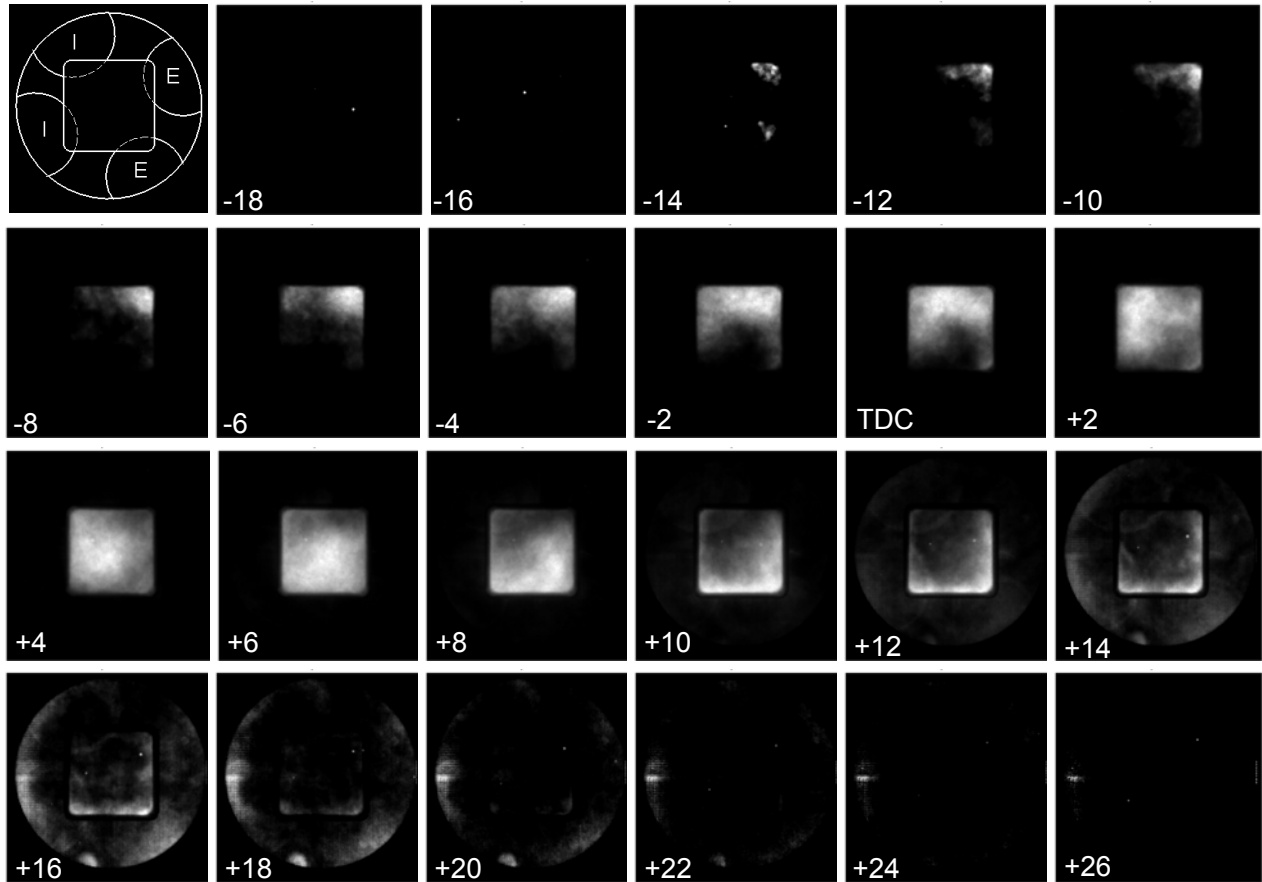

Figure 15. Averaged chemiluminescence images for the bowl case. $\lambda = 3.3$ and CA50 = 8 CAD ATDC.