



LUND UNIVERSITY

Vertical temperature increase in multi-storey buildings

Dahlblom, Mats; Jensen, Lars

Published in:

NSB 2014 : 10th Nordic Symposium on Building Physics, 15-19 June 2014 Lund, Sweden

2014

[Link to publication](#)

Citation for published version (APA):

Dahlblom, M., & Jensen, L. (2014). Vertical temperature increase in multi-storey buildings. In *NSB 2014 : 10th Nordic Symposium on Building Physics, 15-19 June 2014 Lund, Sweden* (pp. 814-821)

Total number of authors:

2

General rights

Unless other specific re-use rights are stated the following general rights apply:

Copyright and moral rights for the publications made accessible in the public portal are retained by the authors and/or other copyright owners and it is a condition of accessing publications that users recognise and abide by the legal requirements associated with these rights.

- Users may download and print one copy of any publication from the public portal for the purpose of private study or research.
- You may not further distribute the material or use it for any profit-making activity or commercial gain
- You may freely distribute the URL identifying the publication in the public portal

Read more about Creative commons licenses: <https://creativecommons.org/licenses/>

Take down policy

If you believe that this document breaches copyright please contact us providing details, and we will remove access to the work immediately and investigate your claim.

LUND UNIVERSITY

PO Box 117
221 00 Lund
+46 46-222 00 00

Vertical temperature increase in multi-storey buildings

Mats Dahlblom, Lic.Tech.¹
Lars Jensen, Professor¹

¹ Lund University, Faculty of Engineering, Division of Building Services, Sweden

KEYWORDS: *Thermal indoor climate, indoor temperature, vertical temperature increase, case study, mathematical model, disturbance model*

SUMMARY:

Indoor temperature is by measurements stated to rise 0.1 – 0.2°C per storey upwards in multi-storey buildings, despite occupants' possibility to control the temperature. Due to upward air temperature gradient in rooms there will be a heat transfer through slabs upwards. The size of this depends on insulation degree of building envelope and slabs and air flow through the building.

With a linear mathematical model, considering 1 m² floor area, it is shown how some parameters affect the heat transfer. Starting position for the model is a building in the thermal balance from which deviations are calculated. The model gives, for a basic case, results that agree well with the measured values.

The vertical temperature increase, results in lower temperature in lower storeys and higher temperature in upper storeys. Total temperature rise for 4 – 28 storeys are in the range 0.5 – 0.7°C, which give vertical heat transfer of 0.6 – 1.1 W/m². A better insulated building envelope will increase the vertical temperature deviations. Better insulated slabs between the storeys will decrease the deviations. A building with well insulated envelope should also have well insulated slabs between storeys to limit the vertical heat transfer and temperature differences between storeys.

1. Introduction

For different reasons inhabitants desire different indoor temperature. In a building with individual measuring and billing (IMB) of space heating costs, it is desirable for each tenant to be able to control the temperature in their apartments, e.g. to keep a low indoor temperature to lower the heating cost.

However, this can be difficult to reach, as an apartment, through the slabs, is vertically thermally coupled with the apartment above and the apartment below and horizontally connected with adjacent apartments through the walls (Jensen 1999) and (Danilevskii 2011). The latter connection is normally weaker due to a smaller connection area. An apartment is also coupled to the surroundings via the external walls, bottom and top slabs and via the total air flow through the apartment.

The inner coupling, i.e. between adjacent storeys, depends on the slab construction. With in situ casted concrete slabs, without insulation, we will a U-value of about 2.7 W/m²K.

The thermal coupling for storeys in the middle of the building to surroundings depends on the U-values for facade walls and windows and the ventilation flow. For buildings erected in southern Sweden during 1960's typical facade U-value, U_f , are 0.6 – 1.3 W/m²K and for windows, U_w , 3.0 W/m²K (BABS 1960). Typical facade/floor area ratio is 0.4 – 0.5 m²/m² and window/floor area ratio 0.1 – 0.15 m²/m². With these measures the building, calculated per m² floor area, will have a thermal coupling through the facade in the range of 0.6 – 0.9 W/K.

The minimum fresh air flow is 0.35 l/s per m² floor area, which give a thermal coupling of 0.42 W/K per m² floor area.

Temperature measurements in one nine storey apartment building situated in Lund, in southern Sweden, has been done in a system for individual measuring and billing of space heating costs. Measurements from a period of 21 months have been analyzed and temperature differences between vertically adjacent apartments are noticed. Despite the occupants possibility to control their temperature a vertical increase in temperature was registered.

2. Aims and objectives

The overall aim of this study is to, with a theoretical model, show why and how vertically adjacent apartments thermally influence each other.

3. Methods and approach

Based on a case study of an apartment block, the temperature measurements are analyzed, mainly with help of Matlab. A mathematical model to simulate the heat transport upwards in the building is programmed and analyzed in Matlab.

3.1 Case study

3.1.1 Description of the building and its building services

The building with nine storeys and a basement was erected in Lund, in southern Sweden, 1965. It comprises 75 apartments, with 198 rooms, on totally 5150 m² heated area. See Figure 1.

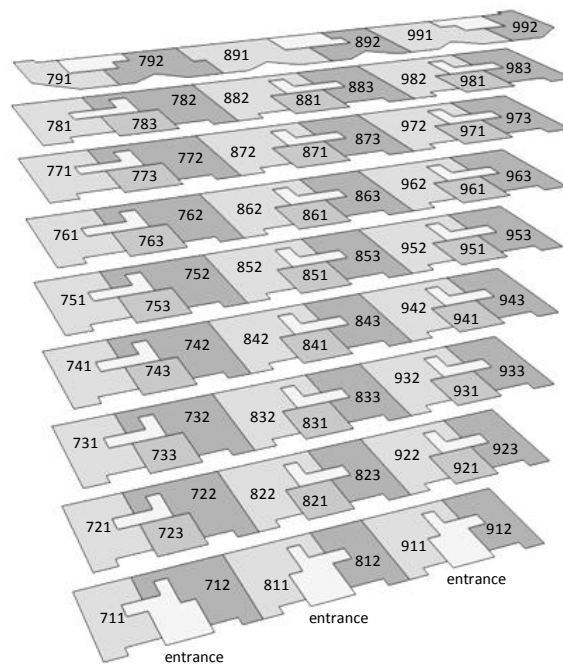

FIG 1. Location of the 75 apartments. Apartments directly above each other, e.g. 711, 721, ..., 791 are addressed as a column; numbered 1 – 9 from left to right. The entrances face close to south.

The construction is typical for the period, reinforced concrete frame with lightweight curtain walls and triple glazed windows, the slabs between storeys are of concrete with a plastic mat. The U-values are assumed to comply with Swedish building codes for the building year, see Table 1. The building is one of ten objects in a study with totally 1177 residential apartments (Dahlblom & Jensen 2011). The building is equipped with a two-pipe hydronic heating systems with radiators connected via a heat exchanger to the district heating system. The building is ventilated by a mechanical exhaust

ventilation system with constant air volume at a rate of 0.615 ac/h, which in this case means 0.41 l/(s·m²) floor area. The used principle for individual metering and billing (IMB) of space heating costs are based on achieved indoor temperature. The rent includes a “comfort temperature” of 21°C, for temperatures down to 18°C, tenants will be refunded and, vice versa, for temperatures up to 24°C tenants will be extra charged (Lunds Kommuns Fastighets AB 2011).

TABLE 1. Assumed properties for the basic case.

Building element	U-value W/Km ²	Area m ²
Facade walls	0.6	320
Windows and balcony doors	2.5	90
Ceiling above top floor	0.6	690
Slab above ground floor	0.6	690

3.1.2 Data collection and processing

A housing company has a system for individual measuring and billing of space heating costs (IMB) in about 3000 apartments, in size varying from one to six rooms. The method used for IMB is based on measurements of indoor temperature.

For the IMB-system the building is equipped with one temperature sensor in each room. For this purpose the temperature is measured every 15 minutes in all bedrooms and living rooms and it should, during the 21 months this study covers, at maximum been $12 \cdot 10^6$ readings, but due to shorter and longer interruptions there are $7.5 \cdot 10^6$ readings, i.e. a mean coverage of 62%. Though this data loss, it provides a unique opportunity to investigate indoor temperatures, absolute levels as well as temperature differences between apartments, in this study concentrated to differences between apartments above each other.

3.2 Vertical temperature differences between storeys for 21 months

Monthly mean temperature for each apartment was calculated for the covered period January 2010 until September 2011. Differences between seven vertical neighbours in the nine columns (Figure 1) were calculated and are presented in Figure 2.

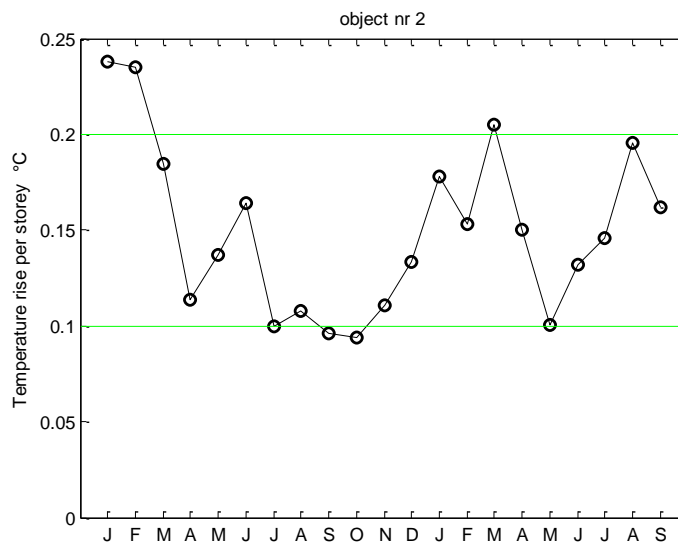

FIG 2. Monthly vertical mean temperature difference per storey for January 2010 to September 2011.

Only seven storeys are included due to floor plan nr 1 and nr 9 differ too much. This means 54 values on temperature differences per month. The temperature rise per storey is between 0.09°C and 0.24°C, in average over all 21 months 0.15°C, average during heating periods is 0.16°C and during non heating periods 0.13°C.

4. Temperature model

The model, illustrated in Figure 3, is normalized to calculate on one square meter floor area. The thermal coupling to the surroundings on each storey is related to one square meter floor area. The coupling depends on U-values for the façade and windows and on the ventilation air flow. The model comprises four temperatures on each storey, the air temperatures at floor level, $T_{air\ floor}$, and ceiling level, $T_{air\ ceiling}$, the floor surface temperature, T_{floor} , and the ceiling surface temperature, $T_{ceiling}$.

A temperature difference, ΔT , between air temperatures at ceiling and floor is set to a fixed value, 2°C. This temperature difference is actually created by up going air plumes from radiators, appliances and occupants and down going plumes at cold façades and window surfaces. Figures can be found in (Rietschel 1960). The model is, storey by storey, set up for the whole building.

The convective heat transfer, P_c , upwards in the room, is partly balanced by the radiant heat transfer, P_r , downwards, from ceiling to floor, described by the parameter h_r . The difference between the convective heat transfer, P_c , and radiant heat transfer, P_r , is equal to the slab heat transfer, P_s , if there are no heat losses, in the model $h_n = 0$. This means also that $T_{ceiling}$ is higher than the floor surface temperature on the next storey, $T_{floor\ above}$. The heat transfer through the slab is described with the parameter h_s .

The outdoor temperature set to zero as the model describes disturbances from steady state conditions. The model is described as a linear equation system, which means all temperatures are proportional to the assumed temperature difference, ΔT .

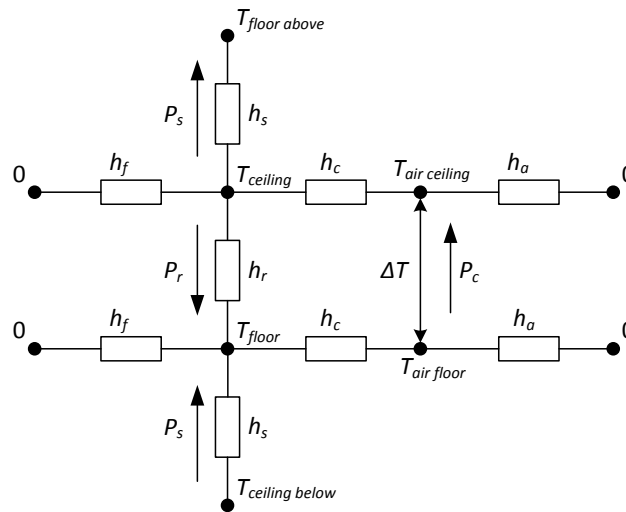

FIG 3. Model for heat transport for one storey

Total thermal coupling, except the vertical, to the surroundings through external walls and windows and air flow through the storey, per square meter floor, area is calculated by equation (1). The air flow is sum of ventilation air flow and infiltration, independent ventilation system type, i.e. it is valid both for exhaust ventilation and balanced ventilation.

$$h_n = U_w \cdot a_w + U_e \cdot a_e + \rho \cdot c_p \cdot q_e \quad (1)$$

Where	h_n	total thermal coupling except the vertical versus floor area (W/(K·m ²))
	U_w	U-value windows (W/(m ² ·K))
	a_w	window area versus floor area (m ² /m ²)
	U_e	U-value external walls (W/(m ² ·K))
	a_e	external wall area versus floor area (m ² /m ²)
	ρ	air density, 1.2 kg/m ³
	c_p	specific heat capacity air, 1000 J/(kg·K)
	q_e	exhaust air flow versus floor area (m ³ /(s·m ²))

This thermal coupling for one storey is in the model divided on four nodes, two connected via heat transport due to differences in surface floor and ceiling temperatures and two due to difference in air temperature, in the model described with h_f and h_a , see Figure 3.

$$h_n = 2 \cdot h_f + 2 \cdot h_a \quad (2)$$

How these couplings are distributed between those 4 nodes are not further investigated and therefore simplified set to be equal, i.e.

$$h_a = h_f = h_n / 4 \quad (3)$$

Losses through the top ceiling slab and the bottom floor slab are included in the model, named h_{se} .

4.1 Parametric study

To see the influence from different parameters a study, where some parameters are varied, has been carried out. The parameters for the basic case are, as close as possible, chosen to agree with the building in the case study above. Though, as only seven of the nine storeys have the same floor plan, this building height was chosen for the basic case. Note that the building has mechanical exhaust ventilation without heat recovery.

Following cases are studied, for details on parameters, see Table 2.

1. building with 4 storeys
2. building with 14 storeys
3. building with 28 storeys
4. better insulated slab between storeys (lower h_s)
5. better insulated bottom slab and top slab (lower h_{se})
6. better insulated facades, windows, bottom slab and top slab
7. better insulated facades, windows, bottom slab, top slab and slab between storeys

5. Results

Results from the parametric study are presented in Table 2 and Figure 4 and Figure 5. ΔT_{storey} in Table 2 was calculated as the total temperature difference between bottom and top storey divided by number of storeys. ΔT_{storey} for the basic case is 0.110°C, to be compared to the temperature rise per storey in the case study above, which was in the range 0.1 – 0.2°C. Corresponding heat transport upwards in the building according to the model is in average per storey 0.811 W/m².

For a building with only 4 storeys the temperature rise per storey seems to be linear; when studying buildings with 14 and 28 storeys respectively it is obvious that it is not, the disturbance in the middle storeys is close to zero. The mean temperature difference between bottom and top is approximately 0.7°C for 7, 14 and 28 storeys compared to 0.5°C for 4 storeys.

An insulated slab between the storeys, case 4, will decrease the mean temperature difference from 0.110°C to 0.079°C per storey, i.e. to 72% compared to the basic case, but the vertical heat transport $P_s = h_s \cdot \Delta T_s$, so this will decrease to 28% compared to basic case.

Better insulated bottom and top slabs, case 5, will increase temperature disturbances to 0.137°C per storey, compared to 0.110°C per storey for the basic case.

Case 6 have better insulated building envelope, close to what is required to meet present building codes. We can see a weaker coupling to surroundings and stronger coupling within the building; more heat is transported upwards in the building, the mean per storey, P_{sm} , is 0.583 W/m², compared to originally 0.811 W/m² for the basic case.

The last case, nr 7, is like nr 6 but with insulated slabs between the storeys. As can be expected, the temperature difference and hence the heat transport will decrease. The vertical heat transport is halved compared to the basic case, Table 2 and Figure 5.

TABLE 2. Input parameters for parametric study and results.

Case	Storeys	U_f W/Km ²	U_w W/Km ²	h_n W/Km ²	h_s W/Km ²	h_{se} W/Km ²	ΔT_{build} °C	ΔT_{storey} °C	P_{sm} W/m ²
basic	7	0.6	2.5	4.40	10	0.6	0.660	0.110	0.811
1	4	0.6	2.5	4.40	10	0.6	0.522	0.174	0.563
2	14	0.6	2.5	4.40	10	0.6	0.702	0.054	1.031
3	28	0.6	2.5	4.40	10	0.6	0.702	0.026	1.139
4	7	0.6	2.5	4.40	4	0.6	0.474	0.079	0.594
5	7	0.6	2.5	4.40	10	0.1	0.822	0.137	0.709
6	7	0.1	1.0	2.67	10	0.1	1.038	0.173	0.583
7	7	0.1	1.0	2.67	4	0.1	0.822	0.137	0.458

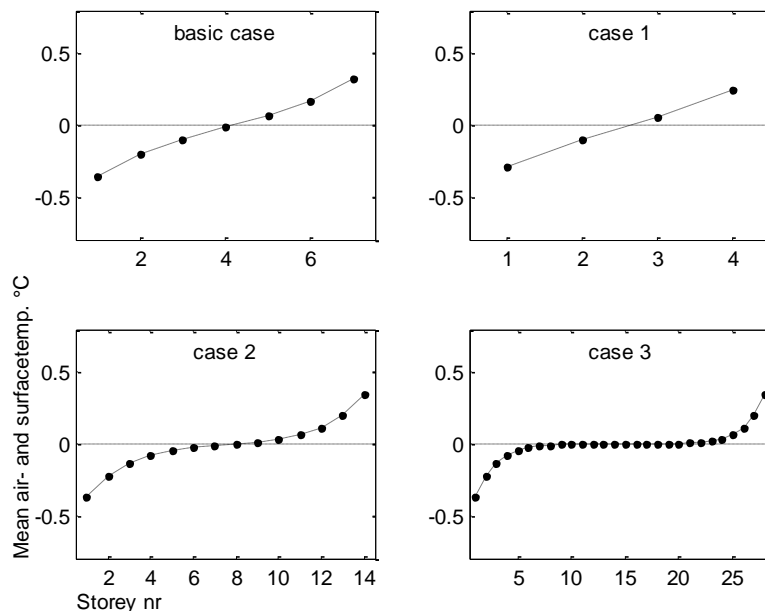

FIG 4. Mean temperature for the 4 nodes in each storey, i.e. deviation relative to a building in thermal balance, basic case and case 1 - 3.

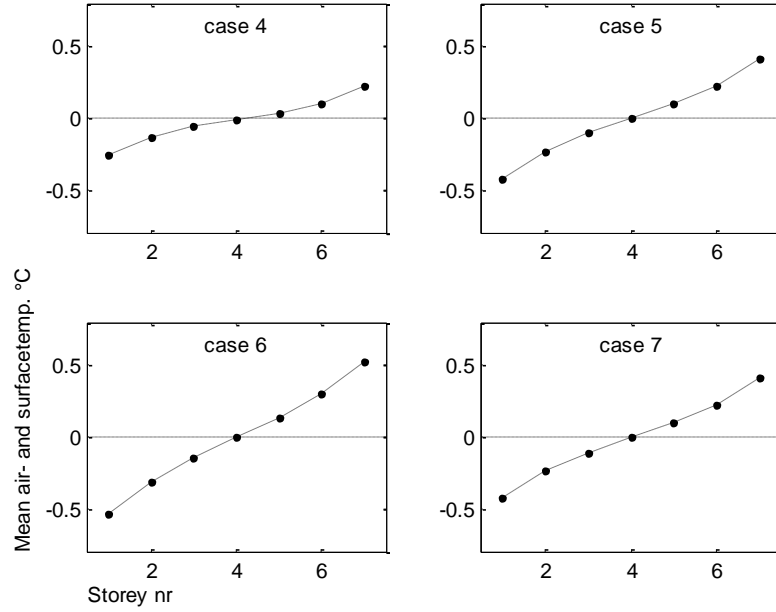

FIG 5. Mean temperature for the 4 nodes in each storey, i.e. deviation relative to a building in thermal balance, case 4 - 7.

5.1 Stationary model

Case 3, floor 10-20, show constant temperature conditions. Constant conditions mean that the temperature difference between floor and ceiling surfaces and across a slab is equal, i.e. there is no temperature increase for any level with constant conditions.

Therefore, if external losses are neglected, i.e. $h_n = 0$, the heat power through a slab can be written as $P_s = h_s \cdot \Delta T_s$, where ΔT_s is the temperature difference across a slab, or as $P_s = P_c - P_r$, i.e. the difference between the convective heat power upward and radiation heat power downward, which can be written as

$$P_c = h_c \cdot (\Delta T - \Delta T_s) / 2 \quad (4)$$

$$P_r = h_r \cdot \Delta T_s \quad (5)$$

ΔT is assumed to be 2°C, while ΔT_s is unknown.

Inserting P_c and P_r make it possible to decide ΔT_s

$$\Delta T_s = \frac{h_c \cdot \Delta T / 2}{h_s + h_r + h_c / 2} = \frac{1}{2 \cdot h_s / h_c + 2 \cdot h_r / h_c + 1} \cdot \Delta T \quad (6)$$

Equation (6) shows that ΔT_s always is less than ΔT , as h_s , h_c and h_r always are positive.

The heat, P_s , upwards in the building can be expressed as

$$P_s = h_s \cdot \Delta T_s = \frac{h_s \cdot h_c \cdot \Delta T}{2 \cdot h_s + 2 \cdot h_r + h_c} \quad (7)$$

With values from the basic case, i.e. $h_s = 10$, $h_c = 2$ and $h_r = 5$, we get $P_s = 1.25 \text{ W/m}^2$, compared to $P_{sm} = 1.139 \text{ W/m}^2$ for case 3.

6. Conclusions

The results in the model are close to the measured temperature differences for the building in the case study, which indicates that the model gives reasonable values.

It can be concluded that there is an internal vertical heat transport upwards in multi-storey buildings.

The temperature difference between floor and ceiling causes a temperature difference over the slabs between storeys which drive the heat upwards. This results in lower temperature in lower storeys and higher temperature in upper storeys and hardly noticeable deviations in between, shown for buildings with a large number of storeys.

Better insulated slabs between storeys will decrease the temperature deviations.

Better insulated top ceiling and bottom floor will increase the temperature deviations.

Better insulated building envelope will increase the temperature deviations.

A building with these three cases of insulation can result in either decreased, increased or no temperature deviations at all versus the basic case.

A building with a well insulated building envelope should also be well insulated between storeys to limit the vertical heat transport upwards the building and the temperature differences between storeys.

7. Acknowledgements

This study was possible to complete thanks to the large data set provided by LKF.

References

- Anvisningar till byggnadsstadgan: [BABS 1960]. (1960). [Instructions for the Swedish building statute]. Stockholm:
- Dahlblom, M. & Jensen, L. (2011). *Reglering av värmesystem i flerbostadshus med individuell värmemätning. Slutrapport för forskning med stöd från CERBOF* [Control of heating systems in apartment buildings with individual heat metering. Final report of research supported by CERBOF]. (Rapport TVIT—11/3006). Lund: Building Services, Lund University.
- Danilevskii, L. N. (2011). Temperature conditions and heat supply of apartments in an apartment house with individual regulators. *Journal of Engineering Physics and Thermophysics*. 84 (2) pp. 359-367.
- Jensen, L. (1999). *Utvärdering av Helsingborgshems system för komfortdebitering* [Evaluation of Helsingborgshems system for individual billing of space heating based on thermal comfort]. Lund: Building Services, Lund University.
- Lunds Kommuns Fastighets AB (2011). Komfortvärme [Comfort heat]. [Electronic] Available: http://www.lkf.se/ImageVault/Images/id_5605/scope_0/ImageVaultHandler.aspx [2012-06-20].
- Rietschel, H. (1960). *H. Rietschels Lehrbuch der Heiz- und Lüftungstechnik. 14. verb. Aufl. 2. Neudruck*. Berlin: Springer.