

**Review of methods used for lowering groundwater levels at
archeological sites, Egypt**



Dahlia S. Hassan

Lund University, Sweden 2006

**Review of methods used for lowering groundwater levels at
archeological sites, Egypt**

Dahlia S. Hassan

Civil Engineer

A thesis
submitted to Lund University in
fulfillment of the requirements for the Degree of
Masters of Water Resources

**Department of Water Resources
Engineering
Faculty of Engineering
Lund University, Sweden**

Report No. TVRL 2006:7

Review of methods used for lowering groundwater levels at archeological sites, Egypt

© Dahlia Hassan, 2006

Institutionen för Tekniska Vattenresurslära
Lunds Tekniska Högskola, Lunds Universitet

Department of Water Resources Engineering
Faculty of Engineering, Lund University
Box 118
SE-221 00 Lund
Sweden

<http://aqua.tvrl.lth.se>

Cover: Island of Agilika, Aswan, Egypt.
(http://members.fortunecity.com/sheilaschechter/egypt_11.htm)

This large temple complex was dedicated to the goddess Isis and its construction was under taken during the third century B.C. Philae is also a superb example of threatened cultural heritage being saved in the face of modern civilization's march to change the environment. The island of Philae and its temples came under threat when the British built the Aswan Dam at the First Cataract. Philae began to spend some of its time beneath the backed-up flood waters of the Nile. The Dam was progressively raised in the following decades, but with the construction of the Aswan High Dam in the 1960s. The temples were certain to disappear forever beneath the river's waters. Fortunately, Philae was saved from drowning. In 1977, a safe dam was constructed around the temples and the water was pumped out. Then the temples were carefully moved to a nearby higher island called Agilkai which was modified to resemble Philae.

Acknowledgement

This work has been carried out at the Department of Water Resources Engineering, Lund University, Sweden and through a field trip during July/ September, 2005 to Cairo, Luxor and Alexandria, Egypt.

I would like to express special thanks to my supervisor Associate Professor Rolf Larsson and Osama Ali Maher at Water Resources Engineering Department, Lund University who supported me financially to carry out all the field work in Egypt and at office during writing this report. Also, thanks to all my friends and classmates.

I would like to thank all the people who guided me in Egypt, especially, professors at faculty of Engineering, Ain Shams University, Cairo and the Supreme Council of Antiquities (SCA), Cairo, Egypt.

Finally, I would like to thank my family for the support on all aspects, especial and deep thanks to my Mother who encouraged and supported me until I finished my degree which I would have never been able to finish without her support.

Dahlia S. Hassan

Lund, 2006

Abstract

Title: Review of methods used for lowering groundwater levels at archeological sites, Egypt

Author: Dahlia S. Hassan

Supervisor: Associate Professor Rolf Larsson, Department of Water Resources Engineering, Lund University, Sweden

Background:

Seven or eight thousands years ago, as the farthest the human memory can reach; the Egyptians established a great civilization that one considered as the origin of civilization on the Earth. There is no place in Egypt where one cannot find evidences that enlighten this civilization and tell about Egypt's role in most of the world's historic events from the beginning of mankind until the present time. In the recent decades, it has been noticed that this 'indestructible' heritage that once stood in dry sand are bathed in water throughout the year and limestone and sandstone are gradually crumbling back into sand and this heritage could disappear in our lifetime. The number of decaying monuments is not exactly known, but it is estimated to be a considerable number from the deadly white salt crystallizations that could be seen on monuments walls throughout the country. The problem is caused by rising groundwater which is eating away at the monuments. The story has begun after the construction of Aswan High Dam (AHD) which has been affecting Egypt's water table over the last 30 years; AHD has minimized the fluctuation of surface and ground water levels. Groundwater, which contains water-soluble salts, is rising annually. When the groundwater is soaked up by the pores within the sandstone and limestone foundations, salts are absorbed by the structures. As groundwater evaporates, these salts accumulate on the monuments surfaces.

Objective:

The main objective of this study is to review the methods used to protect the archaeological sites in Egypt against groundwater threats. In this report, some reports of either finished or on-going projects are reviewed. These projects are implemented by governmental agencies or international consultants to face the adverse effects of groundwater against the monuments.

Method:

A field trip to Egypt was carried out in July/September, 2005 for site investigations and assessment of water related damage. Alexandria governorate in north Egypt and Luxor city in south Egypt were chosen for studying the problem. It is worth mentioning here that one third of the world's heritages are located in Luxor city. Three temples in Luxor; Ramseum, Madiant Habu and Sethi and another site 'Kom elshoafa' in Alexandria were chosen for field investigations. Intensive meetings were done with locals to discuss the problem and collect data about irrigation schemes, crops and drainage systems.

Conclusions:

Rising of groundwater table is a consequence of; 1) construction of the AHD which prevented freshwater floods and provided water for agriculture almost year-around that led to over-irrigation of lands by farmers in absence of any governmental control and 2) leakage from sewage systems (if they exist).

The methods used were found to promote only short-term solutions that do not attack the problem at the source. However, the methods used are effective for the present time; still there are many limitations and unanswered questions about the sustainability of such methods on the long run.

Keywords:

Aswan High Dam (AHD), irrigation, groundwater table, Water-soluble salts, salts accumulations

Table of Contents

Acknowledgement	i
Abstract	ii
List of figures.....	v
Equations.....	vi
Abbreviations	vi
Chapter 1. Introduction.....	-1-
1.1 Background.....	-1-
1.2 Problem Statement.....	-5-
1.3 Study Objective.....	-8-
1.4 Methods.....	-9-
1.5 Thesis Organization.....	-9-
Chapter 2. Groundwater theory and practice.....	-10-
2.1. Water in soil.....	-10-
2.2. Upward movement of soil water from the water table.....	-11-
2.3. Groundwater dynamics.....	-11-
2.4. Groundwater flow.....	-12-
2.5. Groundwater balance system.....	-13-
2.6. Groundwater problems.....	-14-
2.6.1. Salt transport in soil.....	-14-
2.6.2. Heave and settlement.....	-14-
2.7. Irrigation schemes in Egypt.....	-15-
2.8. Groundwater control.....	-16-
Chapter 3. Projects Review	-27-
3.1. Lowering groundwater levels at Esna, Abydos, Luxor and Karnak sites.....	-28-
3.2. Lowering groundwater levels at Hammam eloazeroon site in Adydos.....	-31-
3.3. Lowering groundwater levels at Esna site.....	-34-
3.4. Salvation of Karnak and Luxor temples.....	-38-
3.5. Lowering groundwater levels at Hawarah pyramid and Kiman Fares site.....	-43-
3.6. Lowering groundwater levels at El-Shatbi tombs.....	-46-
Chapter 4. Discussion.....	-49-
Chapter 5. Conclusions and recommendations.....	-52-
References.....	-54-

List of figures

Figure 1: *Map of Egypt* (source: www.cyber-diver.com/egypt_map.htm. last accessed on November 15th, 2006).

Figure 2: *Aswan Low Dam (ALD)* (source: www.cyber-diver.com/egypt_map.htm. last accessed on November 15th, 2006).

Figure 3: *Aswan High Dam (AHD)* (source: www.cyber-diver.com/egypt_map.htm. last accessed on November 15th, 2006).

Figure 4: *The Nile's water levels recorded in some wells at Karnak temple, Luxor* (GWRI 97, Report).

Figure 5: *Different ways of water-soluble salts to reach the monuments*. SWECO, 1982

Figure 6: *Adverse impacts of water-soluble salts on monuments' foundations and separation of paint and layers of rocks* (field trip, Seti Temple, Luxor, August, 2005).

Figure 7: *Traditional classification of subsurface water*. (After R.C. Ward et al. 1990)

Figure 8: *Diagrammatic relationship between unconfined aquifer (A), perched aquifer (B), and confined aquifer (C)*. (After R.C. Ward et al. 1990)

Figure 9: *Dewatering systems applicable to different soils* (Courtesy of the Moretrench Crop., Rockaway, N.J.)

Figure 10: *Dewatering open excavation by ditch and sump* (After U.S. army (Modified from "Foundation Engineering, "G. A. Leonards, ed., 1962, McGraw-Hill Book Company, used with permission of McGraw-Hill Book Company.)

Figure 11: *Wellpoint system-Layout for Trench Excavation* (Groundwater and Dewatering handouts, El-Didy M.A. 2004)

Figure 12: *Wellpoint system-General Layout* (Groundwater and Dewatering handouts, El-Didy M.A. 2004)

Figure 13: *Uses of Deep wells* (Groundwater and Dewatering handouts, El-Didy M.A. 2004)

Figure 14: *Dewatering of a fine-particled soil by Electro-osmotic* (<http://elchem.kaist.ac.kr/vt/chem-ed/sep/electrop/graphics/electroo.gif>)

Figure 15: *Electro-osmotic flow of water* (Jumikis A.R., (1971) Foundation Engineering, Rutgers University, The state University of New Jersey).

Figure 16: *Grout curtain or cutoff trench around an excavation.* (U.S. Army Corps of Engineers)

Figure 17: *Artificial freezing of soil for a water-supply tunnel shaft* (Jumikis A.R., 1971) *Foundation Engineering*, Rutgers University, The state University of New Jersey)

Figure 18: *Tile drainage* (source: www.cyber-diver.com/egypt_map.htm. last accessed on November 15th, 2006).

Figure 19: *Map of Esna, Abydos, Luxor and Karnak temples* (source: www.cyber-diver.com/egypt_map.htm. last accessed on November 15th, 2006).

Figure 20: *Hydro-geologic cross section at Luxor area showing the different lithological hydrologic units* (RIGW, 1997).

Figure 21: *Groundwater levels in Esna temple area* (project report).

Figure 22: *Five boreholes with different depths are drilled at specified points around Esna temple* (project report).

Equations:

Equation 2.1: Darcy's law.

Equation 2.2: groundwater balance

Abbreviations:

SCA : Supreme Council of Antiquities

RIGW: Research Institute of Groundwater

AHD : Aswan High Dam

ALD : Aswan Low Dam

Chapter 1. Introduction

1.1 Background:

Seven or eight thousand years ago, as the farthest the human memory can reach, the Egyptians established a great civilization that was considered as the origin of civilization on the Earth. There is no place in Egypt where one cannot find evidences that enlighten this civilization and tell about Egypt's role in the human history from the beginning of mankind to the present time. The ancient Egyptians (the pharaohs) have left to the world a splendid heritage. The Egyptian pyramids are the most famous of all the ancient monuments, the only remaining wonder of the seven wonders of the ancient world. The Egyptian monuments are considered as national treasure for Egyptians and international treasure for the whole world since it represents the glory of the old Egyptian civilization. However, this heritage is considered an issue of international interest and responsibility; nowadays, countless monuments of this heritage are facing severe deterioration due to changes in groundwater regime. The construction of the Aswan High Dam (AHD) is considered one of the main reasons for rising of groundwater table. Groundwater table has risen over the last thirty years throughout the country which creates permanent contact between this water-soluble salt and the monuments, thereafter; water is soaked up by the stones and rocks and then water evaporates leaving behind salts accumulations on monuments surfaces. Crystallization of salt particles on the surface of the monuments accelerate weathering damage of sandstones, affects the stability and cause paintings to separate and fall down from the rocks which at the end crumble and decay into sand.

Egypt:

The Arab Republic of Egypt, commonly known as Egypt, (*Miṣr* in Egyptian dialect). Egypt is located in the northeast of Africa with an area about 1,000,000 km². Egypt's population is around 77,505,756 (July 2005 est.). Nearly 99 % of the population inhabit the length of the river Nile (about 40,000 km²) which is less than 4 % of the total country area. Therefore, the Nile is considered as the main source of water for Egypt, with an annual allocated flow of 55.5 million km³/yr (Egypt's water share from the Nile

according to the Nile Waters Agreement in 1959) which is approximately about 95 % of Egypt's water supply.



Figure 1: Map of Egypt (source: www.cyber-diver.com/egypt_map.html)

Why Egypt was in great need for a Dam?

The Nile Valley stretches about 1000 km from the Egyptian-Sudanese borders to the north coast on the Mediterranean. The flooding period of the Nile begins in August and ends in October, originating as rainfall on the Ethiopian Plateau, which falls down in summer causing the annual flood of the Nile. At the peak of the flood, the flow of the river increases (sometimes sixteen times its original flow). Rainfall on the Ethiopian Plateau varies from year to another, and so, in some years the amount of flood could cause a massive damage to cultivated lands, cities, roads...etc. Most of the Nile discharge was drained off into the Mediterranean with all the nutrients and minerals which enrich soil and cultivated lands along the Nile course. One crop rotation per year was practiced due to shortage of water and adverse impacts of flood on agriculture. From

the preceding reasons, it is very obvious that Egypt had no other choice but to build a dam for controlling the Nile flow.

First attempt was the construction of Aswan Low Dam (ALD) (figure 2). The project was introduced by a British firm and the construction began in 1899.



Figure 2: Aswan Low Dam (ALD) (source: www.cyber-diver.com/egypt_map.html).

After the inauguration of the ALD in 1902, the height of the ALD (54 m high) was found to be insufficient to stop the flood and has inadequate reservoir area, so the height of the dam was raised two times in 1907–12 and 1929–33. But despite of all these efforts, the dam was overflowed in 1946. At that time, the idea of raising the ALD a third time was not welcomed; therefore, it was decided to build a second dam 6 km down river from the ALD. This was achieved by the inauguration of the current AHD (figure 3) on January 15th, 1971.



Figure 3: Aswan High Dam (AHD) (source: www.cyber-diver.com/egypt_map.html).

However, the AHD has many benefits, e.g. availability of irrigation water that makes year-round irrigation possible and hence, increase cultivated new lands in millions of hectares and cropping yield, taming freshwater flash floods and generating of hydroelectric power, the erection of the AHD raised many significant environmental and socio-economic issues that should be seriously discussed and taken into consideration from decision-makers. Hereafter, some of issues affecting the groundwater regime along the river Nile:

- Waterlogging and salinization have resulted from traditional irrigation practices by famers.
- The annual natural water level variations of the Nile before completion of the AHD were approximately 7-9m (raunecker, 1978), so before the AHD construction, groundwater had been rising during the flood and gradually decreasing afterwards, but after the AHD construction, these variations in water

table were very much minimized owing to the prevention of freshwater floods after the construction of the AHD.

1.2 Problem Statement:

The fast development in Egypt in industrial, agricultural, constructional and social sectors after the AHD construction accompanied by enormous growth in population have resulted many challenges to decision-makers i.e. how to meet the future food requirements that cope with the high annual increase of population rate. Agriculture expansion was, and still is, one of the main chosen strategies that has been taken into consideration and became on top of the national priorities. Due to availability of water all over the year, cultivated lands have increased by millions of hectares and new desert reclamation projects are widely spreading. However, the goals of constructing the AHD have been somehow achieved; the building of the AHD, after almost thirsty years, has evolved some critical impacts on the water system in Egypt. Over-irrigation of agricultural lands, which usually is traditional basin irrigation, in addition to, absence of an effective drainage system increased the vertical seepage of excess drainage water to groundwater aquifers, and therefore, recharges these aquifers which accordingly, rise groundwater levels to the extent that groundwater in the aquifers has become higher than water level of the Nile. Figure 4, shows the huge change in groundwater levels that were recorded in some wells in 1900, 1969 and 2001 at Karnak temple, Luxor. It is very obvious that water levels were increasing during the flood period August-November and then gradually decreasing after the flood. But, it was recorded from the same wells that in the recent years water levels are more or less the same; in other words, the seasonal variations after the construction of the AHD in the 1960s have been very much reduced.

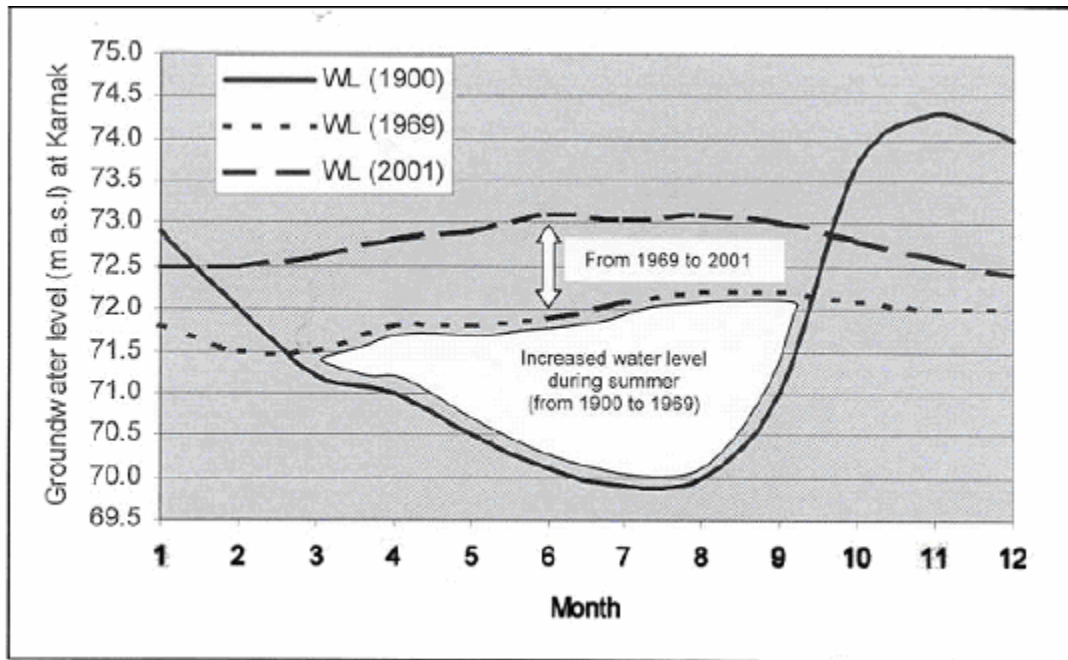

Figure 4: The groundwater levels recorded in some wells at Karnak temple, Luxor (GWRI97).

Furthermore, Salinity and waterlogging in groundwater have increased by a considerable rate which might be resulting from increased human activities, urbanization, irrigation and adding more fertilizer by farmers to increase soil fertility that lost most of its natural fertilizing supply after the AHD construction due to preventing the Nile flashflood which used to bring with it rich silt and wash many of the monuments in its way. These impacts, not only, have adverse effects on soil fertility, but they have seriously contributed to the deterioration of archaeological sites that exist along the Nile course. The problem is caused by rising groundwater levels that contain high concentrations of salts dissolved in it and leaking or non-existing sewage systems. When water gets in contact with monuments stones; limestone and sandstone, water is soaked up by the stones, see figure 5. Capillary forces maintain a continuous transport of water-soluble salts in an upward direction which increases salts concentrations in the upper soil layers near structures' foundations.

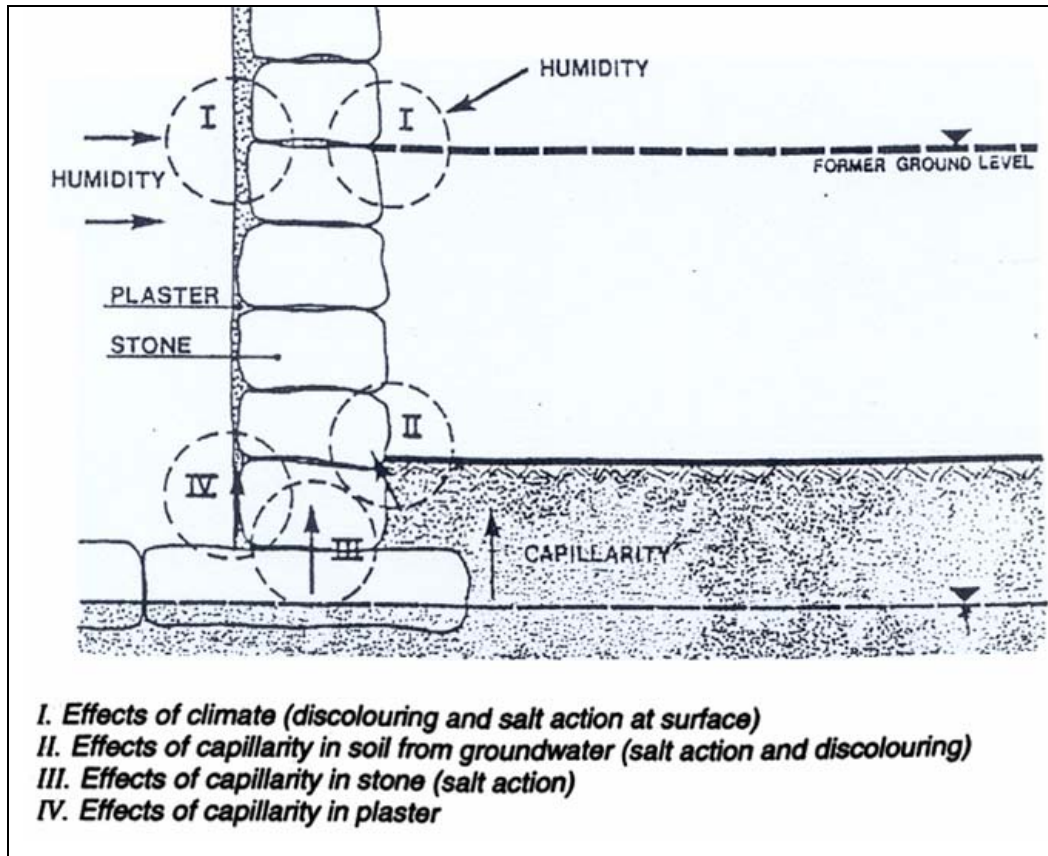

Figure 5: Different ways of water-soluble salts to reach the monuments (SWECO, 1982)

Mineral salts in water dissolve the stones and when water evaporates, salt crystallizations are left behind. The continuous presence of salt particles due to rising of shallow groundwater are eating away the monuments bodies and contributing to the separation of paint and layers of rocks, deterioration and decaying of these archaeological structures (figure 6).



Figure 6: Adverse impacts of water-soluble salts on monuments' foundations and separation of paint and layers of rocks (field trip, Seti Temple, Luxor, August, 2005)

Various international organizations, especially, the United Nations Educational, Scientific and Cultural Organization (UNESCO) are co-operating with the Egyptian government to save this heritage from disappearing and fading out.

1.3 Study Objective:

The main objective of this study is to review the methods used to protect the archaeological sites in Egypt against groundwater threat. This objective was carried out by:

- Collecting information and relevant published/unpublished reports of either finished or on-going projects tackling the threat of groundwater against the historic sites.

- discussing the history and causes of waterlogging and shallow groundwater table rise;
- Suggest practical and sustainable solution to the problem in the future.

1.4 Methods:

A field trip to Egypt was carried out in July/September, 2005 for site investigations and assessment of water related damage. Alexandria governorate in north Egypt and Luxor city in south Egypt were chosen for studying the problem. It is worth mentioning here that one third of the world's heritages are located in Luxor city. Three temples in Luxor; Ramseum, Madiant Habu and Sethi and another site 'Kom elshoafa' in Alexandria were chosen for field investigations. Intensive meetings were done with locals to discuss the problem and collect data about irrigation schemes, crops and drainage systems. Various Egyptian authorities which are directly or indirectly involved in this problem were contacted and some meetings were held, especially, with the Supreme Council of Antiquities (SCA), which is the main governmental authority in charge of the archaeological sites in all aspects; administration, guarding,...etc. Contact persons in ministry of Water Resources and Irrigation (MWRI) and scholars in faculty of Engineering, Ain Shams University, Cairo were contacted to collect relevant data and reports.

Data collected include information from about six final reports of either finished or on-going projects that deal with solving groundwater threat to the monuments. This report highlights the engineering groundwater control methods implemented in some projects.

1.5 Thesis Organization:

This chapter presents the problem statement, a general view on the study objectives, the method of work, and thesis organization. In chapter two, review of some general considerations on groundwater problems in soil, physical processes and irrigation schemes and its contribution to the rise of groundwater table is introduced with general illustration of various dewatering methods used around the world. Chapter three presents a literature review on some reports collected during the field trip of different finished or on-going projects that tackle water related damage problem. In chapter four, discussion is pointed up. And finally, chapter five, the main concluded points are also pointed out, and recommendations are included.

Chapter 2. Groundwater theory and practice

Groundwater is considered as a “natural reservoir” for fresh water under the ground surface and a renewable source of water that has a remarkable distinction of being a highly dependable and safe source for fresh water supply.

Shallow groundwater is groundwater that is close enough to the ground surface where water table is within 20 feet of the ground surface at any time during the year, it is also called ‘young groundwater’.

In this chapter, some general considerations on groundwater problems in soil, physical processes and irrigation schemes and its contribution to the rise of groundwater levels are introduced with general overview of various dewatering methods used around the world.

2.1. Water in soil

Figure 7 shows four main zones of subsurface water in a river valley. Precipitation, the main input of water, infiltrates into the ground and keeps moving downward where it percolates the unsaturated/aeration zone (Vadose Zone) where most of the voids in the soil are filled with air and/or water vapor. With increase in depth, the soil pore spaces are filled totally with water. This zone is called the saturation zone. The saturated capillary or capillary fringe zone appears immediately above the zone of saturation (groundwater table; where the pressure is atmospheric). Capillary forces result from *surface tension* hold water around soil particles due to the strong attraction force between soil particles and water molecules themselves in this zone.

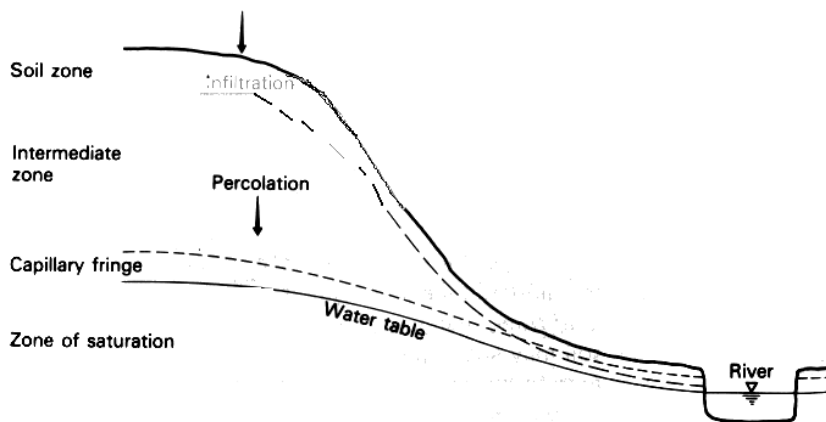

Figure 7: Traditional classification of subsurface water. (After R.C. Ward et al. 1990)

2.2. Upward movement of soil water from the water table

Capillary rise is defined as the height above a free water surface to which water will rise by capillary force or it is the upward transport of water in the unsaturated zone. Gravity force, matric suction (capillary and adsorption forces) and the unsaturated hydraulic conductivity control the capillary rise. The evapotranspiration process stimulates the upward movement of soil waters. The range of the capillary zone is dependent most of the time on water table depth, the soil composition and distribution of soil particles. Capillary zone thickness corresponds to the air entry value; tension needed for air to enters all the soil pores (Childs, 1969). The highest rates of capillary rise occur in soils where the texture becomes progressively finer with height above the water table (Wind, 1961). Rise in temperature accelerates evaporation and transpiration which, in turn, increase the rate of water upwards transport. Hence, in arid and semi-arid areas where the rates of evaporation are high, such movement may lead to formation of damaging accumulation of salt at the ground surface, even where the water table occurs at a considerable depth (Wind, 1961). These salt accumulations crystallize at rocks surface, dissolve the sandstone and eat away foundations which speed up the degradation of structures.

2.3. Groundwater dynamics

Groundwater is the water that occurs in the saturated zone in soils and rocks. A geological formation comprising layers of rock or unconsolidated deposits that contain sufficient saturated material to yield significant quantities of water is known as an aquifer (Lohman, 1972). Figure 8 shows a diagrammatic classification of aquifers. According to the kind of layers and distinct different hydraulic properties aquifers are classified to one of the following types:

1. Confined aquifers (artesian), bounded by a less permeable layer and rest on a saturated pervious layer which is usually a clay or silt sediment or cemented rocks.
2. Unconfined aquifers (phreatic; this is free water table aquifer), the upper boundary is formed by a free water table (phreatic) and the lower one is formed by a pervious layer. Special case of unconfined aquifer is *Perched groundwater*

where the impermeable boundary layer is not continuous over a very large area and is situated at some height above the main groundwater body (Ward et al. 1990).

3. Semi-confined aquifer or leaky aquifers bounded by saturated pervious layer while the upper and/or lower boundaries are either impervious or semi-pervious.

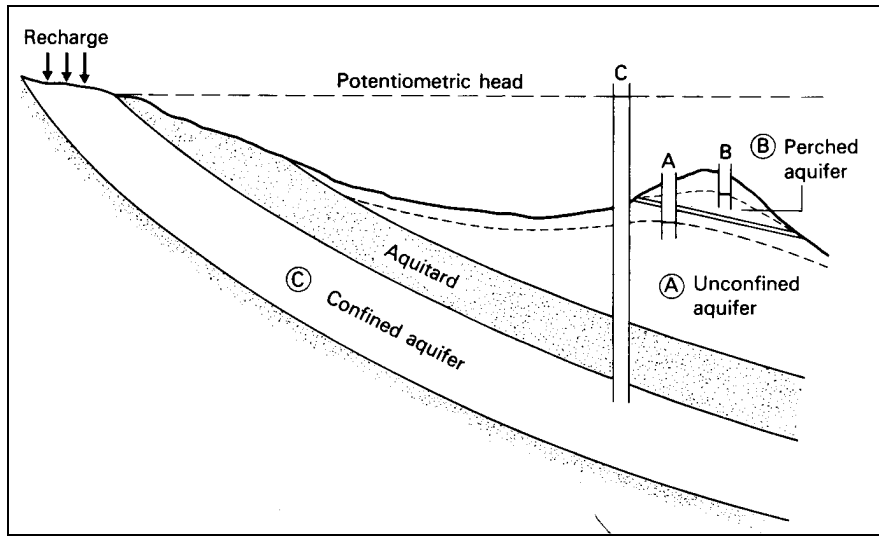

Figure 8: Diagrammatic relationship between unconfined aquifer (A), perched aquifer (B), and confined aquifer (C). (After R.C. Ward et al. 1990)

Water in confined aquifers is under pressure while in unconfined aquifers water table is free. Water pressure in an aquifer is measured by piezometer in confined aquifers. For unconfined aquifers the hydraulic head may be taken equal to the height of the water table.

2.4. Groundwater flow

Water flows from region of high hydraulic head area to region of lower hydraulic head. The theory of groundwater movement is explained by Darcy's law. The direction and rate of groundwater movement in a porous medium may be calculated from the prevailing hydraulic gradient and the hydraulic conductivity of the water-bearing material by the use of the Darcy equation (Robinson et al. 1990). Darcy's law explains that the groundwater

discharge Q is proportional to the difference in the hydraulic head ΔH and cross sectional area A and inversely proportional to the length ΔS , it may be written as

$$Q = Av = -AK \frac{\Delta H}{\Delta S} \quad (2.1)$$

Where, K is the saturated hydraulic conductivity expressed in m/d; v is the velocity of groundwater expressed in $m^3 / m^2 \cdot d^1$; the negative sign is to indicate that the hydraulic head decreases in the flow direction.

2.5. Groundwater balance system

Porosity affects the amount of groundwater stored in the ground. It depends on the shape, arrangement and degree of sorting of the constitute particles, compaction and the extent to which modification arising from solution, cementation, compaction and faulting have occurred (Robinson et al. 1990).

Maintaining balance in groundwater system is very hard to achieve due to the complexity and difficulty to control the inputs (recharge) and outputs (extraction) of the system.

$$\text{Groundwater storage} = \text{Groundwater recharge} - \text{extraction} \quad (2.2)$$

If the two elements are equal then the system is in equilibrium and water stored in the ground will remain constant; if the recharge exceeds the extraction, water stored in the ground will increase while, if the extraction exceeds, water stored in the ground will decrease.

Recharge to groundwater system may be done by one or more of the following elements:

1. precipitation;
2. seepage from surface water bodies;
3. leakage from adjacent aquitards and aquifers; and
4. Irrigation.

While, extraction (discharge) may be done by one or more of the following elements:

1. evaporation;
2. discharge to surface water bodies;
3. leakage through aquitards into adjacent aquifers; and

4. Artificial abstraction.

2.6. Groundwater problems

2.6.1. Salt transport in soil

Salt accumulation is a problem in arid/semi-arid regions where the rates of evaporation are high. Additionally, capillary rise transports water from the water table towards the soil. This water is mixed with dissolved mineral salts and when soaked up by rocks and stones of structures and/or the root zone of the soil. With rise of temperature, water evaporates and leaves behind salts accumulations on the ground surface and rocks surface. Repeating this process several times may lead to formation of crystallized salt layers on the structures surface and increase with high rates the soil salinity and then, salts transport through walls in upward direction will consequently increase. The most widely used method to solve this problem is e.g. scraping the soil and leaching to wash out all salts near the foundations of the structures.

2.6.2. Heave and settlement

Problems related to sudden lowering of groundwater levels in soils are e.g. settlement and heave. Settlement is considered as gradual compression for the soil. It depends on many factors e.g. density, void ratio, grain size and shape and past loading history of the soil deposit. If the load applied to the soil exceeds the designed load, settlement will take place during or after the construction. When soil is underwater (or has significant pore water pressure) there is a stress acts on soil particles due to the load of water. Thus, water serves as a stress that compact soil particles together, lowering this water table level by pumping water from the ground, if it is done too strongly, fine particles from the underlying soil are brought up. The ground shifts to compensate for the missing particles that are sucked up with the water, destabilizing the walls and foundations of structures which might cause settlement or cracks to those foundations and columns that support the building.

Heave cause deformation and cracking mainly on clay soils. Clay soils swell on wetting and crack on drying. This clay swelling kind of soils contains minerals that attract and absorb water when soils are subjected to moisture on a long time. Water molecules are

pulled together as more water is absorbed leading to increase in soil pressure or expansion of the soil volume.

2.7. Irrigation schemes in Egypt

Egypt possesses a large-scale irrigation system. Agriculture lands consist of two kinds; old land which is situated on the two banks of the Nile and considered as the most fertile agriculture land. The other kind is the new cultivated land which was reclaimed after construction the AHD due to the availability of water year-round in order to face the fast growing population rate of the nation. Most of the cultivated lands are owned by farmers who pump water directly from the Nile to irrigate their farms. Thus, the systems are not well-controlled by authorities and farmers take over the steering wheel. Almost all the researches and studies pointed out the great need for improvement on the farmer-scale water control in Egypt. Some of these studies are engaged in implementation of a new approach 'Water Users Association' (WUA) which deals with farmers' involvement in managing the irrigation systems in each country. Furthermore, increase farmers' awareness with new irrigation technologies and fertilizers that will improve their farmer and help facing the water scarcity in such counties. Egypt is facing a situation of water scarcity (Abu Zied, 1992, p.14).

It is true; however, that Egypt was in great need for the construction of the AHD, the consequences of the AHD construction are not all for the best. The AHD eliminates the Nile flood and increases water storage to be used throughout the year for irrigation, but at the same time, the availability of water increased the cropping seasons into three crop rotations (it was only one in the ancient time). In addition to that the misuse of irrigation water by unaware farmers and old drainage techniques has risen the mean groundwater levels and therefore, the historic monuments and foundations of ancient temples and buildings are under great threat. 'Egyptian agriculture is considered to be one of the most consumptive of irrigation water in the world. This high consumptive is not due to reasons related to soil, but mainly related to the wasteful use of irrigation water' (Samaha, 1979:253). Actual measurements point out that farmers generally apply 50 to 250 percent more water than is needed by the crops and for leaching requirements (IIIP,1993b:10). A

rising and permanently high water table in the irrigated areas of the Nile Valley is accelerating the damage of the ancient monuments, buildings, and tombs.

2.8. Groundwater control

Uncontrolled Groundwater may cause various problems, as mentioned in the preceding section, e.g. heave, settlement, and instability of excavation slopes or foundation soils that may lead to total collapse of structures. The need for controlling groundwater levels is increasing day after day due to the vast development in the world and the haphazard interference of man in the natural groundwater system e.g. irrigation schemes, drainage networks, misuse of water resources,...etc. Rise of groundwater table is affected by topography, high precipitation, over-irrigation accompanied with unsatisfactory drainage network and inadequate sanitation and sewer systems. There is a great need to lower and maintain groundwater table at a certain depth below the foundation and to prevent water table from rising to the surface through capillary action which consequently will minimize groundwater related damage problem and its adverse effect on the structures.

Dewatering seems to be the most common solution for lowering groundwater levels.

Various methods for dewatering have been recently developed. However, lowering groundwater levels prevent the aforementioned groundwater related problems; the dewatering process has its own side effects that threaten structures foundation if it is not well designed and implemented. Excavation characteristics should be taken in consideration e.g. Location and topography, adjacent buildings, size and depth of excavation. Hereafter, description and illustration of dewatering methods and the requirements, techniques and suitability of each method to different kind of soils will be mentioned.

Methods for groundwater control

- **Methods selection depends on some factors:**
 1. Type of excavation
 2. soil water conditions; Hydraulic conductivity of soil
 3. Hydro-geological system (Confined, Unconfined)
 4. Extent of the area to be dewatered

5. Drawdown required
6. Existence of adjacent structures or water bodies (river, canal, lake)
7. Economical requirements; cost of the equipments, maintenance, labor and time frame.

Objectives of groundwater control:

- Removing or Lowering of groundwater levels in the area by means of water abstraction; groundwater lowering or dewatering
- Reach a balance in groundwater pressure by applying a hydrostatic pressure in pipe, tunnel and caisson.
- Elimination of groundwater inflow to the area; ground freezing and grout curtain.

Dewatering systems applicable to different soils (Groundwater control methods):

1. sump pumping
2. wellpoint system
3. deep wells system
4. Electro-osmosis
5. Grouting
6. slurry walls
7. Freezing and
8. Tile drainage for permanent groundwater lowering levels.

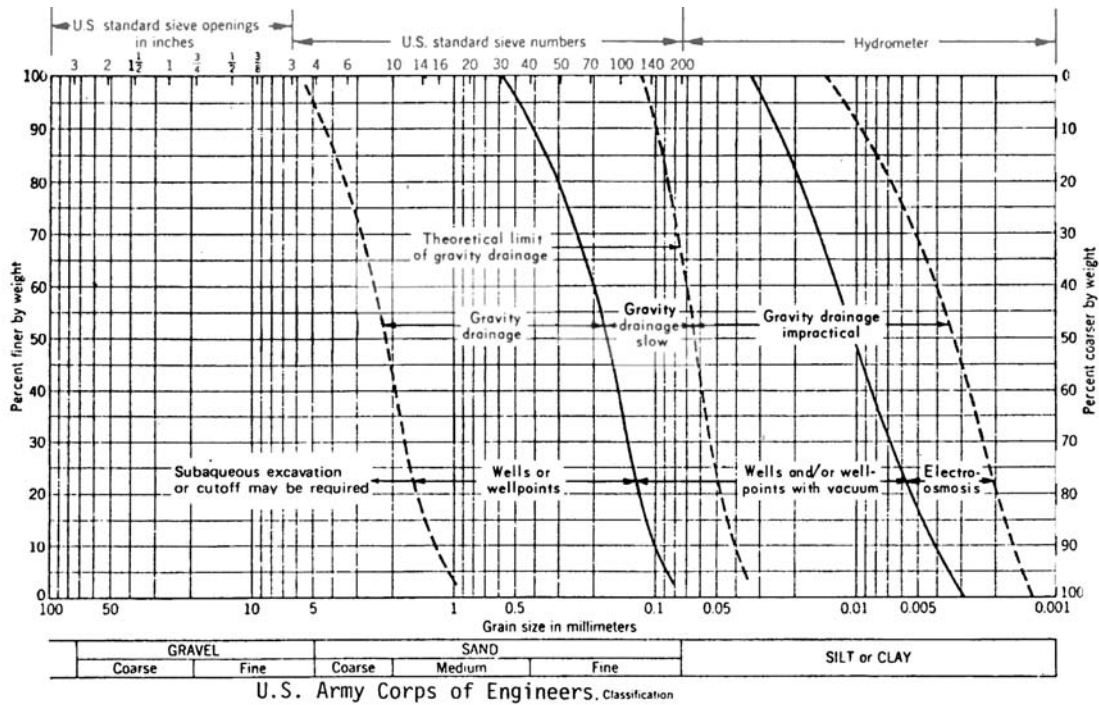

(Courtesy of Moretrench American Corp)

Figure 9: Dewatering systems applicable to different soils (Courtesy of the More trench Crop., Rockaway, N.J.)

Successful design of a dewatering system achieves the following:

1. Lowering groundwater table
2. Increasing stability of the side slopes of excavation which in turn reduce the excavation volume
3. Reducing hydrostatic pressure on sheeting walls and possibly allows lighter sections to be used
4. relief pressure of soils
5. Firming up soil in the excavation
6. Avoiding possible loss of fines and consequent settlement of nearby structures and
7. Considering consolidation effect in dewatering depth and rate.

i. Sump pumping

Sump pumping is applicable for open excavations in rocky and gravel soils. Ditches and sumps are installed within an excavation from which water entering the excavation can be pumped, fig.10. The depth of the sump ranges between 0,8 -1,5 m for small and large structures, respectively.

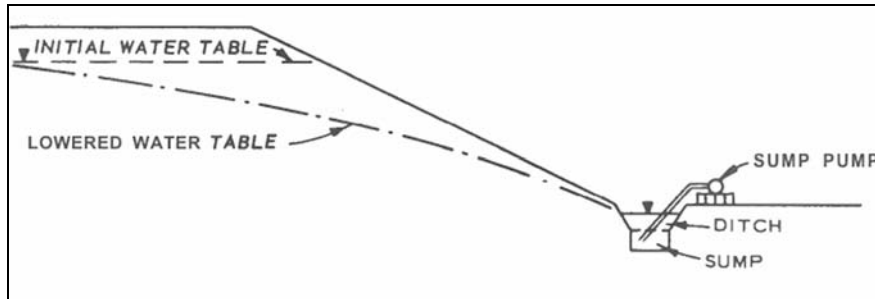

Figure 10: Dewatering open excavation by ditch and sump

After U.S. army (Modified from "Foundation Engineering," G. A. Leonards, ed., 1962, McGraw-Hill Book Company. Used with permission of McGraw-Hill Book Company)

ii. Wellpoint system(single stage or multi stage)

It is suitable for sandy soils and stratified clay soils. Wells are easy to install and very effective when flow velocity ranges from 1-100 m/day, rapid drawdown is required and groundwater table or artesian pressure needs to be lowered from 5-6 m (single stage wellpoint system), if greater drawdown is required multiple stage wellpoint system is used. Before the installation the groundwater table should be lowered to about 0,45 m in order to dry excavation area. One of the advantages of this method is that large quantities of water can be removed in short time.

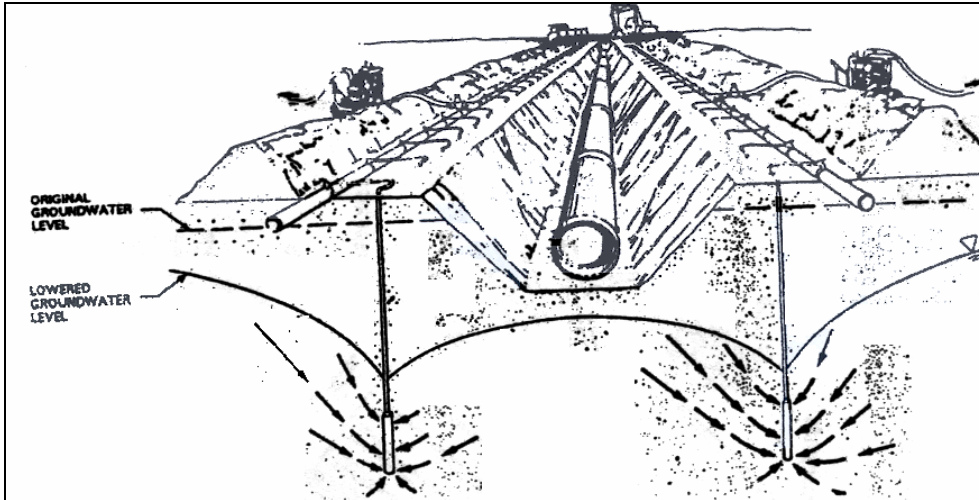

Figure 11: Wellpoint system-Layout for Trench Excavation (Groundwater and Dewatering handouts, El-Didy M.A. 2004)

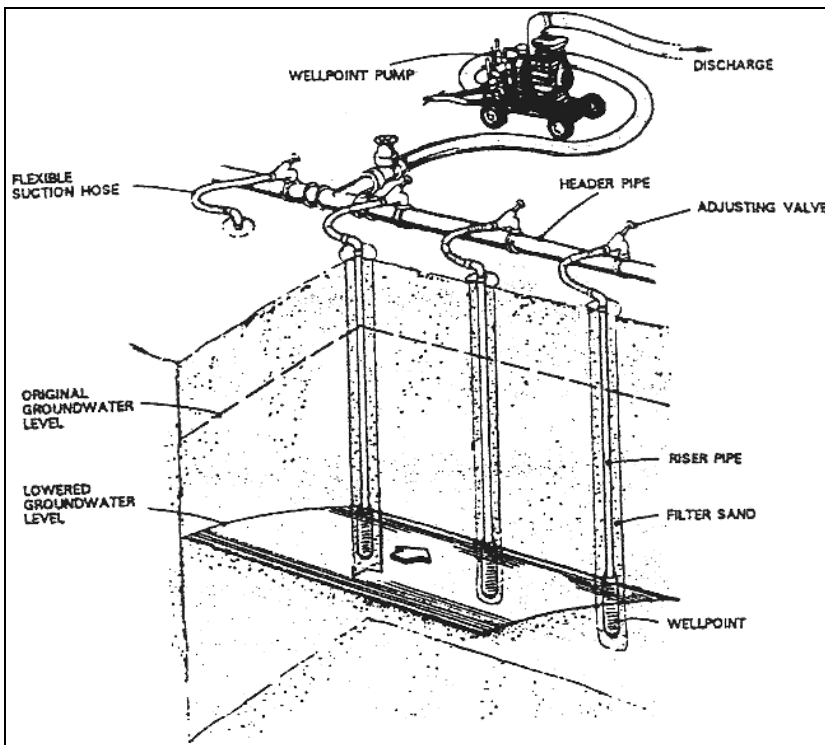

Figure 12: Wellpoint system-General Layout (Groundwater and Dewatering handouts, El-Didy M.A. 2004)

Figure 11 and 12 show wellpoint system installed alongside a trench or surrounding the excavation. They are joined to a common header pipe leading to one or more wellpoint pumps that discharge the pumped water. Some modification may be added to the wellpoint system to face different condition; if the soil condition is of a high permeable nature, a caisson system may be used or if the formation is highly stratified, filtered wellpoint is installed. An educator system can be installed in deep excavations in an impervious layer that multi-stage wellpoint system cannot be implemented.

iii. Deep wells system

Suitable for gravel to fine sands soils. Used with greater depth requirements (If water table is deep) where the depth is too great for wellpoint system or multiple stage wellpoint system is not feasible. Deep wells lower the water table and relatively less expensive than the multiple stage wellpoint systems for dewatering large areas. Figure 13 shows the uses of Deep wells, where they are used for deep excavations and pressure relief.

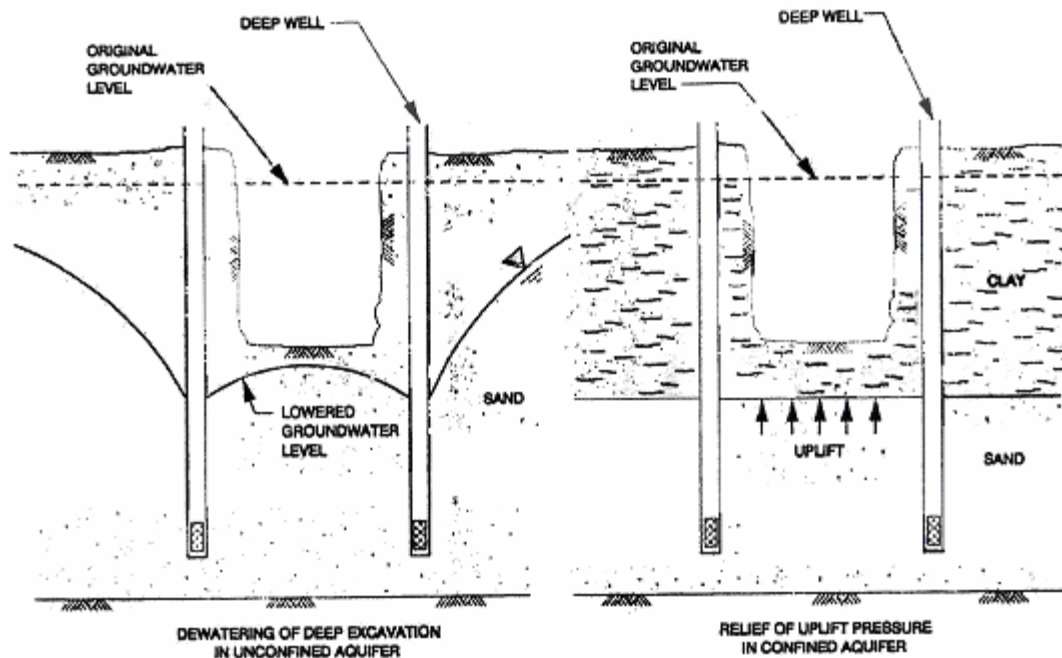

Figure 13: the uses of Deep wells (Groundwater and Dewatering handouts, El-Didy M.A. 2004)

iv. *Electro-osmosis*

This term describes the motion of a liquid through a medium as a consequence of the application of an electric field across the medium (figure 14). Therefore, dewatering is performed using electrical current. It is suitable for silty and clayey soils; since they are very difficult to be drained by gravity (wellpoint and deep wells systems are inapplicable). Clay soils have a net negative charge when an electric current is applied water migrates towards the negative electrode (cathodes). Hence, the area near the positive electrode (anode) dries. Electro-osmosis affects fluid velocity, see Figure 15. The velocity distribution changes rapidly near the particle's surface.

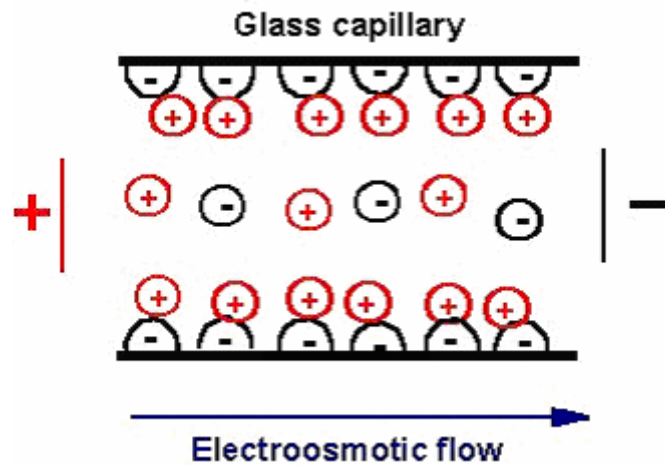

Figure 14: Dewatering of a fine-particled soil by Electro-osmotic.

(<http://elchem.kaist.ac.kr/vt/chem-ed/sep/electrop/graphics/electroo.gif>)

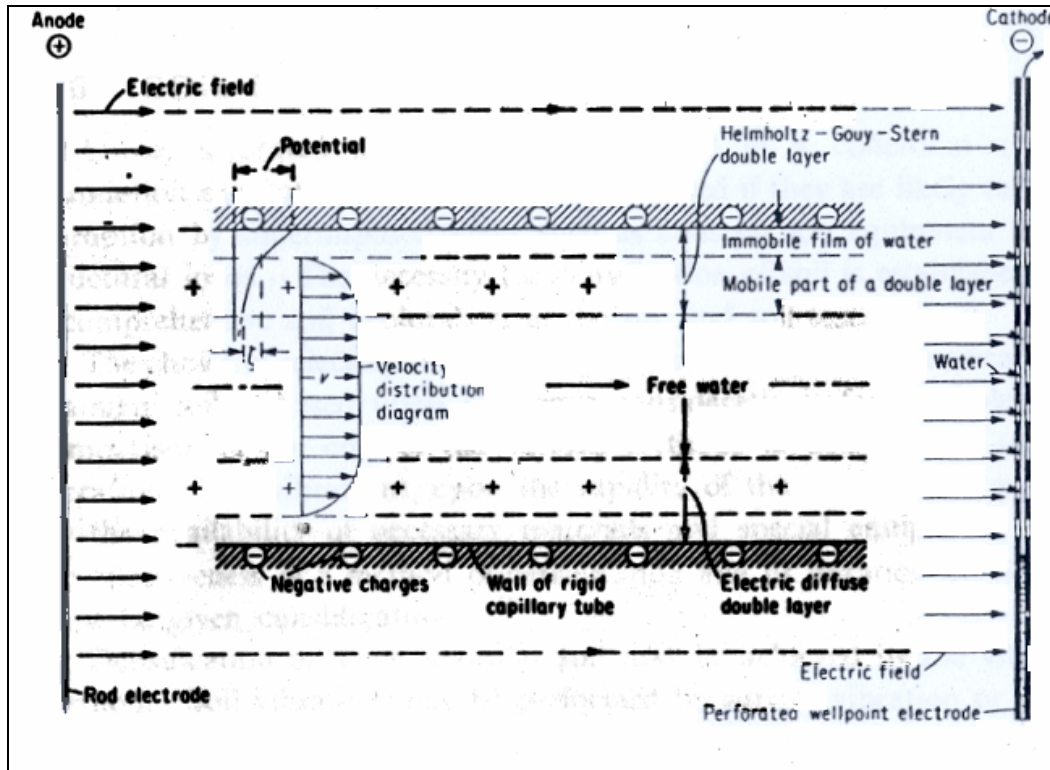

Figure 15: Electro-osmotic flow of water (Jumikis A.R., (1971))

v. Grouting

Grouting is an Injection to porous soils (figure 16). Hence, injection creates soil with high strength and low permeability. Grouting is used for most kinds of soils; from soft clays and silts to sands and gravel, regardless, soil type, permeability, grain size distribution.....etc.

Grouting method is cost-effective, quick to construct, does not need maintenance cost, does not affect the adjacent structures and cut down water seepage in the soil. High-pressure jet of grout; mixture of water, cement or Bitumen (hot bitumen or cold bitumen) is used for injection. Some chemicals may be added to accelerate the process e.g. sodium silicate or calcium chloride. The injection material close all the voids, spaces and cracks that cut off water seepage and increase the impermeability of soil.

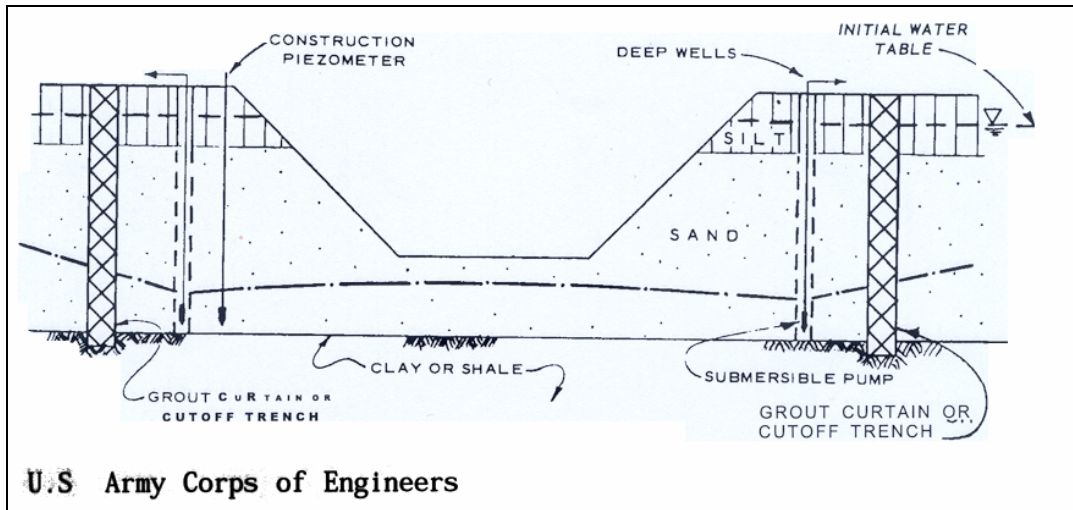

Figure 16: Grout curtain or cutoff trench around an excavation. (U.S. Army Corps of Engineers)

vi. slurry walls

Bentonite or Cement-Bentonite slurry walls are used to Control seepage through soils. slurry wall hinder groundwater flow in soil and cut down seepage, it acts like an obstruction wall. Slurry wall is a concrete wall that is constructed underground. Slurry walls do not hinder traffic in the construction area, cheap and long-term solution for groundwater problems. A trench should be dug to accommodate the walls and avoid side slopes collapse. It is of a great advantage if grouting is used with slurry wall since this combination will add more stabilization to the soil. Slurry which is a mixture of clay and water should have specific properties and undergo standard tests.

vii. Freezing:

Another mean of stabilizing and dewatering is freezing. The so-called 'ice-wall' is created by installing freezer points vertically or obliquely along the perimeter of the excavation site at a predetermined spacing (Jumikis A.R., 1971), figure 17. Freezer points absorb heat from soil to the freezing point. One of the advantages of freezing is salt transport which is very low near the freezing front, thus, salt accumulations are cut down.

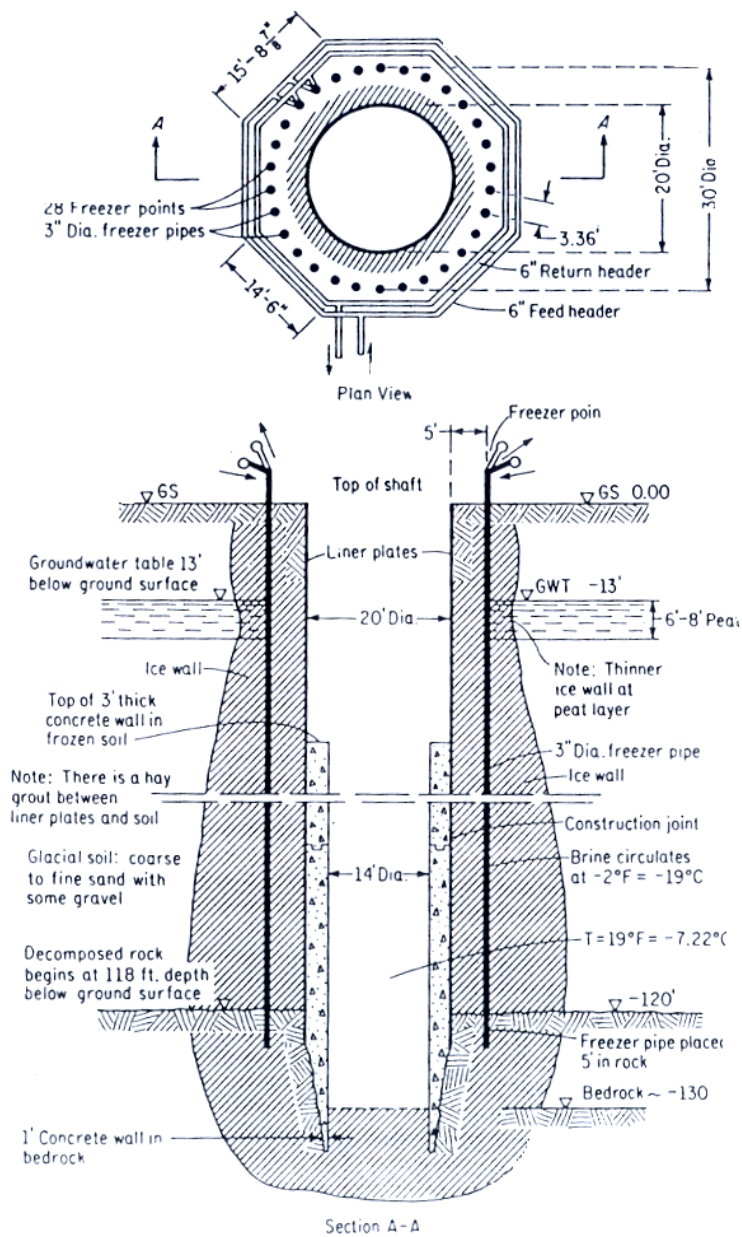

Figure 17: Artificial freezing of soil for a water-supply tunnel shaft (Jumikis A.R., 1971)

viii. Tile drainage for permanent lowering of groundwater levels

Subsurface drainage systems are either horizontal (tile drainage) or vertical (groundwater piping). Pipes are placed and arranged at suitable spacings and depths in the soil or subsoil to drain water from the soil. However, most drainage pipes today are made from perforated polyethylene; the term tile drainage which came from the material used before

to manufacture these pipes (concrete or clay called "tile") is still used until now. Tile drainage is considered to be very costly and used mostly on sandy soils. In some places, when tile system is introduced removing the whole existing drainage system is needed, however, after the construction, the system needs less labor, less energy to operate and less maintenance. Subsurface drainage has many advantages e.g. increase crop yields, reduce waterlogging in soil through draining excess water continuously, so that water does not remain in the root zone for several days and reduce loss of materials generally transported by overland flow. Therefore, irrigation water may be reused. Generally, subsurface drainage pipes are installed at a depth of 0,9-1,80 m. It worth mentioning, however, subsurface drainage is a very effective method to drain irrigation water, still there are some requirements in order to have an efficient drainage system e.g. geologic and soil conditions, land-use and sources and rates of irrigation, depth of groundwater table,...etc.



Figure 18: *Tile drainage* (source: www.cyber-diver.com/egypt_map.htm. last accessed on November 15th, 2006).

Chapter 3. Projects Review

In the previous chapter, effects of rising of groundwater levels, water related damage problems, irrigation schemes in Egypt and groundwater control methods have been discussed.

Warnings of the deterioration of many historic monuments in Egypt due to rising of groundwater level have addressed calls for urgent solutions and collaboration from all the national and international organizations. Generally, solutions require large amounts of money which the Egyptian economy cannot tolerate alone. Therefore, Egypt has addressed many calls to international organizations and specialists who are engaged in such problem to help in solving the problem. Rising of groundwater table is considered a serious threat to one of the World's greatest Heritage. However, the government has the will, it cannot accomplish what is required alone; the need is so great and requires support and active engagement of people everywhere.

For this, many countries co-operate with the Egyptian authorities through their organizations e.g. The Swedish Agency for International Development Cooperation (SIDA), The Oriental Institute of The University of Chicago, United States of America 'Chicago House', Government of the Netherlands, The Franco-Egyptian Institute, the World Heritage Centre in UNESCO, ...etc. SCA is responsible of all the Antiquities and historic sites. Ministry of Water Resources and Irrigation (MWRI), Research Institute for Groundwater (RIGW) are the main governmental agencies which are concerned with the problem. Cooperation is done through many ways e.g. transfer of knowledge and new technologies through international advisory bodies, help in projects implements, for example.

This chapter presents highlighting and illustration of methods used for lowering groundwater levels implemented in either finished or on-going projects in Egypt. Projects deal with threats to historic places cause by rise of groundwater levels and contribute to prevent the deterioration of the Egyptian Heritage.

The source of all the information in this chapter is taken from the report of each project.

General projects objectives:

The objectives of all the reviewed projects are to propose and implement solutions to lower groundwater levels in each chosen site. The following procedures were done in all the projects in order to achieve the main goal:

- Investigating hydrogeological conditions by means of collecting and reviewing of existing data.
- Field investigations which encompass:
 - i. Mapping and surveying to identify groundwater levels and groundwater flow direction.
 - ii. Drilling and Pumping tests to provide soil and water samples for laboratory analysis.
- Analyzing and modeling all collected data
- Proposing, designing and implementing a conceptual solution to lower groundwater levels in each chosen site.

3.1. Lowering groundwater levels at Esna, Abydos, Luxor and Karnak sites:

The four sites are situated in Upper Egypt, see figure 19. They encompass same hydrological features which are marked out from the hydrological investigation in the sties.

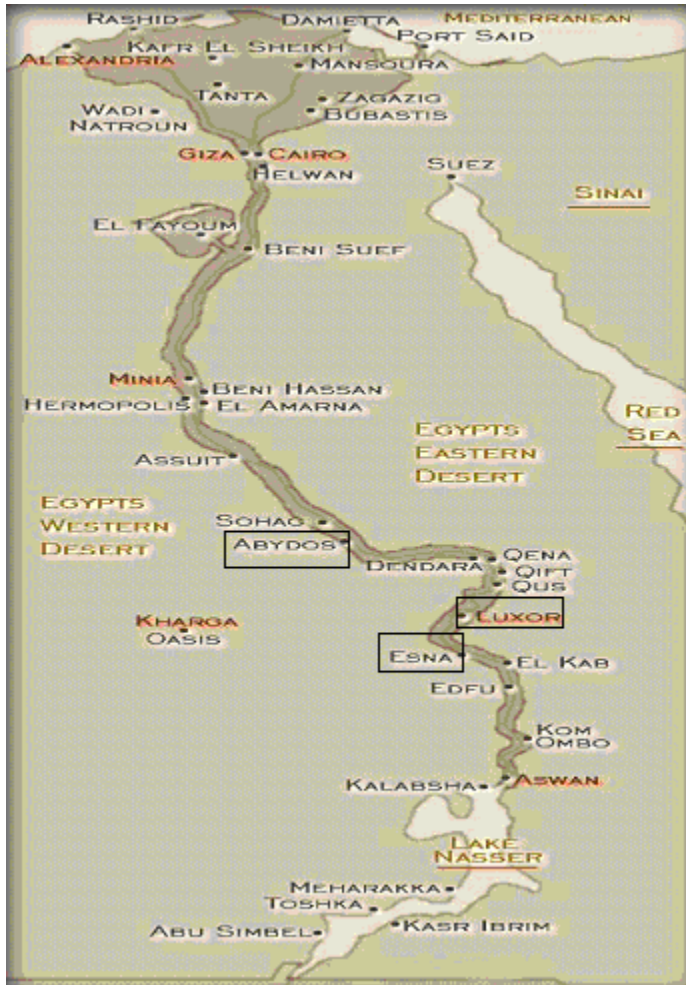

Figure 19: Map of Esna, Abydos, Luxor and Karnak temples (source: www.cyberdiver.com/egypt_map.htm)

Hydrological investigation along the Nile Valley

The climate is dry and hot. The topographical features along the Nile Valley are very much identical. The Valley is characterized by three geomorphic units (figure 20) 1) The Young alluvial plains which are underlain by Holocene silty-clay layer and contain the newly and old cultivated lands; 2) The Old Alluvial plains which are slightly higher than the Young plains. These plains are underlain by a mixture of Pleistocene sand and gravel which was formed from successive floods of the present Nile over the years (El Hossary, 1994) and 3) The Calcareous structural plateaus; the two extensive plateaus. They are made up of hard early Eocene limestone with high resistance against erosion with cliffs rising from the alluvial plains (El Hossary, 1994).

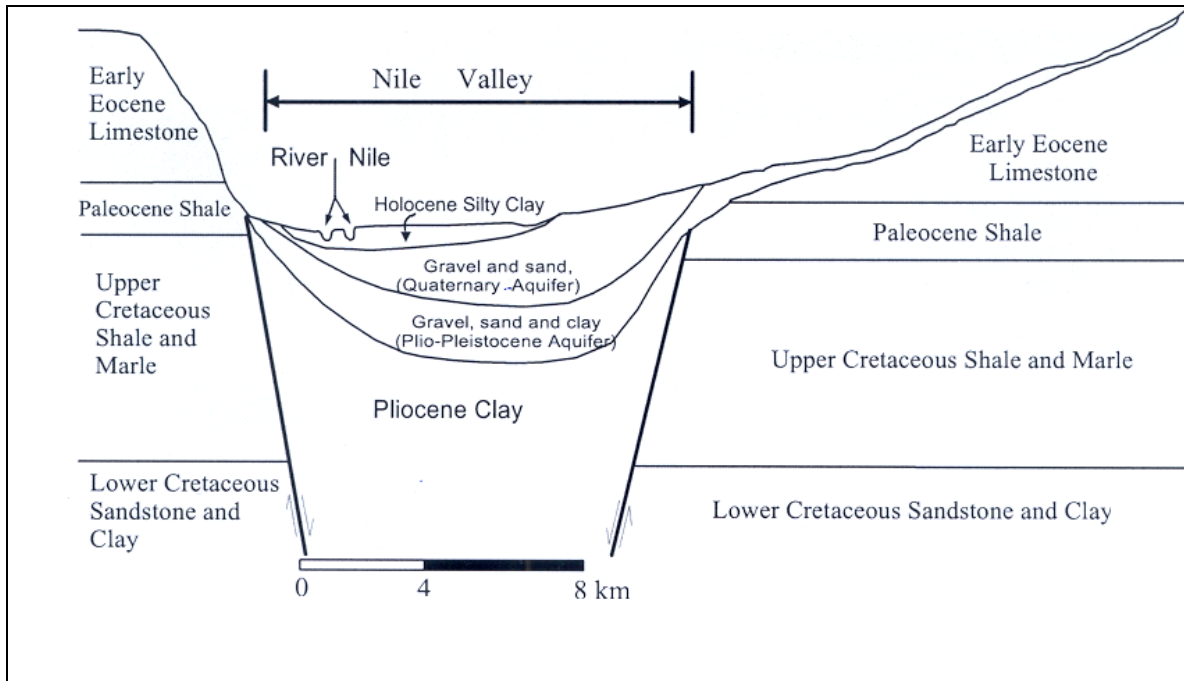

Figure 20: Hydro-geologic cross section at Luxor area showing the different lithological hydrologic units (RIGW, 1997).

The Nile valley is formed from deposited fine-grained soil which the flood has transported each year. The area is characterized by two major aquifers; 1) The Quaternary aquifer and the Plio-Pleistocene aquifer. The Quaternary aquifer is underlain by a silty clay layer that acts as semi-confined layer. It is made up of graded sand and gravel. On the banks of the Nile, where the silty clay layer terminates, the aquifer becomes phreatic. Quantitatively the quaternary aquifer can be defined as follow: a primary porosity of 25 to 30 %, a horizontal hydraulic conductivity of 75 m/day, a vertical hydraulic conductivity of 25 m/day and a transmissivity of 10, 000 to 20, 000 m²/day (Terhell, 1986).

2) The Plio-Pleistocene aquifer rests underneath the Quaternary aquifer with average thickness 60m. The Plio-Pleistocene aquifer is either phreatic or confined and is formed from sand and clay. The salinity of the Plio-Pleistocene aquifer is significantly higher than that of the overlying Quaternary aquifer (Ismail et al.).

Groundwater direction inside the Quaternary aquifer:

The flow direction differs from one place to another according to the topography. There is a local direction of groundwater for each site towards the River Nile.

3.2. Lowering groundwater levels at Hammam eloazeroon site in Adydos

The project is a co-operation between SCA, Egypt and RIGW, Egypt. Work frame, preparation, and site investigations for the site were done starting from 05/06/2003. The completion of the project was on 24/01/2004.

Many field trips were held for identifying and collecting the required information, surveying and drawing maps for the site, drilling of groundwater observation wells, geo-electrical investigations, collecting of soil and water samples, locate boreholes to determine groundwater and surface water levels and determine groundwater direction in the historic site.

Surveying

The site occupies 210 hectares surrounded by agriculture land and houses form all the sides except the northwest side where it is surrounded by mountains. The Site rests on phreatic aquifer area with no clay layer. Surveying results show that the area surrounds the site is situated at 78.4 m (a.m.s.l) while the bottom level of Hammam eloazeroon is situated at 62.6m (a.m.s.l) with original depth 9 m and the groundwater level is 63,7m (a.m.s.l), thus, it is clear that the bottom of the Hammam is lower than the water table in the phreatic aquifer which consequently rises water level in the bottom of the Hammam by 1-1.5 m during summer time. Groundwater could be seen on the Hammam's floor, this rise was recorded concurrently with the availability of irrigation water year-round and increase of human activities in the area of the Hammam after the erection of the AHD. It was observed that during winter (November-January) the site is totally dry owing to dryness of waterways around the site so that the waterways act as a drain for the area during winter. However, Drinking water network was introduced to the area in early 1990s, the area still lacks of sewage system and only uncoated septic tanks are used.

Soil mechanics work

Six boreholes with different depths are drilled at specified points around the site. Due to difficulties to drill in rock surface, mechanical drilling has been applied to extract soil samples for laboratory analyses. Field permeability test was carried out to identify the permeable layer which allows water infiltration. At the same time pumping tests were performed.

Geo-electrical survey

One of the ways in hydrological investigation is geo-electrical survey which identifies the stratigraphy of layers and hence, identifies ranges of soil layers that hold groundwater. SAS 1000_ABEM (Swedish made device) was utilized for field geo-electrical boreholes. Nine boreholes were made around the site with depth enough to reach the bottom of the Quaternary aquifer. Hemker software (program for drawdown calculations and inverse modeling (aquifer tests) of transient well flow in layered aquifer systems of (semi-confined, confined, and unconfined conditions) was used for data analyses.

Data analysis of groundwater problem in Hammam eloazeroon site:

Shallow and ground water levels recorded from piezometers readings showed that there is a significant change from winter to summer time. This change was very much noticeable in low groundwater levels and dryness of the site during winter. Water samples analyses showed high concentrations of salts dissolved in the water (between 920-3460 ppm). Traces of contamination of sewage water were observed from the microbiological test that showed that the total number of coliforms is 90 CFU/100ml and total faecal coliform is 50 CFU/100ml. Hence, it is very obvious that sewage from the houses drain off into the site area which, in turn, contributes to rising of water levels and eating away foundations of the buildings in the site due to the undesirable and adverse effects of sewage water components on stones and rocks.

Alternative suggested solutions

The project report discusses both short-term and long-term solutions to solve the problem. Long-term solutions help to attack and solve the problem at the source,

moreover, affect the regional hydrological regime in a try to minimize the changes have taken place during the past years, while short-term solutions solve the problem locally and is considered only as a temporary solution.

Long- term solution

Hydrological investigations and environmental studies show that rising in groundwater levels in the Hammam site resulted from introducing drinking water network in the area which recharged groundwater aquifers. Groundwater aquifers in the area are composed of sandy soil with high rate of permeability property. The proposed long-term solution that would lower groundwater levels under the Hammam is the implementation of well-designed sewage network that will prohibit leakage of sewage water to aquifers in the area.

Short-term solution

The proposed designed solution is pumping from the phreatic aquifer by deep wells system. It was found that the highest rising level of groundwater during the year on the Hammam's floor is 1, 2 m and hence, this amount is needed to be lowered. Sex wells are installed alongside surrounding the site with depths ranges from 30 to 60 m. Wells are joined together to a common header pipe leading to one or more pumps that discharge the pumped water in a nearby canal. To achieve the required drawdown to the site, a discharge of 20 m³/h for each well are required so that failure or settlement of the buildings is avoided. Operation of the deep well system will lower groundwater level at 61,5 m. The system was modified by adding a cut-off wall that will help to minimize the pumping rate which, in turn, prevent the occurrence of hydraulic decline towards the site, decrease energy costs and maintain a hydrological balance in the area.

Groundwater modeling

Short-term solution has been chosen for cost and time considerations. Groundwater modeling has been used to study the effectiveness and suitability of the proposed engineering solution. The model was run in steady state, calibrated and verified. After the model was verified, construction and implementation took place.

3.3. Lowering groundwater levels at Esna site

The project is cooperation between SCA, Egypt and RIGW, Egypt. Work frame, preparations and site investigations for the temple were done starting from 04/06/2003. The final report and completion of the project were on 20/01/2004. The project was implemented simultaneously with the preceding reviewed Abydos project. The procedures and the proposed solution of the two projects are considerably the same.

Surveying

The archaeological site is situated 250m away from the Nile in the middle of Esna city and 700m away from the new Esna barrage; The barrage was constructed on the river Nile in Esna, 90 km upstream Luxor city. The temple is built up of limestone. Houses are 3-6m away from the temple and surround the temple from all sides. Surveying results show that earth level around the temple ranges from 87-88 m (a.m.s.l) while the bottom level of the temple ranges from 80,1- 80,60 (a.m.s.l). Figure 21 shows groundwater levels in the temple area. It is clear that the floor of the temple is lower than the surrounding houses by 6-7 m which, in the absence of sewage network, allows any leakage from sewage water to recharge directly the groundwater aquifers resting under the temple. At the beginning of the 90s, wide expansions have taken place in agriculture land in Esna. The availability of water through year-round irrigation increase irrigation water (usually traditional basin irrigation) accompanied with the introduction of drinking water network have risen groundwater levels during the last twenty years.

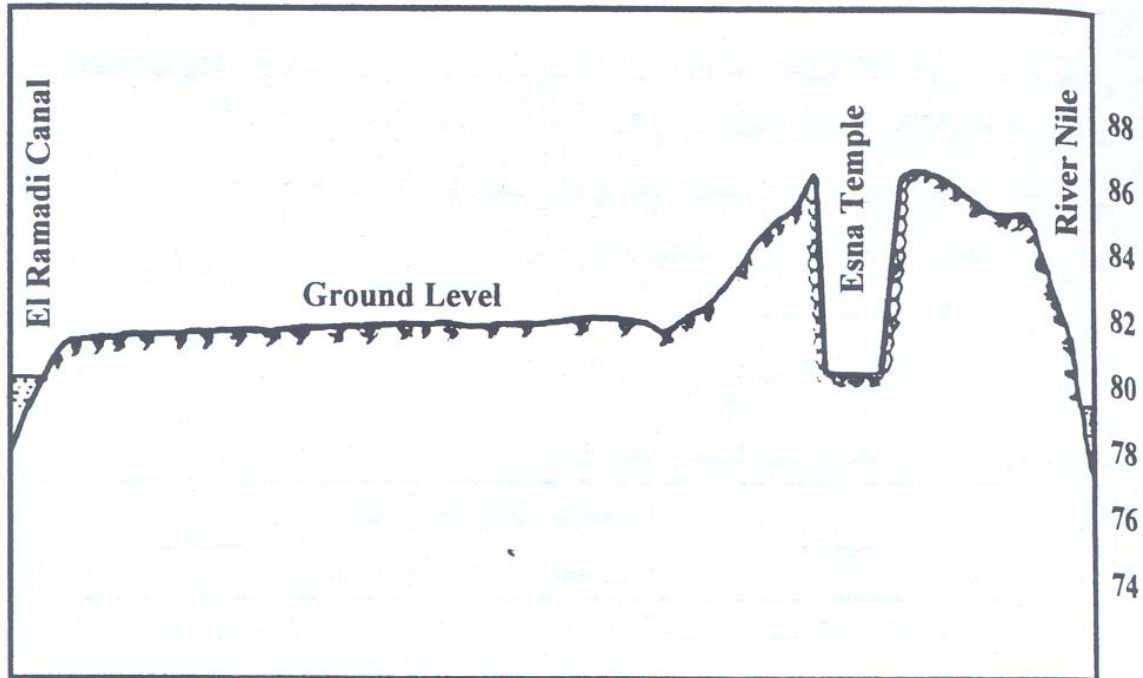

Figure 21: Groundwater levels in Esna temple area (project report)

The New Esna barrage, contributes to the rising groundwater problem as well. The Barrage has risen the water at 79 m height and maintains this height throughout the year, which definitely supplies the aquifer with water from the Nile. It was observed that the temple floor and walls were totally dry during winter. The level of groundwater is needed to be lowered by 1,5m so that the water level becomes below the water table in the aquifer.

Soil mechanics work

Five boreholes, see figure 22, with different depths are drilled at specified points around the site. Due to difficulties to drill in rock surface, mechanical drilling was considered to extract soil samples for laboratory analyses. Field permeability test was carried out to identify the permeable layers which allow water infiltration.

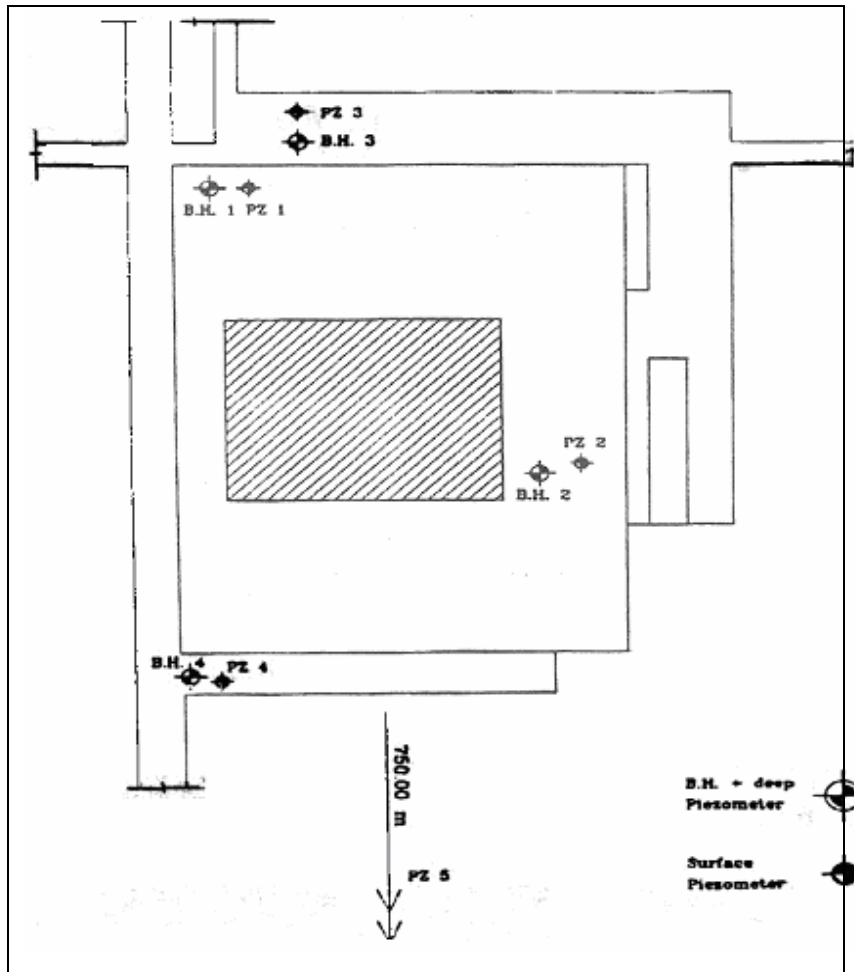

Figure 22: Five boreholes with different depths are drilled at specified points around Esna temple (project report)

Geo-electrical survey

SAS 1000_ABEM (Swedish made device) was utilized for field geo-electrical boreholes to identify the stratigraphy of layers. Seven boreholes were made around the site with depth enough to reach the bottom of the Quaternary aquifer. Hemker software was used for drawdown calculations, inverse modeling, and data analyses.

Data analysis of groundwater problem at Esna site

Shallow and ground water levels recorded from piezometers readings showed that there is a significant change between winter and summer. This change was very much noticeable in low groundwater levels and dryness of the site during winter. Water samples analysis

showed high concentrations of salts dissolved in the water range from 1000 to 4000 ppm. Traces of contamination from sewage water were observed from microbiological test that showed that the total number of coliforms 3×10^3 CFU/100ml and total faecal coliform 1×10^3 CFU/100ml. This is a straight indication that sewage from the surrounding houses drain off into the temple area which, in turn, contributes to rising of water levels and eating away the foundations in the site due to the undesirable and adverse effects of sewage water components on stones.

Alternative suggested solutions

To reach the desirable level of groundwater levels, the groundwater level is needed to be lowered by 1, 5 m from the current level so that the water level becomes below the water table in the aquifer.

The location of the temple has put some limitations on the proposed solution; the available spaces on the temple sides do not exceed 4 meters which do not provide enough area for mechanical work around the temple.

Long- term solution

The proposed long-term solution is the same as the preceding project of Abydos. Hydrological investigations and environmental studies show that rising in groundwater levels in the temple site resulted from introducing drinking water network in the area which recharged the groundwater aquifers in the area. Groundwater aquifers in the temple area are composed of sandy soil with high rate of permeability. The proposed long-term solution that would lower groundwater levels under the temple is the implementation of well designed sewage network that will prohibit leakage of sewage water to aquifers in the temple area.

Short-term solution

- Four meter depth and one meter wide ditch is constructed around the temple for drainage pipelines.
- The water is collected by 8 mm perforated P.V.C. pipelines connected to the collector in the two manholes.

- The ditch is coating with gravel filter and Backfilling.
- Collector pipeline of reinforced concrete along the collector pipeline, connected to the collector in manholes every ten meters
- Forty three wells installed every 8 m along the collector pipeline. Each well is 12” diameter and 14 m depth with 3 m screen and submersible pump that discharge 15m³/h. Water will flow into the collector to the manholes and
- One pumping station close to the Nile will lift water from the collector pipeline to the Nile.

Groundwater modeling

Short-term solution has been chosen for cost and time considerations. Groundwater modeling has been used to study the effectiveness and suitability of the proposed engineering solution. The model was run in steady state, calibrated and verified. After the model was verified, construction and implementation of the short-term took place.

3.4. Salvation of Karnak and Luxor temples

The project is cooperation between SCA, Egypt and SWECO International, Sweden. The agreement between the two sides was signed on November 2, 1999 after the Swedish International Development Cooperation Agency (SIDA) had agreed to contribute to the consultation services by SWECO International. Phase I of the project comprising supplementary field investigations, evaluation of proposed engineering measures. Phase II, which is still going on at the moment of writing this report; include the implementation of the proposed engineering solution. The construction costs for the propose solution are estimated to 24,200,000 and 4,520,000 Egyptian pounds at Karnak and Luxor temples respectively. Time needed for implementation is estimated to approximately 3 years followed by two years Defects Liability Period. It is worth mentioning here that there are many earlier investigations were done on the two temples.

- Traunecker (1970, 1971, and 1975) installed around 20 groundwater observation wells at Karnak.

- In 1997, The Research Institute of Groundwater (RIGW), performed a study to solve the problem and proposed an engineering solution.
- Geotechnical investigations in the area were performed for construction of water and wastewater facilities for Luxor (Camp, Dresser & McKee International Inc.,1997)
- In 1995, Orsacom; Egyptian consultancy firm, performed Pumping tests at Luxor Temple as a basis for the dewatering during the restoration of the columns of the second court of Amunhotep III.

Land use

Karnak and Luxor temples are located in the urban area stretching along the Nile. Luxor temple is located in the middle of the present Luxor city, surrounded by the Nile from one side, agricultural lands and houses from the other sides. Most of the cultivated lands are tile drained. The govern crop is sugar cane in the area.

During summer, the groundwater aquifer is recharged, hence, groundwater rises above the ground inside the temple by around 0,75 m. So, it is needed to reach a groundwater level of at least 2-2,5 m below ground within the temple area to avoid problems with transport of salts by capillary rise from the groundwater zone and minimize the risk of differential settlements. Clay in the temple areas is strongly over-consolidated.

Soil mechanics work

Two boreholes located north and south of Karnak Temple were drilled to 15 and 12 m depth, respectively. The groundwater levels recorded from the two boreholes on 25-04-2001 were at +72,57 and +72,60 m. Two boreholes located east and west of Luxor Temple were drilled to 23 m depth. The groundwater levels recorded from the two boreholes on 28-04-2001 were at +72,97 and +72,64m, there is 0,33 m gradient towards the Nile at Luxor Temple. Consolidation test at Luxor Temple shows that no consolidation settlement will occur when the groundwater table is lowered by 2 m. There will, however, be some movements because there is a load increase and the ground is elastic so reaction could take place according to Hook's law.

Data analysis of groundwater problem in Karnak and Luxor temples

Water samples were collected and analyzed at the laboratory of Alexandria General Water Authority. Generally, groundwater quality is very good in the area and drinking water standards are fulfilled in most of the samples. The TDS values are not very high but a very high value was obtained from the Sacred lake at Mut Temple 5988 mg/l, this could be explained as the lake acts as a sink for the groundwater due to the evaporation from the lake surface and therefore salts are concentrated in the lake. Iron and manganese are generally low, indicating high redox-potential, i.e. groundwater contains dissolved oxygen. No traces of contamination from sewage water were observed, though the number of coliforms was somewhat high in some samples. This is an indication that problems with monuments deterioration in the area are not due to high salt concentrations in the groundwater, but due to the salts accumulations on the monuments surfaces resulted from high rate of evaporation in this hot region.

The spatial and temporal distributions of irrigation water are not known in details. Furthermore, neither the evapotranspiration losses nor the distribution of leakage between drains and percolation are known exactly. No discharge measurements from drains were available for modeling which was considered as potential errors from the beginning of modeling.

Alternative suggested solutions

The goal is to reach a desirable groundwater levels from +71,5 to +72,0 m both at Karnak and Luxor temples respectively depending on the ground elevation. The proposed conceptual design is based on a combination of drains and wells. This alternative should give lower investment costs, but has been judged as less reliable. The exact relative effect of the drains and the wells depend on local conditions that not fully known. Furthermore, the alternative with only wells has to be based on pumping of each well.

Mechanical and electrical equipments will only be installed in the main pumping stations where monitoring of the operation and repairs will be easy.

Conceptual design at Karnak

A drain around the temple area with 12 wells drilled to deeper layers and one well with a submersible pump. The proposed solution has the following components:

- One 4,800 meter long collector pipelines constructed of reinforced concrete pipes located in the Chevrier Ditch (old drain surrounding the Karnak temple, used instead of digging a new drain to minimize costs and risk of new excavations near the temple).
- One 4,800 meter long drainage pipe along the collector pipeline connected to the collector in the manholes every one hundred meters.
- One 200 m long collector pipeline of reinforced concrete and a 200 m long drainage pipe along the collector pipeline, connected to the collector in manholes every one hundred meters along the Avenue of Sphinxes (which connects the two temples together). The excavations are underway and the collector is connected to the collector in the Chevrier Ditch.
- Twelve wells connecting the main aquifer with the collector. Water will flow by gravity from these wells into the collector.
- One well with a submersible pump located in the central part of the temple area.
- One pumping station, close to the Nile that will lift the water from the collector pipeline to the Nile.
- Isolation of the Sacred Lake.
- Backfilling of the Chevrier Ditch.
- Pumping station with a wet well is proposed to be built close to the Nile, where three pumps (2+1) with the capacity of 16 000 m³/d each. The pumps will start and stop automatically controlled by the level in the reservoir. From the pumping station, 600 mm outfall pipe of PE will be installed to the Nile.

The collector pipeline is designed to give, at high water level in the Nile, groundwater level of +71,5 m at the highest point and +70,5 m at the main pumping station. To achieve this, the internal top of the pipes shall be constructed with on average slope of 0,4 m per kilometer

The average maximum inflow of water from each well have been estimated to 1,800 m³/d and maximum inflow from drainage pipes to the collector pipeline is estimated to 200

m³/d the total flow was estimated to 31 100 m³/d (21 600 m³/d from the wells and 9 500 m³/d from the drains). The plastic perforated drain pipe (d= 150 mm) will be connected to the collector pipeline once every 100 m , which will give a peak flow in the drain pipe of 200 m³/d. In order to increase the contact between the drain pipe and the ground, backfilling will be done with crushed stone.

Manholes are installed at each point where the direction of the pipe is altered for future inspection and easy measurements.

Sacred lake

Since the groundwater levels obtained in the central area of Karnak Temple for the solution of combination of drains and wells are +70,7 to +71,5 m (approximately 2,5 m below the ground in the low-lying parts of the temple), depending on the season. Thus, the level in the Sacred Lake will be very low during winter. The bottom of the lake varies between +69,5 and +70,9 m. A proposal of a conceptual design for the isolation of the lake from groundwater by a tight bottom e.g. geomembranes was discussed from an aesthetical point of view and found acceptable. The solution with a drainage layer below the geomembrane allows emptying the lake for cleaning and other purposes. Cleaning in the lake is proposed to be performed manually.

Conceptual design at Luxor

For Luxor, a 750 m long drain with 5 wells is proposed. The collector pipe can be extended in the future along the Avenue of Sphinxes towards Karnak temple, if further excavations are made. The proposed solution has the following components:

- One 750 meter long collector pipeline constructed of reinforced concrete pipe.
One 750 meter long drainage pipe along the collector pipeline connected to the collector in the manholes every one hundred meters.
- Five wells connecting coarse layers in the ground with the collector. Water will flow by gravity from these wells into the collector.
- One pumping station, close to the Nile that will lift the water from the collector pipeline to the Nile.

- Pumping station with a wet well is proposed to be built close to the Nile, where two pumps with the capacity of 8 000 m³/d each. The pumps will start and stop automatically controlled by the level in the reservoir. From the pumping station, 400 mm outfall pipe of PE will be installed to the Nile.

The collector pipeline is designed to give, at high water level in the Nile, groundwater level of +71,0 at the highest point and +70,7 at the main pumping station. To achieve this, the internal top of the pipes shall be constructed with an average slope of 0,4 m per kilometer.

The average maximum inflow of water from each well have been estimated to 1 600 m³/d and maximum inflow from drainage pipes to the collector pipeline is estimated to 200 m³/d to each manhole. The total flow was estimated to 6 000 m³/d (4 800 m³/d from the wells and 1 200 m³/d from the drains).

The plastic perforated drain pipe (d= 150 mm) will be connected to the collector pipeline once on every 100 m, which will give a peak flow in the drain pipe of 200 m³/d. In order to increase the contact between the drain pipe and the ground, backfilling will be done with crushed stone.

Manholes are installed at each point where the direction of the pipe is altered for future inspection and easy measurements.

Groundwater modeling

For the numerical modeling, the software Visual Modflow version 3.0 was utilized. The model was run in the steady state, calibrated, and verified for each temple separately. The construction and implementation of the project are still going on until the moment of writing this report.

3.5. Lowering groundwater levels at Hawarah pyramid and Kiman Fares site

This project is cooperation between SCA and Irrigation and Consultancy Unit, Faculty of Engineering, Ain Shams University, Cairo, Egypt. The project started on December 12, 2002 and it is not mentioned when it was completed.

Hawarah pyramid and kiman Fares sites are located in Fayum governorate south of Cairo, Egypt.

Kimán Fares site

Surveying

The archeological site is located in the middle of an over-populated area. The site is lower than the level of the surrounding agriculture land and houses by 0,5-0,7 m. Thus, the possibility of leakage from sewage pipelines and irrigation is very high, especially that, basin irrigation, which needs a huge amount of water, is practiced in the area. Salts crystallizations are very obvious to the eye on the ground; in some places salts accumulate forming layers of salt. It is worth mentioning that, groundwater problem in the area is not new but it has existed for a long time.

Soil mechanics work

Five boreholes with 15 m depth are drilled at specified points around the site. Soil samples have been analyzed at Faculty of Engineering, Ain Shams University laboratory. The soil was found to be loamy clay include some fine sands. Permeability test was carried out and the average permeability was found to be round $9 \cdot 10^{-8}$ km/min.

Hawarah pyramid

Surveying

However, the Hawarah pyramid is located south of Fayum in a mountain area away from the city and the site is far from any drinking water pipelines or sewage network, New agricultural reclamation projects are taking place not so far from the pyramid that will use water from canal called Wahbi Canal nearby the site with water level +90, 00, the difference between the pyramid surface and the Wahbi Canal is 8 m.

Soil mechanics work

Ten boreholes were drilled; 6, 1, 1, 1 and 1 boreholes with 15, 16, 14, 20 and 25 m depth, respectively, according to the change in ground elevations. The soil was found to be loamy clay with some fine sands. Permeability test show that the average permeability is around $7 \cdot 10^{-8}$ km/min.

Geo-electrical survey

Schlumberger geo-electrical arrays device was utilized for field geo-electrical boreholes to identify the stratigraphy of layers.

Alternative suggested solutions

Kimán Fares site

Perforated polyethylene pipeline was proposed to be constructed along the site with 2,5 m depth. The pipeline is connected with a collector pipeline. Water will flow into the collector and then to the submersible pump that is located in the pumping chamber and thereafter the pump will lift water from the collector pipeline and discharges the water into manholes.

Hawarah pyramid

First alternative

The proposed conceptual design is based on deep wells system. Thirty wells with 30 m depth are installed along the pyramid. The space between each well is 16 m with total of 500 m diameter. The diameter of each well is 8 inch. The Pumping discharge is 6 l/sec. The pumps will start and stop automatically controlled by the level in the reservoir; if the level exceeds +80, 00, pumps will start working. Finally, water collected is lifted and drained off in the Wahbi Canal.

Second alternative

The second proposed solution is based on constructing a wall made from a mixture of concrete-Bitumen. The wall thickness is 60 cm and deep enough to reach the upper layer of the underlying aquifer with 50 cm penetration into the aquifer to make sure it is well fixed. The wall is to be constructed along the pyramid to prevent seepage towards the pyramid structure. Five wells with 30 m depth are installed along the pyramid and the wall to pump any water bounded in the wall area. The Pumping discharge is 6 l/sec. The pumps will start and stop automatically controlled by the level in the reservoir; if the

level exceeds +80,00, pumps will start working. Finally, water collected is lifted and drained off in the Wahbi Canal.

Groundwater modeling

For the numerical modeling, the software Visual Modflow was utilized. Calibration for all the proposed solutions were done and verified.

3.6. Lowering groundwater levels at El-Shatbi tombs

This project is cooperation between SCA and RIGW. The project started on April 22, 2003 and it is not mentioned when the project was completed. Field investigations started in June, 2003 until August, 2004 to identify the causes of the problem. Field investigations took fourteen months to be ready due to administrative obstacles and routine that the executive body had to take permissions from eleven different authorities before the beginning of work.

Surveying

The archeological site is located on the Mediterranean coast in Alexandria Governorate, north of Egypt. The tombs were built in 260 B.C. for burying members of rich Greek family after their death .The bottom of the tomb lays 0,5 m (a.m.s.l.), while ground surface around the site are at 5,293 - 7,647 m (a.m.s.l.).

Soil mechanics work

Six boreholes located at different points were drilled at depths that ranges from 18 to 25 m. S.P.T test were carried out in the field on the unconsolidated soil samples. Other tests were carried out in the laboratory; hydraulic conductivity test was done by using Guelph Permeameter device.

Geological survey

SIR10-HGPR radar was utilized for geological boreholes to identify the stratigraphy of layers. The site was divided into 44 sections with total length of 380m and 16 m deep to determine groundwater levels and thickness of the aquifer layer.

Data analyses of groundwater problem in Shatbi tombs

The highest water level recorded in the period from 20/12/2003 to 14/1/ 2004 was 1,4 m (a.m.s.l.) in the rainfall season, while the lowest level was 1,11 m (a.m.s.l.) on 4/3/2004. Water samples were collected and analyzed at the laboratory of the National Center for Water Studies. Water samples analysis showed high concentrations of salts dissolved in the water around 2500 ppm, this could be explained due to the nearness of the site to the Mediterranean sea. Microbiological test that showed that the total number of coliforms was 126×10^2 CFU/100ml and total faecal coliform was 20 CFU/100ml, owing to contamination from sewage water due to leakage from sanitary pipes which, in turn, contribute to rising of water levels and existence of permanent humidity inside the tomb which affect the paints and the foundations of the tombs.

Alternative suggested solutions

It was very important not to close the tombs during the work, as it is considered to be an important touristic area in Alexandria. Groundwater level are needed to be lowered 2 m to make sure that no settlement takes place and the floor of the tombs remains dry.

Long-term solution

The proposed conceptual design is based on designing and implementing a sewage network under the tomb. Perforated polyethylene pipeline is proposed to be constructed along the site. The pipeline is connected with a collector pipeline. Water will flow into the collector by gravity or a submersible pump located in the pumping chamber, then the pump will lift the water from the collector pipeline to manholes or the sea depends on the design. The network depth were calibrated in three depths 30, 40, 50 m which will discharge 16, 22, 31 m³/h, respectively.

Short-term solution

Limitations due to the unavailability of space for any Mechanical and electrical equipments limited the choice of the solution. Some scenarios were suggested but the suitable one is based on, installing four wells along the site which will give 35 cm

drawdown and discharge $60\text{m}^3/\text{h}$ to manholes located nearby. This solution will cause settlement in the tombs' floor ranges from 0,2 to 0,9 mm and 0,6 to 1,0 mm to the neighboring buildings. But this settlement will not affect the stability of the tombs.

Groundwater modeling

Short-term solution has been chosen for cost and time considerations. EXCEL and GIS have been used to study the effectiveness and suitability of the proposed engineering solution. The proposed solution was calibrated, verified and implemented.

Chapter 4. Discussion

Generally, as described in chapter three, the used methods in Egypt for lowering groundwater levels and consequently, saving the archeological sites from groundwater threats, promote short-term solutions only. As mentioned in the preceding chapters, there are many reasons that contribute to the rising of groundwater levels problem. The short-term solutions, however, solve the problem, they are still temporary solutions. Short-term solutions do not attack the problem at the source. It is very clear that the methods used are more or less the same; some of other groundwater control methods have not been proposed or analyzed, the question is how the applicability, efficiency and feasibility of different methods could be known without careful analyzing. Furthermore, long-term solutions have been discussed (in details in some projects while they were just mentioned in others) they have not been analyzed thoroughly. Moreover, none of these long-term solutions dealt with over-irrigation problem or improving irrigation methods.

Irrigation, not only, contributes to rising of groundwater elevations with a big share, but it contributes to the increase of both groundwater and surface water salinity as well. In order to alleviate the problem of groundwater salinity, more efficient irrigation management is required combined with effective drainage system, which has not been discussed in the reports of the projects. It is, not even, mentioned or documented how much of irrigation water recharges into the aquifers and why this water is not reused so that we get use of it instead of having this water as a burden and lose it.

Sustainability of the implemented projects is an issue that should be discussed deeply. Most of the chosen methods do not offer long-term protection. Moreover, these proposed methods have some disadvantages, e.g. costs are very high (electricity, operating personnel, maintenance,.....etc.), do not address solution to the problem at the source and high risk of system failure or interruption due to bacteria growth develops in the filter system or cut in the electric current (this even happened during the field trip in Alexandria where the main pumps stopped and groundwater raised to above the ground surface within 4 hours while the standby pumps were not working due to problems in maintenance). Furthermore, none of the reports mentioned what are the impacts of this intensive mechanical work on the stability of the monuments or who is responsible of the follow-up to these projects on the long run since the continuous pumping of water from

the ground brings up fine particles from the underlying soil. Consequently, the ground shifts to compensate for the missing particles that are sucked up with the water, destabilizing the walls and foundations of buildings.

In order to reach long-term sustainable solution, permanent lowering of groundwater levels must be achieved. Long-term solutions, however, might need high investments that the Egyptian's economy cannot afford, they are the most effective solutions to the problem from the core, and in addition, they are definitely cost-effective solutions. On the other hand, the implementation of temporary short-term solutions need high investments too but they are neither attack the problem source nor very efficient or cost-effective on the long run.

It would have been more effective if this money was invested in long-term sustainable solutions like the project of protection of the great Sphinx of Giza in the early 1980s. When the government provided a sewage system for the neighboring village, the water table below the Sphinx dramatically dropped down 9 meters below the surface and the salts stopped their intrusion. It has been the same since then.

Agricultural development after the erection of the AHD is questionable and should be revised from the beginning. The furious need to feed the exploding population make the Egyptian government very keen to supply more land for crop growing to feed and house the people. As a result of this development, the water regime is now unbalanced and the water table of the entire country has dramatically risen in the last thirty years.

Irrigation schemes and practices need to be revolutionized at least to minimize the problem. In parallel, a design of permanent drainage systems which include provisions for inspection, maintenance, and monitoring the behavior of the system in more details should be implemented. Tile drainage and surface irrigation should be considered since they are very good management tools for irrigation water and very cost-effective, however, they are not used on a wide scale.

Raising Public awareness is not documented or discussed at all by the consultants who conducted the reports. During the field trips, it was very obvious that locals do not know what is going on in the sites and what the problem is. Farmers keep using the old irrigation techniques without guidance from the authorities. The question is why the state

does not deal with the problem and raise the public awareness, generally, and farmers' awareness, particularly.

Water has adversely affected a big share of the world heritage sites and instead of funding short-term solution with questionable efficiency and sustainability. It is better to put these funds in the right place which will provide sustainable rescue for the so called earlier 'indestructible' historic heritage that once stood in dry sand but now are bathed in water throughout the year and limestone and sandstone are gradually crumbling back into sand and destroying a splendid civilization that might not remain for the future generations and even might disappear in our lifetime.

Chapter 5. Conclusions and recommendations

The purpose of this thesis was to investigate the methods used to eliminate the increase of groundwater elevations.

Generally from the previous chapters, causes of this increase in groundwater table can be concluded into the following:

- The construction of the Aswan High Dam which consequently affected the groundwater regime along the Nile.
- Reclamation projects close to the archeological sites and over-irrigation accompanied with the absence of effective drainage network
- Irrigation methods used, which is usually traditional basin irrigation that based on usage of great amount of surface water.
- Potential seepage from sewage systems (if exist), septic tanks and drinking water networks.
- Digging canals and ditches near the archeological site since these canals and ditches unbalance the existing water system.

Recommendations

- Encouraging and highlighting the advantages of long-term sustainable solutions. However, the methods implemented appear to be feasible; they should not be taken as granted. In addition, it is very important to minimize mechanical work in the historic areas.
- Improving on-farm water management by limiting basin or garden irrigation which discharge big amount of water. This could be achieved by putting irrigation practices of small farms under control.
- Promoting more advanced irrigation practice, e.g. tile drainage, surface irrigation which are considered to be good management practice, in parallel with minimizing other old practices, e.g. basin irrigation, furrow irrigation ...etc.
- Improving drainage water reuse instead of pumping drainage water back to the Nile.

- Raising Public awareness, especially, farmers' awareness about water-related problems and explain the threats of groundwater on the monuments.
- Promoting water users' associations (WUAs) as effective partners in irrigation management.
- Involving different consultants and advisory bodies with different backgrounds who are concerned about the problem, which in turn, will enrich the proposed solutions to the problem instead of having the same expertise that use the same solutions more and more without any improvement or proposing new technologies.
- Address calls to the international society to cooperate and get involved with the Egyptian government to solve the problem and consider it as an international obligation.

References:

- Abu Zied, Mahmoud (1992) *Water Resources Assessment for Egypt*. Paper presented at Roundtable on Egyptian Water Policy, Alexandria, Egypt, April 1992, p.14.
- Ahmed Ismail, Neil L. Anderson, J. David Rogers, Abbas Mohamed Abbas, Estella A. Atekwana. Hydrogeophysical Investigation at Luxor, Southern Egypt.
- Childs, E. C. (1969) *An introduction to the physical basis of soil water phenomena*, John Wiley and Sons Ltd., London, 493 pp.
- Coward, E.W. Jr. (1983) *New Directions in Irrigation Research and Development*, in: W.F. Whyte & D. Boynton (Eds), *Higher-Yielding Human Systems For Agriculture* (Ithaca, Cornell University Press).
- IIP (1993b) *Water Management Monitoring and Evaluation Program By R. Oad and S. Mohamed (Cairo, Egypt)*.
- Jumikis A.R., (1971) *Foundation Engineering*, Rutgers University, The state University of New Jersey.
- Robenson, M. and Ward, R. C. (1990) *Principles of Hydrology*, third edition.
- Samaha, M. Abdel Hady (1979) *The Egyptian Water Plan (Water Supply & Management, Vol..*
- Terhell, K., 1986 *Detailed hydrogeological mapping of the Eastern Nile Delta*. Internal report RIGW/IWACO, 38pp.
- Lohman, S. W. (1972) (chairman) *Definitions of selected groundwater terms*.
- Abu-Zied M. and Abdel-Dayem S., (1993), *Agricultural Drainage Water Reuse in Egypt*. Paper.
- Wind, G. P. (1961) *Capillary rise and some applications of the theory of moisture movement in unsaturated soils*, in *TNO Committee fro Hydrological Research. Proceedings and Information No.5*, Wageningen , pp. 186-99.
- Shaw, Elizabeth M. (1983) *Hydrology in practice*.

- Høybe J. (2005) *Assessment of water related damages and adverse effects on historic monuments, Mission to the World Heritage Sites at Ancient Thebes and Abu Mena, Egypt. UNESCO, Report.*

<http://www>

http://www.cyber-diver.com/egypt_map.htm. Last accessed on November 15th, 2006

<http://www.cia.gov/cia/publications/factbook/geos/eg.html>. Last accessed 2 Oct, 2005

<http://www.mywiseowl.com/articles/Egypt>. Last accessed 2 Oct, 2005

<http://www.sjd.water.ca.gov/drainage/groundecmaps/index.cfm>. Last accessed 2 Oct, 2005

<http://www.umich.edu/~kelseydb.html>. Last accessed 2 Oct, 2005

<http://elchem.kaist.ac.kr/vt/chem-ed/sep/electrop/graphics/electroo.gif>. Accessed on 25 February, 2006