



**SCHOOL OF AVIATION**  
Lund University

15/03/2005

# **The Head Up Display Concept**

**A Summary with Special Attention to  
the Civil Aviation Industry**

**Author:** Anders Ingman  
**Class:** 03:2  
**Supervisor:** Rolf Lund

## **Abstract**

This paper is a literature study of the Head Up Display (HUD) in general with focus on the HUD's role in the civil aviation industry in particular. The objective is to present the history of the HUD in brief, summarize the basic design, describe the HUD's role in today's civil aviation and present the HUD in a human factors concept. This includes describing the human information processing behavior and human spatial disorientations concerning instrument scanning techniques and the most common sensory illusions experienced. There is also a summary of HUD symbology in different phases of flight.

Some of the main sources of information have been Richard L. Newman's book "Head Up Displays: Designing the Way Ahead" (1995) and Stoke's "Display Technology" (1990).

The main conclusion is that the HUD aids the instrument scanning process in phases of flight with high workload, such as take off, approach and landing resulting in increased situational awareness, flight precision and flight safety. It also provides airlines with a cost effective alternate in reaching low visibility operations.

## Table of Contents

<b>1</b>	<b>Introduction</b>	<b>1</b>
<b>2</b>	<b>Purpose</b>	<b>1</b>
<b>3</b>	<b>Limitations</b>	<b>1</b>
<b>4</b>	<b>Method</b>	<b>2</b>
<b>5</b>	<b>An Introduction to the Field</b>	<b>3</b>
5.1	The Definition of the Display	3
5.2	The Display in Brief	3
5.3	The HUD in Common Focusing	3
<b>6</b>	<b>Scanning Techniques</b>	<b>4</b>
6.1	Reduced Dwell Time Equals Increased Situational Awareness	4
6.2	Serial Processing and Parallel Processing	4
6.2.1	Serial Processing	4
6.2.2	Parallel Processing	4
<b>7</b>	<b>Spatial Disorientation and Sensory Illusions</b>	<b>5</b>
7.1	Spatial Disorientation	5
7.2	The Black Hole Effect	5
7.3	Shape Constancy and Size Constancy	5
<b>8</b>	<b>Problem Areas Aided by HUD in Approach and Landing</b>	<b>6</b>
8.1	The Visual Approach	6
8.2	The Transition from IMC to Visual Landing	7
8.2.1	The Klopstein Runway	7
<b>9</b>	<b>A Historical Review</b>	<b>7</b>
<b>10</b>	<b>HUD Technology</b>	<b>8</b>
10.1	The Cathode Ray Tube	8
10.2	The Refractive HUD	9
10.3	The Reflective HUD	9
10.4	System Architecture	10
10.5	Display Clutter	11
<b>11</b>	<b>The Purpose of the HUD in Civil Aviation</b>	<b>11</b>
11.1	Southwest Airline's Experience	12
11.2	Alaska Airline's Experience	12
<b>12</b>	<b>Today's System</b>	<b>12</b>
12.1	Flight Dynamics Head Up Guidance System (HGS)	12
12.2	Evaluation of HGS Symbology	13
12.2.1	HGS During Take Off Roll and Take Off	13
12.2.2	HGS Aid in Recovery from Unusual Attitudes	14
12.2.3	Surface Guidance System (SGS) and Symbology	14
<b>13</b>	<b>Possibilities of Future CAT IIIB Certification</b>	<b>15</b>
13.1	The "Hybrid" CAT IIIB	16
<b>14</b>	<b>Conclusion</b>	<b>17</b>
<b>15</b>	<b>References</b>	<b>18</b>

## **1 Introduction**

My interest in this field was obtained in the cockpit of a domestic flight with Scandinavian Airline System (SAS) in the fall of 2004.

The technology around us is constantly improving. Far gone are the days when the human being wasn't the weakest link in a high technology system.

In the civil aviation industry the cockpits are becoming automated. The pilot is more and more becoming a system monitorer. His task revolves more around coping with abnormalities in system behavior than actually flying the aircraft. With technology improvements the role of the pilot is more and more questioned, but are his days numbered? Technology development in reducing human error bringing the pilot "back in the loop" by increasing his situational awareness in critical phases of flight is improving and the HUD system is playing a big role.

In analyzing statistics, flight crew errors are the primary cause of aircraft accidents and the most specific cause is loss of directional control during intermediate and final approach. The need to increase the pilot's situational awareness in these phases of flight was the main purpose with the development and introduction of the HUD system into the civil aviation industry.

## **2 Purpose**

The main objective of this paper is to present an introduction to the field for the novice reader and to describe the role of the HUD in today's civil aviation industry.

The HUD concept saw daylight for the first time in the 1950's. Up to the mid 1980's, HUD has been a system used in military aviation exclusively. Today the HUD has found its way into civil aviation being installed in several of the world's major airline fleets.

The main question I seek to answer is the purpose of the HUD concept in the civil aviation industry. In the JAA ATPL-license literature I have found a lack of information regarding the HUD and this also serves as a reason for why I see a need to further expand the knowledge of this concept to a broader front.

## **3 Limitations**

In researching material for this study I found tremendous amounts describing the HUD technology and concept in complete detail. I therefore quickly saw a need to limit the material utilized to find a balance between depth and width.

In order to appreciate the HUD concept it is essential to build knowledge of human information processing behavior as well as human spatial disorientations. In this paper the focus will be on describing human instrument scanning techniques, the most common sensory illusions experienced and their implication in the HUD concept.

The main objective is to present an introduction to the field for the novice reader and then to describe the role of the HUD in today's civil aviation industry.

To fully appreciate the HUD concept, describing HUD symbology in different phases of flight will then provide some further depth.

## 4 Method

The method used for this paper is literature study. The material utilized consists mainly of books and electronic articles. The electronic articles have been found via the Electronic Library Information Navigator (ELIN) accessible via Lund University, Sweden, with which it is possible to search most of the world's scientific journals for articles. In order to find books concerning the subject I used another search engine called "LIBRIS" where all books in all Swedish libraries are listed. The Internet search engine "Google" have been used to search homepages.

The most important source of information have been Richard L. Newman's book "Head Up Displays: Designing the Way Ahead" (1995), which is a complete guide to the field. In this book Newman presents a historical review, discusses the HUD technology and design, evaluates present HUDs and recommends fields for research in the future. This book was however not attainable via the "LIBRIS" search engine but was very kindly lent to me via the Lund University School of Aviation (LUSA) and the Swedish Defence Research Agency (FOI).

When describing HUD symbology in different phases of flight I used the Rockwell Collins Flight Dynamics Head Up Guidance System (HGS) as reference model. This is because of the wide use of this system in the civil aviation industry [7].

## **5 An Introduction to the Field**

### **5.1 The Definition of the Display**

The word display has several meanings. In everyday English, the word “display” refers almost exclusively to visual information. A display can be a show, as an air display or an exhibition. It can also be a roadside sign seen through a car’s windshield or a commercial poster. The perceptual landscape that meets the senses is a dynamic three-dimensional color-pictorial display [1]. In this paper we will discuss the HUD concept and the restricted definition of a display chosen will be “*a display presents the status of a man-machine system*”.

### **5.2 The Display in Brief**

Throughout history research and development of display technology have played an important role in the aerospace industry. Since flying places great demands on human information processing capabilities the “cutting edge” of display research has tended to reside in the field of aviation. Many of the insights gained in aerospace research relate to basic human information processing and the technique developed have therefore many times found its way in to automotive, naval and industrial applications [1].

Displays can access far more information than is available to direct observation and can overload the human operator with more parameters than can be processed and integrated, i.e. vast amounts of information resulting in “information overloading” and “display clutter”. Equally, displays can restrict the information needed to solve a task and then become “data limited”.

Balancing the information displayed has been, and still is, a major subject for researchers and manufacturers of display technology [1].

### **5.3 The HUD in Common Focusing**

The HUD is basically a development of the conventional Attitude Display Indicator (ADI). Its basic task is to provide both lateral and vertical guidance for approach and flare, lateral guidance for roll out but also other relevant data regarding the flight in progress, such as altitude, speed and navigation information. This information is presented onto a semitransparent glass situated between the windshield of the aircraft and the pilot’s position. The view from the external scene in front of the aircraft passes directly through the semitransparent glass and to the pilot’s eyes. The view observed from the pilot’s seat, looking through the HUD, is thus a combination of the real world outside and the information derived from the HUD [2].

The main purpose of the HUD concept in civil aviation is to increase the pilot’s situational awareness in critical phases of flight, maintaining and even extending the safety margins. This includes conditions where lacks of visual cues are present. Other purposes include offering airlines a cost effective solution in reaching low visibility operations, i.e. approved take offs, approaches and landings in bad weather conditions, access to an increased number of airports when operating in low visibility, recovery from unusual attitudes, increased precision in hand flying, supply of surface guidance information as well as bringing the pilot “back in the loop” in terms of being less a “system monitorer” and more involved in actually flying the aircraft.

## 6 Scanning Techniques

The following chapter serves as an introduction to understanding the human information processing in scanning techniques.

### 6.1 Reduced Dwell Time Equals Increased Situational Awareness

Instruments scanned frequently should be located centrally and close together in space. An example of this theory is Paul Fitz “Basic T” concept, dated back to the 1950’s, which not only created an international standard of primary flight instrument positioning but also improved the scanning techniques remarkably.

Consider the glideslope-indicator on a Primary Flight Display (PFD). When the pilot fixates on the glideslope-cursor of the PFD the time to allow the extraction of information (high-, low- or on the glideslope) from the glideslope cursor to the intention of corrective action is defined as the dwell time. Researchers have found that the human mind has a minimum dwell time of 400-600 milliseconds and this serves as the limitation in human information processing [1]. By reducing the pilot’s need for eye movement when scanning primary flight instruments, the time for extraction of information and action as a response to an evolving situation is reduced. Therefore, reduced dwell time contributes to improved situational awareness.

### 6.2 Serial Processing and Parallel Processing

The pilot of an aircraft in a busy traffic situation must process a wide range of visual information as well as a range of auditory signals. There are two ways of allocating this information that can be identified: a *serial processing mode* and a *parallel processing mode*.

#### 6.2.1 Serial Processing

Different environmental conditions force the pilot to operate in a serial processing mode, also called a “single channel mode”. Most visual tasks require this scanning mode. Moving items, which are to be scanned *apart* in space, contributes to serial processing [1]. An example of serial processing known to pilots is scanning primary flight instruments followed by engine instruments. In this situation the pilot first extracts information from the primary flight instruments, then moves his eyes to the engine instruments to extract information from these.

#### 6.2.2 Parallel Processing

In contrast to the above behavior is the parallel processing mode, also called a “multi channel mode”, in which the pilot maintains a visual awareness of multiple information processed in parallel. Opposite to the serial processing mode, moving items *close together* in space so that they can fall within the field of fovea vision (direct vision) makes it easier to process them in parallel. The assumption that parallel processing is increased as the proximity in space is increased underlies the principle of the HUD. Superimposing the near visual world on top of the far visual world should allow parallel processing of both items of information and reduce the need for eye movements to the instrument panel [1]. In order to achieve parallel processing another factor must be fulfilled, this is the need to focus the HUD presented information to optical infinity.

## 7 Spatial Disorientation and Sensory Illusions

### 7.1 Spatial Disorientation

The brain processes information from the sense organs around the body to determine the position of the body in space. The most important information comes from external, visual cues, which if not present can cause a pilot to become spatially disoriented. Without adequate visual cues, a pilot may become disoriented and lose directional control of the aircraft within 60 seconds from straight and level flight, and even faster during turning maneuvers. The illusions that cause a pilot to become disoriented can be classified as either vestibular or visual [11]. Below follows two examples of visual illusions that may be encountered in flight.

### 7.2 The Black Hole Effect

At night, with no other lighting than the runway lights present there is a lack of visual cues to provide scale. This may result in a false perception of distance and angle leading to an excessively low approach being flown [11].

### 7.3 Shape Constancy and Size Constancy

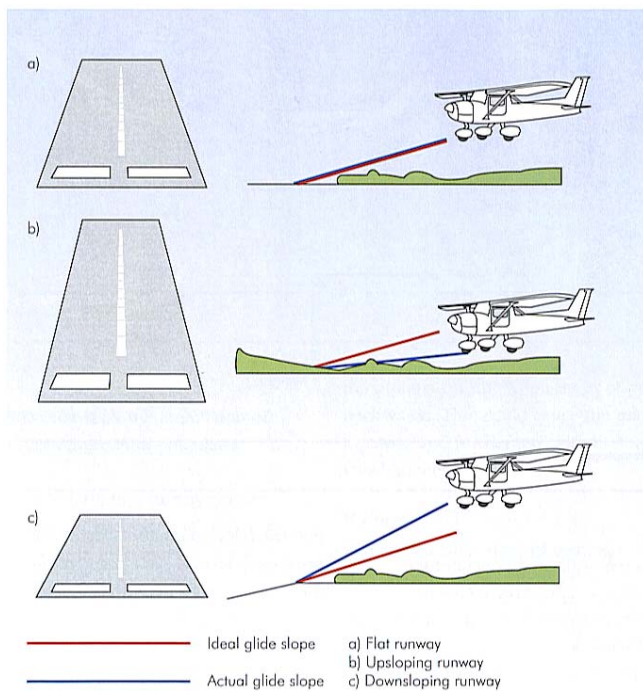

The illustrations present the illusions the pilot has to cope with during final approach and landing. In “a” where the runway is flat, a normal approach is conducted. In “b” where the runway is upsloping, the pilot still tries to achieve the normal aspect and flies a lower approach with the possibility of landing short of the runway. In “c” where the runway is downsloping, the pilot risks being misled into flying a higher approach with the possible result of a long landing and going of the end of the runway [11].

The same reasoning applies with size constancy, where a narrower runway may cause the pilot to fly a lower approach than normal, or the opposite, a wider runway resulting in a higher approach than normal [11].



## 8 Problem Areas Aided by HUD in Approach and Landing

In the following, problem areas in the approach and landing phases of the flight aided by the installation of a HUD system will be discussed. In chapter 12 we will evaluate other phases of flight where the HUD has proved valuable to the pilot's situational awareness.

There are two specific problem areas [2]:

1. The visual approach (with the problem areas described in chapter 7)
2. The transition from Instrument Meteorological Conditions (IMC) to a visual landing.

### 8.1 The Visual Approach

During a visual approach the pilot has to fly a stabilized approach on a safe glidepath, usually 3 degrees of angle. Because of varying and often misleading visual cues the pilot may be deceived into flying on a dangerously low glidepath. Some of the visual cues contributing to this are, as mentioned in chapter 7, the slope of the terrain and lighting conditions in front of and behind the runway [2].

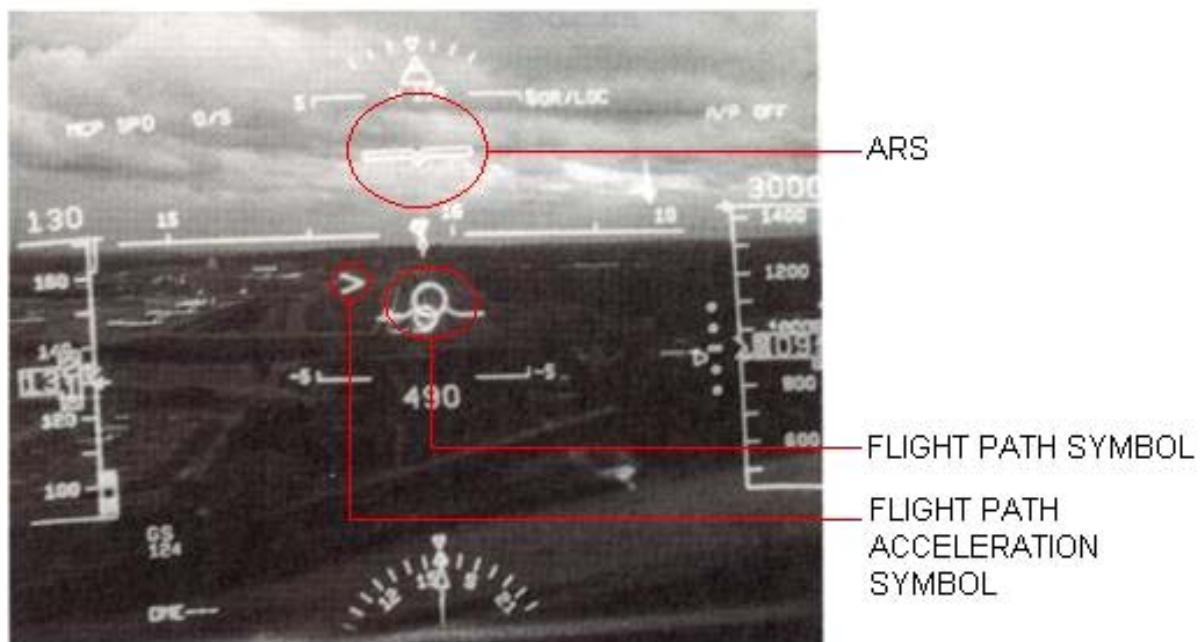

With reference to the illustration above, the flight path symbol indicates where the aircraft is actually *going through space*. With the flight path symbol above the horizon the aircraft is climbing, the symbol below the horizon means the aircraft is descending and without any further control inputs, it will reach the ground at a point indicated. The Aircraft Reference Symbol (ARS) indicates where the aircraft's nose is *actually pointed in space*. The flight path acceleration symbol is an arrowhead moving on a vertical scale on the centre left of the display. It indicates the sum of all forces acting on the aircraft, including thrust, drag and properties of the air mass. When the aircraft is accelerating the symbol lies above the flight path symbol, when decelerating it is below the symbol. To maintain a steady state, the flight path acceleration symbol should be positioned pointing at the flight path symbol [2]. This information, along with the speed tape, allows the pilot to fly the approach without requiring autothrottle [2][4]. It makes the control of speed and flight path angle easier and the possibility of being misled is thus reduced.

## 8.2 The Transition from IMC to Visual Landing

Considering the transition from IMC to visual landing, the problem is not flying the glidepath to flare; it is flying the flare itself [2].

During a conventional instrument approach the pilot flies head down, scanning the instruments, guiding the aircraft down the glidepath. When acquiring visual contact, he must come from head down to head up and complete the landing flare visually.

In adverse weather with a cloud ceiling at minima the time interval between acquired visual contact to touchdown is very short. If any illusions are present the pilot may be misled by these into spatial disorientation.

### 8.2.1 The Klopstein Runway

By placing a contact analog where the real runway will appear the pilot will be able to see an artificial depiction of the runway through the HUD even when flying in IMC conditions. The contact analog is called the “*Klopstein runway*”. It is based on coordinates depicting the perimeters of the runway, originating from the centerline at the glidepath intercept point [2]. Localizer and glidepath information are also presented on the HUD and the pilot can consequently fly the complete approach head up, thus eliminating the transition from head down to head up, reducing the risk of spatial disorientation.

A spin-off effect using HUD in the two problem areas above is an improved precision in hand flying. This was proved by Goteman [3] when researching the width of lateral touchdown footprints\* with and without the use of HUD during final approach.

## 9 A Historical Review

The main motivation for the development of the HUD was to place flight information where the pilot was looking, i.e. out the windshield.

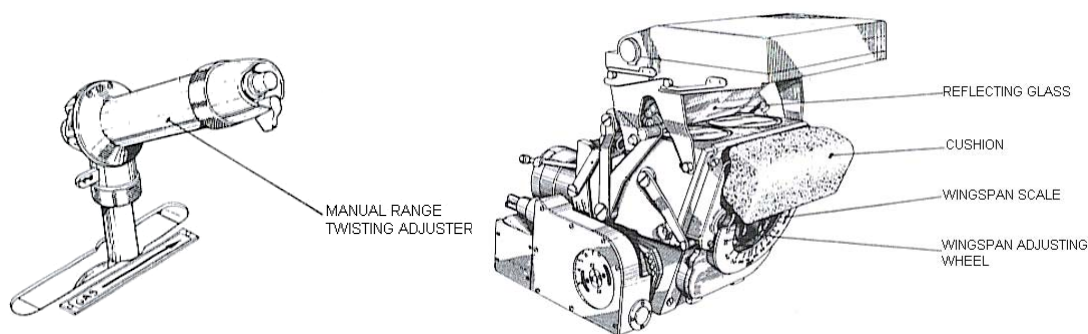

Pictures show the throttle stick and the reflective sight of the SAAB A32 Lansen.

The HUD was first introduced in the late 1950's, based on the reflective gunsight technology from world war two fighters. In these sights the aiming symbol is generated from an electrical source projected onto a reflecting glass [2]. The mounting of the projector was typically on top of the instrument panel in the middle of the pilot's field of view between the windshield and the pilot himself. Using a reflective gunsight in air combat, the pilot had to “calibrate” the sight manually. This was done by input of target wingspan on an adjusting wheel followed by

\* the touchdown footprint is the segment of the runway where the aircraft touches down.

adjustment of the sight to fit as a frame around the engaged target. By doing this, the result was compensation for speed, bullet drops, G-load etc.

In the late 1950's, the reflective gunsight image was projected on to a Cathode Ray Tube (CRT) controlled by computers carried in the aircraft. This marked the birth of the technology behind the modern HUD. The computers were able to automatically compensate the accuracy and adjust the aiming cursor for factors such as range, acceleration forces, bullet drops, target closure, G-load, etc.

The addition of flight data to the aiming symbol, gave the HUD the role of assisting the pilot in landing approaches as well as assisting him in air combat. By the early 1960's HUDs was used extensively in landing approaches providing the pilot with the essential flight data needed without having to look at the instrument panel inside.

The commercial aviation HUD emerged in the early 1980's. The first HUDs were used by Air Inter on their MD-80 aircrafts [4]. They were however solely dependant of the aircrafts FD for guidance and worked merely as a repeater of its information. In 1984, Rockwell Collins Flight Dynamics had developed and certified the first "standalone" HUD for commercial aircraft, called the Head Up Guidance System (HGS) [4]. With the "standalone" system came the opportunity to reduce takeoff- and landing minimums. In 1984 FAA approved CAT IIIA landings with no autoland- or autothrottle system installed provided the aircraft was equipped with a HGS.

## 10 HUD Technology

This chapter will discuss the HUD technology in general. First we will focus on and explain the CRT and the design behind two different types of HUDs. These are the *refractive HUD* and the *reflective HUD*. The first is most commonly found in military aircraft installations while the later is the type most chosen in civil aviation. This will be followed by a description of HUD system architecture. The chapter ends with a brief description of HUD design criteria regarding display clutter.

### 10.1 The Cathode Ray Tube (CRT)

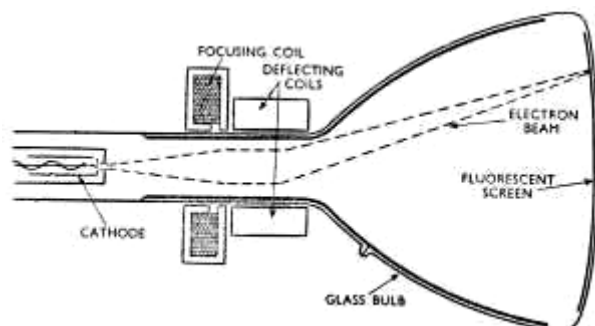

Common for all HUDs is the source of the displayed image, the CRT, which is driven by the symbol generator. The symbol generator sends information to the CRT in form of x- and y-coordinates and it is the CRT's task to depict these coordinates as pixels, i.e. graphics.

CRTs create pixels by generating an electronic ray, which strikes the face of the tube. The face is coated with phosphors making it a fluorescent screen. The phosphors give off light when the electrons hit the surface. Coils near the cathode source in the neck focus the beam. By varying the voltage to a number of deflection plates the resulting beam of electrons may

be directed to a specific point on the tube face and the x- and y-coordinates from the symbol generator may be depicted. The intensity of the beam determines how bright the image will be [2].

### 10.2 Refractive HUD

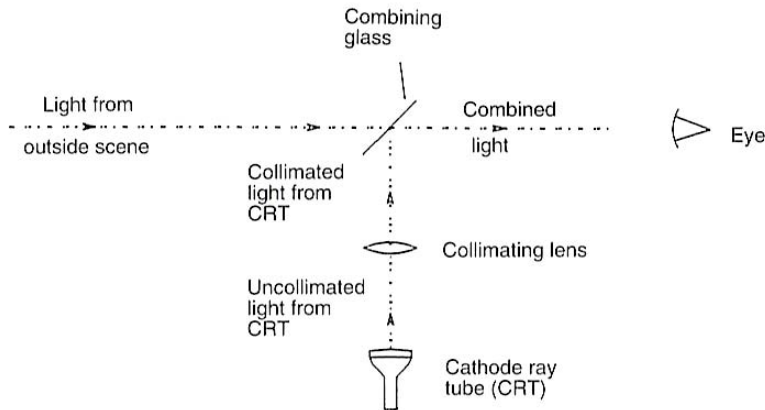

From the CRT the rays are produced in parallel by a collimating lens. The paralleled rays are thereafter projected onto a semitransparent glass (combining glass) and reflected to the pilot's eyes. One advantage of the refractive HUD is the pilot's ability to move his head while still being able to see the displayed image on the combining glass. This is of great use in the environment of air combat where the pilot constantly moves his head in order to stay in contact with his adversary. In order to save room, a folding mirror may be installed between the CRT and the collimating lens. The refractive HUD is controlled via a control panel [2].

### 10.3 Reflective HUD

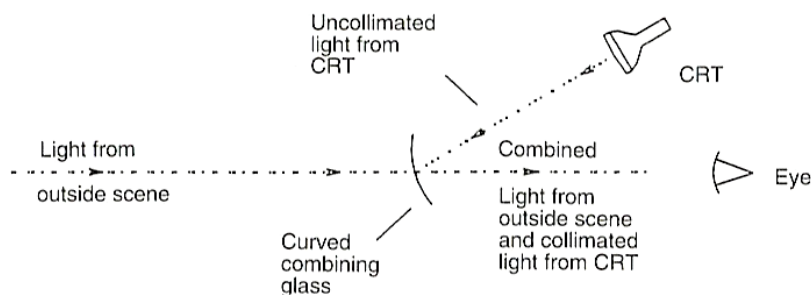

In this design the collimating lens is integrated in a curved, transparent combiner. The technique is based on reflection of the CRT-rays in the combiner. The CRT is situated above the pilot in an Over Head Unit (OHU). The curved combiner is bracket mounted to fold down directly in the pilot's field of view and it displays a 30-degree wide view.

The combiner is in fact an off-axis mirror. An off-axis mirror reflects rays in a direction different than the rays received. The reflected rays are only visible to the pilot within a certain angle. Different from the refractive HUD, this requires him to maintain his head in a fairly fixed position. Fabricating an off-axis optical component usually require grinding a larger surface than is needed. It is also of much importance to shape both surfaces of the combiner so that rays from the external scene aren't distorted in any way [2].

The disadvantage of the reflective HUD is consequently the great level of complexity involved in producing the curved combiner in terms of material and engineering. The great advantage is the capability of enhanced symbol brightness, minimized light attenuation from the external visual scene and the possibility to save room in the cockpit, as the collimating lens is unnecessary [2]. These are the main reasons why the reflective HUD is the most common type in civil aviation industry. The reflective HUD is also controlled via a control panel.

#### 10.4 System Architecture

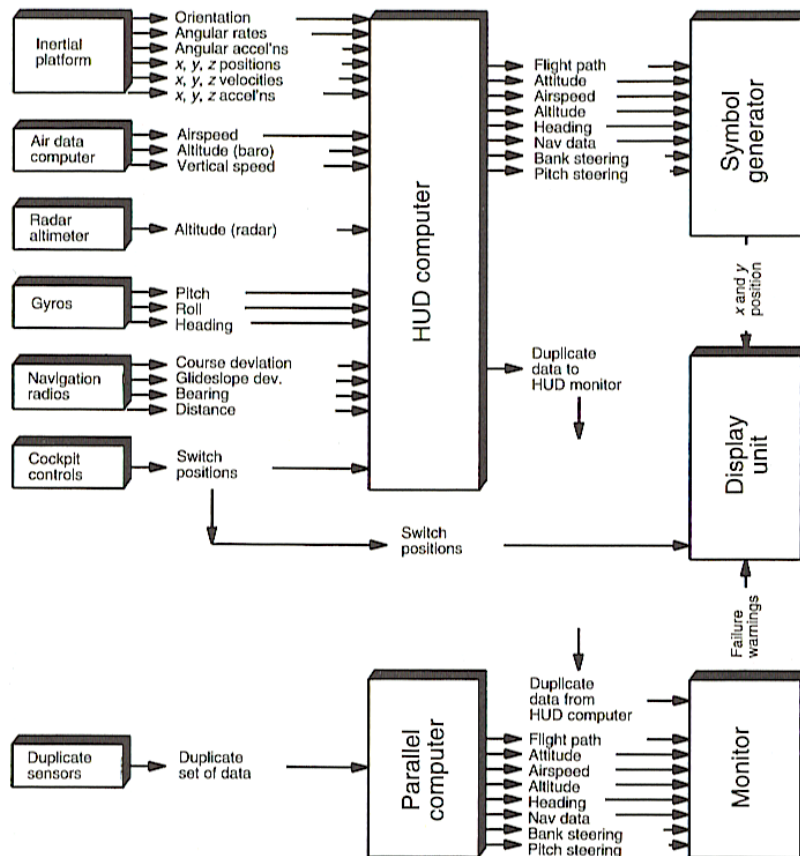

The HUD computer collects information from sources like the Inertial Reference System (IRS), Air Data Computer (ADC), radio altimeter, gyros, navigation radios and cockpit controls. Translated into x- and y coordinates, the HUD computer then provides the information needed for what is to be displayed on the HUD to the symbol generator. Based on this information, the symbol generator generates the necessary coordinates for the graphics, which are then sent to the display unit (CRT) and displayed as graphic symbols on the tube face [2].

Most military HUDs simply pass FD steering cues through to the symbol generator. Civil HUDs compute steering cues in the HUD computer and this makes it a “standalone” system. Civil HUDs are fail-passive and include considerable internal checking of data up to the symbol generator. Any computed discrepancy is designed to prevent the display of false data [2].

All data obtained are in duplicate. One set of data is sent to the HUD computer, the other is sent to the parallel computer. The parallel computer does the exact same thing as the HUD computer but instead of sending the information to the symbol generator it sends it to a monitoring unit. The monitoring unit receives two sets of data, one from the HUD computer and the other from the parallel computer. When discovering divergence between the two sets, a fail warning is sent to the display unit [2].

### **10.5 Display Clutter**

One important concern with HUD symbology is the designer's tendency to include too much of it, generating display clutter. Display clutter is far from exclusive to HUDs but it is particularly critical with see-through displays. Every symbology displayed on a HUD must serve a purpose and lead to improved performance. In fact, not a single pixel may be lit unless it directly leads to improvements. The principle applied for HUD designers is; when in doubt, leave it out [2].

The pilot should have the possibility to reduce the amount of extra, low priority information if it is not desired. It is highly recommended that HUDs have a minimum of 2 levels of declutter [2].

Under some limited circumstances, it may be desirable to automatically declutter the HUD without pilot intervention. Instances where this is practicable include recovery from unusual attitudes and windshear encounters during take off or approach [2].

## **11 The Purpose of the HUD in Civil Aviation**

Why do commercial airlines choose to introduce HUD in their fleets? Today the competition in the airline industry is more demanding than ever. Passenger kilometer costs need constant reductions and on all levels expenses have to be reduced. While reducing the costs airlines of today also have to be more effective in reducing turnaround times and maintaining punctuality in time schedules. Due to bad weather, delays must be minimized. Having to cancel flights, resulting in an airline's complete failure to transport its passengers from A to B by air must be compensated for by providing alternate ground transportations and/or hotel accommodations. This is a very expensive procedure, not wanted by any airline. In the end they will only end up with delayed, unsatisfied passengers and additional costs. Consequently it is in the airline's interest to transport its passengers from A to B on schedule as this keeps the customers satisfied and avoids further expenses.

The main purpose of the HUD concept in civil aviation is to offer airlines a cost effective solution in reaching approved take offs, approaches and landings in bad weather conditions. This includes the purpose of increased situational awareness in conditions where the lacks of visual cues are present. Other purposes includes recovery from unusual attitudes, increased precision in hand flying, supplying surface guidance information as well as bringing the pilot "back in the loop" in terms of being less a "system monitorer" and more involved in actually flying the aircraft. The ability to expand the airlines access to additional airports in bad weather conditions is another factor that motivates the installation of a HUD system. There are some 2400 CAT I, 240 CAT II and only 124 CAT III equipped airports in the U.S. [10]. One of the biggest advantages of the HUD system is the capability to conduct CAT III approaches at CAT II equipped airports and conduct CAT I approaches to lower minimums, thus dramatically increasing the airline's total airport access.

Selling new technology into an airline is difficult. An accountant can be persuaded to buy new airplanes because resale value and mobility limit an airline's losses. But they fear that a new gadget such as a HUD will become as hot an item as an 8-track tape player if it fails to catch on. Any such device must therefore pay for itself in two years at the outside, often much sooner [5]. An airline will be able to recoup the installation cost within 2 years through reductions in weather related flight diversions, cancellations and delays [9].

### **11.1 Southwest Airline's Experience**

When expanding their route-system in 1993, Southwest Airlines included four of the five worst fog cities in the U.S. – Seattle, Portland, Spokane and Sacramento. Fog has the tendency to peak in the early morning and it is at this time Southwest's high revenue business passengers most often choose to fly. These are the passengers that make the airline a living and with the cutting edge competition of today's industry, failing to satisfy their need to fly is everything but profitable. Also, delaying the first launches can have disastrous effects and back up the airline's system all day. Consequently, in order to keep the time schedules Southwest saw no other solution than to develop a low visibility program i.e. CAT II/III operations.

They had two options. To "turn on" the autoland systems already installed on their aircraft fleet, or install a HUD. When investigating they found the recurring costs of the HUD to be much lower than of the autoland system and consequently, Southwest's solution was fitting a HUD system to their entire fleet of 236 Boeing 737-300's, -500's and new on order -700's. Since the HUD has fewer items to be certified and retested compared to an autoland system it provides a cost-effective solution in reaching low visibility approaches [5].

### **11.2 Alaska Airline's Experience**

Alaska Airlines pioneered the commercial HUD concept with its first flight installation in 24 Boeing 727-200 aircraft in 1986. Up until year 1995 Alaska Airlines made 225 landings and 35 takeoffs that could not have been accomplished without the HUD. During this period, 138 captains qualified for CAT III with no pilots unable to qualify. Only one of all CAT III landings were missed due to visibility at decision height giving the HUD a success rate of 99,6 percent [5]. Two thirds of Alaska Airlines financial and operational benefits have come from being able to take off – not land – in low visibility conditions [6]. This fact underlines the effects of not being able to launch an airlines first flights of the day.

## **12 Today's System**

### **12.1 Flight Dynamics Head Up Guidance System (HGS)**

Portland based Flight Dynamics developed and certified the first "standalone" HUD for commercial aircraft use in the early 1980's naming it the Head Up Guidance System (HGS). The HGS was certified by the FAA in 1984 and can today be found in many of the world's premiere airlines including Southwest Airlines, Alaska Airlines and Scandinavian Airlines System [4]. Nearly 1000 Flight Dynamics HGS's have been delivered worldwide, accumulating 5 million hours of airline flight, including 30 000 low visibility operations [7].

The HGS is the only system certified for Low Visibility Take Off (LVTO) with RVR down to 100m [8]. This capability serves as one of the main reasons why airlines already having autoland systems installed on their aircraft should purchase the HGS.

Depending on certification, the HGS computer can provide accuracy for [8]:

- CAT IIIA operations: 50ft DH 200m (600ft) RVR
- Lower CAT I minima: 400m (1200ft) RVR
- LVTO capability: 100m (300ft) RVR

## 12.2 Evaluation of HGS Symbology

Proctor [6] [7], evaluated HGS symbology during different flight phases at two demonstration sessions in a modified flight simulator at Flight Dynamics headquarters, Portland, ORE, 1999 and 2000. The sessions included demonstration of HGS symbology during take off roll, recovery from unusual attitudes and the Surface Guidance System (SGS). To fully appreciate the benefits of the HGS, here follows a summary.

### 12.2.1 HGS During Take Off Roll and Take Off

During the take off roll the HGS provides the pilot with command guidance to track the runway centerline and digital countdown of runway remaining. The HGS also comprises aids in handling Rejected Take Offs (RTO), engine failures and tailstrike protection [6].

When initiating a RTO a decelerating rate index appears in the middle of the HGS display. As brake pressure is increased, the index pointer translates vertically downward past marks labeled after autobrake settings. This allows a more effective manual brake modulation both during normal and emergency braking and also a more effective monitoring of autobrake performance, if selected [6].

Suffering an engine failure, small boxes appear under the flightpath symbol. The boxes move laterally and function similarly to a turn and bank ball indicator. The pilot simply has to “step on the ball” in order to correct the flightpath for the asymmetric thrust and drag experienced [6].

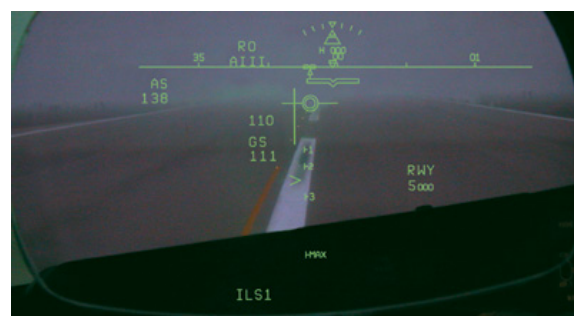

Tailstrike protection is generated through a pitch limit symbol that first appears on the top of the pitch scale and then translates downwards. Tailstrike protection can be used with or without the FD activated during take off. Upon landing the pitch limit symbol is replaced with a large letter “TAILSTRIKE” warning across the center of the display. The need for tailstrike protection is becoming more and more important as aircraft body length extends [6].



### 12.2.2 HGS Aid in Recovery from Unusual Attitudes

Recovery from unusual attitudes caused by aircraft upset or pilot spatial disorientation is aided by the use of the HGS. By increasing the pilot's situational awareness he stands a considerably better chance of recovering. The aim is to provide an instant alert and change the pilot's priorities to getting the aircraft back in control.

The HGS symbology that helps pilots recover more quickly from unusual attitudes and flight upsets have been developed by practicing a "keep-it-simple" philosophy [6].

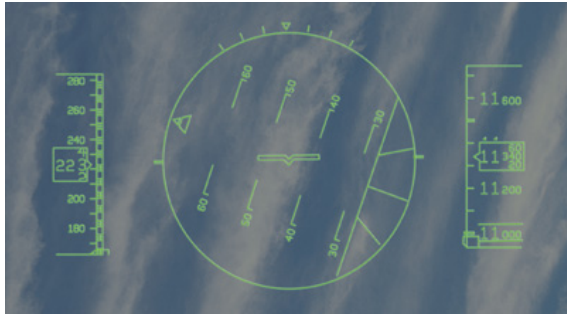

When entering an unusual attitude, automatic decluttering of the HGS increases the situational awareness of the pilot and a simplified symbology format is displayed. This is triggered when the bank angle exceeds 55 degrees and/or the pitch angle exceeds 35 degrees nose up or 20 degrees nose down [6].

Displayed on the HGS is a large attitude sphere, in it an aircraft attitude reference symbol and three perspective lines combined with a horizon line to indicate the relative position of the ground to the aircraft. Additional information around the edges of the display comprises of high- and low speed "barber pole" warnings as well as trend vectors on both the speed and altitude tapes [6].

System software returns to normal HGS symbology after the aircraft has flown for 5 seconds within an envelope consisting of 10 degrees or less bank angle and from 10 degrees positive- to 5 degrees negative pitch angle [6].

### 12.2.3 Surface Guidance System (SGS) and Symbology

Runway incursions are a major safety concern and are increasing strongly as traffic continues to grow [7]. Throughout history many accidents can be related to runway incursions, among them the fatal collision between the SAS flight SK686 and a German Cessna Citation II business jet at the Linate Airport, Milan, Italy on the 8th of October 2001. SGS can help address the 60 percent of runway incursions that are the result of pilot deviations, as well as many of the 15 percent that are the result of controller errors.

The main intent of the SGS is to increase the pilot's confidence level. A pilot normally taxi only at a speed he feels comfortable with. Consequently, he taxies slower when in reduced visibility conditions or when unfamiliar with the airport and its surroundings. The SGS boosts the pilot's situational awareness resulting in increased safety and capacity at busy airports, especially during night and low visibility conditions [7].

The SGS is a software and symbology upgrade to aircraft fleets already having the HGS installed. It integrates with the aircrafts existing HGS, FMS and navigation database to provide head up display standardized ground routes between the terminal and the runway. Once implemented, SGS should help automate airport ground control, an out of date system that now relies on paper charts and voice messages [7].

The SGS dataset is activated a few seconds after touchdown. It uses large hollow cone shaped triangles to indicate runway- and taxiway edges. Smaller triangles indicate runway and taxiway centerlines. A diamond shaped guidance cue, superimposed on the runway surface directly in front of the aircraft provides steering information with corrections similar to the “step on the ball” instructions pilots receive in basic flight training. Text and digital callouts around the edges of the HGS display presents current and target speeds as well as heading information [7].

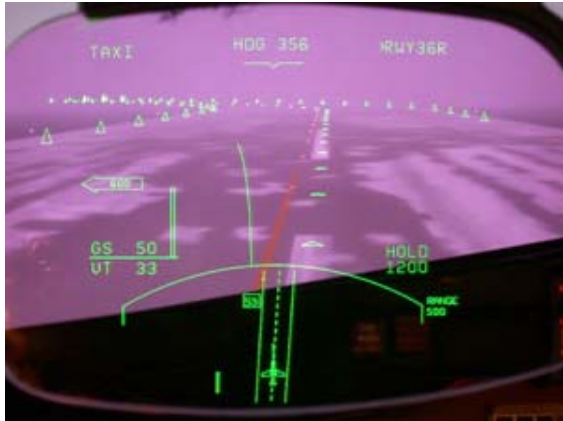

A vertical line in the center of the display serves as a turn trend vector. When not taxiing on the centerline a divergence in the turn trend vector is recognized and the diamond shaped guidance cue is deflected in order to provide the pilot with corrective action information. To the lower left of the display an arrow indicates upcoming turns and in it is a digital distance counter readout displaying distance to go until the turning point [7].

In the future, data link transmissions of clearances between the controller and the flight crew will be displayed as a pop up text indicating ATC clearance limit. When reaching the clearance limit a line of solid green cones appears to form a physical barrier across the runway. If crossing this limit, text warnings appear saying “STOP IMMEDIATELY”. Following the data link receipt of further clearance, the text “CLEARED TO PROCEED” is displayed and the barrier of cones is extinguished. A system capable of Controller to Pilot Data Link Communications (CPDLC) could be certified before 2006 [7].

NASA simulation and operational tests have shown a 21 percent increase in taxi speeds when pilots have a moving map and head up guidance for ground reference. Reduced runway times benefit all aircrafts in the queue to take off or land and the SGS can save one minute per aircraft on the runway at big hubs [7].

Flight Dynamics have adapted to the NASA research and in the SGS concept, the Left Pilot (LP) navigates via the HGS and the Right Pilot (RP) follows the progress of the aircraft via bird’s eye view moving map of the airport on a head down display [7].

### **13 The Possibility of Future CAT IIIB Certification**

Researchers are exploring the possibilities of certifying CAT IIIB operations with current HUD systems. Here follows a brief summary of the theories driven.

### **13.1 The “Hybrid” CAT IIIB**

Current CAT IIIB autoland systems are fail operational, triplex channel systems. In these systems, failure of a single channel in the autopilot allows the system to still function normally and the approach may be continued [2].

Current CAT IIIA autoland systems are fail passive, duplex channel systems. This means upon failure of one autopilot channel the system disconnects and requires the pilot to take over the controls [2].

In combining two fail passive autoland systems an airline can achieve the same reliability as in a CAT IIIB autoland system [2].

Known as a “Hybrid” CAT IIIB or “Super fail passive” system, the concept is based on the combination of a CAT IIIA autoland system with a CAT IIIA HGS (also fail passive) to achieve CAT IIIB [4].

In a CAT IIIA HGS approach the localizer and glideslope of the ILS is displayed on the HGS and the pilot simply flies the ILS heads up. Using the HGS, the pilot monitors the progress of the autoland system and uses the HGS as a landing aid if there is improper autoland performance. This type of system approach provides the airline with a cost-effective solution since a HGS usually is much less expensive, both in installation and recurring costs, than a third autopilot channel [5].

## 14 Conclusion

The main conclusion is that the HUD aids the instrument scanning process in phases of flight with high workload, such as take off, approach and landing resulting in increased situational awareness, flight precision and flight safety. The HUD also serves as a valuable tool in other phases of flight, such as recovery from unusual attitudes, surface guidance etc. When conducting HUD approaches the system also acts as a “pilot motivator”, putting the pilot back behind the controls, being less a “system monitorer”.

Head up flying increases precision and flight safety in two distinct ways:

- It obviates the need for pilots to transit back and forth between the instrument panel and the outside view in a late stage of an approach.
- It presents the information needed to fly the aircraft and presents it in a way that allows the pilot to extract the information in a parallel processing mode. This leads to increased situational awareness.

In analyzing statistics, flight crew errors are the primary cause of aircraft accidents and the most specific cause is loss of directional control during intermediate and final approach. The need to increase the pilot’s situational awareness in these phases of flight was the main purpose with the development and introduction of the HUD concept into the civil aviation industry.

Another reason for the introduction was the airline’s will to maintain traffic regularity. This is done by keeping delays, cancellations and diversions to a minimum. A factor contributing to traffic irregularity is bad weather situations. The HUD provides a cost effective solution in reaching low visibility operations and the best solution to approved LVTO’s. Consequently, installation of a HUD system improves regularity. An airline can recoup the \$250.000/per aircraft investment in their HGS system within about two years through reductions in weather related flight cancellations and delays [9].

When comparing the maintenance cost per flight hour between the HUD system and an autoland system the HUD system is *seven times* less expensive than an autoland system [4]. This fact underlines the cost effectiveness in a HUD system.

Considering airlines with an autoland system already activated on their aircrafts, the HUD system provides LVTO capability. It also enables the flight crew to monitor the autoland progress heads up.

There are some 2400 CAT I, 240 CAT II and only 124 CAT III equipped airports in the U.S. [10]. One of the biggest advantages of the HUD system is the capability to conduct CAT III approaches at CAT II equipped airports and CAT I approaches to lower minimums, consequently dramatically increasing the airline’s total airport access. These facts serve as the main motivation for HUD installation in already autoland equipped fleets.

With the introduction of the HUD system in the civil aviation industry, a further step is taken to improve accident statistics.

## 15 References

- [1] Stokes, Alan & Wickens, Christopher & Kite, Kirsten, 1990, *Display Technology Human Factors Concepts*, ISBN 0-89883-530-5
- [2] Newman, Richard L, 1995, *Head Up Displays: Designing the Way Ahead*, ISBN 0-291-39811-1
- [3] Goteman, Örjan & Smith, Kip & Dekker, Sidney, Linköping Institute of Technology, Sweden, 2004, *HUD Use Improves Landing Performance in a Full-Motion Simulator*
- [4] Hartman, Brian K & Moylan, Phil, Flight Dynamics, Portland, Oregon, 1994, *Head Up Guidance Systems: The Foundation of Situational Awareness Systems*
- [5] Sweetman, Bill, Air Transport World, 1995, *Out of the Fog*
- [6] Proctor, Paul, Aviation Week & Space Technology, New York, 1999, *Enhanced Head-Up Symbology Builds Situational Awareness*
- [7] Proctor, Paul, Aviation Week & Space Technology, New York, 2000, *New Head-Up Tool Aims to Cut Runway Incidents*
- [8] Flight Dynamics homepage, <http://www.flightdynamics.com>
- [9] McKenna, James T, Aviation Week & Space Technology, New York, 1999, *Carriers Seek Greater HUD Availability; Sold on the safety and operational benefits, HUD users want the systems for most of their transports*
- [10] Sutton, Oliver, Interavia Business & Technology, section Air Transport & General Aviation, 2000, *Airlines Getting hooked on VGS*
- [11] London Metropolitan University & Nordan AS, 2003, *Human Performance & Limitations*, ISBN 82-8107-005-6