



LUND
UNIVERSITY



BOLT FIXINGS IN TOUGHENED GLASS

CAMILLA BENGTH

Structural
Mechanics

Master's Dissertation

Department of Construction Sciences
Structural Mechanics

ISRN LUTVDG/TVSM--05/5136--SE (1-53)
ISSN 0281-6679

BOLT FIXINGS IN TOUGHENED GLASS

Master's Dissertation by
CAMILLA BENGTH

Supervisors:

Kent Persson, PhD,
Div. of Structural Mechanics

Lars Bengtsson,
Fasadglas AB

Copyright © 2005 by Structural Mechanics, LTH, Sweden.
Printed by KFS I Lund AB, Lund, Sweden, June, 2005.

For information, address:
Division of Structural Mechanics, LTH, Lund University, Box 118, SE-221 00 Lund, Sweden.
Homepage: <http://www.byggmek.lth.se>

Abstract

Title: Bolt fixings in toughened glass

Author: Camilla Bength

Supervisor: Kent Persson, Ph.D. Division of Structural Mechanics, LTH

Research needs: Glass has been used for a long time, mostly in the window and packaging industry, but lately architects and design engineers have become more and more interested in glass as a load-bearing (building) material. It has become a challenge to use less other materials in the glass-structures or at least not to let it show too much. One area of big interest is bolt fixings. Design engineers are now interested in getting a design tool concerning bolt fixed glass that makes it easy to decide distances both between the holes and from the hole to the edge.

Objectives: The purpose with this master's thesis is to investigate and bring forth possible relations between the strength and the design parameters regarding holes in glass/bolt fixed glass. Later these relations may be used to establish a simple design tool.

Method: To identify the loads working on the glass fixing a simple finite element modelling of a glass balustrade was done with a line-load placed at right angles to the upper edge. The result from this helped to come up with a suitable way to perform practical tests to decide the strength of the glass around the hole. The practical tests were also analysed in detail with the finite element method-based (FEM-based) program ABAQUS to be able to compare the calculations with the real tests and in that way confirm any given relations so that the program can be used to simulate the reality and give analytical connections.

Conclusions: Glass is a strong material and can take far higher tensile stresses than most design data is indicating, but that concerns glass exposed only to pressure or tensile stress. Glass exposed to bending leads to a moment at the fixing too big for the glass with only one bolt to handle. To receive a better statistical basis to establish a trustable design tool, more sets of testing has to be performed. Glass has numerous defects very difficult for the human eye to detect, why further testing is quite important for the determination of the strength. The finite element analyses (FE-analyses) for the compression test corresponds pretty well to the experimental test, whereas the bending test analysis should be calibrated more accurately if it is going to be used as a tool of comparison between different parameters.

Keywords: Toughened laminated float glass, tensile strength, Young's Modulus, bolt fixings, FEM, ABAQUS,

Sammanfattning

Titel: Bultinfästning i härdat glas

Författare: Camilla Bength

Handledare: Kent Persson, Institutionen för Byggnadsmekanik, LTH

Problemställning: Glas har använts sedan länge, framförallt i fönster- och paketeringsindustrin, men på senare tid har arkitekter och konstruktörer blivit mer och mer intresserade av att använda glas som bärande delar och att i glaskonstruktionerna använda så lite annat material som möjligt. Ett område som är högintressant är infästningar av glas eftersom det är just här man ofta måste blanda in andra material. Konstruktörer är nu intresserade av att få ett dimensioneringsunderlag för bultade glas, där avstånd mellan infästningspunkter/hål samt kantavstånd ska kunna bestämmas.

Syfte: Syftet med examensarbetet är att försöka få fram eventuella samband mellan hållfasthet och designparametrar gällande glas med hål/bultade glas. Dessa samband kan sedan om möjligt användas för att etablera ett enkelt dimensioneringsverktyg.

Metod: För att identifiera de laster som verkar på glaset runt hålet gjordes en finit elementmodellering av ett glasträcke med en dimensionerande linjelast, enligt Boverkets konstruktionsregler, som verkar vinkelrätt mot överkantens längdriktning. Resultaten användes sedan för att ta fram en lämplig provningsmetod för att bestämma hållfasthet i förbandet. Provningsmetoden analyserades även så detaljerat som möjligt i det finita elementmetodbaserade (FEM-baserade) programmet ABAQUS för att jämförelse med de verkliga proverna ska ge möjlighet att bekräfta eventuella samband och på så sätt få fram ett sätt att kunna simulera verkligheten.

Slutsatser: Glas är ett starkt material och kan klara mycket högre belastning än vad de flesta designvärden visar, men det gäller bara när glas är utsatt för endast tryck- eller dragspänningar. När glas utsätts för böjning uppkommer ett moment vid infästningen som är för hög för glas med bara en bult att klara av. För att få fram bättre statistisk grund för att kunna etablera ett trovärdigt dimensioneringsverktyg, måste fler testomgångar utföras. Glas har ett flertal defekter som är väldigt svåra för det mänskliga ögat att upptäcka, varför ytterligare tester är viktigt för bestämning av hållfastheten. Finita elementanalyserna (FE-analyserna) för tryckprovningarna överensstämde relativt bra med provningarna medan böjprovanalyserna bör kalibreras noggrannare om de ska kunna användas som ett verktyg för jämförelse mellan olika parametrar.

Nyckelord: Härdat laminerat flytglas, draghållfasthet, elasticitetsmodul, bultförband, FEM, ABAQUS.

Acknowledgement

This master's thesis was performed at the Division of Structural Mechanics, LTH, Lund University, Sweden, in cooperation with Fasadglas Bäcklin AB during the spring of 2005. Physically the work was done at SWECO BLOCO AB, Stockholm, Sweden, with the exception for the experimental tests, which were performed at LTH, Lund.

I've been studying Civil Engineering at LTH focusing on structural engineering, building construction and structural mechanics (mostly FEM) and the summer of 2004 I was given the chance to get some work experience at SWECO BLOCO AB, a consulting company within structural engineering. While I was there I saw how the use of glass as a load-bearing building material was growing in a great extent and thanks to the collaboration between BLOCO and Fasadglas I got to, with proposition from Per Ancker (BLOCO), do my thesis for Fasadglas.

I want to give my supervisor, Kent Persson Ph.D. at the Division of Structural Mechanics, big thanks for his guidance and patience. His competence and calming effect helped me manage a big challenge. I also want to express my gratitude to Lars Bengtsson, Fasadglas, who defined the objectives for this thesis and been a great help providing information from his international contacts (John Colvin among others). A special thanks to the staff at the Division of Structural Mechanics, Thord Lundgren, Technician and Kent Persson, Ph.D. for helping me during the experimental tests performed at the Division of Structural Mechanics.

Last but certainly not least I want to express my appreciation to Sören Hed and the personnel at BLOCO for taking good care of me at the Division of Building Engineering.

Symbols

ε	Strain
ν	Poisson's ratio
σ	Stress
c	Length of the Griffith flaw
E	Young's modulus
F	Force
F_{\max}	Maximum force
F_{mean}	Mean force
G	Shear modulus
k	constant
L	Original length
ΔL	Change in length
M	Moment
S_{\max}	Maximum (Ultimate) stress
S_{mean}	Mean stress
U_{\max}	Maximum displacement
U_{mean}	Mean displacement
Y	Tension on the surface at room temperature

Contents

1	Introduction	11
1.1	Background	11
1.2	Research needs	11
1.3	Objectives and limitations	11
1.4	Outline of the work.....	12
2	Materials	13
2.1	General remarks	13
2.2	Glass balustrades and bolt fixings	13
2.2.1	Bolts	14
2.3	Toughened laminated float glass	14
2.3.1	Annealed glass.....	15
2.3.2	Toughened glass	15
2.3.3	Laminated glass.....	16
2.4	Physical and Mechanical properties of glass.....	16
2.5	Holes in glass.....	17
2.5.1	Norms and rules/Standards.....	17
2.5.2	Effects.....	18
2.6	Properties of PVB, EPDM and nylon.....	18
3	Experimental determination of strength in bolt fixings in toughened glass.....	21
3.1	Background	21
3.2	Compression test	21
3.2.1	Purpose	21
3.2.2	Specimens for testing	21
3.2.3	Tools and preparations	23
3.2.4	Experimental test.....	26
3.2.5	Results	28
3.2.6	Discussion	32
3.3	Bending test.....	33
3.3.1	Purpose	33
3.3.2	Specimens for testing	33
3.3.3	Tools and preparations	34
3.3.4	Experimental test.....	35
3.3.5	Results	36
3.3.6	Discussion	38
4	FE-modelling of the experimental methods	39
4.1	FE-method.....	39
4.1.1	ABAQUS.....	39
4.2	Purpose	39
4.3	Prerequisites	39
4.4	Compression test	40
4.4.1	Geometry	40
4.4.2	Materials.....	40
4.4.3	Modelling	40
4.4.4	Loads and boundary conditions.....	41

Bolt fixings in toughened glass

4.4.5	Results	41
4.5	Bending test.....	48
4.5.1	Geometry.....	48
4.5.2	Materials.....	48
4.5.3	Modelling	48
4.5.4	Results	50
4.6	Discussion	53
5	Evaluation of the results from the analysis	55
6	Future work	57
	References	59

1 Introduction

1.1 Background

Lately architects and clients have gotten interested in using bolt fixings for glass balustrades, either for cylindrical or countersunk holes. The objectives are to affix the glass as invisible as possible onto the building structure where the glass will carry its own weight and existing loads. The Swedish standards prescribe the use of laminated and toughened glass to prevent people from injuries. The rubbery foil in laminated toughened glass makes the glass stay put even if it breaks; in opposite to the use of a simple toughened glass that leaves an open hole at failure. Fasadglas AB has in previous collaboration with students doing their master's thesis, performed tests of strength in laminated glass and done finite element analyses (FE-analyses) of glass balustrades. Some of the results from these papers may serve as a basis for this work.

1.2 Research needs

Bolt fixings, where glass preferably should stand alone without any frames, are rather new on the market and that is why investigations are needed. It has come to the point where individual companies are performing physical tests and surveys, among other things for safety reasons.

Holes in glass lead to stress concentrations. To make the effect of the stress concentrations less dangerous, the glass should be fully analysed for the effect on the applied forces to ensure this is acceptable. [14]

Analysis of the stresses, by using formulae with stress concentration factors, FE-analysis and physical testing with strain gauges, makes it possible to accurately determine the stress around the holes. The value will depend on confidence in the accuracy of the stress analysis and on the quality of the toughened glass. [14]

1.3 Objectives and limitations

The objectives with this report are to provide design strength data of bolt fixed toughened glass to enable better calculations for the determination of such parameters as distances between holes, distance from a hole to an edge or appropriate sizes based on the particular load. The strength data is determined through physical testing and FE-analysis.

The final goal is to use the results as a crib in form of a tablet or even better a simple computer program. Moreover, if a FE-model, able to simulate the results from the physical testing, is developed, a numerical tool for analysis of bolt-glass joints has been made available.

To restrict the work, two types of stainless steel bolts from the market were studied. The bolts with their design including the gaskets are the basis for the testing. The type

of glass being used is toughened laminated float glass with an intermediate layer of a plastic material, polyvinyl butyral (PVB). The choice of thickness of the glass is based on experience, tips from experts and not to get too many sets of testing.

1.4 Outline of the work

To be able to identify the loads acting on the glass in a bolt fixed glass balustrade, an initial analysis using the finite element method-based (FEM-based) program ABAQUS was first made. The analysis was primarily based on data taken from the thesis written by A. Månsson [9]. Some of the data was also taken from the work of C. Carrick and J. Vasur about strength of laminated glass [5]. The results from the first modelling were used for designing a suitable test set-up for experimental testing of glass with the aim of determining its strength around the hole. Practical testing was then done with the developed method and geometry, which also was analysed in detail using ABAQUS. The analysis was evaluated on the basis of the results from the experimental testing.

2 Materials

2.1 General remarks

In this chapter, a brief introduction of the materials and their properties of interest for this work are presented. For more information about glass as a material, the manufacturing process etc. refers to the books written on the subject such as “Glass in building” [3], “Glass for buildings – is it crystal-clear?” [8], “Glass in structures” [10] or the book from the Swedish company Pilkington Floatglas AB “Glasfakta 2004” [12].

The parameters [12] needed to be taken into consideration for decision making on glass for designing purpose is for instance the thickness of the glass, width, height, type (float glass, toughened, laminated etc.) and the load on the glass. The outer parameters ruling the sizes of glass at the production of glass balustrades are the height according to standards and desires of the architects. It is also important to know what is possible to actually manage and produce at the manufacturing.

2.2 Glass balustrades and bolt fixings

The most common way to support glass in frames is four-edge glazing. It can also be done with three- or two-edge glazing [3]. To face up to the trend of frameless glazing, glass can be fixed with discrete clips or by using bolt fixings and metal spreader plates to clamp the glass. In this thesis the fixing of the balustrade is going to be made directly onto the joists where the glass will bear its own weight and existing loads without any frames. According to Pilkington a railing on top of the glass pane is recommended as an extra safety when using this kind of fixing [12]. When using bolt fixings near the corners of the pane the glass around the hole will be subjected to large loads, and stress concentrations in that area are a fact. The spreader plates will move the stress away from the hole to around the edge of the clamping plate. This reduces the stress concentration factor [14]. Fixings for clamping should be used when there is a risk for the glass to be bent across the fixings. This can for instance happen when the bolt fixings are in the wrong position. According to Swedish standards (BKR), a railing should cope with a characteristic line-load of 800 N/m (Table 2-1).

Table 2-1 Characteristic line-load against a railing [2]

Characteristic imposed load, uniformly distributed in free action [kN/m ²]	Characteristic line-load against a railing [kN/m]
$q_k \leq 2.0$	0.4
$q_k \geq 2.0$	0.8 3 ¹

¹ If breakage of a railing for a grandstand, or such, can result in a large number of people falling down. (BFS 1998:39)

2.2.1 Bolts

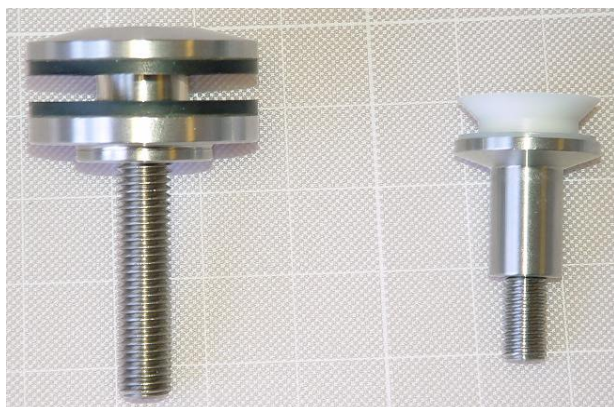

Figure 2-1 Bolts used for the fixings, for cylindrical holes to the left and for countersunk holes to the right

Two types of M10 bolts are here used as fixings, one for glass with cylindrical holes and another for glass with countersunk holes (as shown in Figure 2-1). The diameter of the cylindrical hole is about 28 mm. The bolt in this case has a cylindrical metal piece (spreader plate) screwed onto an inner metal piece with a rubber gasket (EPDM) in between the metal and the glass. These have an outer diameter of 50 mm. The other type for the countersunk hole conceals the bolt as much as possible. Here the hole has an outer diameter of 32 mm and an inner diameter of 22 mm. The gasket between the metal and the glass consists of plastic material (nylon).

2.3 Toughened laminated float glass

To accomplish the best possible safety for glass balustrades high above ground level in Sweden it is recommended to use toughened laminated float glass. Glass subjected to loads at normal temperatures leads to elastic deformation and when the maximum limit is reached, the toughened glass breaks without plastic deformation. This explains the fact that glass can sustain a larger uniformly distributed load than a concentrated load and more than double the load for short term than for long term [3]. When the toughened glass breaks, it ends up in thousands harmless little pieces, and the intermediate plastic foil in between the glasses in a laminate helps the little pieces to stay put, thus reducing the risk of injuries. The illustration in Figure 2-2 shows the characteristics of broken glass.

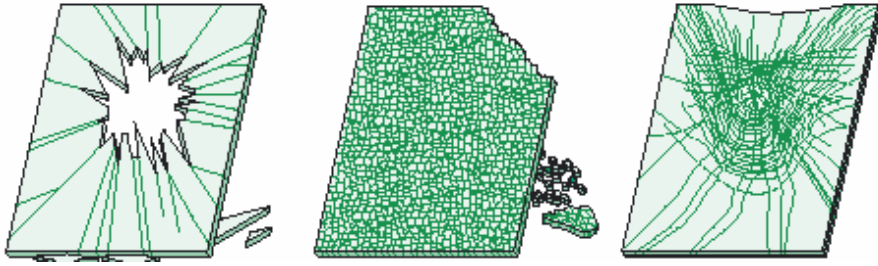

Figure 2-2 Fracture characteristics of, from left to right, annealed, toughened and laminated glass [12]

2.3.1 Annealed glass

Annealed (“ordinary”) glass is the end product of the float glass process. It is carefully cooled through the range of temperatures where the glass solidifies so that no residual stresses develop. Float glass is made using a bath of molten tin, where molten glass is floated along the surface. The perfectly flat surface of the tin is transferred to the glass [8].

2.3.2 Toughened glass

Toughened glass is annealed glass that is heated to the temperature of its softening point (650°C) and then rapidly the surfaces are chilled by air jets. The central region cools slower, which will put the surface layers into a compressive state while the central region is being put into tension. If the cooling process is not done in a controlled manner the inner tensions ends up way too high which reduces the strength and may cause fracture initiations. When the glass is toughened, the bending strength increases by a factor of 4 or 5 and the compressive strength increases so that it is able to resist tensile stresses at its edges. In Figure 2-3 the stress profiles in annealed and toughened glass are shown [14]. The glass is now also less sensitive to rapid variations of the temperature. It can not endure as many scratches on the surface as ordinary glass and the deflection is the same at the same load. The big advantage with the toughened glass is the small harmless pieces at fracture [4]. In this work, only toughened glass is considered.

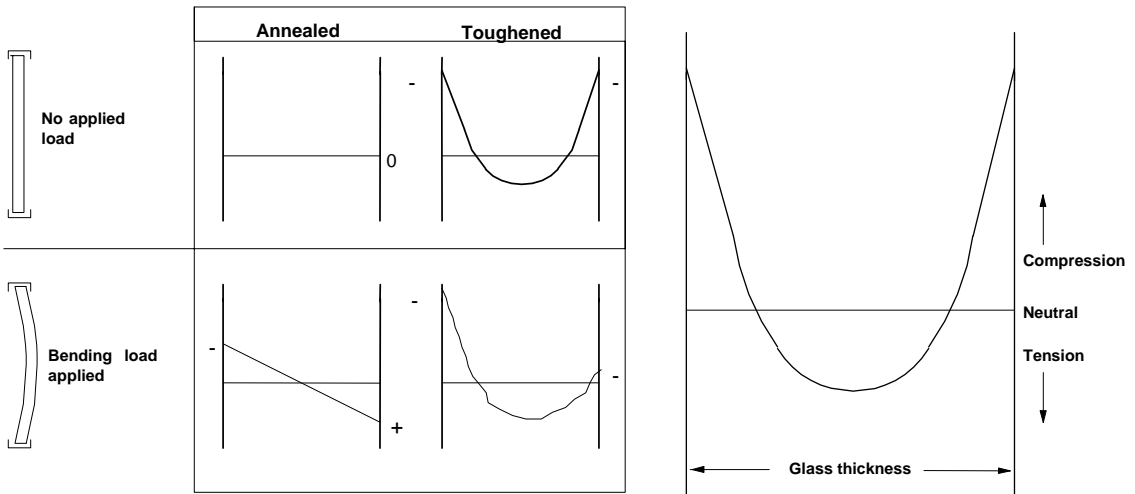

Figure 2-3 Stress profiles in annealed and toughened glass [14]

Toughened glass can break for many reasons, for instance glass-to-metal contact causing damage to the compressive layer of the glass. Glass also contains inclusions, mostly invisible for practical purposes. Nickel sulphide (NiS) is one of them, which is going through a change in the crystalline structure (a phase change) at 380°C that also results in a volume change. Cooling the glass too rapidly means that the NiS does not have time to go back into its original volume and remains unstable inside the glass. It may keep growing and in the end start a micro fissure that eventually leads to fracture of the pane. One factor affecting breakage due to NiS is the toughening quality, the higher the built-in stress, the smaller the size of inclusion is needed to initiate fracture [8].

2.3.3 Laminated glass

Laminated glass is made by gluing two or more glass panes together with an intermediate layer of PVB. They are pressed together during heat supply and the plastic foil softens so that it sticks together with the glass and thereafter the glass is put under pressure so that all the air is pressed out. Due to the same index of refraction for the glass and the PVB, the glass maintains its transparency. If the laminated glass is made from “ordinary” float glass, it is still workable (cutting and drilling is possible) and the PVB helps the fractured glass to stay put inside the construction. [4]

2.4 Physical and Mechanical properties of glass

Glass is a linear elastic and isotropic material with no plastic behaviour at normal temperatures, which can explain its brittle fracture. It follows Hooke’s law ($\sigma = E \cdot \epsilon$) and for isotropic materials the relation between Young’s modulus, E , and the shear modulus, G , can be written:

$$G = \frac{E}{2(1+\nu)} \quad [\text{GPa}]$$

G = shear modulus [GPa]

E = Young's Modulus [GPa]

ν = Poisson's ratio

Young's modulus for glass vary in the literature between 70 and 75 GPa [3] and the results from Carrick and Vasur give a value of 78 GPa [5]. This figure was consequently used in this thesis. The mechanical properties of interest are listed in table 2-1.

Glass breaks under tension. In spite of pure pressure supply, tension is always there since the glass specimen is expanding sideways (Poisson's ratio). The strength of glass is in reality less than 1% of the theoretically calculated strength. It is hard to give a precise value for the true compressive strength but 1000 MPa is often mentioned and the theoretical strength lies much higher with 21000 MPa. In theory float glass has a tensile strength between 6000-9000 MPa while the true tensile strength from testing ends up around 30-100 MPa. This can according to A. A. Griffith be explained by a large amount of micro defects [1], so called Griffith flaws. The amount of defects varies from glass to glass. The defects are created at the manufacturing and keep creating during the use of the glass. When the glass is subjected to tensile stress the inner tensions in the flaws can lead to fracture initiation. According to Griffith's theory, the true tensile strength can be written:

$$\sigma_{true} = k \sqrt{\frac{EY}{c}} \quad [\text{MPa}]$$

k = 0.81-1.27 depending on the chosen geometry of the flaw

Y = tension on the surface at room temperature [MN/m]

c = length of the flaw

The cut surface is also filled with defects/fracture initiations, where the size and the amount vary with the quality of the cutting [12].

Pilkington is using the design strength of 50 MPa for short term load application and Colvin has the same parameter set to 59 MPa. For these figures a safety factor is applied.

2.5 Holes in glass

2.5.1 Norms and rules/Standards

Holes in glass are made using a diamond drill, since this is the only type hard enough to cut through glass [14]. Holes can not be made in toughened glass; it has to be done in the float glass before the hardening process. The reason for this is that the internal tensions and the compressive stresses are released and the glass breaks due to the unbalance between the pressure and tensile zones. Figure 2-4 shows sketches of the

relations between diameters, thickness of the glass and distance hole/edge according to the Swedish company Emmaboda Glas AB [7]. These recommendations are only a practical limitation for the hardening process and they have nothing to do with the best location for the holes considering best possible load bearing.

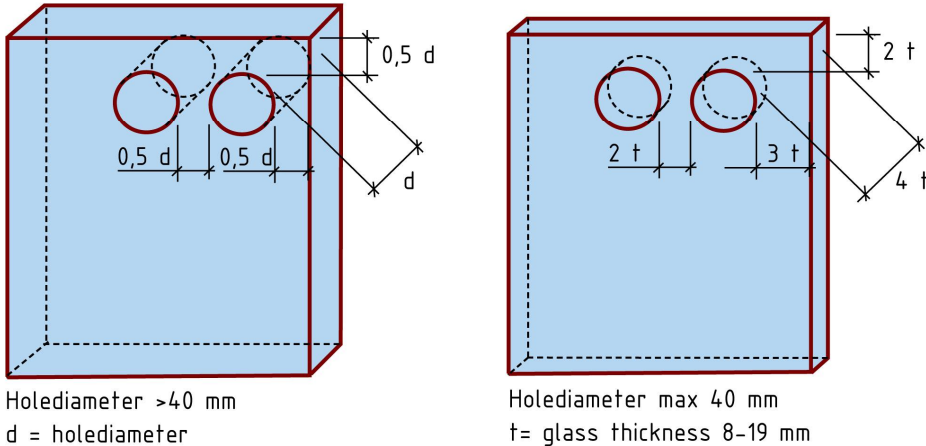

Figure 2-4 Recommendations for holes in glass [7]

2.5.2 Effects

When making a hole in glass, it has to be done from both sides at the same time. Sometimes it occurs that the two drills do not meet up properly, causing unevenness in the holes [6] (Figure 2-5). This can lead to stress concentrations that decrease the strength in the construction. Since glass is very sensitive to flaws at the surface, the holes are carefully polished to decrease the stress concentrations. The hole-making can sometimes lead to breakage. It is possible to apply loads on bolts through holes if the bolt is surrounded and insulated from direct contact with the glass by a bush or for instance nylon, like the countersunk bolt described in chapter 2.2.1.

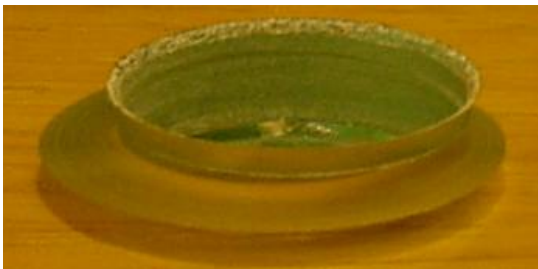

Figure 2-5 Unevenness caused when the two drills do not meet up properly

2.6 Properties of PVB, EPDM and nylon

PVB (Polyvinylbutyral) is made from polyvinyl ester and is a very important factor in the use of “safety glass”. The polymer sticks to the glass via the groups of hydroxyl. PVB is tenacious, clear and stable against sunlight [15].

Bolt fixings in toughened glass

EPDM (Ethylene-Propylene Rubber) is a soft and tenacious rubber gasket used as a bush for bolt fixings in glass, in this case for the cylindrical bolt.

Nylon is a harder plastic material, not as tenacious as EPDM and in this case also used as a bush, but for the countersunk bolt.

The properties of interest for these materials are shown in table 2-2. The properties of the PVB are taken from Monsanto Saflex [13].

Table 2-2 Mechanical properties of the materials

	E (GPa)	ν
Glass	78	0.23
PVB	0.0069 (0.0052 [*])	0.5 (0.45 [*])
Steel	210	0.30
EPDM	0.02 (0.2-2 ^{**})	0.45
Nylon	1.5	0.35

^{*}Values for the PVB in the FE-analyses (compression test)

^{**}Values of Young's modulus used for EPDM in the FE-analyses

3 Experimental determination of strength in bolt fixings in toughened glass

3.1 Background

The use of bolt fixings will result in stress concentrations around the hole in the glass. It was possible, through a simple model of a glass balustrade, to identify where the stress, acting on the glass around the fixing, is located. The purpose of the model was to bring forth a suitable experimental method to determine the strength in glass around a bolt fixing. It was found that the maximum tensions were located close to the edge of the hole on the tension side of the laminate.

Two different tests were performed, one with compressive load on bolt and another with bending load on glass. These tests would give a picture of the strength capacity in glass around the hole of a bolt fixing.

3.2 Compression test

3.2.1 Purpose

Applying a compression force on top of a bolt, affixed to the glass, results in tensile stress in the glass on the opposite side. If the strain is measured at certain locations around the hole, it is possible to obtain real values of the maximum tensile stress at failure. This gives a pretty good idea of the tensile strength of glass interacting with a bolt. When knowing the distribution of the stress, relations between loads, strength and maximum distances between holes or hole-edge can be determined. Glass interacting with a cylindrical and a countersunk bolt were tested to see if there were pronounced differences in strength around the hole when using the two different bolts.

3.2.2 Specimens for testing

Glass specimens with different thickness were used for testing with the two types of bolts, since the countersunk bolt required a thicker glass.

The glass specimens used for testing with the cylindrical bolt were 500 x 500 mm with a centric hole of 28 mm in diameter. Glass being used was 6 + 6 mm toughened laminated float glass with an interlayer of 2 x 0.38 mm PVB-film, see Figure 3-1. Since the hole had the same diameter all through the glass, it was enough to run tests with the compression force applied only in one direction.

Bolt fixings in toughened glass

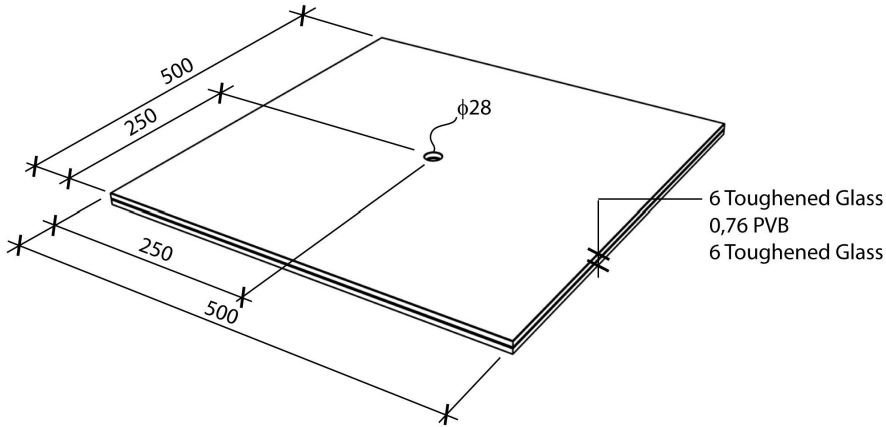

Figure 3-1 Geometry of the specimen used for the cylindrical bolt, dimensions are given in mm

The geometry of the specimens for testing with the countersunk bolt was the same, but the hole had an inner diameter of 22 mm, and an outer of 32. For this bolt the thickness of the glass was set to 8 + 8 mm, which is shown in Figure 3-2. Since the hole was different on the two sides of the glass, testing was here performed in two different ways; one, with the compression force applied on top of the bolt, and two, from underneath.

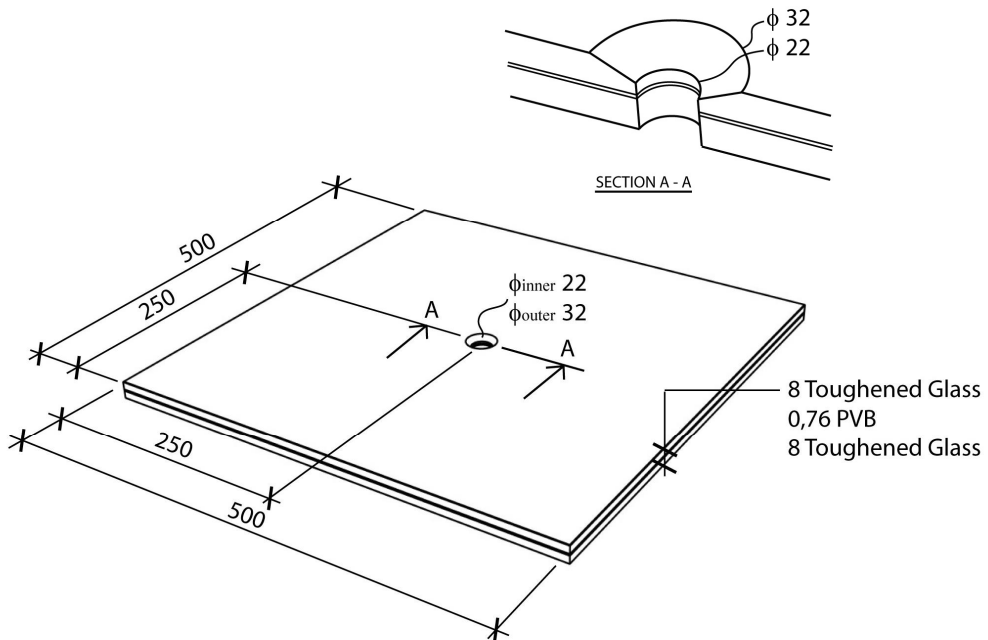

Figure 3-2 Geometry of the specimen used for the countersunk bolt, dimensions are given in mm

3.2.3 Tools and preparations

The machine used for the tensile strength tests was an MTS 810 and is shown in Figure 3-3. It is a hydraulic machine with a capacity of forces up to 100 kN.

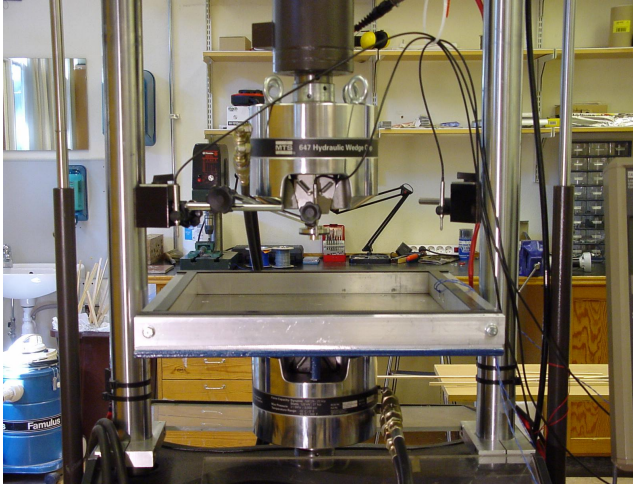

Figure 3-3 Compression test machine

As support at the edges, the glass was put on a frame of steel with a rubber gasket in between the glass and the steel. The glass specimen was lying on the frame 38 mm in from each side. The frame had the size of 500 x 500 x 38 mm as shown in Figure 3-4. The unsupported area of the specimen then became 424 x 424 mm. To establish stresses in the glass, the specimen was put on the frame while the machine applied compression force on the bolt on one side. The strain was measured on the opposite side, where the maximum tension occurred.

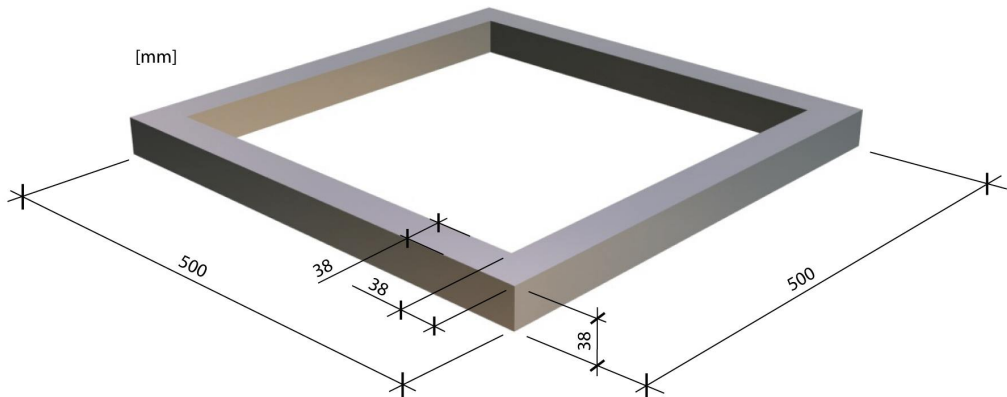

Figure 3-4 Frame that worked as support for the specimens in the compression test

To measure the deflection of the glass, there were three deflection meters (left, middle and right) connected to a computer. The deflection meters were placed as marked in Figure 3-5. The displacement of the piston was also measured.

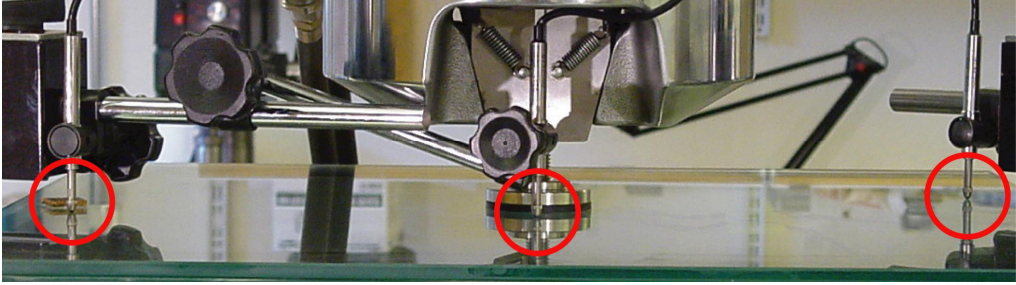

Figure 3-5 Placement of the deflection meters

Strain gauges glued onto the glass were used to measure the strain in the glass around the hole. They were glued with a special glass-glu that hardens only in UV-light. The gluing process is quite important for the outcome. The exact placement of the gauges was worked out by consideration and from the initial FE-analysis. The best location was in broad outlines very close to the hole, where the maximum (tensile) stress concentrations could be made out. They were placed according to Figure 3-6 for the countersunk bolt when pressure came from underneath. The placement of the gauges was the same for the cylindrical bolt.

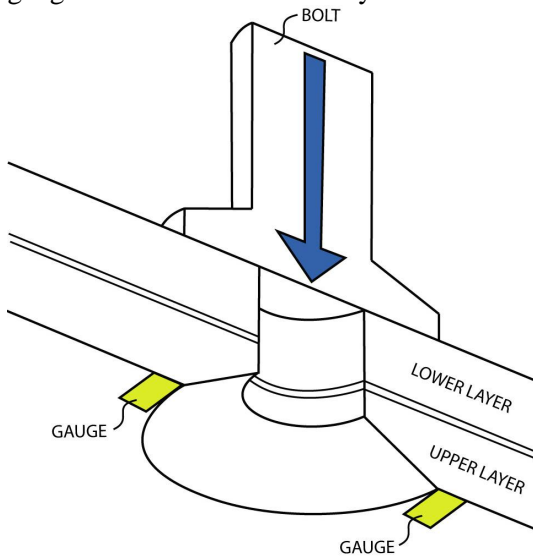

Figure 3-6 Placement of the strain gauges for the cylindrical bolt (pressure on top of bolt) and for the countersunk bolt only with pressure from underneath

For the countersunk bolt with compression force applied on top of the bolt (on the countersink of the glass), the placement of the gauges was as shown in Figure 3-7.

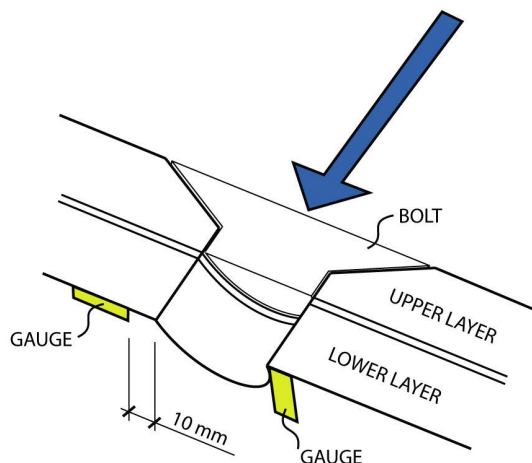

Figure 3-7 Placement of the strain gauges for the countersunk bolt with compression force applied on top of the bolt

After the gluing process the gauges had to lay in UV-light for about half an hour for the glue to harden, see Figure 3-8.

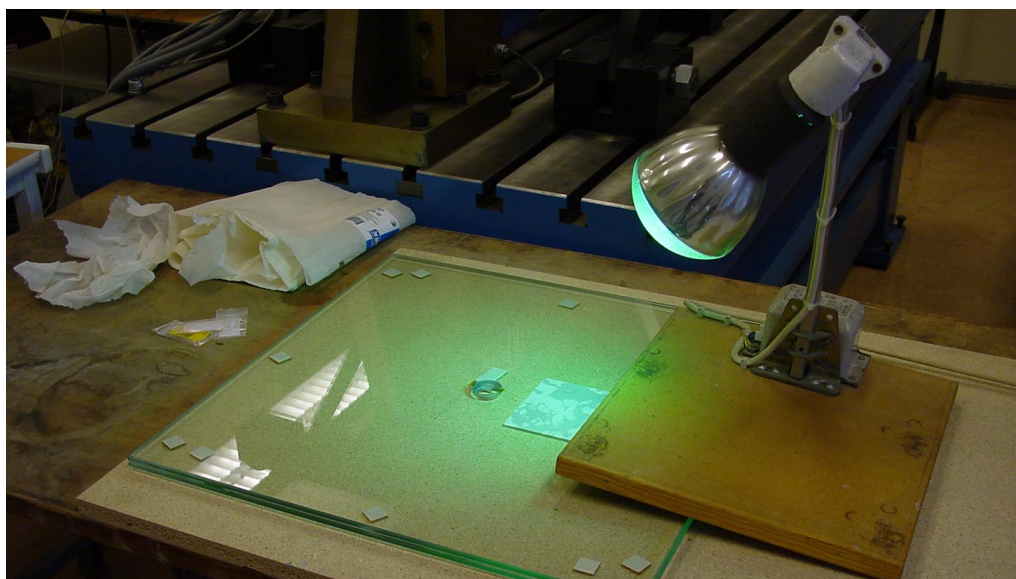

Figure 3-8 Glue-hardening process

They were then soldered to the connectors as shown in Figure 3-9, which were going via the testing machine to a computer. During the test, all the data (force, strain, deflection) was processed and shown in a table, of which diagrams were brought out later on in the work.

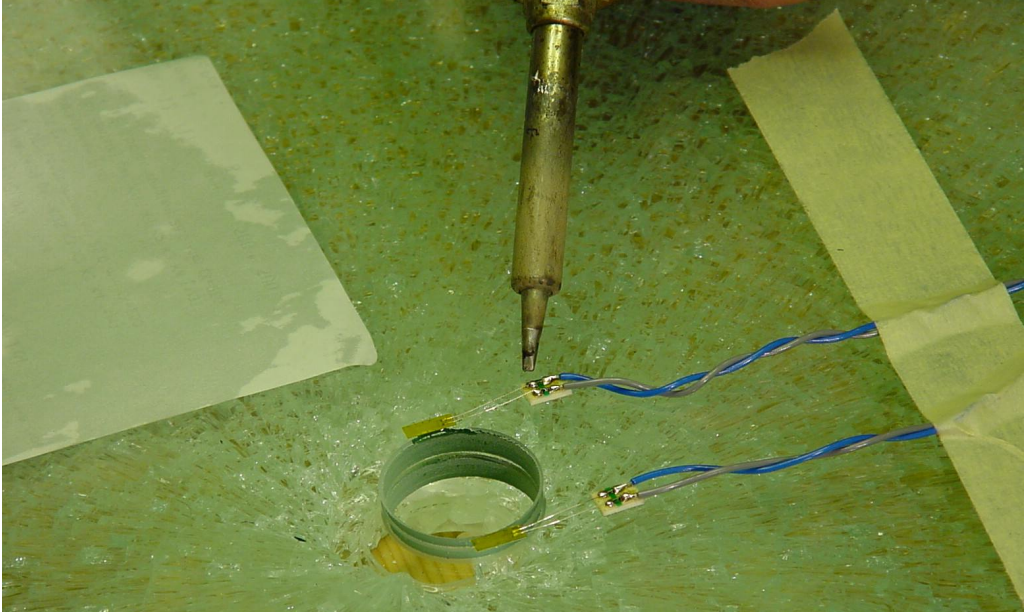

Figure 3-9 Soldering

The stress could thereafter with help from the known Young's Modulus be calculated from Hooke's law:

$$\sigma = E \cdot \varepsilon$$

σ = stress [MPa]

E = Young's Modulus [GPa]

ε = strain

How the strain gauges work is based on the theory that when a thread or a foil is subjected to a force, the area, and thus the resistance of the foil, changes. Strain can be written:

$$\varepsilon = \Delta L / L$$

L = original length

ΔL = change in length

3.2.4 Experimental test

There were three different test-cases performed, with six sets of specimens for each test-case. The experimental test set-up for all cases is shown in Figure 3-10.

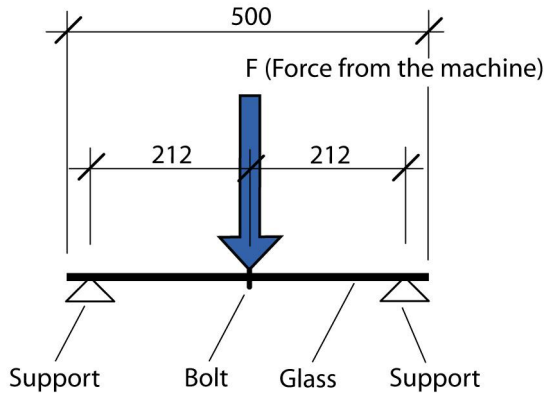

Figure 3-10 Test set-up for the compression test

Cylindrical bolt

Due to the fact the hole was cylindrical in this case, it was not necessary to run tests with compression force from each side – same distribution of the stress on both sides. It was enough to put pressure on top of the bolt so that the maximum tensile stress around the hole could be measured underneath. A small ball was placed between the piston on the machine and the bolt to make the compression force acting on the bolt as a point load. The arrangement of this test is shown in Figure 3-11.

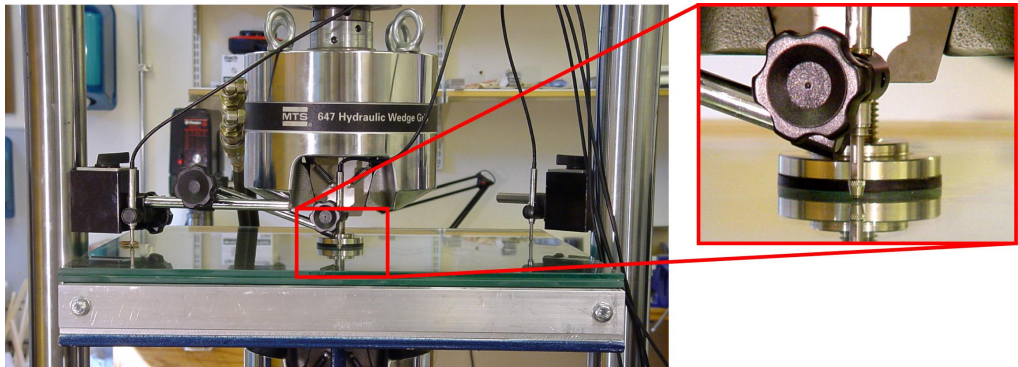

Figure 3-11 Arrangement for the cylindrical bolt

Countersunk bolt

The bolt in this case has a different design on the two sides of the glass; therefore the test was performed in two ways. One, the bolt was exposed to a compression force applied on top of the bolt, and two, pressure to the opposite side of the bolt, from underneath. This made it possible to determine for which loading direction the maximum tensile stress occur.

1. Pressure on top of the bolt

From the initial calculations made in ABAQUS, it was concluded that the principal stresses around the hole (on the “backside”) in this particular case were oriented in the radial and the tangential directions of the hole, therefore the strain gauges were put in these two directions. The concentrated load was centred on top of the bolt through a little ball and put pressure on the countersink according to Figure 3-12.

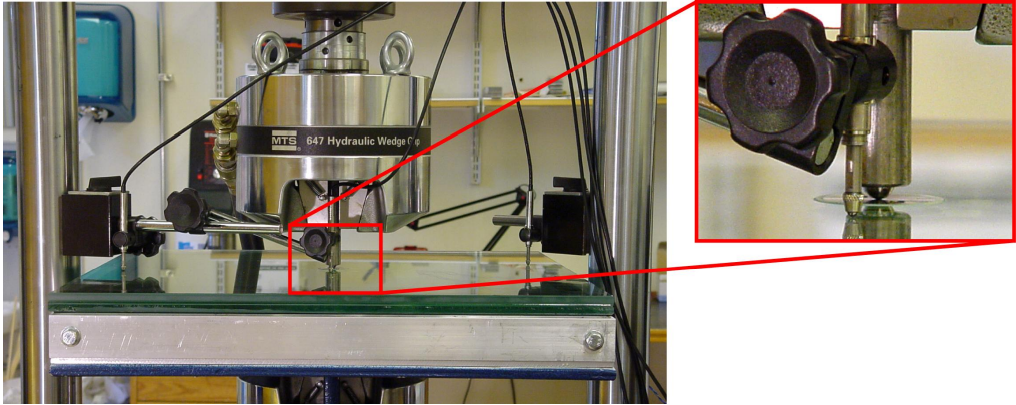

Figure 3-12 Arrangement for the countersunk bolt (pressure on top)

2. Pressure from underneath

In this case one of the principal stresses around the hole (at the countersink) was much larger, as in the case with the cylindrical bolt. Hence, the strain was measured in the tangential direction around the hole. Here the lower part of the countersunk bolt was fixed as centric as possible on the surface of the glass around the hole. The arrangement is shown in Figure 3-13.

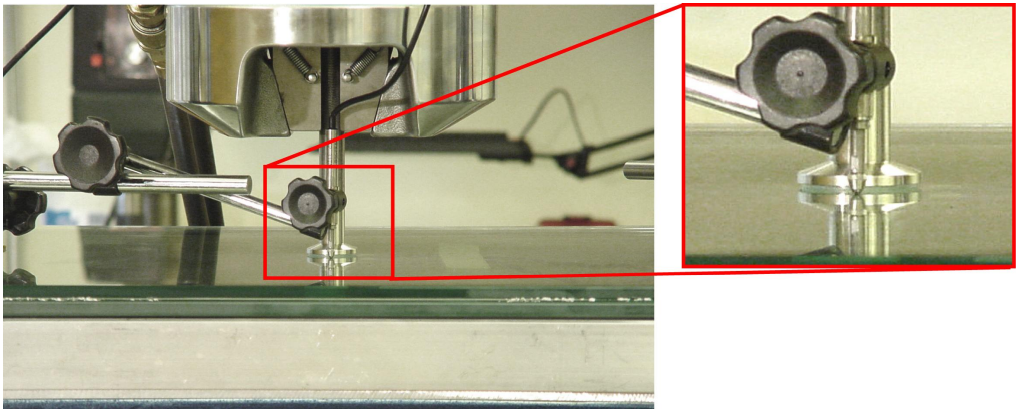

Figure 3-13 Arrangement for the countersunk bolt (pressure from underneath)

3.2.5 Results

At breakage the glass showed a brittle fracture with small harmless pieces staying inside the glass specimen, just as toughened laminated glass is known for. The fracture initiation was around the hole. Some of the glass pieces at the edges around the hole came loose as the glass broke. The fracture pattern is shown in Figure 3-14. A summary of the results was created after calculating ultimate tensile stress from each set of testing, S_{max} , mean ultimate tensile stress from each test-case, S_{mean} , and maximum force from each set of testing, F_{max} , with the mathematical program MatLab. This summary is shown in Table 3-1 to 3-3.

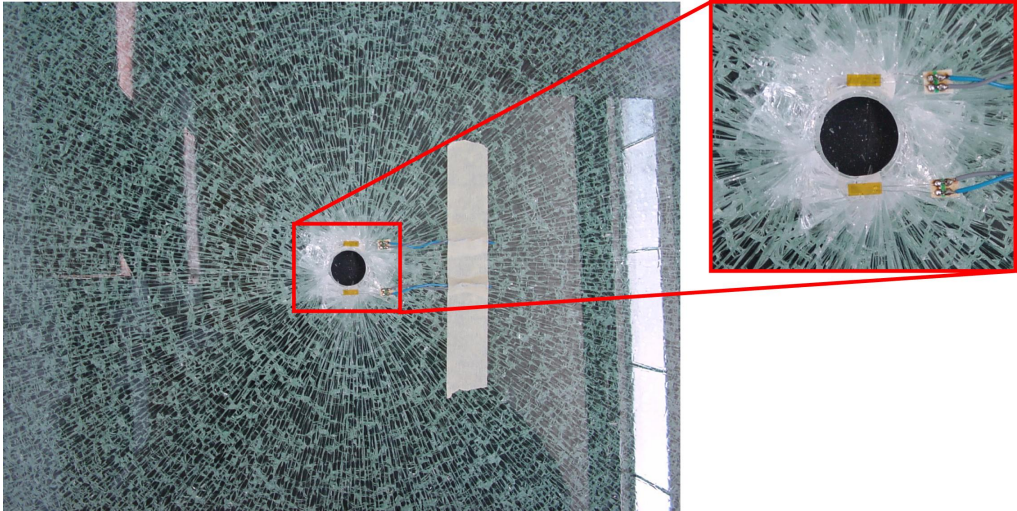

Figure 3-14 Fracture pattern of the toughened laminated glass

Cylindrical bolt

Ultimate tensile stress for the cylindrical bolt was about 202 MPa with a mean ultimate tensile stress of 177 MPa. The applied maximum force the machine reached before the glass broke was 4.8 kN. Ultimate tensile stress in the glass was reached in a test where the force was lower than max (4.7 kN) from the six sets of testing.

Table 3-1 Results from testing with the cylindrical bolt

Cylindrical bolt	Test 1	Test 2	Test 3	Test 4	Test 5	Test 6	Mean
S_{max} (MPa)	174.91	201.88	180.78	173.29	154.38	177.52	177.13
F_{max} (kN)	4.81	4.70	4.75	4.56	4.25	4.57	4.61

Bolt fixings in toughened glass

A force-displacement diagram of the results from the tests is shown in Figure 3-15. The displacement of the glass just before fracture was around 2.5-3 mm.

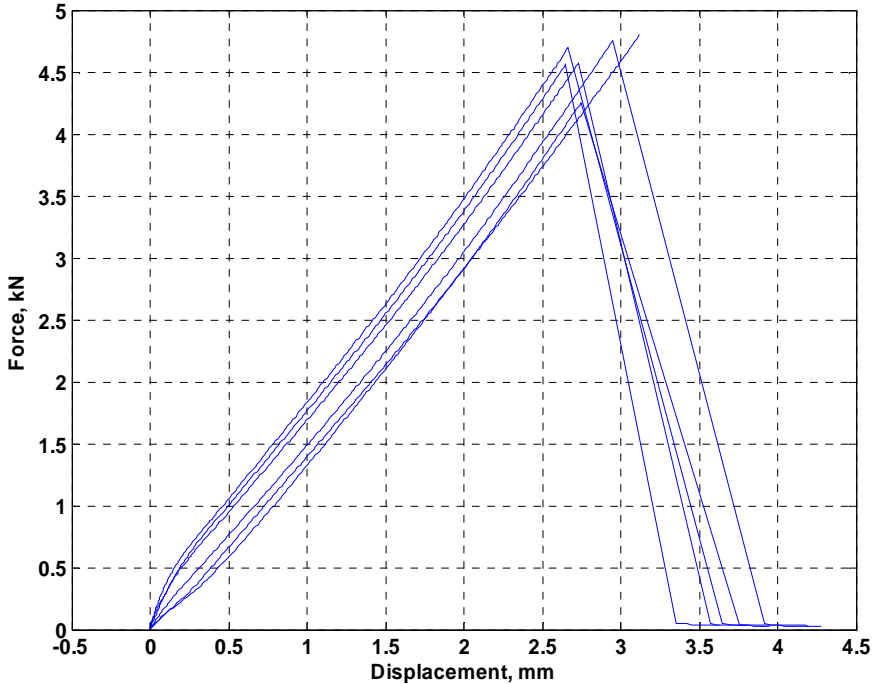

Figure 3-15 Force-displacement for the cylindrical bolt

Countersunk bolt

1. Compression force on top of the bolt

With compression force applied on top of the countersunk bolt the ultimate tensile stress was about 134 MPa with a mean ultimate tensile stress of 128 MPa. The applied maximum force the machine reached before the glass broke was here 6.3 kN. Ultimate tensile stress in the glass was reached in the same test where the force was max from the six sets of testing.

Table 3-2 Results from testing with the countersunk bolt (compression force on top)

Countersunk (pressure on top)	Test 1	Test 2	Test 3	Test 4	Test 5	Test 6	mean
S_{\max} (MPa)	123.98	133.61	133.02	132.19	121.76	122.05	127.77
F_{\max} (kN)	5.50	6.32	5.52	5.86	5.92	4.95	5.68

Some data is plotted in the diagram in Figure 3-16. In this case, the displacement of the glass at fracture was around 1.5-2 mm.

Bolt fixings in toughened glass

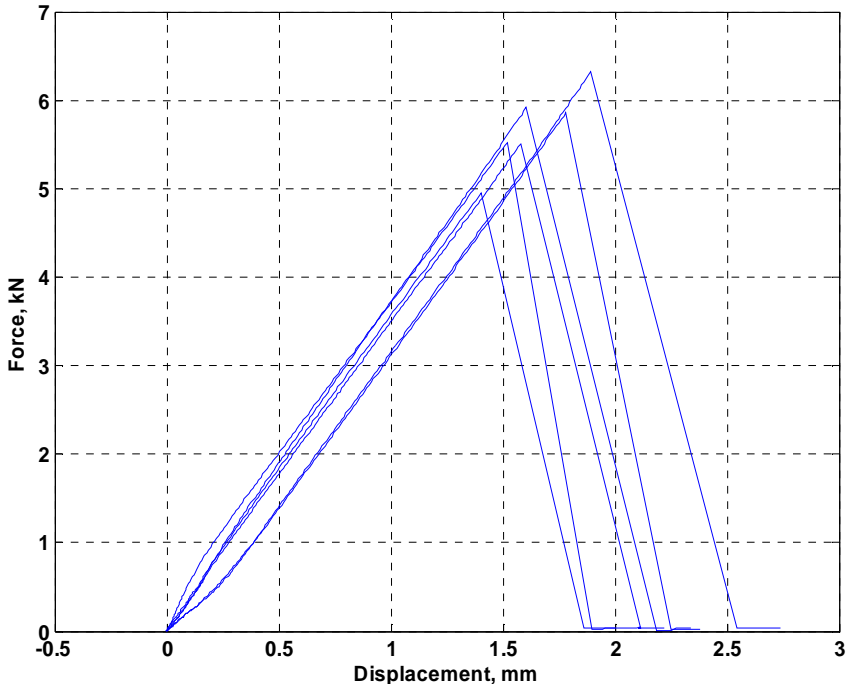

Figure 3-16 Force-displacement for the countersunk bolt with pressure on top of bolt

2. Compression force from underneath

With compression force applied to the countersunk bolt from underneath, the ultimate tensile stress was about 150 MPa with a mean ultimate tensile stress of 140 MPa. The applied maximum force the machine reached before the glass broke was here 7.5 kN. Ultimate tensile stress in the glass was reached in a test where the force was lower than max from the six sets of testing.

Table 3-3 Results from testing with the countersunk bolt (pressure from underneath)

Countersunk (pressure from underneath)	Test 1	Test 2	Test 3	Test 4	Test 5	Test 6	mean
S_{\max} (MPa)	146.85	150.04	139.00	147.10	132.57	126.23	140.30
F_{\max} (kN)	6.81	7.33	7.42	7.52	7.15	7.10	7.22

Diagram in Figure 3-17 shows the relation between maximum force and displacement. Maximum displacement was around 2 mm.

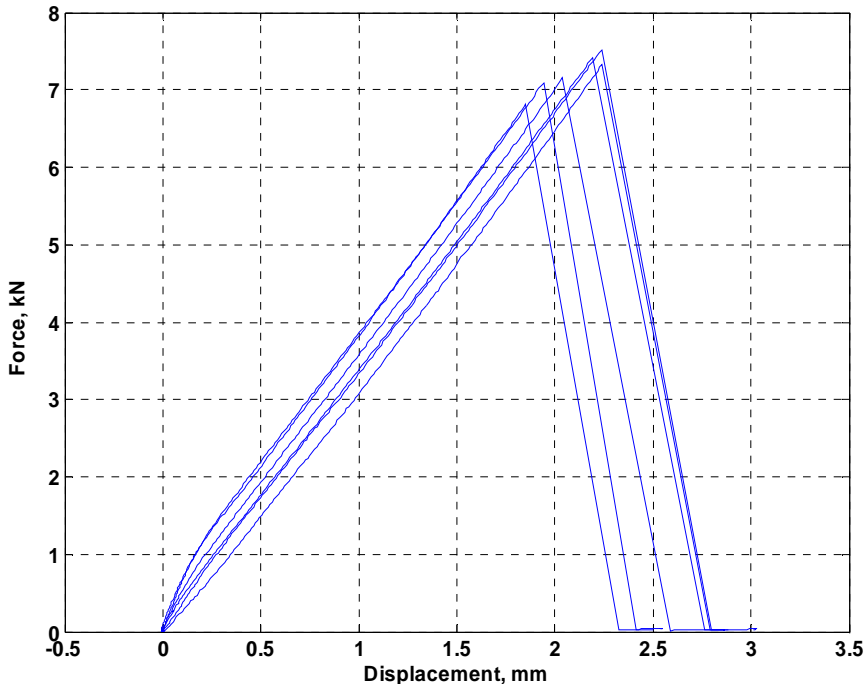

Figure 3-17 Force-displacement for the countersunk bolt with pressure from underneath

3.2.6 Discussion

The first thing to comment is the number of sets of testing. When there are only six sets of testing it can be hard to evaluate the results. The statistical basis may not be quite enough to do statistical analysis on the breakage stresses to get a design tool, but even though there are a few sets of testing the spread in this particular case was kind of narrow. That means the results from above may be veracious enough to be used in future calculations.

A difference can be seen between the two thicknesses of the glass. The stress at the hole in the glass for the cylindrical bolt is larger than in the glass for the countersunk bolt. On the other hand the thinner glass (for the cylindrical bolt) breaks at a lower load, which possibly can be explained by the thinner the glass, the easier it breaks. The deflection is larger when the glass is thinner, which makes it a bit harder to compare the two bolt fixings from experiments only.

Another important and maybe conclusive explanation to the difference in the stresses at failure may be the manufacturing process. During the toughening the compressive state at the surface and the internal tensions are created and when there is a big difference between the compressive state at the surface and the internal tensions, the glass breaks easier. If there is not enough accuracy during inspection of the cooling process, the glass panes will end up with a various number of defects with different sizes, which results in different strength. It is very hard to control this to the fullest since the defects are invisible to the eye. It also usually differs between different manufacturers. If the glass is thicker it also has more volume to contain more defects

starting fissures so if the volume effect is applied, the glass should be weaker with increased volume.

Another thing in the production that may have an effect on the result is the drilling and polishing of the holes, especially the countersunk holes. After the drilling the cut surface of the glass has to be polished, due to a different amount of defects on the surface. The remaining defects after polishing are still able to initiate fractures. The bigger the area of “worked” glass, the bigger the risk of failure.

When gluing the strain gauges, there could be some differences between effective surfaces of the gauges from specimen to specimen, depending on how much glue being used and for how long the glue hardening process was set to. Therefore, this procedure also had an effect on the outcome.

3.3 Bending test

3.3.1 Purpose

To be able to investigate how the stress distribution around the hole develops for a bolt fixing loaded by a moment, a bending test was performed. A line-load was put on top of the glass pane to bring forth the bending moment. This would give a more real picture of what a fixing on a glass balustrade is exposed to. In this case only one bolt is affixed in the lower part of the pane. Bending causes a bending moment and shear forces are also acting on the glass, why it can be tricky to determine the exact value of each component.

3.3.2 Specimens for testing

The geometry of the specimen used for bending is shown in Figure 3-18. This had the same height as a glass balustrade which in this case is 1300 mm including the thickness of the slab, on which the glass is affixed. The width of 500 mm was chosen since a distance of 250 mm to an external edge was desired. The thickness of the glass and the diameter of the hole was the same as for the compression test with the cylindrical bolt.

Bolt fixings in toughened glass

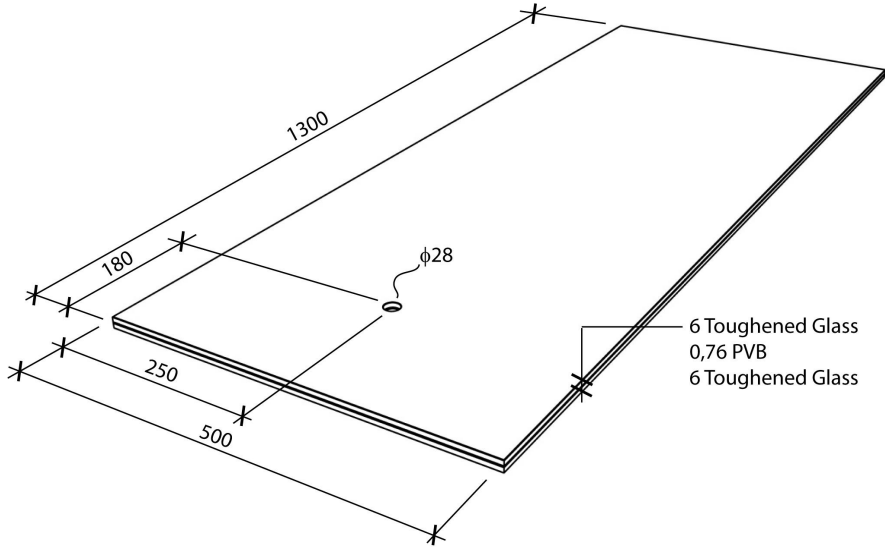

Figure 3-18 Geometry of the specimen used for bending (cylindrical bolt), dimensions given in mm

3.3.3 Tools and preparations

The machine used for the bending test was a MTS also but with a capacity of 250 kN and is shown in Figure 3-19 with the test set-up.



Figure 3-19 MTS machine and the experimental test set-up for the bending test

Bolt fixings in toughened glass

A deflection meter was connected to the glass at the location of the bolt and the strain gauges were placed as for the compression test with the cylindrical bolt. Here though, a small problem with the placement of the gauges occurred since the EPDM in between the bolt and the glass obstructed the measuring. The gasket had to be cut as in Figure 3-20 to make room for the strain gauges to measure the strain close to the edge of the hole. Since the location of the strain gauges on the glass was at the tension side, the cuts in the EPDM were located where unloaded when the bending occurred. The measuring from the gauges may have been affected by this.



Figure 3-20 Cut out of the EPDM to make room for the strain gauges

The bolt had to be affixed very tight to decrease the large deflection of the arrangement, which resulted in a squeezed EPDM. The bolt affixed to the glass is shown in Figure 3-21.

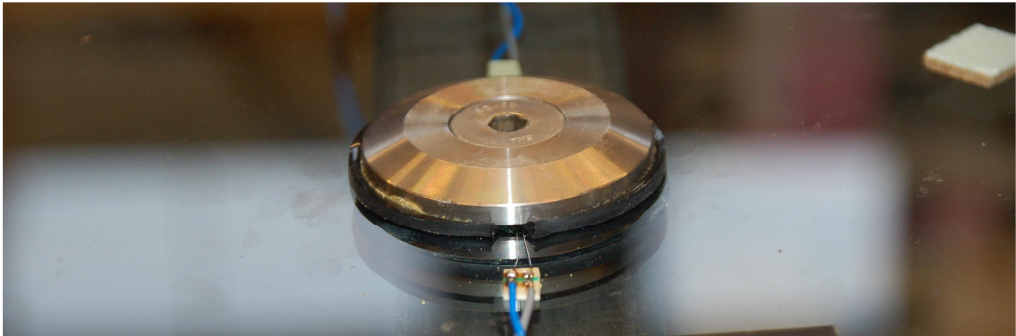

Figure 3-21 Bolt affixed to the glass

The glue-hardening process and the soldering were carried out in the same manner as for the compression test.

3.3.4 Experimental test

A sketch of the experimental test set-up for the bending test is shown in Figure 3-22. The aim was to simulate the bending procedure of the glass pane. The glass was simply supported in the upper end and screwed onto a 400 mm long lever arm with a cylindrical bolt. The lever arm was simply supported at one end and placed on the bolt, which was fixed as tight as possible onto the glass, at the other end. A small ball was placed between the nut on the lever arm and the piston on the machine. The lever

Bolt fixings in toughened glass

arm was placed on the compression side of the glass as shown in Figure 3-22 to ensure that the lever arm would not come into contact with the glass.

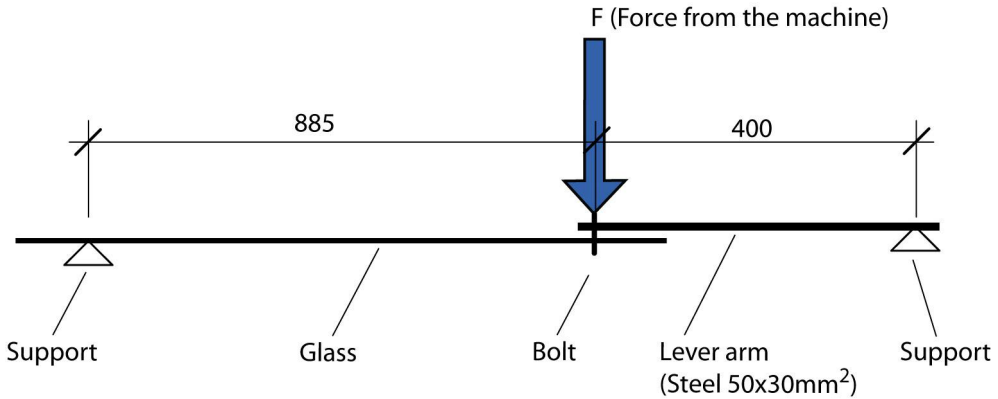

Figure 3-22 Test set-up for the bending

The moment at the bolt is given by:

$$M = F \frac{0.885 \cdot 0.400}{0.885 + 0.400}$$

M is the moment at the bolt and F is the measured load from the testing machine.

3.3.5 Results

The results in Figure 3-23 indicate a pretty narrow spread for the measured force versus displacement. The calculated moment at the bolt, plotted in Figure 3-24, show the same accuracy. The stress calculated from the strain gauges, shown in Figure 3-25, on the other hand, shows a vast spread. The maximum moment at the bolt was around 200 Nm, calculated from an applied force from the machine of just above 700 N. The results from the bending test are shown in Table 3-4.

Table 3-4 Results from the bending test

Cylindrical bolt (bending)	Test 1	Test 2	Test 3	Test 4	Test 5	mean
F_{\max} (N)	760.35	746.11	703.80	704.83	754.45	733.91
M_{\max} (Nm)	209.47	205.54	193.89	194.17	207.84	202.18
S_{\max} (MPa)	47.33	30.52	36.16	39.13	-	38.29

For comparison, the characteristic line-load from Swedish standards was converted into a moment. For the 0.5 m wide glass pane used for the bending test and with a distance of 885 mm from bolt to application of the line-load (800 N/m), the line-load was roughly translated into a moment of $800 \times 0.5 \times 0.885 = 354$ Nm

A maximum moment of 200 Nm as determined from the experiments corresponds to a line-load of about 450 N/m. The deflection at failure was between 40 and 50 mm.

Bolt fixings in toughened glass

The deflection is, however, strongly dependent on the deformation of the EPDM-gasket and comparisons of the deflection is therefore irrelevant.

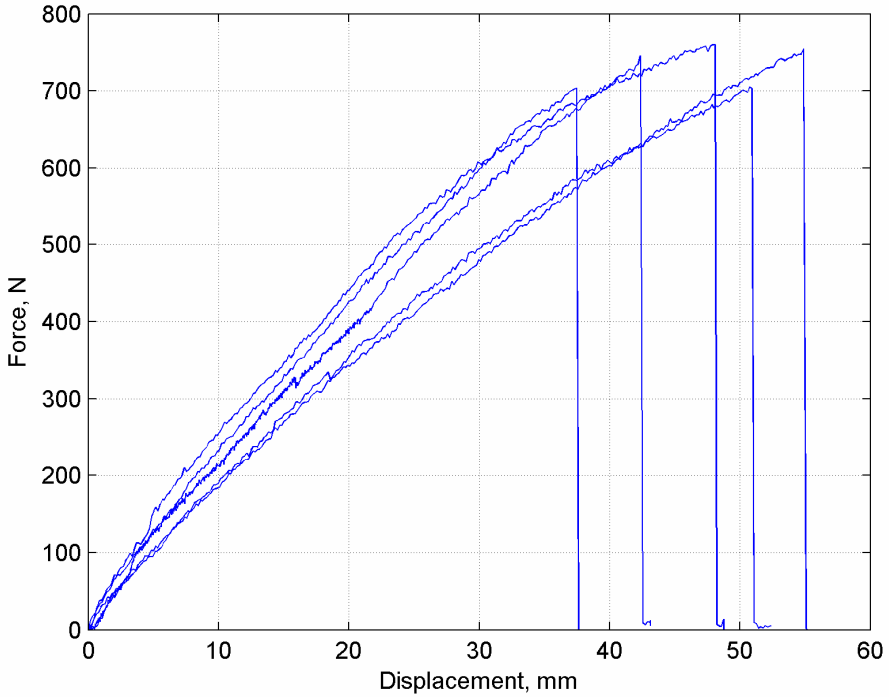

Figure 3-23 Force-displacement diagram for bending

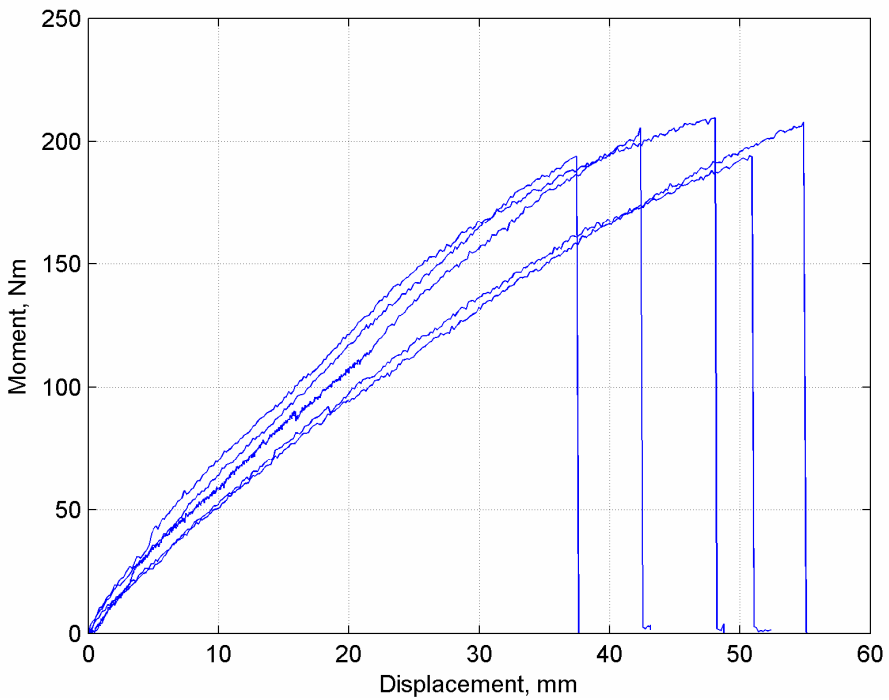

Figure 3-24 Moment-displacement diagram for bending

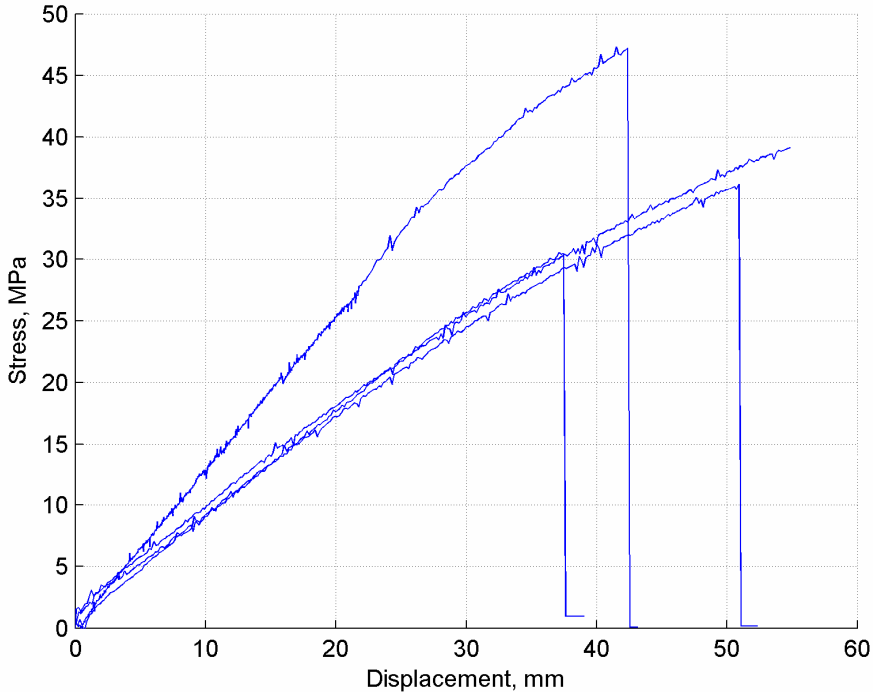

Figure 3-25 Stress-displacement diagram for bending

3.3.6 Discussion

As mentioned above it is hard to evaluate the results due to the few sets of testing. A couple of conclusions and comments for future work can still be done. The measured stress is not necessarily the maximum, since the strain gauges could not be placed in between the glasses, where the stress concentrations may have been larger.

The placement of the strain gauges for the bending test was not optimal considering bringing forth maximum tension. Instead of placing them close to the edge of the hole, the best location in this case would have been right beside the edge of the spreader plate since this is moving the stress away from the hole to around its edge. When bending the glass pane, large stress gradients arise at the hole, which means a big difference in measured stress even if only a minimal change is done to the placement of the strain gauges.

Still the bending test shows that the glass pane with only one bolt of this kind can not take a moment more than around 200 Nm. According to the Swedish standards, a line-load of 800 N/m (without safety factors) should be required for a railing. Roughly calculated, this bending test corresponds to a line-load of about 450 N/m, which is approximately half the required capacity.

A deflection as large as 40-50 mm for a railing made of glass may cause psychological uncomfortable feelings. There can in most cases also be tricky to make room for this kind of bending around the building structure.

4 FE-modelling of the experimental methods

4.1 FE-method

The finite element method is a numerical method being used to solve problems where differential equations can be solved with approximation. The differential equations that are describing a physical problem, apply to a certain body. This volume, which can be one-, two- or multivariate, is in the finite element method divided into small regions, finite elements. This subdivision is made to be able to approximate over every single element instead of the whole area. Variables that can vary non-linear over the whole area can be presumed to vary linear over every element. The gathered elements are called a finite element mesh. After choosing appropriate approximation over each element, the properties of the elements are calculated. This can be done since the approximation over each element is relatively simple. When this is done, the elements are connected to create the whole area, which from a foregone load gives an approximate solution for the behaviour of the whole body. [11]

4.1.1 ABAQUS

The program used for the FE-analysis is ABAQUS/CAE version 6.4/6.5. ABAQUS is a series of programs based on the finite element method, suitable to solve problems all from simple linear analysis to the most complicated nonlinear simulations. It is, thanks to the huge model database of materials, possible to simulate the typical behaviour of construction materials such as metals, rubber, polymer, composites, reinforced concrete etc. ABAQUS can be used for structural problems, acoustics, soil mechanics etc.

4.2 Purpose

The test set-ups were analysed as thorough as possible in ABAQUS to be able to vary some parameters and study the result without further testing in the lab. Moreover, by comparing the models with the experiments, strength criteria for glass may be developed.

4.3 Prerequisites

A standard linear three-dimensional eight-node stress element with reduced integration (C3D8R) was used. To reduce the number of elements in the compression test analysis a symmetry plane was employed, thus the whole set-up for all cases was divided in the middle. Structural meshing was chosen and partitioning was used to divide the geometry into smaller regions.

4.4 Compression test

4.4.1 Geometry

All geometry of the bodies is the same as for the experimental tests. The glass was simulated to be simply supported by the frame which also was included in the analysis. For the compression tests the size of the glass was affected by the frame, which means the effective surface was the total surface of the glass minus the contact surface between the glass and the frame.

1. Pressure on top of the bolt

The things that differ the modelling of the case with the cylindrical bolt and the case with the countersunk bolt were the thickness of the glass, the countersunk hole, the geometry of the bolt and the material of the bush.

2. Pressure from underneath

To simulate the pressure coming from underneath, the frame was put “on top” of the glass with pressure from underneath. This was done only in the case with the countersunk bolt.

4.4.2 Materials

Materials and material parameters being used were the ones described in chapter 2, except for Young’s modulus of the PVB, which was set to 5.2 MPa in the modelling and the Poisson’s ratio, here 0.43. They are all linear elastic and isotropic materials, modelled as solid homogeneous and deformable, except for the frame, which was made as a discrete rigid body, all shown in Table 4-1. The important parameters were Young’s modulus and Poisson’s ratio for each material. For the EPDM, Young’s modulus was set to 0.2 GPa.

4.4.3 Modelling

The modelling of the compression tests was performed in the same way for all cases. The big difference was the placement of the frame, which in the case with the countersunk bolt and pressure from underneath was “on top” of the glass and the deflection had to be set upwards. The frame was acting as a still support where the glass was able to lift from the frame. Interaction with the type surface-to-surface contact was set between glass and EPDM plus frame and glass with a tangential behaviour, a friction formulation called penalty and a friction coefficient of 0.19, to establish a realistic friction between the materials. The bolt was connected to the bush (EPDM or nylon) by constraints with the type tie, which means that the nodes along the surfaces interact without any relative movement between each other. The frame had the constraint type set to rigid body with the region types body and tie and a reference point. There were about 25 000 elements; 4 elements in thickness direction for each glass layer and 2 elements in thickness for the PVB layer.

4.4.4 Loads and boundary conditions

To simulate the load for the compression test, the bolt (the flat surface on top of the bolt) was set to have a displacement of 3 mm downwards. To lock possible movement in other directions the bolt was set to have no displacement in one direction. The whole surface of all parts of the symmetry plane was set to have no movement perpendicular to that surface. The frame was constrained to zero displacement everywhere.

The modelling of the compression test is summarized in Table 4-1.

Table 4-1 Modelling of the compression test

	Cylindrical bolt		Countersunk bolt	
Glass	6+6 mm Glass	Solid, homogeneous, deformable	8+8 mm Glass	Solid, homogeneous, deformable
Interlayer	0.76 mm PVB*		0.76 mm PVB*	
Bolt	Steel	Shell, discrete rigid	Steel	Shell, discrete rigid
Bush	EPDM (E=0.2 GPa)		Nylon	
Frame				
Interactions	Glass-EPDM Frame-Glass <ul style="list-style-type: none"> • Surface-to-surface contact • Tangential behaviour • Friction formulation: Penalty • Friction coefficient: 0.19 		Glass-Nylon Frame-Glass <ul style="list-style-type: none"> • Surface-to-surface contact • Tangential behaviour • Friction formulation: Penalty • Friction coefficient: 0.19 	
Boundary conditions	Deflection: U1=0, U2=-3 mm Symmetry: U3=0 Lock frame: All nodes=0		Deflection: U1=0, U2=-3 mm Symmetry: U3=0 Lock frame: All nodes=0	
Constraints	Bolt-EPDM <ul style="list-style-type: none"> • Tie Frame <ul style="list-style-type: none"> • Rigid body - Tie 		Bolt-Nylon <ul style="list-style-type: none"> • Tie Frame <ul style="list-style-type: none"> • Rigid body - Tie 	

*E=5.2 MPa and $\nu=0.43$ for the PVB

4.4.5 Results

The results from the modelling are shown in plots obtained from the simulations in ABAQUS. There are three plots of curves and one visual plot for each test-case. One force-displacement plot that corresponds to the experimental force-displacement diagram, one force-stress plot with the tensile stress taken from the area where the strain gauges were glued, that also may be compared with the experimental results and finally, one from the lower glass right next to the PVB where the largest stresses was found. The visual plot shows the location of the maximum principal stress.

Cylindrical bolt

A force-displacement plot in Figure 4-1 shows an almost linear curve, and there were similarities with the corresponding experimentally obtained diagram in Figure 3-15.

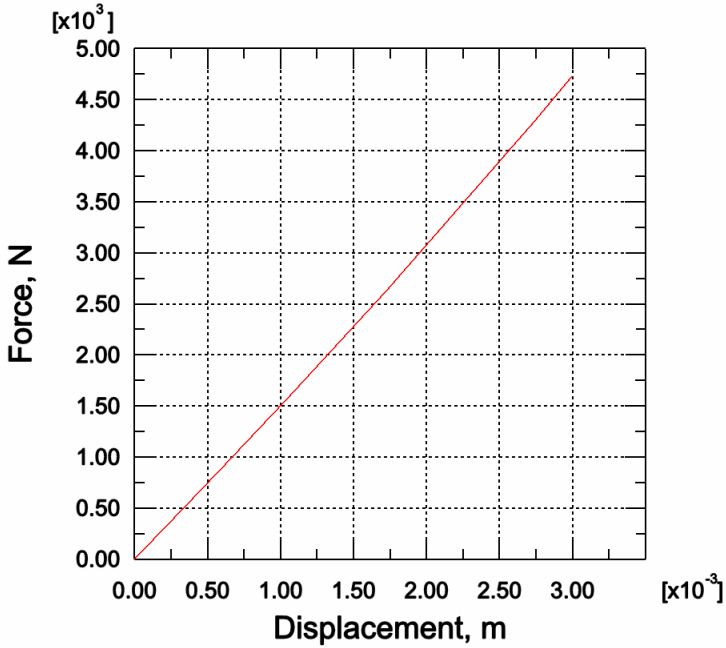

Figure 4-1 Force-displacement for the cylindrical bolt

The force-stress plot in Figure 4-2 shows a slightly lower stress than the result from the experimental tests when comparing to the figures in Table 3-1. The curve in Figure 4-3 indicates a higher value of the stress, which means that the maximum stress is located in between the glasses, by the PVB. The location of the maximum principal stress is shown in Figure 4-4.

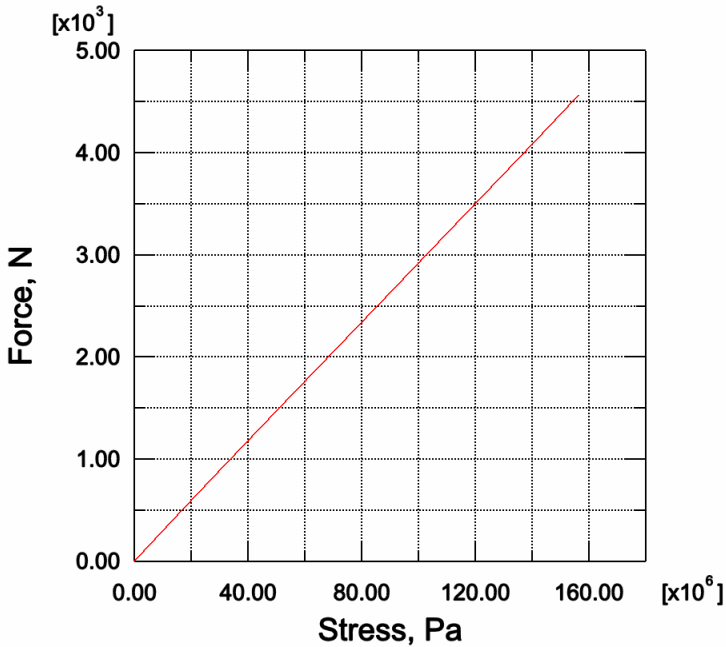

Figure 4-2 Force-stress for the cylindrical bolt

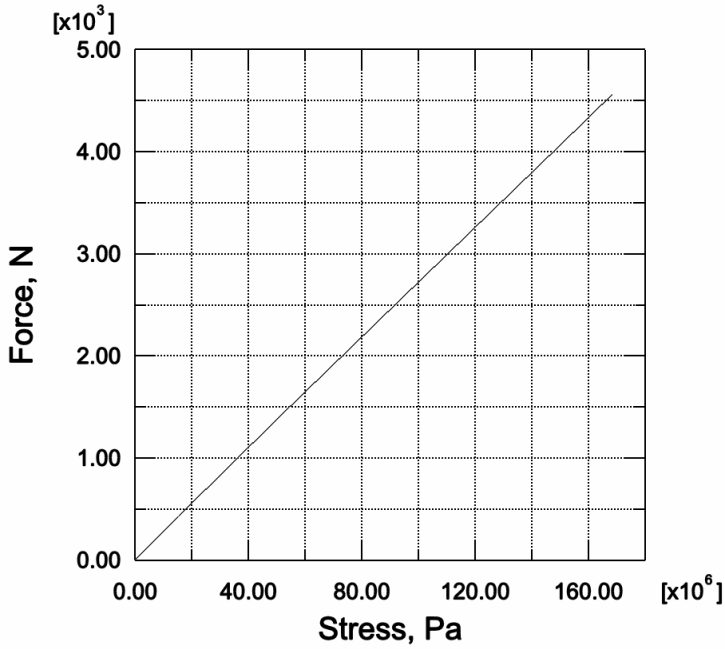

Figure 4-3 Force-stress for the lower glass where it interacts with the PVB (cylindrical bolt)

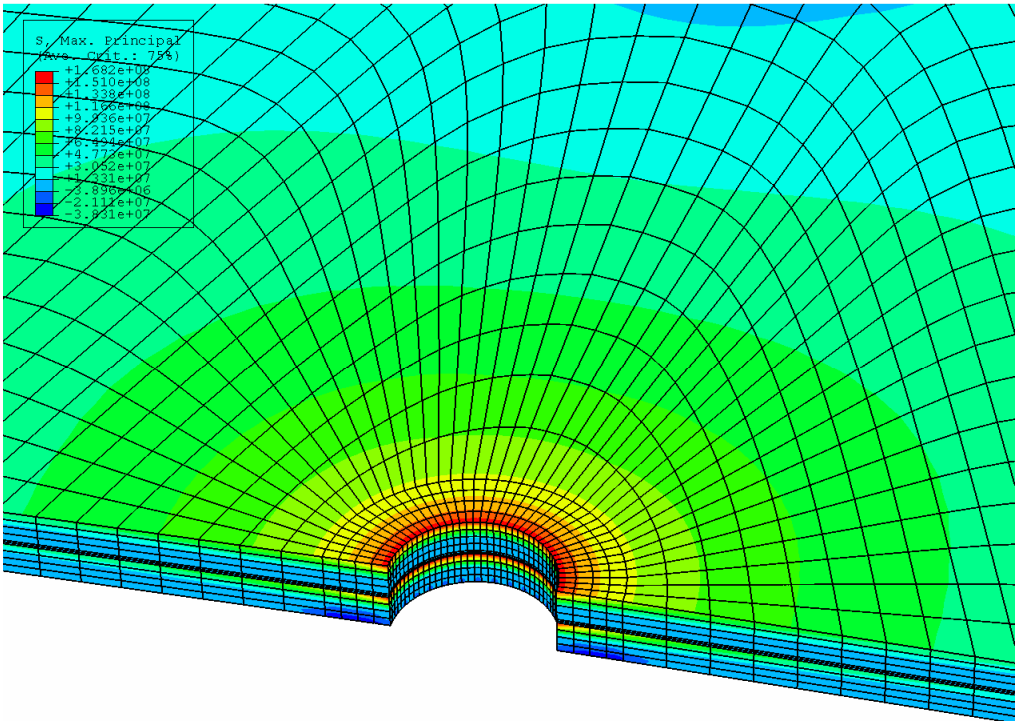

Figure 4-4 Maximum principal stress for the cylindrical bolt

Countersunk bolt

1. Compression force on top of the bolt

A force-displacement plot in Figure 4-5 shows a linear curve, which is almost the same as the corresponding diagram found from the experimental tests as shown in Figure 3-16.

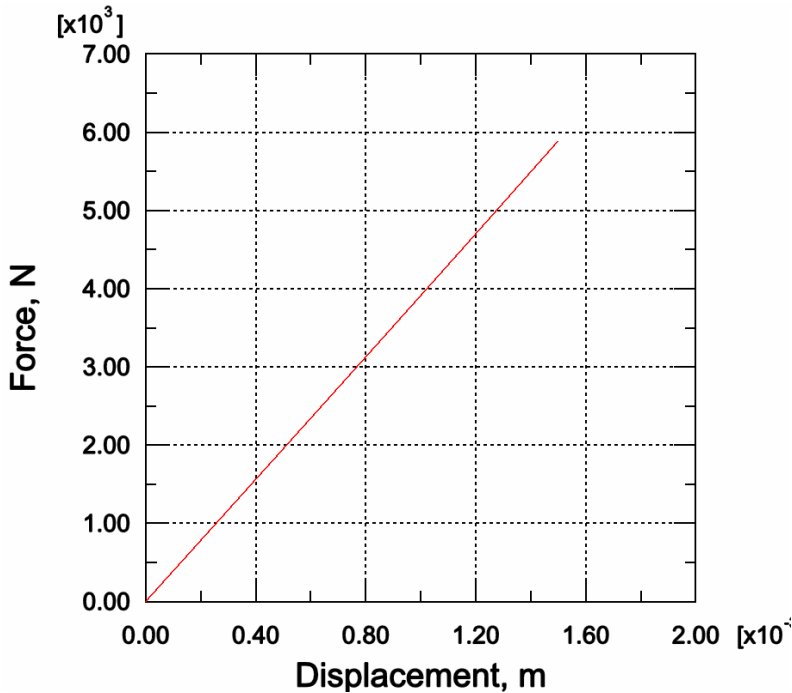

Figure 4-5 Force-displacement for the countersunk bolt (force on top of bolt)

The force-stress plot in Figure 4-6 shows a bit lower stress than the results from the experimental tests when comparing to the figures in Table 3-2. The curve in Figure 4-7 indicates a flatter inclination, which means that the maximum stress here also is located in between the glasses, by the PVB. The location of the maximum principal stress is shown in Figure 4-8.

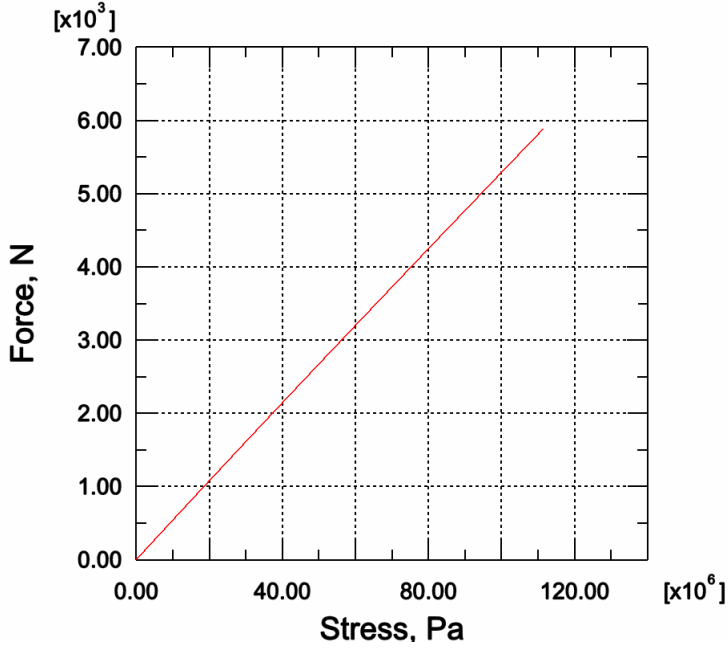

Figure 4-6 Force-stress for the countersunk bolt (force on top of bolt)

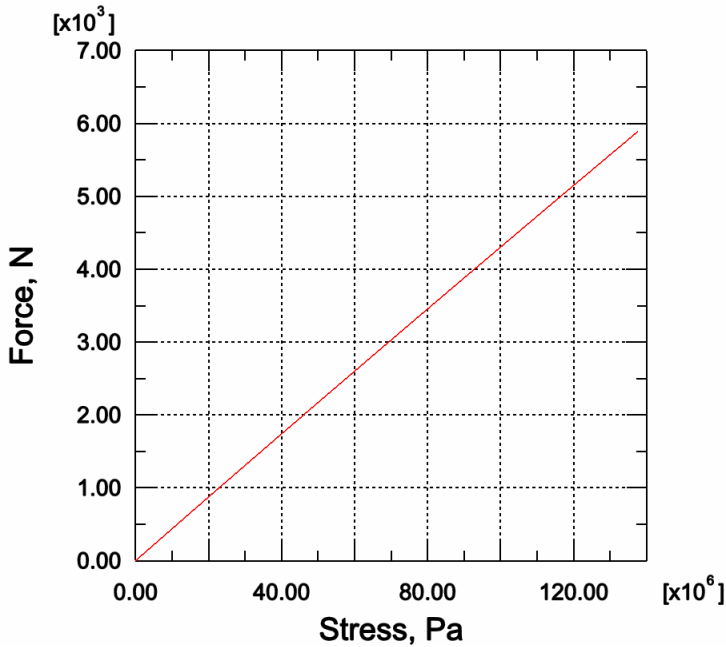

Figure 4-7 Force-stress for the lower glass where it interacts with the PVB (countersunk bolt, pressure on top)

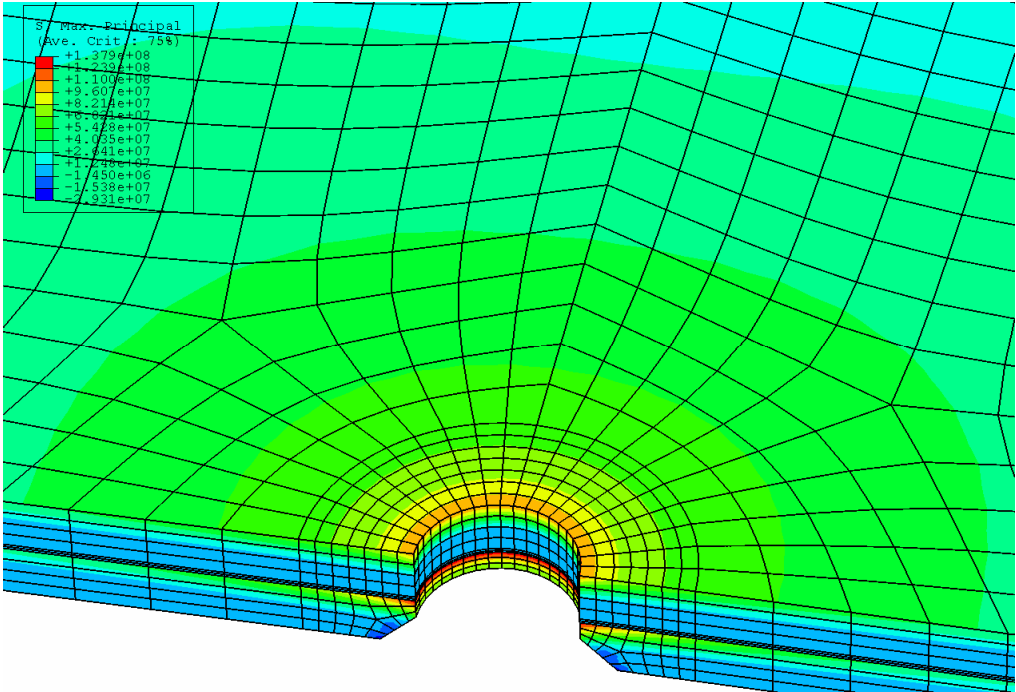

Figure 4-8 Maximum principal stress for the countersunk bolt with pressure on top of bolt

2. Compression force from underneath

Figure 4-9 also shows a linear curve that almost corresponds to the curve in the force-displacement diagram in Figure 3-17.

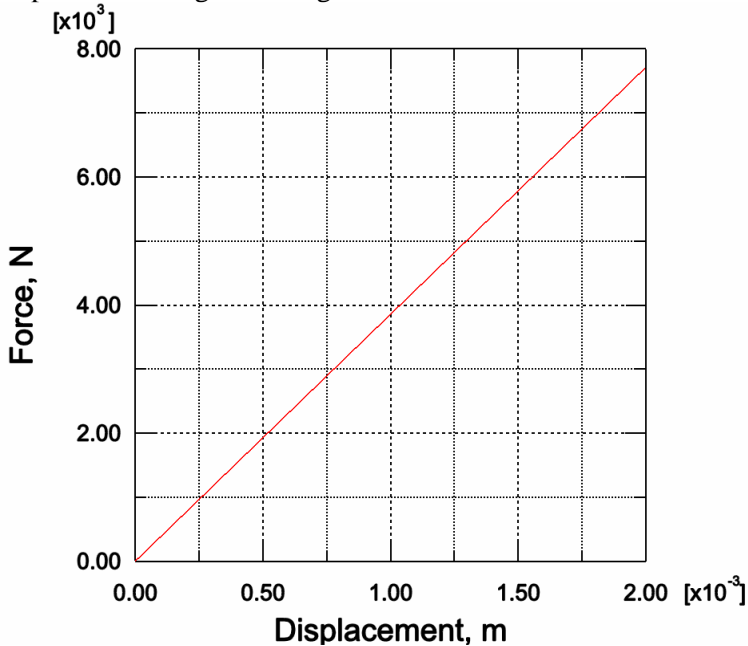

Figure 4-9 Force-displacement for the countersunk bolt (force from underneath)

Bolt fixings in toughened glass

The force-stress plot in Figure 4-10 shows a lower stress than the results from the experimental tests when comparing to the figures in Table 3-3. The curve in Figure 4-11 has the same tendency as the previous force-stress plots; there is more stress inside the construction. The maximum stress is, in other words, also in this case located in between the glasses, by the PVB. The location of the maximum principal stress is shown in Figure 4-12.

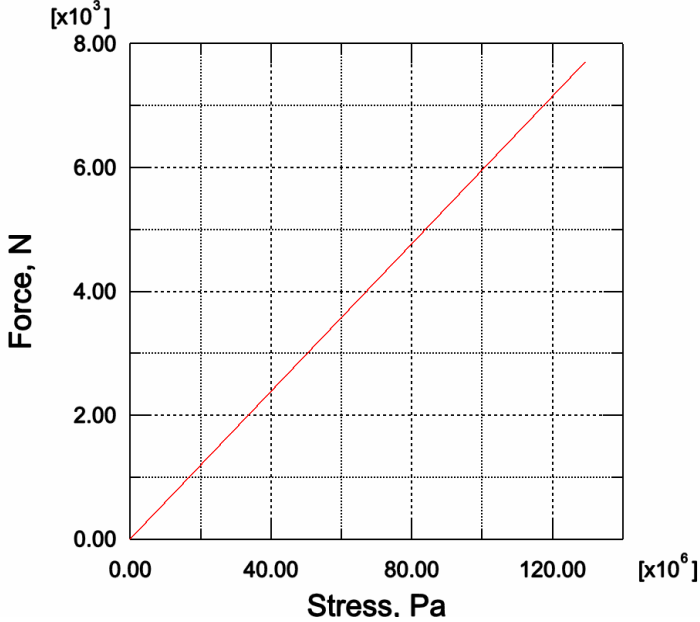

Figure 4-10 Force-stress for the countersunk bolt (force from underneath)

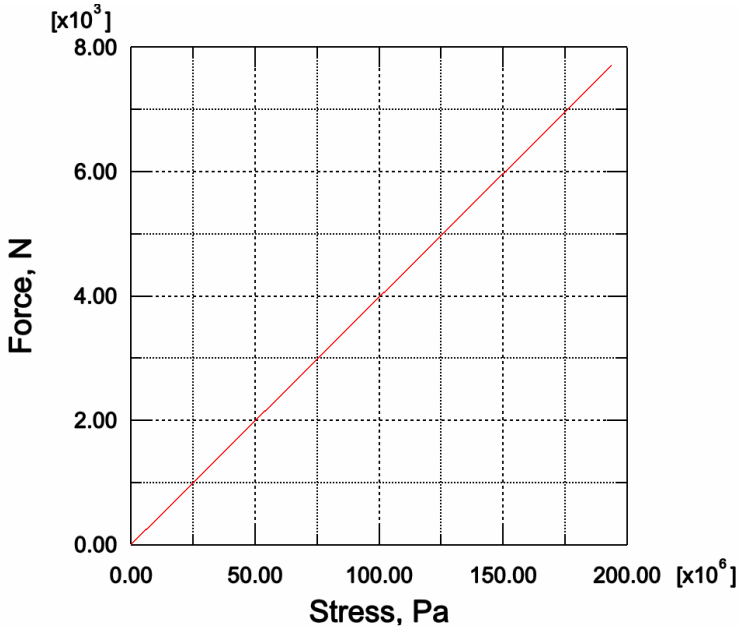

Figure 4-11 Force-stress for the lower glass where it interacts with the PVB (countersunk bolt, pressure from underneath)

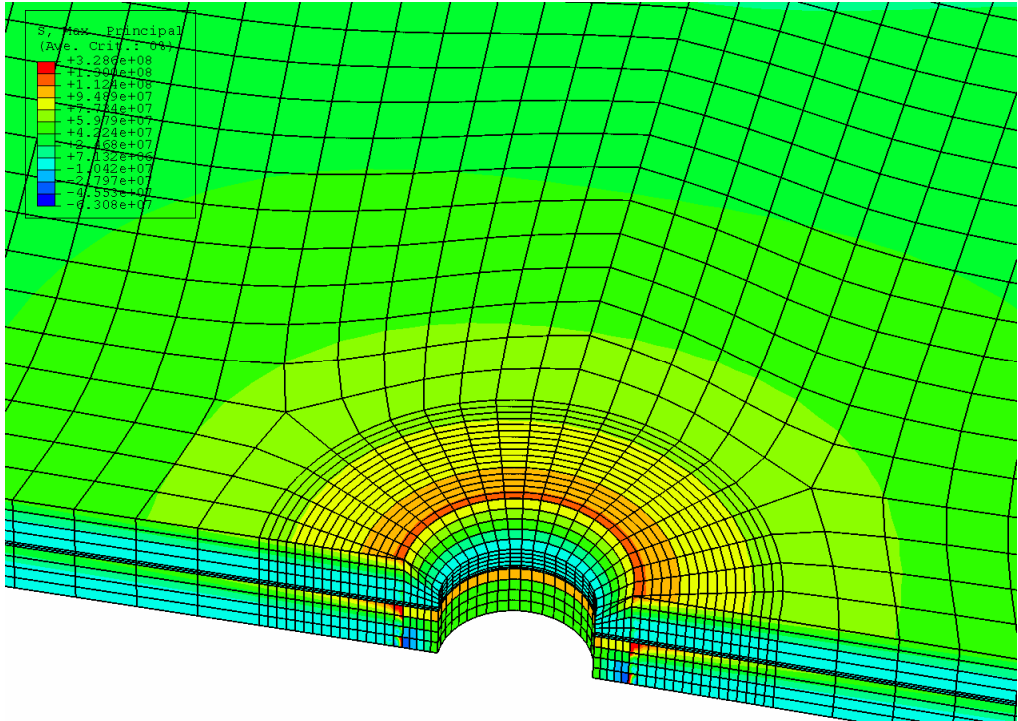

Figure 4-12 Maximum principal stress for the countersunk bolt with pressure from underneath

4.5 Bending test

4.5.1 Geometry

A 500x1300 mm glass pane was simulated to be bent as in the experimental bending test.

4.5.2 Materials

The material parameters for the bending test simulation were the same as for the compression test with the cylindrical bolt, except for the EPDM, which was modelled as a linear elastic material with the Young's modulus set to 15 MPa.

4.5.3 Modelling

Surface-to-surface contact between the glass and the bush was done in the exact same manner as for the compression test with the cylindrical bolt. To restrain the glass movement, the support holding the glass was locked in three directions (x, y, z) and the support holding the lever arm, simulated as a rigid beam, was locked in two (y, z). The glass pane could not move in its plane, only out of the plane, like when the glass pane bends down with pressure on top of the bolt. The force from the machine was simulated as an applied displacement on the bolt.

Bolt fixings in toughened glass

The modelling of the bending test is shown in Figure 4-13 and summarized in Table 4-2.

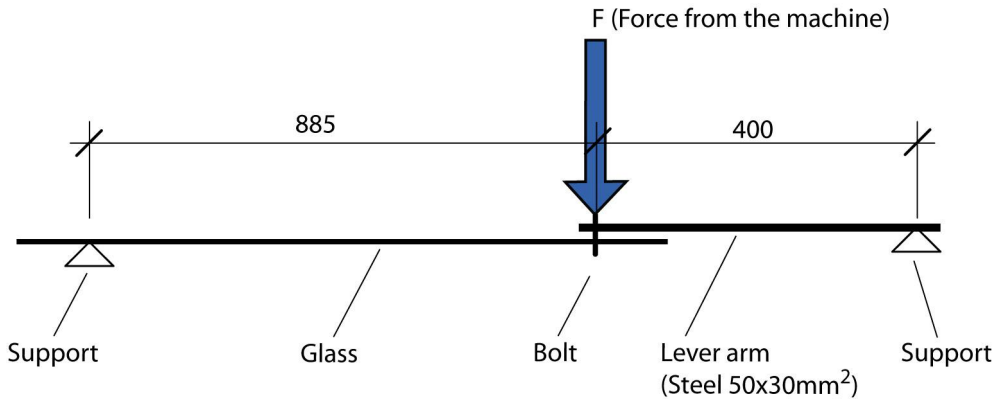

Figure 4-13 Support locked in three directions (x, y, z), glass, applied displacement on bolt acting as the force from the machine, rigid beam as the lever arm, support locked in two directions (y, z)

Table 4-2 Modelling of bending

		Bending	
Glass	6+6 mm Glass	Solid, homogeneous, deformable	
Interlayer	0.76 mm PVB		
Bolt	Steel		
Bush	EPDM (E=15 MPa)		
Interactions	Glass-EPDM <ul style="list-style-type: none"> • Surface-to-surface • Tangential behaviour • Friction formulation: Penalty • Friction coefficient: 0.19 		
Load	Line-load <ul style="list-style-type: none"> • Pressure • Static general • Uniform distribution • -80000 N/m² • 10 mm wide strip 		
Boundary conditions	Restrained bolt: Applied displacement Glass: Upper end U1=U2=U3=0 Rigid beam: Loose end U2=U3=0		
Constraints	Bolt-EPDM <ul style="list-style-type: none"> • Tie 		

4.5.4 Results

The results from the modelling are as for the compression test shown in plots obtained from the simulations in ABAQUS. There are here four plots of curves and one visual plot. One force-displacement plot and one moment-displacement plot that correspond to the experimental force- and moment-displacement diagram respectively. The third and fourth plot show stress-displacement curves, the third with the tensile stress taken from the area where the strain gauges were glued, and the fourth from the area at the edge of the hole of the lower glass right next to the PVB. The last mentioned plot may also be compared with the experimental results. The visual plot shows the location of the maximum principal stress.

Figure 4-14 shows a linear curve that almost corresponds to the curves in the force-displacement diagram in Figure 3-23 and Figure 4-15 corresponds to the results from the experimental test shown in Figure 3-24

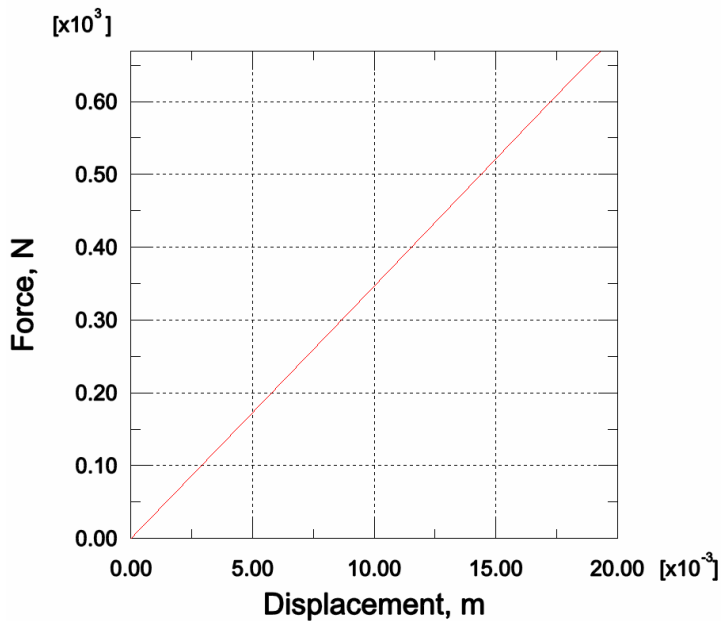

Figure 4-14 Force-displacement for the bending

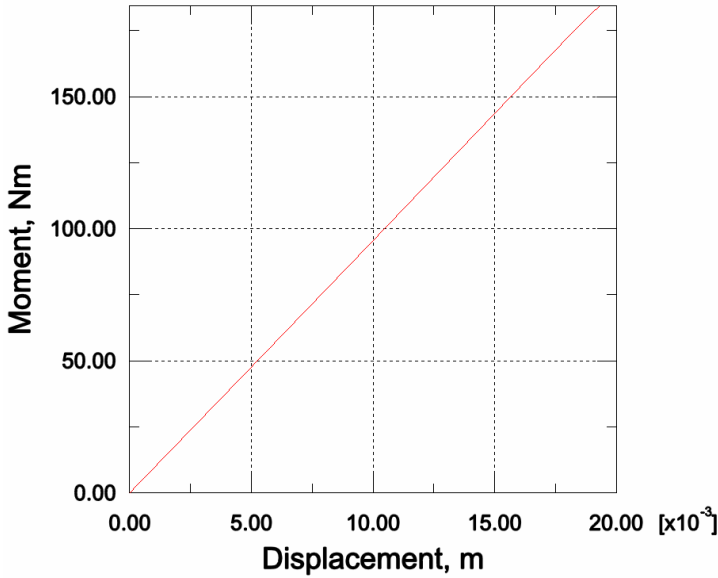

Figure 4-15 Moment-displacement

The stress-displacement plot in Figure 4-16 shows a lower displacement with the same stress compared to the curves in Figure 3-25, obtained from the experimental tests. The curve in Figure 4-17 indicates a higher stress at the same displacement compared to the curve in Figure 4-16, which means that the maximum stress is located at the edge of the hole in between the glasses. The location of the maximum principal stress is shown in Figure 4-18.

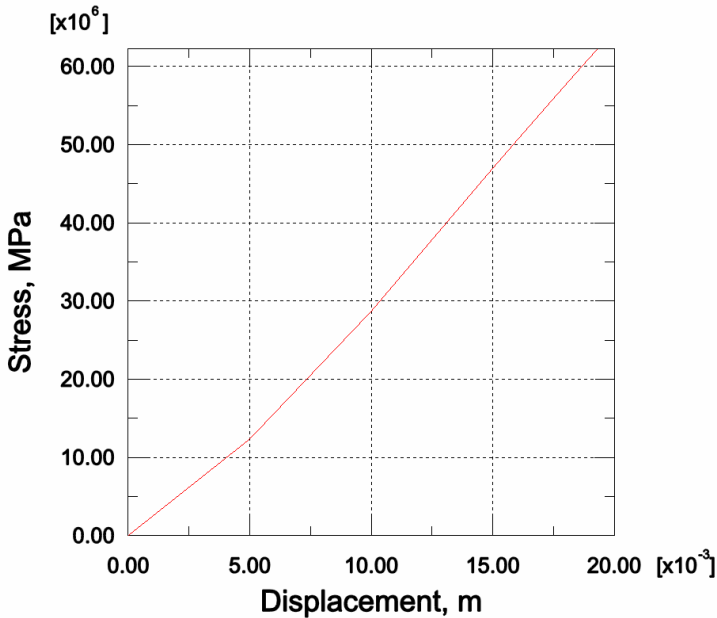

Figure 4-16 Stress-displacement for the bending

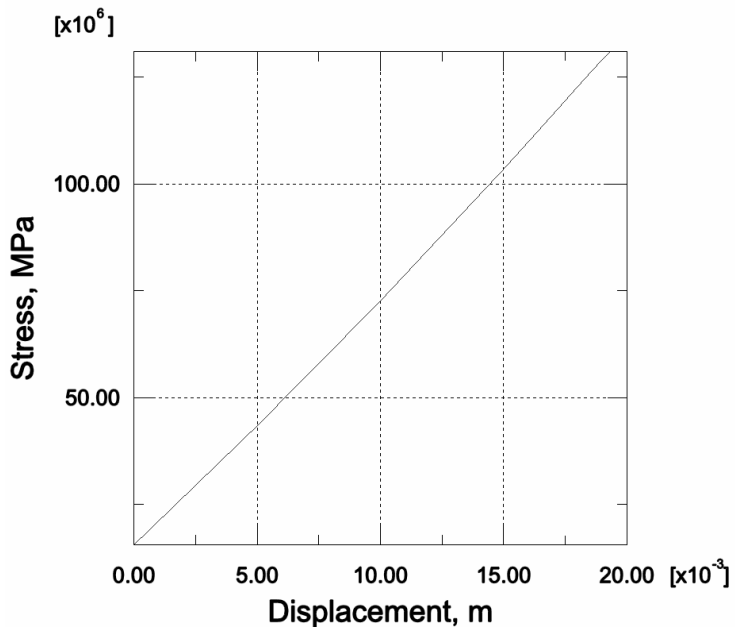

Figure 4-17 Stress-displacement for the lower glass where it interacts with the PVB

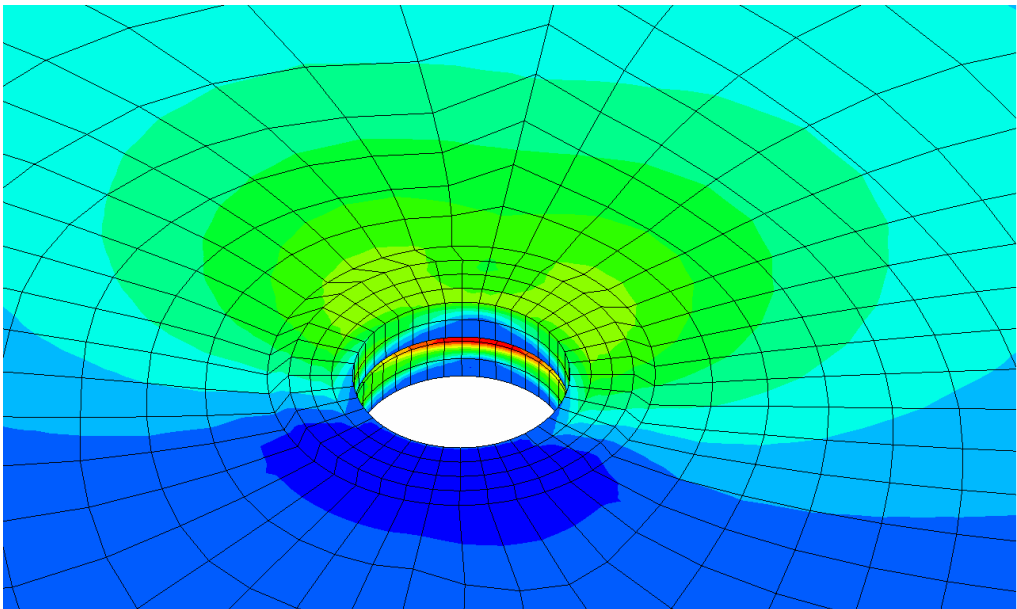

Figure 4-18 Maximum principal stress for the bending

4.6 Discussion

It is important to underline the fact that it is very hard to simulate the Griffith flaws and other defects that glass contains. The best way to receive more information of how glass reacts is further testing.

The results from the modelling showed the same tendency for all the test cases, the stress concentrations are largest in the lower glass closest to the PVB-layer. This is mainly due to the low stiffness of the PVB and its inability to transfer the stresses between the glass panes. In this case, it was not practically possible to measure the stress in that area, which can be why the experimental tests all through show a lower stress, or maybe better, the analysis show higher values of the stress. Overall and considering the difficulties modelling of glass can bring about, the results from the analysis and from the experimental tests correspond pretty well. Moreover, the numerical analyses show that it is very important to make thorough calculations of the local stresses that develop around the holes.

The results from the experimental bending test show that the maximum tensile stress was found to be located on the edge of the hole in between the glasses, where it was difficult to measure the strain. The measuring of the strain was not optimal for this testing. This analysis was therefore hard to accomplish regarding similarity with reality. The simulation of the bending test should be calibrated and changed to improve the similarity with the experimental test. The most pronounced differences between the modelling and the test was above all the size of the displacement, which was smaller in the analysis because of the difficulties to simulate the EPDM as soft as in the reality.

The deflection was large and that is a limiting factor within glass, especially when it comes to the psychological experience when the glass bends out. The experimental test clearly showed that a glass pane fixed onto the joists with only one bolt at each side do not holds the standards.

To accomplish better bearing of a full-scale balustrade, there may have to be at least four bolts (one pair of bolts over each other on each side) fixed onto the joists. A handrail is strongly recommended for stability and as an extra safety, furthermore it would help to decrease the considerable deflection.

5 Evaluation of the results from the analysis

One of the objectives with this study was to create a simple design tool in form of a tablet or a simple computer program. It was intended to be as simple as you vary some parameters, to get suitable sizes of the glass panes and distances between holes to produce creative solutions regarding glass fixings. The motive was to create fixings where the fixing details were concealed as much as possible so that the glass becomes more and more visible.

There are many factors that affect the ultimate strength of bolt-fixed glass, for instance the toughening and the grinding of the holes. These factors were not evaluated in this study and therefore, more testing has to be made in order to determine if the analyses are trustable to be used as a basis for the creation of the desired design tool. The analyses made are a very good beginning to accomplish such a thing but there has to be more work done to obtain a more accurate calibration of the model parameters. It would be very interesting to go further in this matter.

6 Future work

As a calibration and a verification of the FE-analyses of the tests, the tensions from the tests and the modelling could be compared through diagrams and tables of parameters of interest. This thesis supplies a good start.

One thing that should be done is an establishment of relations between strength and design parameters, this with help from the results of this paper and if possible some more testing. Interesting relations could for instance be between applied loads, strength, thickness, size, distances between holes and from a hole to an edge etc. It would be good if it was possible to put up some analytical relations.

Examples of important parameters for establishment of relations could be:

- Tensile stress
- Force
- Deflection
- Bending moment

- Supporting system
- Glass size
- Glass thickness
- Distances hole/hole or hole/edge (contra Emmaboda)
- Ultimate load
- Strength

References

Literature

- [1] Adamson, B., Backman, H. (1975). *Glas i hus*. Esselte Stadium AB, Lund. ISBN: 91-24-17448-3.
- [2] Boverket (2003). *Regelsamling för konstruktion – Boverkets konstruktionsregler, BKR, byggnadsverkslagen och byggnadsverksförordningen*, Elanders Gotab, Vällingby.
- [3] Button, D., Pye, B. (1993). *Glass in Building*. Butterworth Architecture, Oxford.
- [4] Carlson, P.O. (1992). *Glas – möjligheternas byggmaterial*. Statens råd för byggnadsforskning, Stockholm. ISBN: 91-540-5442-7
- [5] Carrick, C., Vasur, J. (2002). *Styvhet och hållfasthet hos laminerat glas*. TRITA-BKN. Examensarbete 174, Stålbyggnad 2002. ISSN 1103-4297. ISRN KTH/BKN/EX--174--SE.
- [6] Dutton, H., Pye, B. (1995). *Structural glass*. Chapman and Hall, London, England. ISBN: 0-419-19940-3
- [7] Emmaboda Glas AB (2005-02-04). *Hål och urtag i glas*. Hämtad den 4 februari 2005 från <http://www.emmabodaglas.se/> under länkarna Glasinformation – Bearbetning.
- [8] Josey, B. (1997). *Glass for buildings – is it crystal-clear?* Structural Survey, Volume 15, Number 1, 1997, pp. 15-20. MCB University Press. ISSN 0263-080X.
- [9] Månsson, A. (2004). *Glaskonstruktioner – starka men sköra. En studie över håltagning och infästningsdetaljer*. Examensarbete 04:17, Institutionen för konstruktion och mekanik, Stål- och träbyggnad, CTH, Göteborg.
- [10] Nijse, R (2003). *Glass in structures*. Birkhäuser, Switzerland, printed in Germany.
- [11] Ottosen, N.S., Petersson, H. (1992). *Introduction to the Finite Element Method*, Prentice Hall.
- [12] Pilkington Floatglas AB (2004). *Glasfakta 2004*.

Verbal sources

[13] Carrick, C. (2005), Monsanto Saflex ®

[14] Colvin, J (2004/2005). *Design of glass*. (word-document)

[15] Holmlund, P. (2005-09-21). *Polymerers egenskaper och användning*. (PPT)