

*Master Thesis*

# **A Lean study to improve the efficiency and flexibility of the product realisation process**

*Lucas Edwards & Erik Skanby*

---

*Division of Machine Design • Department of Design Sciences*

*Division of Production Management • Department of Industrial Management & Logistics*

*Faculty of Engineering LTH • Lund University • 2013*



**LUND UNIVERSITY**



# **A Lean study to improve the efficiency and flexibility of the product realisation process**

*Lucas Edwards & Erik Skanby*

---

*Division of Machine Design • Department of Design Sciences*

*Division of Production Management • Department of Industrial Management & Logistics*

*Faculty of Engineering LTH • Lund University • 2013*

Division of Production Management, Department of Industrial Management &  
Logistics  
Faculty of Engineering LTH, Lund University  
Ole Römers väg 1, Box 118  
SE-221 00 Lund  
Sweden

Division of Machine Design, Department of Design Sciences  
Faculty of Engineering LTH, Lund University  
P.O. Box 118  
SE-221 00 Lund  
Sweden

ISRN LUTMDN/TMKT 13/5477 SE

## **Preface**

This master's thesis has been an exciting challenge where a lot of new insights and experience has been gained. We would like to thank our supervisor at Company A, Peter Janglund, for giving us the opportunity to conduct our master's thesis internationally and for providing great tutoring and guidance. Furthermore, we also want to thank Peter Prodromos, Frank Franzoni, Kylie Lemin, Anna Nordstedt and the rest of the personnel at Company A for their time and effort.

Also, a special thanks to our supervisors Bertil, I. Nilsson and Damien Motte at the Faculty of Engineering LTH, Lund University, for always being available and providing us with their experience and expertise.

Lund, June 2013

Lucas Edwards & Erik Skanby



## **Abstract**

This thesis investigates the possible positive effects a Lean study of the, planning, production and development of products, may have on a company's product realisation process. In an environment where a company needs to satisfy a customer demand for both standard and customised products will induce a wide product range. This can induce a lot of wasteful activities and puts pressure on the product realisation process to be efficient and flexible. The purpose of the thesis was to identify gaps which need to be improved in order to increase the efficiency and flexibility of the product realisation process.

In order to study this phenomenon a company that practices both production and development of products, as well as offering both standard and customised products was chosen for a case study. The authors utilised value stream mapping, interviews and observations to establish a great understanding of the company's activities within the product realisation process. From this, the authors identified gaps that needed to be improved in order to fulfil the standards of ISO 9001 and to increase the efficiency and flexibility within the product realisation process.

The study resulted in 15 identified gaps concerning the production and product development departments. Several gaps were chosen for an in-depth study based on their feasibility and potential of improvement. The authors developed several in-depth proposals utilising the Lean philosophy as well as production and inventory control tools, and proven product design techniques. If implemented these proposals would increase the efficiency and flexibility within the product realisation process.

The authors suggest that companies should conducting a Lean study of the product realisation process with the purpose to increase the efficiency and flexibility. This will enable a company to identify and improve the proper aspects in order to survive or gain market shares in an environment where the customer demand for standard and customised products needs to be satisfied.

### **Keywords:**

Lean, Product Realisation Process, Efficiency, Flexibility, and Value Stream Mapping.





# Sammanfattning

## Introduktion

Denna avhandling är baserad på författarnas tes om möjliga positiva effekter som en Lean studie av planeringen, produktionen och utvecklingen av produkter kan ha på ett företags produktframtagningsprocess. Syftet med avhandlingen var att identifiera gap som måste förbättras för att öka effektiviteten och flexibiliteten i produktframtagningsprocessen.

Att operera på en marknad där man alltid måste uppfylla kundernas krav på både standard- och kundanpassade produkter kan vara svårt och utmanande. Att konkurrera på denna typ av marknad kräver att företaget har ett flexibelt och effektivt produktionssystem för att överleva eller vinna marknadsandelar.

Denna affärsidé kan framkalla en hel del icke-värdeskapande aktiviteter inom produktframtagningsprocessen eftersom den utsätts för en oförutsägbar kundefterfrågan. Lean-filosofin har ett starkt fokus på ständiga förbättringar för att eliminera icke-värdeskapande aktiviteter och för att förbättra produktframtagningsprocessen.

Lean-filosofin användas för att lokalisera dessa slösaktiga aktiviteter under hela produktframtagningsprocessen och ger de stödjande verktyg för att hantera dessa aktiviteter.

## Arbetssätt

För att studera fenomenet valdes ett företag för en fallstudie som producerar och utvecklar produkter, liksom tillgodoser kundernas krav på både standardanpassade och kundanpassade produkter. En referensram som passar projektets problemformulering bildades i syfte att förstå problemet och för att genomföra den empiriska fasen på ett korrekt sätt. Författarna utnyttjade value stream mapping, intervjuer och observationer för att samla in data och för att upprätta en stor förståelse för företagets verksamhet inom produktframtagningsprocessen.

Från den insamlade empiriska data etablerades ett nuvarande tillstånd av företaget som i detalj beskriver arbetsaktiviteterna inom produktframtagningsprocessen.

Analysen använde referensramen och det etablerade nuvarande tillståndet för att identifiera gap som måste förbättras inom produktframtagningsprocess. Från detta resultat valdes flera gap för fördjupande studier, där urvalet baserades på deras potential och genomförbarhet.

Grundligt undersökta förslag togs fram med syftet att öka effektiviteten och flexibiliteten i produktframtagningsprocessen.

### **Teoretisk Referensram**

Lean teori och verktyg utnyttjades under hela projektet för att identifiera gap, icke-värdeskapande aktiviteter och för att systematiskt standardisera processer.

Dessutom med syftet att standardisera processer och reducera icke-värdeskapande aktiviteter undersöktes den potentiella ”Commonality” av de tillverkade produkterna, dvs. möjligheten att ha gemensamma komponenter och delsystem inom och genom produktfamiljer. En rad modulära produktdesignsmetoder samt design för tillverkning och montering (DFMA) utnyttjades.

För att analysera produktionssystemet, utnyttjade författarna teorier om push-och pull-system samt customer order decoupling point (CODP).

Produktframtagningdelen av ISO 9001 användes för att koppla ihop produktionssystemet och produktutvecklingsprocessen.

För att minska totala ställtider, har teorin om ekonomisk orderkvantitet (EOQ) utnyttjats för att analysera möjligheterna av lagerstyrning.

För att identifiera layout och kartlägga flödet av material och information, har verktyget value stream mapping (VSM) utnyttjats.

Teorin om Deming Cycle behandlades och användes som stöd för de föreslagna implementeringarna.

### **Analys**

Från analysen identifierades 15 gap som kunde öka effektiviteten och flexibiliteten i produktframtagningsprocessen om förbättringar görs. De gap som valdes för en fördjupad studie och deras respektive potential att öka effektiviteten och flexibiliteten åskådliggörs i tabell 1 nedan.

**Tabell 1** Potentialen för respektive gap

<b>Valda förbättringsmöjligheter</b>	<b>E<sup>1</sup></b>	<b>F<sup>2</sup></b>	<b><sup>3</sup>P V</b>
Ett icke-systematiskt och ineffektivt mellanlager.	4	4	8
Ett otillräckligt flöde av information för WIP.	4,5	4,5	9
Inspektion av inkommande varor, med fokus på råmaterial.	2	3	5
Avdelningen saknar ordning, struktur och standardiserade arbetsrutiner.	3	3	6

<sup>1</sup> Effektivitet

<sup>2</sup> Flexibilitet

<sup>3</sup> Potentialt värde

Ineffektiv materialförsörjning.	4	4	8
Produktdesignen är inte helt optimerad för tillverkning och montering.	4	3	7
Graden av "commonality" i produktfamiljers design är inte optimal.	4	4	8

## Resultat

Utfallet av de utvecklade förslagen anses vara i linje med det uttalade syftet, men med varierande potential. Förslagen kommer alla att bidra till antingen en ökad effektivitet, flexibilitet eller båda eftersom arbetsmiljön kommer att nå ett större styrt tillstånd. Med ett av författarna etablerat Inbound Logistics Management System, kommer företaget att få bättre kontroll på råmaterialet när den införs i produktionssystemet eftersom varorna inspekteras. Detta system kommer att skydda mot ineffektiviteter såsom onödig förflyttning och transport, och defekter. Dessutom kommer det att möjliggöra kontinuerliga förbättringar med leverantörer på ett kontrollerat sätt, eftersom leverantörens prestanda kommer att mätas och utvärderas. I termer av flexibilitet, kommer detta också att öka då införandet av detaljerad dokumentation och standardiserade arbetsrutiner kommer möjliggöra flexibilitet av de anställda.

Författarna utvecklade ett förslag om hur man kan strukturera och standardisera mellanlagret (SFGI). Förslaget om att använda ett strukturerat mellanlager kommer ytterligare öka effektiviteten eftersom att plocka från ett strukturerat och standardiserat mellanlager blir mycket enklare när det har fastställts vilka delar hålls och var de hålls. Detta förslag avviker dock från syftet, eftersom det kommer att framkalla andra stora fördelar såsom minskade ledtider och sänkta skrotnivåer. Det kan hävdas att det kan uppstå en liten minskning av flexibilitet på grund av det faktum att större partier kommer att produceras till mellanlagret. Men fördelarna är större än nackdelarna. Dessutom kommer det att finnas några effektivitetsfördelar av att minska det totala antalet ställ i produktionen. Dessutom kommer införandet av ett mellanlager generera en tredje CODP på företaget som är assemble-to-order (ATO). Företaget skulle efter detta ha en mix av make-to-order (MTO), engineer-to-order (ETO) och ATO som anses vara en bättre strategi för deras marknad och kundernas efterfrågan.

Att öka informationsflödet genom att införa ett streckodsmärkningssystem där etiketterna flyttas med materialet kommer att skapa en situation där monteringsfunktionen kommer att skörda de största fördelarna. Det föreslagna systemet kommer att inducera en mindre ökning av arbetsbelastningen i tillverkningsenheten eftersom de kommer att skapa informationsflödet.

De främsta fördelarna med förslaget kommer att komma från en ökad plockeffektivitet, minskning av felaktigt kittade ordrar och minskning av stillestånd i monteringslinjerna eftersom material- och informationsflöde kommer samverka korrekt. Detta kommer möjliggöra minskade ställtider och därmed öka flexibiliteten inom monteringsfunktionen. Vidare kommer företaget att få nytta av flexibilitet av

anställda eftersom informationsflödet baseras på nummerkodning, så att vem som helst kan identifiera produktdelar utan produktkunskap. Dessa förbättringar är i linje med uppsatsens syfte eftersom både flexibiliteten och effektiviteten kommer att höjas i produktframtagningsprocessen.

Ett 5S-system har också föreslagits och stödjande verktyg har utvecklats. Företaget kommer att skörda fler fördelar än bara ökad effektivitet från detta. Det kommer att lägga en plattform som möjliggör kulturell förändring inom tillverkningsenheten samt en mer kontrollerad och trivsamt arbetsmiljö. Men en kulturell förändring tar tid och företaget kommer sannolikt se effektivitetsförbättringar först på grund av en bättre organisation av element som används för att värdeskapande aktiviteter.

Implementeringen av DFMA-metodiken på företagets produkter kommer att öka effektiviteten av produktframtagningsprocessen. Genom att anpassa produktens design för att passa de tillverkningsprocesser som anses fördelaktiga av företaget kommer flaskhalsar att elimineras, materialkostnader sänkas och produktionstider reduceras. Genom att förbättra monteringsbarheten kommer, förutom ökad effektivitet, också moralen i monteringen förbättras eftersom produkterna blir enklare och snabbare att montera.

Genom att öka graden av "Commonality" på företagets produktfamiljer kommer effektiviteten i produktutvecklingsavdelningen att öka. Detta eftersom användandet av unika komponenter inom alla produktfamiljer kommer att minska vilket innebär att antalet komponenter som måste hanteras när produktfamiljer ska uppdateras till nya generationer minskar. Att minska antalet unika komponenter kommer också att öka effektiviteten i företagets databassystem. En ökning av "Commonality" kommer också att öka flexibiliteten i produktionssystemet eftersom fler av samma komponenter används över ett bredare produktsortiment och differentieringen av produkten flyttas längre ned i tillverkningsprocessen. Detta kommer att möjliggöra för ordrar att ändras så långt ner som i den sista produktionsprocessen.

# Table of Contents

<b>1 Context and Introduction .....</b>	<b>1</b>
1.1 Introduction .....	1
1.2 Company Presentation.....	1
1.3 Problem .....	2
1.4 Purpose .....	2
1.5 Strategy .....	2
1.6 Theories, Methods & Tools .....	4
1.7 Delimitations.....	5
1.8 Deliverables .....	5
<b>2 Methodology .....</b>	<b>7</b>
2.1 Research Purpose .....	7
2.1.1 Research Purpose Chosen for the Project.....	7
2.2 Argumentation Techniques .....	8
2.2.1 Deductive.....	8
2.2.2 Inductive.....	8
2.2.3 Grounded Theory.....	8
2.2.4 Triangulation .....	8
2.2.5 Argumentation Techniques Chosen for the Project.....	9
2.3 Research methods .....	9
2.3.1 Case Studies.....	9
2.3.2 Action Research.....	9
2.3.3 Research Methods Chosen for the Project .....	10
2.4 Techniques for Gathering Data.....	10
2.4.1 Interviews.....	10
2.4.2 Observations.....	11
2.4.3 Literature Review .....	11
2.4.4 Data Gathering Techniques Chosen for the Project.....	11
2.5 Information Sources .....	11
2.5.1 Information Sources Chosen for the Project .....	12
2.6 Qualitative and Quantitative Studies.....	12
2.6.1 Quantitative.....	12
2.6.2 Qualitative.....	13

2.6.1 Approach Chosen for the Project .....	14
2.7 Credibility.....	14
2.7.1 Objectivity .....	14
How will Objectivity be Guaranteed? .....	14
2.7.2 Reliability.....	14
How will Reliability be Guaranteed?.....	14
2.7.3 Validity .....	15
How will Validity be Guaranteed? .....	15
2.8 The Relationship between Strategy and Methodology .....	15
<b>3 Frame of Reference .....</b>	<b>17</b>
3.1 Product Realisation .....	17
3.2 The Production System.....	21
3.2.1 Process Choice.....	21
3.2.2 Push and Pull.....	23
3.3 Product Development.....	25
3.3.1 Stage-Gate Process Model.....	25
3.3.2 Design for Manufacturing and Assembly .....	26
3.3.3 Modularity .....	27
3.3.4 Standardisation.....	31
3.3.5 Relationships within Modularity, and between Modularity and Standardisation .....	32
3.4 The Lean Concept.....	33
3.4.1 Lean According to Liker .....	33
3.4.2 The Five Whys.....	37
3.4.3 Waste.....	38
3.5 Tools.....	40
3.5.1 The Deming Cycle – Plan-Do-Check-Act.....	40
3.5.2 Single Minute Exchange of Die (SMED) .....	40
3.5.3 Economic Order Quantity (EOQ) .....	42
3.5.4 Kanban.....	43
3.5.5 5S .....	44
3.5.6 Value Stream Mapping .....	45
3.5.7 Evaluation Tools – Design for Assembly Method.....	49
<b>4 The Current State at Company A.....</b>	<b>53</b>
4.1 Market Overview .....	53
4.2 Production System .....	54
4.2.1 Manufacturing .....	55

4.2.2 The Assembly Function.....	61
4.3 Product Development.....	65
4.3.1 Stage gate model.....	65
4.3.2 Design for manufacturing and assembly.....	66
4.3.3 Standardisation.....	67
4.3.4 Modularity.....	67
4.3.5 Evaluation.....	69
<b>5 The Current State Analysis.....</b>	<b>71</b>
5.1 Production System.....	71
5.1.1 Manufacturing.....	72
5.1.2 The Assembly Function.....	76
5.2 Product Development.....	78
5.2.1 Stage Gate Model.....	78
5.2.2 Design for Manufacturing and Assembly.....	78
5.2.3 Standardisation.....	79
5.2.4 Modularity.....	79
5.2.5 Evaluation.....	80
5.3 Product Realisation Process.....	81
<b>6 Summary and Selection of the Identified Gaps for Further Work.....</b>	<b>85</b>
<b>7 Future State Analysis.....</b>	<b>93</b>
7.1 Inspection of Incoming Goods, Focusing on Raw Material.....	93
7.2 An Un-systematic and Inefficient SFGI.....	96
7.3 An Insufficient Flow of Information for WIP Causing an Inefficient Material Supply.....	102
7.4 Department Lack Orderliness, Structure and Standard Work Procedures.....	114
7.5 Product Designs are not Fully Optimised for Manufacturing and Assembly.....	119
7.6 Increase the Level of Commonality in Product Design.....	133
<b>8 Conclusions and Project Evaluation.....</b>	<b>141</b>
8.1 Project Results.....	141
8.2 Future Studies.....	143
8.3 The Authors Contribution to Lean studies.....	144
8.4 Project Reflection.....	144
<b>References.....</b>	<b>147</b>
<b>Appendix A : Delivery Discrepancy Form.....</b>	<b>1</b>
<b>Appendix B : Detailed Inspection Documentation.....</b>	<b>2</b>

<b>Appendix C : Supplier Evaluation Tool .....</b>	<b>4</b>
<b>Appendix D : 5S .....</b>	<b>6</b>
<b>Appendix E : 5S Audit Form .....</b>	<b>9</b>
<b>Appendix F : 5S Activity Board .....</b>	<b>11</b>
<b>Appendix G : Icon List VSM .....</b>	<b>13</b>
<b>Appendix H : VSM 1 .....</b>	<b>15</b>
<b>Appendix I : VSM 2 .....</b>	<b>21</b>
<b>Appendix J : EOQ Calculations Data .....</b>	<b>25</b>
<b>Appendix K : Sensitivity Analysis of Various Holding Costs .....</b>	<b>26</b>
<b>Appendix L : EOQ Data. ....</b>	<b>27</b>
<b>Appendix M : Time Plan of the Project.....</b>	<b>29</b>
<b>Appendix N: DFMA Worksheet.....</b>	<b>31</b>
<b>Appendix O: Classification System Calculation Sheets .....</b>	<b>33</b>
<b>Appendix P: Additional Images of Design Changes .....</b>	<b>36</b>
<b>Appendix Q: Updated DFMA Worksheet &amp; Design Changes.....</b>	<b>39</b>
<b>Appendix R: Commonality Calculation Sheet .....</b>	<b>41</b>
<b>Appendix S: Component Structure Tree.....</b>	<b>44</b>
<b>Appendix T: Exploded Views of Product Family J's Product.....</b>	<b>46</b>
<b>Appendix U: Commonality Index.....</b>	<b>48</b>
<b>Appendix V: Additional Images of Design Changes Made to Product Family J.....</b>	<b>51</b>
<b>Appendix W: Updated Commonality Calculation Sheet .....</b>	<b>52</b>



## Abbreviations

ATO	Assemble-To-Order
BOM	Bill Of Materials
CODP	Customer Order Decoupling Point
DCI	Degree of Commonality Index
DFMA	Design For Manufacturing and Assembly
EOQ	Economic Order Quantity
ETO	Engineer-To-Order
ILMS	Inbound Logistics Management System
MTO	Make-To-Order
MTS	Make-To-Stock
PDCA	Plan Do Check Act
PRP	Product Realisation Process
SMED	Singel Minute Exchange of Die
TPS	Toyota Production System
VSM	Value Stream Mapping
WIP	Work In Process



# 1 Context and Introduction

*The reader will be introduced to the studied problem and purpose of the thesis in this chapter. A brief company presentation will be provided as well as a description of the strategy for the project, delimitations and utilised theories, methods and tools.*

## 1.1 Introduction

Being on a market that requires a business to always meet their customers' demands on both standard and customised products can be difficult and challenging. Competing on this type of market requires a business to have a flexible and efficient production system in order to survive or gain market shares.

One of the main challenges is how the business handles their strategy of customer order decoupling points (CODP) in order to satisfy the demand in an efficient manner. The CODP's function is to separate decisions made under certainty from decisions made under uncertainty in regards to customer demand. A business's chosen strategy will affect how the production is managed and a misalignment can induce an inefficient and inflexible production system.

Businesses that can successfully satisfy the demand of both standard and customised products have to provide a wide and flexible product range. This can be very costly if the product designs are not thoroughly considered. Utilising product design strategies can provide a platform for successfully designed & engineered products.

This business mission can induce a lot of wasteful activities within the product realisation process since it is subject to an unpredictable customer demand. The Lean philosophy has a strong focus on continuous improvement in order to eliminate wasteful activities and improve the product realisation process.

The Lean philosophy can be utilised to locate these wasteful activities throughout the product realisation process and provides the supporting tools to handle these activities.

## 1.2 Company Presentation

A case will be studied, related to the below defined problem. The case company, Company A, a member of the Company B Group, is an international company who manufacture luminaries as well as provide premier lighting solutions to its customers throughout Australia. Company A has its Head Office and manufacturing site in Melbourne, with sales & support offices in Sydney, Brisbane and Adelaide. Company

A is involved in numerous projects providing lighting solutions for building complexes such as hospitals, gallerias, car parks and offices.

Company A has sister companies within the Company B Group, with similar product range and their own production facilities, which can be used by Company A too.

### **1.3 Problem**

Being a company that is driven to always meet their customer's demands and the nature of the market can affect the product realisation process. These companies need both efficiency and flexibility in their product realization process as well as in the product designs. There is no financial space for waste or similar phenomena.

This is the existing situation at Company A which has led to a yearly trend of reduced batch sizes, an increased product range demand, and production of customised orders. This puts pressure on the production system to be efficient and flexible.

Company A's strategy to always meet their customer's functional demands or customised requirements induces high pressure on the product development function, dealing with both customised orders, and development of new products to meet the market's needs. With scarce resources and the mentioned situation, there is a need for supporting development tools and concurrent engineering, in order to sustain and further develop an efficient and flexible production realisation process.

Company A is a fast growing company, and if the product realisation process is not adaptable for the growth in demand, problems will soon affect their service levels. It is therefore crucial to locate and assess these problems in order to maintain a good service level in the future.

### **1.4 Purpose**

The purpose of the thesis is to conduct a Lean study to identify opportunities of improvement and develop in-depth proposals in order to increase the efficiency and flexibility within the product realisation process.

Product realisation is the demand fulfilment process in a business and is a term best described as the work an organisation has to conduct in order to engineer, design, manufacture and supply a product.

To make this project close to reality and to be able to test the framework, a single case study is performed at Company A

### **1.5 Strategy**

To successfully achieve the above stated purpose a thorough analysis of the product realisation process has to be carried out, as well as understanding the market needs. The authors also need to gain an understanding of the manufactured products to be able to optimise the product realisation process in an effective way.

Illustrated in figure 1.1 is the work process for the project. The thesis should be completed within 20 weeks, with 18 weeks on site at Company A. The authors have developed a project specification with a broader scope before arriving to Company A,

a pre-study needs to be executed in order to refine the specifications of the project to better fit the company and the students requirements. The pre-study should also serve the purpose of providing an understanding of the internal value chain. A review of research methodologies is conducted and the proper methodology for the project is chosen.

A literature review will be carried out in order to collect the proper data to support the current state analysis. When the current state analysis is completed, the authors will conduct a future state analysis. If the authors find gaps of interest that need additional literature review to support their arguments or understanding, an iterative process will be followed, shown in figure 1.1. Presented in appendix M is the time plan established before the project start compared to the actual time plan of the project. The work distribution among the authors is also presented here.

The current state assessment of the production and product development system will be done in the following steps by conducting value stream mapping, interviews and observations.

For the production system:

- Identifying the existing processes
- Identifying the layout
- Mapping the value stream

For the product development system:

- Identifying the product architecture
- Identifying development procedures
- Identifying the design methods

After completing the assessment of the current state, an analysis on how the current state correlates with existing theories will be conducted in order to identify opportunities of improvements. The identified opportunities of improvements will be evaluated based on their highest potential of improving efficiency and flexibility. The authors will chose to proceed with the opportunities with highest potential but will also consider their feasibility based on the scope of the project.

An in-depth study will be carried out on the opportunities of improvements, also called gaps, identified with the attempt to find solutions that will correspond with the purpose of the project. This will form the future state analysis.

After completing the analysis of the production system and the product development system, a proposal of possible improvements and how these can be implemented will be created.

Finally the authors will reflect on the project and discuss the outcome of the analysis.

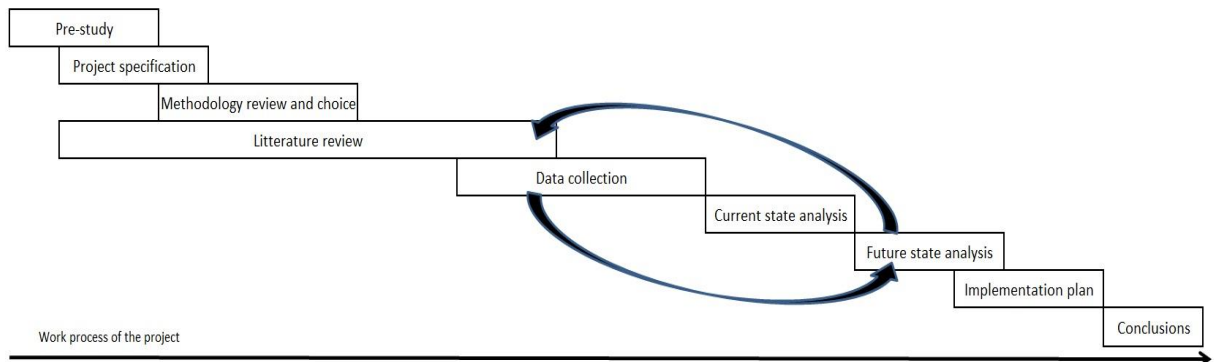

**Figure 1.1** Work process of the project

## 1.6 Theories, Methods & Tools

In order to be successful in our methodology certain existing theories, methods and tools must be considered. The theory and tools of Lean production will be considered throughout the methodology to identify opportunities of improvements, non-value adding activities and to systematically standardise processes.

Furthermore, in order to achieve a robust system, standardise processes and reduce non-value adding activities the potential commonality of the manufactured products must be considered. A range of modular product design techniques will be used as well as design for manufacturing and assembly (DFMA).

For the analysis of the production system, the authors will consider theories on push and pull systems as well as Customer Order Decoupling Point (CODP).

The product realisation part of ISO 9001 will be considered in order to connect the production system and product development processes.

To reduce total set-up times, the theory on economic order quantity (EOQ) will provide the framework in order to analyse the possibility of inventory control. The theory of single minute exchange of die (SMED) will be utilised when analysing the possibility of reducing setup times.

To identify the layout and map the flow of material and information, the tool value stream mapping (VSM) will be utilised. VSM will visualise waste and opportunities of improvements.

The theory of the Deming cycle will be used when considering how possible improvements can be implemented.

To summarise, listed below are the mentioned theories, methods and tools:

- Lean production tools
- Product design techniques – DFMA, Commonality
- VSM – Value stream mapping
- ISO 9001 – Product realisation
- The Deming cycle

- SMED
- EOQ
- Push and Pull
- CODP

### **1.7 Delimitations**

For the projects feasibility some delimitations are necessary.

With Company A's wide product range the analysis of the production system will be done for a couple of the product families. This will still enable the thesis to investigate the difference in results between product families.

The project will consider the flow, from order to finished goods inventory.

### **1.8 Deliverables**

The deliverables of the thesis are:

- A Lean framework for this type of industries
- An analysis of the current production system
- An analysis of the product development system
- Identified opportunities of improvement
- A proposal of improvements and how they could be implemented.

Physical deliverables:

- A report in English
- Scientific article
- Seminars





## 2 Methodology

*In this chapter the authors have provided the reader with a review of the chosen methodology in order to study the thesis' problem and why the specific methodology was chosen. The authors will present the chosen research purpose which will lead to the research strategy and methods that was deemed most suitable for the project. Following this is the techniques data can be collected and obtained through and what type of data these will produce. Also, to assure that the authors understand how credibility is ensured, a review of corresponding literature has been conducted. Finally the authors have connected the chosen methodology with the project strategy.*

### 2.1 Research Purpose

Different research methods serve different purposes. What method that should be chosen depends on the project's goal and characteristics.<sup>4</sup> The research can be broken down into four purpose classifications:

- *Exploratory*– finding out what is happening, seeking new insights and generating ideas and hypotheses for new research.
- *Descriptive* – portraying a situation or phenomenon.
- *Explanatory* – seeking an explanation of a situation or a problem, mostly but not necessary in the form of a causal relationship.
- *Improving* - trying to improve a certain aspect of the studied phenomenon.<sup>5</sup>

The most common research purpose utilised at Technology Institutes is the improving approach. When conducting such a research purpose, there are often elements of other purposes as well. For example, a problem could be identified applying the exploratory purpose in a sub-study, later applying the improving purpose in a sub-study of the identified problem.<sup>6</sup>

#### 2.1.1 Research Purpose Chosen for the Project

The project offers a high degree of freedom of what issues to identify and solve. Because of this, the authors have chosen to initially conduct a sub-study with an exploratory and descriptive purpose. The findings, ideas, and insights gathered will

---

<sup>4</sup> Höst et al., p. 29, 2006

<sup>5</sup> Runeson, Höst., p. 135, 2008

<sup>6</sup> Höst et al., p. 29, 2006

set the foundation for the next sub-study. This sub-study will be executed with an improving purpose, focusing on the issues with the highest potential of improvement.

## 2.2 Argumentation Techniques

Argumentation techniques correspond to different strategies in how research can be conducted.

### 2.2.1 *Deductive*

*Deductive* theory represents the most common view of the nature of the relationship between theory and social research. The researcher deduces a hypothesis from the basis of what is known of in a particular domain with theoretical consideration in relation to that same domain. This hypothesis must then be empirically analysed and concepts will have to be translated into researchable entities. The theory and hypothesis drives the process of gathering data. The data is evaluated and then fed back into the theory, which can be seen as inductive, and the hypothesis is confirmed or rejected and the theory revised.<sup>7</sup> The deductive strategy can be best associated with a quantitative research approach.

### 2.2.2 *Inductive*

*Inductive* theory is the opposite of deductive: Theory is the outcome of research. In other words, generalisable assumptions are drawn out of observations. But, just as some induction can be seen in the deductive process, some deduction can be seen in the inductive process. Once the findings have been manifested into a theory, the researcher may want to collect further data in order to know when the theory may and may not hold.<sup>8</sup> The inductive strategy is closest associated with a qualitative research approach.

### 2.2.3 *Grounded Theory*

This type of technique is very common for researchers conducting small-scale projects using qualitative data and by those who has an exploratory focus study. Theories generated from a grounded theory approach should be based on empirical research with emphasis on fieldwork as the fundamental part of the work of the researchers. This should be carried out throughout the course of the research, not only at the starting point, gradually building up the theory.<sup>9</sup>

Grounded theory should generate theories that are useful at a practical level and meaningful to those 'on the ground'.<sup>10</sup>

### 2.2.4 *Triangulation*

*Triangulation* involves locating a true position by referring to two or more other coordinates. This is done to add validity to the collected data by seeing things from different perspectives. It doesn't necessarily prove that the researcher is right, but it

---

<sup>7</sup> Bryman, pp. 24-25, 2012

<sup>8</sup> Ibid, p. 26

<sup>9</sup> Denscombe, p. 110, 2003

<sup>10</sup> Ibid, p. 112

does give some confidence that the meaning of the data has some consistency across the methods.<sup>11</sup> By using different methods of data collection for the same topic the researcher can get an angle on the topic and be more able to know where the ‘truth’ lies. One should know that triangulation is not an exact method to finding the ‘truth’ but should rather be used to see if different methods point in a similar direction.<sup>12</sup>

### *2.2.5 Argumentation Techniques Chosen for the Project*

During the project both an inductive and deductive approach will be applied. The inductive approach will be utilised during the pre-study of Company A and if iteration should occur during the work process of the project, shown in figure 1.1. The deductive approach will be applied throughout the remainder of the project starting with the literature review. Due to the characteristics of the project, the grounded theory approach will be utilised. In order to get closer to where the ‘truth’ lies and see issues from different perspectives, triangulation approach will be conducted by using several sources of information.

## **2.3 Research methods**

### *2.3.1 Case Studies*

Case studies are very popular to use when it comes to small-scale research studies.<sup>13</sup> Case studies can be conducted if one wants to study a social group, community, system, organisation, institution, event, or even a person.<sup>14</sup> A case study usually emphasises depth rather than breadth and the particular rather than the general.<sup>15</sup> Intensive investigations are performed into one or a few of the cases to see how well theory can be generated and tested. This can be done with both inductive and deductive reasoning.<sup>16</sup>

### *2.3.2 Action Research*

Action research is related in some ways to experimental, although it is conducted in the real world rather than a controlled environment.<sup>17</sup> It is usually associated with ‘hands-on’ research projects<sup>18</sup> with procedures done essentially ‘on the spot’.<sup>19</sup> No attempts are made to isolate features of the problem from its natural environment in order to study it. It is mainly based on observational and behavioural data.<sup>20</sup> Action research is defined by four characteristics:

- *Practical.* It is aimed at dealing with real-world problems and issues, typically at work and in organisational settings.

---

<sup>11</sup> Denscombe, p. 133, 2003

<sup>12</sup> Denscombe, p. 134, 2003

<sup>13</sup> Runeson et al., p. 137, 2006

<sup>14</sup> Walliman, p. 45, 2006

<sup>15</sup> Denscombe, p. 32, 2003

<sup>16</sup> Walliman, pp. 45-46, 2006

<sup>17</sup> Ibid, p. 41, 2006

<sup>18</sup> Denscombe, p. 73, 2003

<sup>19</sup> Walliman, p. 41, 2006

<sup>20</sup> Ibid, p. 42

- *Change*. Both as a way of dealing with practical problems and as a means of discovering more about the phenomena. Change is regarded as an integral part of research.
- *Cyclical process*. Research involves a feedback loop in which initial findings generate possibilities for change, which are then implemented and evaluated as a prelude to further investigation.
- *Participation*. Practitioners are the crucial people in the research process. Their participation is active, not passive.<sup>21</sup>

### 2.3.3 Research Methods Chosen for the Project

The methods the authors have chosen to work with for this project are case studies and action research. Case studies due to the fact that the project is a small-scale research focusing on the particular. The action research method fits the authors well due to the nature of a ‘hands on’ and on site project, focusing on the natural environment in order to study it. Also, the aim of the project is to focus on real-world issues solving them with an iterative process, which are characteristics of the action research method.

## 2.4 Techniques for Gathering Data

A brief description of common techniques for gathering data will be discussed in this section.

### 2.4.1 Interviews

This technique is attractive to project researchers since it does not involve technical paraphernalia in order to obtain data. The researcher relies on skills he or she already have, in order to conduct a conversation. However, in reality, it is not that simple. Interviews rely on assumptions and understandings about the topic discussed this is not normally the case in a casual conversation.<sup>22</sup>

There are three types of research interviews:

- Structured interviews
  - A structured interview is similar to a questionnaire. The researcher has tight control and predetermined list of questions. Each respondent is faced with identical questions and the researcher has the advantage of standardisation. The structured interview in this sense will produce quantitative data.<sup>23</sup>
- Semi-structured interviews
  - Semi-structured interviews are more flexible in comparison to a structured interview. The researcher will have questions prepared but is flexible in term of the order of the topics discussed. Emphasis is on the interviewee to elaborate points of interest, speak more widely on topics raised and develop ideas.<sup>24</sup>

---

<sup>21</sup>Denscombe, p. 74, 2003

<sup>22</sup> Denscombe, p. 163, 2003

<sup>23</sup> Ibid, p. 166

<sup>24</sup> Ibid, p. 167

- Unstructured interviews
  - Main focus is the interviewee's thoughts. The researcher's role is to get the ball rolling on a certain topic or issue and let the interviewee develop thoughts and ideas. In reality, interviews often swing back and forth between a semi- and unstructured interview.<sup>25</sup>

#### **2.4.2 Observations**

Instead of relying on secondary data the researcher can use the data collection technique observation, this in order to obtain primary data. There are two main observation techniques, systematic observation and participant observation. Systematic observation particularly studies the interactions of an event while participant observation is used by researchers in order to have a role in the event. The latter usually produces qualitative data.<sup>26</sup>

#### **2.4.3 Literature Review**

Literature review is important in order to acquire an understanding of the topic studied, and of what has already been done on the topic. It is a way of showing that the researcher has understood previous research on the topic and the main theories in the subject area. It is a good way of summarising previous information and helps the researcher in the future course of action. In addition to this, the researcher must produce a theoretical structure that can explain facts and the relationships between them.<sup>27</sup> This has been done in section 3 where a frame of reference has been established, both for general concepts and philosophies, section 3.1, 3.2, 3.3 and 3.4 and for tools utilised to analyse certain phenomena, section 3.5.

#### **2.4.4 Data Gathering Techniques Chosen for the Project**

A literature review will be performed in order to have a frame of reference that will support the arguments and solutions the authors make, and to show that the authors understand the studied topic. The authors will utilise both interviews and observations to conduct our research in this project in order to obtain more credible data. During the interviews, the authors will use semi-structured and unstructured interviews since this will enable us to gain a greater understanding of topics raised as well as issues and ideas discussed. Since the study is conducted on site, observations are a good technique to gather primary data. Both systematic and participant observations will be applied.

### **2.5 Information Sources**

Because the nature of the data has implications for the reliability and for the sort of analysis to which the data can be subjected, it is important to be able to distinguish between different kinds of data.<sup>28</sup> Data categories can be divided into three different types:<sup>29</sup>

---

<sup>25</sup> Denscombe, p. 167, 2003

<sup>26</sup> Denscombe p. 192, 2003

<sup>27</sup> Bell, pp. 99-100, 2005

<sup>28</sup> Walliman, p. 51, 2006

<sup>29</sup> Runeson et al., p. 144, 2008

- First degree: First degree, or primary data, is present all around us. It is what our senses deal with all the time and is the closest you can get to the truth about things and events. First degree data can be done through observation, participation, measurement, and interview.<sup>30</sup> First degree methods are usually more expensive to apply than second and third since they require considerably more effort from the researcher and the subject.<sup>31</sup>
- Second degree: Second degree data is data that has been interpreted or recorded and where the researcher doesn't interact with the subject during the data collection. The quality of the data depends on the source and the methods of presentation. It is therefore always important to make an assessment of the quality of the information or opinions provided.<sup>32</sup>
- Third degree: Third degree data refers to independent analysis of work artefacts where already available and sometimes compiled data is used. Third degree methods are often less expensive, but the seldom offer the same control to the researcher. The researcher should also keep in mind that the data being used was collected and recorded for another purpose than that of the research study.<sup>33</sup>

### *2.5.1 Information Sources Chosen for the Project*

The authors will use all the data categories for this project. Primary data will be gathered through observations, participation and interviews. Secondary data would include documentation and information that the authors will received from Company A. Third degree data will consist of the literature that the authors will use throughout the project. The purpose to use all data categories is to gain a thorough understanding of different aspects throughout the project.

## **2.6 Qualitative and Quantitative Studies**

### *2.6.1 Quantitative*

Quantitative research tends to be associated with numbers as the unit of analysis. However, one must bear in mind that the distinction between quantitative and its opposite, qualitative, is oversimplified in theory compared to the real world. Also, one must understand that the sources of information do not need to differ between quantitative and qualitative approaches.<sup>34</sup>

Since quantitative research is associated with numbers, it is an approach that is well suited for an analysis that focuses on comparison and correlation of results. This approach is also well suited for large scale studies such as statistical research enabling

---

<sup>30</sup> Walliman, p. 51-52, 2006

<sup>31</sup> Runeson et al., p. 144, 2008

<sup>32</sup> Walliman, p. 53, 2006

<sup>33</sup> Runeson et al., p. 145, 2008

<sup>34</sup> Denscombe, pp. 232-233, 2003

the researcher to use data to calculate values such as mean, standard deviations, probability etc.<sup>35</sup>

When applying quantitative research in a study, the trend is a more specific focus comparing specific factors to other specific factors. The researcher should produce objective data in a quantitative research resulting in researcher detachment.<sup>36</sup>

In a quantitative analysis there are some important advantages such as; scientific respectability due to the appearance of objectivity, large amounts of data can be processed and analysed relatively quickly, interpretations and findings are based on measurements rather than impressions, and data is easier transformed into visual communication such as graphs, charts and tables. However, there are situations where quantitative analysis is disadvantageous such as; in a situation when bad methods are used to obtain the data, when the amount of data and complexity overloads the researcher and the issue of the researcher getting too involved in techniques of analysis hence not focusing on the real purpose of the research.<sup>37</sup>

### *2.6.2 Qualitative*

Qualitative research tends to be associated with words as the unit of analysis. Even though the source could be the same as for quantitative research the purpose of qualitative research is to transform information from observations, reports and recordings into data in the form of written words, not numbers. Qualitative researchers need to, in detail, describe the data in words, with sufficient details and information, in order for the reader to judge for himself or herself if the researchers interpretations of the phenomenon is justifiable and relevant for other circumstances.<sup>38</sup>

A holistic perspective is often associated with qualitative research, focusing on how things are related and interdependent.<sup>39</sup> Constant interplay between data collection and analysis is a common characteristic of qualitative research. This results in a gradual growth of understanding throughout the process.<sup>40</sup>

Qualitative research generates descriptions and theories that are grounded in reality, avoiding issues such as ‘armchair theorizing’ and ‘ideas plucked out of thin air’. Adding to the strengths of qualitative research is the in-depth study of small-scale research which tends to deal with complex social situations in a good way, providing a holistic view of the research.<sup>41</sup>

A disadvantage with the qualitative research approach is the fact that, the researcher has a closer proximity to the source, which could lead to subjective interpretation of the data analysed. Also, the data may be less representative and difficult to generalise.<sup>42</sup>

---

<sup>35</sup> Denscombe, pp. 233, 252, 256, 258, 2003

<sup>36</sup> Ibid, pp. 233-234

<sup>37</sup> Ibid, p. 264

<sup>38</sup> Ibid, pp. 232-233

<sup>39</sup> Ibid, pp. 233-234

<sup>40</sup> Walliman, p. 129, 2006

<sup>41</sup> Denscombe, p. 280, 2003

<sup>42</sup> Ibid, p. 281

### *2.6.1 Approach Chosen for the Project*

In this project the authors will use both quantitative and qualitative studies. However, there will be a dominant focus on the qualitative study. This since a qualitative study complies well with the project characteristics, such as an in-depth study in small-scale research and that solutions will be grounded in reality. Quantitative studies will be applied in order to measure the current state, and to possibly validate results.

## **2.7 Credibility**

In order for the research to be considered credible, the methods and conclusions need to be justifiable. This must be done by demonstrating to the reader the nature of the decisions taken during the research and the grounds on which the decisions can be seen as 'reasonable'. In order for a study to be credible it needs to be reliable, valid and conducted in an objective manner.<sup>43</sup>

### *2.7.1 Objectivity*

Objectivity is the measure of to what extent the researcher and interviewees affects his or her study. An objective researcher should have a neutral point of view towards the study and there should be no signs of bias.<sup>44</sup>

#### *How will Objectivity be Guaranteed?*

Weekly meetings with the head of operations at Company A will ensure that the authors' bias will not affect the key decisions made throughout the project. In addition to this, interviews will be conducted with several people such as production manager, product development manager etc. to ensure that all aspects are considered.

### *2.7.2 Reliability*

Reliability is concerned with whether the results of a study are repeatable. If another researcher would later on try to conduct the same study, the results should be the same, if the first study was done in a reliable way.<sup>45</sup> In order for a study to be reliable, it should be clearly stated what the aims of the research and its basic premises were, how the research was undertaken, and the reasoning behind key decisions made.<sup>46</sup>

#### *How will Reliability be Guaranteed?*

Methods and assumptions will be documented thoroughly together with the data. When conducting an interview, the interviewee will be presented with the questions in written form. This is to ensure that no misunderstanding will occur. Observations and measurements will be executed with both authors present to ensure no mistakes or misinterpretations will occur. Since the work process for a company is an ever changing process it will be difficult for another researcher to get the same exact results as the authors, when conducting the same study.

---

<sup>43</sup> Denscombe, p. 273, 2003

<sup>44</sup> Ibid, p. 273

<sup>45</sup> Runeson et al., p. 154, 2008

<sup>46</sup> Denscombe, p. 274, 2003



### 2.7.3 Validity

When speaking of the validity of a study it is referring to the integrity of the conclusions. Validity can be divided into two categories:

- Internal validity: Internal validity is concerned with causality between factors. If the study shows x causes y, are we sure that it is x that is responsible for variations in y and not some other factor.<sup>47</sup> If the researcher is not aware of this other factor or does not know to what extent it affects y then this is a threat to the internal validity of the study.<sup>48</sup>
- External validity: External validity is concerned with whether the results of the study can be generalised beyond the specific research context.<sup>49</sup>

#### *How will Validity be Guaranteed?*

Measured processes will be clearly defined and thoroughly investigated to identify all factors influencing the measured process, thus ensuring internal validity. Due to an ever changing work process, generalizability will be difficult to generate, thus external validity will be disregarded.

## 2.8 The Relationship between Strategy and Methodology

The authors have visualised the relationship between the chosen strategies on how to conduct the project with the corresponding methodology. Visualised in figure 2.1, is the different phases of the study and how they relate to different methodologies. Furthermore, these different phases will require various approaches in order to collect data, what type of data that is to be collected and how argumentation should be conducted.

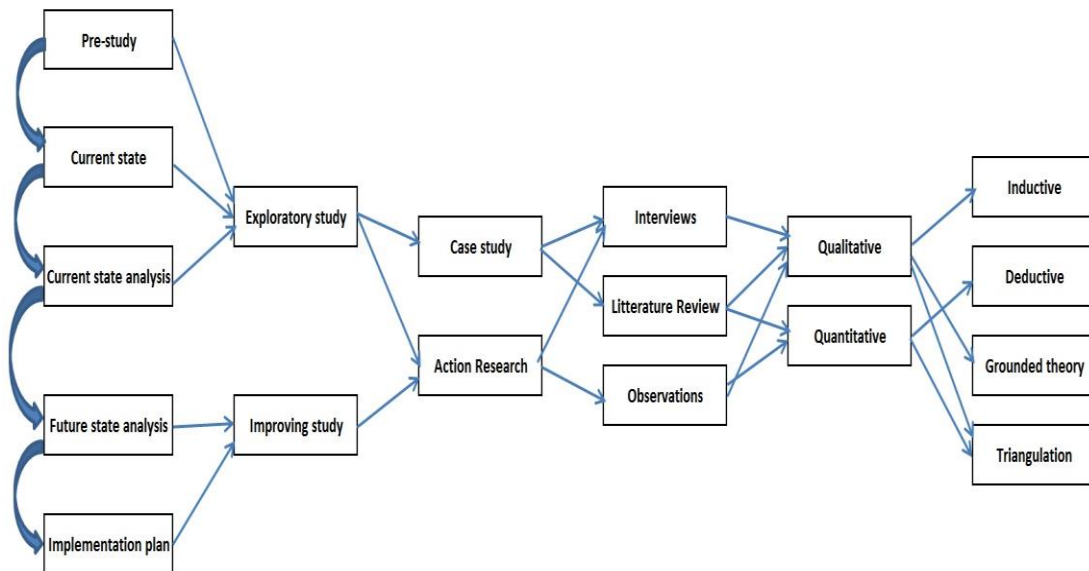

**Figure 2.1** The relationship between strategy and methodology

<sup>47</sup> Bryman, p. 47, 2012

<sup>48</sup> Runeson, p. 154, 2008

<sup>49</sup> Ibid, p. 154



## 3 Frame of Reference

*Important theories, methods and tools utilised during the thesis have been reviewed in this chapter. Provided to the reader is theory on product realisation, the production system, product engineering design and Lean production.*

### 3.1 Product Realisation

A company needs to plan and develop the processes required for product realisation according to the standards. The product realisation processes (PRP) are those processes needed to specify, develop, produce and supply the product or service required. The planning should define the processes necessary for producing the product features required to meet customer demands. When planning these resources one will determine the processes needed for the specific project, contract or order and determining their sequence and interrelation. The product realisation planning is the overall planning in order to meet all requirements for a project, product, contract or order.<sup>50</sup>

It is necessary to establish frameworks on what processes are needed to produce the organisation's product or service so that planning to meet a specific order does not commence from a blank sheet of paper. The framework serves as an aid to help the planner in deciding on the specific processes, actions and resources required for specific projects, contracts or orders. Frameworks will be set on a general level and may not contain detail information on specific products, dates, equipment, personnel or product characteristics. These may need to be determined individually, and therefore the need to plan and develop processes for product realisation<sup>51</sup>.

The ISO 9001 requires the organisation to control design and development of the product. These requirements can be viewed in Clause 7.3 of ISO 9001:2008. A design can be as simple as replacing an existing part with a new developed one, or as complex as designing a new product or system. The ISO 9001:2008 requirements apply to the product that will be provided to the customer including packaging. To control design means to assure that the design is on course towards its objectives with minimal factors preventing the design from achieving them. To control any design activity there are ten primary steps, according to Hoyle, one need to follow in the design process<sup>52</sup>:

1. Establish the customer needs.
2. Convert the customer needs into a definitive specification of the requirements.
3. Plan for meeting the requirements.
4. Organize resources and materials for meeting the requirements.
5. Conduct a feasibility study to discover whether accomplishment of the requirements is feasible.

---

<sup>50</sup> Hoyle, pp. 408-409, 2009

<sup>51</sup> Ibid, p. 409

<sup>52</sup> Ibid, pp. 449-451

6. Conduct a project definition study to discover which of the many possible solutions will be the most suitable.
7. Develop a specification that details all the features and characteristics of the product or service.
8. Produce a prototype or model of the proposed design.
9. Conduct extensive trials to discover whether the product, service or process that has been developed meets the design requirements and customer needs.
10. Feed data back into the design and repeat the process until the product or service is proven to be fit for the task.

These steps are necessary to control the design process in terms of reflecting customer needs and controlling input, the selection of components, standards, materials, processes, techniques and technologies, and the outputs. However, it is not aimed to control creativity of the designers.<sup>53</sup>

Hoyle states that if there is no control over the design and development processes several possibilities may occur<sup>54</sup>:

- Design will commence without an agreed requirement.
- Cost will escalate as designers pursue solutions that go beyond what the customer really needs.
- Costs will escalate as suggestions get incorporated into the design without due consideration of the impact on development time and cost.
- Designs will be released without adequate verification and validation.
- Designs will be expressed in terms that cannot be implemented economically in production or use.

Other important requirements are; Planning design and development, Inputs to the design and development process, Outputs from the design and development process, Design reviews, Design verification, Design validation and Control of design changes. A typical flow of the design and development process is visualised in figure 3.1.

---

<sup>53</sup> Hoyle, p. 451, 2009

<sup>54</sup> Ibid, p. 451

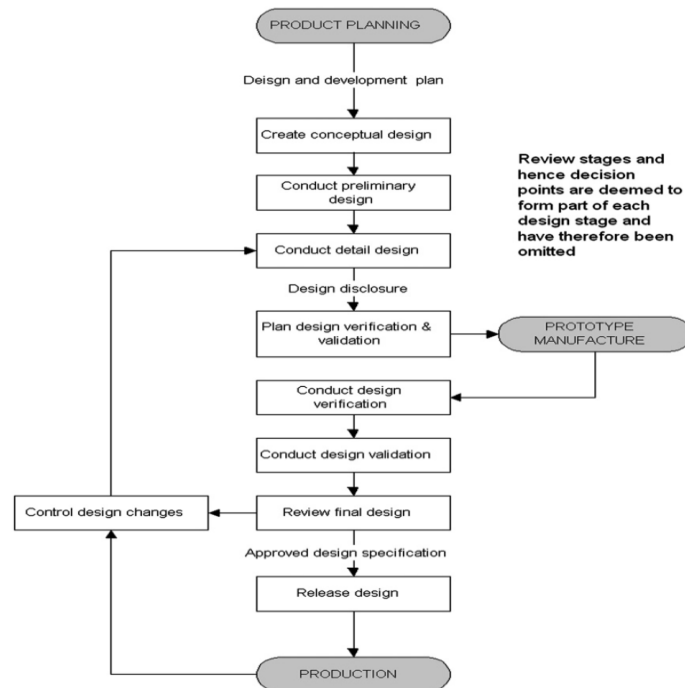

**Figure 3.1**<sup>55</sup> Product design process flow

These stages are subject to the ten earlier mentioned primary steps to control the design process. The areas that should be controlled are; Establish objectives for the design process, establishing measures for indicating achievements of these objectives, sub-processes or tasks that transform design inputs to outputs, availability of human and physical resources when required, and review stages to establishing that the process is achieving its objectives.

The ISO 9001 standard also requires the organisation to plan and carry out production and service provision under controlled conditions. The referred process of the standard is the result producing process, the process of implementing or replicating the design. The process differs from the design process since it is arranged to reproduce products or services to the same standard every time following a proven path with a predictable outcome, while the design process is a journey into the unknown. An organisation can control the product quality in two ways: either by controlling the product that emerges from the producing process or by controlling the processes through which the product passes. The difference being that process control relies on control of the elements that drive the process, whereas product control relies on verification of the product as it flows through the processes. In reality a combination of the two will yield products of consistent quality. An organisation needs to control its conditions in order to achieve its objectives. If there were no

<sup>55</sup> Hoyle, p. 452, 2009

control, outputs would be the result of chance and totally unpredictable. Planning of production requires three levels<sup>56</sup>:

- Identifying which processes are required to produce products;
- designing, commissioning and qualifying these processes for operational use; and
- routing the product through the appropriate qualified processes.

Hoyle states that to ensure that the processes are performed under controlled conditions the production plans need to<sup>57</sup>:

- Identify the product in terms of the specification reference and its issue status;
- define the quantity required;
- define which section is to perform the work;
- define each stage of manufacture and assembly;
- provide for progress through the various processes to be recorded so that one know what stage the product has reached at any given time;
- define the special tools, processing equipment, jigs, fixtures and other equipment required to produce the product;
- define the methods to be used to produce the product either directly or by reference to separate instructions;
- define the environment to be maintained during production of the product if anything other than ambient conditions;
- define the process specifications and workmanship standards to be achieved;
- define the stages at which inspections and test are to be performed and the methods used;
- define any precautions to be observed to protect health, safety and environment.

It is important that processes, products and facilities are developed in parallel otherwise a product might not reach the market when required. To achieve parallel development, the term concurrent engineering has emerged in order to optimise the relationship between design and manufacturing functions. New designs should not only be designed for existing facilities. Rather products should be designed that will give the organisation a competitive edge, hence laying down facilities that will be able to fulfil that promise. Visualised in figure 3.2 is the interface between the discussed aspects of product realisation. These plans will create a platform for ensuring that work is performed under controlled conditions. However, the staff, equipment, materials, processes and documentation must be up to the task before the work starts<sup>58</sup>.

---

<sup>56</sup> Hoyle, pp. 518-520, 2009

<sup>57</sup> Ibid, p. 520

<sup>58</sup> Hoyle pp. 520-521, 2009

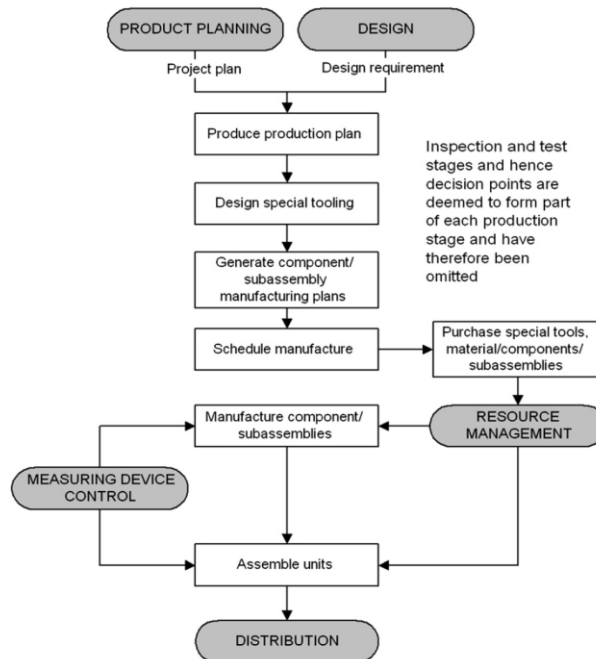

**Figure 3.2**<sup>59</sup> Typical production process flow.

## 3.2 The Production System

### 3.2.1 Process Choice

To choose the appropriate way in which to manufacture a product, a business will take the following steps:

1. Decide on how much to buy from suppliers which results in how much to make in-house.
2. Identify the appropriate engineering/technology alternatives to make a product to its technical specifications. This also concerns bringing together the sourced components with those made in-house, to produce a final product at agreed levels of quality conformance.
3. Choose between alternative manufacturing approaches in order to produce the products involved. This will need to reflect the market in which a product competes and the volume associated with those sales<sup>60</sup>.

The process choice concerns step three in the above explained procedure. It will need to reflect the decisions made in the first two steps and recognise any constraints imposed by them. When reflected upon, then the task is to choose the most appropriate way to manufacture, given the market and associated volumes involved.<sup>61</sup>

<sup>59</sup> Hoyle, p. 521, 2009

<sup>60</sup> Hill et al., p. 140, 2011

<sup>61</sup> Hill et al, p. 140, 2011

There are five generic types of manufacturing processes: project, jobbing, batch, line, and continuous processing. Although in reality, hybrids have been developed to blur the distinctions between the processes.<sup>62</sup>

- **Project** – Products that cannot be moved after completion will use this process choice. Resources are brought to the site where the product is built. Resources are only allocated for the duration of the job and will be reallocated when the job is completed. Product categories will include both special and standard. Some examples of special products are: the Sidney Opera House, and Oresund’s Bridge between Malmoe and Copenhagen. Standard product categories will include for example: Estates housing and prefabricated industrial and warehousing units<sup>63</sup>.
- **Jobbing** – When a product can be moved and is unique in the term of only being produced once, jobbing is the most suitable process choice. Instead of producing on site, the product will be produced in-house typically by one person or a group of skilled people. The task often requires the provider to install and commission the product as a part of the job. Some examples of products suited for jobbing are: Formula one and Indy racing cars, Injection moulding tools, and Ocean-going racing yachts<sup>64</sup>.
- **Batch** – This type of process is chosen to cover a wide range of volumes/order quantity size. When utilising a batch process, the job is divided into a number of steps. How many steps will depend on the complexity of the product involved, where a simple product can be completed by one step and a more complex by a number of steps. The order quantity is manufactured by setting up the first process step necessary, where the whole order quantity is completed. Then the next operation is setup and the total order quantity is completed, and so on, until the all required operations are completed in order to make the product. Meanwhile, the first operation is setup to complete a process for another product and so on. Meaning capacity is used and reused to meet different requirements of different orders<sup>65</sup>. Batch is chosen for standard products where volumes are insufficient in order to dedicate processes to them. Some examples of products suited for batching are: Business cards, Golf tees, Packaging, and Plastic bottles<sup>66</sup>.
- **Line** - Higher volumes mean that a product or product range can have dedicated processes since there is no need for resetting them. The operations to make the products are sequentially laid out in line where to product goes from step to step until completed. Some examples of products suitable for line process are: Cans of Coca-Cola, Pet food, and Automobiles<sup>67</sup>.
- **Continuous processing** - For some products the high volume involved needs to be processed in a specific way, for example, through piping or in liquid

---

<sup>62</sup> Ibid, p. 142

<sup>63</sup> Ibid, p. 153

<sup>64</sup> Ibid, p. 153,

<sup>65</sup> Ibid, pp. 144-145

<sup>66</sup> Ibid, p. 153

<sup>67</sup> Ibid, p. 153



form, thus continuous processing is most suitable. Continuous processing is similar to line, however the time and costs associated to a reset are higher. Some examples of products suitable are: Oil refineries, some chemicals, and Petrochemicals<sup>68</sup>.

### 3.2.2 Push and Pull

There are two main production control systems, push and pull. The key difference is the way work is triggered: in a push system the work is triggered from outside of the system, while work is triggered from inside in a pull system.<sup>69</sup> Provided below are two definitions of push and pull systems.

Definition one: A push system schedules the release of work based on demand, while a pull system authorises the release of work based on system status.<sup>70</sup>

Definition two: A pull production system is one that explicitly limits the work in process (WIP). By default a push production system is one without explicit cap on the system's WIP.<sup>71</sup>

Make-to-order (MTO) and make-to-stock (MTS) is another way of describing a push and pull system, where make-to-order is a push system due to the nature of a system driven by its orders rather than system status, and make-to-stock is a pull system driven by stock-level trigger points or in other words, the system status. This is obviously a theoretical distinction between the two, and real-world systems have aspects of both pull and push.<sup>72</sup> A make-to-stock approach is suitable when there is a need to supply the customer from readily available stock. This will give a quick service but at the expense of carrying stock. A make-to-order approach does not carry finished goods, since production is only carried out when there is an order. This approach is suitable when the final product has a high degree of variability and forecasting is unrealistic.<sup>73</sup>

MTO and MTS can be described as the customer order decoupling point (CODP), adding to these are two other frequently used CODPs, engineer-to-order (ETO) and assemble-to-order (ATO). The CODP function is to separate decisions made under certainty from decisions made under uncertainty in regards to customer demand. Figure 3.3 shows the degrees of certainty (commitment) and uncertainty (speculation) in customer demand linked to its respective strategy<sup>74</sup>.

---

<sup>68</sup> Hill et al, p. 153, 2011

<sup>69</sup> Hopp, p. 340, 2001

<sup>70</sup> Ibid, p340

<sup>71</sup> Marklund, 2012

<sup>72</sup> Hopp, p. 340, 2001

<sup>73</sup> Rowbotham et al, p. 250, 2007

<sup>74</sup> Rudberg et al., p. 447, 2004

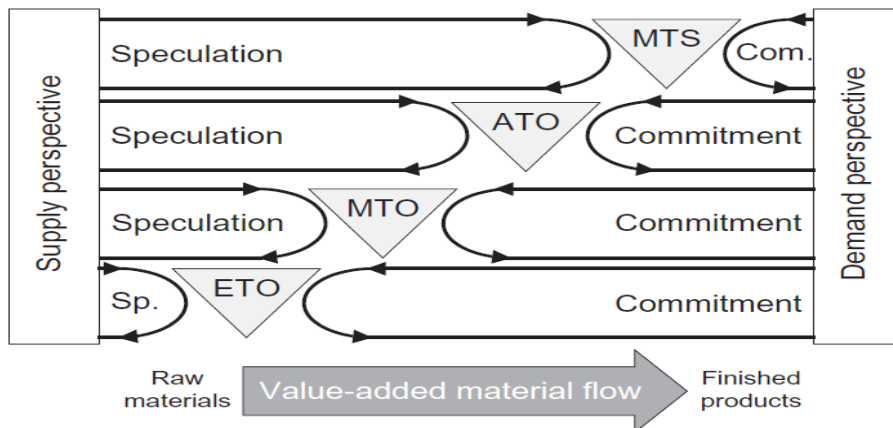

**Figure 3.3**<sup>75</sup> CODPs and the associated speculations and commitments

When scholars adopt this sequence there is no regard in the differentiation of engineering and production. In contrast to the traditional CODPs visualised in figure 3.3 there is also a two dimensional approach in order to integrate engineering resources with the operational process. Show in figure 3.4 below is the relationship between the traditional CODPs and their corresponding two dimensional CODPs. By using the CODP tuples one can acknowledge that customers can influence either the production or engineering dimension or both. An example of this is when modules are standard products that are produced to forecast, but some modules can be modified by the customer before they are assembled to order. This situation has aspects of both ATO and ETO in the traditional classifications. However, when using the two dimensional CODP approach the company can be classified as  $ATO_{\text{EngineeringDimension(ED)}}$  and  $ATO_{\text{ProductionDimension(PD)}}$ . The matrix in figure 3.4 shows the degree of customer involvement measured in time. In the top left corner one can find  $ETO_{\text{ED}}$  and  $MTO_{\text{PD}}$ , in this situation all engineering and production activities are preformed to customer order specifications. The opposite extreme is  $ETS_{\text{ED}}$  and  $MTS_{\text{PD}}$  where both engineering and production are performed without customer involvement. A third corner, bottom left, is  $ETS_{\text{ED}}$  and  $MTO_{\text{PD}}$  where all engineering activities are performed before consideration of customer involvement. CODPs can be infeasible due to the fact that engineering must be performed before any product can be produced<sup>76</sup>.

<sup>75</sup> Rudberg et al., p. 447, 2004

<sup>76</sup> Rudberg et al., p. 448, 2004

Traditional CODPs	Traditional CODPs in terms of	
	Engineering CODPs	Production CODPs
ETO	$ETO_{ED}$	$MTO_{PD}$
–	$ATO_{ED}$	$MTO_{PD}$
MTO	$ETS_{ED}$	$MTO_{PD}$
–	$ATO_{ED}$	$ATO_{PD}$
ATO	$ETS_{ED}$	$ATO_{PD}$
MTS	$ETS_{ED}$	$MTS_{PD}$

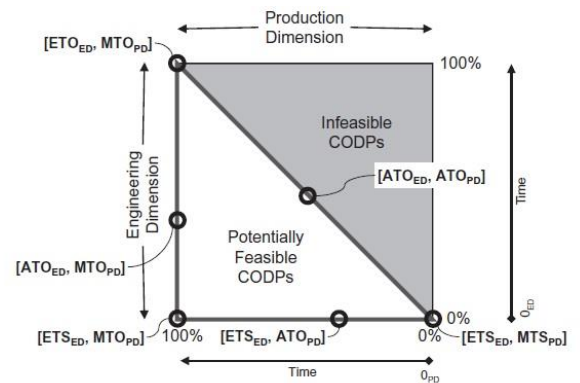

**Figure 3.4**<sup>77</sup> The extended model on CODP, which consider both the engineering and production dimensions.

By introducing the two dimensional approach for CODPs a comprehensive typology has been defined. This will better reflect reality than the traditional CODPs have and hence greater acceptance of analysis made based on the CODP theory<sup>78</sup>.

### 3.3 Product Development

*This sub-chapter will go through theory of the Stage-Gate process model which is similar to the product development process used at Company A. Afterwards the theory of a number of design strategies will be explain deemed suitable for this study with the main purpose of increasing the efficiency and flexibility at the company. Lastly, since some of these design strategies can be difficult to distinguish from each other, the relationship between them will be clarified.*

#### 3.3.1 Stage-Gate Process Model

Many companies have developed a systematic product development process known as a Stage-Gate process. A Stage-Gate breaks the innovative product development process down into a predetermined set of stages, each consisting of prescribed, multifunctional, and parallel activities. There are four, five, or six of these stages in the process, depending on the company. Each of these is designed to gather information needed to move the project into the next stage. However, before each stage is a gate, which is a checkpoint for a go or a kill decision, where the information gathered is assessed. These gates have “must meet” requirements and “should meet” desirable characteristics that are predefined and are usually manned by senior managers of the company. The multifunctional and parallel characteristics of the stages mean that concurrent engineering is a necessity in order for them to be met. Companies usually develop their own Stage-Gate process moulded to fit their profile but the stages tend to follow the same pattern<sup>79</sup>:

<sup>77</sup>Rudberg et al., p. 448, 2004

<sup>78</sup>Wikner et al., p. 639 2005

<sup>79</sup>Cooper et al., pp. 6-8, 2001

- Stage 1: Preliminary Investigation
- Stage 2: Detailed Investigation
- Stage 3: Development
- Stage 4: Testing and Validation
- Stage 5: Full Production and Market Launch

Often 6 to 18 months after the products commercialisation, the company terminates the product project. At this point, management reviews the project's performance. This is done to assess its strengths and weaknesses in order to learn from the project what can be done better the next time.<sup>80</sup>

The Stage-Gate process is characterised by its attempts to foresee and analyse future constraints and opportunities and to “freeze” the fundamental decisions regarding the product and the production process. This kind of anticipation strategy leads to extremely structured development models and a clear separation between concept development and implementation.<sup>81</sup>

### 3.3.2 Design for Manufacturing and Assembly

Design for Assembly (DFA) is one of the first members of the Design for X (DFX) family of tools in manufacturing industries. The expansion of the DFX families was fostered by the need for better decision making upfront, in particular those related to manufacturing. Tools for DFA were first developed in the 1970s and resulted in two different commercial tools: the Boothroyd and Dewhurst and the Lucas DFA, where the Boothroyd-Dewhurst tool moved on to include manual assembly. The success of this move led to the expansion of the DFX families to include Design for Manufacturability (DFM), Design for Reliability (DFR), and more. The DFX is an effective approach to implementing concurrent engineering, and focuses on techniques that are part of the detail design and an ideal approach to improve life-cycle costs, quality, increased design flexibility, and increased efficiency and productivity.<sup>82</sup>

In DFA, assembly refers to the combination of components into a product and the support work during and after production.<sup>83</sup> The focus of DFA is placed on factors relevant to the assembly: size, symmetry, weight, orientation, and form features, as well as handling, gripping, and insertion. These factors and their relationships are studied in order to ease the assembly process since the quality of this process depends on the type and number of operations and on their execution. These in turn depend on the layout design of the product, the form design of the components, and on the production.

DFM and DFA can both be systematically used to analyse design parameters (DP) that can be defined as a part or subassembly for manual or automated manufacture and assembly to reduce waste. Waste can most effectively be eliminated through the

---

<sup>80</sup>Cooper et al., pp. 6-8, 2001

<sup>81</sup>Biazzo, pp. 338-339, 2009

<sup>82</sup>Yang et al., pp. 307-308, 2003

<sup>83</sup>Pahl et al., p. 375, 2007

use of DFMA by: (1) getting rid of assembly directions that need several additional operations and (2) removing DPs with unnecessarily tight tolerances. One should also try to minimise the number of setups and stages through which a high-level DP must pass through to become a physical entity.<sup>84</sup> With DFMA, significant improvements can be made through simplicity thinking, especially by reducing the number of standalone parts in a product. The Boothroyd-Dewhurst DFA methodology follows three criteria that can help a designer greatly when examining each part as it is added to the assembly:

1. During operations of the product, does the part move relative to all other parts already assembled?
2. Must the part be a different material than, or be isolated from, all other parts already assembled? Only fundamental reasons concerned with material properties are acceptable.
3. Must the part be separate from all other parts already assembled because the necessary assembly or disassembly of other separate parts would otherwise be impossible?

A “Yes” to any of these criteria indicates that the part must be a separate part. A “No” to all would mean that the part can theoretically be removed or physically coupled with other parts.<sup>85</sup>

The objective of the DFM is to enable the designer to weigh alternatives, assess manufacturing cost, and make trade-offs between physical coupling and increased manufacturing cost. With DFM, this is done through experimental data for estimating costs of different processes.<sup>86</sup>

### 3.3.3 Modularity

Modularity or modular design has in recent years become a common household name in engineering. If a product was to fulfil different functions, many variants would have to be developed, usually with a costly design and production process. A modular design would enable the function variation through a combination of fixed individual parts or assemblies. In other words, a modular product fulfils various overall functions through the combination of distinct function units or modules.<sup>87</sup> In the ever-ongoing pursuit for improvements in the Lean Production philosophy, modularisation is becoming a more popular design strategy.<sup>88</sup> Modules have a one-to-one mapping from functional elements in the function structure to the physical components of the product, shown in figure 3.5.<sup>89</sup> Many textbooks encourage beginning the design process by establishing a function structure first, and then exploring this structure in search of possible modularisation opportunities.<sup>90</sup>

---

<sup>84</sup> Yang, p. 310, 2003

<sup>85</sup> Ibid, p. 312

<sup>86</sup> Ibid, pp. 313-314

<sup>87</sup> Pahl et al., p. 495, 2007

<sup>88</sup> Boothroyd et al., p. 1

<sup>89</sup> Ulrich, p. 422. 1993

<sup>90</sup> Fixson, p. 86, 2007

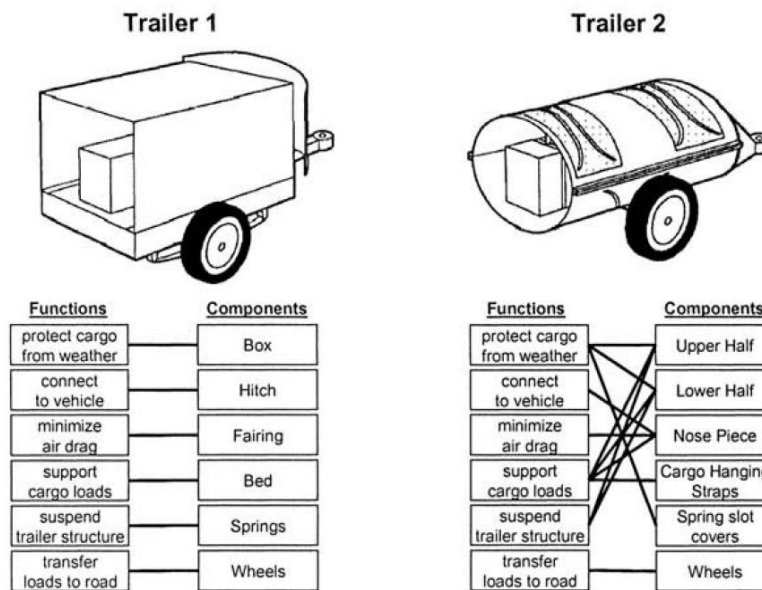

**Figure 3.5**<sup>91</sup> Trailer 1 with modular product architecture and trailer 2 with integrated product architecture

Combining modules and thus sharing them across product variants allows development costs and capital expenses to be amortised across a greater number of units and promotes higher production efficiency through higher volumes, which is well in accordance with Lean Production as it is always looking to cut costs and optimise processes<sup>92</sup>. The challenge that comes from a modular design is to define a set number of standard components that combine to satisfy the needs of the greatest number of customers, since satisfying all could put too much pressure on the manufacturing process.<sup>93</sup>

Since a modular system's overall function results from a combination of modules, more emphasis has to be put on the design efforts during the conceptual and embodiment phases.<sup>94</sup> This effort is important in order to avoid designing too specific in terms of compatibility to the platform; hence the most critical aspect of the design is the interface.<sup>95</sup> If the chosen interface fails to be useful in a wide array of applications, the assembly will lose its value as a module. In order to avoid this, the interface has to be strictly controlled throughout its life cycle.<sup>96</sup>

A modular architecture can be divided into three sub-types, each having a one-to-one mapping, and a de-coupled design between interfaces. De-coupled meaning that a

<sup>91</sup> Simpson et al., p. 312, 2005

<sup>92</sup> Boothroyd et al., p. 1

<sup>93</sup> Walton, pp. 46-47, 1999

<sup>94</sup> Pahl, p. 495, 2007

<sup>95</sup> Simpson, p. 349, 2005

<sup>96</sup> Boothroyd et al, p. 2

change is made to one component does not require a change to the other component in order for the overall product to work correctly. The three sub-types are:

- Slot: Each of the interfaces between components in this architecture is different from the other, in order to avoid the components in the product to be interchanged.
- Bus: There is a common bus to which the other physical components connect via the same interface.
- Sectional: All interfaces are of the same type and there is no single element to which all the other components attach. They are instead connected to each other via identical interfaces.<sup>97</sup>

Most real products, however, exhibit some combination of characteristics from several of these sub-types and are rarely as idealised as the example from figure 3.5 above. The sub-types can also depend on at what level the product is observed from, an overall final assembly can have a quite different architecture from the architecture on a level of individual parts or subassemblies.<sup>98</sup>

Most products will undergo some change during their life and these can be done in several different forms:

- Upgrade
- Add-ons
- Adaption
- Wear
- Consumption
- Flexibility

Modularity can be of great help to accommodate each of these cases to a product.<sup>99</sup> Several reasons, or drivers, have been identified as to why modularity, in the form of the cases stated, is implemented. These drivers can be related to the products development, variety, production, procurement, or quality.<sup>100</sup> Two of the most common drivers, commonality and differentiation, will be explained more thoroughly in chapter 3.3.3.1 and 3.3.3.2.

### 3.3.3.1 Commonality

Commonality can in a very general sense be described as the idea to make each product within a family identical in ways that customers cannot see without preventing the product variants to be distinct in ways that customers notice. However, it is a concept that can be hard to implement correctly because of its many different kinds of methods and metrics.<sup>101</sup> An important part of implementing commonality in a product family lies in properly balancing it with the distinctiveness of each product in the family. This results in the designers having to coordinate the challenges with product design with the complexity of designing for multiple products in an effort to

---

<sup>97</sup> Ulrich, pp. 422-424, 1993

<sup>98</sup> Ibid, p. 424

<sup>99</sup> Ulrich, p. 427, 1993

<sup>100</sup> Blackenfelt, p. 7, 2001

<sup>101</sup> Thevenot et al., p. 578, 2007

increase commonality without risking its distinctiveness.<sup>102</sup> A high degree of component commonality can lead to a reduced frequency of setups needed in production. Simulation analysis performed on operational performance in production by Collier showed that the total cost increased as the degree of commonality on products decreased. However, if commonality increases, it has showed that the workload at the workstations decreased due to infrequent setups, and purchasing costs decreased due to larger order quantities, which resulted in better economies of scale.<sup>103</sup>

One way of measuring commonality, according to Kota et al in *A Metric for Evaluating Design Commonality in Product Families*, is to measure the fraction of parts that is shared across a product family relative to the parts that could have been shared, adjusted for materials, manufacturing and assembly processes. This method of measuring commonality uses the company's Bill of Materials (BOM) and is known as the Degree of Commonality Index (DCI).<sup>104</sup> There is several other component-based commonality metrics developed that are based on and around the DCI. Another way to measure commonality is through product similarity in brand reputation and feature presentation. It is found that companies with high brand value tend to have a high degree of commonality in relation to low brand value companies. Commonality is not limited to physical parts but can be applied to processes, organisations or innovation as well.<sup>105</sup>

### 3.3.3.2 Differentiation

Differentiation, or variety, is one of the main drivers in having a module based product design. A demand for customised products is largely driven by the globalisation of the market. As an example, the need for a country-specific product is the result of this.<sup>106</sup> The idea with managing variety with modularity is to have common and variant modules that should be combined to easily create the desired product variety. The strategy is then to differentiate the parts of the product where customer value is represented through variety and keep the other parts common throughout the product family. In this sense, both drivers can be present in the same strategy.<sup>107</sup>

Product variety can be separated into two types: product variety and component variety, which is called external variety and internal variety respectively. In order to manage variety one needs to have a good balance and optimisation between external variety and internal variety with the goal to have as many external variants as necessary while having as few internal variants as possible.<sup>108</sup>

Product variety can also be described along two dimensions in which one represents different market segments and the other represents variety within the segments,

---

<sup>102</sup> Simpson, p. 5, 2005

<sup>103</sup> Blecker et al., p. 71, 2007

<sup>104</sup> Fixson, p. 85, 2007

<sup>105</sup> Ibid, p. 89

<sup>106</sup> Blackenfelt, p. 10, 2001

<sup>107</sup> Blackenfelt, pp. 12-13, 2001

<sup>108</sup> Blackenfelt, pp. 7-10, 2001



shown in figure 3.6 below. An example of this is in the automotive industry, where different equipment alternatives satisfy varying requirements within the segment, whereas different car models meet different segments.<sup>109</sup>

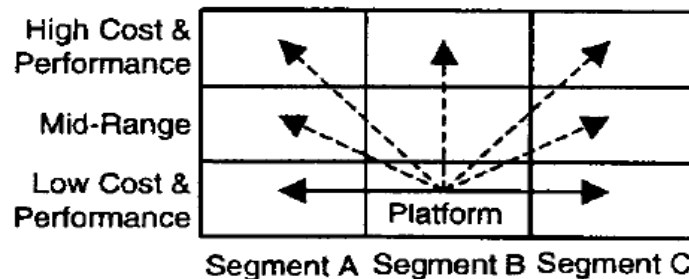

**Figure 3.6**<sup>110</sup> Market segmentation grid and platform leveraging strategy

Product variety design has been intensively studied with research topics widely spread from describing any successful implementation of product variety design in practice, developing methods and tools to support design implementation, and to create computational support through design automation. The design optimisation paradigm is found to be the most effective tool among computational design approaches to design product variety.<sup>111</sup>

### 3.3.4 Standardisation

Standardisation of a component is defined as the promotion of standard parts that are commercially available, since these are usually cheaper than custom ones. This may reduce the number of unique parts in a product, thus lowering the costs.<sup>112</sup> Component standardisation can concern components both within the single firm, known as internal standardisation, and across multiple firms, known as external standardisation. A component that is designed and manufactured within the firm classifies an internal standardisation and when a supplier provides it, it is classified as external standardisation.<sup>113</sup> When considering components, standardisation can reduce the number of uncertainties the development department has to cope with. By reusing standardised solutions such as components or modules rather than start from scratch every time, a company can save time and money as it requires no development resources. It can thus lower the complexity, cost and lead time for the product development department.<sup>114</sup> Also, by designing through the use of standard components it gives the customer the choice to choose repeatedly used and proven solutions at a better price and faster delivery time.<sup>115</sup>

Standardisation can concern not only physical entities but also departments of the organisation such as sales, engineering and purchasing. It is about developing efficient work processes to fully exploit standards. In order for the standardisation

<sup>109</sup> Ibid, p. 10

<sup>110</sup> Simpson et al., p. 4, 2001

<sup>111</sup> Simpson et al., p. 187-188, 2005

<sup>112</sup> Simpson et al., pp. 349-350, 2005

<sup>113</sup> Ulrich, p. 431, 1993

<sup>114</sup> Ulrich, p. 432, 1993

<sup>115</sup> Simpson et al., p. 494, 2005

strategy to work well within a company, it must be well communicated and understood as well as easy to access and maintain. It often comes down to the concept of information: for sales, necessary information such as brochures and technical datasheets should be easily acquired. Engineers should have easy access to 3D models and 2D drawings necessary to streamline the work process. BOM, past suppliers, and bulk of standards bought from the past, should be present for purchasing.<sup>116</sup>

### 3.3.5 Relationships within Modularity, and between Modularity and Standardisation

Implementing modularity is done for several different reasons and because of this researchers have different definitions of modularity and of what it includes. Modularity can through its various drivers support, conflict, and interact with each other. One of the main conflicts that occur is between commonality and differentiation. These two definitions are opposite of each other and yet both can be found in the context of modularity.<sup>117</sup> Although the definition of commonality is well in consensus through most research, the definition of modularity can still be complicated and may sometimes only be associated with product differentiation and thus defining commonality as a separate product strategy, along with standardisation, as it is done in *Product Platform and Product Family Design*.<sup>118</sup> Other literature defines both commonality and differentiation under modularity types but while commonality is held as one type, differentiation can take many different forms, as described in *Strategies for Lean Product Development*, where component swapping, mix modularity, bus modularity, and sectional modularity are all types of product differentiation.<sup>119</sup>

The descriptions and definitions used to create, measure, determine and test modularity come in a large variety that sometimes overlap with the definitions for commonality. In most of these cases modularity is only associated with differentiation. The logic of having similar components across products can be found in references to both modularity and commonality. The measurement of modularity and commonality also come in a large mixture. They can range from measuring directly on the component level to measuring on very abstract or indirect dimensions. This is another reason for the two's ease of mix up.<sup>120</sup>

Modularity and standardisation are both frequently mentioned together with product variety and can be easily mixed up. One way to differentiate them is to think of modularity on the assortment and product level, and standardisation on the component level.<sup>121</sup> The terms Bottom Up modularisation and Top Down modularisation can contribute to this confusion however as Bottom Up modularity involves cutting costs right at the source by reducing the amount of different components used. This is done to help product data management in tracking parts. It

---

<sup>116</sup> Simpson et al., p. 495, 2005

<sup>117</sup> Blackenfelt, pp. 9-10, 2001

<sup>118</sup> Simpson et al., p. 349, 2005

<sup>119</sup> Walton, p. 47, 1999

<sup>120</sup> Fixson, pp. 86, 89, 2007

<sup>121</sup> Blackenfelt, p. 10, 2001

is also done to assist the designers in choosing what preferred parts to use. This could be associated with both commonality and standardisation.<sup>122</sup>

Commonality and standardisation can be easily mistaken with each other as commonality, also called component sharing, could be defined as using the same parts, modules and subassemblies across multiple products or platforms to satisfy product requirements. This could according to many be associated with standardisation. However, standardisation of a component is defined as the promotion of standard parts that are commercially available.<sup>123</sup> Also, the level of standardisation can be assessed on one product alone through the number of standard components included. Commonality, on the other hand, can only be measured by comparing the components of a product with at least one other product in a product family.

A modular design with high component function commonality, as well as a component interface that is unison across more than one product, can then give rise to standardisation of that component. These criteria will make the component easily adapted into other products requiring the same or similar functions. When components are presented in a larger magnitude of products the components are being moved towards being standardised. This is a logical step to take in a manufacturing sense: a standardised component is usually less expensive because it will be produced in higher volumes, allowing greater economies of scale and a greater understanding, inducing a higher performance (for a given cost) compared to a custom component.<sup>124</sup>

### **3.4 The Lean Concept**

#### *3.4.1 Lean According to Liker*

When Liker describes Lean, he emphasises on the fact that Lean is more than a set of tools and techniques. Lean is broken down into four categories, also called the 4 P model, these are: Long-Term Philosophy (Philosophy), The Right Process Will Produce the Right Results (Process), Add Value to the Organisation by Developing Your People (People & Partners), and Continuously Solving Root Problems Drives Organisational Learning (Problem Solving). Adding to this are 14 principles distributed over the four categories, completing the Lean pyramid, shown in figure 3.7.

---

<sup>122</sup> Boothroyd et al., p. 2

<sup>123</sup> Simpson et al., p. 349-350, 2005

<sup>124</sup> Ulrich, p. 431, 1993

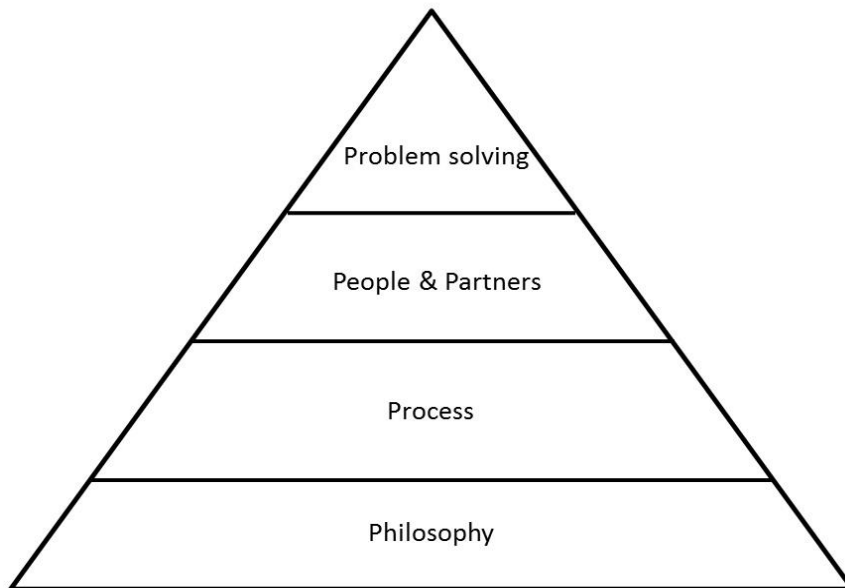

**Figure 3.7**<sup>125</sup> Liker's 4 P model

- Philosophy:
  - Make decisions on a long-term basis even if it is on the expense of short-term financial goals
- Process:
  - Create continuously flowing processes to find problems
  - Use pull systems to avoid overproduction
  - Level out the workload
  - Halt processes when problems occur
  - Use visual control so that no problems are hidden
  - Only use well tried and reliable technology
  - Standardise assignments is the base for continuous improvements and co-worker contribution
- People & Partners:
  - Respect your partners and suppliers by helping them
  - Develop people and teams that follow the philosophy of the company
  - Make sure management knows the business well, live by the philosophy and teach others
- Problem solving:
  - Go see by yourself to gain a better understanding
  - Make decisions slow and in consensus. Consider all alternatives and implement the chosen decision fast
  - Become a learning organisation by continuous reflection and improvements

---

<sup>125</sup> Liker, p. 19, 2004

#### 3.4.1.1 Philosophy

The foundation for all the other principles of the TPS 4P-model is its philosophy: Do the right thing for the company, its employees, the customer, and society as a whole. The philosophy is what should be consistent throughout the entire company, according to the TPS. It enables all the employees to feel a greater sense of purpose rather than just focusing on earning the next paycheck.<sup>126</sup> The directive of the company should be to base all the management decisions on a long-term philosophy even at the expense of short-term financial goals, which is principle one in the 4P-model.

Furthermore, this philosophy should be steadily implemented into every aspect of the company and should not be abandoned at the first sign of trouble. The only reason to change the philosophy of the company is if there is a fundamental shift in the world that threatens its long-term survival.<sup>127</sup> In other words, the philosophy should not appear overnight and should not be dropped overnight.

#### 3.4.1.2 Process

The TPS is based on the belief that the right process will create the right results. Several key principles form the second broad category of the TPS 4P-model known as Process. A good way for a company to start the journey of becoming lean is by creating continuous flow wherever applicable in its processes. According to TPS, creating flow will lead to the best quality, lowest cost, and shortest delivery time. Flow tends to force other lean tools into implementation. In creating flow, one lowers the inventory level throughout the value stream, and thereby exposes problems. It also forces the responsible to fix the problem because the low level of inventory will result in the whole system shutting down if it is not properly addressed.<sup>128</sup>

A true one-piece-flow system would mean zero inventory, which, in reality is not possible. The closest system to this is the pull system. Most of today's companies use a push system, where goods or services are often pushed onto the retailer whether or not the retailer can sell them right away, the retailer is then forced to push it onto the customer in the same order. This results in a lot of inventory for both the company and the retailer. A pull system is based on immediate customer demand, also known as just-in-time manufacturing. But since there are natural breaks in the flow of a product, from raw material to finished state, some inventory is necessary. These inventories between breaks are known as buffers and are small, controlled amounts that can be replenished systematically before they run out in a just-in-time manner.<sup>129</sup>

Following these principles is a good start in the lean process but since customers are not predictable, orders can vary significantly. This can result in a very uneven workflow with a lot of stress on the employees and machines on one occasion, and underutilisation on the next. To address this issue, one needs to even out the workload, and this is perhaps TPS's most counterintuitive principle, but essential in order to become Lean. It means that one does not build products according to the

---

<sup>126</sup> Liker, p. 86, 2004

<sup>127</sup> Ibid, p. 96

<sup>128</sup> Liker, pp. 102-103, 2004

<sup>129</sup> Ibid, pp. 118-121

actual flow of customer orders, but takes orders over a period of time and levels them out so that the same amount and mix is made every day.<sup>130</sup>

In order for lean to function properly, one have to build a culture of stopping to fix problems, to get quality right the first time. This will save time and money for a company, since issues caused upstream will not arise downstream.<sup>131</sup> A major consequence of implementing flow, is that it puts a lot of pressure on one to get the quality right the first time. But, by standardising tasks for continuous improvement, one can countermeasure the quality problems effectively. Standardisation should not, however, be seen also as only a way of making production tasks repeatable and efficient but also a way to continuously improve processes. Standardisation must first be done before continuous improvements can be a realisation and it should be practiced throughout the company on all levels.<sup>132</sup>

Any deviations from the set standards should stand out and be clearly indicated by sound, sight, or feel because humans are visually, tactilely, and audibly oriented. Therefore, a well-developed visual control system should be implemented, in order to increases productivity, reduce defects and mistakes, facilitate communication, improves safety, and give the worker an overall better control of their environment. The principle is to support your employees through visual control in order to give them the best opportunity to carry out their work<sup>133</sup>.

Having a physical and people-oriented system can seem obsolete considering how fast information technology is progressing and the development of computerised systems. But one should not avoid these systems. Instead, one should think creatively using whatever means is best to create visual control. An old system should not be replaced with a new one based solely on that it is cheaper and faster. The system should support the employee, not the other way around. That is why new technologies should be thoroughly tested through direct experimentation with the involvement of a broad cross-section of people within the company. Due to the thorough investigation, new technologies are smoothly implemented without employee resistance and process disruption.<sup>134</sup>

#### 3.4.1.3 People & Partners

At this level in Likers 4P model, the focus lies in people & partners. To be able to eliminate unevenness at an executive level, the leader should be grown and promoted within the company. This should be done in order to sustain the current culture at the company which often take many years to establish. This consistency of purpose will lay the groundwork and enable a learning environment within the company.<sup>135</sup>

A company needs to establish an excellent balance between individual and group work in order to balance the individual excellence and team effectiveness. Teams do

---

<sup>130</sup> Liker, p. 126-127, 2004

<sup>131</sup> Ibid, pp. 143-144

<sup>132</sup> Ibid, pp. 154-156

<sup>133</sup> Liker, p. 172, 2004

<sup>134</sup> Ibid, pp. 172-175

<sup>135</sup> Ibid, p. 187

not do value-added work, individuals do. Teams should coordinate the work, motivate and learn from each other. Teamwork should be the foundation of a company.<sup>136</sup>

A strong supplier relationship is necessary to be able to grow with them for mutual benefits. A lean supply chain can be established if suppliers are considered as a part of the extended family. Growing together does not mean that one should be soft and easy toward a supplier, on the contrary, tough goals and high expectations should be set, but with the respect of mutual learning and teaching.<sup>137</sup>

#### 3.4.1.4 Problem Solving

Creative and innovative thinking should be encouraged within a company. However, the first step of any problem-solving process, development of a new product, or evaluation, is grasping the actual situation. One should go and see for oneself and learn by doing, in order to thoroughly understand all aspects of the actual situation. Managers and employees should have a deep understanding of processes flow, standardised work etc. and also be able to critically evaluate and analyse what is going on in order to get to the root of the problem.<sup>138</sup>

In order to make the right decisions one need to thoroughly investigate alternative solutions, even though the considered solutions might seem outstanding. It will result in a lot of effort and time spent in planning, but will rapidly speed-up the implementation phase.<sup>139</sup>

In order to become a learning organisation, self-reflection and self-criticism should be considered a way to improve. Instead of blaming others when a mistake has occurred, one should learn from it and countermeasures should be identified to make sure it will not happen again. One way to getting to the root is the five why method, asking why five times will get one closer to the root of the problem.<sup>140</sup>

#### 3.4.2 The Five Whys

The fundamental objective of the five whys method lies in identifying the root cause of a problem. One will only scratch the surface of a problem when the source is identified. However, asking why five times will get one closer to the true problem, the root cause of it. Asking why five times often lead to upstream processes, for example; defects in assembly might be the cause of variation in thickness of the raw material, the variations could affect how the material is stamped, welded, and finally how it is assembled. By asking why five times, at least, would secure identification of the root cause. This means, for every why that is asked, the level of detail will be higher. By identifying the root case, the proper countermeasures can be chosen in order to prevent that the same problems occur again.<sup>141</sup>

---

<sup>136</sup> Liker, p. 201, 2004

<sup>137</sup> Ibid, p. 216

<sup>138</sup> Liker, p. 234, 2004

<sup>139</sup> Liker, p. 252, 2004

<sup>140</sup> Ibid, pp. 263-264

<sup>141</sup> Ibid, p. 264

### 3.4.3 Waste

*Muda* is the Japanese word for waste and it was the biggest foe of Taiichi Ohno, the founder of TPS. Waste in production is everywhere and can come in any variety, specifically any human activity that absorbs resources without adding value. Some examples are: mistakes which require rework, production of unwanted items, excessive processing which are not needed by the end customer, unnecessary handling of goods, unutilised downstream resources due to waiting on upstream activities to be completed, and goods and services not meeting the need of the end customer.<sup>142</sup>

Lean thinking is the antidote to waste. It will provide a way to specify value, lining up value creating activities in the most efficient way and conducting these activities without disruption, and perform them in the most effective way.<sup>143</sup>

Toyota has identified seven categories of waste, which they consider to be the worst kind of waste, where overproduction is the fundamental type of waste since it is the cause of most of the other wastes. Liker has included an eighth kind of waste, *unused employee creativity*, resulting in the eight kinds of waste<sup>144</sup>:

1. *Overproduction*. Producing items for which there are no orders, which generates such wastes as overstaffing and storage and transportation costs because of excess inventory.
2. *Waiting (time on hand)*. Workers merely serving to watch an automated machine or having to stand around waiting for the next processing step, tool, supply, part, etc., or just simply having no work because of stockouts, lot processing delays, equipment downtime or capacity bottlenecks.
3. *Unnecessary transport or conveyance*. Carrying WIP long distances, creating inefficient transport, or moving materials, parts, or finished goods into or out of storage or between processes is considered unnecessary transport.
4. *Overprocessing or incorrect processing*. Taking unneeded steps to process the parts. Inefficiently processing due to poor tool and product design, causing unnecessary motion and producing defects. Waste is generated when providing higher-quality products than is necessary.
5. *Excess inventory*. Excess raw material, WIP, or finished goods causing longer lead times, obsolescence, damaged goods, transportation and storage costs, and delay. Also, extra inventory hides problems such as production imbalances, late deliveries from suppliers, defects, equipment downtime, and long setup times.

---

<sup>142</sup> Wormack et al, p. 15, 2003

<sup>143</sup> Ibid, p. 15

<sup>144</sup> Liker, pp. 43-44, 2004



6. *Unnecessary movement.* Any wasted motion employees have to perform during the course of their work, such as looking for, reaching for, or stacking parts, tools, etc. Walking is also considered as waste.
7. *Defects.* Production of defective parts or correction. Repair or rework, scrap, replacements production, and inspection mean wasteful handling time, and effort.
8. *Unused employee creativity.* Losing time, ideas, skills, improvements, and learning opportunities by not engaging or listening to your employees.

Stated earlier was that overproduction is considered as the fundamental waste. If overproduction is allowed at any operation it will lead to a build-up of inventory somewhere downstream, leaving material just sitting there waiting to be processed at some point in time. Also, it will not encourage the behaviour of continuously improving the processes such as reducing the number of defects, since there will always be some excess inventory to cover for the defects thrown away. Figure 3.8 visualises an example of value-added time for producing an arbitrary part and its associated wastes<sup>145</sup>.

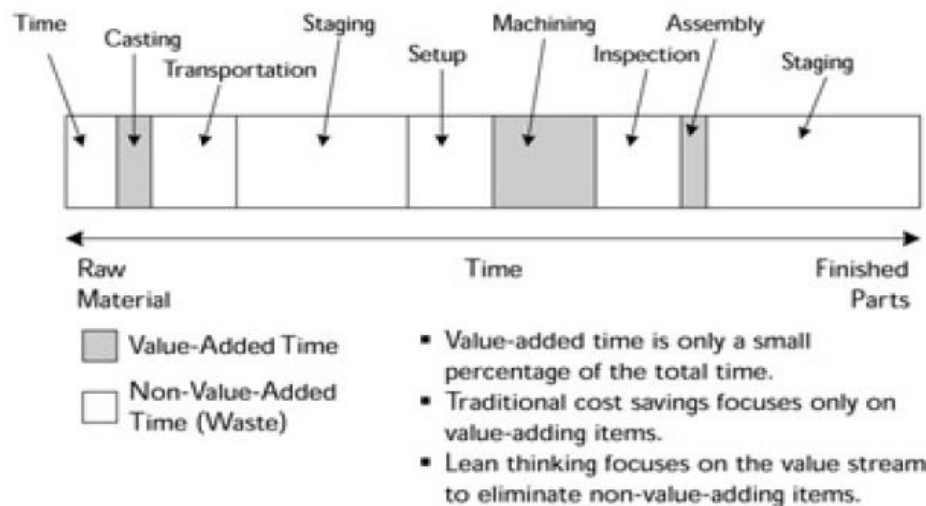

**Figure 3.8**<sup>146</sup> Wastes in an arbitrary value stream

A strategy needs to be established for an organisation to be able to tackle the identified wastes. A selection of two or three of the most important steps to eliminate waste has to be chosen and the others should be dealt with later. The reasoning behind this is that focusing on all wastes at the same time will only lead the organisation to get half way there since resources is usually scarce. Instead the organisation should focus on one thing at a time until completion is reached in a continuous improvement manner<sup>147</sup>.

<sup>145</sup> Liker, p. 44, 2004

<sup>146</sup> Liker, p. 45, 2004

<sup>147</sup> Womack et al, p. 95, 2003

## 3.5 Tools

### 3.5.1 The Deming Cycle – Plan-Do-Check-Act

The Deming cycle, also known as the PDCA cycle, is a continuous quality improvement model that consists of four repetitive steps, which follow a logical order. This model can be applicable on any level of a company, from project, to group, to company, and across companies, as long as they have a culture of continuous improvement.<sup>148</sup> The model could first be implemented through a pilot, where needed adjustments are made after reviewing the pilot results and implementation plan, and then expand it to the next desired level of the organisation.<sup>149</sup> The four steps are:

- *Plan* where improvement is needed. Gather data to develop a plan which will result in improvement.
- *Do*. Carry out the plan.
- *Check* whether or not there has been an improvement. Measure the outcome.
- *Action*. If the plan has been successful, it must be introduced in all parts of the business. If the outcome deviates from the plan, correct it.<sup>150</sup>

TPS has embodied this model of continuous learning, but by modifying it to focus on eliminating waste, seen in figure 3.9. It follows the cycle of creating one-piece flow, surfacing problems, creating countermeasures, and evaluating results.<sup>151</sup>

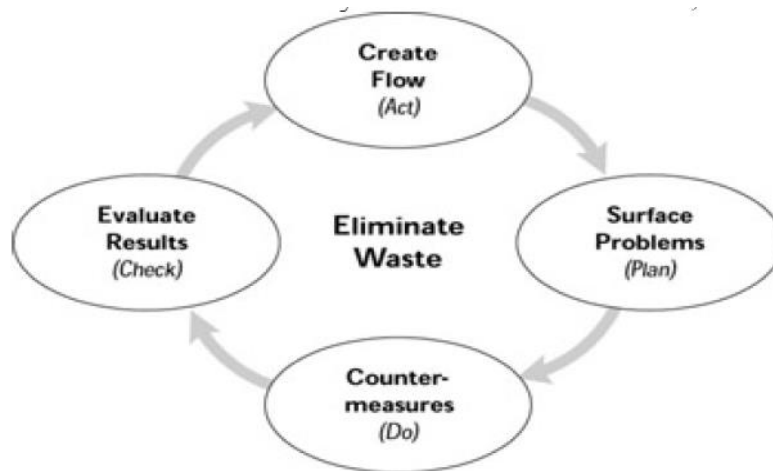

**Figure 3.9**<sup>152</sup> Lean Deming cycle

### 3.5.2 Single Minute Exchange of Die (SMED)

Setup time is the time required when a changeover is needed from producing one product to another. SMED is a tool used in Lean production with the main objective

<sup>148</sup> Rowbotham et al., p. 155, 2007

<sup>149</sup> John et al., p. 263, 2008

<sup>150</sup> Rowbotham et al., p. 155, 2007

<sup>151</sup> Liker, p. 276, 2004

<sup>152</sup> Ibid, p. 276

to reduce setup time in less than ten minutes, where “single minute” is considered as “single digit”. The setup time is considered as a non-value adding activity and is therefore categorised as waste.<sup>153</sup>

The possibilities and gains of reducing setup time is visualised in figure 3.10.

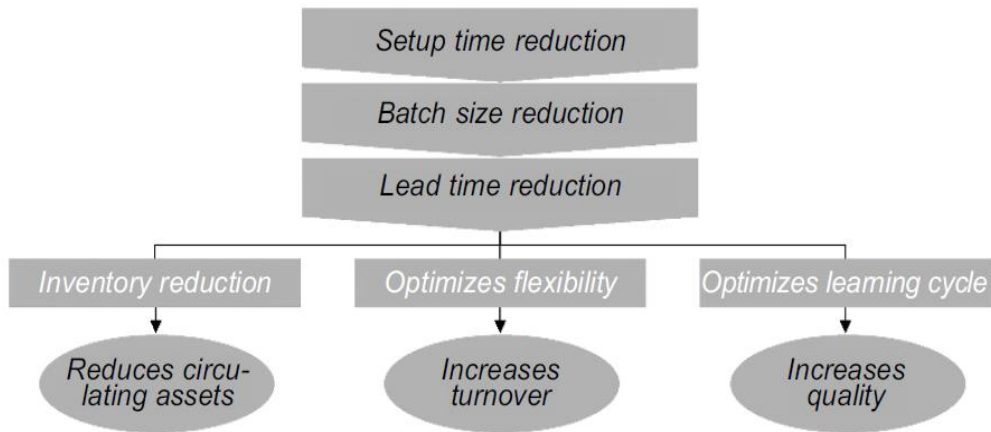

**Figure 3.10**<sup>154</sup> Benefits from setup time reduction

The definition of setup is the duration between the last good part of a batch and the first good part of the following batch. This is illustrated in figure 3.11.

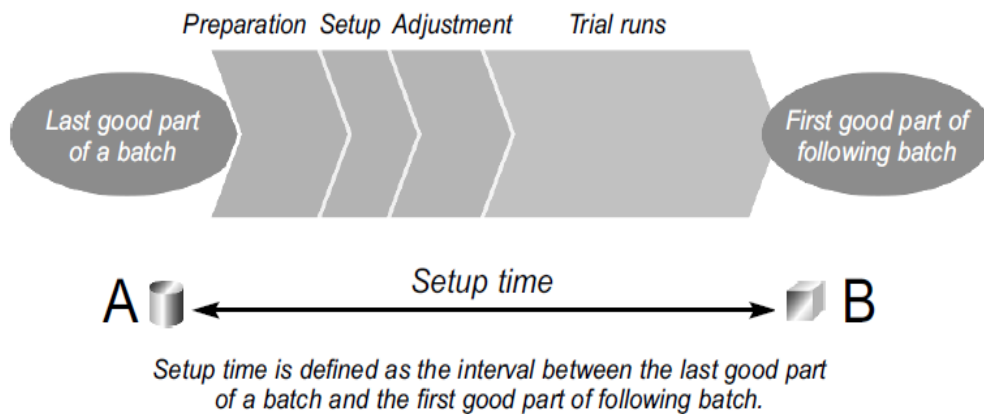

**Figure 3.11**<sup>155</sup> Illustration of the setup time definition

In order to successfully reduce setup times one should follow a four level process:

<sup>153</sup> Ulutas, p. 2, 2011

<sup>154</sup> John et al., p. 211, 2008

<sup>155</sup> Ibid, p. 212

- *Level 1:* One should document the setup process, separating the internal and external setup times.
  - Internal setup time: the time it takes for activities which can only be completed when the machine is shut down, for example, when tools are changed.
  - External setup time: the time it takes for supporting activities, which can be completed while machine is running.<sup>156</sup>
- *Level 2:* When a distinction has been made between internal and external setup times one should re-examine operations to secure that no steps are wrongly assumed to be internal. One should now convert internal to external setup times in the degree possible.<sup>157</sup>
- *Level 3:* Internal activities should be streamlined with the approach of simplifying, eliminating and reducing. Hand tools, and required nuts and screws should, in the degree possible, be reduced or eliminated.
- *Level 4:* Intuitive adjustments and trial runs should be eliminated and replaced by facts through standardisation. Visual control mechanisms should be used in order to reduce adjustment times caused by incorrect alignments, settings and measurements.<sup>158</sup>

### 3.5.3 Economic Order Quantity (EOQ)

The EOQ model plays a significant role in operations management. It is one of the earliest applications of mathematics in production with the objective of inventory control<sup>159</sup>.

The model was developed to solve the issue of how much to order or produce when considering the trade-off of tied up capital and ordering or setup costs.

In order to derive the mathematical model to determine the optimal batch size some assumptions had to be made about the manufacturing system, according to Ford W. Harris:

1. *Production is instantaneous.* There is no capacity constraint, and the entire lot is produced simultaneously.
2. *Delivery is immediate.* There is no time lag between production and availability to satisfy demand.
3. *Demand is deterministic.* There is no uncertainty about the quantity or timing of demand.
4. *Demand is constant over time.*
5. *A production run incurs a fixed setup cost.*
6. *Products can be analysed individually.* Either there is only a single product or there are no interactions between products.

---

<sup>156</sup> John et al., p. 212, 2008

<sup>157</sup> Shingo, pp. 29-30, 1985

<sup>158</sup> John et al., p. 213, 2008

<sup>159</sup> Hopp et al., p. 49, 2000

These assumptions have laid the foundation for the EOQ formula for calculating optimal batch sizes. The following notation was established:

$D$  = demand rate (units per year)

$c$  = unit production cost, not counting setup or inventory costs

$A$  = fixed setup cost to produce a batch

$h$  = holding cost (dollar per year an unit); for example

$h = c * i$ , where  $i$  is the annual interest rate

$Q$  = batch size (in units), which is the decision variable

These assumptions will result in an average inventory level of  $\frac{Q}{2}$ , therefore the associated holding cost for inventory is  $\frac{Q}{2}h$  per year and the setup cost  $A$  per order or  $\frac{D}{Q} * A$  per year. This leads to the cost expression for inventory, setup and production:

$$C(Q) = \frac{Q}{2} * h + \frac{D}{Q} * A + c * D.$$

Since the production cost does not depend on  $Q$ , the optimal batch size will be affected by the inventory and setups costs.

Taking the derivative of  $C(Q)$  yields the equation:  $\frac{h}{2} - \frac{AD}{Q^2} = 0$ , which represents the first-order condition of  $Q$  to be a minimum. By checking the second derivative it can be established that the zero slope corresponds to a minimum:  $2 \frac{AD}{Q^3} = 0$ . Since the second derivative will correspond to a positive value for any positive  $Q$  it can be established that the first derivative minimises  $C(Q)$ <sup>160</sup>.

Two useful equations can be established from this:

$$\text{Optimal batch size; } Q^* = \sqrt{\frac{2AD}{h}}$$

$$\begin{aligned} \text{Minimum holding cost and setup cost per demand; } C(Q^*) &= \frac{Q^*}{2}h + \frac{D}{Q^*}A \\ &= \sqrt{2ADh}^{161} \end{aligned}$$

### 3.5.4 Kanban

In a compromise between one-piece flow and push, one needs to have small stores of inventory between operations to make them run smoother. Since factories can be spread out over large areas, one needs a way to quickly signal that new stock is needed. That is where *Kanban* comes in. When speaking of Kanban one can broadly describe it as a signal of some sort. It could be a sign, doorplate, poster, cards, or whatever is needed to signal that a certain stock is running low and needs to be refilled with a specific amount.<sup>162</sup> The procedure starts when a kanban is passed down the line from the end process to signal stock is running low. The process down the line will produce the needed parts and then in turn send a kanban down the line to

<sup>160</sup> Hopp et al, pp. 50-51, 2000

<sup>161</sup> Ibid, p. 54

<sup>162</sup> Liker, p. 120, 2004

indicate it needs stock to produce more parts, and the process goes on in this manner through the processes until the first process gets a kanban, figure 3.12 shows an illustration of the two card kanban system. Since no production or movement of products can be done without being authorised by a kanban signal the end process sets the pace of the production and pulls from the other processes upstream<sup>163</sup>. It is a simple, effective, and visual system if implemented in the right way.<sup>164</sup>

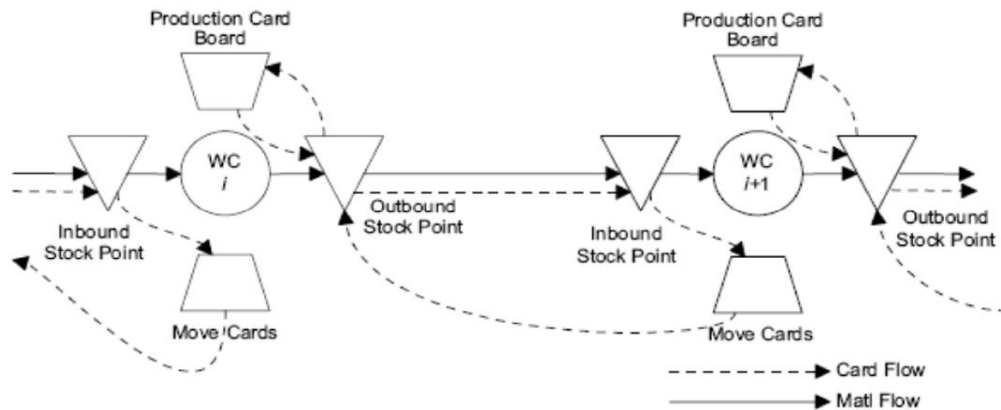

**Figure 3.12**<sup>165</sup> A classic two-card kanban system

### 3.5.5 5S

5S is a systematic tool that should be utilised in order to eliminate wastes that contribute to errors, defects, and injuries at the workplace. The 5S' form a continuous process of improving the workplace.<sup>166</sup> Participation and integration of all employees is needed to generate a sense of responsibility to succeed with a 5S program in the long run.<sup>167</sup> The reason to implement a 5S program is that people do many things without reflecting upon them, which can affect organisational productivity. According to Rowbotham, Galloway, and Azhashemi, if implemented right the 5S system can lead to<sup>168</sup>:

- The prevention of waste
- Better safety
- Improved efficiency
- The prevention of facility breakdown
- Improved quality
- Standardisation

<sup>163</sup> Rowbotham et al, pp. 265-267, 2007

<sup>164</sup> Liker, p. 120, 2004

<sup>165</sup> Marklund, 2012

<sup>166</sup> Liker, p. 165, 2004

<sup>167</sup> John et al., p. 208, 2008

<sup>168</sup> Rowbotham et al., p. 156, 2007

The 5S<sup>2</sup>, sort, straighten, shine, standardise, and sustain are described in more detail below:

- Sort
  - Sort through items and separate what is needed to perform value adding activities from what is never or seldom needed. Mark the rarely used items and remove them from the workplace.
- Straighten
  - Create permanent locations for each item that is needed to perform value added work, and arrange them in a descending order where the most frequent item used is easiest to reach.
- Shine
  - Make sure that everything stays clean every day. This process often acts as a form of inspection that exposes unusual conditions that could decrease quality or cause failures.<sup>169</sup>
- Standardise
  - Remove variations from the process.<sup>170</sup> Standards should be specific enough to be useful as guidelines, and general enough to provide some flexibility depending on the characteristics of work.<sup>171</sup>
- Sustain
  - The 5S mentality needs to be integrated into the everyday work and all processes.<sup>172</sup> Sustain is an ongoing process of continuous improvement to maintain the benefits of 5S. Audits by managers should be performed regularly, e.g. monthly. The companies that best sustain their 5S programs are the ones that conduct audits regularly.<sup>173</sup>

### 3.5.6 Value Stream Mapping

Value stream mapping (VSM) is a tool that helps one to see and understand the flow of material and information as a product passes through the value stream and it can be an effective visualisation of the shop floor to support lean manufacturing. A value stream is all the value and non-value added actions currently required to bring a product through the main flows essential to every product. This includes both the production flow from raw material all the way to the customer, and the design flow from concept to launch.<sup>174</sup>

For companies that want to plan, implement and improve a lean philosophy, VSM can be seen as the launch pad to begin identifying and improving a process family.<sup>175</sup> Graphic representation of the VSM is an easy way to learn a language that anyone in

---

<sup>169</sup> Liker, p. 165, 2004

<sup>170</sup> Rowbotham et al., p. 156, 2007

<sup>171</sup> Liker, p. 162, 2004

<sup>172</sup> John et al., p. 210, 2008

<sup>173</sup> Liker, p. 165, 2004

<sup>174</sup> Rother et al., p. 9, 1999

<sup>175</sup> Manos, p. 64, 2006

an organisation can understand and to instigate a willingness to change by decluttering all the processes of the non-essential activities.<sup>176</sup>

Implementing a VSM can be done on any level in an organisation. On a process level map one is looking at the flow in a departmental or interdepartmental level. Extending out to look at the whole facility is known as a facility level map. When mapping includes multiple plants, customers or suppliers, one is really starting to visualise the whole value chain, and this is known as an extended level map.<sup>177</sup>

Before the mapping process starts a process family has to be selected on which the VSM will be focused. Trying to draw all your product flow on one map is often too complicated, even for small companies. A process family is a group of products that pass through similar steps and equipment. An effective tool to help organise all the process families that exist in the company is a process family matrix, shown in figure 3.13 below, where equipment and assembly steps are on one axis, and the products on the other axis.<sup>178</sup> If a product goes through the processing step, place an X in the corresponding box. Go through all the products and look for those that share 80 % or more of the same process steps, these are considered part of the same process family. Choosing a process family can be difficult and by having some criteria to base your decisions on is always preferred. These can include:

- Biggest bang for the buck.
- Largest reduction in lead time or inventory.
- Biggest impact to the customer.
- Highest probability for success.
- Most visible to stakeholders.
- New product line.
- Volume or quantity.<sup>179</sup>

		Assembly Steps and Equipment							
		1	2	3	4	5	6	7	8
PRODUCTS	A	X	X	X		X	X		
	B	X	X	X	X	X	X		
	C	X	X	X		X	X	X	
	D		X	X	X			X	X
	E		X	X	X			X	X
	F	X		X		X	X	X	
	G	X		X		X	X	X	

**Figure 3.13**<sup>180</sup> Process Family Matrix

One starts of a VSM by carefully drawing, with pen and paper, a visual representation of every process in the material and information flow, known as “current state”. The next step is to ask a series of key questions, based on the information gathered for the

<sup>176</sup> Manos, p. 64, 2006

<sup>177</sup> Ibid, pp. 64-65

<sup>178</sup> Rother et al., p. 14, 1999

<sup>179</sup> Manos, pp. 66-67, 2006

<sup>180</sup> Rother et al, p. 14, 1999



“current state” map, and draw a “future state” map of how the value should flow.<sup>181</sup> These two mappings are done in an overlapping way, meaning that some ideas for the future state can be discovered through the current state mapping. Similarly, information overlooked on the current state map can be rediscovered when implementing the future state map. Lastly, an implementation plan is created that describes how the company plans to achieve the future state.<sup>182</sup> All steps described in the above text can be seen in figure 3.14.

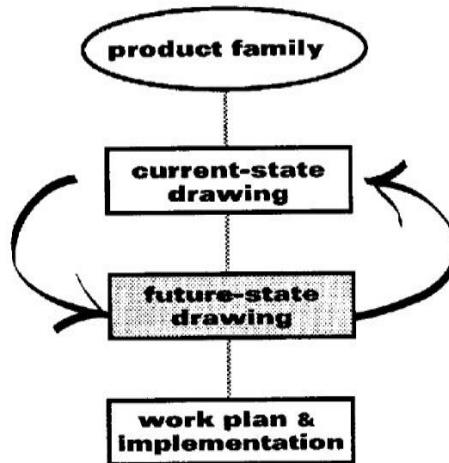

**Figure 3.14**<sup>183</sup> Initial Value Stream Mapping Steps

### 3.5.6.1 The Current-State Map

The equipment required to start the current state mapping is an A3 paper, a pencil and an eraser. Also, one will need to set the boundaries of the map.<sup>184</sup> It is best to start drawing the map at a factory level before drawing an extended or process level map. To gather the information needed, one needs to walk the flow himself or herself, preferably in teams larger than one person.<sup>185</sup>

Facts that should be collected, according to Manos, from walking the flow are information, such as:

- Cycle time or processing time.
- Changeover time.
- Reliability of equipment
- First pass yield.
- Quantities.
- Number of operators and shifts.
- Hardcopy information.
- Electronic information.

<sup>181</sup> Rother et al., p. 10, 1999

<sup>182</sup> Ibid, p. 17

<sup>183</sup> Rother et al., p. 17, 1999

<sup>184</sup> Rother et al., p. 12, 2009

<sup>185</sup> Manos, pp. 2,4, 2006

- Inventory levels.
- Queue or waiting times.<sup>186</sup>

When drawing the actual map itself using the icons explained in Appendix G some rules apply to get it right. For example, if an assembly process with connected stations would have some WIP inventory between the stations, the assembly should be drawn as a single process box. However, if the one assembly process is clearly disconnected from the next downstream assembly process, with WIP accumulating between them, then two process boxes should be drawn on the map. This rule applies in every situation where processes are distinctly disconnected from each other with WIP accumulating between them.<sup>187</sup> Inventory would be drawn with an inventory triangle, together with inventory lead time and amount.<sup>188</sup>

Material flow is drawn from left to right and information flow is drawn from right to left. The proper icon for each situation should be used, for example, if material is pushed downstream a striped arrow would be used,<sup>189</sup> see Appendix G for a detailed list of icons.

To complete the current state map, a timeline is drawn under the process boxes, clearly defining value-added time and non-value added time. By adding lead times through each process and through each inventory triangle in the material flow, a good estimate of the production lead time can be established together with the amount of value-added time and none value-added time.<sup>190</sup>

### 3.5.6.2 The Future-State Map

When the current state map is completed, a list of questions should be asked in order to identify opportunities of improvement, such as:

- What is the takt time?
- Are there bottlenecks or constraints?
- Where can inventory (or queue time) be reduced?
- Where can you improve flow?
- What other improvements are required?<sup>191</sup>
- What process improvements will be necessary?<sup>192</sup>

Based on the answers of the questions asked, ideas, thoughts and concepts should be marked on the current state map in red pencil. Once one has worked this out, the future state map can be drawn.<sup>193</sup>

---

<sup>186</sup> Manos, p. 4, 2006

<sup>187</sup> Rother et al., p. 14, 2009

<sup>188</sup> Ibid, p. 16

<sup>189</sup> Ibid, p. 23

<sup>190</sup> Ibid, p. 26

<sup>191</sup> Manos, pp. 5-6, 2006

<sup>192</sup> Rother et al., p. 50, 2009

<sup>193</sup> Ibid, p. 49

When drawing the map, place a kaizen burst, seen in Appendix G, around any item to signal improvement is needed. This may include low equipment reliability or first pass yield, long changeover times, large batches, or any waste such as overproduction, motion, transportation, waiting, defects or adjustments, and over or extra processing.<sup>194</sup>

### 3.5.6.3 Achieving the Future State

To actually execute the implementation plan is the most important step in the VSM. Without the implementation, all the company has done is create more *muda*, although it might have been an enlightening experience to map the value stream.<sup>195</sup> Looking at the future state map, the first question that usually arises is, “where do we start?” Firstly, one should try to break the implementation down into steps. Dividing the future state map into loops will achieve this. These loops can be seen as a series of connected flows for a family of products throughout value stream. Now the implementation plan is divided into a series of smaller implementation projects. By doing this, one can easier decide where to start. Choose by considering the following:

- Which process is well understood by your people?
- Where the likelihood of success is high (to build momentum)?
- Where you can predict high bang for the buck?<sup>196</sup>

One can then number the loops on the future state map in sequential order of implementation.

### 3.5.7 Evaluation Tools – Design for Assembly Method

The design process is an iterative, complex, decision-making engineering activity. There are several factors that need to be considered along with trade-offs throughout the design process. Factors such as performance, cost, reliability, and service tend to be highlighted; all while manufacturing and assembly costs tend to not get the same attention due to their difficulty to quantify. This poorly holistic design view will restrain the product from achieving its true potential. Techniques can be applied to reduce the impact of the poor design but redesigning it is not worth considering in this late stage as too much time and money has already been invested in justifying the design. Only when manufacture and assembly techniques are incorporated in the early design stages can quality and productivity be affected.<sup>197</sup>

In order to help integrate these into the design stages a tool is needed to analyse effectively the ease of assembly of the products or subassemblies. It should provide quick results and be easy to use. It should ensure consistency and completeness as well as eliminate subjectivity, enable easy comparison of alternative designs, and identify assembly problem areas. A feedback loop should be provided to aid designers and offer them a system to evaluate their own designs and, if possible, improve them. This should be done on the conceptual stage before too much time and money is invested.

---

<sup>194</sup> Manos, p. 6, 2006

<sup>195</sup> Manos, p. 69, 2006

<sup>196</sup> Rother et al., p. 111, 1999

<sup>197</sup> Boothroyd, pp. 219-220, 2005

Boothroyd states that the DFA method attempts this through:

1. Minimising the dependence of the design engineer on the support of the manufacturing engineer by providing much of the assembly information needed to design new products for “ease of assembly”.
2. Guiding the designer to simplify the product so that savings in both assembly costs and piece-parts costs can be realised.
3. Gathering information normally possessed by the experienced design engineer and arranging it, in a convenient way, for use by less experienced designers.
4. Establishing a database that consists of assembly times and costs factors for various design situations and production conditions.<sup>198</sup>

Through the DFA method several general design guidelines have been created to combine manufacturing knowledge and present to the designers in the form of rules to follow. These have been divided into two areas: handling, and insertion and fastening. Although these guidelines could be helpful, they are insufficient in the sense that: (1) they do not provide a mean by which to evaluate a design quantitatively for ease of assembly. (2) There is no relative ranking of all the guidelines that can be used by the designer to indicate which guidelines result in the greatest improvements in handling and assembly; there is no way to estimate the improvements resulting from the elimination of a part or from the redesign of a part for handling. (3) It does not provide the designer with an organised method that not only encourages the design of a product that is easy to assemble but also provide an estimate of how much easier it is to assemble one design, with certain handling and assembly features, than to assemble another design for different features.<sup>199</sup>

These problems were addressed by developing a systematic analytical method. This was done through experimental studies to measure the effects of symmetry, size, weight, thickness, and flexibility on manual handling time. Experiments were also conducted to quantify the effects of part thickness on the grasping and manipulation of a part using tweezers, the effects of spring geometry on handling time of helical compression springs, and the effect of weight on handling time for parts requiring two hands for grasping and manipulation. On the subject of design for manual insertion, analyses were done on the effect of chamfer design on manual insertion time, the design of parts to avoid jamming during assembly, the effect of part geometry on insertion time, and the effects of obstructed access and restricted vision on assembly operations. Based on the results of these studies, a classification and coding time standard system for manual handling, insertion, and fastening was presented. This was to be used by designers to estimate manual assembly times.<sup>200</sup>

The design efficiency, which is a key ingredient in the DFA method, was also created to measure the proposed design. The two main factors that influence the assembly time of a product are the total number of parts and the ease of handling, insertion, and

---

<sup>198</sup> Boothroyd, pp. 220-221, 2005

<sup>199</sup> Ibid, pp. 226-227

<sup>200</sup> Ibid, p. 227

fastening of the parts. The design efficiency is calculated by dividing the theoretical minimum assembly time by the actual assembly time. The equation is

$$E_{ma} = \frac{N_{min} * t_a}{t_{ma}}$$

where the  $N_{min}$  is the theoretical minimum number of parts,  $t_a$  is the basic assembly time for one part, and  $t_{ma}$  is the estimated time to complete the assembly of the actual product. The basic assembly time is the average assembly time for a part that presents no handling, insertion, or fastening difficulties. The theoretical minimum number of parts represents an ideal situation in which separate parts are combined into a single part unless, as each part is added to the assembly, one of the criteria, explained in chapter 3.3.2, is met. These criteria require the designer to consider if the product can be simplified, and it is through this process that enormous amounts of improvements in manufacturability and savings are achieved.<sup>201</sup>

It is also necessary for designers to be able to quantify the effects of changes in design plans in terms of assembly time and cost. Because of this need, the DFA method incorporates a system for estimating assembly time and cost that, together with part costs, can give the designer the information he/she needs to make appropriate trade-off decisions. The system is divided into Classification System for Manual Handling and Classification System for Manual Insertion and Fastening.<sup>202</sup>

---

<sup>201</sup> Boothroyd, pp. 229-230

<sup>202</sup> Ibid, p. 230



## 4 The Current State at Company A

*In this chapter of the thesis, a thorough description of Company A's production system and engineering department is provided as well as an overview of the market that Company A resides in. This chapter acts as the empirical part of the thesis and should provide the reader with the understanding on how activities are carried out at Company A.*

### 4.1 Market Overview

Company A is a lighting producer, offering both luminaries and lighting solutions to its customers, branding itself as a high end supplier focusing on quality. As a part of the Company B group, Company A can supply both locally manufactured luminaries and luminaries manufactured within the Company B group, enabling a wide range of products to its customers.

The main focus is to supply the local market of Australia within the market segments of indoor lighting solutions, outdoor lighting solutions, and retail lighting solutions. The Australian market highly appreciates locally manufactured products which have led to the Australian-made concept as a foundation for Company A to enable growth in the future. In addition to this, Company A is very customer driven, and is always trying to meet their customers' demands. Meeting their customers' demands include customisation of current products in any degree the customer is willing to pay for, and being flexible in lead times.

Reaching the market is handled by the external sales function, with its main objective to get Company A recommended in a project specification, proposing a luminary from Company A. The most important customer is the lighting engineer, who writes the specification e.g. for an office building project. However, there is no guarantee that Company A will get the order, this is just a proposal. In the following steps down the process there is a risk that a competitor will get the order. There are several factors influencing this such as the power position of the lighting engineer, customer loyalty and price of the luminaire. This is the nature of the market, but having the company name on the specification will greatly increase the chances for Company A to get the final order. Figure 4.1 shows the process from the start of a project to an actual order placed at Company A.

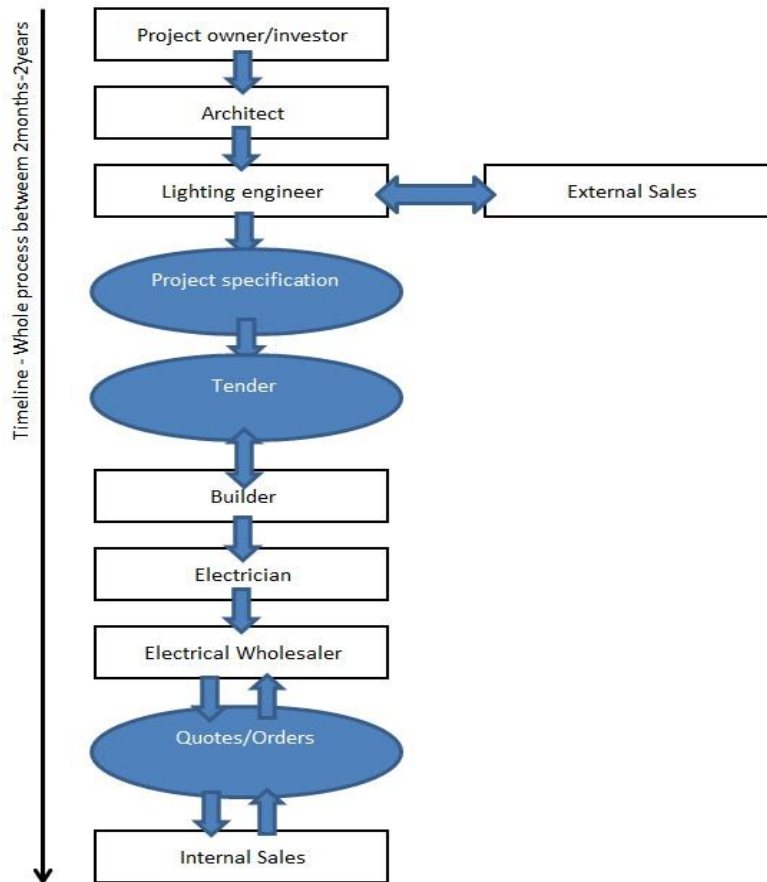

**Figure 4.1** Overview of the order intake

## 4.2 Production System

The production system at Company A can best be described as a push system because it is driven by customer orders in a make-to-order fashion. Some make-to-stock characteristics can also be observed. Inventory of semi-finished goods is kept in order to keep the efficiency of the production system as high as possible. Company A's customer driven market strategy, which results in a high product mix, makes forecasting of the demand difficult. The implications of this wide product mix along with an unpredictable forecast have concluded in their choice of having a make-to-order production system.

The customer orders that push the production system is managed by a production control system known as Material Resource Planning (MRP). Capacity planning is done by the Logistics Manager who plans the capacity at the assembly which is the controlling function of the production system. There are currently no data on processing times for the products in manufacturing, hence capacity planning is not conducted there. Two different schedules of orders, with a week apart, are created weekly for the production system by the MRP. This results in a general production lead-time of two weeks. These schedules are manually updated and prioritised on a



daily basis by production supervisors. Triggering orders to start is done solely by these supervisors. The schedules can be visually monitored by the production through two boards, one kept in the metal shop and one kept in the assembly. The metal shop consists of all the production processes except the paint shop and the assembly. The schedules are set a week apart, with the metal shop two weeks ahead of the delivery due dates and the assembly one week ahead, this to secure a high efficiency at the assembly line. Included on the schedules are Production ID, Item Number, Name, Quantity, Delivery Date, Allocation Time, Pool and Status.

#### 4.2.1 Manufacturing

The manufacturing function consists of two sub functions, the metal shop and the paint shop. In the metal shop one can identify three punchers, one roller, four folders, and four spot welders; the layout is shown in figure 4.2. The metal shop is the only function operating in two shifts, although with less manpower on the second shift. The layout is considered to be a functional layout.

The paint shop function is a one pace flow line consisting of four processes: washing, drying, painting and heating. It is manned by three operators. Fittings are hung with hooks onto the chain by one operator, completes its cycle, and taken off the line by a second operator. Quality checks are conducted by the third operator, adding paint manually if needed. One supervisor decides what to load onto the paint line; these decisions are taken in consensus with the assembly supervisor. The paint line has an average output of 500 parts per day.

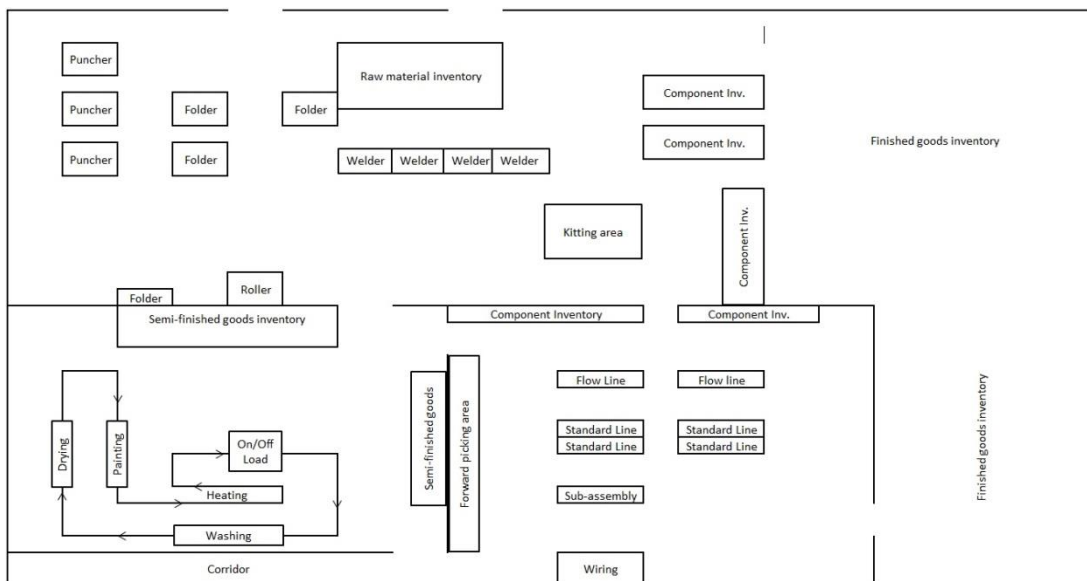

**Figure 4.2** Complete layout of the production system at Company A

#### 4.2.1.1 Incoming raw material

Deliveries for metal sheets could arrive any weekday. Incoming metal sheets are stacked on pallets and handled by the metal shop supervisor. There are 28 different varieties of metal sheets differing in size, thickness and type of material, which are all stored in the same inventory organised by size. Visualised in table 4.1 are common thicknesses, types of material and pack quantities delivered to Company A.

**Table 4.1** Summary of materials used and their thickness and pack sizes

Type of material	Thickness (mm)	Pack quantities
Aluminium sheet	2.0	80, 100, 114, 140, 150, 200
Chromium sheet	0.6, 0.8, 1.0, 1.2, 1.6	
Galvanised steel sheet	0.6, 0.8, 1.0, 1.6	

Quantities and that the correct type of material have been received is checked by comparing the information on the label attached to the pallets against the suppliers delivery docket when the supervisor is offloading the goods. However, the pallets are not opened and quality assured before they are stacked in the raw material inventory. Since it is not inspected, quality issues are not identified until the material is required. The most common defects are wavy sheets and obvious damages due to hard impacts on the material. When a changeover is due at one of the punchers the supervisor identifies the correct metal sheet by manually inspecting it. This is carried out, since the pallets with metal sheets are not labelled.

#### 4.2.1.2 Overproduction

Overproduction is embedded in the culture of the metal shop, founded on the belief that what is overproduced will eventually be consumed in the near future. However, growing inventories of semi-finished goods can be located at several locations within the manufacturing area, resulting in scarce space. This inventory will wait for whenever the next order of the same item is scheduled, a process that could take weeks, months, or even years. Adding to this is an unsystematic way of holding these buffers of semi-finished goods inventory (SFGI), with no system in place to register information of what is overproduced, where it is stored and what products to overproduce. Disorder is caused, and a lot of time is wasted when trying to locate an item since the information is stored in the individuals on the work floor, rather than in a supporting system.

A few reasons have been identified as to why overproduction is performed.

Example one: if an order consists of 38 fittings, the metal shop will usually produce a few more to assure that all the material is used instead of being scrapped. The drawings and CNC coding for the puncher for one metal sheet could be for six fittings. In order to produce the mentioned 38 fittings, seven sheets will be punched, resulting in a total of 42 fittings, which is four more than needed. These four overproduced fittings will go through all the value adding processes, and then held in

semi-finished goods inventory until next demand occurs or to cover for quality issues for another order; at this point it will be moved to final assembly.

Example two: Trial runs during setup are common in two processes: folding and rolling. These processes will often produce one, two, or three pieces of scrap depending on the complexity of the fitting. Depending on the first pass yield three different situations will unfold; some inventory might be added, just the right amount of fittings will be produced or an amount of lesser than the demanded will be produced. If less than the demanded is produced it might be covered by the SFGI or production of the needed amount is started.

Example three: Due to disorder of what is currently held in stock of semi-finished goods, a new job might be triggered, even though the demanded amount is held in stock. This phenomenon was observed by the authors when conducting the first VSM. The job followed was for 51 fittings where the supervisor triggered to start the whole batch at the punching process. When the job reached the paint line it was observed that 30 identical fittings were already held in semi-finished stock. These 30 fittings were painted with 21 of the 51 fittings followed, leaving the remaining fittings as semi-finished stock.

#### 4.2.1.3 The material and information flow

For every job that is triggered to start by the supervisor in the production, a production order is printed containing information such as; item number, type of product, order quantity, material consumption, and drawings for punching and folding. In addition to the mentioned information, a production order consist of multiple pages carrying bar codes that corresponds to the item numbers of the painted parts in the MRP system, page one is visualised in figure 4.3.

**Picking list** Page 1  
19/04/2013  
01:31:00 pm

Production .....: MPR062733      Reference number : MPR062732      Delivery date .....: 26/04/2013  
 BOM Item .....: S21740      Customer name ...:      Scheduled start ...: 12/04/2013  
 Reference type .....: Production line      Project .....:      Scheduled end ...: 26/04/2013  
 Started .....: 8.00      Specifier .....:      Picking list journal : MJN099084  
 Reported as finished :      Type .....:      Page: 1 of 1  
 BOM Name .....: PAINTED BODY AURORA LED ETB 600X600  
 Item name .....: PAINTED BODY AURORA LED ETB 600X600

Item number	Item name	Site	Location	Unit	In stock	Released	Proposal	Consumption	Picked
511501	CR 0.8 1400X1220 Quantity : 3.60 Site : DEF Location : SEMI-FG	DEF	SEMI-FG	EA	356.39		3.60	3.60	
510019	POWDER PEARL WHITE GLOSS Quantity : 0.55 Site : DEF Location : WIRING	DEF	WIRING	KG	1,124.95		0.55	0.55	

**Figure 4.3** Page one of a production order at Company A, showing the generated bar code for the specific painted part

This hardcopy information is supposed to follow the material flow through all the processes to support the operators with the needed operational information, this since there is no other form of labelling or information for the WIP. When the job reaches the paint shop a supervisor registers the material consumption into the MRP system and the hardcopy information flow for manufacturing ends, and is stored for a couple of weeks. Adding to this is a systematic approach of tracing the WIP, where the

supervisor, on a continuously basis, should update the system on what process the WIP is located.

However, from observations the described way is not always followed. WIP have been identified with no hardcopy information attached, the reason for this is that the hardcopy file holds process information for all the parts for the specific fitting, and in the case where all parts cannot be punched on the same metal sheet the job might be divided and completed in segments. An example of this is a fitting consisting of a frame, a body, and a gear tray. The body will be punched first, followed by the frame and gear tray. All the parts will not fit on the same load carrier resulting in the hardcopy being left at one load carrier with WIP, leaving the other WIP with no information attached. Also, the system is not regularly updated, which results in false information on where in the system the WIP is located. Furthermore, since the hardcopy information ends and is stored in the metal shop, no information at all is available in the paint shop in order to identify parts that come off the paint line.

The flow of WIP is solely a result of the push strategy, were inventory buffers are built up between processes. The level of WIP is continuously changing depending on the workload released into the system. On average, the highest levels of WIP have been located at the folding and paint shop processes.

#### 4.2.1.4 Organisation and structure

Throughout the metal shop focus is mainly on the process itself rather than a holistic view of how the workplace is run. Operators focus on the current batch and supervisor on supporting activities, leaving orderliness, structure, and development of standard procedures un-prioritised. However, there are some standard procedures and structure in place, such as throwing scrap in dedicated bins, an area dedicated as raw material inventory, tools are located next to their proper function, and a structured layout of the processes.

Due to the fact that orderliness is in a high degree discarded, space is getting scarce. From observation, load carriers carrying one or few items, even scrap, have been identified, yet voices are raised about space being scarce. This has turned into a situation where the workers try to do the best with the available space, instead of trying to disembarass wasted space.

As mentioned earlier, tools are dedicated to their proper function, but not necessarily organised in the dedicated area. The highest amounts of tools are found at the punching and folding machines, where a higher degree of structure in the dedicated tooling area is found at the folding process. A high amount of jigs and consumables have been identified in the welding area to support the welding process. It is common that tools and jigs that are used frequently are stored with ones that are rarely used, for example, in a bin. Some examples of how tools and jigs are stored in the metal shop are visualised in figure 4.4.



**Figure 4.4** Some worst case examples how tools and jigs are stored in the metal shop

When a job is finished at one process the pallet is placed as close as possible to the next process downstream. As long as the system is not too congested, the pallet will be placed at a reasonable location in order for the next process' operator to be able to locate it. However, when the system is congested, the pallet might be placed closer to a further downstream process which causes confusion. An example of this was observed when a pallet of WIP, currently waiting to be processed at the welding station, was considered ready for painting since the pallet was placed amongst the WIP ready to be painted, and was therefore moved into the paint shop.

In the paint shop one can identify a higher degree of standardised procedures, due to the reason of the paint shop being shut down one day a week. During this day the three operators clean all the chambers of the paint line's processes, clean the paint shop, and try to disembarass wasted space if there is additional time. However, no attempt is made to organise the earlier mentioned semi-finished goods inventory in chapter 4.2.1.2, which is located and stored in racks at the paint shop.

#### 4.2.1.5 Setups

The general strategy at Company A is to batch jobs of the same fitting in order to reduce setup times. The current trend is a reducing average batch size, which has been a trend for a couple of years due to the nature of the market demanding a large product range. The weekly schedule is sorted by item numbers with a corresponding product name and jobs will be batched accordingly. In what order the batched jobs will be triggered to start is not dependent on the sorting of the weekly schedule, rather

according to if the next batched job to start will require the same metal sheet and/or the same tooling. Although, it is not unusual that this planning is interrupted by jobs that might have been rescheduled in the master planning, or jobs that are urgent. The supervisors are the ones responsible for setups. In table 4.2 each process' setup is explained in more detail.

**Table 4.2** Elements of the setups at each process

Process	Internal Setup	External Setup	Preparation	Tooling change	Adjustment	Trial runs
<b>Punching</b>	X	X	X	X		
<b>Folding</b>	X	X	X	X	X	X
<b>Rolling</b>	X	X	X	X	X	X
<b>Welding</b>		X	X			
<b>Painting</b>	X	X	X			
<b>Sub Assembly</b>		X	X			

Two of the processes do not consist of an internal setup time. However, observations show that external setup is not always conducted when the process is still active, a fact that is true for all the processes. Supervisors who are responsible for setups are often executing other activities as well, which is one of the reasons for the delays in external setup. Another reason is poor communication between the operators and supervisors, not indicating or identifying early enough that the current job is about to be completed. In other words, external setups are handled as internal setup on a regular basis, even though the knowledge that it can be handled externally is there.

From observations, the punching, folding, and rolling processes' setups have been of higher interest since they include most of the elements of a setup. The observed setups are explained in more detail below.

A complete setup for the puncher includes the following: change of metal sheets, tooling change, moving completed job to the next downstream process, setup new load carrier for stacking punched material, and loading next CNC program. Currently, change of metal sheets and tooling change are done as internal setup, while the other elements are done externally in a varying manner as previously explained.

A complete setup for the form roller will include the following: locating and ergonomically fixating of load carrier of WIP, tooling change, trial runs, and re-adjustments. Since the form rolling machine is a long-standing machine, the fixating of tools is handled manually. This manually handled setup will always be subject to variations, therefore incurring trial runs in order to get the proper result from the process. The only aid for the setup is markings on the tools on where they should be placed. The result being a procedure of trail run, re-adjustment, trail run, re-

adjustment, and so on until the desired result have been achieved. Obviously, every setup's first pass yield will depend on how off the first trail run is. Also, since there is no standard procedure on how to setup the machine, it heavily relies on the competence and experience of one or two supervisors.

A complete setup for the folder includes the following: locating and ergonomically fixating the load carrier of WIP, tooling change, loading CNC program, trial runs, and re-adjustments. The root cause of trail runs is the lack of standardised folding instructions and visual aid in combination with varying thickness of the metal sheets compared to the specified thickness. Folding instructions are often hand drawn, resulting in the need to manually adjust the CNC parameters after the first trail run. However, the adjusted parameters are not fed back to the CNC designer. Depending on the complexity of the fitting the number of trail runs will vary. Observations and interviews show that it is common that at least one trial run is necessary. Folding is also considered to be a form of craftsmanship, resulting in that some fittings might only be processed by experienced employees. These experienced employees are often the supervisors.

#### 4.2.1.6 Quality

Quality issues mainly arise at two processes, folding and rolling, due to the trail runs mentioned in chapter 4.2.1.5. The result of these quality issues are more than often hidden by overproduced parts, meaning that it is not visualised in downstream processes until in the assembly, when an order is picked and the quantities does not match the order.

Quality issues that occur at the punching process are due to tools breaking, tools being worn out, and incorrectly setup jobs. These however, are not issues that occur often and will be dealt with on spot if they do occur, hence eliminating downstream issues.

#### 4.2.1.7 Capacity

Interviews and observations have shown that the processes of punching, rolling, and painting have excess capacity, while welding are at near capacity, and folding is considered to be the bottleneck. All fittings go through punching and folding processes, since the punching process is automated with standardised CNC programs for all fittings, throughput is high. This cannot be said for the folding process, described in chapter 4.2.1.5, where more manual work is needed as well as each part is required to be processed individually, while in the punching process one operation can generate several parts. Also, due to the high degree of automation at the punching process, it has been observed that the operator is unutilised for several minutes per cycle simply waiting for the machine to finish its cycle time. This waiting time will differ depending on what parts that are punched.

### 4.2.2 *The Assembly Function*

The assembly function consists of six assembly lines, where two of them are flow lines and four are standard, and two sub-assembly tables. Each assembly line holds four stations and is usually manned by three or four operators depending on the job



being assembled. It is supported by a wiring function, a quality inspector, two pickers, a supervisor and the production manager. The layout is visualised in figure 4.2.

#### 4.2.2.1 Assembly lines

Flow lines in the assembly are arranged with one LCD-screen for each station, with instructions on how to assemble the current job, serving as a visual aid. A total of 15 consumables and components are placed in bins of two and located at the flow lines. The bins are refilled twice a day by a supporting operator. These items are deemed to be standard for a wide range of products, hence the decision to keep those specific ones at the assembly lines. The workbenches can be moved horizontally and are pushed downstream to the next station when the operations have been completed at the current. Originally, these flow lines were arranged to assemble a predetermined group of fittings, that were deemed suitable for flow line assembly. However from observations and interviews, the flow lines are not living up to their potential. With a large product mix and an inconsistency of what fittings are being assembled at the flow lines, the supporting instructions for the visual aid are insufficient. It is more likely that the visual aid is not being utilised at all.

The other assembly lines are standard workbenches where the WIP is moved manually from station to station with no visual aid supporting the operator. Generalisation of the assembly operations will result in five main operations that can be counted for when a fitting is assembled: assembly of the gear tray, assembly of gear tray and body, insertion of lamps, testing and packaging. The sub-assembly tables are typically utilised to assemble frames with diffusors but also for other various activities. They are manned by one operator on each table.

From observing fittings being assembled, the highest amounts of tools were used when assembling a gear tray and the second highest when mounting a gear tray and body. Except for screwdrivers hanging from a predetermined location no other tools have set locations. This causes a situation where employees might have to go and look for missing tools during a setup. It also happens that there are insufficient tools at certain times since there is no awareness on the total amounts for a specific tool due to the disorganisation.

In order to reduce the repetitively of tasks and to increase the knowledge and skills of the worker, stations are swapped cyclically every two hours. When an operator is placed at a station he or she might not be familiar with, efficiency is reduced and quality issues might increase. However, from observations one could notice that the operators' skillsets are great and if issues occur at a station due to upstream events, it can be handled by the stations operator rather than being too dependent on one or a few skilled operators. This, since the team will help each other out and share knowledge in order to prevent the same mistakes arising again.

#### 4.2.2.2 Planning

The overall scheduling has been described in chapter 4.2. In addition to this, there is some internal scheduling within the assembly function. Morning meetings are conducted every day, consisting of the supervisors from the Metal Shop (MS), Paint Shop (PS) and Assembly, the picker, and the production manager, where daily



planning for the assembly function is conducted. The reason to involve the MS and PS supervisors is due to the fact that they act as supporting functions to the assembly and need to be updated on a daily basis. On the weekly schedule all due dates are set for the coming Friday and will be delivered as soon as possible after completion or the following week.

Batching is also the strategy in the assembly, where orders for the same fitting are batched and completed as a whole.

Since capacity planning is done for the assembly, as described in chapter 4.2, assembly times have been allocated for all fittings. These times have been produced from general assumptions and experience. However, when an assembly job starts data is collected on when the job started, when it is finished, and the quantities of the job in an attempt to get more accurate assembly times.

In order for Company A to meet their due dates, when planning have been insufficient or various issues have decreased productivity, overtime and temporary staff is utilised.

#### 4.2.2.3 Material supply

There are a couple of support functions and a few employees supplying the assembly lines with material. The paint shop function is the link between the metal shop and the assembly function, where the supervisor's main responsibility is to assure that the parts the assembly stations require are available for picking. In addition to this, the supervisor also has some responsibility of kitting jobs.

Within the assembly function, the supervisor has the responsibility to organise the setups of jobs, making sure that when a job is finished there is already a kitted job ready to be processed, as well as managing the assembly lines, dealing with issues that arise. There is also one dedicated picker with the sole responsibility of kitting.

A setup in the assembly mainly consists of preparation. Preparation is considered to be an internal setup when it is not carried out when an assembly line is active. Preparation includes kitting, cutting wires, placing the kitted pallet at the line, replenishment of consumables and components, and giving instructions for the job. In table 4.3 the elements of a setup can be seen. Even though operators are not supposed to replenish anything, observations have shown that power cords and packaging is often replenished by the operators during a job.

**Table 4.3** Elements of a setup in the assembly

Process	Internal Setup	External Setup	Preparation	Tooling change	Adjustment	Trial runs
<b>Assembly</b>	X	X	X			

The wiring function consists of a wire cutter machine that is manned by one operator. At the end of the week, Thursday and Friday, the wiring function is manned by the operator. A list of labels for the following week's orders to assemble is printed and

supplied to the operator by the product manager. With the aid of a database, information on what wires and lengths are needed for a specific fitting is obtained. The objective is to cut all the wires needed for the orders of the following week. The information in the data base is obtained by scanning the bar code on the label. The cut wires are stored in bins with the labels attached. The labels share visual information on:

- Production number
- Item number
- Product name
- Quantity
- Delivery date

Kitting is done by the picker who is supported by a picking list. The information provided on the picking list is described below and visualised in figure 4.5:

- Item number
- Item name
- Site
- Location
- Unit
- In stock
- Proposal
- Consumption
- Boxes to tick when an item have been picked

**Picking list**

Production .....: MPRO61749  
 BOM Item .....: EL-XT5-228-202-400  
 Reference type .....: Sales order  
 Started .....: 2.00  
 Reported as finished :  
 BOM Name .....: 2X28W PC XT5 Y5 1200X250 FTB  
 Item name .....: 2X28W PC XT5 Y5 1200X250 FTB

Reference number : SOR012893  
 Customer name :  
 Project :  
 Specifier :  
 Type : M2/P

Delivery date .....: 08/03/2013  
 Scheduled start ..: 08/03/2013  
 Scheduled end ...: 08/03/2013  
 Picking list journal : MJN095235  
 Page: 1 of 1

Item number	Item name	Site	Location	Unit	In stock	Released	Proposal	Consumption	Picked
510004	BALLAST PC 2X14-35 T5 PRO LP	DEF	Z-01-A-03	EA	715.00		2.00	2.00	
510007	LAMP HOLDER T5 ST285/FAU +L+	DEF	Z-03-B-02	EA	13,876.00		4.00	4.00	
520167	LAMP HOLDER G5 END FIXING RED LEVER BJB	DEF	Z-03-B-07	ea	915.00		4.00	4.00	
519960	TERMINAL BLOCK 3 POLE WAGO DIRECT EARTH +L+	DEF	Z-04-B-02	ea	4,242.00		2.00	2.00	
510010	FLEX & PLUG L=2000 MM	DEF	WIRING	EA	2,777.00		2.00	2.00	
510002	CORD GRIP MEDIUM BLACK HP&N-4 +L+	DEF	WIRING	EA	7,010.00		2.00	2.00	
519660	DIFFUSER Y5 1155X197	DEF	WIRING	ea	32.00		2.00	2.00	
519010	TERMINAL BLOCK FUSED ST685/A	DEF	Z-04-C-02	ea	2,922.00		2.00	2.00	
511207	FUSE 2AMP CERAMIC 5X20MM - FT02ACE	DEF	WIRING	EA	3,289.00		2.00	2.00	
519582	PAINTED BODY XT5 1200X250 TWIN LAMP PC	DEF	SEMI-FG	ea	13.00		2.00	2.00	

**Figure 4.5** A standard pick list in the assembly function

The picker picks all the components needed for the job on a load carrier which is then placed at the dedicated picking area or in the paint shop, visualised in figure 4.2, until

it is needed by the assembly line. However, when kitting, the picker is supported with insufficient information. The supporting warehouse management system (WMS) in place at Company A can handle dedicated storage locations but not dynamic. This means that if a storage location is empty, it can only be replenished with the item that is dedicated to it. Dedicated storage locations are only set for four racks within the site, containing frequently used components. This is considered to be a forward picking area. The remaining items to be picked have no set locations and the picker have to locate them from memory, communication with other employees, or by fumbling in the dark. Examples of this is the semi-finished goods inventory explained in chapter 4.2.1.2 and the fact that parts that come off the paint line have no information attached to them further explained in chapter 4.2.1.3. This situation causes setup delays and standstill in the assembly line due to wrongly kitted items and an insufficient kitted number of jobs. Also, supervisors spend time helping the pickers to locate components instead of managing the assembly lines.

#### 4.2.2.4 Quality testing

Quality testing is done by the quality inspector in the assembly function. This is a more in-depth testing procedure than the testing on the assembly line, which is only a test to check if the lamps light up. Testing is done on earth, polarity, resistivity and leakage to ensure that the fitting meets industry standards and regulations. The test is done for every batch that goes through the assembly function but only for a couple of fittings of the batch.

### 4.3 Product Development

#### 4.3.1 Stage gate model

The Company A Project System (CPS) can best be described as a Stage-Gate model modified to support Company A's product development department. It was implemented via request from the department after a realisation that development projects were spanning over too long periods and deadlines were hardly met. Considering Company A's customer oriented product strategy, the CPS is not followed strictly to the letter but more in the sense as a guideline to give structure to their work process, a so called "road map". It is utilised in a flexible manner both for redevelopment project and for new development projects, adjusted accordingly to the urgency or size of the project. This is done to avoid that the work process gets bureaucratically bogged down. A redevelopment project may, for instance, not have the same restrictions as a new development project, to make the process more streamlined. There are, however, occasions when the CPS is disregarded fully: when a product modification is being done, the department has neither the resources nor the personnel to follow the model, considering that usually over a 100 modifications could be done in a month, and it is thus overlooked. The CPS gives the designers a set time frame to focus all the creative thinking into and to explore all possible issues that may arise in further stages.

The CPS consists of six stages followed by six gates, each with the purpose to ensure that tasks are performed accordingly. Gates are only to be opened if their criteria are fulfilled and only the Steering committee, consisting of senior managers, has

authority to open them. The Steering committee has the overall responsibility of the projects budget, resources, time plans and approvals. For each project a project manager is also assigned who is responsible for, among others that the project runs in accordance with the CPS.

Before the project start, a Pre-study (stage one) is conducted, which can be classified as a project in itself. Included in this are target costs, product launch date, and recommendations on materials, quality, and finish. If all the criteria are covered then Gate-1 (gate one) is opened and the project is initialised.

The project starts off with the Planning stage, where tasks such as project members and resources are finalised, a time plan is developed, and goal costs are decided. This is followed by the Design stage, where tests are performed and the product drawings are completed. The next stage is Tooling. Included in this stage is approval of all samples, schedule time for the trial and 1-series in manufacturing, a demonstration and an information meeting with production is held. Preparation follows Tooling and is the stage where components are made sure to be in stock, all codes and BOM's are complete, and external samples/components are quality checked. The final stage is Trial Production which includes finalising the drawings, the trial production is performed and checked by the project group, and all the departments have agreed that the production is ready. At the end of a project a product evaluation is performed where the budget, timeline, and areas of improvements are assessed.

#### *4.3.2 Design for manufacturing and assembly*

DFMA is a very important aspect for the designers at Company A. Because of the small scale of the department and the close interaction between production and design, this is practically implemented into the work process. During the conceptual phase of the design the product developers try to consider what tooling is going to be used for producing the product and if some tooling process is preferable to others. Also, because of their integrated department structure, with the factory door-to-door to the office, they can quickly receive feedback on their designs. This close link to the production enables the designers to effectively handle trial runs and the creation of prototypes.

A sense of ownership for the product being developed is always considered in order for the employees to take pride in what they are creating. Involving everyone into the project in the early stages and throughout the development is done to improve this sense of pride. The engineering manager deems that this early and consistent involvement assures that DFMA is maintained, as it will increase the likelihood of important input from the production.

Through the engineering manager's experience and good understanding together with the production manager, the assembly process is thoroughly planned. The design is thoroughly considered in order to work well at all the stations along the assembly line. A sample is created and examined early in the development phases and reassessments are made throughout the development process with new samples. Having the managers assemble the product to understand the process with hands-on

learning and timing it to calculate the ideal assembly time allows them to make an appropriate analysis.

Having said this, the engineering manager admits that the development process is a work-in-progress and that improvements in applying the DFMA methodology can always be made. The product design can be improved to speed up the production but the department is already pressured with a wide workload. The resources are not available to spend a few weeks on developing a snap fitting or other alternatives to speed up assembly. Also, through observations and participation by the authors in the assembly, consumables have been found to be problematic. There is a big variety of consumables used to assemble a fitting and between different fittings, which increases handling time and the risk of using the wrong consumable. In addition to this, difficulties in locating, positioning, and fastening the consumable were noted: consumables are dropped, hard to manoeuvre, can be fastened wrong, and could damage the fitting. Some assembly processes involving consumables were observed to require a high degree of dexterity from the employee due to part and consumable handling and fastening having to be done almost simultaneously. In our case, when observing this situation, two employees had to work together to decrease the risk of lowering the throughput on the assembly line. Time is also needed to restock the assembly lines with consumables and this could cause a standstill in the flow if not addressed appropriately.

#### *4.3.3 Standardisation*

Standardisation is considered early in the development process and it is maintained largely through the use of the gates in the Stage-Gate model. Standardisation is an important aspect, according to the engineering manager, in order to support the product development department. It enables a lot of the work to be streamlined with fewer hold ups caused by uncertainties since certain standards are set and thus allows them to focus on the creative parts of the development processes.

Standard components are utilised over their entire product range where unique parts or components are utilised very rarely. They try not to be dependable on only one supplier for every component, but have at least two in order to ensure production efficiency and stability without risking the integrity of the fitting. This can only be done through component standardisation as well as dimension and footprint standardisation that are formed to match several suppliers. They strive for component placement and dimension standardisation to ensure that a consistent part dimension or geometry can be used in as many products as possible i.e. the length of wires. The department uses CAD to help maintain set standards on all products. Every drawn component is stored onto the company network for easy access. Drawings used in product modifications can thus be systematically updated and restored.

The ideal standardisation level, however, is not fully implemented on all products because of the lack of time and resources.

#### *4.3.4 Modularity*

Company A tries to maintain a high degree of modularity in order to help keep a large product mix in an effective way. A certain body could be fitted with several different

lamp types and several numbers of lamp rows. The body can also be fitted with different diffusers and reflectors without compromising the integrity of the fitting. The gear tray, which is mounted onto the body, also has a high degree of modularity with different ballast combinations and terminal blocks available. The body and the gear tray serve as the platforms of the fitting with a slot sub-type architecture, explained in chapter 3.3.3, and enables the products to have a large degree of variation, without having to increase the workload for the product developers. Figure 4.6 shows the various different combinations of diffusers, terminal blocks, and downlight accessories that are available for a fitting. Commonality is maintained by utilising the same gear tray to several bodies. Many of the product variations offered by Company A in their product mix are visually noticed in the later part of the production process, usually in the assembly. This is done in order to relieve manufacturing from having to tackle the complications associated with having a large product assortment that is offered by Company A.

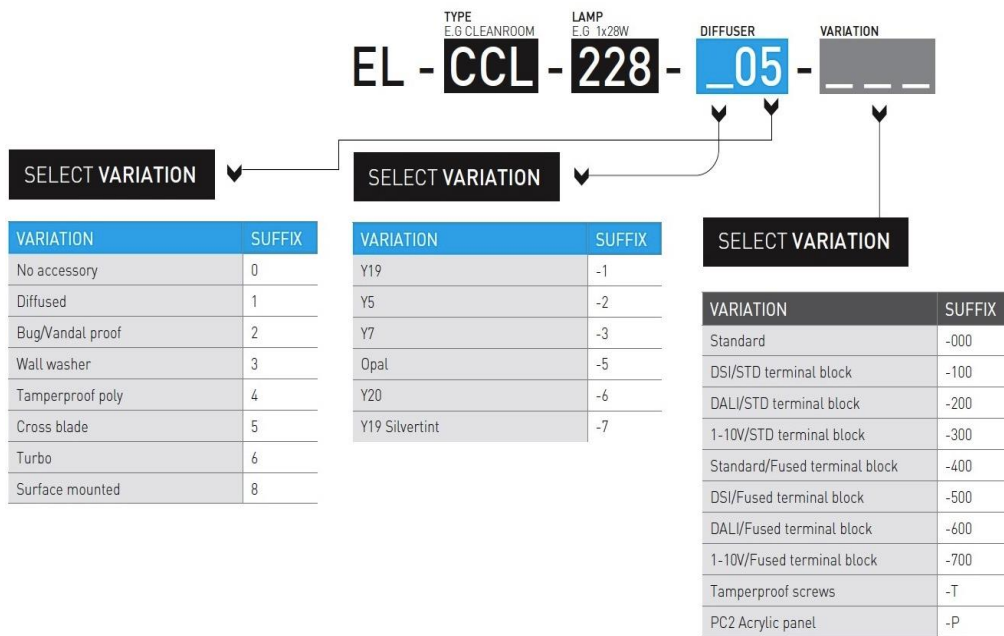

**Figure 4.6** Product Variation Diagram

In some fittings, a modularity design is offered on a product-to-product level rather than on a component-to-component. These fittings can be connected through a sectional sub-type architecture where the first and last are compatible with multiple in-between fittings through an identical interface, seen in figure 4.7 below. This gives the fittings a continuous, undisruptive design when connected. These sectional fittings can also be modified to include sections with no light sources and thus provide the desired light distribution. The assembly of these fittings would on the other hand be done on site and not at Company A.

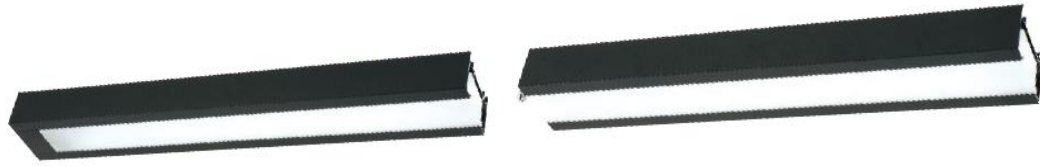

**Figure 4.7** Continuous Module Lamps

A major redevelopment project that is ongoing at Company A is the change from a fluorescent light source to LED although it is still in its pre-study phase. This project will involve almost all their fittings that have fluorescent lights and as such could burden the product development department substantially. But, because of their modular product design, only certain components will have to be redesigned instead of the entire fitting, which would probably have been unmanageable by the product development department, considering its size. Switching to LED does however lead to complications in maintaining the same light distribution curve and could require changes in the design of the fitting.

No set strategy in maintaining modularity, through the use of commonality or differentiation, has been noted at the company. Instead, the designers implement modularity in a natural manner in their development process and through the use of mental checklists.

#### *4.3.5 Evaluation*

Certain evaluations are conducted within the product development department. These are mostly associated with the gate meetings where the project managers and directors discuss the project and the necessary adjustments needed to allow the project to proceed onto the next stage. This allows evaluations to be made at important key events in the project. In addition, a project evaluation is performed closed to the end of the project where packaging, installation, technology, maintenance, and aesthetic are assessed. A final overall project evaluation form is lastly filled out where the set budget, the timeline and possible improvements are evaluated.

During the design stage, however, no evaluation tool is used but would be deemed useful according to the engineering manager; a checklist of some kind to validate that all appropriate points have been covered concerning standardisation, modularity, and DFMA. Many of the tasks assigned to the product development department concern cost calculations and estimations for new products and modifications. Time studies have been performed in the production to help with these costs but it is more difficult to perform accurate time studies on the assembly process due to large variation in required assembly steps depending on the product and due to the human factor involved. A theoretical evaluation tool for the assembly process could therefore be a valuable asset to relieve the department of some of the bureaucratic hassle involved in formulating these costs.





## 5 The Current State Analysis

*The authors will provide the reader with an extensive analysis of the current state at Company A, resulting in identified gaps. The analysis is conducted by comparing the current state to the established frame of reference in order to identify gaps between the two.*

### 5.1 Production System

To start the journey of becoming lean in operations, continuous flow should be created wherever applicable, striving for the ideal of a one-piece flow as explained in chapter 3.4.2.2. This should result in a pull system with zero or small buffers of inventory between processes. However, in a make-to-order environment with a high variety of products it would be difficult to implement a pull system and the results could be higher finished goods inventory levels with no efficiency gains. Adding to the complexity is the insufficient data on processing times for each product in manufacturing, chapter 4.2, which will make it impossible to even out the workload. To even out the workload is essential in order to become Lean, further described in chapter 3.4.2.2. The verdict is that Company A is not mature enough to implement a full scale pull system yet.

Instead, their chosen strategy of a make-to-order approach is considered to be the most suitable approach for Company A. This since there is a wide product range, making forecasting very hard, as described in chapter 4.2. Their choice correlates well with the theory in, chapter 3.2, describing that when a final product has a high degree of variation a MTO approach is suitable. Since work released into the system is based on demand, the production system is a push system as described by definition one in chapter 3.2, and further supported by definition two, since there is no WIP cap utilised at Company A. However, implementing continuous flow where it is suitable and start a project of mapping processing times in manufacturing could set a foundation for the next step of becoming Lean. In addition to this, with data on processing times, Company A would be able to determine a WIP cap that would allow processes to be utilised to their capacity and at the same time lower inventory levels and increase flow. A way to put a cap on WIPs is the Kanban system, explained in chapter 3.5.4, where a set level of cards will limit the workload released into the system at any given time.

The production system is aligned with the sales department. There is a high product mix which is within the range of what is suitable for the process choice of batching, explained in chapter 3.2.1, and the numbers of orders obviously vary but will fit in the

middle bracket. It is fair to say that the sales department and production strive for the same goal, which is to fulfil their customers' demands, see chapter 4.1. Illustrated in figure 5.1 below is the positioning of Company A in Hill's process choice model.

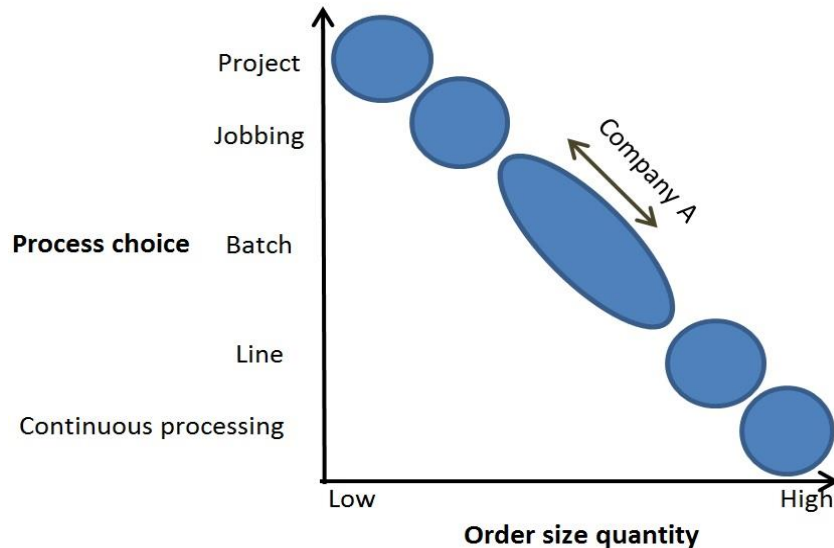

**Figure 5.1** The authors positioning of Company A in Hill's process choice model

The spread represents a varying order intake volume. However, its variance will be aligned with the process choice of batching at all times since the order volume will not be high enough in order to dedicate processes to a specific product or product range which would be considered a line process, further described in chapter 3.2.1. Nevertheless the high product mix puts pressure on reducing downtime due to setups, which is further analysed in chapter 5.1.1.5.

There are concerns though; the product mix is constantly growing which will induce more pressure on the production system in the future. In order for Company A to avoid drifting into a mismatch between the sales department and the production in the future, there needs to be a sense of caution when expanding the product range. Company A needs to continuously improve the production system to assure that it can handle the expanding product range specially in terms of flexibility and efficiency.

### 5.1.1 Manufacturing

#### 5.1.1.1 Incoming raw material

The inspection of incoming raw material is insufficient at best. As described in chapter 4.2.1.1, only quantities and that the right material is delivered is checked, leaving quality assurance ignored. This results in three of the eight kinds of waste according to Liker, chapter 3.4.4, which are unnecessary transport, unnecessary movement and possible defects in downstream processes. Adding to the above-mentioned wastes is the fact that the load carriers containing raw material are not labelled which forces the employee to identify the correct material manually.

Best case scenario for the current state is that quality issues are identified at the raw material inventory, if the pallet is opened there before it is moved to the punching process. Opposite to this is the worst case scenario where the quality issues are not identified until in downstream processes, creating all three kinds of waste stated above. Adding to this, is the situation that occurred during the VSM, Appendix I, where the raw material that was required for the job was defect and that quantity was also the last of that specific material. This induced waste since that job was held up waiting for the next delivery of raw material.

In the case that quality inspection is done when the raw material is delivered, it will prevent the earlier mentioned kinds of waste. An inbound logistics management system (ILMS) needs to be developed, in order to assure quality and delivery conformance and to evaluate supplier performance. This will enable Company A to continuously improve relations and performance of their suppliers.

#### 5.1.1.2 Overproduction

According to Lean, overproduction is considered the fundamental kind of waste since it causes most of the other wastes, see chapter 3.4.4. At Company A, overproduction is a major issue both in reality and according to theory, resulting in space getting scarce, high scrap rates, high inventory levels, increased lead times, tied up capital and hiding quality problems. As described in chapter 4.2.1.2, overproduction is embedded in the culture of the metal shop where a few examples are stated when it occurs. Un-systematic overproduction must be considered a waste by all employees in order for a cultural change to take place, a change that must come from a senior director's directive. The directive to stop overproduction will enable the development of employees and the improvement of processes since issues will be visualised. As described in chapter 3.4.2.2, the company has to build a culture of getting quality right the first time and to stop to fix problems. This needs to be done, so that countermeasures can be developed for the visualised issues, and to set standards to enable continuous improvement. However, changing a company's culture takes time and will need the long-term commitment of management in order to be successful the Lean way, see chapter 3.4.2.1.

According to Lean chapter 3.4.2.2, some inventory buffers are allowed but in a controlled manner. As described in chapter 4.2.1.2, Company A utilises buffers of semi-finished goods in a very unsystematic way. These buffers serve the strategic purpose of reducing setups in order to keep efficiency high, chapter 4.2. However, in reality its function has evolved to cover for quality losses in upstream processes that should have been visualised in final assembly, examples can be seen in Appendix I, chapter 4.2.1.6 and chapter 4.2.1.2. These buffers of semi-finished goods should serve the purposes of reducing the number of setups, decreasing lead-times, reducing scrap rates and increase picking efficiency. For this to be manageable a systematic way of holding semi-finished goods inventory needs to be developed, where only parts and quantities that can be argued for is allowed to be held in stock. A set standard on what parts to hold and procedures on how to manage it needs to be established to sustain order in the semi-finished goods inventory.

#### 5.1.1.3 The material and information flow

The interaction between material and information flow is not functioning very well. The current system is only suited for the situations where a job is not split into more than one load carrier as described in chapter 4.2.1.3. Adding to further complications is the fact that a hardcopy file can easily be misplaced or get lost since it is not permanently attached to the pallet. Even though there is a system in place for locating at what process the job is, one still has to locate the load carrier for the job in that area which can be time consuming if no information is attached. Also, since this system is not accurately updated it could even induce more confusion by directing the employee to look in the wrong area to begin with.

Stated in chapter 3.4.2.2, the implementation of a visual control system could; increase productivity, reduce defects and mistakes, facilitate communication and give the worker better control of their environment. These are all aspects that need to be improved in manufacturing at Company A. Also, the system should act as a support for the employees and new technologies should be thoroughly tested and analysed to enable a smooth implementation as explained in chapter 3.4.2.2. The need for a good visual control system to identify the WIP is great since a lot of time is wasted trying to locate WIP. Also, it would reduce the mistakes that occur due to confusion and faulty communication.

#### 5.1.1.4 Organisation and structure

There is no culture in believing that it is important to keep a clean, organised and structured workshop environment within the manufacturing function. This is described in chapter 4.2.1.4, where focus is on the process, ignoring orderliness, structure and development of standard procedures. Neither is there a system nor standards in place to support the employees to keep a clean workshop. There is an urgent need to change this way of thinking. A tool that should be utilised, in order to increase organisational productivity, is the 5S system, explained in chapter 3.5.5. If implemented and practiced appropriately it could induce improvements such as:

- The prevention of waste;
- better safety;
- improved efficiency;
- the prevention of facility breakdown;
- improved quality;
- standardisation.

The earlier described situation in chapter 5.1.1.3, where no effective system is in place to trace WIP, further induces the need of a clean and organised workshop environment since WIP is located and identified visually by walking around looking for it, which is waste according to chapter 3.4.4.

A 5S system will through standardisation also enable the manufacturing function to further develop and improve their workplace, where issues will be visualised and new possibilities of improvements can be found. However, it needs to be stressed that to

succeed in the long run, the employees need to feel a sense of responsibility, according to Liker chapter 3.5.5.

#### 5.1.1.5 Setups

Setup times are considered as waste since it is a non-value-adding activity, chapter 3.5.2, hence the interest of reducing it. The different setup procedures have been explained in chapter 4.2.1.5. The setups themselves are not that complicated at Company A, it is a straightforward procedure and times are within an acceptable range. However, according to the setup time definition, chapter 3.5.2, the time for a setup does not only include the setup but also preparation, adjustment and trial runs. It is within these elements that issues and opportunities of improvements can be found.

As discussed in chapter 4.2.1.5, the supervisors have the knowledge of the concept of handling internal setup as external setup. However it is in the preparation phase that planning is deficient. Since the supervisors have other activities to perform, preparation of setups are at times forgotten, and will be started too late. This will result in unnecessary machine downtime which is considered as waste in the form of waiting, according to Liker chapter 3.4.4. The root cause of the deficient planning is insufficient communication between the operator and the supervisor. In order to improve this element of a setup, standardisation on how a setup is carried out and communicated needs to be in place, which will enable continuous improvements as described in chapter 3.4.2.2.

As mentioned, Company A has the knowledge of the concept of converting internal to external setup times, which is considered to represent the first three levels of the SMED technique described in chapter 3.5.2, but fall short due to deficient planning. There will always be elements to continuously improve. However, the authors believe that there is more potential of improvement in level four. In order to further reduce setup times one needs to address level four in the SMED technique on how to successfully reduce setup times. The elimination of adjustments and trail runs is necessary in order to further reduce setup times and therefore increase flexibility and quality, and reduce inventory, chapter 3.5.2. The two most interesting setups can be identified at the folding and rolling processes. They both struggle with adjustments and trails runs, see chapter 4.2.1.5.

The issues at the folding process is a result of insufficient standardisation of folding instructions, which is a result of not accumulating the information on what has been adjusted from hand drawings so that it can be reused in the future. Also, increased visual control through standard work instructions should be considered since it would enable all employees to process more complex fittings at the folding machines in the long-run, fittings that are currently processed by the supervisors.

The issues of adjustments and trail runs at the form rolling machine have its root cause in its ageing technology, explained in more detail in chapter 4.2.1.5. However, this does not necessarily mean that an investment in a new machine is the right decision in order to reduce setup times. It should however be thoroughly investigated in accordance with the Lean philosophy, chapter 3.4.2.2. Savings could be made through reduced setup time as well as reduced scrap rates.

### 5.1.1.6 Capacity

Currently, capacity is only considered to be insufficient at the folding process. This, since all jobs go through this process and that one part has to be processed at a time, explained in chapter 4.2.1.7. The folding function is considered to be the bottleneck in the system mainly due to the state of the system at any given time where WIP buffers are high at this process, observed in Appendix H and I. A fitting has its highest amounts of parts and moments to be processed at the folding process. Therefore the need for good visual control through standardisation of work instructions is most urgent at this function in order to: minimise defects and mistakes, increase productivity and induce better control over the process as explained in chapter 3.4.2.2. This corresponds to the needs identified for setup reduction, chapter 5.1.1.5, hence improving the way setups are handled will also increase the throughput.

In contrast to the folding process, the punching process has excess capacity which is considered waste according to Liker, chapter 3.4.4, in the form of waiting (time on hand) has been identified and is described in chapter 4.2.1.7. The time on hand the operator has for every metal sheet processed by the machine is hard to control since it varies. However, this time could be utilised to prepare for setups.

## 5.1.2 *The Assembly Function*

### 5.1.2.1 Assembly Lines

There is a higher degree of control and standardisation in the assembly line compared to the manufacturing function. The fact that data on assembly times are collected and analysed and that master planning is based on capacity of the assembly function, see chapter 4.2.2.2, supports the argument. Also, the development of flow lines with visual control on standardised work instructions and a set standard of components at the lines indicate a higher degree of control and a continuous improvement initiative. These developments are in line with the Lean philosophy, described in chapter 3.4.2.2. However, there is a lack of controlling the way some set standards are followed. An example of this is described in chapter 4.2.2.1, were the standard group of fittings that are deemed suitable to be assembled on the flow lines are mixed with nonstandard, resulting in the flow lines not being utilised in an effective manner.

Operators at the assembly lines rotate and change stations every two hours inducing a greater knowledge and skillset amongst the operators, further explained in chapter 4.2.2.1. The knowledge and skillset is developed through operators teaching each other on the line when issues arise. This situation corresponds well with the Lean theory in chapter 3.4.2.3, which suggest that an excellent balance needs to be established between individual and group work in order to utilise both individual excellence and team effectiveness.

The insufficient organisation of tools mentioned in chapter 4.2.2.1, can at times cause delays in setups as well as other surrounding activities since employees have to go and search for a missing tool when he or she realise that it is missing. A worst case scenario could mean downtime at an assembly line due to the realisation of insufficient amount of tools which would negatively affect the productivity. However, this is not a big problem at the assembly function but the implementation of a 5S

system, described in chapter 3.5.5, could still be justified as a safety precaution. The implementation of a 5S system would expose unusual conditions and if a tool was missing this would be noticed before it is actually needed.

#### 5.1.2.2 Material Supply

A work structure and system of how material supply should be carried out has been developed not too long ago at Company A. The description in chapter 4.2.2.3 covers the structure of this system which includes pickers, kitting, supporting wire function, a forward picking area and a warehouse management system in place. These are all building blocks that can set the foundation for a fully implemented well-functioning material supply system. However, currently resources are scarce which has slowed down the continuous improvement of the material supply system. This situation is caused by what the authors consider to be a catch 22, where resources are consumed by wastes such as waiting and unnecessary movement, explained in chapter 3.4.4, and therefore causing a situation where resources are scarce thus hindering the continuous improvement of the material supply system. There are three areas identified that could help the future development of the material supply system, these are covered below.

A solution to the suggested issue of holding semi-finished goods inventory, covered in chapter 5.1.1.2, will not only reduce setup times in manufacturing, it will also enable picking from this inventory to be carried out more efficiently. This because, with more structure and an expressed strategy of what parts to store, the picker will know what is stored and can efficiently pick items, hence reducing the waste of unnecessary movement and therefore reducing setup times in the assembly function.

To further reduce setup times in the assembly, Company A needs to continue to standardise dedicated component storage locations. The current degree is described in chapter 4.2.2.3, and is deemed to be insufficient and the root cause to solve in order to reduce kitting cycle times. Currently the situation causes the earlier mentioned wastes.

As described in chapter 4.2.1.3, the information flow ends when the processing of WIP is completed in the metal shop. This results in that all WIP that comes of the paint line has no information on product or job attached to it. Since fittings can look very similar it is very hard for the picker to locate the correct load carrier of WIP that is requested on the pick list, further inducing the earlier mentioned wastes.

Successful implementation of any or all of the above stated situations will increase flexibility and reduce lead times, as suggested by the theory in chapter 3.5.2. Also, due to better structure, kitting cycle times can be reduced as well as the amount of invalid kitting which will reduce the frequency of standstill on the assembly lines. This will also free up time for supervisors to focus on improvements rather than fire fighting.

## 5.2 Product Development

### 5.2.1 Stage Gate Model

The structure of Company A's project system closely resembles that of a typical Stage-Gate model. The CPS stages are sequenced very similar to that described in the theory in chapter 3.3.1. Senior managers also have the authority to open the gates, and a thorough product evaluation is performed at the projects conclusion, all in accordance to the theory. The CPS allows a clear structure to be set for the designers where creativity can be focused on at a specific time frame and focus on implementation can be done in another. In this sense the Stage-Gate model fits and supports the company very well.

The main difference is however noted when it comes to how the model is utilised in the development department. While the theory in chapter 3.3.1 states that a Stage-Gate model leads to an extremely structured model, Company A implements it in a more flexible manner depending on the scale of the project and in some cases it is disregarded completely, as described in chapter 4.3.1. These disregarded cases are usually associated with small-scale modifications that could be 100 in a month. This clearly shows that the model is not yet optimised for the company's various project sizes and that improvements can be made. This could involve either using a complementing tool, in the form of a project system better suited for product modifications, or to revise the CPS to match the modifications more appropriately. This would increase the streamlining of all project sizes and increase the flexibility of the department.

### 5.2.2 Design for Manufacturing and Assembly

Designing their products for manufacturing and assembly is a strategy that Company A always tries to keep under consideration. It is addressed early in the design process where the layout and form design for the product is realised, as is stated in chapter 4.3.2. This follows the theory in chapter 3.3.2; that by addressing these early in the development process it can help improve the quality of the assembly process since it is dependent on having a good product design. In addition, the close interaction between the development and production departments helps support the use of concurrent engineering together with DFMA techniques. This is seen in both manufacturing by assessing various tooling processes to be preferred and in the assembly where both the engineering and production manager help plan the process, as described in chapter 4.3.2.

There are however, as stated in chapter 4.3.2, room for improvement in using the DFMA strategy. This is made apparent both through interviews and observations made by the authors. Several cases brought up in chapter 4.3.2 show that the company's assembly process is not aligned with the theoretical principles explained in chapter 3.3.2. The DFMA-principle of reducing the number of standalone parts in a product, mainly consumables, has not been thoroughly examined by the product development department, generally because of the lack of resources. It is stated in the theory, chapter 3.3.2, that reducing standalone parts can make significant improvements to the assembly process and the necessity of parts can be efficiently



assessed through the use of the three criteria used in the Boothroyd-Dewhurst DFA methodology. Improving the product design through the reduction of consumables also follow the Lean concept by reducing waste, as described in chapter 3.4.4, by eliminating the risk of over processing or incorrect processing through a better product design, excess inventory, and defects. Because of these potential opportunities of improvement associated with utilising DFMA, the company should reconsider putting aside more resources to analyse this. Redesigning a product or product family should be done with the support of the DFMA methodology in order to examine its potential.

### *5.2.3 Standardisation*

The use of standardisation at Company A is apparent but is evaluated and documented on a more holistic level of the design for most products. Standardisation is largely assisted by the Stage-Gate system where the gates force the designers to evaluate the design on several aspects throughout the development. Standardisation is utilised in accordance to the chapter 3.3.4, to support the development process, which is also stated as the reason of its implementation at Company A described in chapter 4.3.3. Also, Company A explains that by standardising certain components, delivery times can be upheld as dependency is not placed on one sole supplier but on multiple, and thus establishing a more flexible supply. The company's use of CAD is an effective way to store and access drawings and models and to accordingly streamline the work process.

Opportunities of improvement are seen on the smaller levels of the product design since the Stage-Gate system's focus lies on the product as a whole. Because of this gap in the Stage-Gate model, preferable standardisation requirements are memorised by the designers and managers. This results in an inefficient procedure to transfer this vital information to employees who are unfamiliar with the established standards.

These gaps need to be addressed, as the solution of memorising requirements is not optimal. Along with the growth of the company and their product mix a necessity to organise this information will become vital for maintaining a consistent quality in product standardisation. The lack of an effective system to relate information concerning standardisations will hinder continuous improvement as explained in chapter 3.4.2.2, where standardisation must firstly be established before improvements can commence. A more thorough checklist to help with standardisation on the component level should be established to compensate for the gaps in the Stage-Gate. Also, a systematic way in which relevant information can be communicated should be established, or the current one should be improved, in order to relieve the designer from memorising certain aspects of their work. This would help streamline the work process for the designers.

### *5.2.4 Modularity*

Company A's customer oriented product strategy, that has resulted in the company having to keep a large product assortment, is achievable largely because of their modular product design. As stated in chapter 3.3.3, one of the drivers in using modularity is to increase or maintain the efficiency of the production and product

development while increasing the company's product variety. It is thus largely because of their modular designs that the production and development departments are not overwhelmed by their wide product range, which is explained in chapter 4.3.4. Their use of differentiation to increase product variety, and their use of commonality to decrease costs and workload is utilised in the company's product strategy. This is in accordance with the theory stated in chapter 3.3.3.1 and 3.3.3.2 respectively. A modular product design can also be linked to the Lean concept and the philosophy that states that decisions should be made on a long-term basis rather than short-term, as explained in chapter 3.4.2.1. A modular design could be more consuming in the design phases (short-term) but will help the designer when it comes to future modifications such as upgrades and adaptations. This has been observed to some extent in Company A's LED conversion project.

The company does not, however, have a set strategy as how to apply a modular design on products, which could be problematic in the future as the company's product mix expands. Explained in the chapter 3.3.3; more emphasis is needed in the conceptual and embodiment phase of development, and having no real structure in applying a modular design could lead to an unmanageable workload for the designers. The company exhibits a good product design when it comes to variety, offering many variations within a product family. The use of commonality is on the other hand not applied in the same degree as differentiation in their products. A lot of different components have been observed and it becomes more apparent in the assembly process where most of these come to use. Many of these parts are hidden for the end customer and as such would not jeopardise the distinctiveness of the fitting if subjected to an increase in commonality. Applying commonality can, as stated in chapter 3.3.3.1, reduce stock and workload for the involved but it should only be done if the integrity of the fitting is not at risk. This could be an area where improvements can be made. It would also be in line with the aim of reducing waste in the form of over processing or incorrect processing, unused employee creativity, excess inventory, and defects, stated in chapter 3.4.4. By decreasing the amount of different components needed a reduction of excess inventory would be achieved. A decreased risk of producing defects would also be achieved as a reduction of different components would enable the employees to gain a greater understanding of the components used and would help standardise the work process. The product development department will have a lot to gain from increasing the level of commonality since tedious work procedures involving component updates would be reduced by utilising less unique components in their products. This will allow them to instead focus on value adding activities. An analysis should be conducted on some products in their degree of commonality and what benefits an increase in commonality will have on the company.

### *5.2.5 Evaluation*

Most of the current product evaluation procedures are conducted in the end or near the end phase of the development process. Although the gates offer some evaluation opportunities throughout the products development process, these evaluations may not address all the areas that would make the product better suited for DFMA, modularity, or standardisation. As explained in the theory for both DFMA and

modularity, chapter 3.5.7 and 3.3.3, in order for these strategies to be properly utilised in the product they need to be instigated in the early design and conceptual phases of the process. An evaluation tool that addresses these strategies would accordingly be useful, also expressed by the engineering manager in chapter 4.3.5. A lot of the tasks assigned to the product development department involve cost estimations, which in order to be done consistently requires accurate assembly data. This data will require to be updated in order for it to be in line with the cost implications of the product modifications demanded by the customer. Because of this, an evaluation tool is needed that can account for these modifications quickly and with ease. The tools first intent would be to assist the designers with the cost estimations and could be expanded to the product development process as well. This would increase the flexibility and efficiency of the product development department. The use of evaluation tools will also enable the department to reflect more on its work, analyse different design alternatives, and through this become a better learning organisation, explained in chapter 3.4.2.4.

### **5.3 Product Realisation Process**

In the product realisation process (PRP) aspects of engineering, design and production are deemed crucial to control in order to fulfil the objective of producing the product features required by the customer. Company A is successfully producing products which mean that they manage the PRP to a certain degree.

According to the ISO 9001 standards, an organisation needs to control the design and engineering process of a product. In section 3.1, Hoyle states ten primary steps to control in order to assure that the design and engineering of a product is on course towards its objective. The authors suggest that Company A considers these ten steps by utilising a variant of the Stage-Gate model, the CPS explained in chapter 4.3.1, in order to plan the processes needed to fulfil the features of the product required by the customer, which is in line with the PRP described in chapter 3.1.

However, as a result of the strategy ETO, Company A disregard the CPS since it is not developed to fit smaller projects or re-engineering of products, further described in chapter 5.2.1, and therefore lose control of the design and engineering process. This will reduce the production system's efficiency and flexibility since all aspects of the production planning phase are not considered.

Production is carried out in a controlled manner, however in varying degrees. The assembly function has reached a higher state of control and fulfils the conditions, according to Hoyle chapter 3.1; however some aspects are more controlled than others. The manufacturing unit is in comparison far less controlled and does not fulfil all the standards.

The tracking and identification of WIP is insufficient, which is a crucial condition to control in an environment of ETO and MTO. The designs between different products can at times be very similar which further argues that tracking and identification of WIP is crucial to control and an area in need of improvement.

Furthermore, a high product range will introduce a high degree of tools, jigs, and equipment. This situation has caused a lack of organisation of these within the manufacturing site, further explained in chapter 4.2.1.4, a state that does not correspond to a controlled condition.

The company's current degree of utilising the design techniques of commonality and DFMA can definitely be higher in order to increase the efficiency and flexibility of the PRP. These techniques are currently utilised in a casual manner based on logic rather than the proven theories. However, still to a high enough degree to have control over the design and engineering process.

The summary of the identified gaps in section 6 will if improved; both increase the control of the PRP and the standards fulfilled as well as increase the efficiency and flexibility of already controlled areas.





## 6 Summary and Selection of the Identified Gaps for Further Work

*The identified gaps have been summarised in this chapter. Presented to the reader are also the chosen gaps for an in-depth study and why these have been chosen.*

The tables below will summarise the identified gaps and what area that is subject to the change. Also, a brief proposal on what to improve is described and what expected improvements these changes can bring to Company A.

<b>Affected area</b>	<b>Gaps</b>	<b>Proposal</b>	<b>Expected Improvement</b>
MFG	Capacity planning.	Data collection on process times for all manufactured parts.	Enables capacity planning and lowered levels of WIP. Increased flow and lead time. Establish capacity control of the PRP in the manufacturing unit.
MFG	Change the culture of overproduction.	Senior management needs to set standards to never overproduce unless it is approved and follow up to ensure that the standard is followed.	Decreased WIP inventory levels. Visualisation of quality problems. Countermeasures for quality problems can be identified.
MFG	An un-systematic and inefficient SFGI.	Standards on how to manage the inventory, what parts and quantities to be held needs to be established. The SFGI should be designed & engineered in order to satisfy the customer demand in an efficient manner.	Reduced number of setups, decreased lead-times, and increased picking efficiency.
MFG	An insufficient flow of information for WIP.	Implement a visual control system. This will require engineering of a proper interaction of the information and material flow as well as design and engineer new load carriers.	Increased productivity, reduction of defects and mistakes, simplified communication, and control of the environment.

<b>Affected area</b>	<b>Gaps</b>	<b>Proposal</b>	<b>Expected Improvement</b>
MFG	Inspection of incoming goods.	Development of standardised procedures to be carried out for incoming goods with focus on raw material. Design and engineer a supplier performance tool.	Reduction of quality issues, unnecessary transport and movement. Increased responsiveness to quality issues. Increased efficiency. Increase the level of inspection within the PRP. Enable supplier control through measuring KPIs.
MFG	Department lack orderliness, structure and standard work procedures.	Development and implementation of a 5S system.	Improved efficiency, moral, safety, control and quality. Creating a culture of continuous improvement.
		Standard work procedures on how a setup is communicated and carried out needs to be established.	
MFG	Reduction of setup times.	Standardise folding instructions via feedback loop and communicate through visual control. This in order to design and engineer the folding process to better fit the manufacturing process.	Increased flexibility. Reduced scrap rates. Increased machine utilisation.
		Thorough analysis if an investment in a new form rolling machine is economically justified. This investment proposal should be carried out by the engineering department.	



<b>Affected area</b>	<b>Gaps</b>	<b>Proposal</b>	<b>Expected Improvement</b>
MFG	Folding function identified as bottleneck.	Standardise folding instructions via feedback loop and communicate through visual control. This in order to design and engineer the folding process to better fit the manufacturing process.	Minimised occurrence of defects and mistakes, increased throughput, and better control of the process.
ASSY	Insufficient organisation of tools.	Develop and implement a 5S system in order to set standards and sustain structure in the long-run.	Increased productivity and control.
ASSY	Inefficient material supply.	Set dedicated storage locations for all components and consumables.  Structuring the way semi-finished goods are stored.	Reduced setup times. Reduction of invalid kitting. Reduced kitting cycle times and increased picking efficiency. Disembarrass time for supervisors. Increased flexibility.
PD	CPS is not optimised for various project sizes.	Revise the stages of the CPS to match the project sizes more appropriately.  Introducing a complementing tool for product modifications.	Increased flexibility. Improved streamlining of projects.
PD/ ASSY/ MFG	Product designs are not fully optimised for manufacturing and assembly.	Assess the products current manufacturability and assemblability utilising the DFMA methodology.	Increased efficiency, reduction of defects, and inventory reduction in assembly.

<b>Affected area</b>	<b>Gaps</b>	<b>Proposal</b>	<b>Expected Improvement</b>
PD	Inefficient information structure for standardised components.	<p>Develop checklists to ensure that all standardised components have been considered.</p> <p>Establish a systematic way on how information of standardised components is communicated.</p>	Streamlining of the work process.
PD/ ASSY	The level of commonality on product family design is not optimal.	Conduct an analysis on the benefits of increased commonality and assess the current level of commonality of the products.	<p>Cost reduction.</p> <p>Decrease defects and increased efficiency in assembly. Increased efficiency in product development.</p> <p>Lowered component inventory levels.</p>
PD	Inefficient handling of cost estimations for customised orders.	Development of a system to estimate costs that correspond to assembly times.	Increased efficiency and flexibility.

## Chosen gaps

For the future state analysis the authors have chosen to proceed with the gaps that have the highest potential impact on improving the efficiency and flexibility. However, some consideration has to be taken into account due to feasibility reasons. Due to the scope of the project, the authors will discuss some of the gaps that have not been chosen in chapter 8.2.

The authors presented the 15 identified gaps to the Operations Director at Company A. Discussions about potential and feasibility led to a mutual decision for an in-depth study of the gaps presented below. When considering the potential both the success rate and potential impact on efficiency and flexibility was discussed. Constraints in feasibility considered both the 20 week constraint of the thesis as well as the reality that certain gaps needs to be improved/implemented as a prerequisite before the next gap can be improved/implemented.

In an attempt to quantify the potential of improving the chosen gaps, a simple ranking system has been utilised. The purposes of increasing the efficiency and flexibility have been individually ranked in a span of 1-5. The potential value is simply calculated by adding the two. This is visualised in table 6.1. The authors have not considered additional benefits that could come from improving these gaps.

**Table 6.1** This table visualise the potential impact on efficiency and flexibility for the chosen gaps

Chosen gaps	Efficiency	Flexibility	Potential value
An un-systematic and inefficient SFGI.	4	4	8
An insufficient flow of information for WIP.	4,5	4,5	9
Inspection of incoming goods, focus on raw material.	2	3	5
Department lack orderliness, structure and standard work procedures.	3	3	6
Inefficient material supply.	4	4	8
Product designs are not fully optimised for manufacturing and assembly.	4	3	7
The level of commonality on product family design is not optimal.	4	4	8

The chosen gaps:

- An un-systematic and inefficient SFGI.
- An insufficient flow of information for WIP.
- Inspection of incoming goods, focus on raw material.
- Department lack orderliness, structure and standard work procedures.
- Inefficient material supply.
- Product designs are not fully optimised for manufacturing and assembly.
- The level of commonality on product family design is not optimal.

From the current state analysis the authors considered the manufacturing function to be underdeveloped in comparison to the assembly function. The first five chosen gaps will all focus on changes in the manufacturing function with the main focus of bringing it to the same standard as the assembly function in order to create an improved overall flow within the production system.

The last two gaps were chosen in order to correspond with the purpose of the project. The two gaps focus on the design of the products where improvements will focus on supporting the assembly function and product development department.

The following chapters will refer to the chosen gaps, providing in-depth proposals and how these may be implemented in order to increase the efficiency and flexibility of the product realisation process.





## 7 Future State Analysis

*The reader will be provided with an in-depth study of the gaps chosen. Detailed proposals on how these gaps can be improved and suggestions on how the company could implement the solutions are provided.*

### 7.1 Inspection of Incoming Goods, Focusing on Raw Material

In order to assure that Company A can eliminate the issues that arise from insufficient inspection of incoming raw material which in Company As case are metal sheets, discussed in chapter 5.1.1.1, an ILMS was developed. The system is built upon a set of standard procedures on how to manage incoming raw material and support evaluation of supplier performance. Since there is no such system currently in place, the proposed solution will only cover the incoming raw material. However, it can and should be further developed to cover all incoming goods in the future.

Standard work procedures have been developed on how to handle an inbound delivery which will enable employee flexibility since work procedures are documented rather than memorised. The standards should be visually communicated in the area of incoming raw material by using the designed information sheet visualised in figure 7.1.



**Figure 7.1** The established standard work procedures for incoming raw material

The standards have been developed in order to remove variations from the process and yet be generic enough to provide some flexibility, an approach that follows Likers take on standardisation, described in chapter 3.5.5. The three standard work procedures are all conducted to some extent in the current state. However, not in a systematic way, rather as a work habit when needed or when issues arise. Establishing the standards and a systematic way on how and when to conduct them will enable Company A to eliminate the wastes mentioned in chapter 5.1.1.1. This will result in a system that will not induce further workload, rather streamlining the work carried out and making it more efficient.

Detailed documentation on how to carry out the second standard in figure 7.1 have been developed. The documentation on inspection is visualised in Appendix B and covers two main aspects; quality and delivery conformance. The detailed standard work procedures can be viewed in the inspection documentation, below a general description and reasoning on established standards will be provided.

Quality conformance is assured by manually inspecting the metal sheets. There are two common types of issues that the inspector should identify to assure that the material is free of defects; obvious damages from hard impacts on the metal sheets and wavy metal sheets due to faulty manufacturing by the supplier. If any of the two issues have been identified it should be reported by filling out an electronic delivery discrepancy form, visualised in Appendix A.

Delivery conformance is assured by manually measuring and inspecting three aspects; dimension conformance, quantity conformance and material conformance.

1. **Dimension conformance** – Raw material should be rejected if a sheet's thickness deviates from the specified by more than 0.1 mm. This since a larger tolerance will heavily affect the outcome of the manufacturing processes and would also be considered to be another type of metal sheet, hence a non-conforming delivery.
2. **Quantity conformance** – By measuring the thickness of one sheet and multiplying it with the stated delivered quantities, the employee can compare this result with the measured height of the stack of sheets. For example, quantities of sheets multiplied with the measured thickness should equal the measured height. The objective of the measure is to identify greater discrepancies since it is a very time consuming and complicated task to manually count all the metal sheets. Thus, only discrepancies greater than 20mm should be reported. The high tolerance will guard against discrepancies being reported due to the fact of small variances in thickness of the sheets on one pallet.
3. **Material conformance** – Visual inspection of the material will be sufficient to determine if the correct material type have been delivered.



These three aspects should be checked against a delivery docket that the supplier provides upon delivery. If any discrepancies have been identified the employee should fill out the delivery discrepancy form.

When a discrepancy has been identified, the filled out discrepancy form should be e-mailed to the purchasing officer. To streamline the process, a small work station consisting of needed utilities and a computer where work documents can be accessed should be setup in the raw material inventory. The purchasing officer will then follow the checklist, visualised in Appendix A, provided in the discrepancy form to ensure that a claim is conducted and the process completed. These standard procedures will enable communication of the needed information between the inspector of the goods, the purchasing officer, and the supplier in a closed streamlined loop, ensuring quality and delivery conformance. The set tolerances on dimensions and quantity conformance should be regarded as a starting point, and tolerances can be further reduced when data has been gathered and follow up conducted.

Company A should not only inspect incoming raw material to guard against defect material finding its way into the manufacturing process, they also need to evaluate their suppliers and follow up on the measured results in order to develop a world-class supplier base. This means that the delivery discrepancy forms will not only act as a supporting document in order to handle claims, they will also act as data collection sheets.

The ILMS is developed to evaluate the suppliers of raw material on three KPIs;

1. **Ratio of rejected orders (order reliability)** – Definition: if any of the incoming goods are defect or non-conforming, the whole order is subject to a reject.

$$\text{Calculation: } \% \text{ Rejected orders} = \frac{\text{rejected orders}}{\text{total orders}} * 100$$

2. **Ratio of rejected order lines (order line reliability)** – Definition: If any of the goods are defect or do not conform to the order, the order line is subject to a reject.

$$\text{Calculation: } \% \text{ Rejected order lines} = \frac{\text{rejected order lines}}{\text{total order lines}} * 100$$

3. **Ratio of rejected goods (goods reliability)** – Definition: goods that are defect are considered as rejected goods.

$$\text{Calculations: } \% \text{ Rejected Goods} = \frac{\text{rejected goods ordered}}{\text{total goods ordered}} * 100$$

The definitions are obviously developed for the purpose of measuring the KPIs and Company A should not reject a whole delivery if any of the incoming goods are defect in reality. The delivery discrepancy forms will provide collected data for all three KPIs and data on total orders, total order lines and total goods ordered will be provided by the MRP system. Additional data that should be collected is the amount of claims and credits notes, this to further provide a good base to evaluate supplier performance.

Data should be input to the supplier performance evaluation tool on a monthly basis by the purchasing officer (PO). Calculations of KPIs will be done automatically and presented in tables. The evaluation tool is visualised in Appendix C. Since no data has been collected, the values presented are merely to visualise the functionality of the tool. It is proposed to rate the suppliers on quality and delivery conformance based on the KPIs of goods and order line reliability. Order reliability should act as a support measure in order to visualise an overall performance.

1. Goods reliability – Quality conformance
2. Order line reliability – Delivery conformance

In order to follow up on KPI results, performance goals must be defined. The authors propose that Company A conduct a review of available data on claims and credits to establish a history for each supplier. This should be followed by a meeting with each supplier where Company A explains that they will start to evaluate supplier performance and state what KPIs will be utilised and how they will be measured. Together with the supplier, performance goals can be set and are clearly understood by both parties. Further development of performance goals could be to establish a bonus and penalty fee structure that relates to the performance of the supplier.

Company A currently have two suppliers of metal sheets. The PO should review and follow up the results on a quarterly basis. When the review is conducted the suppliers involved should be updated on their performance, and issues or achievements should be discussed. This will enable Company A to continuously collaborate and improve with their suppliers and establish a world-class supplier base.

When implemented, the ILMS will immediately reap the benefit of eliminating defect raw material finding its way into the manufacturing process, hence reducing the wastes of unnecessary transport, unnecessary movement and defects. Reducing the mentioned waste will increase efficiency within the manufacturing function. Also, it will set a starting point for Company A to evaluate and follow up on supplier performance, which is necessary in order for Company A to continuously improve together with their suppliers. Since no measurements are conducted at the moment it is hard to quantify the gains in terms of savings and increased efficiency. However, as stated earlier, since the ILMS is a structured way of conducting what is mostly already carried out in an unsystematically manner, the investment is minimal. Therefore, Company A should start to implement and utilise the system as soon as possible. Implementation of the system is fairly straightforward and can be setup after involved employees have been educated on the standards procedures and how to manage the evaluation tool and when supplier performance goals have been established.

## **7.2 An Un-systematic and Inefficient SFGI**

Ideally in a MTO environment products should only be produced when there is an order. However, in reality most systems have a mix of CODP as described in chapter 3.2.2. This is also the case for the production system at Company A. In chapter 4.2.1.2 and chapter 5.1.1.2, the un-systematic way of overproducing and holding this

inventory has been explained. This situation has led the authors to develop a systematic way of managing overproduction.

First of all, a set standard on what fittings that should be held in the SFGI needs to be established. Since demand for specific products has high monthly variations, data was analysed for all the produced fittings over a twelve month period between January 2012 and February 2013. In addition to this, all customised fittings that had been produced over this period had to be disregarded since there is no logic in holding this type of inventory. This left the authors with approximately 40% of standard fittings, visualised in table 7.2.

With the objectives to reduce number of setups, decrease lead-times and increase picking efficiency while still maintaining a high turnover, the fittings that had been ordered and produced most frequently and in greatest total quantities was chosen as candidates to become standard fittings in the SFGI. Visualised in table 7.1 are the candidate fittings and in table 7.2 their share of the total produced fittings. These candidates account for 17 percent of the total amount produced and 43 percent of standard fittings produced.

**Table 7.1** Overview of orders and quantities produced for the candidate fittings the last twelve months. Jan – 12 to Feb - 13

Fitting	Quantities produced	Customer Orders
<b>A</b>	6829	110
<b>B</b>	5430	48
<b>C</b>	1343	47
<b>D</b>	957	19
<b>E</b>	1137	31
<b>F</b>	926	46
<b>G</b>	933	59
<b>H</b>	815	47
<b>SUM</b>	<b>18370</b>	<b>407</b>

**Table 7.2** Total quantities produced the last twelve months

	Quantities	Percentage of total	Percentage of standard
Produced last twelve months	107000	100%	-
Standard produced last twelve months	43000	40%	100%
Identified candidates	18370	17%	43%

In order to determine if it is economically justified to hold these fittings in a SFGI, an analysis was made using the EOQ theory, described in chapter 3.5.3.

Critical parameters that needed to be determined for each fitting were the holding cost, and internal ordering cost which is the total setup costs for all processes when producing a specific fitting. The holding cost was determined by using Company A's internal annual interest rate (i) of 20 percent multiplied by the value of the goods (c). Due to lack of internal data on precise value for all of the fittings analysed, a general value was utilised in the calculations for all fittings. A chosen general value of \$30 was used and obtained from internal data for one of the fittings. This value is assumed to be representative for all the fittings since the manufacturing processes and materials used are similar and the value corresponds to the value of a fitting when it has been painted. In addition to this assumption, a sensitivity analysis have been conducted with lower and upper boundaries for the holding cost and how it affects the bottom line, this can be viewed in Appendix K.

The internal ordering cost was determined by generalising the obtained data from the author's value stream maps and is assumed to be representative for all the fittings since a setup is conducted in a similar manner for a specific process, detailed information on critical processes setups is described in chapter 4.2.1.5. The number of setups at each process was determined by observations, interviews and by analysing drawing documents. From this a total setup time could be calculated. The ordering cost was then determined by multiplying the total setup time with the company's standard cost of \$60 per working hour for running the manufacturing function. Specific data for holding cost and ordering cost can be found in Appendix J and L.

The calculated optimal order quantity ( $Q^*$ ) and the corresponding number of optimal internal orders are visualised in table 7.3, where it is compared to the current number of maximum and minimum internal orders. Complete calculations can be viewed in Appendix J.

**Definitions:**

- **Minimum internal orders** – If all of the customer orders for a specific fitting within a work week are batched as one job in manufacturing.
- **Maximum internal orders** – If no customer orders for a specific fitting within a work week are batched as one job in manufacturing.

**Table 7.3** One internal order relates to an ordering cost that is based on total number of setups within the manufacturing function for a specific fitting

Fitting	Minimum internal orders	Maximum internal orders	Opt Number of internal orders* = D/Q*	Q* = batch size
<b>A</b>	41	110	31	219
<b>B</b>	23	48	26	208
<b>C</b>	28	47	8	160
<b>D</b>	12	19	7	144
<b>E</b>	22	31	7	157
<b>F</b>	27	46	9	102
<b>G</b>	30	59	7	133
<b>H</b>	25	47	7	124
<b>SUM</b>	<b>208</b>	<b>407</b>	<b>102</b>	<b>1248</b>

The optimal batch size, Q\* in table 7.3, corresponds to the possible maximum quantities to be held in the SFGI. Visualised in table 7.3, is the minimum and maximum amount of internal orders which relates to a best case and worst case scenario in order to enable a benchmark costs against the optimal amount of internal orders.

With the calculated optimal amount of internal orders, optimal order quantities and determined ordering and holding costs, the authors could calculate the corresponding total yearly costs for each fitting; utilising two equations:

$$\text{Cost for SFGI, } C^* = \frac{Q^*}{2} h + \frac{D}{Q^*} A ;$$

$$\text{Cost for internal orders, } C = A * \text{Internal orders}_{\max, \min}$$

The cost calculations are visualised in table 7.4.

**Table 7.4** Cost calculations and comparison for the candidate fittings

Fitting	Cost (\$)	SFGI	Internal order costs best case (\$)	Internal order costs worst case (\$)	Minimum Savings (\$)	Maximum Savings (\$)
<b>A</b>	1312		861	2310	-451	998
<b>B</b>	1251		552	1152	-699	-99
<b>C</b>	958		1596	2679	638	1721
<b>D</b>	864		780	1235	-84	371
<b>E</b>	942		1430	2015	488	1073
<b>F</b>	615		918	1564	303	949
<b>G</b>	799		1710	3363	911	2564
<b>H</b>	747		1425	2679	678	1932
<b>SUM</b>	<b>7487</b>		<b>9272</b>	<b>16997</b>	<b>1785</b>	<b>9510</b>

If a SFGI would hold all the fittings in table 7.4, the saving would vary from \$1785 - \$9510 based on the data from the last 12 months. However, the SFGI is limited in space and has 32 pallet locations and 16 smaller compartments. A pallet can hold, depending on the fitting, approximately 25 fittings. This means that the SFGI can hold approximately 800 fittings, where supplementary parts can be held in the smaller compartments. The sum of the optimal batch sizes in table 7.3 is 1248, which is a greater quantity than the SFGI can hold. Hence, a decision on what candidates to hold in the SFGI has to be made.

However, whatever fittings that are chosen to be held in the SGFI will all fulfil the main objectives of reducing setups, decreasing lead-times and increasing picking efficiency to a minimal cost or a slight saving.

To ensure high turnover, a wide product range and consistency in dimension in the SFGI, it is proposed to hold fitting A, B, E, F and H. Fitting A and B have by far the highest demand and is an obvious choice. The remaining fittings have a similar demand and selection is based on consistency in dimension and to enable a wider product range in the SFGI. Described in chapter 4.3.4 is the high amount of varieties a fitting can take when assembled to finished goods. Table 7.5 visualise the proposed fittings and their corresponding inventory quantities and savings.

**Table 7.5** Proposed fittings to hold in SFGI with quantities and savings

Fitting	Q* = batch size	Minimum Savings	Maximum Savings
<b>A</b>	219	-451	998
<b>B</b>	208	-699	-99
<b>E</b>	157	488	1073
<b>F</b>	102	303	949
<b>H</b>	124	678	1932
<b>SUM</b>	<b>810</b>	<b>319</b>	<b>4853</b>

Having established the possibility to utilise a SFGI and its benefits, some adjustments needs to be made before implementation can begin. The MRP system currently used by Company A has to be further developed in order to support a SFGI. Since the MRP system already supports inventory control, a built in WMS described in chapter 4.2.2.3, only minor adjustments will be needed in order for it to support a SFGI. However, this is a task for external technical support for the MRP system.

A few standard work procedures need to be established in order to manage the SFGI.

- When quantities are withdrawn from the SFGI, employee must at all times update the consumption in the MRP system.
- No optimal re-order points will be utilised. However, when inventory cannot satisfy an order for a specific fitting, the quantity produced should be equal to the quantities needed in the SFGI plus the quantities for the order. For example, if the optimal order quantity is 200 fittings and the current inventory level is at 30, the needed quantity in the SFGI is 170 fittings. If 40 fittings have been ordered the SFGI cannot satisfy this demand, hence the produced quantity should be 210 fittings.
- The second trigger for a replenishment of the SFGI is when the inventory level is zero.

In order to support further structure of the SFGI, dedicated locations in the pallet racks should be utilised for the chosen fittings. The racks should be divided into sections and clearly labelled with a description on what fitting is held in respective section. In addition to this, each pallet should hold identification labels, further explained in chapter 7.3. These changes will enable efficient picking in the SFGI since structure is established and information is visually communicated. Also, since locations are dedicated efficiency will increase as the learning curve for pickers increase.

The SFGI should be implemented in phases due to two main reasons; there is already SFG held in inventory and implementation should follow the PDCA cycle, explained in chapter 3.5.1. Company A should choose one of the proposed candidate fittings as

a pilot, the authors proposed either fitting A or B since they both have a high turnover, hence a high potential for success. Space needs to be released to the extent that 200 fittings can be held. The outcome should be measured and adjustments made if needed. If successful, then implementation should proceed until all proposed fittings are held in the SFGI. Also, to support an ever changing market, the evaluation tool that has been developed and used by the authors in order to determine what fittings to hold in the SFGI, should be utilised by Company A to assure that the held inventory in the SFGI is in line with future market trends and demand.

Furthermore, a structured SFGI will not only reduce setups, decrease lead-times and increase picking efficiency, the production system will also reap the benefit of decreased scrap rates and setup time variations. The reduction of total number of setups will directly induce a reduction of trial runs, hence reducing scrap rates. Also, with fewer setups, abnormalities during a setup will occur less frequently which will improve the material flow. The production lead-times for fittings in the SFGI can be reduced by a week, since production is scheduled a week apart in manufacturing and assembly, further explained in chapter 4.2.

### **7.3 An Insufficient Flow of Information for WIP Causing an Inefficient Material Supply**

There is a strong need for a solution to enable identification of WIP in order to eliminate wastes such as unnecessary movement and waiting, hence increasing efficiency and flexibility. The main objective and bottom line of a visual control system at Company A is to support the pickers with visual information on the load carriers in order to increase picking efficiency, reduce the amount of wrongly kitted jobs and reduce the risk of standstill at the assembly lines. Furthermore, a visual control system would also induce improvements such as reduced defects and mistakes, increased control of the environment and simplified communication. Described in chapter 4.2.1.3 is the root cause to why no information on WIP is available in the paint shop for the pickers and therefore a visual control system needs to cover both the metal shop and paint shop to enable an effective information flow.

To create a well-functioning information flow all processes needs to be covered. If a system is implemented without thoroughly considering all aspects of the material flow, the information flow might not be interacting properly with the material flow and the end result would be incorrect or no information attached to WIP in the paint shop.

There are two different levels of information that Company A could track which corresponds to the material flow. The lowest and most detailed level is the individual part level. This level considers all parts produced to make a fitting. For example, a fitting could consist of parts such as end caps, body, frame strips, frames, lamp holder brackets, gear tray and so on, all which have its own item number in the MRP system. The next level consists of painted sub-parts of the fitting which will be mounted in the assembly such as a painted body, painted gear tray, and painted frame which themselves can consists of the earlier mentioned parts. When these sub-parts have been painted they will all have unique item numbers in the MRP system.



The decision to take is to either track individual parts or painted sub-parts of the fitting. In order to track individual parts, the system would have to support information change. This since, when individual parts are processed to become a single part, the item number and corresponding information will change in the MRP system, for example, when two parts are spot welded together. Since the main objective is to end up with correct information attached to the WIP in the paint shop, to support the pickers, development of a tracking system for all individual parts in the metal shop is deemed unnecessarily complex.

The information provided on a picking list is described in chapter 4.2.2.3. Since the picker will identify the required WIP from the information corresponding to a painted parts item number, the needed information attached to WIP is clearly the information on the pick list and therefore the proposed level to track. This means that when the process starts, the information attached to a load carrier will belong to the painted part, even though individual parts are located on the load carrier. The tracking system developed will be considered a “belong-to” system, where parts on a load carrier belong to a higher level painted sub-part.

The proposed level to track will also fit the current production orders generated, described in chapter 4.2.1.3. Since the MRP system is generating unique bar codes for all painted parts of a complete fitting, a visual control system that can utilise this information is deemed most suitable. Therefore, a tracking system consisting of label printers and bar code scanners has been developed.

The developed system will be explained by referring to the numbered areas in the simplified material and information flow chart visualised in figure 7.2 and has its roots in the Lean principle of visual control, described in chapter 3.4.2.2.

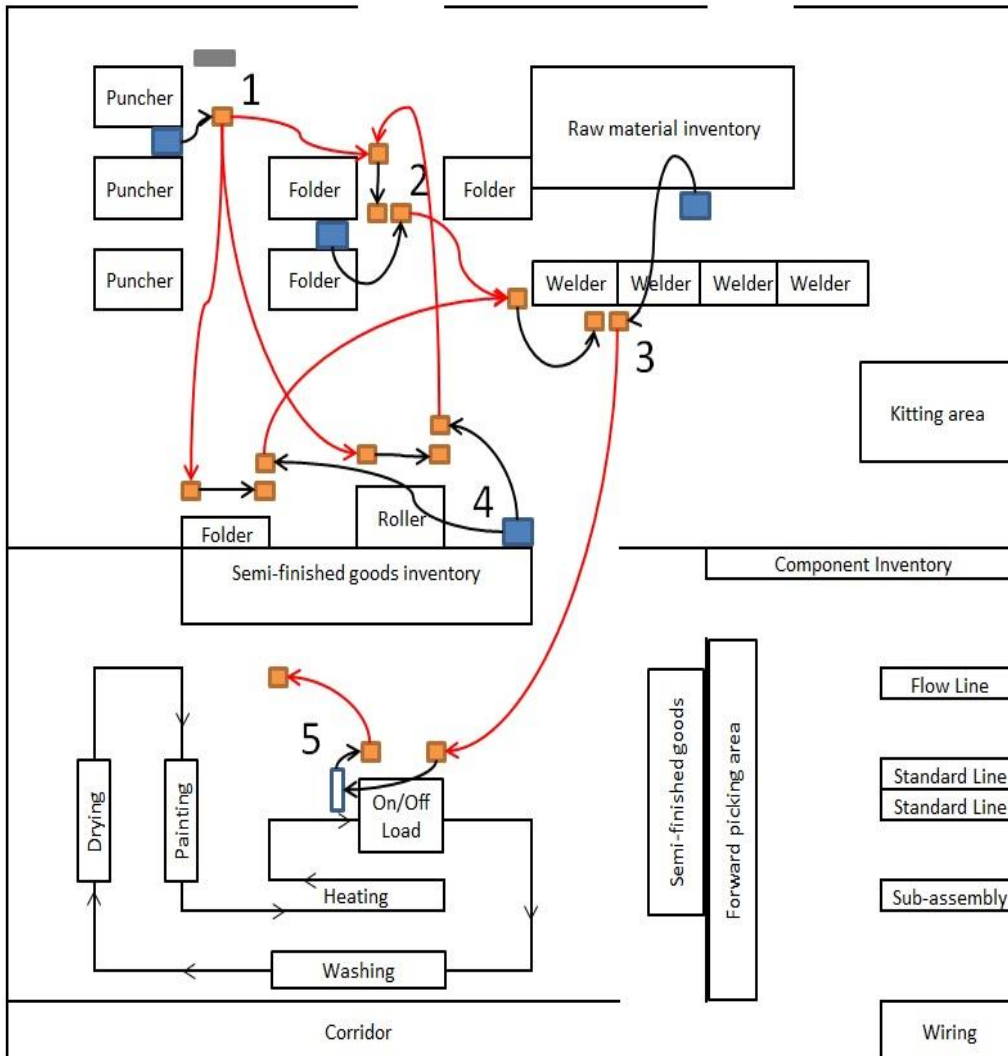
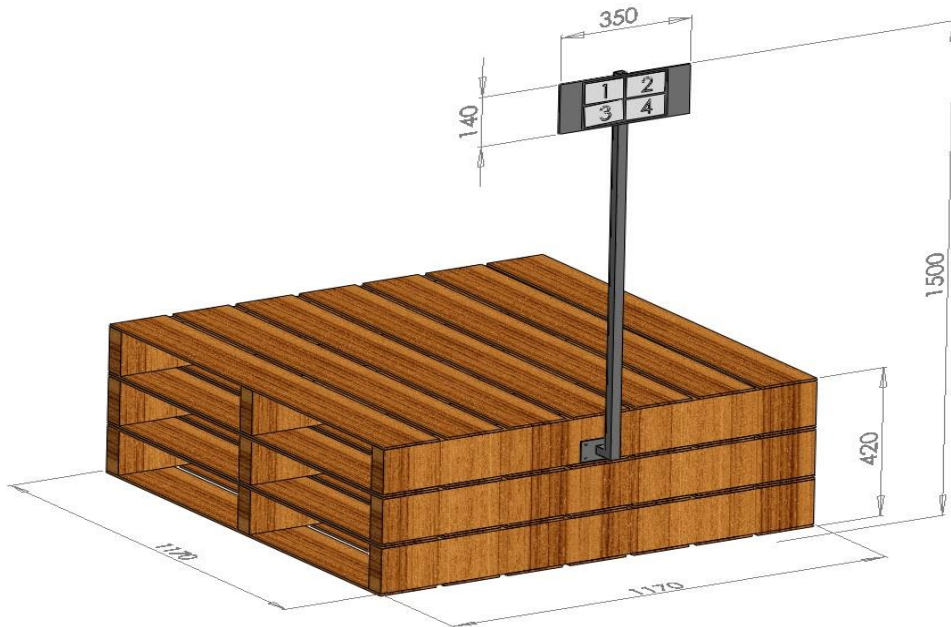

**Figure 7.2** Red arrows visualise the material flow with attached information and black arrows visualise the generated information flow. Brown squares are load carriers /pallets, the grey square is raw material and blue squares are label printing and scanning stations

The numbered areas, show in figure 7.2, are considered to be critical areas for the tracking system. The standard work procedure for an operator is that material to be processed is obtained from one load carrier, and the processed material is placed on another. This is visualised in figure 7.2 by the placed load carriers on the corners of the processes. Additional load carriers have been placed where there is a possibility that load carriers grown in volume due to the processing of parts.

The process will start in area one, at the punching function. At this step the operator will have to scan the bar code on the production order to produce the first label. Since a production order consists of multiple pages which relate to the painted parts of the

fitting, the operator will have to scan each bar code and place the label on the load carrier together with the matching part. The two designs of the label holder, which will be attached to the load carriers, is shown in figure 7.3 and 7.4.



**Figure 7.3** Concept design of the label holder attached to a three pallet configuration.

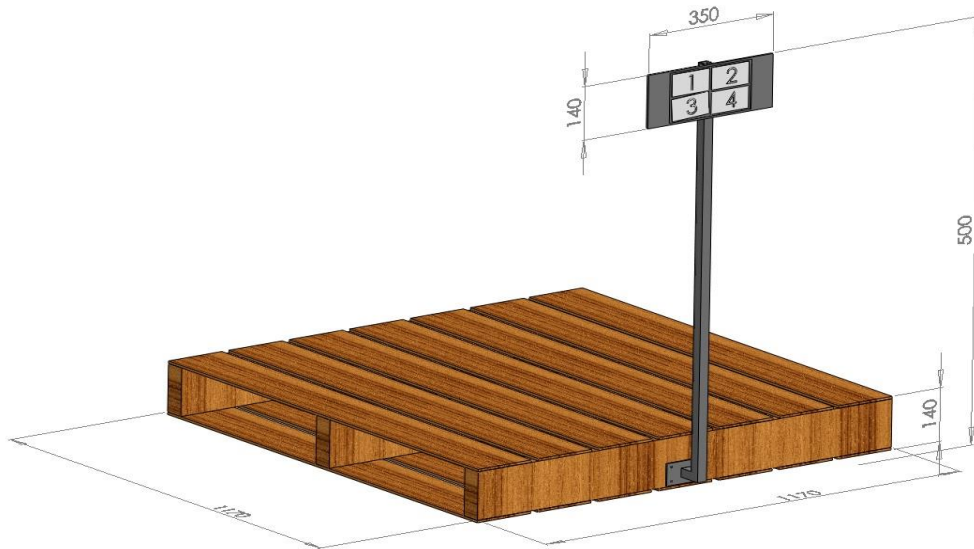

**Figure 7.4** Concept design of the label holder attached to a one pallet configuration.

The label holder is designed with plastic pockets where the labels can be placed. The dimension of the label surface is 350x140 mm and can hold four labels. With the set

dimension, the label holder can be configured to fit six labels if needed in the future. Also, in figure 7.3 the height from the bottom of the load carrier to the top of the label holder will act as an indicator for maximum stack height of WIP. The maximum stack height has been set to 1500 mm to ensure safety and reduce the risk of stacks collapsing. The design in figure 7.4 is only utilised as a load carrier for punched parts.

The surface of a load carrier can only hold a definite amount of parts, hence the reason to design the label holder to hold a maximum of four labels is considered sufficient. This since, one label relates to a painted part which itself consist of additional parts. Shown in figure 7.5 is a load carrier's surface utilised to its maximum. With the label system this situation would have corresponded to four labels. However, there might be the extreme case when four labels could be insufficient. This is however regarded as a rare occurrence and should be solved by loading another carrier.



**Figure 7.5** Figure visualise when a load carrier's surface is fully utilised

The design of the label itself is shown in figure 7.6. It will communicate information on item number, description of the item, date when label was printed and delivery date. The most critical information is the item number, since this is what the picker will try to locate visually. From tests, it has been established that the font size is big enough to be identified from a distance of 10-15 meters.



**Figure 7.6** Design of printed labels which will travel with WIP. Dimension of one label is 105x63 mm

When the process is completed at the punching function, the load carrier will travel to either area two, the folding function, or area four, the form rolling function. At this point the load carriers will consist of punched parts with the proper labels attached. Both areas have a printing station to enable the operators to duplicate the labels attached to the received load carrier. The reason for this is the needed flexibility to handle the volume change of the parts when they are processed. For example, a punched part is flat while after a form rolling process it will be curved, which will require a higher volume on a load carrier. Therefore, punched parts that required one load carrier could require several load carriers after either one of the processes depending on the quantities. When these situations occur, the operators will simply scan the bar code on the label and the printing station will be setup to automatically produce an identical label which should be placed on the additional load carrier.

When there is a 1:1 ratio of load carriers, the operator should move the label from the received load carrier and place it on the load carrier with the processed parts. Also, since the system is designed as a belong-to system, one or more parts will belong to the same label. If these parts are separated and placed on two or more load carriers, the operator will duplicate the correct label and place them on all the necessary load carriers. This to ensure that the information flow is never broken, and ultimately that the correct information will be attached to the load carriers at the end of the flow.

The printing station in area four will also act as a safety net since this is the last point of location in the metal shop before WIP travel to the paint shop. The printing station will supply parts that are sourced and painted but not processed within the metal shop, with its proper label and information before continuing its flow into the paint shop.

More or less all of the fittings produced will flow through the spot welding function, the exception being a couple of fittings which are solely folded. The previously discussed procedures should also be followed in area three. This is the last process before the fittings reach the paint line, visualised by figure 7.2.

When the material and information flow reach area five, the paint line, it has reached a critical point. This, since material and information will be separated due to the fact that the parts will be hung on the paint line and will not be located on a load carrier. The process takes approximately 90 minutes, which was observed during the VSM, Appendix H and I. A sub-system has been developed in order for the operators to be able to identify WIP that come off the paint line and its corresponding label of information. An alternative to the proposed system to come would be to simply keep the attached information on the load carrier and place the same items on it when the parts are taken off the paint line. However, this would cause congestion in area five due to a high amount of load carriers waiting for its corresponding parts to be processed. Also, a high amount of empty load carriers would induce confusion and an inefficient work pattern since it will be hard to determine what specific part and load carrier that belong to each other. The proposed sub-system will allow for load carrier flexibility and minimum congestion.

The sub-system will rely on visual communication and control which is in line with the system as a whole as well as the second pillar, process, of Likers 4P model, further explained in chapter 3.4.

The systematic way of separating information and material flow is built upon four components: a magnetic white board, indicators, numbering system and standard work procedures. The white board is setup to allocate labels to different numbers; shown in figure 7.7 is the concept design of the white board.

1	2	3	4	5	6	7	8	9	10
									10
									↑ 10
11	12	13	14	15	16	17	18	19	20

**Figure 7.7** The conceptual design of the white board for the sub-system

The first row of the white board is the standardised locations for the numbers; the second row will allocate the label/labels that are taken off the load carrier. The labels will be held in place by magnetic numbers corresponding to the number in row one. The third row will allocate space for the number indicators, which will be hanging on the white board and hung onto the paint line when needed. The white board is designed to hold information for a maximum of 20 load carriers. With a throughput of

500 parts per day, 8 hour work day and a cycle time of 90 minutes, the average amounts of parts loaded on the paint line is calculated below:

$$\text{Average loaded parts} = \frac{500}{8} * 1.5 = 94 \text{ parts}$$

The current design can handle the label information of 20 load carriers, which will result in approximately five parts per load carrier. However, these simplified calculations are subject to great variations. It is very unlikely that the paint line will be subject to an average of five parts per load carrier; however the design will be able to handle this extreme situation. Also, since the investment is minimal, the fact that 20 locations will provide flexibility and the importance of a non-broken information flow, the decision is regarded to be justified.

The conceptual design of the earlier mentioned number indicator is visualised in figure 7.8 below.

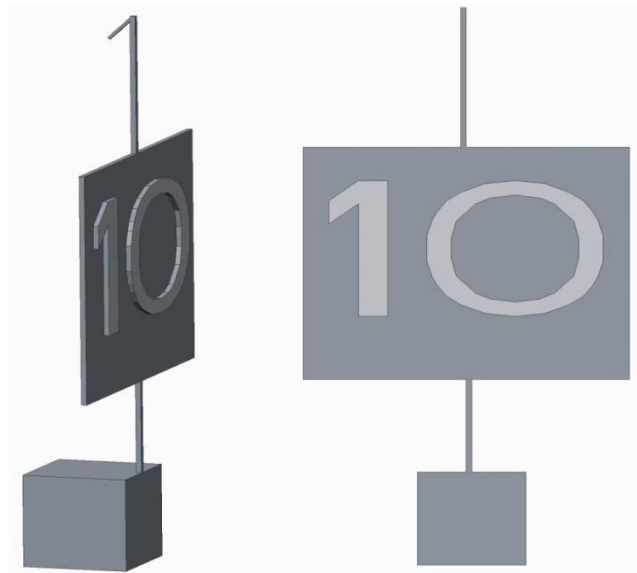

**Figure 7.8** The proposed conceptual design for the number indicator of the sub-system

The number indicator consists of three parts, a hook, a number plate and a weight. The total height is 150 mm divided into the three segments. The number plate has a width of 50 mm. The critical dimension is the height; if the indicator hangs too low it could get painted. The authors have done measurements which indicate that a height of 150mm will not be subject to paint. However, since the paint line utilise a powder coating paint process, some paint could stick to the indicator due to an unpredictable air flow. Company A should run trail runs to ensure an even more accurate height of the indicator. The weight is needed to ensure that the indicator does not come off the paint line when going through the four processes, visualised by the layout in figure 4.2. Only a small weight will be necessary since relatively small parts that are being



painted can withstand the conditions. The number should simply be painted on the plate.

To complete the system a few standard work procedure needs to be established, the procedures are listed below:

- When the process of hanging parts onto the paint line from a load carrier starts, a number indicator should be hung in the same position as the first part.
- Labels from the load carrier should be attached to the white board with the magnetic number that corresponds to the number indicator utilised.
- If the load carrier has more than one label attached to it, the operator should group these together and attached them with the magnetic number that corresponds to the chosen number indicator. This to assure that the parts will end up together on one load carrier.
- When a number indicator reaches the off loading dock, the operator should retrieve the indicator and return it to the correct location on the white board. When it is returned, the operator should collect the labels that correspond to the number of the indicator returned. The operator should attach the labels to the load carrier, and the parts can be offloaded.
- When the operator is offloading parts, he or she will know that a new load carrier should be utilised when the next number indicator is arriving on the paint line, and repeat the previous standard work procedures.

With the established labelling system and standards work procedures, load carriers holding WIP should have the correct information attached in order for the picker to efficiently pick the required painted parts for jobs in the assembly function.

In the simplified flow chart, figure 7.2, four label printing stations have been placed, one for each function in the metal shop. Since the natural flow in the metal shop is fairly slow due to the process choice of batching and the processes themselves. The tracking system will not be subjected to any congestion due to this reason, hence four stations is regarded sufficient to enable a smooth labelling process within each function.

The investment cost for hardware and software for one station is visualised in table 7.6 below.

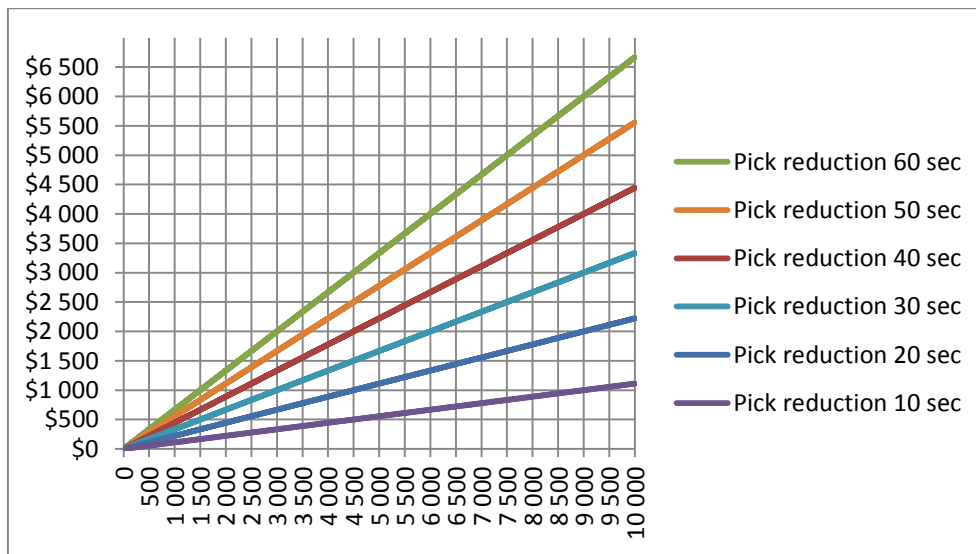

**Table 7.6** The proposed hard- and software to invest in and associated costs

BarTender software <sup>203</sup>	label	Zebra Stripe Printer <sup>204</sup>	S4M	Symbol bar scanner <sup>205</sup>	LS2208 code	Stationary Server and LCD screen <sup>206</sup>
\$250		\$770		\$130		\$115

The total investment cost for four stations is approximately \$5000. Adding to this is an implementation cost for installing the stations and producing label holders, indicators and the white board. However, this part of the investment is considered to be minor in comparison to the main investment of the label stations, and is therefore not quantified.

If the system is successfully implemented and utilised Company A will see improvements such as reduction of defects and mistakes due to better control of the work environment. In addition to this, Company A will benefit from savings related to the main objective of supporting pickers with visual information. Lack of data makes it hard to quantify and precise the savings. Visualised in figure 7.9 is the potential savings from increased picking efficiency.



**Figure 7.9** Potential yearly savings corresponding to six various outcomes of pick time reduction. The Y-axis visualise the potential yearly savings and the X-axis show the corresponding amount of picks. Equation utilised:

$$Savings = average\ time\ reduced * picks * cost\ per\ hour$$

<sup>203</sup> Company A, IT department

<sup>204</sup> Barcodescannersdiscount.

<sup>205</sup> Barcodesinc

<sup>206</sup>Geeks

Calculations are based on the standard hourly cost within the assembly function of \$40 and time reduced per pick is considered as an average. Data extracted from the MRP system show a total of 8900 pick lines generated for painted parts in the SFGI. However, the generated pick lines do not exactly correspond to the amounts of picks in reality. For instance, three lines could be picked at the same time if the parts are located on the same load carrier resulting in one pick for three pick lines, and the opposite to this is a pick line for a quantity or volume greater than the load carrier capability which will result in multiple picks for one pick line. This uncertainty is the reason to conduct the sensitivity analysis visualised in figure 7.9, where upper and lower boundaries have been accounted for. To what extent pick times will be reduced is hard to quantify. Reduced time would mean reduced distances to walk and reduced time for inspecting WIP to make sure the correct items are picked. Simply to walk across the paint shop floor takes approximately 20 seconds. Figure 7.9 show the possible outcomes for pick time reduction, in the interval of 10 to 60 seconds.

In addition to increased picking efficiency, the amount of wrongly kitted jobs will be reduced and hence the risk of standstill at assembly lines will be reduced. WIP can look very similar due to the nature of the product design. It will be a lot easier for the picker to distinguish WIP by numbers than by product knowledge. Furthermore, the same argument will increase employee flexibility since identifying WIP by numbers can be done by anyone. Productivity will be exposed to less variability if employees are sick, on holiday or leave the company. Quantification of savings in regards to reduced standstill and wrongly kitted jobs has been conducted in the same manner as the quantification of picking efficiency. In figure 7.10, the yearly potential savings for reduction of wrongly kitted jobs is visualised.

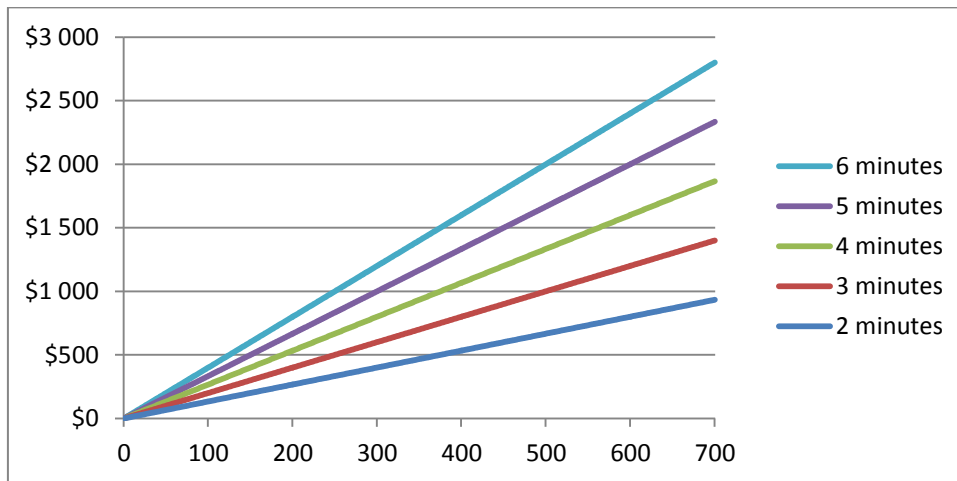

**Figure 7.10** Visualised on the Y-axis is the potential yearly savings and on the X-axis is the potential yearly reduced amount of wrongly kitted jobs. Calculations are based on the average time it takes to resolve the issue of wrongly kitted jobs. *Savings = average time spent to resolve issue \* reduced number of incorrect kitted jobs \* cost per hour*

The time spent to resolve these issues vary and the chosen average times represents the time to pick the correct part, return the incorrect part and to communicate the issue. The chosen interval of average time spent to resolve an issue should be considered as an assumption and are based on the time standard work procedures take to conduct. This, since the authors have not been able to collect accurate data when an issue of a wrongly kitted job occurred. Furthermore, the yearly potential savings of reducing the frequency of standstill in the assembly is visualised in figure 7.11.

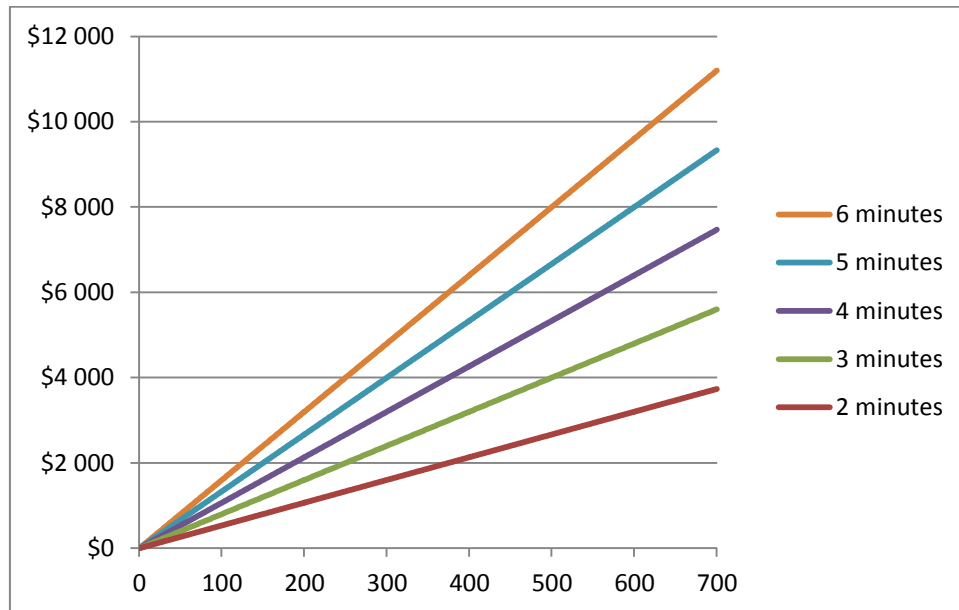

**Figure 7.11** Visualised on the Y-axis is the potential yearly savings and on the X-axis is the yearly potential frequency of standstill reduced.

$$\text{Savings} = \text{average time of a standstill} * \text{reduced frequency of standstill} * \text{cost per hour} * \text{nbr operators}$$

The cost of a standstill is based on four operators per assembly line and Company A's hourly cost of \$40 in the assembly function. The average times of a standstill should be regarded as indicators of the potential and have no ground in collected data. However, the authors consider the interval as a good guesstimate of average standstill based on the observations of the workflow during the VSMS.

In an attempt to quantify the frequency of standstill and wrongly kitted jobs, some guesstimates were obtained through conversation with the supervisors in the assembly function in order to utilise their work experience. The guesstimate was that 7.5% of the weekly throughput of jobs is subject to standstill and wrongly kitted jobs, directly affected by the picking of painted parts. Internal data show that the throughput of jobs the last twelve months was approximately 4700. This would result in approximately 350 occasions over the period of a year.

As stated earlier, these savings should serve the purpose to visualise the potential impact of the suggested visual control system utilising bar code labels. However,

since there are other benefits than the potential savings such as reduced defects and mistakes, employee flexibility, reduced variability of productivity, the authors propose to that Company A should invest in the system.

Company A promotes a three year pay-back time. Considering the potential savings discussed, the authors believe that there is a high success rate of a return on investment within three years or less. For example, the lower boundary of an average of two minutes per standstill and the guesstimate of 7,5% standstill frequency, will itself return the investment in three years.

Implementation should begin at the most critical point which is in the paint shop, assuring that the sub-system is functioning as expected since failure in this area will result in a mismatch of information and WIP regardless of the success of previous processes. Prior to the implementation of the print and scanning stations, all load carriers should have been prepared with label holders. The designed label holders will be applicable on pallets; any other load carrier that might be utilised should have some type of pocket in order to hold labels. Implementation of the print and scanning stations should start when the sub-system is successfully implemented and when all load carriers have a label holder. Since the same bar code scanning software is utilised at Company A today, in a different function, the knowledge on how to manage the software is already in place. Therefore, this part of the implementation should not be subjected to any major issues. Company A should clearly communicate the change and what is expected from the employees prior to the implementation to ensure a smooth and rapid implementation. Some type of simulation should be conducted with pre-printed labels in order for the employees to get a greater understanding of the new system and start the learning curve prior to the implementation. Since there is no tracking system in place today, Company A must be prepared and allow for a learning curve to take place.

#### **7.4 Department Lack Orderliness, Structure and Standard Work Procedures**

The vision for the metal shop is to have an implemented 5S system in place that is sustained and continuously improved. There are many steps to take in order to reach that vision and it should all start with a thoroughly developed system launch plan. The result of a failed launch could mean that the employees lose faith in the concept and any further attempts to implement a 5S system will be met with resilience.

Before any attempt is made to implement the 5S system, the employees need to be educated on the meaning and advantages of a 5S system. The mantra of Sort, Straighten, Shine, Standardise and Sustain, needs to be explained in detail as well as the importance of executing all 5S in order to reach the gains of a 5S system. It should be educated in a way that relates the 5S' to the employees work procedures. This to assure that Sort, Straighten, Shine, Standardise and Sustain, are not merely words, rather a way of how to carry out their daily activities. Employees should be asked questions on their view of the workplace and what improvements they believe would make it better. This will act as a gateway into the mindset that the employees should not simply accept the current situation, rather utilise their own expertise on

how to improve it, which is the objective of the 5S system. The education should be conducted in a manner to show that a 5S system does not implicate more work rather that the right work is done and work is done right. The goal is to get every employee on board before the implementation is started.

In order to induce responsibility and sense of ownership, the metal shop should be broken down into several 5S areas, visualised in figure 7.12, that will be managed by two teams, green and blue.

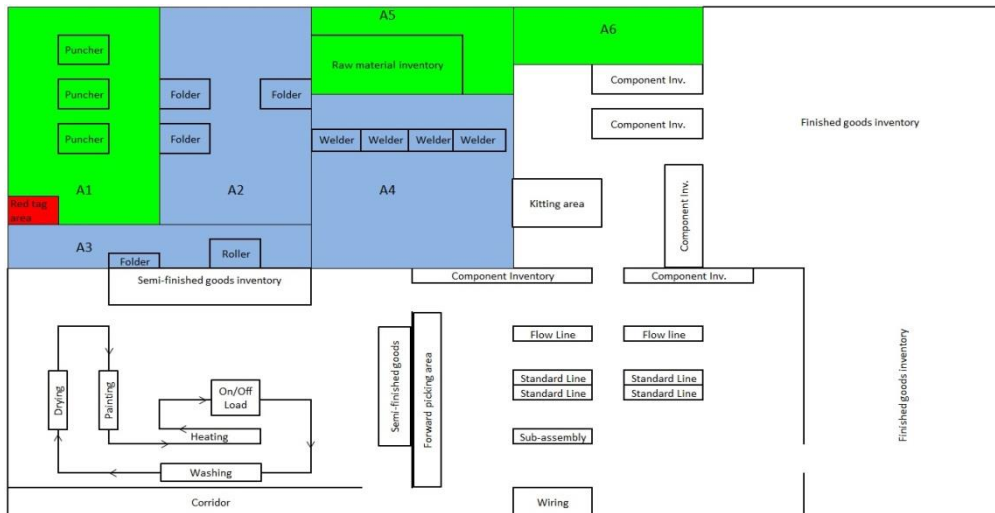

**Figure 7.12** A proposed distribution of areas for the 5S teams

These areas should be highlighted with coloured marking tape to clearly indicate the designated areas. The areas should be distributed amongst the teams according to where the team members conduct their daily work. For example, if employees A, B and C usually reside in A2 conducting folding operations, see figure 7.12, this area should be their responsibility. This is a simple example and flexibility is obviously needed. However the reasoning is the same, areas should only be distributed to the teams that conduct work in that area. The two supervisors in the metal shop should act as 5S team leaders and should be responsible for one team each.

When 5S teams have been established Company A needs to develop a detailed launch plan on how to conduct the 5S'. It is proposed that the 5S implementation should follow the PDCA cycle, explained in chapter 3.5.1, hence Company A should start implementing the 5S system in the metal shop and if successful further expand it to all functions of the Company in the future. Company A should start with the areas with the highest potential impact to gain further support of the 5S system from their employees.

Propositions on what to carry out for each of the 5S' at Company A are listed in table 7.7 below.

**Table 7.7** A simplified walkthrough of activities for the 5S'

5S	To be carried out
<b>Sort</b>	Sort through items, red tag all tools, jigs, WIP and consumables that are rarely or never used to preform value adding activities and remove from work area. Remove load carriers and excess WIP inventory that are never used and throw away what is obvious scrap.  Everything that has been red tagged should be put in a red tag area. Sort through all items and return items that are considered useful to their proper work area and throw away items that are considered obsolete.
<b>Straighten</b>	Create permanent locations and label them for all tools, jigs, consumables and other items that are needed to perform value added work. Most frequently used should be easiest to obtain.  For example tools in a box with shadowed locations or create a shelf to increase organisation of production orders.
<b>Shine</b>	This step is all about cleanliness. Make sure the right cleaning items are available for the work area. Is there a need for additional rubbish and recycling bins?
<b>Standardise</b>	Establish standards to sustain the first 3S'. For example establish routines for when a shift ends and routines on how to manage the introduction/exclusion of tools, jigs, consumables etc. in a work area. Define how the workplace should look like.
<b>Sustain</b>	Conduct audits regularly for all areas. Develop a scoring system based on what is deemed most important within the 5S'. Clearly visualise the score in the work shop. Use incentives such as rewards for highest score to sustain the commitment and further development of the 5S system.

These propositions should be regarded as a starting point for Company A. Since the first 3S' are dependent on the specific work area, the authors regard these propositions as sufficient. The fourth S, standardise, is most effectively developed during the implementation of the 5S system since the employees expertise can be utilised as issues are visualised. Therefore specific standards for each work area has also been disregarded to an in depth proposal for the specific areas. The remainder of the analysis will focus on general standards for the whole metal shop, how to sustain a 5S system and development of supporting tools.

After completion of the first 3S', a support system where designated areas have been highlighted, locations labelled and dedicated places for every tool, jig and consumable should be in place. To complement the support system some standard routines should be established:

- **End of shift standard routine**
  - Sort, red tag and remove unnecessary items for the workplace.
  - Assure that everything is placed in its proper location.
  - Clean up the workplace.
  
- **Red tag process** – Employee should utilise the red tag shown in Appendix D, when a decision has been taken to remove an item from the workplace. Red tagged items should be placed in the red tag area at the end of each shift. All items in the red tag area should be processed continuously or at least once a month to ensure that it does not grow into a big pile of rubbish. When a decision is taken on what to do with an item in the red tag area, the red tag documentation form, shown in Appendix D, should be filled out.
  
- **Monthly audit and scoring** – An audit should be conducted once every month to ensure that the standards are followed and to remind the employees that the company consider the 5S system to be of high importance, as discussed by Liker in chapter 3.5.5. Considering the size of Company A's metal shop the audit will not be too much of a time consuming activity. The auditor, preferably the production manager, should utilise the standard audit spread sheet, visualised in Appendix E. Since auditing is relatively subjective, it would be preferred that the audits are conducted by the same employee at all times in order to have somewhat comparable results. Also, some best practise examples have been included in the audit spread sheet to aid scoring. The team with the highest score should be rewarded and the score itself should be visualised through charts and updated in the work shop.
  
- **Quarterly 5S activity** – A workplace is subject to change at any given time. To assure that the 5S system is continuously improving and adjusted to new work patterns and environments, a greater 5S activity should take place on a quarterly basis. If the daily work routines are followed, this activity should not be too time consuming. Allow for some time to sort through generated ideas, discuss and get feedback from employees on possible improvements. Post decided improvement projects on a continuous improvement board to communicate ongoing changes to the employees. The 5S activity will expose abnormalities and assure that the 5S systems standards and work procedures are up to date.

A 5S system needs to be well communicated throughout the metal shop; this is best done through visual communication. 5S boards should be strategically placed throughout the metal shop communicating information on the 5S mantra, continuous improvements, score & rewards and on relevant KPIs such as Scrap rates and Safety. A proposed design on how to communicate the mentioned information is visualised in

Appendix F. These boards will act as reminders and incentives for the employees, with the objective to make the 5S' a work habit rather than rules.

Implementation should be carried out by all employees in the metal shop and be led by the production manager and supervisors. The reason to involve everyone in the implementation phase is that it will act as a 5S training session and employees will learn by doing, a method that corresponds with the fourth pillar of Lean, problem solving, discussed in chapter 3.4.2.4. Implementation should be carried out one S at a time and for all functions within the metal shop. Due to the small size of the metal shop this way of implementing the 5S system is deemed manageable. It should be stated that for a larger manufacturing unit, the 5S system is better implemented one function at the time. This since, if too much time passes between, for example, a sort event and a straighten event, it is likely that the sort event was in vain since there are no procedures to sustain it. It is advised to create an implementation schedule for the first three S' and develop the fourth S during the implementation phase with specific standards for each area. The schedule should be visually communicated in the metal shop in order for all employees involved to be prepared. To sustain the 5S system, Company A should utilise the developed audit tool and conduct monthly audits. In addition to this, a greater quarterly 5S activity should be carried out and the 5S activity board proposed should be visual in the metal shop. Finally, the implementation of the 5S system will set the foundation of the system and should be continuously improved indefinitely. However, the longer Company A practice the 5S' the more it will become a work habit and audits and greater 5S activities can be conducted less regularly.

A 5S system will induce many benefits when implemented and managed properly. Discussed in chapter 3.5.5, are the most common benefits a Company will enjoy from a 5S system. Company A will see improvements in all these aspects in the long run when successfully maintaining and improving their 5S system. After the sort and straighten events, the immediate impact will be improved efficiency. This due to the high potential of improved orderliness of tools, jigs and consumables to better suit the value adding activities. Discussed in chapter 4.2.1.4, is the issue of space getting scarce due to lack of standard work procedures and orderliness. A well maintained and practiced 5S system will ensure that space will not be wasted by scrap and unneeded items lying around in the workplace simply because standard work procedures are developed to prevent it. Also, a workplace free of scrap and dirt, and where employees easily can obtain the needed items to perform their daily activities will be a more pleasant environment to work in. Whatever improvements the 5S system will bring Company A it will enable another great aspect, building a culture of continuous improvement, employee development and utilising employee creativity, which will support Company A to be an even more competitive player on the lighting market in the future.



## 7.5 Product Designs are not Fully Optimised for Manufacturing and Assembly

This analysis is performed to show the gains that can be made for the company by applying the DFMA methodology on their product designs. The analysis will be performed on one of the company's products that will act as a generalised case to show the potential of the methodology and associating tool. The authors have chosen Product I, visualised in figure 7.13, because it is one of the most time-consuming product families to assemble and it is also a common product sold by the company. An improved design could have a noticeable impact on the efficiency of the metal shop and assembly. Its time-consuming assembly is largely due to its high IP-rating, which describes the degree of protection against solid objects as well as moisture and water that is required by the product. Because of this high rating, it is required that the fitting's internal components are safely protected through a well-sealed frame and body design.



**Figure 7.13** Product I

Next, a good understanding of the product's manufacturing and assembly process along with the product's BOM is needed in order to be able to implement the methodology properly. The authors' observations that were done through the VSM, hands-on experience on the assembly lines, and interviews have given them a good understanding of these processes and greatly helped them in this stage of the assessment. The authors observed the assembly process of the chosen product again in order to fully understand all of its fastening and insertion steps and to note all consumables used, since most these are not included in the BOM. These are, together with all components in the BOM, examined and incorporated into the worksheet seen in Appendix N.

Every component in the worksheet is assessed and their respective handling code and an insertion code is estimated through the Classification for Manual Handling and Classification for Manual Insertion and Fastening, seen in Appendix O. These are then summarised to a total assembly time and an assembly cost is calculated based on the assembly time multiplied with Company A's hourly standard cost. A material cost for every component is also obtained through the company's MRP system. These two costs are then used to finally calculate the product's total cost. The product's design efficiency, visualised in table 7.8, is also calculated through the equation found in chapter 3.5.7.

The total assembly time estimated with the methodology is evaluated against the company's own estimated assembly times on Product I in order to examine the accuracy of the methodology. The methodology's time estimation system does not take into consideration procedures that occur in between assembly operations or the fact that it can be divided up into sub-assemblies, as is the case of Product I, which requires the product to be transported between assembly stations. These delays will obviously mean that the real assembly time will be longer than the authors' estimated.

After the initial analysis of the product is done the authors use the DFMA rules to effectively reassess the design with the assembly and manufacturing processes in mind. A redesign of the fitting is done where assembly costs and material costs are defined in a table and an updated worksheet is created to show the effects of the redesign. The redesign also takes into consideration the DFM aspect by trying to decrease the need for the manufacturing processes deemed difficult and time consuming and instead identifies alternative processes deemed more efficient.

### **Assembly process of Product I**

Here follows the assembly procedures for the chosen product. The frame is placed on the workbench. Silicone sealing solution is first applied around the corners of the frame strips welded on the frame. The K19 diffuser is carefully fitted in the frame where the silicon was applied and on top of that the acry clear diffuser. A long frame strip is then pushed down and fastened to the welded frame strips by using an air pressure pistol to fasten three rivets into holes in both the frame strips, squeezing the two diffusers between the two frame strips, seen in figure 7.14 and 7.15 below. The frame is turned and a short frame strip is fastened with two rivets in similar manner as described above. The other long frame strip and then the other short frame strip are applied to finally secure the diffusers to the painted frame. Four torsion springs are put in place by placing their loops in the frame hooks and then using tweezers to bend the hooks and enclose the loops. The frame is then moved over towards the station where the body is assembled.

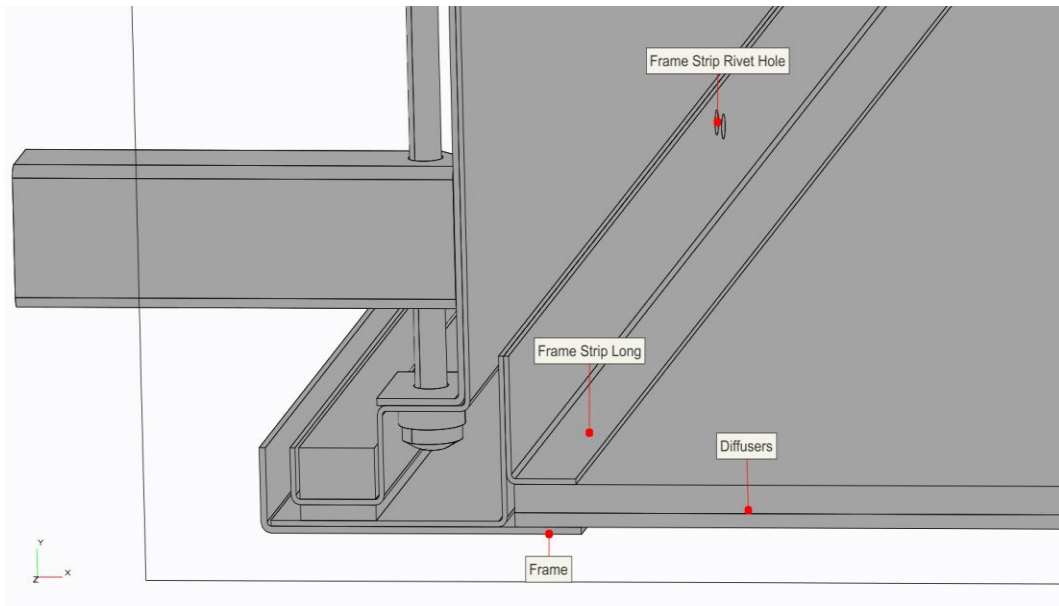

**Figure 7.14** Sectional view of Product I showing the frame, long frame strip, holes that the rivets are attached in, and both diffusers

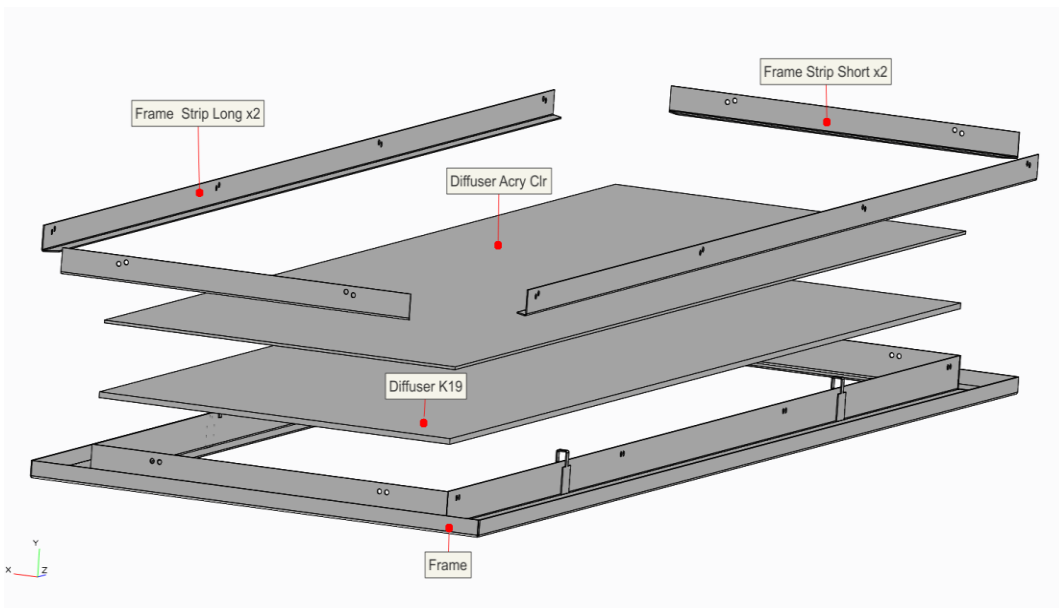

**Figure 7.15** Explosion view showing the frame, the four frame strips, and the two diffusers

The recessing arm nutserts are fastened onto the recessing arms with a power tool. The washer is placed in the recessing arm bolt, which is then put through the bracket

on the outside of the body and through the recessing arm and fastened with a nut, as seen in figure 7.16 below. This is done to all three of the arms on one side and then the body is rotated 180 degrees and it is done to the three on the other side. Silicon is applied to the corners and up the sides on the inside of the body. Gasket tape is applied all along the inside and then outside contour of the body.

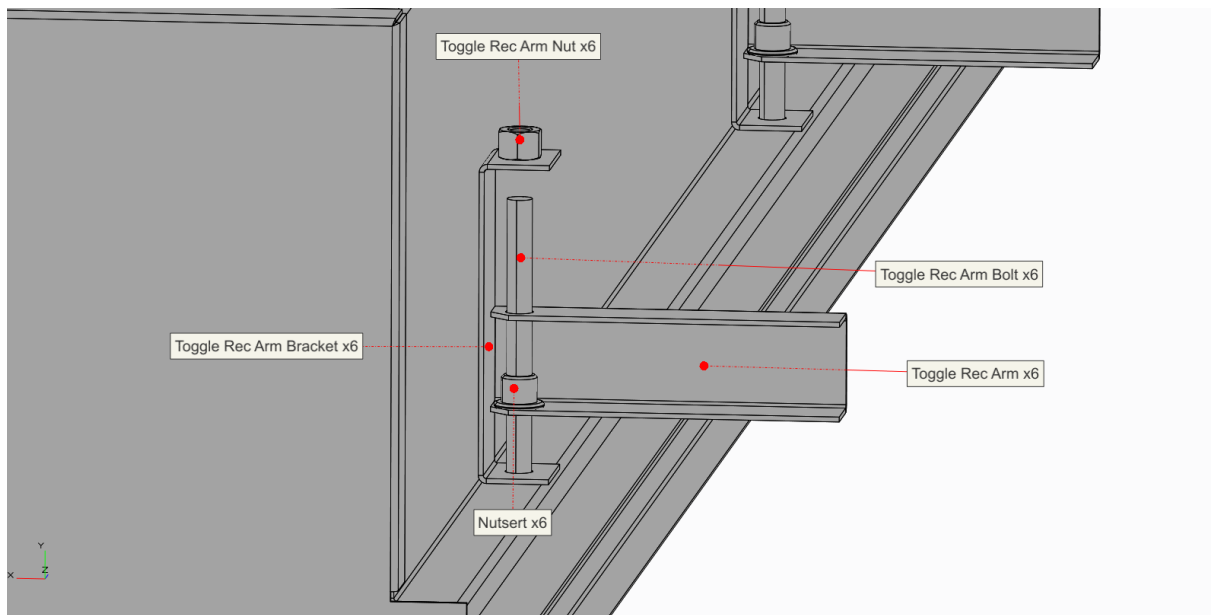
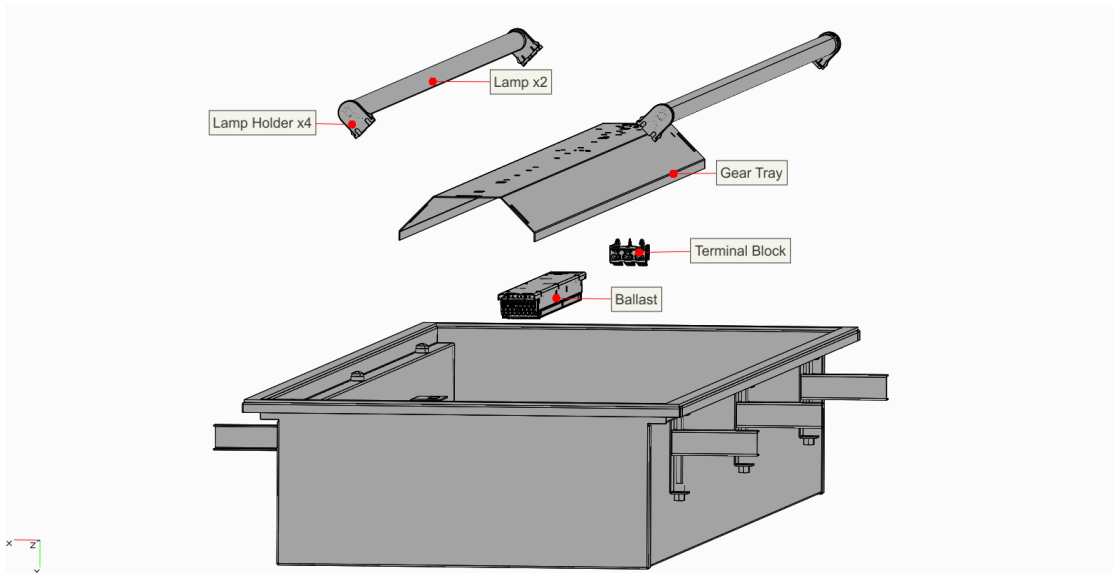

**Figure 7.16** View showing a recessing arm bracket, recessing arm bolt, recessing arm nut, and nutsert

The terminal block is snapped into the inside of the gear tray and then fastened with one screw using the power tool. The ballast is placed on the inside of the gear tray. Two bolts are inserted into holes at either end of the ballast and through the holes on the gear tray. The gear tray is turned over and two nuts are used to fasten the two bolts. The gear tray is turned over again and three wires are attached to the ballast from the terminal block. One wire each is attached between the four lamp holders and the ballast. The lamp holders are snap-fitted onto the gear tray from the inside. The components explained above, except for the wires, can be seen in figure 7.17 below.

The cable gland is attached to the hole in the body and tightened using a wrench with some difficulty because of restricted access inside the body. The gear tray is placed inside the body with the inside up. The flex and plug is inserted through the cable gland into the inside of the body and connected to the terminal block by screw fastening the wires. The gear tray is turned over and fastened to the body by screwing two screws through holes in the gear tray onto the Z-brackets on the body. Two lamps are attached to the lamp holders by placing their ends in the sockets of the lamp holders and turning them 90 degrees.

The frame is attached to the body by first inserting the two torsion springs on one side of the frame into the brackets in the body and then the two on the other side. All the components of the product can be seen in figure 7.18 below.



**Figure 7.17** Explosion view showing the body, lamp holders, lamps, gear tray, ballast, and terminal block

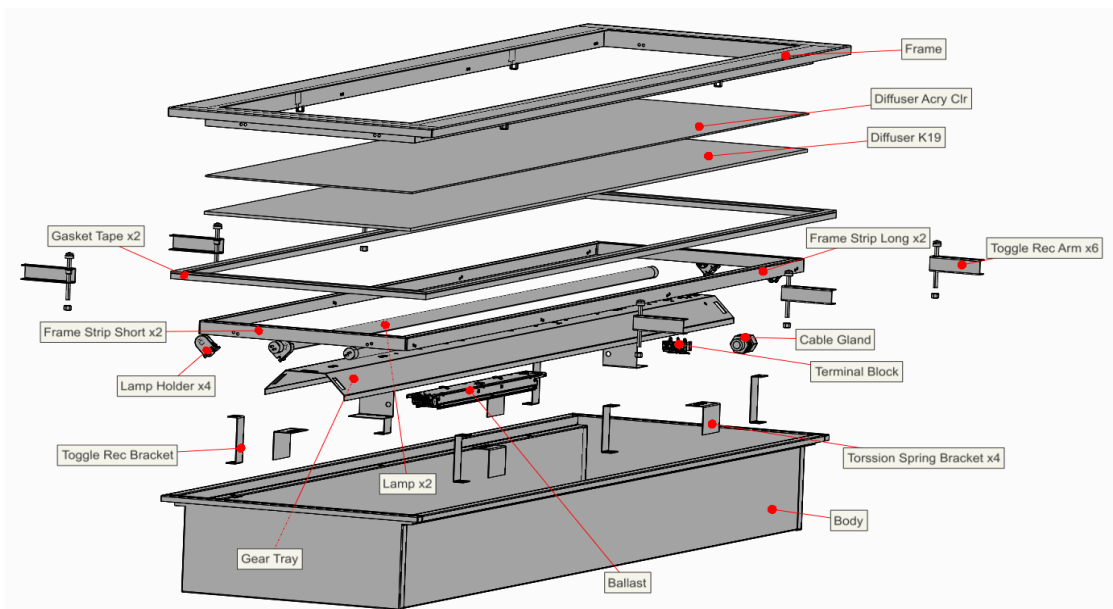

**Figure 7.18** Explosion view of Product I

## Estimated Cost and Design Efficiency of Product I

**Table 7.8** Estimated total cost and the design efficiency

Total Assembly Time (sec)	Total Assembly Cost (\$)	Total Material Cost (\$)	Total Cost (\$)	Design Efficiency
<b>709,56</b>	7,80	118,63	126,44	0,11

The estimated total assembly time is calculated to 709 sec or 11:49 min while the company's actual assembly times for the chosen product family range between 33-64 min.

Although the assembly times differ, the total assembly time obtained through the VSM where Product I's product family was followed, visualised in Appendix I, was 21 minutes. This is more in line with the times acquired through the DFMA methodology than those estimated by the company. The total cost of 126.43 AUD of the fitting calculated through the worksheet is fairly accurate compared to its actual price of 138.96 AUD. The assembly time is set to 47 min when Company A calculate the actual cost, which of course increases the cost. The calculated values can be seen in table 7.8.

The complete analysis worksheet of Product I can be seen in Appendix N.

### Design changes

The changes made to the fitting are developed largely by considering the three rules of the DFMA methodology. But in order to justify the possible design changes, the company's manufacturing capability also needs to be taken into consideration as the design is only as good as the production allows it to be. Also, the design changes produced by the authors might not be optimally suited for the light fitting that the analysis is performed on. This is due to the fittings IP-rating which puts very high requirements on the fitting's tightness and thus limits the design changes validity. The changes can on the other hand be used as inspirational fuel for the company on other product families that are not as restricted. Cost calculations are performed on the current design and on the redesign to show what impact using the DFMA methodology can have on Company A's production costs.

By studying the estimated assembly times on the worksheet the assembly can be broken down into smaller assembly processes and suitable design changes can be developed in a more manageable manner. Table 7.9 shows all critical segments in the assembly process of the chosen product and the proposed design changes made.

## Design Change 1.

**Table 7.9** Parts affected by design change 1

part number	number repeats	handling code	handling time (sec)	insertion code	insertion time (sec)	total assembly time (sec)	manual assembly cost (\$)	min number of parts	Remarks	material costs (\$)
4 Frame strip Long	2	30	1,95	00	1,5	6,9	0,0756		place in frame	6
5 Frame strip Short	2	30	1,95	00	1,5	6,9	0,0759		place in frame	4
6 Reorientation	1			98	9	9	0,099		reorient frame when fastening strips	0
7 Frame strip Rivets	12	15	2,25	36	8	123	1,353		fasten with air pistol	0,6

Replace the frame strips and rivets that are used to fixate the two diffusers with metal clips that lock onto the welded frame strips. These clips, seen in figure 7.19, need to have teeth to lock on to the strips and would need to be made in a non-corrosive material such as blue zinc or galvanised aluminium. Since they are of a simple design they could be ordered through a supplier. This would eliminate the need to use the puncher, folder, and paint line to produce them, saving time and costs in the process. The parts that will be affected by this design change are seen in table 7.9. Additional figures can be found in Appendix P.

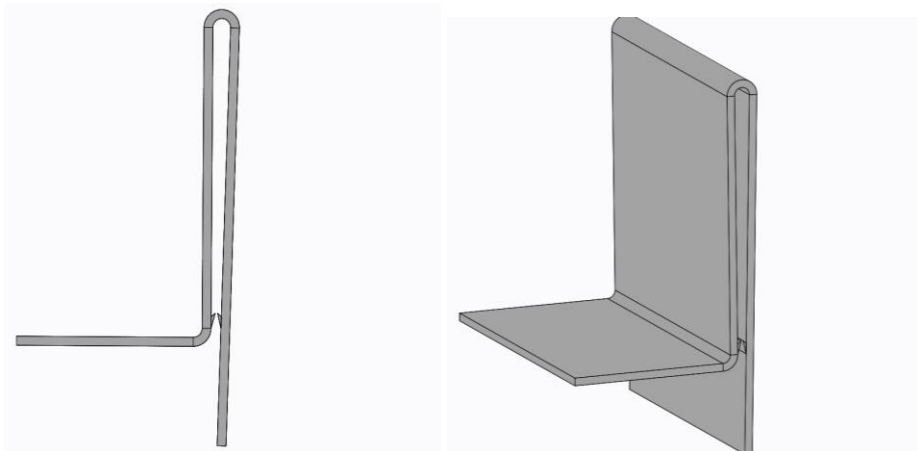

**Figure 7.19** Metal clip

## Design Change 2.

**Table 7.10** Parts affected by design change 2

part number	number repeats	handling code	handling time (sec)	insertion code	insertion time (sec)	total assembly time (sec)	manual assembly cost (\$)	min number of parts	Remarks	material costs (\$)
11 Toggle rec arm plug	6	11	1,8	30	2	22,8	0,25		fasten with power tool	0,3
12 Toggle rec arm washer	6	01	1,43	00	1,5	17,58	0,19		place into bolt	0,6
13 Toggle rec arm bolt	6	10	1,5	38	6	45	0,50		place into bracket and screw to arm	0,6
14 Toggle rec arm	6	30	1,95	00	1,5	20,7	0,23	6	placed in bracket	6
15 Toggle rec arm nut	6	01	1,43	38	6	44,58	0,49		nut fastened to bolt	0,3

Redesign the toggle recess arms to be manufactured in plastic or galvanised aluminium with threaded holes to eliminate their need to be painted in order to protect them from corrosion. This can reduce material costs, and will eliminate the nutserts needed since these could be replaced with integrated internal threads in the aluminium/plastic arms. Figure 7.20 below shows the redesigned arm and the original arm and nutsert.

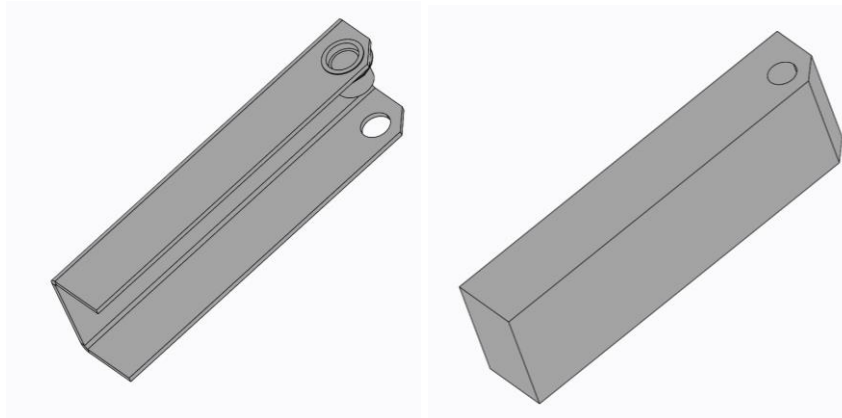
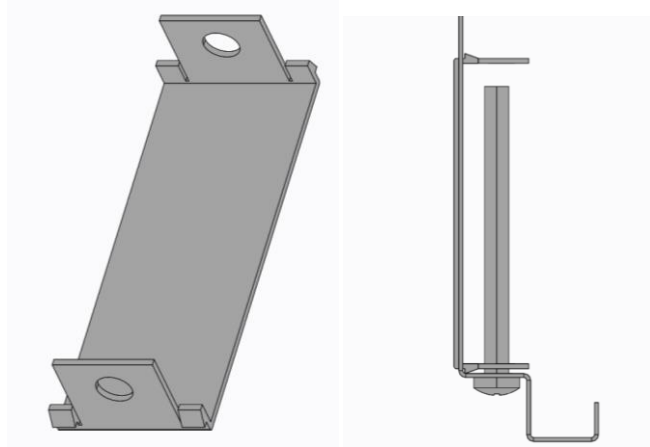

**Figure 7.20** The arm and attached nutsert (left) and the redesigned arm (right)

Redesigning the toggle recess brackets, seen in figure 7.21 below, to plastic snap-fitted brackets will also reduce material costs and eliminate the need for the welding process in manufacturing. Time will be saved throughout the metal shop since the toggle arms in the present manufacturing process have to go through punching, folding, and painting. The brackets have to go through punching, folding, and welding. By including the fastening of the brackets in the assembly process the



assembly time will increase. However, it can be assumed that this time is shorter than the processing time needed for the original brackets in the welding function. Also, decreasing from six to four arms will decrease assembly time and material costs. The parts that will be affected by this design change are seen in table 7.10. Additional figures can be found in Appendix P.



**Figure 7.21** The redesigned toggle recess bracket

The critical aspect of this design change lies in that the snap-fitted brackets will be able to support the tension that the fitting is exposed to once it is installed in the ceiling since its IP-rating requires it to be tightly situated. Utilising the designed snap fittings will also imply that holes in the body will be needed, a situation that could jeopardise its IP-rating if these are not properly sealed.

**Design Change 3.**

**Table 7.11** Parts affected by design change 3

part number	number repeats	handling code	handling time (sec)	insertion code	insertion time (sec)	total assembly time (sec)	manual assembly cost (\$)	min number of parts	Remarks	material costs (\$)
8 Gal torsion springs 1.8 mm	4	23	2,36	32	4	25,44	0,28		place in hook and bend with tweezers	1,96
9 Reorientation	1			98	9	9	0,10		move frame to next assembly station	0
10 Body	1	95	4	00	1,5	5,5	0,06	1	place on workbench	20
34 Frame	1	91	3	53	9	12	0,13	1	place and torsion fasten	15

Redesign the frame, seen in figure 7.22, to snap fit onto the body will eliminate the need for the four torsion springs, hooks, and torsion brackets. The frame’s long sides will wrap around the body on one long side, locking it into place, and the opposite side of the frame will have two bent “extensions” that will also wrap around the body, compressing the gasket tape at the same time. This will save time in the assembly, as applying the torsion springs to the frame is a time consuming process, as is the process of assembling the frame to the body. Eliminating the hooks and brackets will also eliminate the need for the welding and manufacturing process of these, which will save time and decrease material costs. Critical in this redesign is to ensure that the frame is still fastened to the body with equal or greater pressure to ensure the gasket tape is properly compressed. The parts that will be affected by this design change are seen in table 7.11. Additional figures can be found in Appendix P.

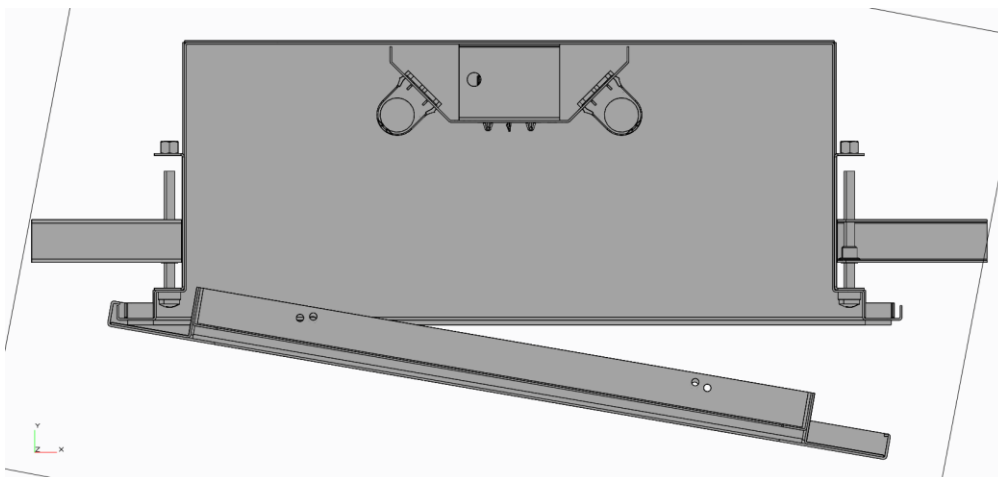

**Figure 7.22** Redesigned frame

Design Change 4.

**Table 7.12** Parts affected by design change 4

part number	number repeats	handling code	handling time (sec)	insertion code	insertion time (sec)	total assembly time (sec)	manual assembly cost (\$)	min number of parts	Remarks	material costs (\$)
<b>10 Body</b>	1	95	4	00	1,5	5,5	0,06	1	place on workbench	20
<b>31 Gear tray</b>	1	91	3	00	1,5	4,5	0,05		place in body	17,8
<b>32 Gear tray screws</b>	2	11	1,8	38	6	15,6	0,17		place and screw fasten	0,2

Redesign the gear tray to snap fit onto the body. This will eliminate the two screws and the Z brackets on the body, which would in turn eliminate their manufacturing and welding processes, decrease assembly time, and decrease material costs. The redesigned gear tray can be seen in figure 7.23 and 7.24 below. It is critical that the gear tray securely fastens and that the holes required for the snap fitting does not threaten the fitting's IP-rating. The gear tray will also need to be able to be properly fastened given the limited room in the body. The parts that will be affected by this design change are seen in table 7.12. Additional figures can be found in Appendix P.

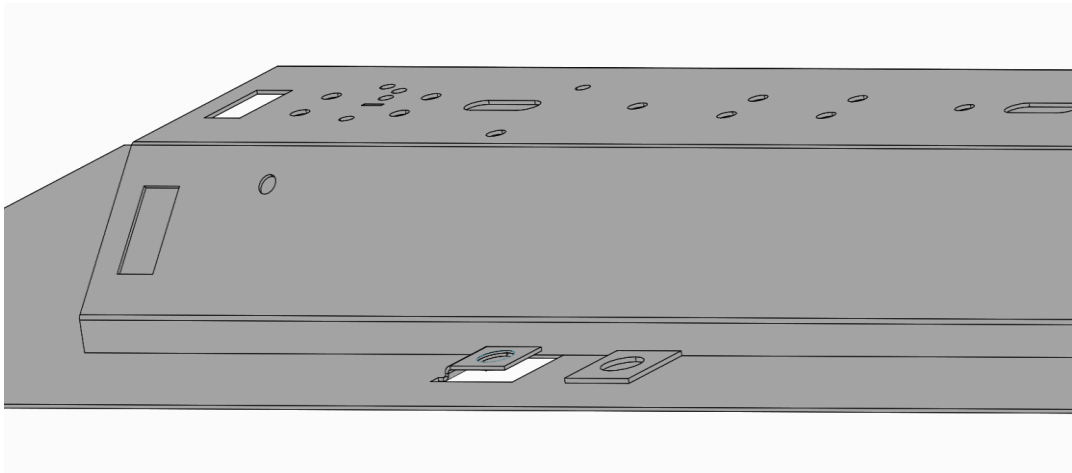

**Figure 7.23** Redesigned gear tray

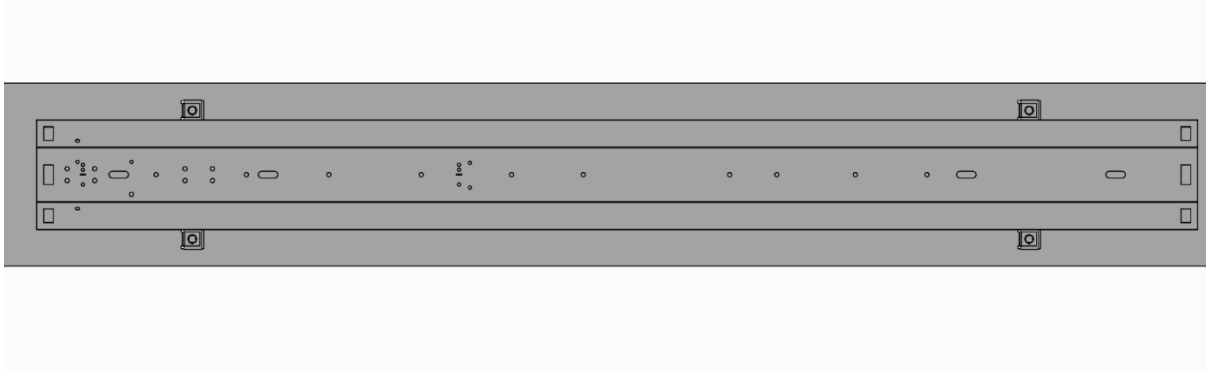

**Figure 7.24** Redesigned gear tray

## Design Changes 5 & 6.

**Table 7.13** Parts affected by design change 5 & 6

part number	number repeats	handling code	handling time (sec)	insertion code	insertion time (sec)	total assembly time (sec)	manual assembly cost (\$)	min number of parts	Remarks	material costs (\$)
19 Terminal block	1	30	1,95	30	2	3,95	0,043	1	place in frame and snap fasten	0,33
20 Terminal block screw	1	11	1,8	38	6	7,8	0,09		place in terminal block and screw fasten	0,1
21 Ballast	1	30	1,95	00	1,5	3,45	0,03	1	place on gear tray	6,31
22 Ballast bolts	2	11	1,8	38	6	15,6	0,17		place and screw fasten	0,2
23 Reorientation	1			98	9	9	0,10		turn gear tray over	0
24 Ballast nuts	2	01	1,43	38	6	14,86	0,16		place and screw fasten	0,2

Replace the bolt and nuts with plastic rivets, seen in figure 7.25, to attach the ballast, and eliminate the screw used to fasten the terminal block and instead have it snap-fit onto the gear tray. This will save time in the assembly and reduce material costs. Reassurance will still have to be made that the ballast and terminal block are securely fastened. The parts that will be affected by these design changes are visualised in table 7.13.

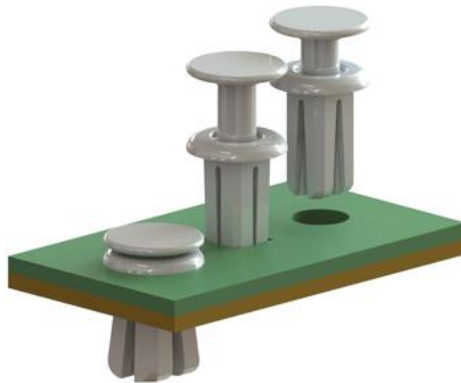

**Figure 7.25**<sup>207</sup> The functionality of a plastic push rivet

<sup>207</sup> Richco-inc

**Design Change 7.**

**Table 7.14** Parts affected by design change 7

part number	number repeats	handling code	handling time (sec)	insertion code	insertion time (sec)	total assembly time (sec)	manual assembly cost (\$)	min number of parts	Remarks	material costs (\$)
10 Body	1	95	4	00	1,5	5,5	0,06	1	place on workbench	20
17 Silicon	4			99	12	48	0,53		apply in and along corners of body	0,1

Apply tighter tolerances to the design of the body. This could eliminate the need for silicon sealing and save time in the assembly. An alternative solution can be to use a heat-activated or thermosetting sealing solution that will be applied to the body on the paint line and will use the oven as an activator. This solution can, however, prove to be problematic and would need to be thoroughly investigated, which can be hard to justify when considering the possible gains that can be made. The parts that will be affected by this design change are seen in table 7.14.

**Summary of Design Changes**

An updated worksheet is produced where all design changes are included and new estimations are produced with the help of the Classification System for Manual Handling and Classification System for Manual Insertion and Fastening. All design changes are summarised in Appendix Q. The new estimated total cost and the design efficiency can be seen in table 7.15 below.

**Table 7.15** Estimated total cost and the design efficiency after redesigns

Total Assembly Time (sec)	Total Assembly Cost (\$)	Material Cost (\$)	Total Cost (\$)	Design Efficiency
<b>412,04</b>	4,53	108,67	113,20	0,18

By summarising all the design changes the assembly time has been decreased from 709 to 412 seconds. A cost saving of over 13 AUD per fitting is also achieved along with an improved design efficiency of almost 60 %. The design changes involve replacing metal with plastic or with another type of material and could require outsourcing to do so. The redesigns also try to eliminate consumables and welding through a product design that can be assembled by utilising snap-fittings that fasten immediately.

There are other implications that are not as easily quantified as a result of these changes: The number of unique components in the product has been decreased which will streamline component data management. The decrease of unique components could also have a positive impact on inventory management. These impacts would become more apparent as the DFMA methodology is applied to more products. Ultimately, applying the methodology will result in reducing waste in the form of

over processing or incorrect processing, excess inventory, and defects as described in chapter 5.2.2.

## 7.6 Increase the Level of Commonality in Product Design

This analysis is performed to show the gains that can be made with an increased level of commonality in the company's product family design. Five products were chosen from one product family to be analysed. The Product family J is chosen, as it is a commonly sold product with a high level of differentiation across the family's products. The chosen products will vary in dimensions, number of light rows, and ceiling installation design in order to give a wide perspective of the product family. A summary of this can be seen in table 7.16 below.

**Table 7.16** The five chosen products of the analysis with information concerning the number of light rows, ceiling installation, and their dimension.

Product ID	# of light rows	Ceiling installation	Dimension
<b>J1-128-100-000</b>	1	T-bar	1200x300
<b>J2-228-100-000</b>	2	T-bar	1200x300
<b>J3-128-101-000</b>	1	Plaster recessed	1250x350
<b>J4-314-100-000</b>	3	T-bar	600x6000
<b>J5-414-100-000</b>	4	T-bar	600x6000

The products will be analysed using commonality theory and redesign suggestions will be generated across the five products. A commonality index tool, which measures the level of commonality between products, will be used to illustrate how commonality can be measured. The possible areas of improvement that could increase the level of commonality to the product family will be illustrated using CAD-drawings and the commonality index will afterwards be recalculated. The index will be used purely to quantify the possible increase in commonality that the design changes have made on the product family. Several commonality indexes were examined in order to find one suited for the analysis. More information about the different commonality indexes examined and about the chosen index can be found in Appendix U.

Below in figure 7.26 is an exploded view the J1-128-100-00 along with the corresponding component structure tree, seen in figure 7.27, in order to give the reader a visual idea of the product and its structure. The remaining four product's component structure trees can be found in Appendix S and exploded view images can be found in Appendix T.

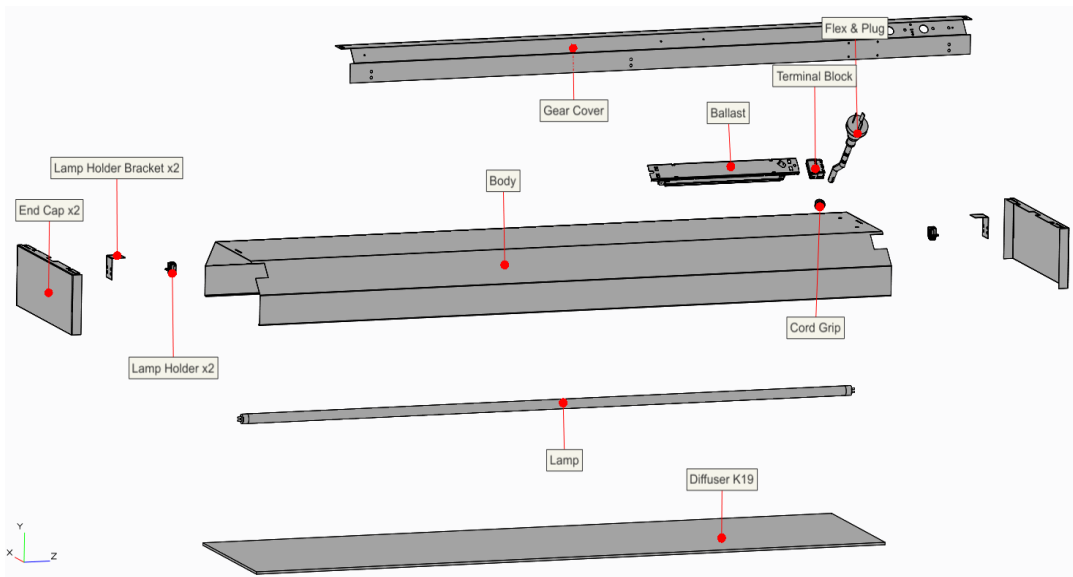

**Figure 7.26** Exploded view of J1-128-100-000

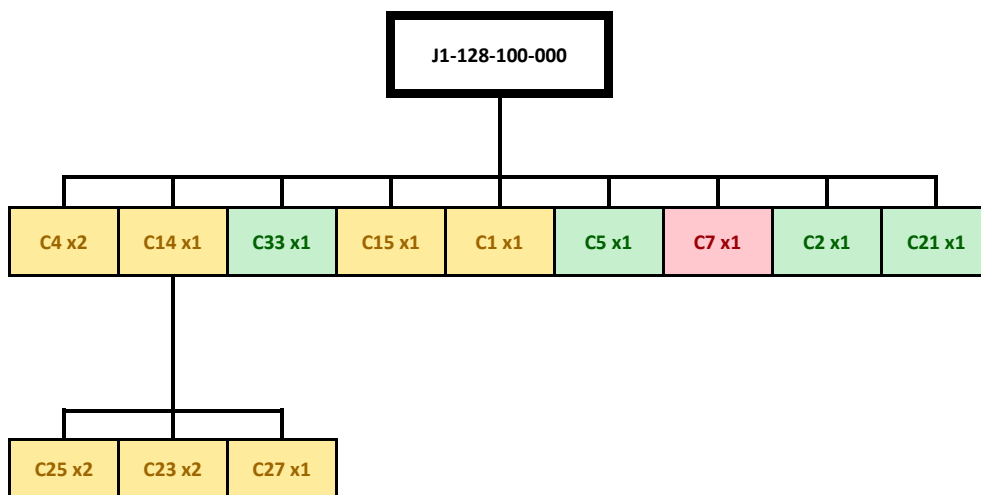

**Figure 7.27** Component structure tree of J1-128-100-000

An initial analysis of the five products divides them into two groups based on their similar dimensions. The calculation sheet used to calculate the commonality index is shown in Appendix R.

With the help of the chosen products' BOM, their component structure trees, component price data, and yearly volume data the commonality index is calculated to 1.75.



### Proposed Changes

With the help of CAD-drawings the five products were analysed and divided into the two groups based on similar dimensions. The three products in the first group all have a 1200x300 dimension but they are all produced using different bodies, end caps, gear trays/covers. Their bodies, gear trays/covers, lamp holder brackets, and lamps can be seen in figure 7.28 and 7.29 below. The gear tray/cover is fastened onto the side of the body on the J1-128-100-000, as seen in the figure 7.27 below.

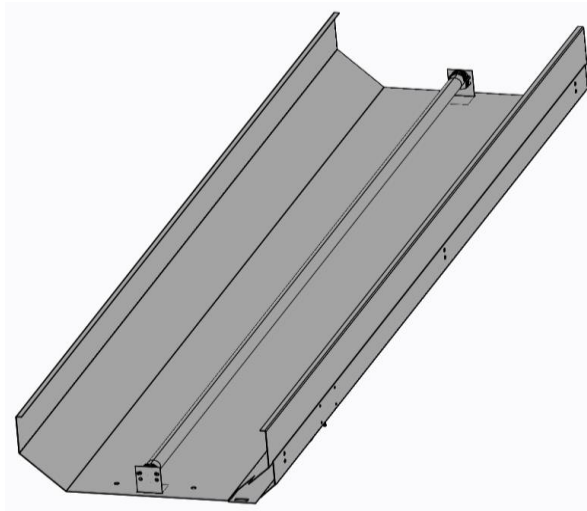

**Figure 7.28** Body, gear cover, lamp holder brackets, and lamp of J1-128-100-000

On the other two products the gear tray/cover is fastened in between the two light rows. The J3-128-101-000 also has several additional components that are fastened to it in the welding process or the assembly process, differentiating itself the most from the other two. Because of the J3-128-101-000's slightly different dimensions a different diffuser is also used for it.

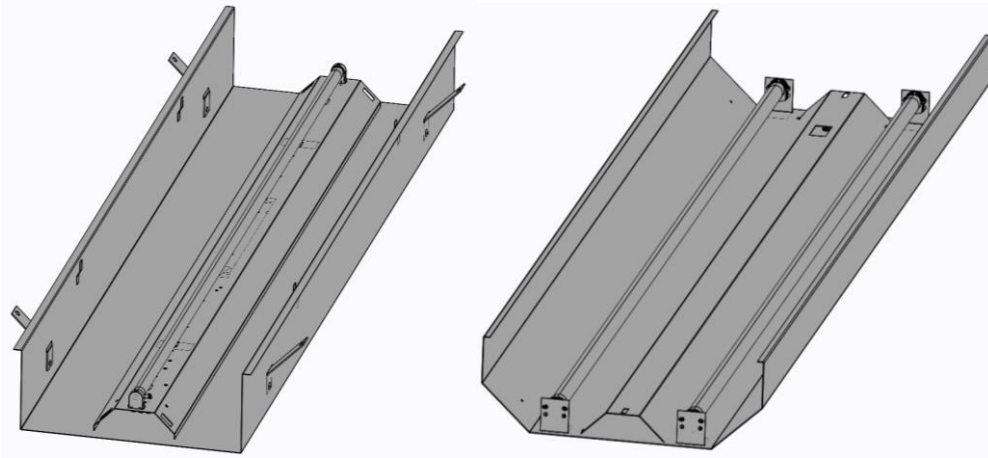

**Figure 7.29** Body, gear tray/cover, lamp holder brackets, and lamps of J3-128-101-000 (left) and J2-228-100-000 (right)

The two 600x600 products in the other group differentiate from one another through the number of light rows, different gear tray/cover, different bodies, and different end caps. The gear tray/cover is differently fastened on these in the same manner as described for the first group. Figure 7.30 shows their bodies, gear trays/covers, lamp holder brackets, and lamps

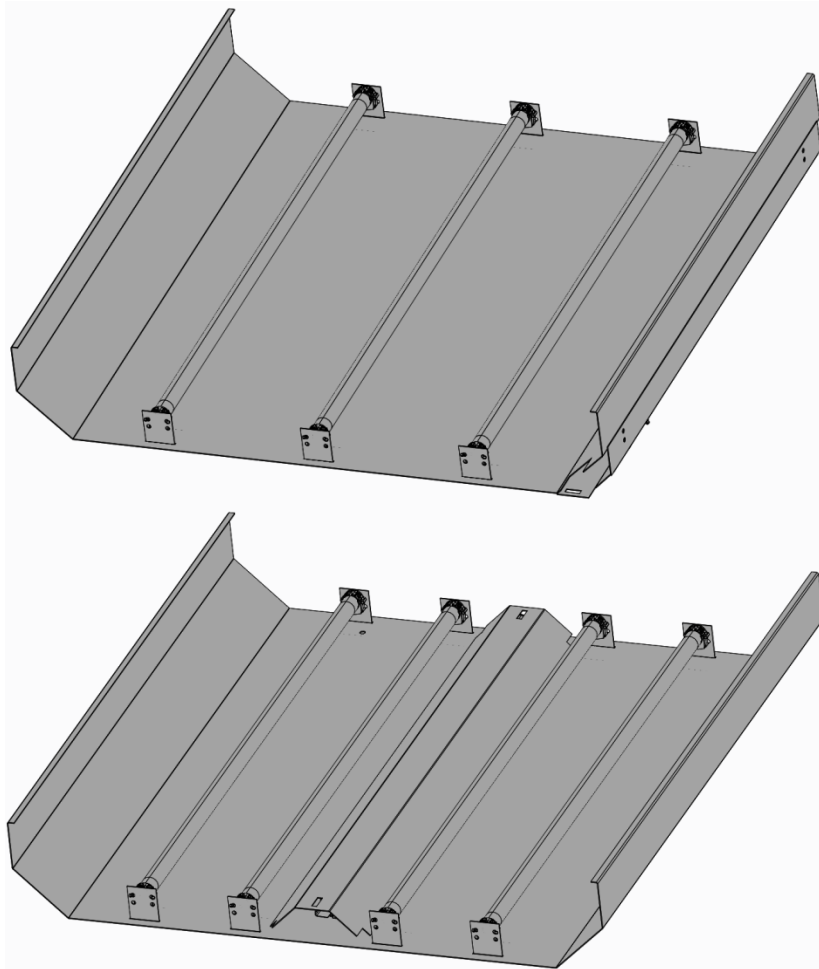

**Figure 7.30** Body, gear tray/cover, lamp holder brackets, and lamps of J4-314-10-000 (top) and J5-414-100-000 (bottom)

### **Design Changes in Group One**

The bodies of the three different fittings are integrated into one body that can fulfil all needed functions, seen in figure 7.31 and 7.32 below. The body has a 1200x300 dimension, since using the slightly bigger 1250x350 dimensions of the plaster recessed would add unnecessary weight and cost. This enables the end caps, the diffusers, and the gear trays/covers to be integrated into one type as well and allows the body clips to be discarded, seen on the image of the J3-128-101-000 in Appendix T. Holes are punched in the body in order for the lamp holder brackets to be attached. The lamp holder brackets that are fastened through welding in the old design are replaced with plastic brackets that are snap-fitted onto the body in the assembly. This allows the body to be modified to carry one or two rows of lamps.

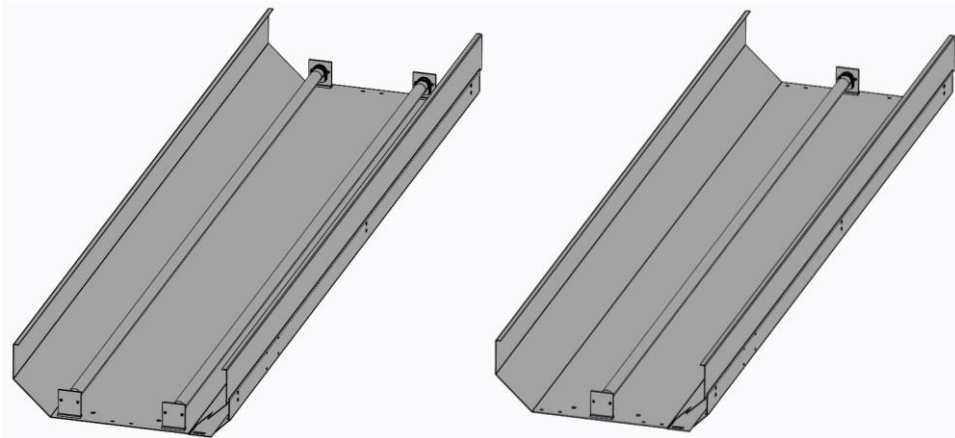

**Figure 7.31** Integrated body, gear cover, and one or two rows of lamp holder brackets and lamps

To modify the fitting for plaster recess requirements a frame and plaster mounting brackets need to be added to the fitting. These are simply welded onto the body. The brackets could also be replaced with plastic ones that are fastened in the assembly using snap-fittings. Additional images can be seen in Appendix V.

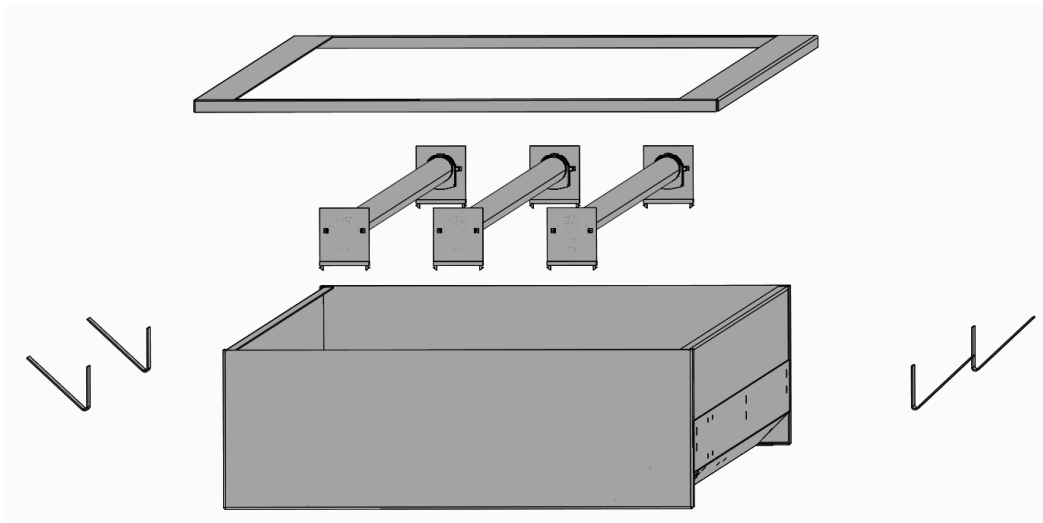
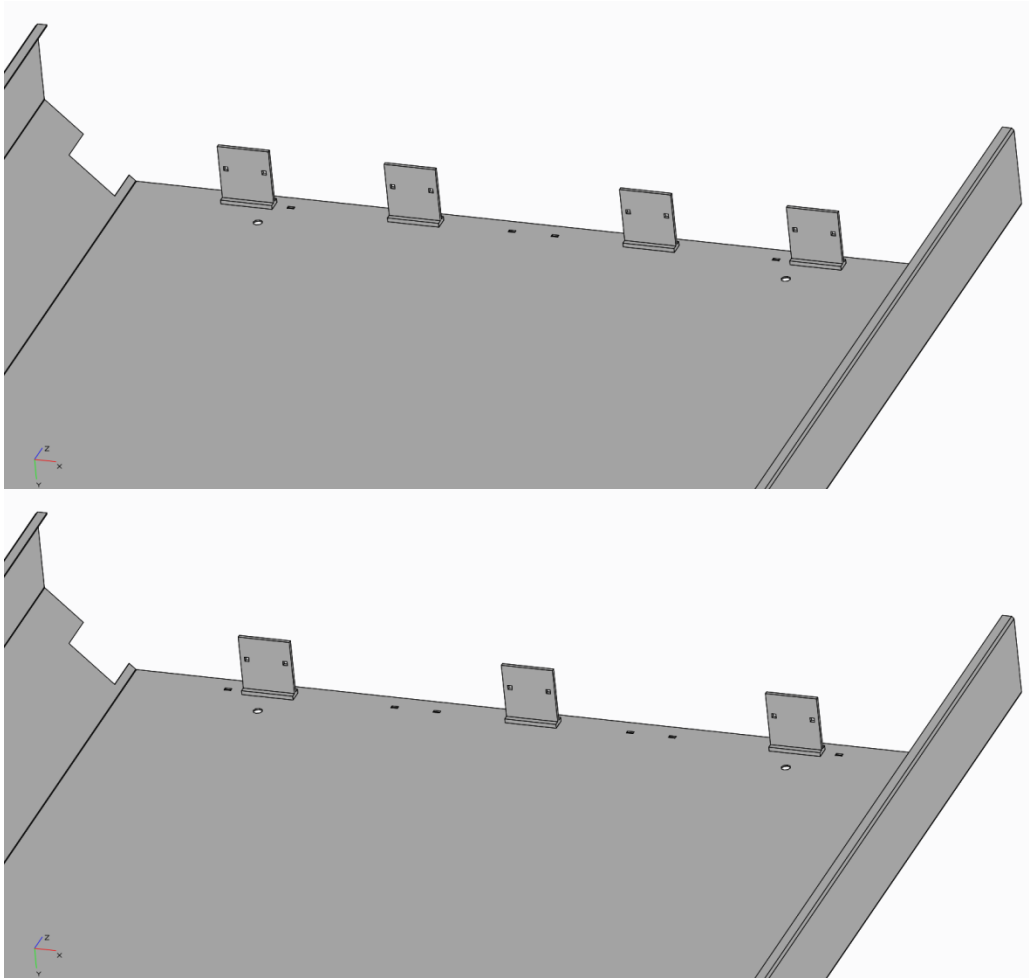

**Figure 7.32** Integrated fitting showing the different number of light rows that are possible, and frame and plaster recess brackets

### Design Changes in Group Two

The two fittings' bodies, end caps, and gear trays/covers are integrated into one in this case as well; in a similar manner as in group one. The lamp holder brackets are replaced with the same plastic brackets that were suggested to be used in group one, seen in figure 7.33 below. Holes are punched into the body so that the lamp holder

brackets can be positioned for three light rows and four light rows. This allows the differentiation of the products to be moved downward in the production to the assembly.



**Figure 7.33** Four rows (top) or three rows (bottom) of lamp holder brackets attached to the integrated body

## **Design Changes Summary**

By implementing the design changes described above five bodies, end caps, and gear trays/covers can be integrated into two. The body clips and the diffuser used for the plaster recessed are discarded. One dimension on the diffuser is only necessary for group one and one in group two. The plastic lamp holder brackets can be utilised in both groups and are fastened in the assembly process.

A new calculation sheet is produced with new components corresponding to the design changes made, seen in Appendix W. A new commonality index is calculated to 2.52, an increase of 44% compared to the old index. The number of unique components was reduced from 39 to 23, a decrease of 41%. It can be further argued that with economics of scale the component price could be reduced further which would increase the commonality index even more.

Increase in commonality can have a positive effect on the development process, reducing costs throughout the development or redevelopment of the product family and eliminating wastes as explained in section 5.2.4. The use of the same modules or components across several products entails that one common component only need to be developed or updated rather than several unique components. This can save large amounts of development time and costs. This is most likely where Company A will gain the most from increasing the level of commonality in product families. Fewer needed components would also mean reduction in the cost of database management and thus increase its efficiency, as its size would be reduced.

As explained in chapter 3.3.3.1 and 3.3.3.2: One should use the same components or modules between products if they do not add customer value and distinguish those that do give value. Between the J1-128-100-000 and J2-228-100-000, and the J4-314-100-000 and the J5-414-100-000, the distinguishable feature that gives customer value is the number of light rows and thus this should be the only distinguishable feature. The redesign integrates their bodies, gear covers, and end caps into one variant and allows the number of light rows to be customised further down in the production process. Allowing the differentiation of the product to be transferred down the production chain which increases the company's flexibility since changes to an order could be manageable by the production all the way to the final production process where the differentiation is finalised.

Quality problems that are caused by a high variety of different product designs are also decreased because using the same components for several products will increase the workers understanding of how that component is produced and thus allowing them to familiarise more with the components.

## 8 Conclusions and Project Evaluation

*Concluding remarks on the possible impact of the proposals will be provided to the reader in this chapter. The authors will discuss how this type of project could help business with similar challenges as Company A and some final reflections and feedback from the company will be provided.*

### 8.1 Project Results

The purpose of the thesis was to conduct a Lean study in order to increase the efficiency and flexibility of the product realisation process. The authors found 15 gaps that, if improved, could increase the efficiency and flexibility of the production system at Company A. However, due to the scope of the project only a few of these areas were subject to an in-depth study.

The outcome of the proposals developed is considered to be aligned with the stated purpose, however with varying potential. The proposals in section 7.1-7.6 will all contribute to either an increase in efficiency, flexibility or both since the work environment will reach a greater controlled state. With the established ILMS, Company A will gain better control of the raw material introduced into the production system since goods are inspected. This system will guard against inefficiency's such as unnecessary movement and transport, and defects. Also, it will enable continuous improvements with their suppliers in a controlled manner since supplier performance will be measured. In terms of flexibility, this will also be increased due to the detailed documentation and introduction of standard work procedures which will enable employee flexibility.

The proposal of utilising a structured SFGI will further increase efficiency since picking from a structured and standardised SFGI will be a lot easier when it is established what parts are held and where they are held. However, this proposal will deviate from the purpose since it will induce other major benefits such as decreased lead-times and reduced scrap rates. It can be argued that there might be a slight decrease in flexibility due to the fact that larger batches will be produced for the SFGI. However, the gains outweigh this slight decrease. Also, there will be some efficiency gains from reducing the total number of setups. Furthermore, introducing a SFGI will generate a third CODP at Company A which is assemble-to-order. Company A would have a mix of MTO, ETO and ATO which is considered to be better suited for the market they reside in.

Increasing the information flow will create a situation where the assembly function will reap the greatest benefits. The proposed system will induce a minor increase of

the work load in the manufacturing unit since they are the ones creating the information flow. The main benefits in the manufacturing function will come from a better controlled work environment and easier communicated information which will lead to a reduction of defects and mistakes. The main benefits will come from increased picking efficiency, reduction of wrongly kitted jobs and reduction of standstill in the assembly lines. This will allow for reduced setup times hence increasing the flexibility within the assembly function. Also, the system is developed to integrate flexibility of the information generation process. Furthermore, Company A will gain the benefit of employee flexibility since the information flow is based on number coding, enabling anyone to identify parts without product knowledge. These improvements are aligned with the purpose of the thesis since both flexibility and efficiency will be increased in the product realisation process.

The proposed 5S system will have more benefits than only increased efficiency. It will provide a platform for a cultural change in the manufacturing function as well as a more controlled and pleasant work environment. However, a cultural change takes time and Company A will most likely see the improvements in efficiency first due to a greater organisation of the items used to preform value-adding activities.

Implementing the DFMA-methodology on the company's products will increase the efficiency of the production system. By adapting the product designs to suit the manufacturing processes deemed advantageous by the company will eliminate bottlenecks, reduce material costs and reduce production times. Improving the assemblability will, beside increase efficiency, also improve the morale of the assembly as the products become easier and quicker to assemble.

Increasing the level of commonality on the company's product families will greatly increase the efficiency in the product development department since using less unique components throughout product families will reduce the number of components that need to be handled when updating product families to new generations. Reducing the number of unique components will also increase efficiency in the database system. An increase in commonality will also increase the flexibility in the production system as more of the same components are used over a wider product range and the differentiation of the product is moved further down in the production process. This allows orders to be changed as far down as in the last production process.

These proposals will improve the product realisation process by increasing the efficiency and flexibility as well as introducing other great benefits. The outcome from these improvements will enable Company A to conduct and manage their CODP in an effective manner. In an MTO environment it is crucial to have an efficient flow and a controlled production in order to sustain good service levels since the ordered product is not kept in stock. Furthermore, Company A provides their customers with the choice of changing their products to the specifications of the customer. With the introduced design technique of commonality, the product development department will be able to handle these requests in a more effective manner. Introducing the



CODP of ATO will enable Company A to be more competitive on the market since they will have a range of products that can be delivered with a short lead time.

Furthermore, these proposals will create a greater controlled environment as well as enable the product development process to be more efficient and flexible. Since the company already utilise a variant of the Stage-Gate model the authors consider that this process is carried out in a controlled manner as suggested in the product realisation process. However, the proposals developed will increase the efficiency and flexibility of it as well as provide for further focus on concurrent engineering to optimise the relationship between design and engineering and manufacturing functions.

The proposals for the production system will increase the control of the processes that the product passes through with a strong focus on increasing standardisation, organisation, and information and material flow.

These improvements are in line with the standards on product realisation; hence the authors suggest that the efficiency and flexibility of the product realisation process will be increased.

It is important that companies understand the implications of different CODP. There is no one right path to choose, the important aspect to consider is what the customers demand and how the company can satisfy this in the most efficient and flexible way in order to be profitable.

At the end of the project the authors received great feedback on their proposals. The company felt that it was in line with the needed improvements and believed that the results were valid. Implementation of the tracking system was deemed most important in order to continue implementing the other suggestions focusing on the production system. The product development function showed great interest in the utilised design techniques and felt that the proposals showed great potential for utilising them in future development projects.

## **8.2 Future Studies**

The proposed changes in this thesis should act as a foundation of improvements which should be continuously improved. In chapter 6 a summary of gaps has been presented which the Company can utilise for future research in order to continuously improve the product realisation process.

Two main areas within the production system that can be studied and improved in the future are capacity planning in the manufacturing unit and structuring the component inventory in the assembly function. Improvements in these areas will enable Company A to continue its journey to become Lean and gain greater control over the production processes as well as increasing the efficiency and flexibility.

In order to enable capacity planning in the manufacturing function data on process times for each fitting needs to be gathered. It is suggested to start the data collection and plan capacity for the folding process since this has been identified as the bottleneck by the authors. Not only will this increase the control, it will also enable

the Company to monitor and reduce WIP levels which will increase the flow and predictability of the production system.

It has been discussed that kitting cycle times are very time consuming since only a fraction of the components have standard storage locations. The picking list provided will only state pick locations for these components while the remaining components are picked from memory in an unpredictable nature. If Company A successfully implement the identification system proposed and further develop the WMS, the pickers will be provided with a pick list containing the needed information in order to reduce kitting cycle times significantly.

The product development department should focus on improving the Stage-Gate model and standardising work procedures firstly. Studying and improving these will enable the product development department to better handle customised orders and support them in becoming more efficient.

The Stage-Gate model needs to be adjusted for various project sizes or complemented with supporting tools in order to create a better flow in the development process and relieve the designers from using unstructured work procedures. Focusing on this in the future together with standardising work procedures will enable the designers to concentrate on the essentials in the design process and not on memorising various requirements and rules. Structuring work procedures is essential in order for the product development department to grow in line with the company, which would mean expanding the product assortment and the work force to meet demands. Improved standardised work procedures will help new employees to catch up on work procedures quicker and relieve experienced employees from some of the training.

### **8.3 The Authors Contribution to Lean studies**

The suggested improvements for Company A are obviously specific for this case. However, throughout the thesis it has been shown that a Lean study will visualise the shortcomings at a company and provide a path to continuously improve. Companies that find themselves in the same environment as Company A, where the customers demand a wide product range, standard products and customised products, should focus on increasing the efficiency and flexibility of the production system as well as utilising proven product design techniques in order to be competitive. Furthermore, every company has to find their own unique way to become Lean which should be supported by the foundation of the Lean philosophy. In this thesis proven Lean tools has been utilised and complimented with various tools on production and inventory control as well as various product design techniques in a successful way. There are no reasons to why this cannot be accomplished in other businesses as well.

### **8.4 Project Reflection**

The project started with a vague purpose of improving the production system when the authors arrived in Australia. The idea was to conduct a pre-study in order to establish a proper purpose that would suit both the company and the authors. This was also the case, and the idea of conducting a project with its roots in the Lean

philosophy was determined together with the company supervisor. The supervisor gave the authors the freedom to conduct the project however they wanted and provided weekly meetings to allow for feedback.

This freedom was considered to be a great challenge and a situation the authors enjoyed. The main challenge was to be confident enough to take decisions in order for the authors to complete the project within the time frame.

The methodology chosen for the project has been followed, mainly due to the nature and scope of the project. The theoretical review gave the authors an understanding and guidance on how a study on site could be conducted. When data was collected the authors often reflected on how to assure credibility, something that could have been forgotten if this insight had not been gained from the theoretical review. The methodology utilised in VSM established the idea of the structure on how to conduct the study, where a current state and future state was established. Due to the time frame of the project the last part 'executing the implementations' was left to the company.



## References

- Barcodesinc(electronic).  
<http://www.barcodesinc.com/symbol/ls2208.htm>, 2013-04-15
- Barcodescannersdiscount(electronic).  
<http://barcodescannersdiscount.com/ze44s.html>, 2013-04-15
- Bell, J. (2005). Doing your Research Project: A guide for first-time researchers in education, health and social science. McGraw-Hill Education, Berkshire, UK. 4<sup>th</sup> Edition
- Biazzo, S. (2009). Flexibility, Structuration, and Simultaneity in New Product Development, Journal of Product Innovation Management, Vol 26 Issue 3
- Blackenfelt, M. (2001). Managing complexity by product modularisation. Royal Institute of Technology, Stockholm, Sweden
- Blecker T., Abdelkafi N. (2007). The Development of a Component Commonality Metric for Mass Customization. IEEE Transactions on engineering management, Vol. 54, No. 1
- Boothroyd, G. (2005). Assembly Automation and Product Design. Taylor & Francis, Flordia, USA. 2<sup>nd</sup> Edition
- Boothroyd, G. Product Design for Manual Assembly. Marcel Dekker, Inc. New York, USA
- Boothroyd, G. Design for Modularity.
- Bryman, A. (2012). Social Research Method. Oxford University Press, New York, USA. 4<sup>th</sup> Edition
- Cooper, R.G. & Kleinschmidt, E.J. (2001). Stage-Gate process for new product success (electronically). Innovation Mangement U3, Bröndby, Denmark.  
<http://www.stage-gate.eu/download-articles.asp>, 2013-02-08
- Denscombe, M. (2003). The good research guide: for small-scale social research projects. McGraw-Hill Education, Philadelphia, PA, USA. 2<sup>nd</sup> Edition
- Fixson, S. K., (2007), Modularity and Commonality Research: Past Development and Future Opportunities, Sloan School of Management, Massachusetts Institute of Technology, Cambridge, MA 02138, USA

- Geeks(electronic).  
<http://www.geeks.com/products.asp?cat=SYS,2013-04-15>
- Hill, A. & Hill, T. (2011). Essential Operations Management. Palgrave Macmillan, Hampshire, United Kingdom
- Hopp, W.J. & Spearman, M.L. (2001). Factory Physics. McGraw-Hill Higher Education, New York, USA. 2<sup>nd</sup> Edition
- Hoyle, D. (2009). ISO 9000 Quality Systems Handbook. Elsevier Ltd, Great Britain. 6<sup>th</sup> Edition
- Höst, M., Regnell, B. & Runeson, P. (2006). Att genomföra examensarbete. Studentlitteratur AB, Lund, Sweden
- John, A., Neran, R., Roenpage, O. & Staudter, C. (2008). Six Sigma + Lean Toolset. UMS GmbH consulting, Frankfurt, Germany
- Liker, J.K. (2004). The Toyota Way: 14 Management Principles from the World's Greatest Manufacturer. McGraw-Hill, USA
- Manos, T (2006). Value Stream Mapping – an introduction. American Society for Quality  
<http://asq.org/quality-progress/2006/06/lean/value-stream-mapping--an-introduction.html> 2013-03-02
- Marklund, J., Head of department at Division of Production Management, Lund University, lecture March 2012
- May, T. (2011). Social Research. McGraw-Hill Education, New York, USA. 4<sup>th</sup> Edition
- Pahl, G., Beitz, W., Feldhusen, J., Grote, K.-H., (2007), Engineering Design – A Systematic Approach (3rd Edition), Springer-Verlag New York, LLC
- Richco-inc (electronic)  
<http://www.richco-inc.com/products/rivetsscrewswashersnuts/99-rivets-screws-washers-nuts-catalog.html?PartNum=&country=RICHCOUSA&grpcode=C1110>
- Rother, M., Shook, J. (1999). Learning to See. Lean Enterprise Institute, Massachusetts, USA
- Rother, M., Shook, J. (2009). Learning to See. Lean Enterprise Institute, Cambridge, USA
- Rowbotham, F., Galloway, L. & Azhashemi, M. (2007). Operations Management in Context. Elsevier Limited, Oxford, UK. 2<sup>nd</sup> Edition
- Rudberg, M., Wikner, J. (2004). Production Planning & Control – Mass customization in terms of the customer order decoupling point. Taylor & Francis Ltd, Vol. 15, No. 4

- Runeson, P. & Höst, M. (2008). Guidelines for conducting and reporting case study research in software engineering (electronically). *Empir Software Eng*, Vol 14
- Shingo, S. & Dillon, P.A. (1985). *A Revolution in Manufacturing: The SMED System*. Productivity Inc., Portland, USA
- Simpson, T., W., Maier, R.A., J. (2001). *Product Platform Design: Method and Application*. Springer, New York, USA
- Simpson, T., W., Siddique, Z., Jiao, Jianxin, (2005), *Product Platform and Product Family Design*, Springer, New York, USA
- Thevenot H. and Simpson T., (2007). *Journal of Engineering Design - A Comprehensive Metric for Evaluating Component Commonality in a Product Family*. Taylor & Francis, Vol. 18, No. 6
- Ulrich, K., (1993), *The Role of Product Architecture in the Manufacturing Firm*, Massachusetts Institute of Technology, Sloan School of Management, Room E53-390, Cambridge, MA 02139, USA
- Ulutas, B. (2011). *An application of SMED Methodology*. *World Academy of Science*, Vol 79
- Walliman, N. (2006). *Social Research Methods*. SAGE Publications L.td, London, UK
- Walton, M., (1999), *Strategies for Lean Product Development*, Lean Aerospace Initiative Center for Technology, Policy, and Industrial Development, Massachusetts Institute of Technology, 77 Massachusetts Avenue, Room 41-205 Cambridge, MA 02139
- Wikner, J., Rudberg, M. (2005). *International Journal of Operations & Production Management – Integrating production and engineering perspectives on the customer order decoupling point*. Emerald Group Publishing Limited, Vol. 25, No.7
- Womack, J. & Jones, D. (2003). *Lean thinking: Banish waste and create wealth in your corporation*. Simon & Schuster UK Ltd, London, United Kingdom
- Yang, K., El-Haik, B. (2003). *Design for Six Sigma*. McGraw-Hill Companies Inc, USA





## Appendix A: Delivery Discrepancy Form

### Delivery discrepancy form

<b>Date:</b>	<b>Delivery received by:</b>																																				
<b>Order no: PPO</b>	<b>Signature:</b>																																				
<p><b>Quality issue:</b></p> <p>Fill out the information below:</p> <table border="1" style="width: 100%; border-collapse: collapse;"> <tr><td style="width: 30%;">Line number:</td><td></td></tr> <tr><td>Type of material:</td><td></td></tr> <tr><td>Quantity:</td><td></td></tr> <tr><td>Dimension:</td><td></td></tr> <tr><td>Pack number:</td><td></td></tr> <tr><td>Description and Picture:</td><td></td></tr> </table>		Line number:		Type of material:		Quantity:		Dimension:		Pack number:		Description and Picture:																									
Line number:																																					
Type of material:																																					
Quantity:																																					
Dimension:																																					
Pack number:																																					
Description and Picture:																																					
<p>Information to be filled out by purchasing officer:</p> <table border="1" style="width: 100%; border-collapse: collapse;"> <thead> <tr> <th style="width: 60%;">Action</th> <th style="width: 15%;">Date</th> <th style="width: 25%;">Tick box</th> </tr> </thead> <tbody> <tr> <td>Email and picture sent to supplier</td> <td></td> <td></td> </tr> <tr> <td>Response recieved by supplier</td> <td></td> <td></td> </tr> <tr> <td colspan="3">Description:</td> </tr> <tr> <td colspan="3" style="height: 40px;"></td> </tr> <tr> <td>Course of action</td> <td></td> <td></td> </tr> <tr> <td colspan="3">Description:</td> </tr> <tr> <td colspan="3" style="height: 40px;"></td> </tr> <tr> <td>Discrepancy resolved</td> <td></td> <td></td> </tr> </tbody> </table>		Action	Date	Tick box	Email and picture sent to supplier			Response recieved by supplier			Description:						Course of action			Description:						Discrepancy resolved											
Action	Date	Tick box																																			
Email and picture sent to supplier																																					
Response recieved by supplier																																					
Description:																																					
Course of action																																					
Description:																																					
Discrepancy resolved																																					
<p><b>Non-conforming delivery: Input measured information</b></p> <table border="1" style="width: 100%; border-collapse: collapse;"> <thead> <tr> <th style="width: 10%;">Line</th> <th style="width: 40%;">Description</th> <th style="width: 30%;">Quantity Received</th> <th style="width: 20%;">Pack no</th> </tr> </thead> <tbody> <tr style="background-color: #e0e0e0;"> <td>E.G '002</td> <td>0.7 X 1219 X 2440 CR</td> <td>90 SH (63mm)</td> <td>B27230130C</td> </tr> <tr><td> </td><td> </td><td> </td><td> </td></tr> <tr><td> </td><td> </td><td> </td><td> </td></tr> <tr><td> </td><td> </td><td> </td><td> </td></tr> <tr><td> </td><td> </td><td> </td><td> </td></tr> <tr><td> </td><td> </td><td> </td><td> </td></tr> <tr><td> </td><td> </td><td> </td><td> </td></tr> <tr><td> </td><td> </td><td> </td><td> </td></tr> </tbody> </table>		Line	Description	Quantity Received	Pack no	E.G '002	0.7 X 1219 X 2440 CR	90 SH (63mm)	B27230130C																												
Line	Description	Quantity Received	Pack no																																		
E.G '002	0.7 X 1219 X 2440 CR	90 SH (63mm)	B27230130C																																		
<p>Provide this document to Harry, the purchasing officer.</p>																																					

## Appendix B: Detailed Inspection Documentation

### Inspection of incoming raw material

---

1. When a pallet of raw material has been opened, assure that no defects can be identified.
- Inspect the goods and ensure that the most common issues described below have not been identified:
1. No obvious damages on edges or in general from e.g. hard impacts during transportation.
  2. Wavy metal sheets, as visualised in the figures below.
  3. If secondary judgment is needed contact Harry, the purchasing officer.
  4. If defects have been identified, employee should fill out the **Delivery discrepancy form**.

In the case when the top part of sheets are wavy, only that specific quantity is considered defect.



---

In the case when the top and bottom part of sheets are wavy, the quantity of the whole pallet is considered defect.



2. If no defects have been identified the following should be inspected for all goods received, assuring that inspection conforms with the information on the **delivery docket**:
1. **Dimension conformance:** Measure the thickness of one sheet with a calliper. Accept tolerances of  $\pm 0,1\text{mm}$ .
  2. **Quantity conformance:** Measure the height of the stack of sheets with a calliper to identify that the correct quantities have been received. For example: qty of sheets \* measured thickness = measured height. Only report discrepancies that are greater than 20mm.
  3. **Material conformance:** Assure that correct material type have been received.
  4. If any discrepancies have been identified, employee should fill out the **Delivery discrepancy form**.

## Appendix C: Supplier Evaluation Tool

Steel AB	Nbr of rejected orders	Total nbr of orders	Nbr of rejected lines	Total nbr of lines	Nbr of credit notes	Nbr of quality claims	Total quantities ordered	Total Quantities of Quality claims
January	0	5	0	5	0	0	100	0
February	0	2	0	2	0	0	100	0
March								
April								
May								
June								
July								
August								
September								
October								
November								
December								
SUM	0	7	0	7	0	0	200	0

						Supplier Rating		
Supplier	KPI Rejected Orders %	KPI Rejected Lines %	KPI Rejected Goods %	Nbr Credit Notes	Nbr quality claims of	Goods Reliability	Order Line Reliability	Order Reliability
<b>Steel AB</b>	0,0%	0,0%	0,0%	0	0	A	A	A
<b>Steel Corp.</b>	25,0%	16,7%	5,0%	0	1	D	D	D

Supplier Goals			
KPI Rejected Orders %	KPI Rejected Lines %	KPI Rejected Goods %	Supplier Rating
<b>1,0%</b>	2,5%	1,0%	A
<b>2,5%</b>	5,0%	2,0%	B
<b>5,0%</b>	7,5%	3,0%	C
<b>7,5%</b>	10,0%	4,0%	D

## Appendix D: 5S

5S Team member				5S Officer	
Date:		Tagged by:		<b>Action to take</b>	
Item Description:				Trash	
Area:				Move to area	
<b>Item type</b>				Store	
Raw materials	<input type="checkbox"/>	Tool	<input type="checkbox"/>	Other	
WIP	<input type="checkbox"/>	Jigs	<input type="checkbox"/>	Other:	
Machine Parts	<input type="checkbox"/>	Consumables	<input type="checkbox"/>	Date:	
Other:				Supervisor/Managers initial:	
<b>Reason tagged</b>				Tag number:	
Not Required	<input type="checkbox"/>	Unknown owner	<input type="checkbox"/>	Additional Comments:	
Defect	<input type="checkbox"/>	Obsolete	<input type="checkbox"/>		
Scrap	<input type="checkbox"/>	Other:	<input type="checkbox"/>		
Other:					

### Red tag documentation

Tag number	Item description	Area	Action taken





## Appendix E: 5S Audit Form

Audit results January							
Scoring scale							
Worst case = 0		Not acceptable = 1		Acceptable = 2	High class = 3	World Class = 4	
					Team Blue	Team Green	
<b>1S</b>	Audit item	Description	Score	Score			
<b>Sort</b>	1	Are there any unnecessary WIP or load carriers around?	0	1			
	2	Is there any scrap around?	0	1			
	3	Are there unnecessary tools, jigs or consumables around?	0	1			
	4	Can any old information be identified e.g. old production orders?	1	3			
	5	Have unnecessary tools, jigs and consumables been red tagged?	1	1			
Additional comments:					Category total:	2	7
<b>2S</b>	Audit item	Description	Score	Score			
<b>Straighten</b>	6	Are storage locations labeled with correct descriptions?	2	4			
	7	Does tools, jigs and consumables have permanent locations?	3	3			
	8	Used tools, jigs and consumables are put back to its location?	2	4			
	9	Are WIP stacked correctly onto pallets?	3	3			
	10	Are load carriers placed correctly?	2	4			
Additional comments:					Category total:	12	18
<b>3S</b>	Audit item	Description	Score	Score			
<b>Shine</b>	11	Are floors free of waste, water and oil?	2	4			
	12	Are machines well maintained?	3	3			
	13	Is the work area clean?	2	4			
	14	Are tools clean and well maintained?	3	3			
	15	Does the area have sufficient cleaning utensils and bins?	2	4			
Additional comments:					Category total:	12	18
<b>4S</b>	Audit item	Description	Score	Score			
<b>Standardise</b>	16	Are improvement ideas generated?	2	4			
	17	Are the standard work procedures clear and visual?	3	3			
	18	Are the first three S' maintained?	2	4			
	19	Are designated and hazardous areas clearly marked?	3	3			
	20	Is the Red Tag area maintained, documented and organised?	2	4			
Additional comments:					Category total:	12	18
<b>5S</b>	Audit item	Description	Score	Score			
<b>Sustain</b>	21	Are employees adequately educated on the 5S system?	2	4			
	22	Are standard procedures up to date?	3	3			
	23	Are activity boards up to date?	2	4			
	24	Have improvements been implemented?	3	3			
	25	Are audits and 5S activities conducted according to plan?	2	4			
Additional comments:					Category total:	12	18











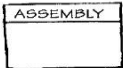

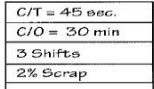

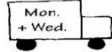







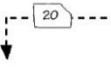
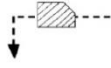

## Appendix F: 5S Activity Board

5S	Continuous improvements		Score and Reward	KPIs
	Ideas	Ongoing implementations Before/After photographs		
Room for established work procedures for the MS End of shift routine			Team Blue	Scrap rates
			Team Green	Safety
Red tag forms	Idea forms			5S poster



## Appendix G: Icon List VSM

Material Icons	Represents	Notes
	Manufacturing Process	One process box equals an area of flow. All processes should be labeled. Also used for departments, such as Production Control.
	Outside Sources	Used to show customers, suppliers, and outside manufacturing processes.
	Data Box	Used to record information concerning a manufacturing process, department, customer, etc.
	Inventory	Count and time should be noted.
	Truck Shipment	Note frequency of shipments.
	Movement of production material by <u>PUSH</u>	Material that is produced and moved forward before the next process needs it; usually based on a schedule.
	Movement of finished goods to the customer	
	Supermarket	A controlled inventory of parts that is used to schedule production at an upstream process.
	Withdrawal	Pull of materials, usually from a supermarket.
	Transfer of controlled quantities of material between processes in a "First-In-First-Out" sequence.	Indicates a device to limit quantity and ensure FIFO flow of material between processes. Maximum quantity should be indicated.

Information Icons	Represents	Notes
	Manual Information Flow	For example: production schedule or shipping schedule
	Electronic Information flow	For example via electronic data interchange.
	Information	Describes an information flow.
	Production Kanban (dotted line indicates kanban flow)	The "one-per-container" kanban. Card or device that tells a process how many of what can be produced and gives permission to do so.
	Withdrawal Kanban	Card or device that instructs the material handler to get and transfer parts (i.e. from a supermarket to the consuming process).
	Signal Kanban	The "one-per-batch" kanban. Signals when a reorder point is reached and another batch needs to be produced. Used where supplying process must produce in batches because changeovers are required.
	Sequence-Pull Ball	Gives instructions to immediately produce a predetermined type and quantity, typically one unit. A pull system for subassembly processes without using a supermarket.
	Kanban Post	Place where kanban are collected and held for conveyance.
	Kanban Arriving in Batches	
	Load Leveling	Tool to intercept batches of kanban and level the volume and mix of them over a period of time.
	"Go See" Production Scheduling	Adjusting schedules based on checking inventory levels.
<b>General Icons</b>	<b>Represents</b>	<b>Notes</b>
	"Kaizen Lightning Burst"	Highlights improvement needs at specific processes that are critical to achieving the value stream vision. Can be used to plan kaizen workshops.
	Buffer or Safety Stock	"Buffer" or "Safety Stock" must be noted.
	Operator	Represents a person viewed from above.

208

## Appendix H: VSM 1

The first value stream mapping of the current state was conducted to identify opportunities of improvement within the production system for a specific flow. The purpose was to follow a fitting that will represent the flow for a specific process family, as described in chapter 3.5.6. The chosen fitting is considered a high volume product which is one of the reasons why it was chosen, the other reason was that it flows through all process steps in production, thus enabling all processes to be evaluated. Listed in table H.1 is the representative process family.

**Table H.1** Product A's representative process family

	Process steps						
	Punching	Rolling	Folding	Sub-assembly	Welding	Painting	Assembly
Product A	X	X	X	X	X	X	X

Five orders for the same type of job were followed because they were batched as one to reduce setup time. Illustrated in the VSM in figure H.1 is the flow of one fitting for the total batch of 51 followed, this to visualise the waiting times and queue times of one-piece flow. Simplification had to be done due to feasibility reasons; this was that only the main part of the body was considered throughout the VSM.

In order for the VSM-process to be manageable and done in a reasonable time, the authors have made several assumptions along its course. The assumptions made are as follows:

- **Daily Deliveries:** Means that daily are not necessarily made every day to and from the company, rather that the deliveries can be done on any given day of the week.
- **Cycle and Process Time of the Puncher:** These were estimated based on the total process and cycle time, which was divided by the number of parts being punched on the sheet. The process time in this operation includes the time the machine is operating plus the time it takes the operator to separate the parts from the metal sheet.

- **Cycle and Process Time of the Folder:** Since the authors were not present during this process, these times had to be assumed. An estimated time of around 50 minutes was given to the authors for 50 parts to be folded. An assumed process time of between 4-5 seconds was based on one fold per second. The estimated time of 50 minutes, minus 5 minutes setup was divided by 50, which gave the cycle time for one part.
- **Process Time of the Painting:** This is the sum of all the operations included in the paint operation: Washing, Drying, Painting, and Heating

Definitions:

- **2 (1) days:** The parenthesis number means the number of days the product has been waiting when the factory has been operational, while the number before states the actual amount of days the product has been waiting.
- **Time:** Is defined as all days available of the full year.

Observations and measurements were done by both authors to secure credibility:

- The whole process starts by printing out a hardcopy with information about the job. The hardcopy includes important information such as drawings for punching, drawing instructions for folding, material consumption and quantities. This hardcopy is stacked together with others by the puncher, in the specific order they are intended to start. However, this is not deterministic, and could be changed by the supervisor at any time if needed.

For the specified job followed, the hardcopy information was left by the punching process throughout the flow in the metal shop. This, since it obtained punching information for a separate part, the gear tray for the fitting, a part that was punched many days after the main part.

- Punching is done by a CNC machine that is manned by one operator. However, both internal and external setup is solely done by the supervisor not the operator as well as the decision to start the job. This specific setup included tooling change, disposing of scrap, pallet change and loading the CNC program. In addition to this, set-up could also include change of raw material.

During a punching cycle time the operator shakes the pervious punched metal sheet to separate the punched parts from the scrap, and then stacks the parts on a pallet next to the puncher. This is a process that is always needed, independent of what fitting is punched. However, depending on the fitting punched there will be a period of time when the operator has nothing to do.



When the whole batch was completed, the pallet with the punched parts was moved to a location near the next process, the rolling machine.

- The rolling machine has to be setup manually due to out-dated design. Setup time was both internal and external including tooling change, re-adjustments, trial runs and placing the WIP in an ergonomic way. The trial runs decreased the first yield pass percentage; this can be seen in figure H.1. However, when the process was up and running no more issues occurred. When rolling was completed the pallet was placed near the folding operation area.
- The folding machine is CNC programmed and manned by one operator. Setup includes tooling change, loading CNC program, trial run, re-adjustments of CNC program and locating the WIP for the job. For the specific job followed, setup only included loading CNC program and locating the WIP for the job. The folding function is very congested with a lot of WIP waiting to be processed.
- At this point the job was close to its due date and got rushed, which meant that sub-assembly started its process when folding had completed 50 percent of the batch. When sub-assembly had completed a few fittings of the batch the welding process began. This phenomenon turned into three stations with small amounts of WIP between them. However, since one fitting was followed there was still waiting time between the processes, this since the phenomena appeared half-way through the batch.
- The whole batch waits for the painting process since there is a lot of WIP inventory for this process. The paint line is closed down once a week in order to save energy and due to excess capacity. The paint line is manned by three operators, two who load and offload the line, and one who operates the painting chamber, manually adding paint if quality is not good enough. It is a one pace flow line consisting of four processes: washing, drying, painting, and heating.

When the process is completed the batch is moved to a designated picking area. However, if the picking area is too congested, the batch will sit and wait in the painting area until the assembly function decides to start the assembly of the job.

- Before final assembly, the remaining components are picked by one of two pickers. Components picked for this job was ballasts, extruded side bars, wires and lamp holders. These components are sourced.

When all items for the whole job have been picked it is either placed at an assembly line or in the picking area, waiting for an assembly line to be available. In this case it was waiting at the picking area.

The fitting was assembled in a line consisting of three operators forming three stations. There is no set takt for the operations, but station times are fairly levelled based on assumptions from experience. However, if the line gets congested, operators help each other and try to achieve a good flow through the process.

- Batch is placed at the finished goods inventory and was shipped the day after.

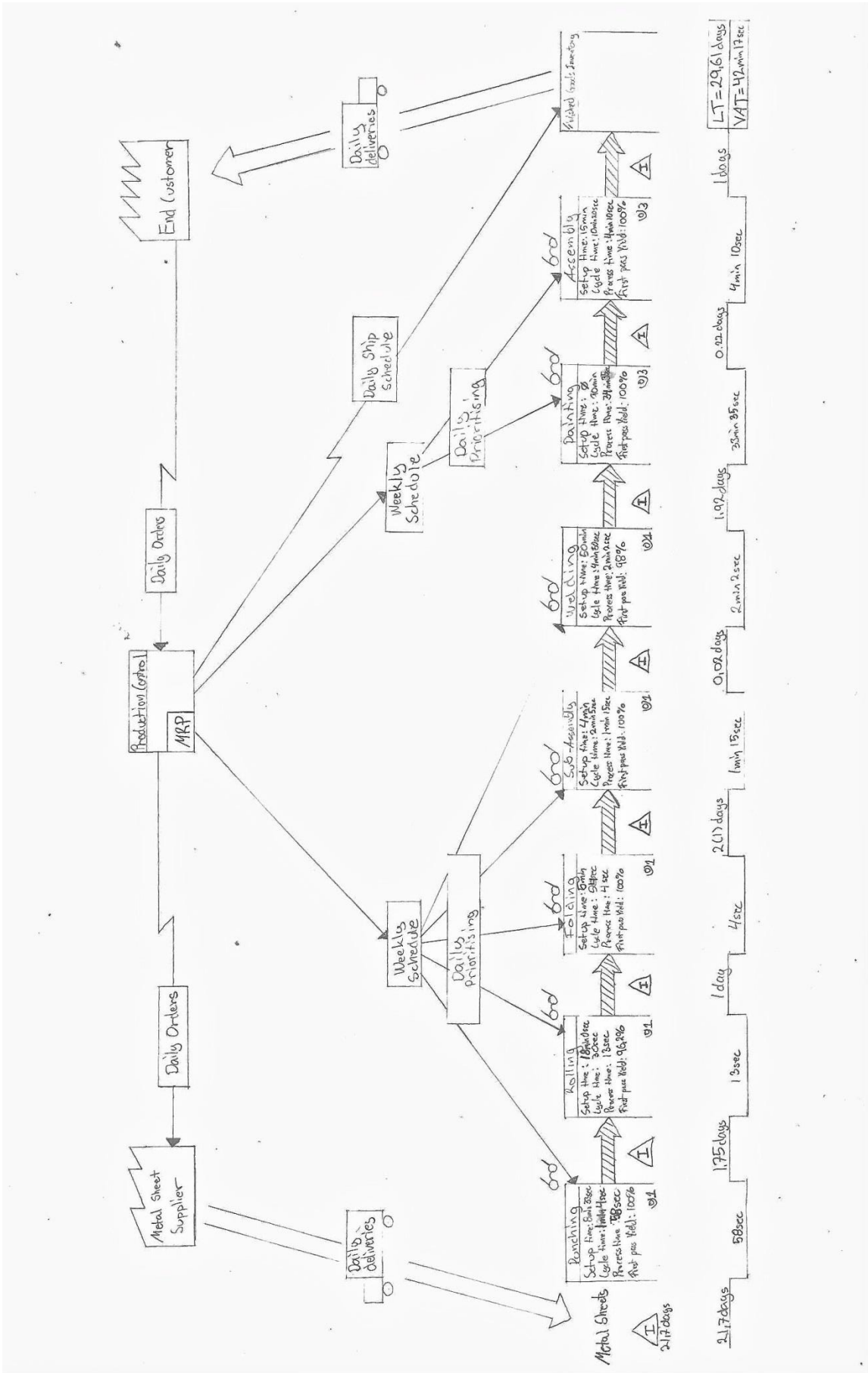

Figure H.1 Value stream map made by the authors



## Appendix I: VSM 2

The second value stream mapping of the current state was conducted to identify opportunities of improvement within the production system for a flow for one product with two main parts, a frame and a body. The purpose was to follow a fitting that will represent the flow for a specific process family, as described in chapter 3.5.6 as well as study how the two flows for the same product interact. The observed fitting is considered a high volume product which is one of the reasons why it was chosen, the other reason was that it is one of the more complex fittings to manufacture and assemble since it has high requirements on tightness to prevent contamination of clean environments. The representative process family can be viewed in table I.1.

**Table I.1** Product A's representative process family

	Process steps							
	Punching	Folding	Welding 1	Welding 2	Painting	Sub-assembly	Sub-assembly	Final Assembly
Product B - Body	X	X	X	X	X	X	X	X
Product B - Frame	X	X	X		X		X	X

Two orders for the same type of job were followed because they were batched as one to reduce setup times. Illustrated in the VSM in figure I.1 is the one-piece flow for the two main parts of the fitting for the total batch of 45 followed, this to visualise the waiting times and queue times of a one-piece flow.

In order for the VSM-process to be manageable and done in a reasonable time, the authors have made several assumptions along its course. The assumptions made are as follows:

- **Daily Deliveries:** Means that daily are not necessarily made every day to and from the company, rather that the deliveries can be done on any given day of the week.
- **Cycle and Process Time of the Puncher:** These were estimated based on the total process and cycle time, which was divided by the number of parts being punched on the sheet. The process time in this operation includes the time the

machine is operating plus the time it takes the operator to separate the parts from the metal sheet.

- **Setup time of the Folder:** Since the authors were not present during the setup of the machine for this batch, a setup for the same tooling but for another fitting has been measured and is considered to be representative for this situation as well.
- **Process Time of the Painting:** This is the sum of all the operations included in the paint operation: Washing, Drying, Painting, and Heating

Definitions:

- **Time:** Is defined as all days available of the full year.

Observations and measurements were done by both authors to secure credibility. Since the general aspects of the processes have been covered in the description of Appendix H, this description will only cover aspects that differ and are of interest for this VSM.

- This VSM visualised the insufficient quality assurance for incoming raw material. When all the parts for the body had been punched and the process was completed there was a changeover in order for the frames to be punched. During the processing of the batch, metal sheets had to be replenished. Quality issues were identified with the metals sheets when the new pallet was opened at the operating bench beside the puncher. Since no more material was available the operation had to be cancelled and delayed until next shipment. This issue induced 30 minutes to handle the problem, incorporating purchasing personnel as well.
- Yield loss was identified at the folding process for the value stream, visualised in figure I.1. This was the case for both parts, which were separately setup and processed. First pass yield is lower for the frames since it was setup twice. It was setup twice because the parts that had been punched prior to the quality issues were processed before the remaining parts had been completed at the punching operation. This meant that the folder had to be setup again when the remaining parts were completed hence inducing trail runs again. A yield loss at the folder is most likely to produce scrap since it is hard to rework a wrongly folded part. A high amount of WIP waiting to be processed was again observed at the folding function.

Yield loss was also identified at the painting process. The bodies were hung too high on the line which resulted in fragments not being painted. However, the affected fittings were reworked manually and could be used by

downstream processes.

- The high requirements on tightness induce an extensive assembly operation, where cavities have to be sealed with silicon and foam strips. These operations were conducted as sub-assemblies manned by one operator. When the sub-assemblies were completed, all parts were brought together for the final assembly.
- Earlier overproduced parts were identified and obtained to cover the yield loss from the folding process. In addition to this, there was also a lack of communication between the supervisors in the paint shop and assembly. The earlier mentioned reworked bodies were left at the paint shop, and the supervisor in the assembly was not notified. This caused confusion at the assembly line when they realised that some bodies were missing and the order could not be completed. Time was spent trying to find similar bodies in semi-finished goods inventory, since there is a lack of structure in holding this inventory this is a time consuming task. Some bodies were found but they needed rework in order to meet the requirements for the job. Finally, before any work was initiated, the reworked bodies that had been left in the paint shop were found, but a lot of time had been wasted.
- The quality issue for the frames at the punching process affected the flow. The punched bodies had to wait until the raw material was delivered for the frames, which took about three days. Other than that and the fact that the folder was setup twice, the interaction of the flows between the body and frame were good and processes did not start until necessary.

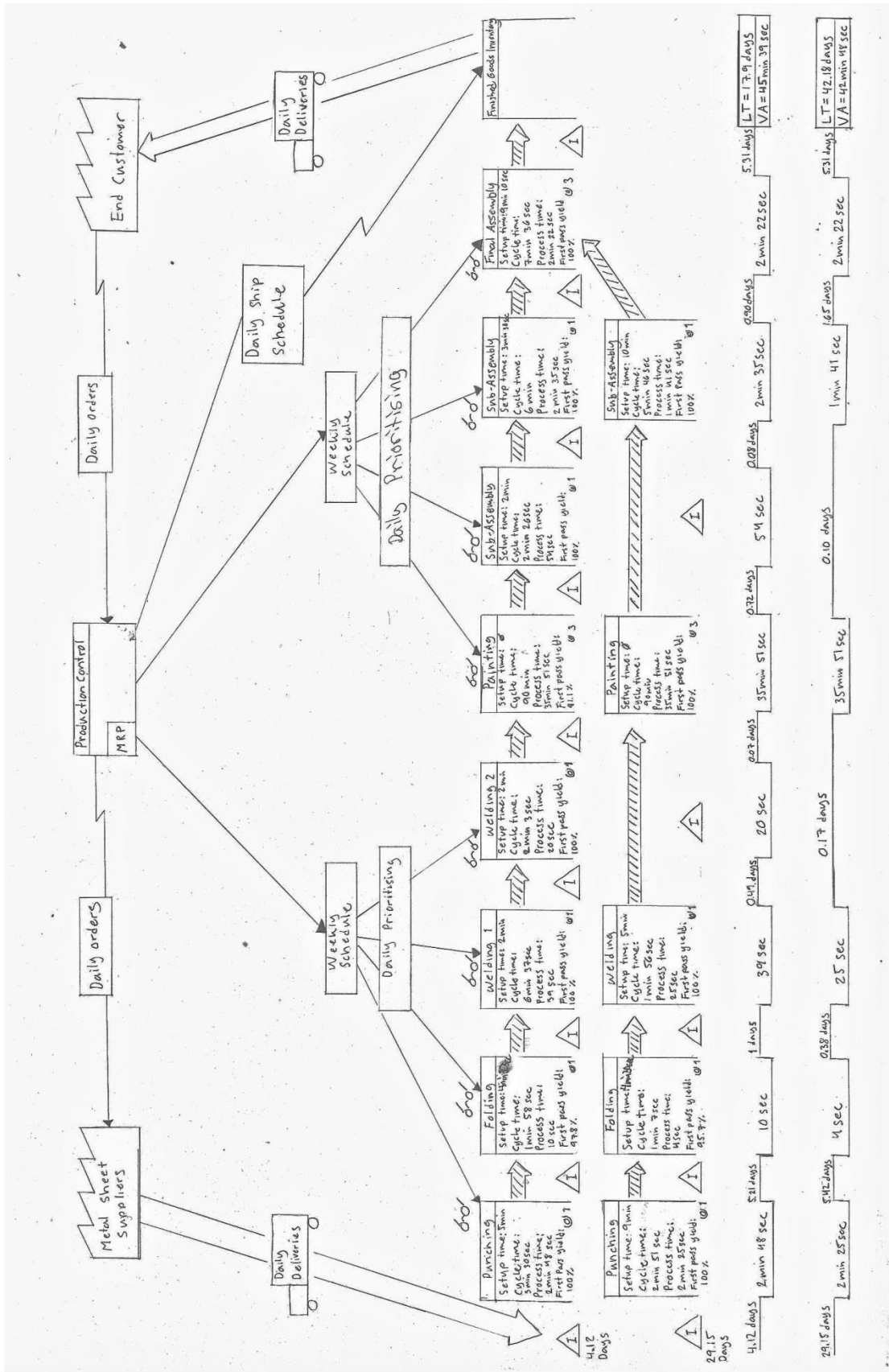

Figure I.1 Value stream map made by the authors



## Appendix J: EOQ Calculations Data

Fitting	Minimum internal orders	Maximum internal orders	Avg. batch size (max)	Avg. batch size (min)	Optimal internal orders = $D/Q^*$	$Q^*$ = batch size	h= holding cost (\$)	A=ordering cost (\$)	D= demand (produced)
<b>A</b>	41	110	167	62	31	219	6	21	6829
<b>B</b>	23	48	236	113	26	208	6	24	5430
<b>C</b>	28	47	48	29	8	160	6	57	1343
<b>D</b>	12	19	80	50	7	144	6	65	957
<b>E</b>	22	31	52	37	7	157	6	65	1137
<b>F</b>	27	46	34	20	9	102	6	34	926
<b>G</b>	30	59	31	16	7	133	6	57	933
<b>H</b>	25	47	33	17	7	124	6	57	815
<b>SUM</b>	<b>208</b>	<b>407</b>			<b>102</b>	<b>1248</b>			<b>18370</b>

## Appendix K: Sensitivity Analysis of Various Holding Costs

Fitting	Minimum Savings			Maximum Savings		
$h = i \cdot c$	$h=20 \cdot 0,2$	$h=30 \cdot 0,2$	$h=40 \cdot 0,2$	$h=20 \cdot 0,2$	$h=30 \cdot 0,2$	$h=40 \cdot 0,2$
<b>A</b>	-210	-451	-654	1239	998	795
<b>B</b>	-469	-699	-892	131	-99	-292
<b>C</b>	813	638	489	1896	1721	1572
<b>D</b>	75	-84	-218	530	371	237
<b>E</b>	661	488	343	1246	1073	928
<b>F</b>	416	303	208	1062	949	854
<b>G</b>	1058	911	788	2711	2564	2441
<b>H</b>	815	678	563	2069	1932	1817
<b>SUM</b>	<b>3159</b>	<b>1785</b>	<b>627</b>	<b>10884</b>	<b>9510</b>	<b>8352</b>

## Appendix L: EOQ Data.

**Table L.1** Numbers under each process corresponds to number of setups for that fitting and process

Item Number	Fitting	Puncher	Form Roller	Folder	Sub-ASSY	Spot Welder
<b>AA</b>	A	1	0	2	0	1
<b>BB</b>	B	1	0	2	0	2
<b>CC</b>	C	2	1	3	1	1
<b>DD</b>	D	3	1	3	1	1
<b>EE</b>	E	3	1	3	1	1
<b>FF</b>	F	1	0	4	0	1
<b>GG</b>	G	2	1	3	1	1
<b>HH</b>	H	2	1	3	1	1

**Table L.2** Setup times for the processes in manufacturing and important costs

Hourly cost manufacturing (\$)	Material cost per metal sheet (\$)
60	20
Setups	Minutes
Complete Punch	8
Partial Punch	3
Folder	5
Form Roller	20
Spot Welder	3
Sub-ASSY	3

## Appendix M: Time Plan of the Project

The before and after time plans are visualised in figure M.1 and M.2. The authors believe that the time plan that was set up prior to the project was in general quite accurate compared to the actual time plan. However, the authors misjudged the literature review and data collection part. The authors learnt that additional literature and data is more than often aspects one need to get back to when conducting an analysis, especially in a case study environment. It is hard to predict and gather all information and data one need to conduct a thorough analysis and more than likely new questions arise that need to be answered, hence the need to further literature review and data collection.

The other parts of the project where tightly followed in order to successfully complete the project within the time frame of 20 weeks. However, since these time plans use the time scale of weeks, it does not reflect the variance in utilised hours per week. If the time plan had been established for hours per week, the two time plans would have deviated more. However, the changes in the time plans have not changed the expected results in the end. The authors established early on that implementation would not fit the time frame. All other expected results and outcomes have been achieved.

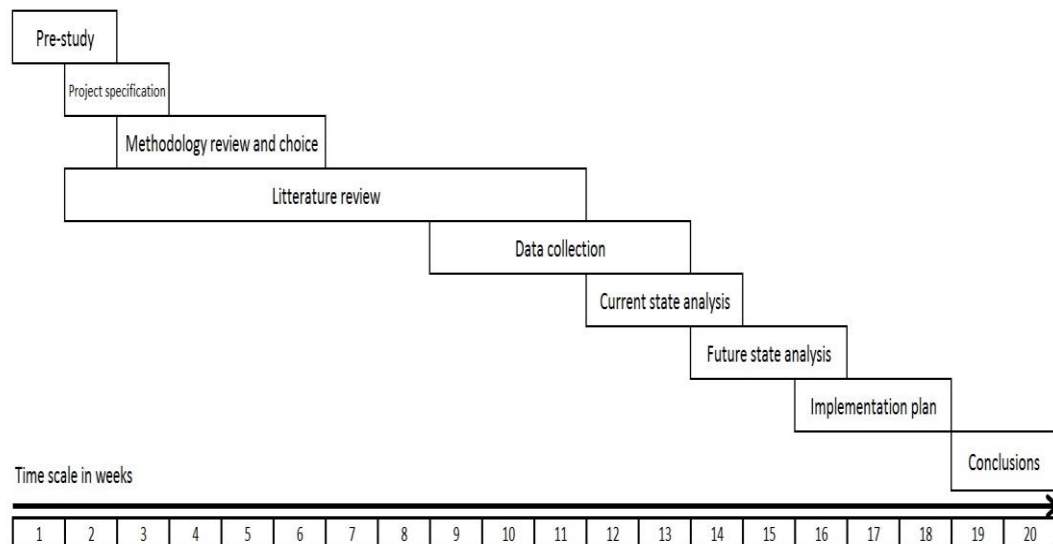

**Figure M.1** The established time plan before the project start

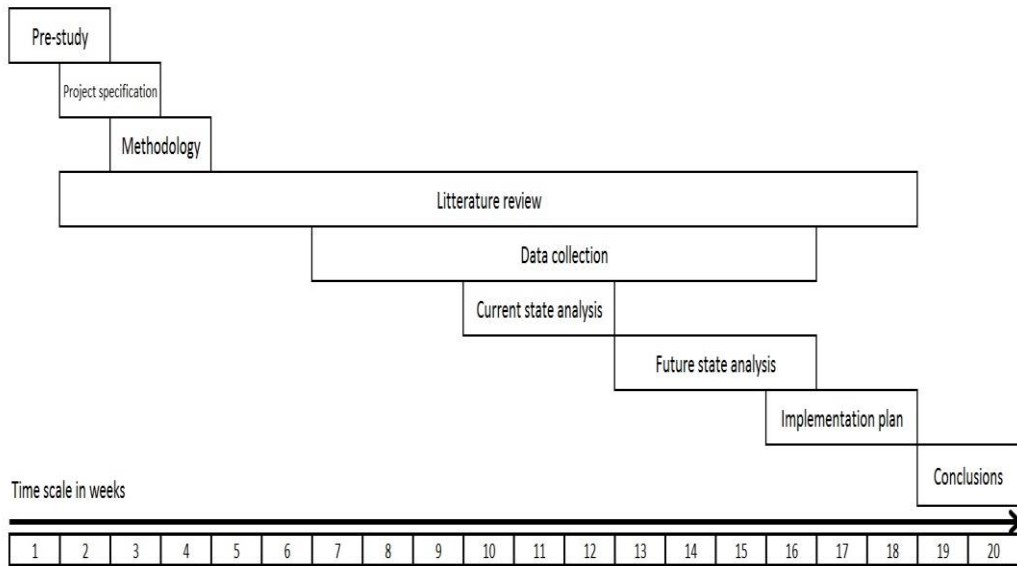

**Figure M.2** The adjusted time plan according to actual project execution

The work distribution of the project is visualised in table M.1. Only the chapters that have been specific work for the authors is visualised in the table, and the chapters left out from the table has been mutual work.

**Table M.1** Work distribution of the thesis

Lucas	3.2, 5.1, 7.1, 7.2, 7.3 and 7.4
Erik	3.3, 5.2, 7.5, 7.6

## Appendix N: DFMA Worksheet

Table N.1 DFMA Worksheet

part number	Nbr repeats	handling code	handling time (sec)	insertion code	insertion time (sec)	total assembly time (sec)	manual assembly cost (\$)	min number of parts	Remarks	material costs (\$)
1 Silicon	4			99	12	48	0,528		apply in corners all around frame	0,4
2 Diffuser acry clr 2 mm	1	85	5	00	1,5	6,5	0,0715	1	remove protection tape then place in fram	5,75
3 Diffuser K19	1	90	2	00	1,5	3,5	0,0385	1	place in frame	10,41
4 Frame strip Long	2	30	1,95	00	1,5	6,9	0,0759		place in frame	6
5 Frame strip Short	2	30	1,95	00	1,5	6,9	0,0759		place in frame	4
6 Reorientation	1			98	9	9	0,099		reorient frame when fastening strips	0
7 Frame strip Rivets	12	15	2,25	36	8	123	1,353		fasten with air pistol	0,6
8 Gal torsion springs 1.8 mm	4	23	2,36	32	4	25,44	0,27984		place in hook and bend with tweezers	1,96
9 Reorientation	1			98	9	9	0,099		move frame to next assembly station	0
10 Body	1	95	4	00	1,5	5,5	0,0605	1	place on workbench	20
11 Toggle rec arm plug	6	11	1,8	30	2	22,8	0,2508		fasten with power tool	0,3
12 Toggle rec arm washer	6	01	1,43	00	1,5	17,58	0,19338		place into bolt	0,6
13 Toggle rec arm bolt	6	10	1,5	38	6	45	0,495		place into bracket and screw to arm	0,6
14 Toggle rec arm	6	30	1,95	00	1,5	20,7	0,2277	6	placed in bracket	6
15	6	01	1,43	38	6	44,58	0,49038		nut	0,3

Toggle rec arm nut									fastened to bolt	
16 Reorient ation	1			98	9	9	0,099		reorient body	
17 Silicon	4			99	12	48	0,528		apply in and along corners of body	0,1
18 Gasket tape	4			99	12	48	0,528		Apply gasket tape	12
19 Terminal block	1	30	1,95	30	2	3,95	0,04345	1	place in frame and snap fasten	0,33
20 Terminal block screw	1	11	1,8	38	6	7,8	0,0858		place in terminal block and screw fasten	0,1
21 Ballast	1	30	1,95	00	1,5	3,45	0,03795	1	place on gear tray	6,31
22 Ballast bolts	2	11	1,8	38	6	15,6	0,1716		place and screw fasten	0,2
23 Reorient ation	1			98	9	9	0,099		turn gear tray over	0
24 Ballast nuts	2	01	1,43	38	6	14,86	0,16346		place and screw fasten	0,2
25 Reorient ation	1			98	9	9	0,099		turn gear tray over	0
26 Wires	7	91	3	38	6	63	0,693	7	place and screw fasten	0,7
27 Lamp holder	4	30	1,95	00	1,5	13,8	0,1518	4	place and snap fasten	0,72
28 Cable gland	1	10	1,5	48	8,5	10	0,11	1	place and screw fasten	1,5
29 Reorient ation	1			98	9	9	0,099		Place gear tray in body	0
30 Flex and plug	1	83	5,6	38	6	11,6	0,1276	1	place and screw fasten	1,55
31 Gear tray	1	91	3	00	1,5	4,5	0,0495		place in body	17,8
32 Gear tray screws	2	11	1,8	38	6	15,6	0,1716		place and screw fasten	0,2
33 Lamps	2	10	1,5	30	2	7	0,077	2	place and twist fasten	5
34 Frame	1	91	3	53	9	12	0,132	1	place and torsion fasten	15
<b>SUM</b>	<b>97</b>					<b>709,56</b>	<b>7,805</b>	<b>27</b>		<b>118,63</b>



## **Appendix O: Classification System Calculation Sheets**

MANUAL HANDLING—ESTIMATED TIMES (seconds)

Key:

ONE HAND

		Parts are easy to grasp and manipulate					Parts present handling difficulties (1)					
		Thickness >2 mm			Thickness ≤2 mm		Thickness >2 mm			Thickness ≤2 mm		
		Size >15 mm	6 mm ≤ size ≤15 mm	Size <6 mm	Size >6 mm	Size ≤6 mm	Size >15 mm	6 mm ≤ size ≤15 mm	Size <6 mm	Size >6 mm	Size ≤6 mm	
Parts can be grasped and manipulated by one hand without the aid of grasping tools		0	1.13	1.43	1.88	1.69	2.18	1.84	2.17	2.65	2.45	2.98
$(\alpha + \beta) < 360^\circ$		1	1.5	1.8	2.25	2.06	2.55	2.25	2.57	3.06	3	3.38
$360^\circ \leq (\alpha + \beta) < 540^\circ$		2	1.8	2.1	2.55	2.36	2.85	2.57	2.9	3.38	3.18	3.7
$540^\circ \leq (\alpha + \beta) < 720^\circ$		3	1.95	2.25	2.7	2.51	3	2.73	3.06	3.55	3.34	4
$(\alpha + \beta) = 720^\circ$												

ONE HAND with GRASPING AIDS

		Parts need tweezers for grasping and manipulation								Parts need standard tools other than tweezers	Parts need special tools for grasping and manipulation	
		Parts can be manipulated without optical magnification				Parts require optical magnification for manipulation						
		Parts are easy to grasp and manipulate		Parts present handling difficulties (1)		Parts are easy to grasp and manipulate		Parts present handling difficulties (1)				
Parts can be grasped and manipulated by one hand but only with the use of grasping tools		Thickness >0.25 mm	Thickness ≤0.25 mm	Thickness >0.25 mm	Thickness ≤0.25 mm	Thickness >0.25 mm	Thickness ≤0.25 mm	Thickness >0.25 mm	Thickness ≤0.25 mm	8	9	
$\alpha \leq 180^\circ$		0	1	2	3	4	5	6	7	8	9	
$0 \leq \beta \leq 180^\circ$		4	3.6	6.85	4.35	7.6	5.6	8.35	6.35	8.6	7	7
$\beta = 360^\circ$		5	4	7.25	4.75	8	6	8.75	6.75	9	8	8
$\alpha \leq \beta \leq 180^\circ$		6	4.8	8.05	5.55	8.8	6.8	9.55	7.55	9.8	8	9
$\beta = 360^\circ$		7	5.1	8.35	5.85	9.1	7.1	9.55	7.85	10.1	9	10

TWO HANDS for MANIPULATION

		Parts present no additional handling difficulties					Parts present additional handling difficulties (e.g. sticky, delicate, slippery, etc.) (1)				
		$\alpha \leq 180^\circ$			$\alpha = 360^\circ$		$\alpha \leq 180^\circ$			$\alpha = 360^\circ$	
		Size >15 mm	6 mm ≤ size ≤15 mm	Size <6 mm	Size >6 mm	Size ≤6 mm	Size >15 mm	6 mm ≤ size ≤15 mm	Size <6 mm	Size >6 mm	Size ≤6 mm
Parts severely nest or tangle or are flexible but can be grasped and lifted by one hand (with the use of grasping tools if necessary) (2)		0	1	2	3	4	5	6	7	8	9
8		4.1	4.5	5.1	5.6	6.75	5	5.25	5.85	6.35	7

TWO HANDS or assistance required for LARGE SIZE

		Parts can be handled by one person without mechanical assistance									
		Parts do not severely nest or tangle and are not flexible								Parts severely nest or tangle or are flexible (2)	Two persons or mechanical assistance required for parts manipulation
		Part weight <10 lb				Parts are heavy (>10 lb)					
Two hands, two persons or mechanical assistance required for grasping and transporting parts		Parts are easy to grasp and manipulate		Parts present other handling difficulties (1)		Parts are easy to grasp and manipulate		Parts present other handling difficulties (1)			
$\alpha \leq 180^\circ$		$\alpha \leq 180^\circ$	$\alpha = 360^\circ$	$\alpha \leq 180^\circ$	$\alpha = 360^\circ$	$\alpha \leq 180^\circ$	$\alpha = 360^\circ$	$\alpha \leq 180^\circ$	$\alpha = 360^\circ$	0	1
$\alpha \leq 180^\circ$		0	1	2	3	4	5	6	7	8	9
$\alpha = 360^\circ$		2	3	2	3	3	4	4	5	7	9

MANUAL INSERTION-ESTIMATED TIMES (seconds)

		Alter assembly no holding down required to maintain orientation and location (3)				Holding down required during subsequent processes to maintain orientation at location (3)					
		Easy to align and position during assembly (4)		Not easy to align or position during assembly		Easy to align and position during assembly (4)		Not easy to align or position during assembly			
		No resistance to insertion	Resistance to insertion (5)	No resistance to insertion	Resistance to insertion (5)	No resistance to insertion	Resistance to insertion (5)	No resistance to insertion	Resistance to insertion (5)		
		0	1	2	3	6	7	8	9		
Addition of any part (1) where neither the part itself nor any other part is finally secured immediately Part and associated tool (including hands) can easily reach the desired location	0	1.5	2.5	2.5	3.5	5.5	6.5	6.5	7.5		
	1	4	5	5	6	8	9	9	10		
	2	5.5	6.5	6.5	7.5	9.5	10.5	10.5	11.5		
Part and associated tool (including hands) cannot easily reach the desired location Due to obstructed access or restricted vision (2)											
Part and associated tool (including hands) cannot easily reach the desired location Due to obstructed access and restricted vision (2)											
Addition of any part (1) where the part itself and/or other parts are being finally secured immediately Part and associated tool (including hands) can easily reach the desired location and the tool can be operated easily	0	1	2	3	4	5	6	7	8	9	
	3	2	5	4	5	6	7	8	6	8	
	4	4.5	7.5	6.5	7.5	8.5	9.5	10.5	11.5	8.5	10.5
Part and associated tool (including hands) cannot easily reach desired location or tool cannot be operated easily Due to obstructed access or restricted vision (2)											
Part and associated tool (including hands) cannot easily reach desired location or tool cannot be operated easily Due to obstructed access and restricted vision (2)											
Addition of any part (1) where the part itself and/or other parts are being finally secured immediately Part and associated tool (including hands) can easily reach the desired location and the tool can be operated easily	5	6	9	8	9	10	11	12	13	10	12
Part and associated tool (including hands) cannot easily reach desired location or tool cannot be operated easily Due to obstructed access and restricted vision (2)											
Mechanical fastening processes (part(s) already in place but not secured immediately after insertion)	None or localized plastic deformation			Bulk plastic deformation (large proportion of part is plastically deformed during fastening)	Non-mechanical fastening processes (part(s) already in place but not secured immediately after insertion)						
	Bending or similar process	Riveting or similar processes	Screw tightening or other processes		Metallurgical processes		Additional material required		Chemical processes (e.g., adhesive bonding, etc.)	Manipulation of parts or sub-assembly (e.g., orienting, fitting or adjustment of part(s), etc.)	Other processes (e.g., liquid insertion, etc.)
					No additional material required (e.g., resistance, friction welding etc.)	Soldering processes	Weld/braze processes				
0	1	2	3	4	5	6	7	8	9		
9	4	7	5	12	7	8	12	12	9	12	

Key:  
 PART ADDED but NOT SECURED

PART SECURED IMMEDIATELY

SEPARATE OPERATION

Assembly processes where all solid parts are in place

Figure O.1 Classification System Calculation Sheets<sup>209</sup>

<sup>209</sup> Boothroyd et al., p. 232

## Appendix P: Additional Images of Design Changes

### Design Change 1

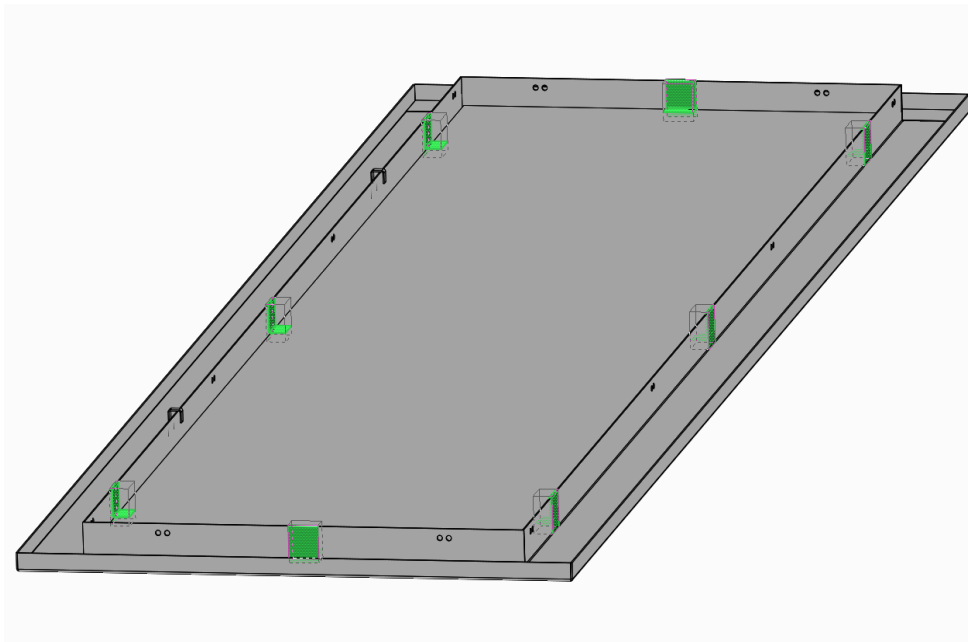
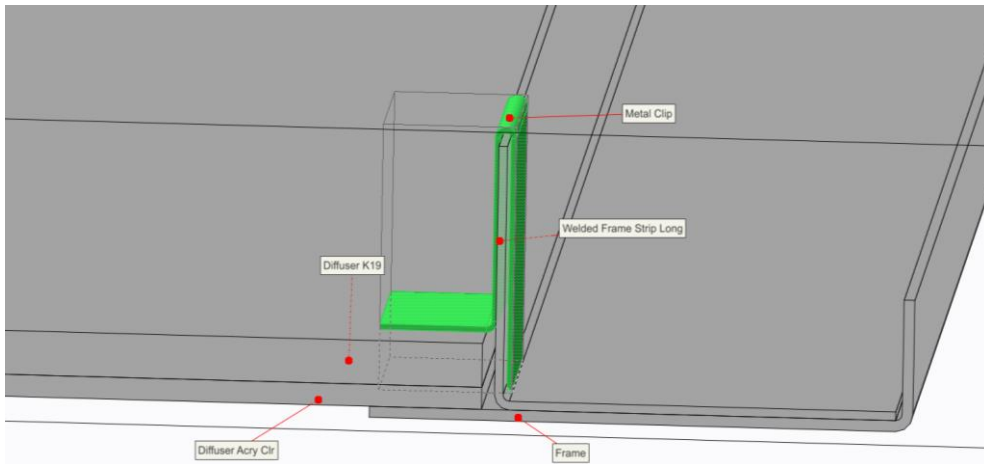

## Design Change 2

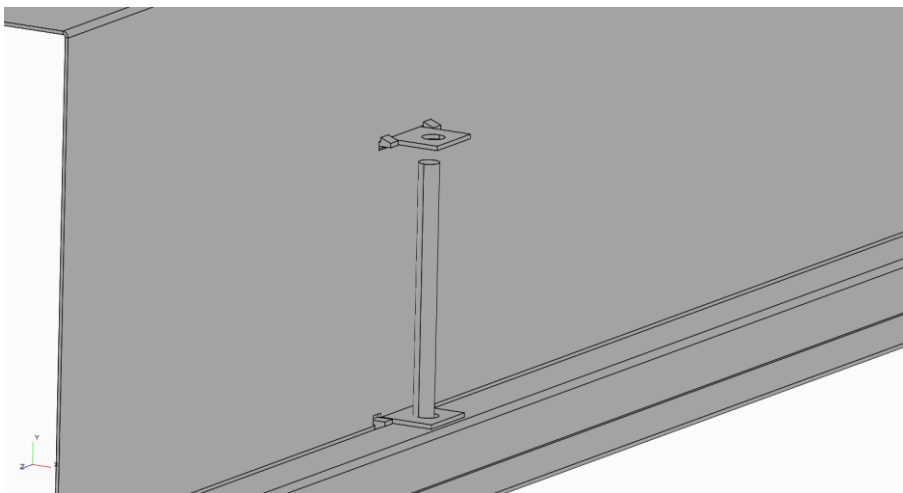
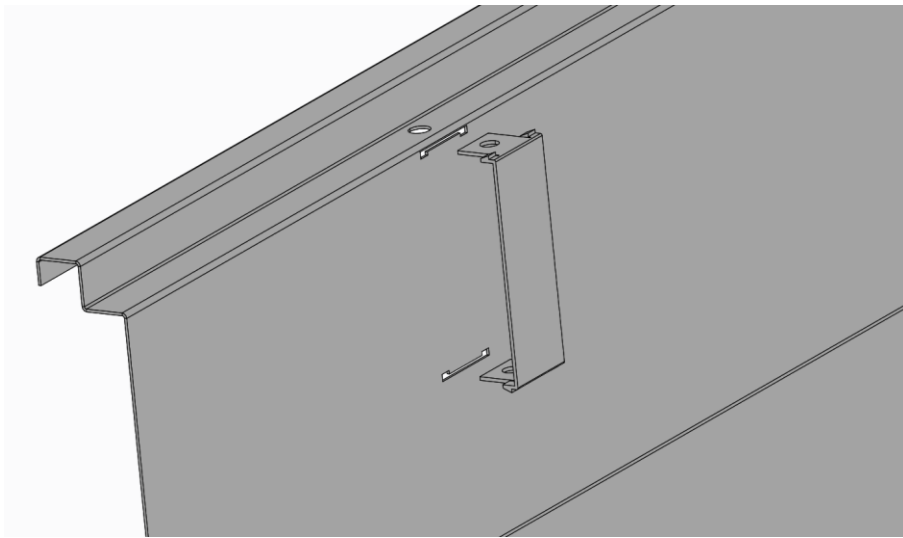
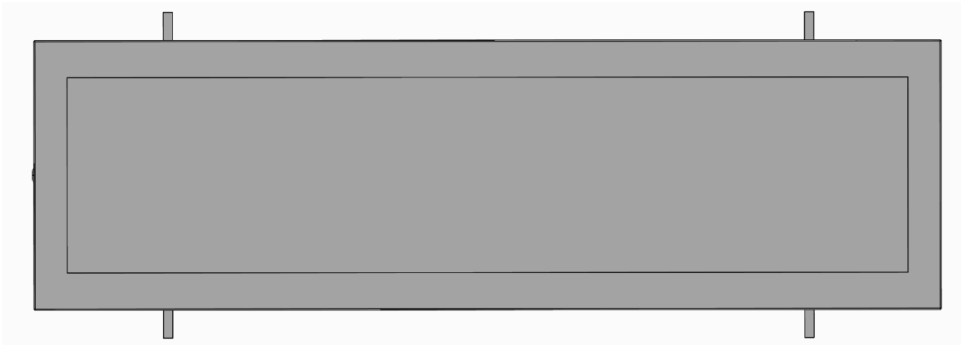

**Design Change 3**

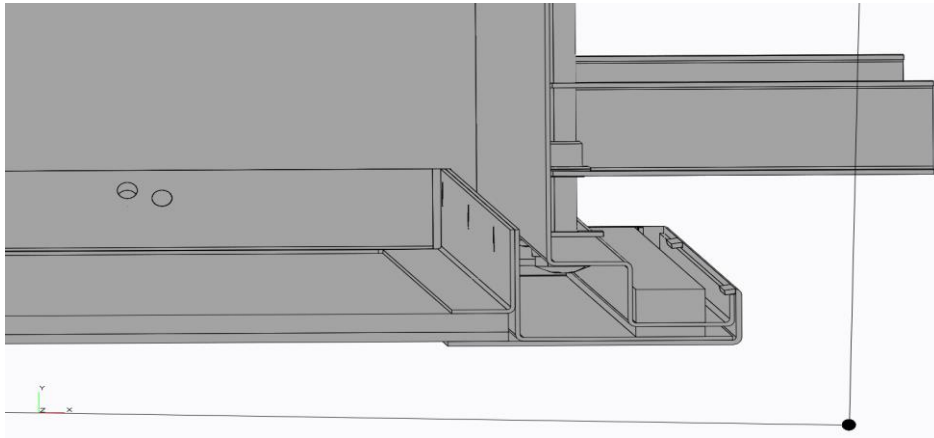
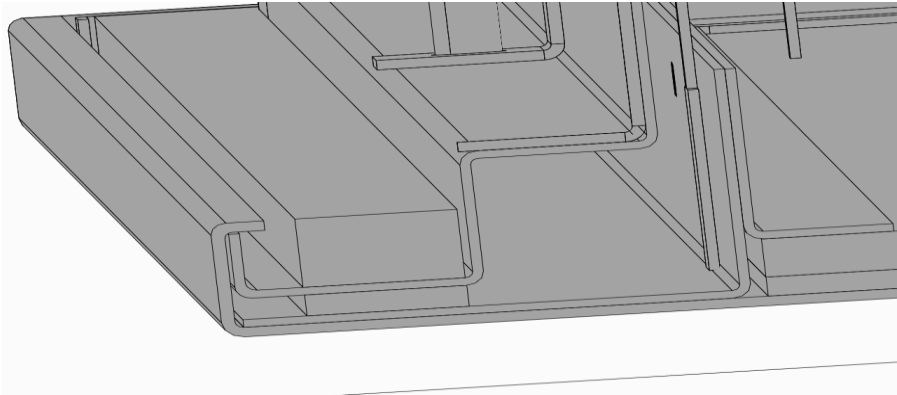

**Design Change 4**

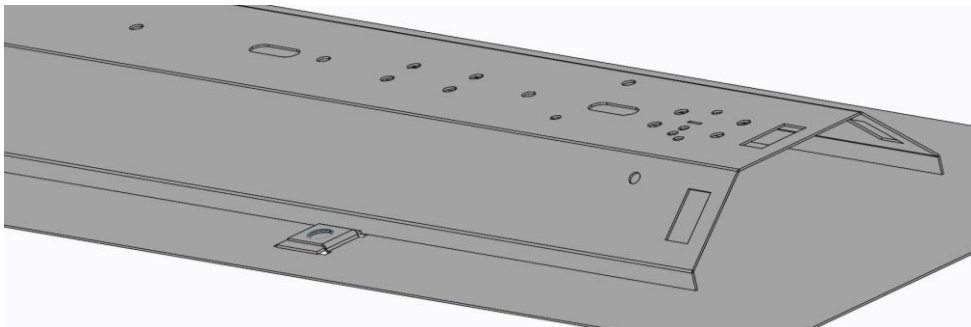

## Appendix Q: Updated DFMA Worksheet & Design Changes

Table Q.1 Updated DFMA Worksheet

part number	number repeats	handling code	handling time (sec)	insertion code	insertion time (sec)	total assembly time (sec)	manual assembly cost (\$)	min number of parts	Remarks	material costs (\$)
<b>1 Silicon</b>	4			99	12	48	0,528		apply in corners all around frame	0,4
<b>2 Diffuser acry clr 2 mm</b>	1	85	5	00	1,5	6,5	0,0715	1	remove protection tape then place in fram	5,75
<b>3 Diffuser K19</b>	1	90	2	00	1,5	3,5	0,0385	1	place in frame	10,41
<b>4 Zinc Clips</b>	6	30	1,95	30	2	23,7	0,2607		place and snap fasten	6
<b>6 Reorientation</b>	1			98	9	9	0,099		reorient frame when fastening strips	0
<b>10 Body</b>	1	95	4	00	1,5	5,5	0,0605	1	place on workbench	20
<b>12 Toggle rec arm washer</b>	4	01	1,43	00	1,5	11,72	0,12892		place into bolt	0,4
<b>13 Toggle rec arm bolt</b>	4	10	1,5	38	6	30	0,33		place into bracket and screw to arm	0,4
<b>14 Toggle rec arm</b>	4	30	1,95	00	1,5	13,8	0,1518	4	placed in bracket	4
<b>15 Toggle rec arm nut</b>	4	01	1,43	38	6	29,72	0,32692		nut fastened to bolt	0,2
<b>16 Toggle rec arm brackets</b>	4	20	1,8	30	2	15,2	0,1672		place and snap fasten	
<b>17 Reorientation</b>	1			98	9	9	0,099		reorient body	
<b>18 Gasket tape</b>	4			99	12	48	0,528		Apply gasket tape	12

<b>19 Terminal block</b>	1	30	1,95	30	2	3,95	0,04345	1	place in frame and snap fasten	0,33
<b>21 Ballast</b>	1	30	1,95	00	1,5	3,45	0,03795	1	place on gear tray	6,31
<b>22 Ballast rivets</b>	2	11	1,8	35	7	17,6	0,1936		place and screw fasten	0,2
<b>25 Reorientation</b>	1			98	9	9	0,099		turn gear tray over	0
<b>26 Wires</b>	7	91	3	38	6	63	0,693	7	place and screw fasten	0,7
<b>27 Lamp holder</b>	4	30	1,95	00	1,5	13,8	0,1518	4	place and snap fasten	0,72
<b>28 Cable gland</b>	1	10	1,5	48	8,5	10	0,11	1	place and screw fasten	1,5
<b>29 Reorientation</b>	1			98	9	9	0,099		Place gear tray in body	0
<b>30 Flex and plug</b>	1	83	5,6	38	6	11,6	0,1276	1	place and screw fasten	1,55
<b>31 Gear tray</b>	1	91	3	30	2	5	0,055		place and snap fasten	17,8
<b>33 Lamps</b>	2	10	1,5	30	2	7	0,077	2	place and twist fasten	5
<b>34 Frame</b>	1	91	3	30	2	5	0,055	1	place and snap fasten	15
<b>SUM</b>	<b>58</b>					<b>412,04</b>	<b>4,53244</b>	<b>25</b>		<b>108,67</b>

Table Q.2 Suggested Design Changes

Number	Design Change	Items	Time Saving (sec)	Cost Saving (\$)	Comments
1	Replace the frame strips with snap fit clips made in zinc, eliminating 12 rivets	4, 5, 6, 7, 34	113,1	6,1048	Eliminate turrets, folding, painting
2	Redesign rec arms and brackets to be made in plastic or aluminium and snap fit brackets onto body, rec arms with threads, eliminate 6 plugs and decrease to 4 instead of 6 and	10, 11, 12, 13, 14, 15	65,42	3,51962	Eliminate welding process + cheaper material
3	Redesign frame to snap fit onto body, eliminating 4 torsion springs, reorientation, 4 hooks and 4 torsion brackets	8, 9, 10, 34	41,44	2,41584	Eliminate welding process + hooks + brackets
4	Redesign gear tray to snap fit into body, eliminating 2 screws and 2 Z brackets	10, 31, 32	15,1	0,365	Eliminate welding process and Z- brackets
5	Eliminate terminal block screw with a snap fitting	19, 20	7,8	0,1858	
6	Replace bolts and nuts used to fasten ballast with plastic rivets, eliminating reorientation	21, 22, 23, 24	21,86	0,44046	
7	Tighten tolerances on body or use alternative sealing solution such as heat-activated film or tape	10, 17, 34	48	1,16	



## Appendix R: Commonality Calculation Sheet

**Table R.1** Commonality Calculation Sheet

Item Name	Item ID	$\phi$	Price (\$)	$V_1 * Q_{1j}$	$V_2 * Q_{2j}$	$V_3 * Q_{3j}$	$V_4 * Q_{4j}$	$V_5 * Q_{5j}$	$\sum_{t=1}^5 (Q_{tj} V_t)$	$\sum_{j=1}^{39} \sum_{i=1}^5 \phi_{ij} \sum_{t=1}^5 (Q_{tj} V_t)$	$\sum_{j=1}^{39} (P_j \sum_{i=1}^5 (Q_{tj} V_t))$
C1 Diffuser K19 1186x286	510001	2	10.14	89	588	0	0	0	677	13729.56	6864.78
C2 Cord Grip	510002	5	0.05	89	588	89	113	121	1000	250	50
C3 Ballast PC 2x14	510004	2	6.5	0	588	0	0	0	588	7644	3822
C4 Lamp Holder T5	510007	4	0.18	178	2352	0	678	968	4176	3006.72	751.68
C5 Flex & Plug	510010	5	1.55	89	588	89	113	121	1000	7750	1550
C6 W Body T-Bar 228	510014	1	2.56	0	588	0	0	0	588	1505.28	1505.28
C7 Ballast PC 1x14	510037	1	5.93	89	0	89	0	0	178	1055.54	1055.54
C8 Plaster Mounting Bracket	510316	1	0.5	0	0	356	0	0	356	178	178
C9 W Body T-Bar 414	510339	1	2.5	0	0	0	0	121	121	302.5	302.5
C10 Diffuser K19 586x586	510343	2	10.27	0	0	0	113	121	234	4806.36	2403.18
C11 W Body T-Bar 314	510344	1	2.05	0	0	0	113	0	113	231.65	231.65
C12 Cover Plate 414	510347	1	2.5	0	0	0	0	121	121	302.5	302.5

C13 Cover Plate 1/3 14	510358	1	3.14	0	0	0	113	0	113	354.82	354.82
C14 W Body T- Bar 128	510362	1	2.05	89	0	0	0	0	89	182.45	182.45
C15 Cover Plate 128	510364	1	2	89	0	0	0	0	89	178	178
C16 Diffuser K19 1205x289	511155	1	10.41	0	0	89	0	0	89	926.49	926.49
C17 Cover Plate 228	511165	1	3.07	0	588	0	0	0	588	1805.16	1805.16
C18 Lamp Holder	511175	1	0.18	0	0	178	0	0	178	32.04	32.04
C19 W Body PC 128	511371	1	8.41	0	0	89	0	0	89	748.49	748.49
C20 Ballast PC 3/4/14	519135	2	7.95	0	0	0	113	121	234	3720.6	1860.3
C21 Terminal Block	519960	5	0.46	89	588	89	113	121	1000	2300	460
C22 End Cap PC 128	522970	1	1.5	0	0	178	0	0	178	267	267
C23 Lamp Holder Bracket	510015	4	0.041	178	2352	0	678	968	4176	694.88	173.7216
C24 Body T- Bar 314	510345	1	9.5	0	0	0	113	0	113	1073.5	1073.5
C25 End Cap T- Bar 128	510357	1	1.5	178	0	0	0	0	178	267	267
C26 Body T- Bar 414	510353	1	8.5	0	0	0	0	121	121	1028.5	1028.5
C27 Body T- Bar 128	510363	1	7.13	89	0	0	0	0	89	634.57	634.57
C28 Body T- Bar 228	510340	1	7.13	0	588	0	0	0	588	4192.44	4192.44
C29 End Cap T-	510346	1	1.5	0	0	0	226	0	226	339	339

Bar 314											
C30 End Cap T-Bar 228	510017	1	1.25	0	1176	0	0	0	1176	1470	1470
C31 End Cap T-Bar 414	510354	1	1.5	0	0	0	0	242	242	363	363
C32 Body PC 128	522969	1	8	0	0	89	0	0	89	712	712
C33 Lamp T5 28W	511426	3	2	89	1176	89	0	0	1354	8124	2708
C34 Lamp T5 14W	511417	2	1.71	0	0	0	339	452	791	2705.22	1352.61
C35 Gear Cover Bracket	522952	2	0.5	0	1176				1176	1418	709
C36 Body clip FT5	522973	1	0.4	0	0	534	0	0	534	213.6	213.6
C37 Gear tray CCL 1-2-3	519298	1	3	0	0	89	0	0	89	267	267
C38 Gear tray mounting bracket	519696	1	0.5	0	0	178	0	0	178	89	89
C39 Frame	522972	1	6	0	0	89	0	0	89	534	534

## **Appendix S: Component Structure Tree**

The authors have used a similar component structure tree as is explained in Appendix U but with an added color-coding feature.

Components that are shared between the products are green, components that are not shared but could be are yellow, and components that are not shared and cannot be or would not gain from it are red. This is done to visually help find areas of improvements for the redesign. An example is item 35, gear cover bracket, which is coloured red in the FT5-228-100-000. This is because it is only used in that product and is not be necessary in any other product in that group and thus would not give an added customer value if added to them.

An initial analysis of the five products divides them into two groups based on their similar dimensions. The colour-coding is only relevant for products within its own group and not between products across the two groups.

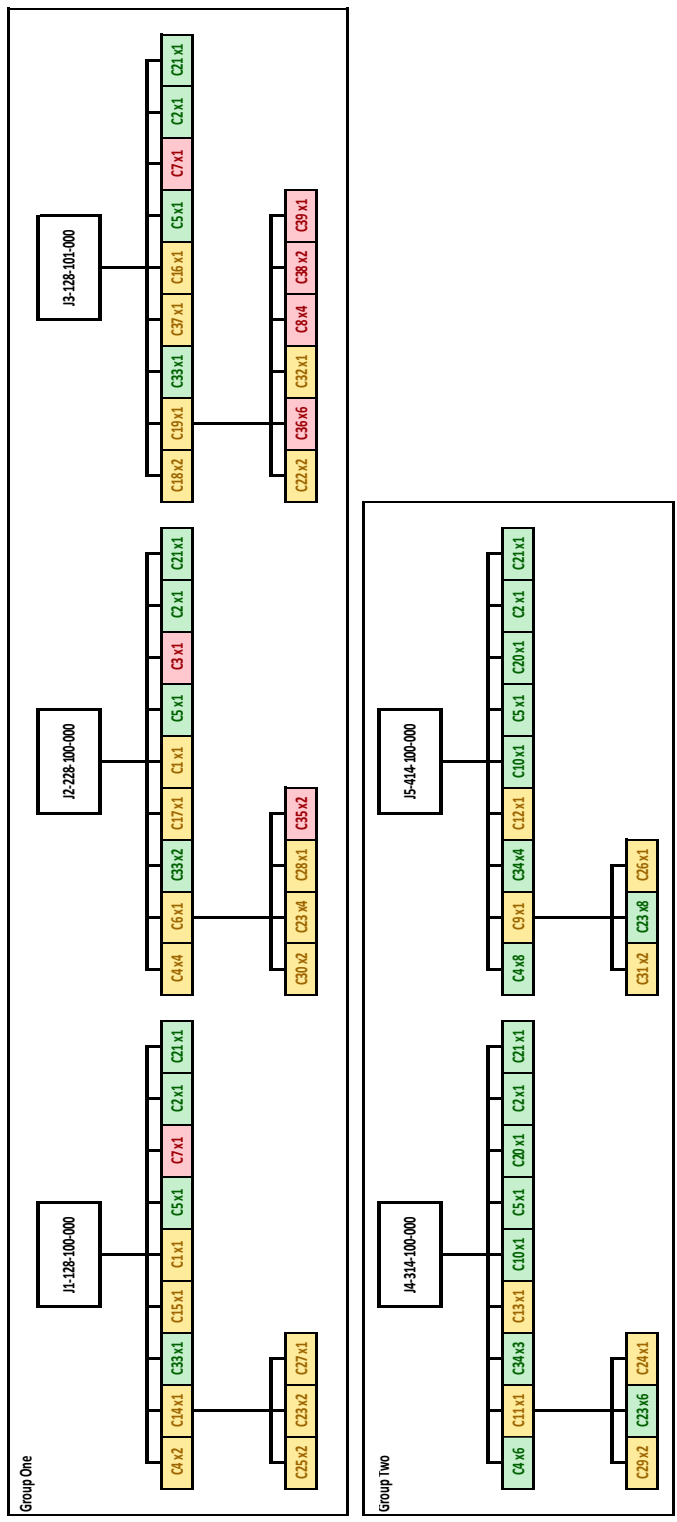

## Appendix T: Exploded Views of Product Family J's Product

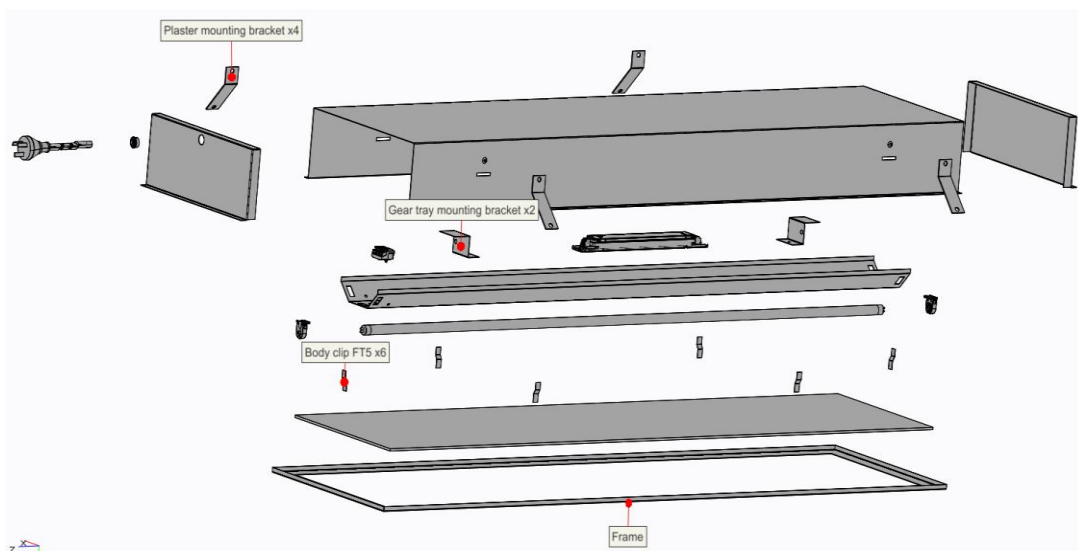
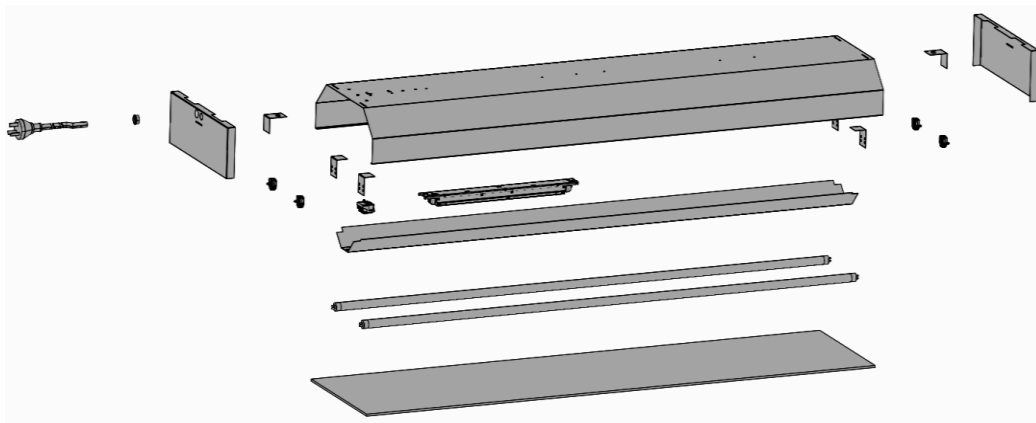

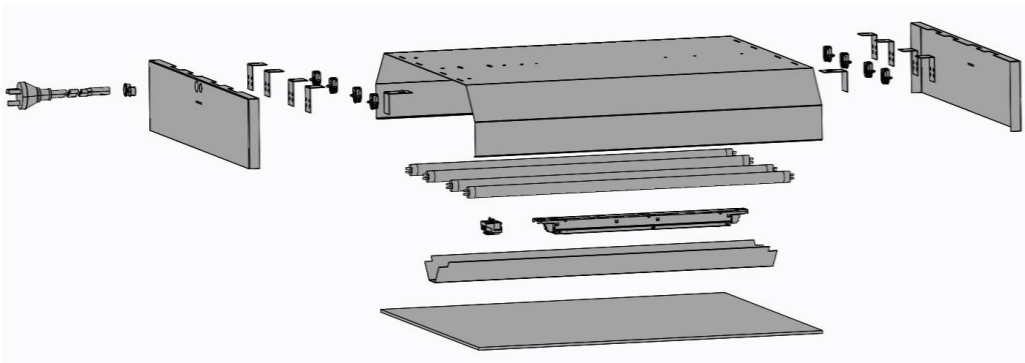
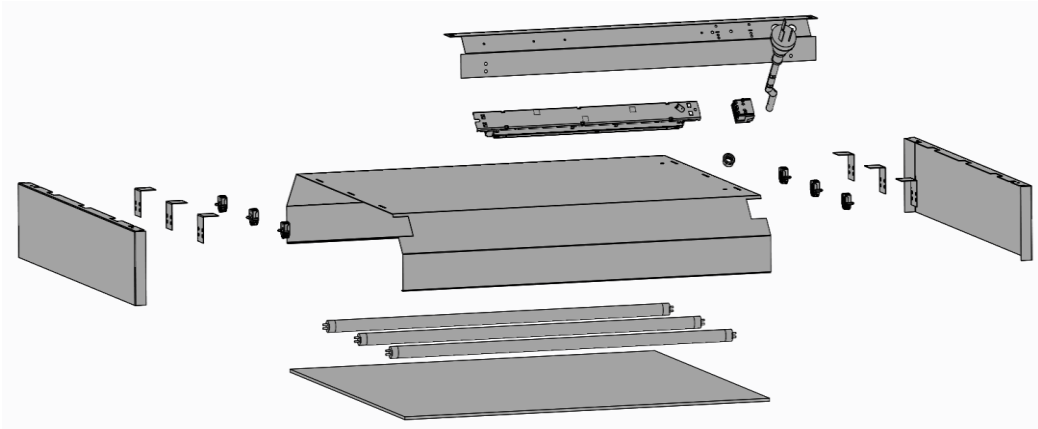

## Appendix U: Commonality Index

As there are several commonality indexes with varying complexity and data needed, an investigation is conducted to find one suited for the task.

Metric	Name	Developed by	Commonality measure for	Lowest value	Highest value
DCI	Degree of Commonality Index	Collier (1981)	The whole family	1	$\beta = \sum_{j=i+1}^{i+d} \Phi_j$
TCCI	Total Constant Commonality Index	Wacker and Trelevan (1986)	The whole family	0	1
CI	Commonality Index	Martin and Ishii (1996, 1997)	The whole family	0	1
CI <sup>(C)</sup>	Component Part Commonality Index	Jiao and Tseng (2000)	The whole family	1	$\alpha = \sum_{j=1}^d \sum_{i=1}^m \Phi_{ij}$
PCI	Product Line Commonality Index	Kota <i>et al.</i> (2000)	The whole family	0	100
%C	Percent Commonality Index	Siddique <i>et al.</i> (1998)	Individual products within a family	0	100
GVI	Generational Variety Index	Martin and Ishii (2002)	Individual components within each product	0	$9 \times (\text{number of engineering metrics})$
Coupling Index	Coupling Index	Martin and Ishii (2002)	Individual components within each product	0	$9 \times (\text{number of parts} - 1) \times (\text{number of flows})$
FSI	Functional Similarity Index	McAdams and Wood (2002)	Individual products within a family	0	1
NCI	Non-Commonality Index	Simpson <i>et al.</i> (2001)	Individual products within a family <sup>a</sup>	0	1
PDI	Performance Deviation Index	Simpson <i>et al.</i> (2001)	Individual products within a family	0	1
CDI	Commonality Versus Diversity Index	Alizon <i>et al.</i> (2006)	Individual products within a family and the whole family	0	1

**Figure U.1**<sup>210</sup> Different commonality indexes examined

Component Part Commonality Index ( $CI^{(C)}$ ) was chosen because of the index's manageable complexity to calculate and the useful information acquired about the examined products. Taking into account the products' component cost and volume made this index stand out from most other indexes. The fact that component cost is included means that expensive components shared between different products give a higher impact on the index value than inexpensive components. This makes the index more practical since, for example, a frame of a fitting shared between products would be more desirable for the company than a shared screw.

$$CI^{(C)} = \frac{\sum_{j=1}^d (P_j \sum_{i=1}^m \Phi_{ij} \sum_{i=1}^m (V_i Q_{ij}))}{\sum_{j=1}^d (P_j \sum_{i=1}^m (V_i Q_{ij}))}$$

In the equation above  $d$  represents the number of distinct components in the chosen products that are examined.  $P_j$  represents the price of component  $j$ . The  $m$  represents the number of products in the family that are examined. The  $\Phi_{ij}$  represents the number of repetitions a distinct component  $j$  has in product  $i$ . For example, component d4 in figure R.2 below occurs once in Product 1, once in Product 2, and zero times in Product 3. This gives component d4 a  $\sum \Phi_{ij}$  of one plus one which

<sup>210</sup> Trevenholt *et al.*, p. 579, 2007



equals two. This is visualised in figure R.3 below.  $V_i$  represents the yearly produced volume of product  $i$ .  $Q_{ij}$  represents the quantity of component  $j$  in product  $i$ .

The disadvantage of this index is that it is not based on a percentage, as is the case with most of the indexes. This means that the calculated index of the current state of the product family is difficult to interpret as it cannot be compared to a set scale (0-100) and thus does not tell the reader if the value is acceptable or not. It is only when a redesign is made and a new index is calculated that these two can be compared and give an indication of whether the redesign is an improvement or not and by how much.

In order to calculate the index all the components included in the five examined products was first attained through their BOMs. Component costs, yearly volume, and quantity per product was also obtained and included into the table shown below in Appendix R.

A component structure tree for every product examined is also established where parent-child relations between components is illustrated. This is used in order to calculate the  $\Phi$ -value of the components and to help illustrate the products' structural design. An example of a component structure tree is seen in the figure R.2 below along with the calculation sheet used to calculate the index seen in figure R.3.

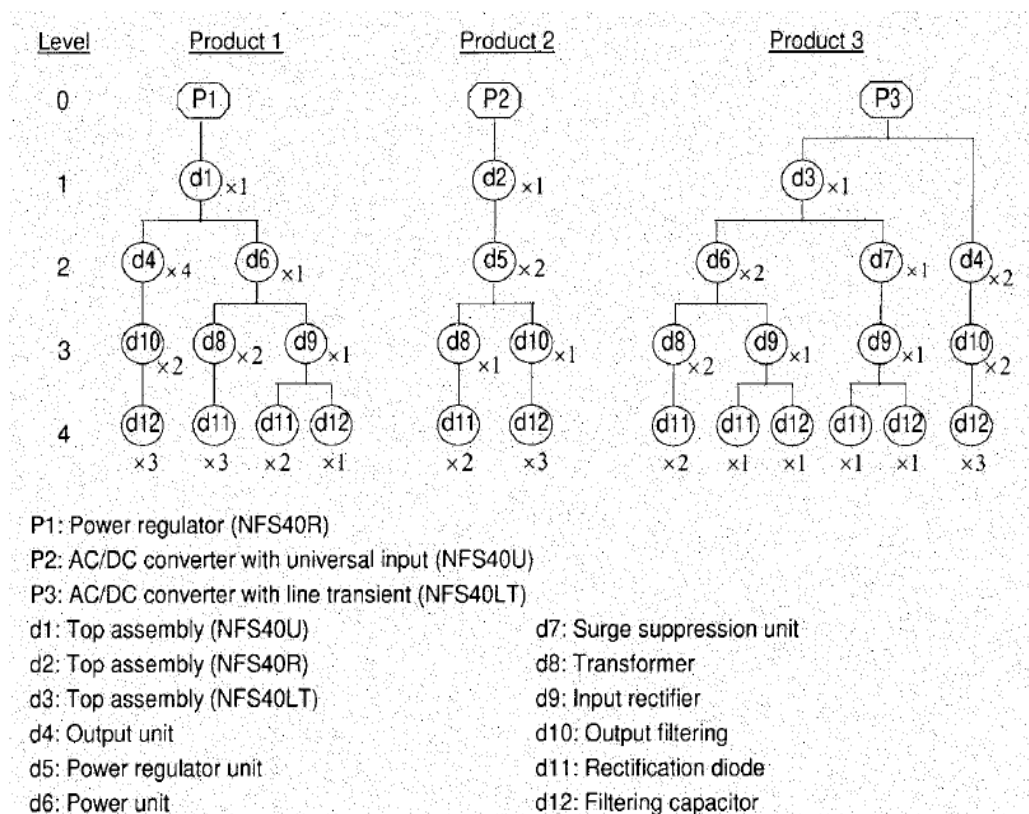
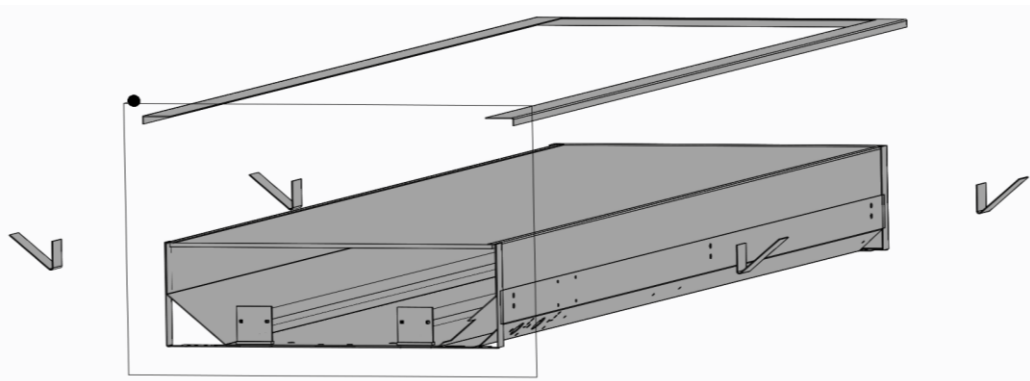
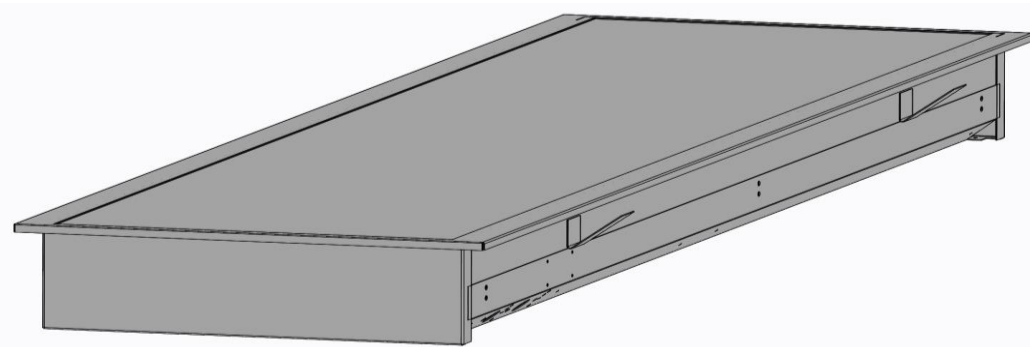
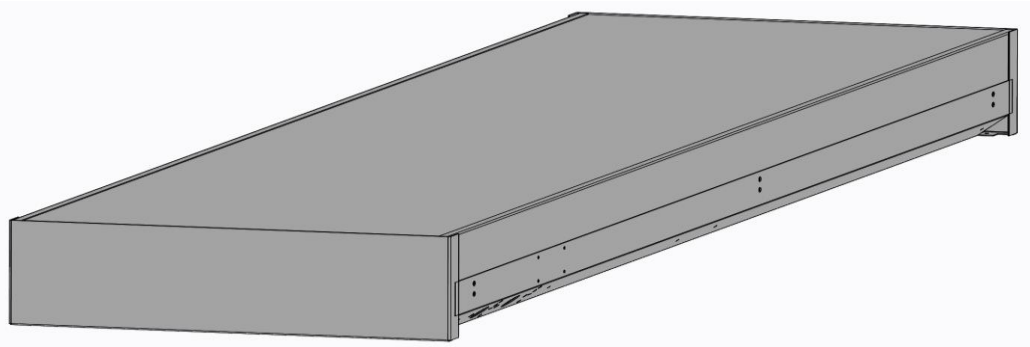

**Figure U.2** Component structure tree

$d_j$	$P_j$	$\sum_{i=1}^3 \Phi_{ij}$	$V_1 = 100,$ $Q_{1j}$	$V_2 = 80,$ $Q_{2j}$	$V_3 = 50,$ $Q_{3j}$	$\sum_{i=1}^3 (V_i Q_{ij})$	$P_j \sum_{i=1}^3 \Phi_{ij}$	$\sum_{i=1}^3 (V_i Q_{ij})$	$P_j \sum_{i=1}^3 (V_i Q_{ij})$
$d_1$	6.4	1	1	0	0	100	640	640	640
$d_2$	2.8	1	0	1	0	80	224	224	224
$d_3$	7.1	1	0	0	1	50	355	355	355
$d_4$	3.1	2	4	0	2	500	3100	1550	1550
$d_5$	3.9	1	0	2	0	160	624	624	624
$d_6$	6.8	2	1	0	2	200	2720	1360	1360
$d_7$	4.1	1	0	0	1	50	205	205	205
$d_8$	3.7	3	2	2	4	560	6216	2072	2072
$d_9$	1.15	3	1	0	3	250	862.5	287.5	287.5
$d_{10}$	3.5	3	8	2	4	1160	12180	4060	4060
$d_{11}$	1.2	6	8	4	11	1670	12024	2004	2004
$d_{12}$	1.4	6	25	6	15	3630	30492	5082	5082
									$CI^{(C)} = 3.79$

**Figure U.3** Calculation sheet

## Appendix V: Additional Images of Design Changes Made to Product Family J



## Appendix W: Updated Commonality Calculation Sheet

Table W.1 Updated Commonality Calculation Sheet

Name	Item ID	Φ	Price (\$)	$V_1 * Q_1$	$V_2 * Q_{2j}$	$V_3 * Q_{3j}$	$V_4 * Q_{4j}$	$V_5 * Q_{5j}$	$\sum_{i=1}^5 (Q_{ij}V_i)$	$\sum_{j=1}^{39} (P_j \sum_{i=1}^5 \phi_{ij} \sum_{i=1}^5 (Q_{ij}V_i))$	$\sum_{j=1}^{39} (P_j \sum_{i=1}^5 (Q_{ij}V_i))$
C1 Diffuser K19 1186x286	510001	3	10.14	89	588	89	0	0	766	23301.72	7767.24
C2 Cord Grip	510002	5	0.05	89	588	89	113	121	1000	250	50
C3 Ballast PC 2x14	510004	1	6.5	0	588	0	0	0	588	3822	3822
C4 Lamp Holder T5	510007	5	0.18	178	2352	178	678	968	4354	3918.6	783.72
C5 Flex & Plug	510010	5	1.55	89	588	89	113	121	1000	7750	1550
C40 W Body 128TBar/228 TBar		2	4.00	89	588	0	0	0	677	5416	2708
C7 Ballast PC 1x14	510037	2	5.93	89	0	89	0	0	178	2111.08	1055.54
C44 Modified plaster Mounting Bracket		1	0.5	0	0	356	0	0	356	178	178
C10 Diffuser K19 586x586	510343	2	10.27	0	0	0	113	121	234	4806.36	2403.18
C47 W body 314TBar/TBar 414		2	3	0	0	0	113	121	234	1404	702
C13 P Cover Plate 1/3 14	510358	2	3.14	0	0	0	113	121	234	1469.52	734.76
C15 P Cover Plate 128	510364	3	1.2	89	588	89	0	0	766	2757.6	919.2
C46 W body PC 128		1	5	0	0	89	0	0	89	445	445
C20 Ballast PC 3/4/14	519135	2	7.95	0	0	0	113	121	234	3720.6	1860.3
C21 Terminal Block	519960	5	0.46	89	588	89	113	121	1000	2300	460

C41 Modified lamp Holder Bracket		5	0.0416	178	2352	178	678	968	4354	905.632	181.1264
C48 Modified body 314TBar/414 TBar		2	9.5	0	0	0	113	121	234	4446	2223
C25 End Cap 128TBar/228 TBar/128PC	510357	3	1.5	178	1176	178	0	0	1532	6894	2298
C42 Modified body 128TBar/228 Tbar/128PC		3	7.13	89	588	89	0	0	766	16384.74	5461.58
C29 End Cap T-Bar 314	510346	2	2	0	0	0	226	242	468	1872	936
C33 Lamp T5 28W	511426	3	2	89	1176	89	0	0	1354	8124	2708
C34 Lamp T5 14W	511417	2	1.71	0	0	0	339	452	791	2705.22	1352.61
C45 Modified frame		1	5.5	0	0	89	0	0	89	489.5	489.5