

Master Thesis

Mechanical Design of Retail Cameras

Erica Backe & Sara Novak

*Division of Machine Design • Department of Design Science
Faculty of Engineering LTH • Lund University • 2013*



LUND UNIVERSITY



Mechanical Design of Retail Cameras

Erica Backe & Sara Novak

*Division of Machine Design • Department of Design Science
Faculty of Engineering LTH • Lund University • 2013*

Division of Machine Design, Department of Design Science
Faculty of Engineering LTH, Lund University
P.O. Box 118
SE-221 00 Lund
Sweden

ISRN LUTMDN/TMKT 13/5483-SE

Preface

This report is the result of our master's thesis within Mechanical Engineering with Industrial Design. The thesis was carried out at the Division of Machine Design, Faculty of Engineering, Lund University and in collaboration with Axis Communications AB, Department of Product Concept & New Ideas, Lund.

The aim of this project was to develop new opportunities for surveillance in retail environments by creating a camera design with these environments in mind. Specifically, our objective was to develop a casing and bracket for a small, versatile camera inspired by the AXIS P12 series and with focus on high-end stores.

We would like to thank our mentors at Axis Communications AB, Carl-Axel Alm and Viktor Gustafsson, for giving us the opportunity to run this project and supporting us on the way.

We would also like to thank Karl-Axel Andersson, our mentor at Lund University, for supporting and inspiring us throughout this master's thesis.

For inspiration and better understanding of customer requirements we talked to experienced staff at Axis Communications AB. Special thanks to Johan Åkesson, Jens Christian Andersen, Daniel Åhman and Morten Bergström for the helpful information and ideas they provided to us along the way.

Finally, to everyone at the Department of Product Concepts & New Ideas, thank you for the great time we had together with you during these months and for welcoming us into your group.

Lund, July 2013

Erica Backe & Sara Novak

Abstract

This report describes the development of a new design for a small surveillance camera that would bring new opportunities for surveillance in carefully decorated environments. The target group was specified to high-end stores; luxury retailers.

This specific target group has a great interest for new products and trends and stores in the lower price segment are often inspired by the high-end stores. Gaining the interest of high-end retailers in first hand would eventually lead to a broader market for the new camera design.

To gather inspiration of the latest trends and trends to come, design fairs were attended and field studies were made. After a wide benchmarking, a function analysis was put together with prioritised design objectives. With a mood board as inspiration shapes were sketched and sculpted, both two- and three-dimensional. In parallel with the shape study, concepts were generated. These were later organised in groups and evaluated before the concept selection. The selection resulted in a narrowed number of concepts that were further developed.

After tests and evaluations a modular camera system was chosen. The final design proposal is a modular system with two mounting options; one adjustable camera and one fixed camera developed for recessed installation. The system also includes two replaceable base units with different lenses. These can be combined with both the adjustable and the recessed camera, and provide multiple surveillance possibilities.

Both designs can be mounted in either the ceiling or on walls, depending on desired surveillance. The modular system is created to suit the customer requests of customisability and at the same time be very discreet when placed in the intended environments.

Keywords:

Retail Surveillance, Surveillance Camera, Product Design, Axis Communications AB

Sammanfattning

Denna rapport beskriver utvecklingen av en ny design för en liten övervakningskamera. Målet med projektet var att designa en kamera för stilkänsliga butiksmiljöer, kontor och museer där detaljerna generellt sett spelar stor roll. Under projektets gång blev den främsta målgruppen butiksmiljöer, där fokus lades på lyxbutiker. Valet av målgrupp grundades i fältstudier, där slutsatser kunde dras om att dessa butiker var de som hade den allra mest genomtänkta inredningen och därför skulle visa mest intresse för en ny kameradesign. Eftersom lyxbutikerna också har en tendens att inspirera andra blev även detta en anledning till att smalna av målgruppen i början av projektet och på detta sätt långsiktigt tilltala en större marknad.

Den slutgiltiga produkten skulle vara möjlig att masstillverka och tilltala målgruppen. De extremt små övervakningskamerorna från AXIS P12 serien öppnade upp möjligheter för en liten och diskret kameradesign. I bilden nedan visas en av dessa kameror.



Bild 1: En kamera från AXIS P12-serien.

Inspiration till den slutgiltiga designen samlades in under mässor, fältstudier, litteraturstudier och samtal med personer med olika yrkesinriktning på Axis Communications AB. För att komma igång med formgivningen gjordes formstudier, både två- och tredimensionella. Efterhand producerades en mängd skissförslag för kamerans utseende och med jämna mellanrum skedde urvalsprocesser. Dessa urvalsprocesser gjordes några gånger under samtal med personer som jobbar med installation eller försäljning av övervakningskameror. Deras erfarenheter kunde bidra till att skapa en uppfattning om vilka koncept som var intressanta för vidareutveckling.

Parallellt med formstudien gjordes även undersökningar för hur monteringen skulle kunna fungera och hur stor plats de väsentliga komponenterna tog. I ett laboratorium

på Axis Communications AB undersöktes kameravinklar och kameraplaceringar för optimal övervakning i en butik. Detta ledde till att två vidvinkelobjektiv valdes ut, ett objektiv för en fast inspänd montering och ett som skulle kunna fungera med en vinklinsbar design. Det var dessa två koncept som följt med under alla urvalsprocesser. Nästa tanke blev en modulär lösning där flera olika monteringslösningar skulle ingå, och fungera med ett antal olika objektiv. Antalet monteringslösningar reducerades till två stycken, kompletterade med två basenheter innehållande objektiv och kretskort. Bilden nedan visar en matris med de delar som var tänkta att ingå i det modulära systemet.



Bild 2: Matris med det modulära systemets ingående delar.

Det slutliga designförslaget består av två kameror, en justerbar och en fast version. De är designade för att vara diskreta och passa så många användningsområden som möjligt. Den fasta infällda versionen är utformad för att ligga tätt mot tak eller vägg och lämpar sig för mycket vidvinkliga objektiv, medan den justerbara kan vinklas och roteras för att riktas mot önskat område för övervakning. Den justerbara kameran kan användas med olika typer av objektiv beroende på situation och önskemål. I detta projekt har endast vidvinkelobjektiv använts.

Val av material och ytfinhet grundades i en önskan om att produkten ska vara tilltalande när den syns från nära håll, och samtidigt på avstånd naturligt smälta in i inredningen. Bilden nedan visar prototyper av de slutgiltiga designförslagen.

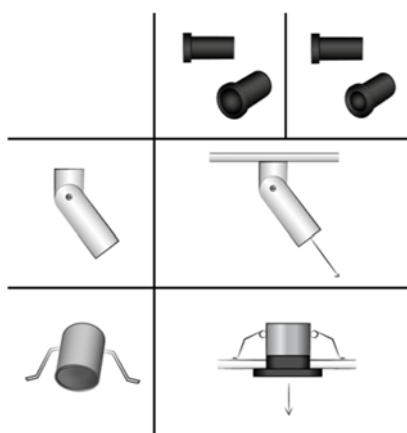

Bild 3: Det slutgiltiga designförslaget.

Table of Contents

1 Introduction	1
1.1 Background and Problem Statement	1
1.2 Axis Communications AB	1
1.3 AXIS P12 series	2
1.4 Components to Consider	3
1.4.1 Circuit Board	3
1.4.2 Image Sensor	4
1.4.3 Lenses	4
1.4.4 Cable	6
1.5 Method	6
1.6 Project Plan	6
1.7 Aims and Delimitations	6
2 Methodology	9
2.1 Applied method – step by step	9
2.2 Pre-study	10
2.2.1 Design Brief	10
2.2.2 Function Analysis	10
2.2.3 Benchmarking	11
2.2.4 Observations	11
2.2.5 Interviews	11
2.3 Concept Generation	12
2.3.1 Mood Board	12
2.3.2 Brainstorming	12
2.3.3 Shape Study	12
2.4 Concept Selection	12
2.4.1 Concept Screening	13
2.4.2 Concept Testing	13

2.4.3 Concept Scoring	13
2.5 Concept Refinement	13
2.6 Discussion	14
3 Pre-study	15
3.1 Design Brief.....	15
3.2 Function Analysis	15
3.3 Benchmarking	17
3.4 Field Studies	19
3.4.1 Stockholm Furniture & Light Fair.....	19
3.4.2 Copenhagen	19
3.4.3 Emporia.....	20
3.4.4 Plastteknik, Malmö.....	20
3.5 Tests in Laboratory	20
3.6 Customer Observations	21
3.7 Interviews	24
3.8 Discussion.....	24
4 Concept Generation	27
4.1 Mood Board.....	27
4.2 Shape Study.....	28
4.3 Brainstorming	30
4.4 Sketch Session	30
4.5 Concept Ideas	30
4.6 Discussion	39
5 Concept Selection	41
5.1 First Selection	41
5.2 Meeting with Italian Luxury Retailer	45
5.3 Concept Testing and Evaluation	46
5.4 Concept Scoring.....	51
5.5 Results and Discussion after Concept Selection	51
6 Concept Refinement	53
6.1 Detail Refinement.....	54
6.2 Colour and Material Selection	57
6.3 Mounting Options	59
6.3.1 Mounting Bracket for the Adjustable Camera.....	60

6.3.2 Mounting Bracket for Recessed Camera	64
6.4 Discussion	66
7 Presentation of Final Proposal	69
7.1 Mounting.....	73
7.2 Materials and Surface Structures.....	76
8 Discussion	79
9 References	83
9.1 Image References.....	84
Appendix A : Initial Project Plan	91
Appendix B : Final Project Plan	93
Appendix C : Interview with Jens Christian Andersen	95
Appendix D : Interview with Daniel Åhman	97
Appendix E : Interview with Johan Åkesson	99
Appendix F : Screen Shots from Tests in Laboratory	101
Appendix G : Concept Scoring	105
Appendix H : Drawings of Final Design	107

Terminology

Below is a description of acronyms and abbreviations used in this report.

3D	Three Dimensional
AB	Aktiebolag (registered company)
Axis	Axis Communications AB
CAD	Computer Aided Design
AXIS P12	Product name for a series of small surveillance cameras developed by Axis
IT	Information Technology
PCNI	Product Concepts and New Ideas, department at Axis
High-end	Luxury Retail
PTC	Parametric Technology Corporation
NCS	Natural Colour System

1 Introduction

This chapter will describe the purpose of the project with its delimitations and give some basic information about the required components of a surveillance camera.

1.1 Background and Problem Statement

The project was started in cooperation with Axis Communications AB to explore new possibilities for camera surveillance within various environments, mainly high-end retail, with inspiration from extremely small cameras like the AXIS P12-series.

The AXIS P12-series is a line of very small surveillance cameras that enable new opportunities for creative design solutions. With constantly changing trends the request for new products and changes in appearance is growing. Customisation is increasingly demanded due to the desire to express the own identity, both concerning individuals and brands. In a store it is important to maintain the branding throughout the whole interior design and furnishing, which could be interpreted as a wish for a discreet design for e.g. surveillance cameras.

Surveillance cameras are used in stores not only to prevent and detect crime but also to optimise sales by monitoring customer behaviour. It is desirable to get a good overview of the store and to capture clear images for identification [1]. A common solution is to place cameras with different fields of view in the ceiling and at eye-level. The same approach is used in hotel receptions and in other public buildings, like museums. The most commonly used camera today is the dome-camera, where the lens direction is covered. The dome-cameras are used together with hidden cameras and/or very explicit cameras to let the visitors know that they are being watched.

Would it be possible to make cameras more adaptable to carefully decorated environments and is there a demand for this type of product on the market?

1.2 Axis Communications AB

Axis Communications AB, hereby referred to as Axis, is an IT company founded in 1984 that works with surveillance cameras. In 1996 the first network camera was introduced by Axis, and network cameras have been their main focus since then [2]. These cameras are connected to a network and image information can be reached through the Internet or intranets.

The company aims to keep their position on the market by constantly developing new and better surveillance solutions to meet the requirements of the market.

1 Introduction

Their philosophy is to “stay one step ahead”. Axis aims to create cameras that are high-performing, aesthetically appealing and easy to install.

The AXIS P12 series is a recently developed line of very small versatile cameras, bringing new opportunities to surveillance. Now Axis is looking for a new design to broaden the opportunities for installation in carefully decorated environments.

1.3 AXIS P12 series

The P12 series currently consists of three types of cameras; two of them developed for indoor use and one for outdoor use. They are covert network cameras designed for environments where it could be desirable to use hidden or very discreet cameras. The two different types of design broaden the mounting possibilities, see Figure 1.1 below [3].



Figure 1.1: The sensor units in the AXIS P12 series. The camera to the left has the dimensions 27 x 20 x 22 mm (H x W x D). The two cameras to the right have a diameter of 20 mm and the longer version is developed for outdoor use [4] - [6].

The cylinder shaped sensor units are threaded for flexible installation possibilities, and the cable comes out through the back in line with the lens. The flattened sensor unit can be mounted with two screws and the cable is perpendicular to the direction of the lens, which makes it suitable for wall mounting.

Each camera in the AXIS P12 series consists of a sensor unit and a main unit, see Figure 1.2. The sensor unit contains a lens, an image sensor and a circuit board. It is connected to the main unit by a cable. The main unit receives information from the sensor unit, and provides connection with the network. The cable between the sensor unit and the main unit can be ordered in lengths up to 8 meters, which makes it easy to hide the main unit in another location.



Figure 1.2: Main unit connected to sensor unit.

1.4 Components to Consider

The sensor unit of a network camera basically needs an image sensor, a lens, a circuit board and a connecting cable, see Figure 1.3.

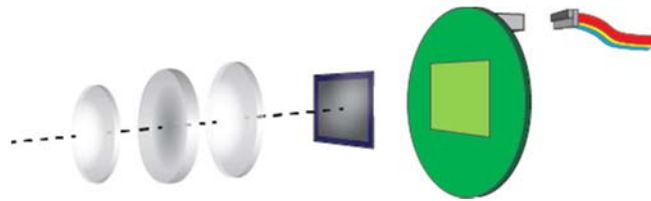

Figure 1.3: Exploded view of lens, image sensor and circuit board.

1.4.1 Circuit Board

The circuit board is a small plate containing the electronic components necessary to transfer the image information to the main unit. Both the image sensor and the connector for the cable are attached to the circuit board. In Figure 1.4 below, the circuit board used in the AXIS P12 series is shown with the cable connector to the left and the image sensor to the right.

The circuit board has a diameter of 16 mm. With the connector, it has a total height of 6.5 mm, and when the cable is connected the assembly measures 7.5 mm in height.

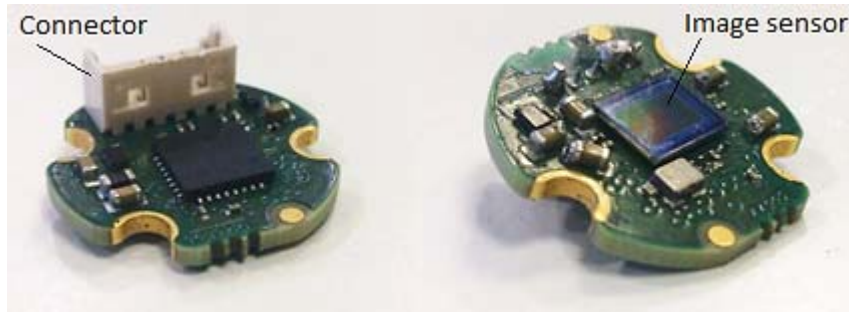

Figure 1.4: Circuit board, bottom and top side.

1.4.2 Image Sensor

The amount of pixels in the image sensor determines the resolution of the picture. The sensors used in the AXIS P12 series have a resolution of 1280 x 720 pixels. A standard image sensor is rectangular, with a base larger than the height. If tilted 90 degrees, the picture will be shown in corridor format. A standard format sensor can cover a large horizontal area while the corridor format could be of good use for close-up identification of people in different heights, see Figure 1.5.



Figure 1.5: From left: corridor format and standard format.

1.4.3 Lenses

There are a number of lenses with different focal lengths available on the market. The focal length determines the field of view, which varies from approximately 10 to 180 degrees. A camera might require a certain field of view depending on its purpose, e.g. people counting, heat tracing and identification. Heat tracing cameras can detect where people stop for longer periods of time; in the picture a colour change is registered. In Figure 1.6 two different types of fisheye-lenses are shown.



Figure 1.6: Two different types of fisheye-lenses.
These lenses were chosen for the camera design in this project.
From the left: *DSL215* and *DSL216* (product names).

A fisheye-lens has an ultra-wide field of view and provides a good overview of a large area but gives a distorted image, see pictures in Figure 1.7 and Figure 1.8 taken with the lenses presented above. With this type of lens it is hard to get clear images for identification due to the reduced amount of pixels per degree in the field of view. A lens with a narrower field of view gives more pixels per object, but requires adjustability to cover the right area.



Figure 1.7: AXIS P1214 with DSL215.



Figure 1.8: AXIS P1214 with DSL216.

1.4.4 Cable

The cable for the AXIS P12 cameras is up to 8 meters long and measures about 5.5 mm in diameter. The final camera design must provide an outlet for a cable. The cable diameter can be decreased, but at the expense of the cable length, due to the electrical resistance in the cable.

1.5 Method

The method used in this project will be a combination of different methodologies, where suitable parts concerning product development and design will be selected. The creative process will mainly be inspired by *Vilda idéer och djuplodande analys* by Jan Landqvist [7]. See Chapter 2 for a detailed description of the method.

1.6 Project Plan

The duration of the project is 20 weeks, from February 2013 to July 2013. It is divided into four parts; Pre-study, Concept Generation, Selection and Refinement. The final design proposal is presented in chapter 7; Presentation of Final Proposal.

The initial project plan is presented in Appendix A and the final project plan is presented in Appendix B.

1.7 Aims and Delimitations

The aim of this thesis is to develop a new casing and bracket for small versatile cameras intended to be placed in high-end retail environments. These environments are chosen because of their carefully decorated interiors that offer an extra challenge in placing surveillance devices. The laws for camera surveillance in the chosen environments will not be taken under consideration; since the cameras are sold all over the world and the laws differ.

Included in the project is to investigate possible mounting places, design trends and general requirements for small cameras in the mentioned environments. The possibility to install the camera in walls and ceilings is necessary and the camera should be able to cover areas where surveillance is requested. Since an identification camera often is hidden it needs no further design. The main focus will therefore be on cameras for video analytics and overview.

The cameras should have a good balance between design, performance and manufacturing possibilities. The design should be aesthetically appealing but also suitable for mass production. To avoid blocking creativity and new ideas there will be no evaluation of production costs.

Materials for the camera casing shall be investigated. The camera design should be made with 3D CAD, using the computer program PTC Creo Parametric. Prototypes should be manufactured using a 3D printer.

2 Methodology

Description and discussion of the chosen methodology.

2.1 Applied method – step by step

In Figure 2.1 below, the applied method is shown schematically.

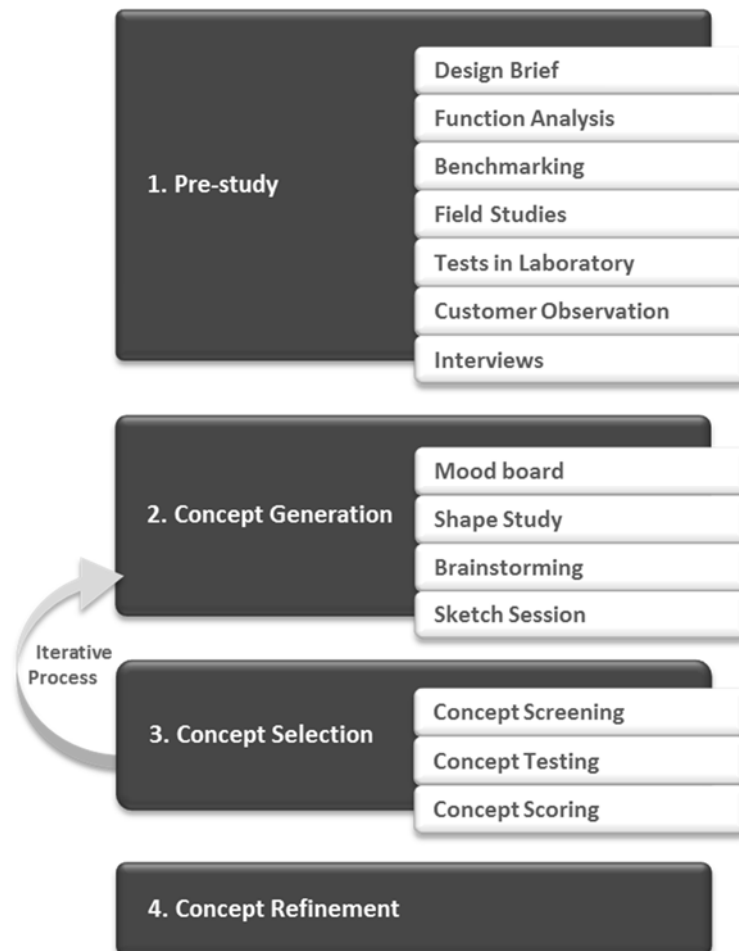

Figure 2.1: Applied method.

2.2 Pre-study

A pre-study is the initial work performed to gain an overview and understanding of the project. The following subchapters will describe the method of the different steps in the pre-study that was carried out in this project. In Chapter 3 the result of the pre-study will be presented.

2.2.1 Design Brief

A design brief is a concisely written summary of the product that will be designed. It can be used as a guideline during the later stages of the design process. To create the design brief presented in chapter 3.1, inspiration was taken from the book *Design'et før design'et* [9]. The bullet points presented below are freely translated from this book and have been used as a structure for the brief.

- Identify what the new product wants to be.
- Describe the main function of the new product.
- See the product as the user would see it.
- Describe the personality of the user and the product.
- Describe the characteristics that determine the perceived value.
- Describe the product's reflection of and contribution to the business image.
- Specify the extent to which a new product shall relate to a product system.
- Identify the elements that determine the product's perceived technical quality.
- Make a storyboard.

A design brief challenges the designer to analyse the customer and the sought perceived value of the product. If the target group is very diverse or if there are multiple target groups, it can be problematic to make a relevant analysis of the customer. Sometimes it is necessary to make more than one design brief. In this project the specified aims and target group facilitated the forming of a design brief and it was not necessary to make more than one.

2.2.2 Function Analysis

A function analysis is established to define and separate the important and desired qualities of the product. Most important is to define the primary function. To create a function analysis [7] a combination of one verb and one noun is presented for each function. These are put together to create a good overview of all the possible requirements. If necessary, a comment can be added in connection to the independent functions to note measurements or give an extra explanation. All the stated requirements are ranked as either necessary or desired. The desired requirements can then be arranged in order of priority. In this report the desired functions are ranked from 1-5, where 1 means most desired and 5 least.

This method is good for quickly stating all the functions of a product that need to be taken under consideration, and minimises the risk of leaving something out which might be of importance later on. A function analysis can beneficially be used as a checklist during the project. The final product should fulfil all necessary requirements and the primary function.

The described method for writing a function analysis was slightly modified. Instead of expressing the function with a combination of only a verb and a noun, which could take an unnecessarily long time to phrase, a free function analysis was made. In the free function analysis two free words were allowed to describe each requirement in order to avoid blocking creativity. This made the process faster and minimised the risk of missing out on important functions. The function analysis presented in chapter 3.2 was put together in parallel with gathering of information in the other subparts of the pre-study.

2.2.3 Benchmarking

Benchmarking is done to investigate and evaluate products of business competitors. This can include making a sector chart, which is a helpful tool to visualise the current market supply. A sector chart is divided into four parts by a vertical and horizontal axis. The axes represent two different product qualities of interest and their antonyms. Examples of such can be “sophisticated” versus “unsophisticated” or “safe” versus “dangerous”. These antonyms are chosen freely by the designers, and the competing products are placed in the diagram according to the subjective opinion of the designers. In chapter 3.3 the sector chart for this project can be viewed.

A sector chart is by no means scientifically accurate and can be misleading in some cases. The purpose of a sector chart is to give the designer a guideline to which the desirable qualities of the final product are. It can also give a hint of any open areas, where none of the competitors have addressed the market.

Besides a sector chart, a table of the competitor’s products can be made to show the different solutions compared to each other [8]. The table should contain the different products, their respective measurements in the various categories and the importance/priority of the categories. If performed in detail, the table will give a clear overview of the advantages and shortages of the competing solutions.

2.2.4 Observations

Observations can e.g. include field studies and laboratory tests. For this project field studies were made to investigate the intended environment for the product and to gather information about typical placements for similar products. Laboratory tests were done to better understand the expected environment of the product. By using different observation methods a more accurate interpretation of customer requirements into customer needs can be made.

2.2.5 Interviews

There are different ways to perform an interview, and the chosen interview method depends on the sought outcome. The main difference in methods is how the questions are phrased; they can be closed versus open. If a closed question is asked, the answer is forced to be short. An open question allows a richer answer. There is also a matter of quality versus quantity; there could be many people briefly interviewed on the topic to gather information about the main opinion, or fewer interviews performed

more thoroughly. In this project longer interviews were performed, with a mixture of open and closed questions.

Meaningful interviews made during this project will be referred to in the report. Some of the interviews were complemented with further conversations later during the project and summaries of the given information can be found in Appendix C, Appendix D and Appendix E.

2.3 Concept Generation

2.3.1 Mood Board

The purpose of a mood board is to define and express the wanted experience of the product with a collage of pictures. The mood board can then be used as a guideline during the concept generation, selection and refinement. It should be possible to see a clear connection between the mood board and the final product. If the pre-study is not thoroughly executed the focus can change during the project and the mood board will then be misleading.

2.3.2 Brainstorming

Brainstorming is a useful method to generate ideas. Brainstorming sessions can be performed in different ways, most common is to gather a group of people and combine their imagination and thoughts to come up with inspiring new ideas. A list of important rules to consider during brainstorming is freely translated and presented below [7].

- No criticism is allowed; a negative attitude can be fatal to the creativity of the group.
- It is important to distinguish criticism from curiosity; one is always allowed to ask if they do not understand.
- No ideas should be kept to oneself; even if it does not seem relevant at the moment, it is of great importance that every idea is presented. Even the wildest ideas can stimulate associations or be modified into something useful.
- One is allowed to modify or build on the ideas of the other group members.

2.3.3 Shape Study

During the concept generation a shape study can be done to investigate possible sizes and shapes and find the most suitable design. A shape study can include sketches and three dimensional models (CAD or hand-made). The shape study in this project is mostly focused on sketches and CAD-models.

2.4 Concept Selection

To select the best concept is difficult. It is important not to jump to any quick conclusions and later in the project realise that a more preferable concept was overseen. In *Product Design and Development*, written by Ulrich and Eppinger [8], *concept screening* and *concept scoring* are two of the presented methods for choosing

among concepts. In these methods decision matrices are used for weighing the different concepts against each other with specified criteria.

There are other methods for choosing among concepts. Product development teams can e.g. let the client make the decision of which concepts to carry on with, or let someone within the team or the company decide. Other tools for choosing a concept could be through surveys or making lists of pros and cons.

2.4.1 Concept Screening

In the concept screening a review of the concepts is made with one concept set as reference. The concept screening is implemented to quickly sort out the best concepts from a large amount of suggestions. Using a matrix it becomes easy to create a good overview of the concepts weighed against each other.

To be able to perform a concept screening with valuable results it is important to have stated and evaluated the criteria in advance. Sometimes a criterion is complex and hard to define, such as “beautiful”. Either the criterion needs to be broken down into measurable criteria based on the interpreted customer needs, or the designer makes a subjective selection from the generated concepts.

In this project the concept screening was performed orally; instead of using matrices the generated concepts were weighed against each other during a group discussion. Objectives from the function analysis were taken under consideration.

2.4.2 Concept Testing

Sometimes concept testing is necessary to get a better idea of the feasibility of the individual concepts. This can be done by making low fidelity models, which are more easily criticised than high fidelity prototypes.

After a first selection, in this project, through concept screening the chosen concepts were tested to investigate their potential before making the next selection through concept scoring.

2.4.3 Concept Scoring

Concept scoring is a more detailed selection method that can be applied after the screening has been done. The criteria are weighed and valued with a percentage, so that the importance of each criterion can be expressed in exact numbers. In a project where the quality of the final results is determined by subjective views, e.g. the “beauty” or “attractiveness” of a product, it becomes more or less irrelevant to work with exact numbers when choosing the winning concept. Though, it is still interesting to consider the relative importance of the stated requirements.

2.5 Concept Refinement

After selecting the best concept a concept refinement might be required. In this stage the development concerns small details and a final touch on the appearance. This can be an iterative process where inspiration can be taken from previous ideas or concepts. In this project the concept refinement will involve sketching, testing and

evaluation to satisfy the intended customers. 3D printed models will be made to evaluate size, function and appearance.

2.6 Discussion

Defining and following a suitable method facilitates the process during a project. A thoroughly tested method usually ensures a good result. Still, one must be aware of the pros and cons of each methodology. If the chosen method includes steps that are not suitable for the current project it is important to be able to question the method and allow modifications.

In this project the presented methodology has been followed, but as earlier mentioned, sometimes modified to better suit the purpose of developing a new camera design.

It is important to perform a benchmarking to see what the market already has to offer and find possible openings for a new product among the existing ones. Sometimes it can be inadvisable to do a benchmarking too early, since that could block the creativity and lower the ambition of the project. It could also have the opposite effect and motivate the project team to find solutions for lacking products on the market.

A sector chart is a useful tool to discover openings on the market, but due to the subjective distribution of the competing products along the axes it could be misleading and also hard to interpret by people not involved in the project. It is therefore important to keep in mind that it is not a scientifically accurate method, but just a guideline; a help to find product concept openings.

It was mentioned that a table of the competitor's products can be made to show the different solutions compared to each other in detail [8]. This could provide a clear overview of the advantages and shortages of the competing solutions. In this project it was chosen not to make a competitor's table to avoid getting narrow-minded. It was important to keep an open mind and welcome all new ideas.

In this project the design brief, mood board and function analysis were put together in parallel to decide the common goal of the project. They were later used as guidelines and checklists during the design process.

3 Pre-study

This chapter presents the results of the pre-study, following the method described in chapter 2.

3.1 Design Brief

The product wants to be an aesthetically appealing addition to the existing product assortment. It wants to express luxury and timelessness. Its design will make it suitable in the market of high-end stores. The main function of the product is to contain a small security camera and direct the camera towards interesting areas of surveillance.

The owner wants the product to be a protection against unwanted actions but does not want it to distract or disturb the main focus of the business. The product's expression and versatility, in both shape and material, will determine the perceived value. The material and appearance will also, together with the versatility concerning options for installation, affect the perceived technical quality of the product.

The project was initiated to explore new possibilities for surveillance within the chosen market. Therefore the resemblance to Axis' previous products is of minor importance. More important is to satisfy the user and make the product contribute to the innovative image of the company.

3.2 Function Analysis

The function analysis was established to separate and define the important and desired qualities of the product. The different functions were classified as needed or desired in Table 3.1. In Table 3.2 the desired functions are ranked from 1-5, where 1 represents "most desired" and 5 "least desired". The function analysis was revised after the statements from the interviews, discussed in chapter 3.7, to confirm the objectives. These corresponded well with the new information.

Table 3.1: Function Analysis

Function	Classification*	Comments
be adaptive	D	appearance
be adjustable	D	redirecting camera during installation
be stable	N	after installation
allow alternative attachment	D	on surfaces with different structures and angles
allow alternative installation	D	e.g. on bracket or wall
allow variation	D	degree of visibility
carry camera	PF	weight
easy installation	D	for installer
enable colouring	D	for customer
possible to manufacture	N	
allow mounting of lens	N	
contain camera	N	size
enable connection	N	diameter cable, cable length, out from casing
be discreet	D	appearance
allow vision	N	for camera
express luxury	D	
be dustproof	D	
be waterproof	D	
allow relocation	D	within shop/reception
resist sunlight	D	colour
resist heat	D	appearance
resist oxidation	D	

* N = necessary, D = desired, PF = primary function

Table 3.2: Ranking of desired functions.

Function	Rank*	Comments
be adaptive	1	appearance
be adjustable	2	redirecting camera during installation
allow alternative attachment	5	on surfaces with different structures and angles
allow alternative installation	5	e.g. on bracket or wall
allow variation	3	degree of visibility
easy installation	1	for installer
enable colouring	2	for customer
be discreet	1	appearance
express luxury	1	
be dustproof	3	
be waterproof	3	
allow relocation	3	within shop/reception
resist sunlight	1	colour
resist heat	1	appearance
resist oxidation	1	

* 1 = most desired, 5 = least desired

3.3 Benchmarking

Investigations of what the market provides within camera surveillance were made. Interesting products from competitors were analysed and placed in a sector chart.

Figure 3.1 shows the first sector chart assembled early in the project. The axes were assigned with the antonyms *harmless* versus *deterrent* and *affordable* versus *high-end*. These antonyms were chosen after a first quick benchmarking, where the prominent differences in camera design could be expressed with these words. Later in the project the antonyms were reconsidered, and the relevance of the axis *harmless* versus *deterrent* was questioned due to the criterion of low visibility, from the function analysis. The area marked with grey represents the area of interest for the final product. It was then questioned if there was an opening on the market for a harmless high-end camera design.



Figure 3.1: Early stage Sector Chart. The grey area indicates the area of interest.

In Figure 3.2 a second sector chart is presented. The axes have new antonyms; *minimalist* versus *complex* and *discreet* versus *visible*. The grey area in the top left corner describes the sought position for the product on the market. This sector chart was done later in the project when a couple of design suggestions had been generated and more information had been gathered through the pre-study. The cameras in the second chart are all relatively small or designed to be discreet, and therefore considered to be typical competitors to the thought product. With the competitors placed in the second sector chart it can be concluded that there is room for a discreet minimalist camera design on the market.

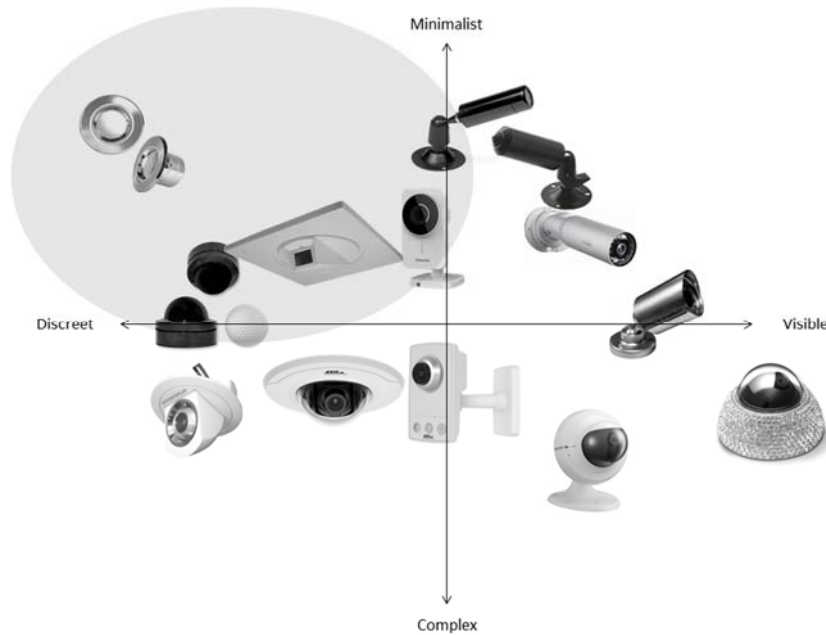

Figure 3.2: New Sector Chart. The grey area indicates the new specified area of interest.

3.4 Field Studies

Field studies were made to investigate the chosen environments. The aim was to find out what potential customers are using today and what could be improved.

3.4.1 Stockholm Furniture & Light Fair

In February a trip to Stockholm Furniture & Light Fair was made to gather inspiration. Companies displayed lightning and furniture installations. There was also a lecture [10] about trend forecasting which gave a useful insight in what will be next within colours and materials in the years to come. Trends, colours, materials and combinations of these, were presented in different ways at the fair.

3.4.2 Copenhagen

In Copenhagen, Denmark, a field trip was made to an area around the street Østergade, where a lot of high-end stores are gathered. Stores like Hugo Boss, Louis Vuitton, Mulberry and Bottega Veneta were studied to gather information about the

surveillance cameras they are using today, their intentions with surveillance, and what they lacked with today's solutions.

The conclusion from this field trip was that the majority of the cameras were placed in ceilings. All ceilings were very pure, with no unnecessary details or equipment showing. This made the surveillance cameras placed in the ceilings very evident. All stores visited used small dome cameras, most of them black, since the black plastic looks less plastic than the white ones.

3.4.3 Emporia

Emporia is a large shopping centre in the Nordic region, located in Malmö, Sweden. It opened in 2012 and has a various selection of stores, including several high-end stores.

There was a big variety of surveillance cameras used in the stores. The main difference from store to store and from the field study in Copenhagen, Denmark, was the interior and the ceilings. At Emporia, most of the stores did not have as carefully decorated interiors or ceilings as the high-end stores in Copenhagen. The pure ceilings made the cameras much more visible. Some stores at Emporia had black painted ceilings, which made the cameras blend in, in contrary to their visibility in the white ceilings.

3.4.4 Plastteknik, Malmö

A visit was made to the fair *Plastteknik* in Malmö; the biggest trade show for the plastic industry in Scandinavia 2013 [11]. Different companies demonstrated their manufacturing methods and various plastic materials.

During a seminar, with the topic *Design that creates a "must-have-reaction"* [12], the need of trend forecasting was discussed. The seminar was held by the design-company Veryday. The importance of having an open dialogue with the customer during the design process was accentuated and interesting ways of evaluating the customer's wishes were mentioned.

3.5 Tests in Laboratory

Tests concerning camera angles and fields of view were performed in a laboratory at Axis. The tests were done to evaluate different camera angles and placements (e.g. by a cash register) and to get a better understanding of the purpose of camera surveillance in stores.

Cameras with different lenses were placed in various positions and snapshots were taken. This was performed to show which angles and placements were the most convenient to get a good overview of the room and/or sharp images for identification. The snapshots can be viewed in Appendix F.

Since most identification cameras are hidden and the purpose of the project was to develop a non-hidden camera, the main focus was on camera angles for video analytics and overview.

During the tests it was concluded that fisheye-lenses were preferable for good overview in the customer environments. Therefore two different fisheye-lenses were chosen as guidelines during the development of the camera.

The laboratory tests gave useful information about where surveillance cameras should be placed in a store. The placement depends on the type of business; high-end retailers usually have guards by the doors and few customers at the same time, whereas petrol stations request visible cameras by the cashier to prevent armed robberies, which are rare in luxury boutiques. The most common crimes in high-end stores are shop-lifting, and therefore the main purpose of surveillance in these environments is to provide a good overview of the area to catch potential thieves.

3.6 Customer Observations

The customers were high-end stores all over the world. Since the main part of the visited stores during the field studies had ceiling mounted cameras, ceilings in high-end stores were investigated.

The collage in Figure 3.3 shows a summary of identified characteristics for the environments. The compilation was based on visits to various high-end stores and pictures of their indoor environments. To describe the environments the words *luxurious*, *balanced*, *interesting*, *clean*, *trendsetter* and *branding* were chosen.

Figure 3.4 shows a compilation of ceilings from different high-end stores. These pictures demonstrate that even the ceilings are well thought-out and carefully decorated. It is important that the cameras blend in with the rest of the interior, and especially in the clean ceilings.



Figure 3.3: Collage of identified customer environment characteristics.

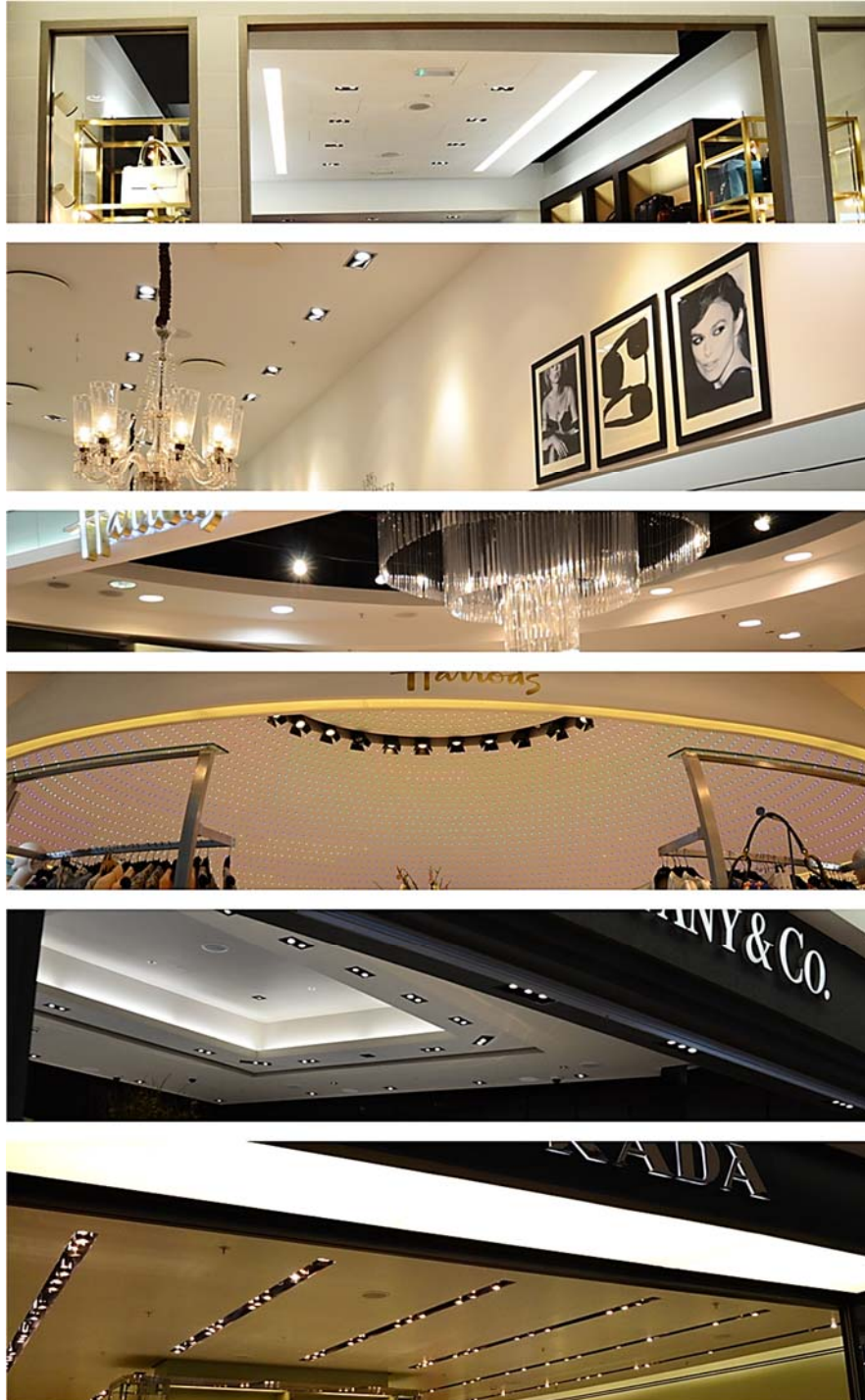

Figure 3.4: Ceilings in high-end stores.

3.7 Interviews

Interviews were performed with employees at Axis. The interviews were open and partially structured with a couple of pre-defined questions. The interviews were performed to gain more information about mounting of surveillance cameras and customer requests; what is lacking in today's products and what could be wished for in a new product.

Jens Christian Andersen, Camera Specialist at Axis, previously worked with camera installations in e.g. high-end stores. Jens Christian Andersen was consulted to gain more knowledge of the purpose of store surveillance, common wall types, customer requirements and the installation process in general. A more thorough description of the discussions with Jens Christian Andersen can be found in Appendix C.

To approach the customers further, Johan Åkesson, Director of Business Development – Retail at Axis, was interviewed. Johan Åkesson has experience from presenting and supplying surveillance solutions for the retail business, including stores in the high-end segment, and thought that a hidden or recessed camera was the best option. He also mentioned that white coloured lenses could be of interest. See Appendix E for more information about the interview with Johan Åkesson.

Daniel Åhman, Design Lead at Axis, had ideas about an architect product line with more focus on the interiors. Daniel Åhman's view was that many high-end stores used the "bullet camera", a cylinder shaped cigar-like camera, discreetly placed in the room. He was of the opinion that discreet cameras were preferred among retailers, and that this project should focus on the same. Daniel Åhman had opinions on guidelines for the final design; such as using the cylinder shape as a base. See Appendix D for more details.

Project supervisors Carl-Axel Alm, Senior Expert Engineer, and Viktor Gustafsson at Product Concepts and New Ideas also came up with a lot of interesting ideas and provided useful information. According to Viktor Gustafsson, round shapes are suitable for ceiling and wall mounting because of the rotational symmetry; placing a square shaped device on a wall requires more accuracy and measuring, to prevent a crooked impression.

White coloured lenses were discussed further with Carl-Axel Alm, after the interview with Johan Åkesson. Changing from the standard black colour would lead to more reflecting light and reduced image quality. Though, the customers could prioritise the reduced visibility of the camera over the image quality, depending on the deterioration.

3.8 Discussion

The pre-study gave a relevant idea about the needs and requirements of the customers. The field studies, including the trip to Copenhagen, confirmed many assumptions about the store interiors, proved that in-store surveillance was very common and that there is room for a new product on the market.

The stores' well thought out interior designs were mostly classic and timeless. Ceiling mounted devices, such as spotlights, were carefully chosen to match the rest of the room. Since the styles in the different boutiques were unique, this was interpreted as a request for a customisable camera.

By summarising a personality for the target group it was easier to decide a preferable design language and expression, suitable for the camera to be developed. The concept generation was initiated during the pre-study to include all spontaneous ideas coming up during this phase. In this report it will be presented as a following step after the pre-study.

The interviews mentioned were followed up with further conversations to involve the employees at Axis in the project development, also to ensure that the common goals were still the same and to gain further information.

4 Concept Generation

This chapter presents the concept generation phase of the project and in subchapter 4.5 the generated concept suggestions are presented.

4.1 Mood Board

A couple of mood boards were made to define the wanted expression of the final product. The final mood board is presented below in Figure 4.1.

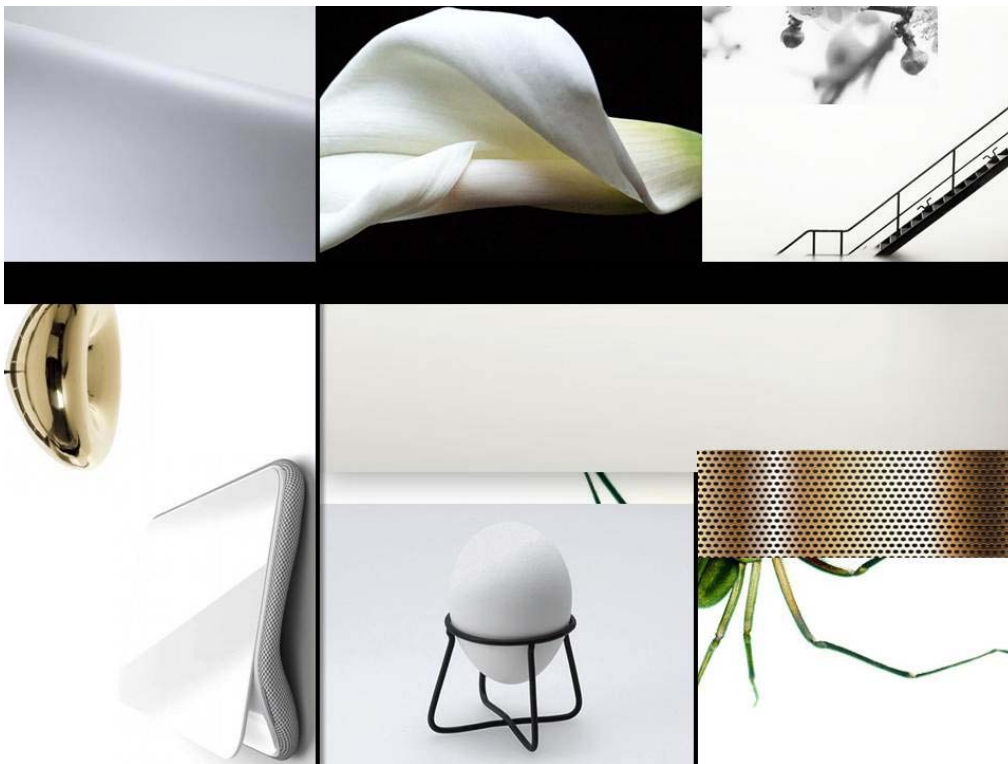

Figure 4.1: Mood Board used as inspiration for the camera design.

4.2 Shape Study

To investigate possible shapes for the camera an extensive shape study was performed. First, an inspirational collage was assembled to make further guidelines for the identity of the product, see Figure 4.2. After that handmade sketches and 3D CAD-models were made, a selection of them can be viewed in Figure 4.3.



Figure 4.2: Inspirational collage with the theme: technology – nature.

The ideas for the inspirational collage were mainly given at the lecture at Stockholm Furniture & Light Fair [10]. The collage represents interesting structures and shapes found in nature and technology. At the trend forecasting seminar environmental challenges were discussed, which were assumed to have an impact on future design trends, since they most likely will affect people's life in general. Nature was assumed to be the sanctuary that human kind will seek for comfort when global warming becomes too much of a threat.

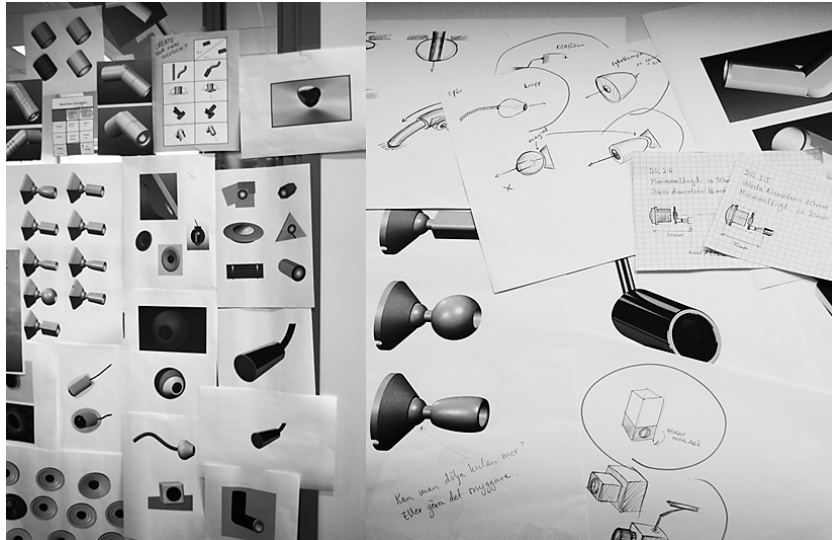

Figure 4.3: 3D CAD models and sketches.

Some three dimensional sketch models were made to investigate the shape and size more thoroughly. These were made out of modelling foam and a selection can be viewed in Figure 4.4.

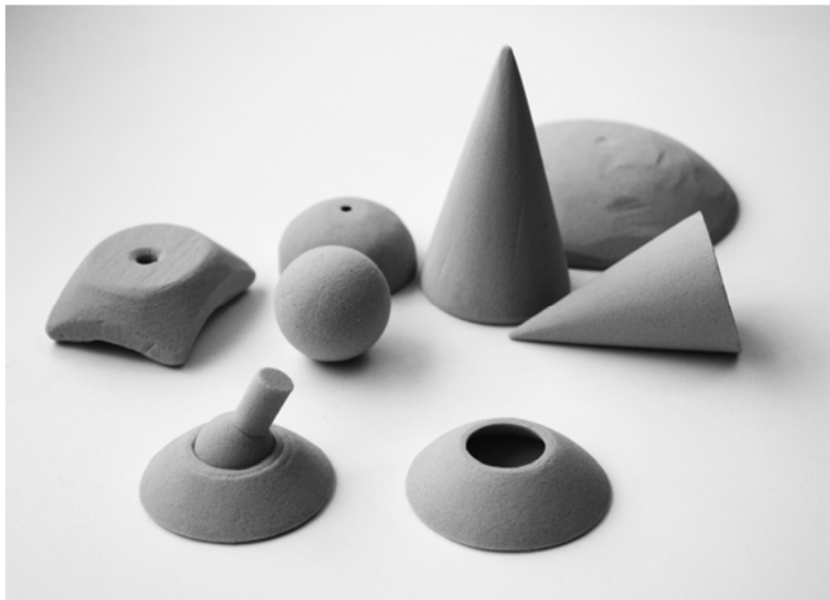

Figure 4.4: A selection of foam models made during the shape study.

4.3 Brainstorming

A brainstorming session was carried out together with eight colleagues from the PCNI department at Axis. To make the group diverse it was necessary to invite people with different backgrounds and experience. The group consisted of five engineers and three master's thesis students, all with different specialisations.

The question formulation was: "How can you turn/rotate something?"

The brainstorming lasted an hour and was divided into shorter sessions where the participants were asked to write down their ideas on a piece of paper. After the first five minutes each paper was passed clockwise around the table. The group was then asked to improve the ideas in front of them or let them inspire to new ideas. After another five minutes the papers were passed clockwise again, and so on.

This brainstorm session led to new ideas of how to redirect a camera. Perhaps there would have been a wider range of ideas if the participants would have had a larger variety of backgrounds; not just engineers.

4.4 Sketch Session

Half way through the project a sketch session was performed with colleagues from the PCNI department at Axis. The group was asked to sketch concepts for a camera design and they were given guidelines like: small camera, hidden, half hidden, on display. This resulted in numerous additions to the already generated concepts.

4.5 Concept Ideas

In this subchapter sketches of concepts, made with the program Adobe Illustrator, are presented. These were the results of the previously presented concept generation; see Figure 4.5 - Figure 4.12.

The presented concept sketches show variations in appearance and function. Some of the concepts are mainly focused on the function, and others explore possible shapes, or a combination of both.

After a consultation with Jens Christian Andersen ^[13] it was concluded that the important ceiling/wall types to consider were drywalls, chipboards and possibly even acoustic panels (usually found in office environments). It was desired to find a mounting solution that enabled easy relocation of the camera when needed.

Inspiration for concept 71 was taken from the AXIS M3011/M3014 camera, which has a specially designed holder that enables easy installation for recessed mounting in ceilings. The mounting bracket is a metal cup with springs that secure the bracket to the ceiling. The camera is then placed in the bracket and the whole package can easily be taken down from the ceiling by loosening the springs. A similar solution at a smaller scale was considered.

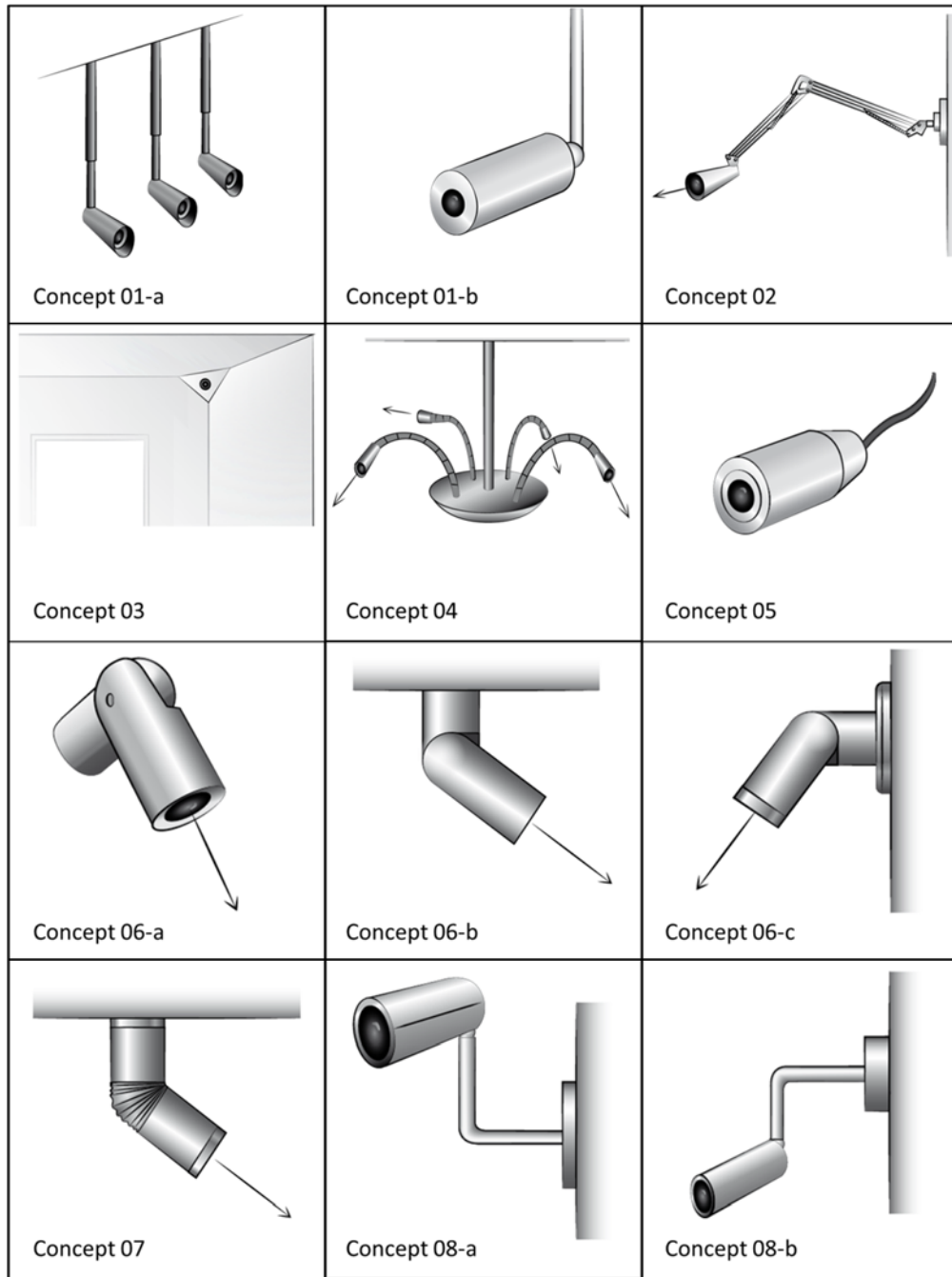

Figure 4.5: Generated concepts.

01: Cylinder camera hanging from ceiling. 02: “Desk lamp”. 03: Triangular corner camera.

04: Multiple cameras on “goosenecks”. 05: Cylinder camera.

06 – 08: Cylinder camera with hidden cable.

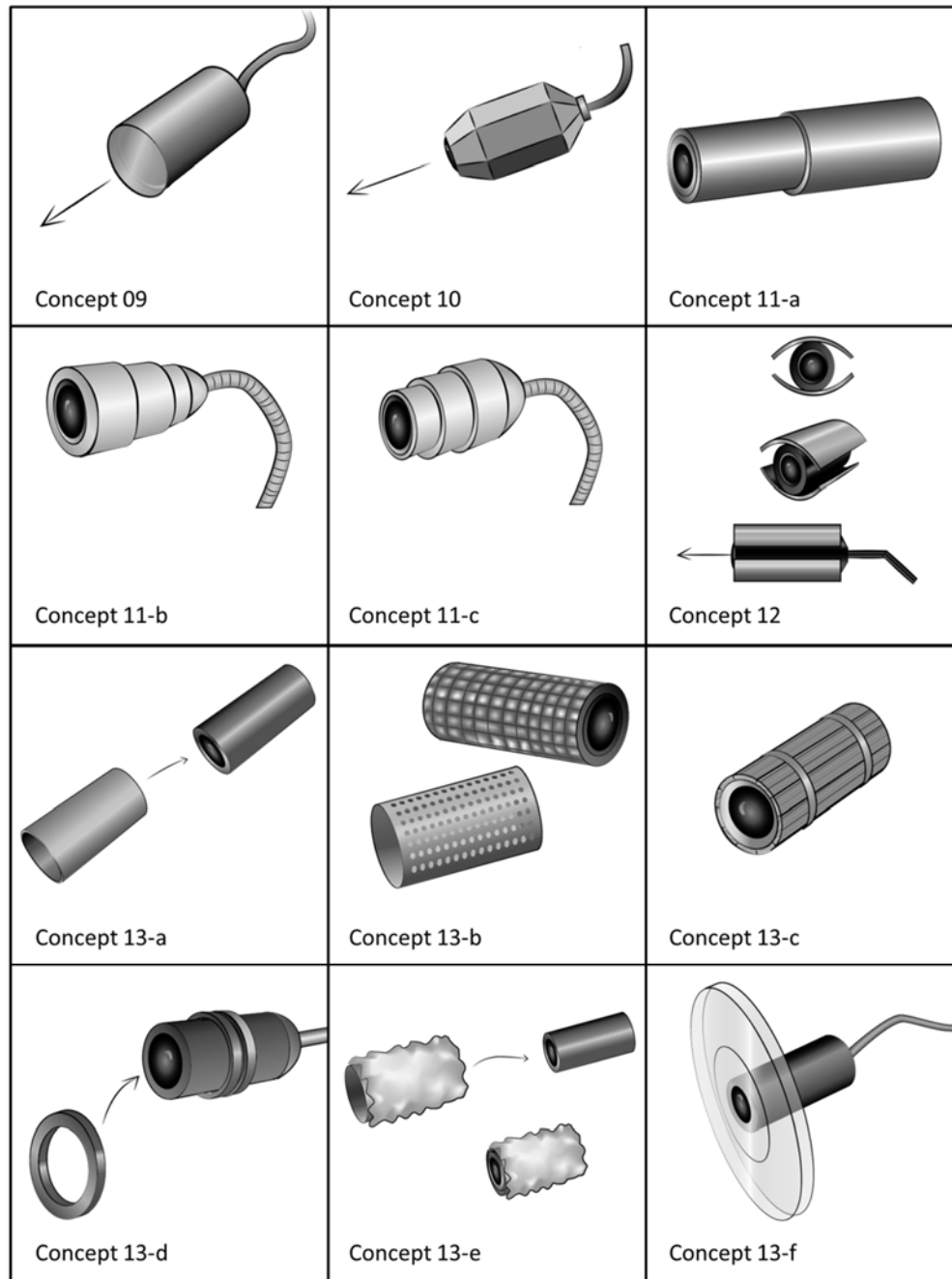

Figure 4.6: Generated concepts.

09: Tinted glass in front of lens. 10: Cylinder camera with bevelled surfaces. 11: Telescope.
 12: Oblong camera with eye shaped profile. 13: Cylinder camera with replaceable skins.

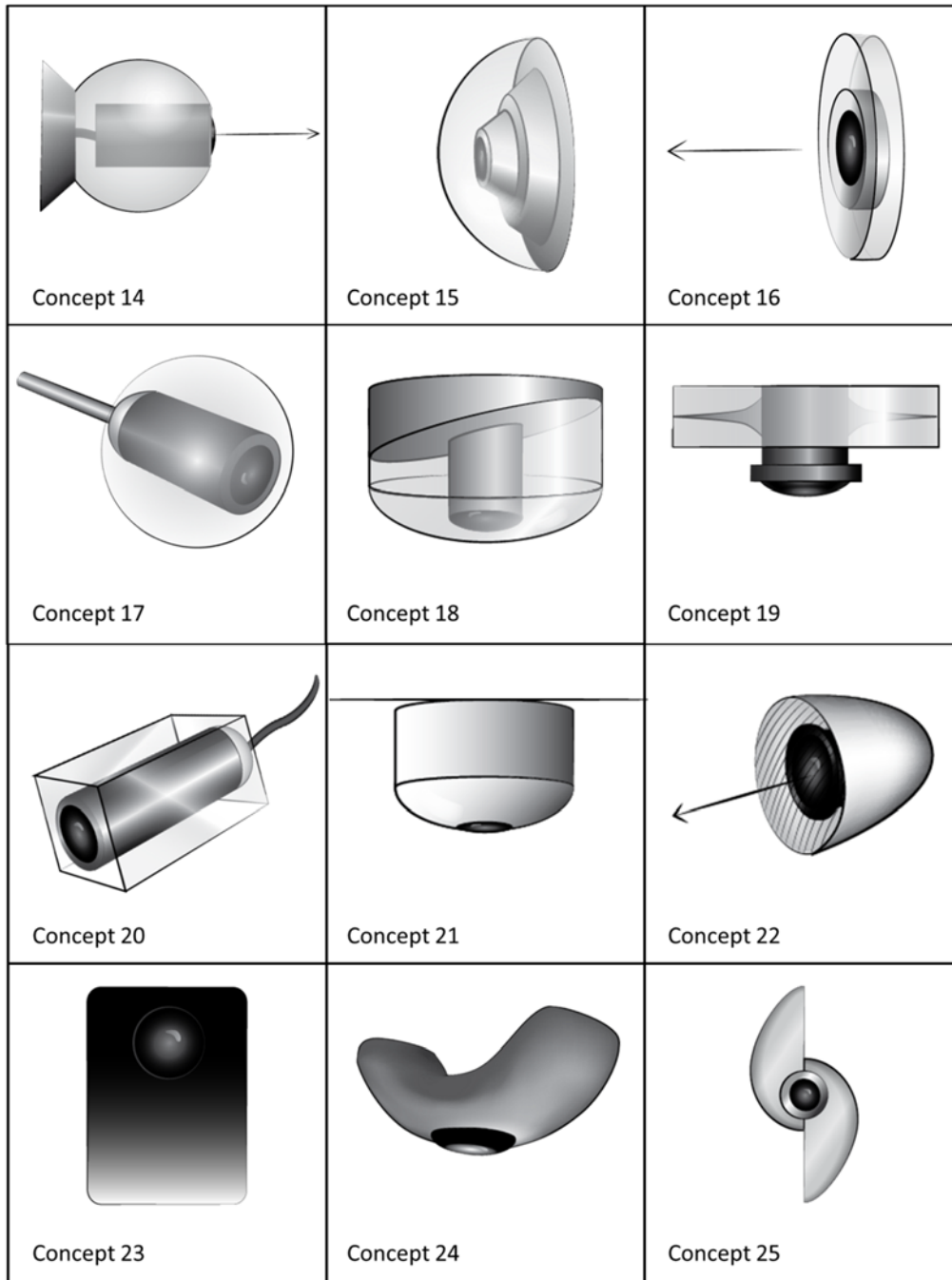

Figure 4.7: Generated concepts.

14 - 20: Cameras with variations of transparent covers. 21: Short cylinder. 22: "Bicycle lamp".
23: Gradient cover, transparent to opaque. 24 - 25: Shape variations.



Figure 4.8: Generated concepts.
 26 – 34: Shape variations. 35: Camera with background light - “halo”.
 36 – 37: Shape variations.

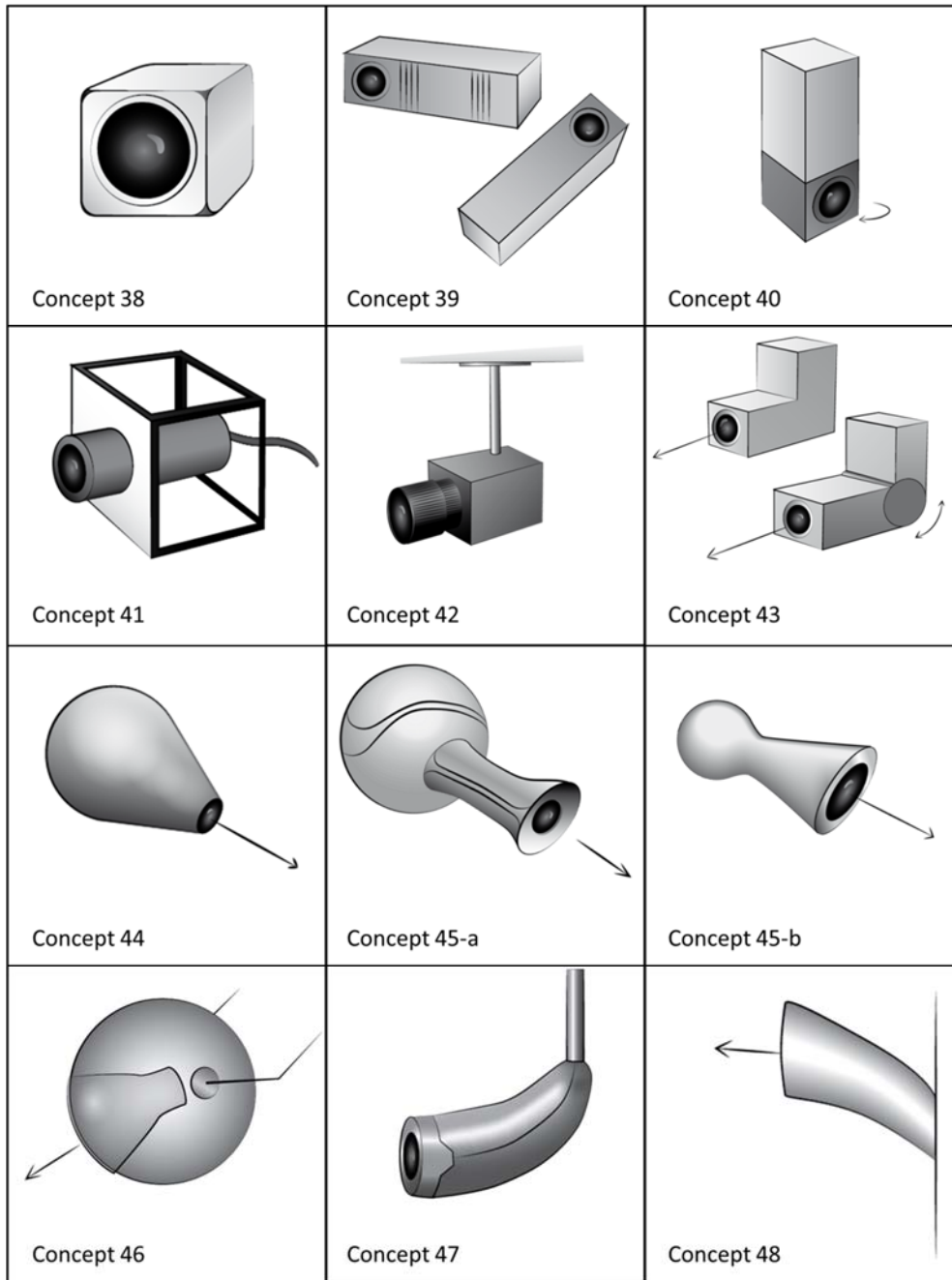

Figure 4.9: Generated concepts.

38 – 39: Shape variations. 40: Rectangular shape with rotatable bottom.
 41: Cylinder camera inside square box. 42: “Old look”. 43: Block camera.
 44 – 45: Shape variations. 46: Sphere camera with visor. 47 – 48: Shape variations.

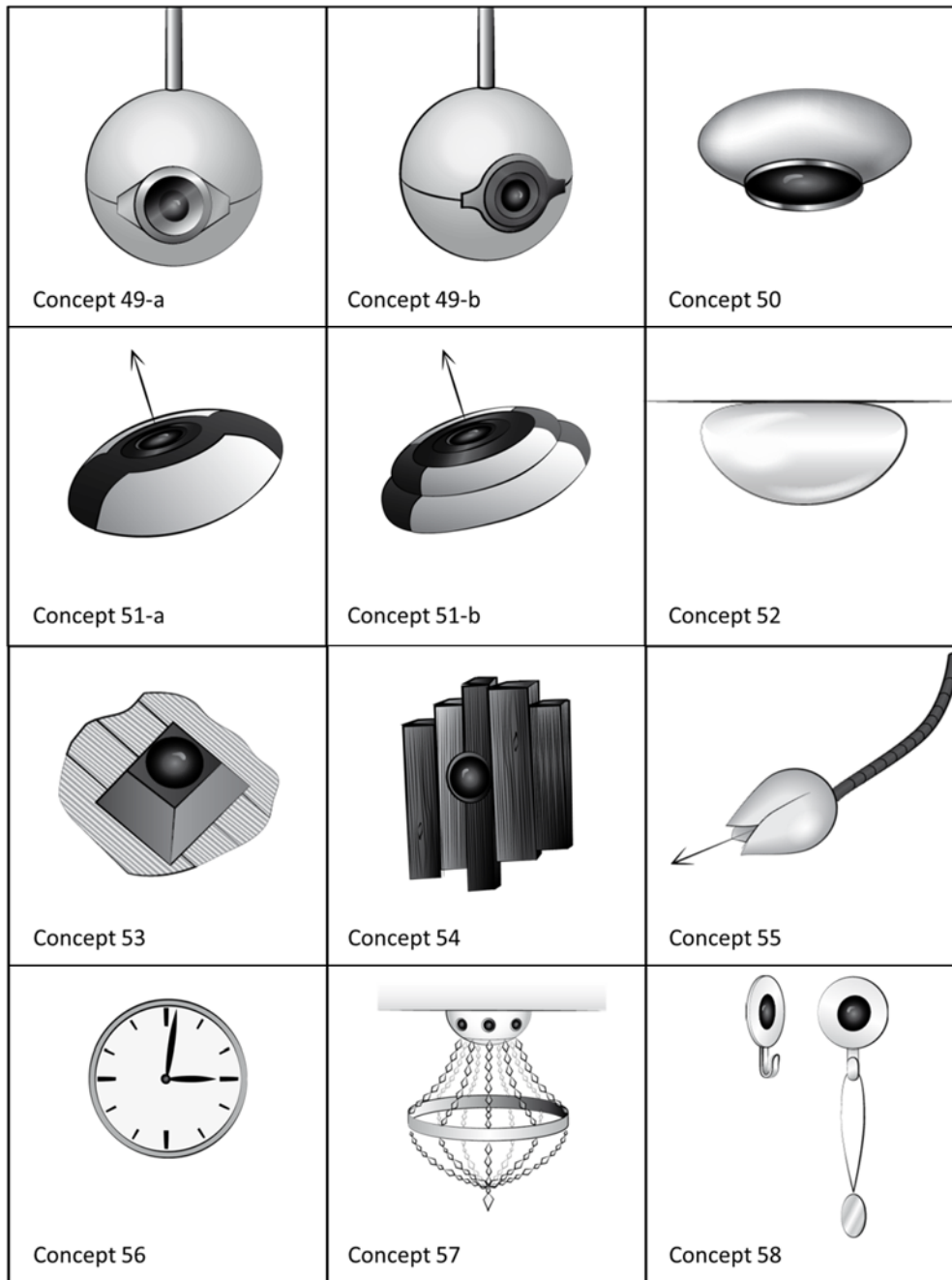

Figure 4.10: Generated concepts.

49 – 50: Shape variations. 51: Two coloured cover. 52: Water drop shape, transparent.
 53: Recessed in ceiling. 54: Wood panel cover. 55: Flower bud on “gooseneck”.
 56: Hidden in clock. 57: Hidden in lamp. 58: Wall hook.

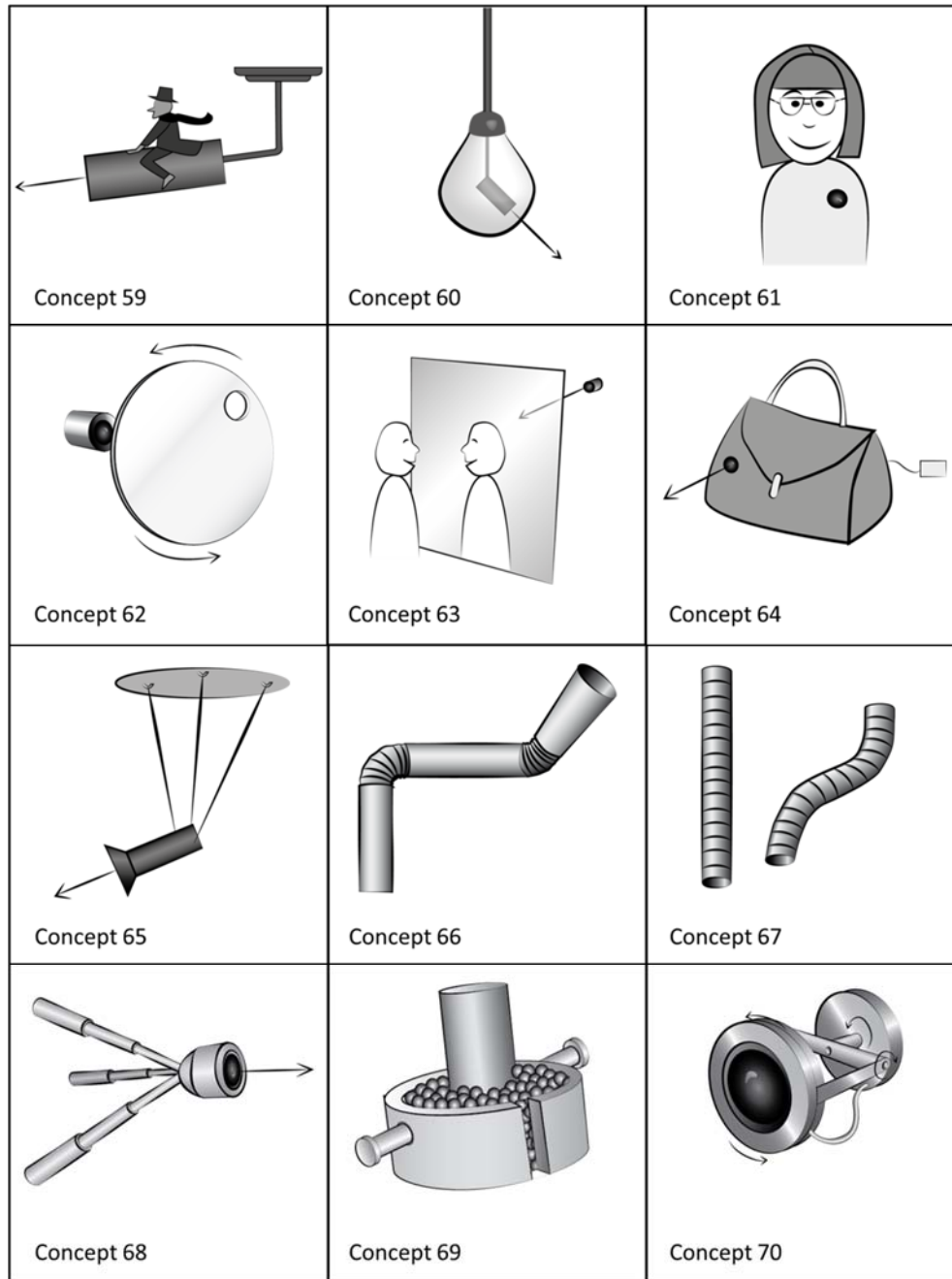

Figure 4.11: Generated concepts.

- 59: Camera with distracting object. 60: Inside bulb. 61: On shop assistant, on mannequin.
 62: Behind rotating disc with hole, angular velocity matched with snapshot frequency.
 63: Behind mirror. 64: Hidden in product. 65: Adjustable wires. 66: Joints like bendable straw.
 67: "Gooseneck". 68: Telescope arms. 69: Stabilisation solution. 70: Combined fork joint.

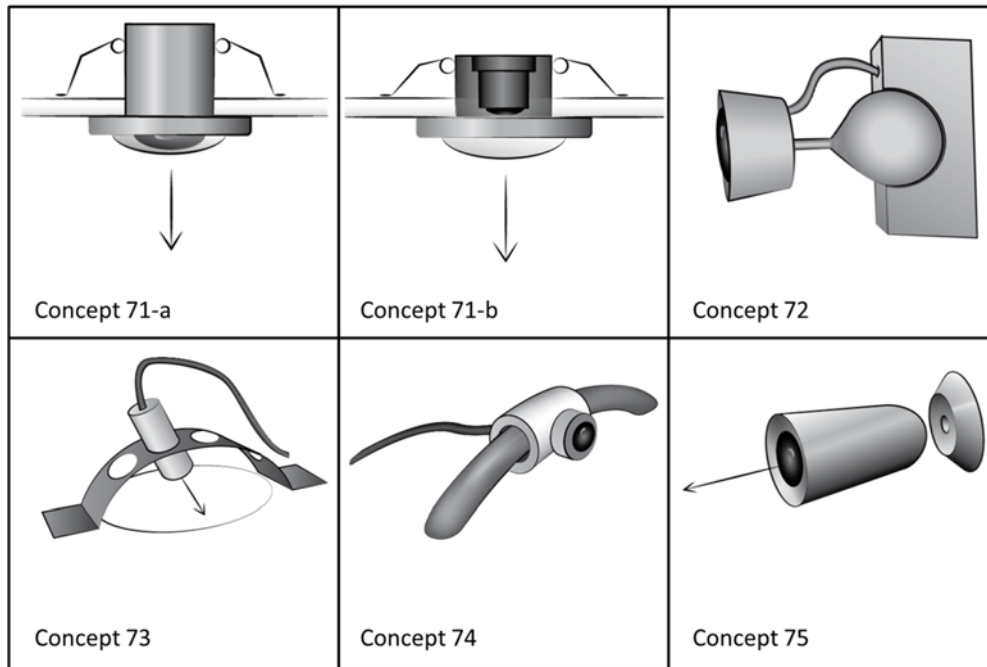

Figure 4.12: Generated concepts.

71: Recessed mounting with flexible springs. 72: Ball and socket joint with visible cable.
73 – 74: Bracket for recessed mounting. 75: Magnetic ball and socket joint with hole for cable.

Some interesting concepts were further developed and 3D models were made in acrylic plastic and modelling foam to evaluate size and function, see Figure 4.13.



Figure 4.13: Concept models made in modelling foam and acrylic plastic.

4.6 Discussion

The shape study was helpful to gain understanding of the possible size of the product. After evaluating the hand-made models, 3D CAD was a useful tool to quickly change minor variations of the design.

In the beginning of the concept generation phase a lot of mood boards were created to find the most suitable expression for the camera design. Eventually one final mood board was assembled with the agreed design expression. This mood board proved to be very useful later in the project when the aesthetics of the final design were to be determined. When the generated concepts became too diverse it was necessary to look back at earlier joint decisions regarding the design, to find the common path again.

This chapter presented a large number of concepts generated throughout the pre-study and concept generation phase. In parallel with creating new ideas, older concepts were revised and improved. The mixture of technological and aesthetical concepts was a result of the diverse sources of inspiration. It was concluded that a separation of the two concept branches would be unnecessary; that a mixture could facilitate the creative process and allow combinations of different ideas.

5 Concept Selection

In this chapter all phases in selecting concepts, to get to the final concept, will be presented.

In this project concept screening and concept scoring was performed in parallel with discussions within a group consisting of people involved in the project. Since the main task of the project was to create a suggestion for a new camera design, with focus on appearance, it seemed deficient to use only the method of decision matrices.

The selection of concepts was performed as an iterative process where a couple of concepts were chosen and refined or in some cases combined, and then re-evaluated.

Throughout the concept selection the features listed below were the most desired:

- An ability to easily hide the cable
- A possibility to customise the function and/or the appearance
- Low visibility

After the first selection presented in chapter 5.1, an Italian luxury retail company was consulted to provide feedback and evaluate the concepts and ideas. The results from this meeting will be presented in chapter 5.2, followed by tests and evaluations of the most interesting ideas.

5.1 First Selection

A first selection from the large amount of generated concepts, presented in chapter 4.5, was done together with the project supervisors at the PCNI department at Axis and then together with other Axis employees; Morten Bergström, Design Consultant and Daniel Åhman, Design Lead. These selections were made as an oral form of concept screening, with the objectives from the function analysis in mind. The selected concepts are presented in Figure 5.1 - Figure 5.7.



Figure 5.1: Concept 03, corner camera.

The idea behind the corner camera was that it would be a discreet camera, casting no shadows on walls or ceilings. It would also provide a good overview of a room due to its placement.

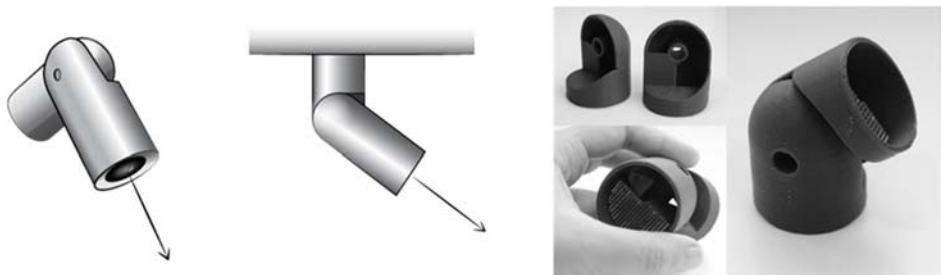

Figure 5.2: Concept 06, adjustable joint camera and Axis' original joint, 3D printed.

The adjustable joint developed in another project at Axis was slightly modified and used as a mounting idea for the camera. This joint hides the cable in all positions.

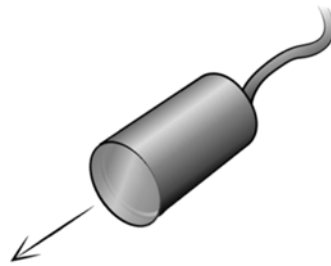

Figure 5.3: Concept 09, lens cover.

This concept shows the idea of covering the lens to minimise the “camera-look”. The suggested cover possibilities were protective mirror film for smartphones, hole-patterned plastic film or tinted glass.



Figure 5.4: Concept 13, cylinder camera with exchangeable skins.

The idea of making the camera customisable with exchangeable skins or gadgets was further investigated in combination with a cylinder-shaped camera base.

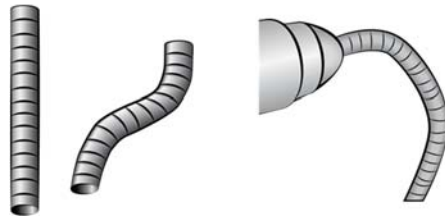

Figure 5.5: Concept 67, “gooseneck”.

The “gooseneck” is a flexible arm that would allow a camera to be easily adjusted and at the same time hide the cable. This concept was generated during one of the brainstorm sessions.



Figure 5.6: Concept 71, recessed camera with springs holding the mounting bracket. The recessed mounting solution is inspired by the AXIS M3011/M3014 camera, mentioned in chapter 4.5. The camera is partially hidden and can be very discreet.



Figure 5.7: Concept 75, magnetic ball and socket joint.
The magnetic ball and socket joint was one of the selected concepts due to its slenderness, ease of installation and its ability to conceal the cable.

5.2 Meeting with Italian Luxury Retailer

A meeting with a group of people, working with loss prevention at an Italian fashion company, was attended to show the ideas and early models. It was concluded that more or less invisible cameras were preferred. Two different mounting concepts were shown, one with a fixed installation and one adjustable. The fixed camera raised discussions about new installation options for other cameras, to hide the camera casing behind the ceiling, with only the outer lens and lens cover showing. This was interpreted as a request for hidden or invisible cameras.

It was said that every store of the Italian fashion company has its own personality and expression, which was interpreted as a desire for a customisable solution.

The “gooseneck” was also given positive attention for its slenderness and ability to hide the cable. Hence, a solution hiding the cable was assumed to be desirable.

The interpreted requirements of a surveillance camera:

- Hidden or invisible camera
- Customisable look
- Hidden cable

5.3 Concept Testing and Evaluation

The remaining concepts, after the first selection and the meeting with the Italian luxury retailer, were tested and evaluated before a concept scoring was made. The tests were mainly focused on the design objectives in the function analysis, with the mood board for the aesthetical appearance in mind. Low fidelity models were made for each concept to better understand how their features would work in reality. The aesthetical ideas of a lens cover and exchangeable skins were thought to be extra features for the other remaining concepts, and were therefore treated as such. The tests will be presented in order of appearance in chapter 5.1; First Selection, but with the ideas of skins applied on the different concepts.

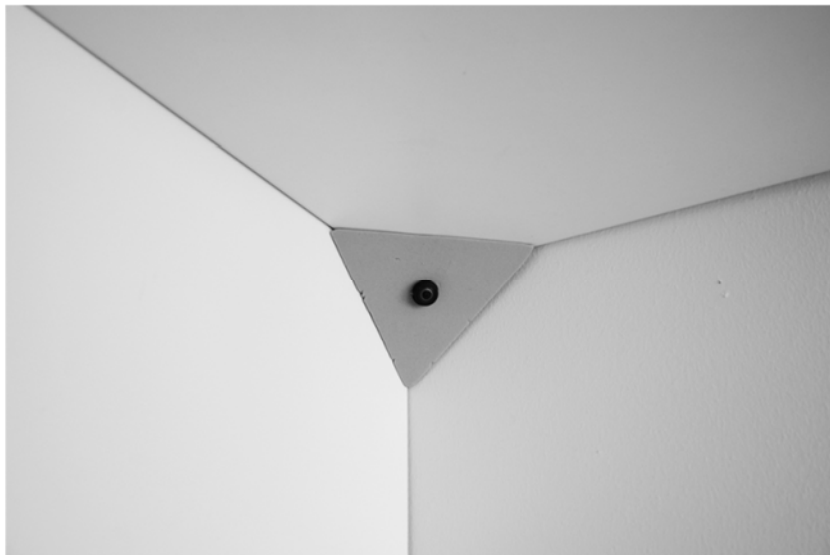

Figure 5.8: Low fidelity model of the corner camera made with modelling foam.
In this picture the model is placed in a corner to investigate its potential.

The corner camera, shown in Figure 5.8, had the disadvantage of few placement possibilities. It was designed to be very discreet and to melt in to the adjacent wall and ceiling surfaces, without casting any shadows. This design would require the corners to be perpendicular for a perfect fit. Perfectly perpendicular corners are rare in reality, which made the design less practical than expected. Another disadvantage of the corner camera was its fixed camera angle.

The limitations of the corner camera design were weighed against its positive aspects of being very discreet. This concept could beneficially be combined with the idea of a lens cover and/or exchangeable skins to naturally blend in with the intended environment.



Figure 5.9: Wall mounted cylinder shaped camera with an adjustable joint.



Figure 5.10: Variations of skins made for the cylinder shaped camera with an adjustable joint.

A cylinder shaped camera was suitable to meet the criterion of customisation possibilities. A circular cross section enabled external manufacturing of skins by lathing, and made it easy to create skins with perfect fit. Figure 5.9 shows a model of the adjustable joint camera made of acrylic plastic and Figure 5.10 presents different skins made to fit the camera.

The geometry of the joint made full cover skins complicated to manufacture, but the joint's ability to hide the cable and redirect the camera was considered more important. Partially covering skins were then investigated but later excluded from the adjustable joint concept due to the unsatisfactory result. The only acceptable solution for customisation of the adjustable joint would be to provide a number of pre-coloured options, or enable easy detachment of the separate parts to facilitate spray-colouring for the customers.

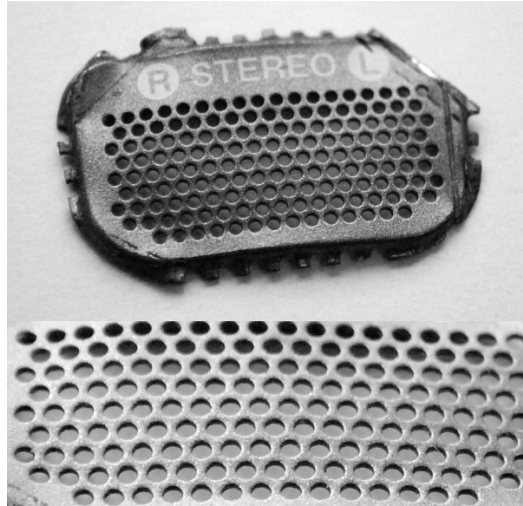

Figure 5.11: Hole-patterned metal piece used for testing the possibility of a lens cover.

The concept of a lens cover generated interest from the supervisors and needed testing to evaluate the potential of the idea. A hole-patterned metal piece, shown in Figure 5.11, was one of the covers used to test the impact on the image quality. The test result with a wide-angle lens can be viewed in Figure 5.12.

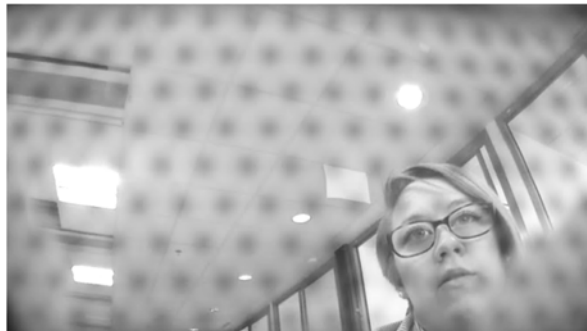

Figure 5.12: Test with wide-angle lens, covered by hole-patterned metal piece.

It was impossible to eliminate the pattern in the picture taken with a wide-angle lens. Using a telephoto-lens, or just a lens with a narrower angle of view, a hole-pattern could be used successfully. The only impact of the pattern would then be a darkened image due to the reduced light transmission. In this project a wide-angle lens was preferred to provide overview, therefore the idea of a lens cover was excluded since the image quality with the wide-angle lenses was too poor.



Figure 5.13: “Gooseneck” with lens.

A “gooseneck” was tested to evaluate the possible stability and required diameter of the joint to make room for a cable. This was one of the concepts that were possible to combine with customisable skins. The necessary diameter of the “gooseneck” made it difficult to adjust and hard to fixate in a certain direction. A thinner “gooseneck” was also tested, with better results, but still not completely satisfying regarding stability.



Figure 5.14: Recessed mounting.

The half-hidden camera was intended for ceiling or wall mounting. This required a possibility to hide the main part of the camera behind a wall or ceiling. Compared to the larger dome cameras this solution would be less visible and steal less attention from the interior design.

The idea was tested by cutting a hole in a piece of cardboard and mounting a cylinder shaped camera model. Drilling a hole for the camera in a wall would inevitably create rough edges which must be covered, see the right image in Figure 5.14. This led to discussions about different ways of covering the edges surrounding the camera. One suggestion is presented in the right side of Figure 5.14.

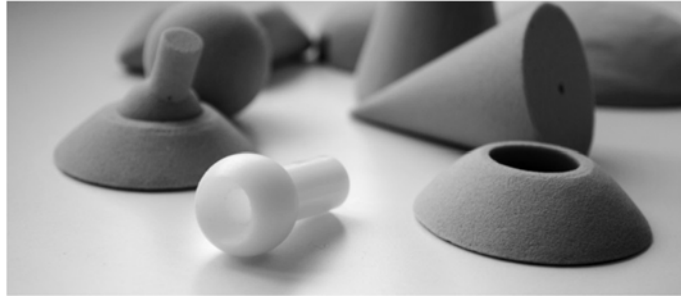

Figure 5.15: Models of the magnetic ball and socket joint.



Figure 5.16: Magnetic ball and socket joint.

The magnetic ball and socket joint was tested with models made in a workshop to investigate the possible size and feasibility of the idea, see Figure 5.15. The magnetic ball and socket joint would require a lot of space because of the intention of leading the cable through the joint. A minimum field of view of 100 degrees was specified for the camera lens. This would require a possibility to tilt the camera plus minus 40 degrees to cover 180 degrees. To fulfil this requirement, the dimensions of the ball and socket joint with a through-going cable needed to exceed an acceptable size limit.

Another idea was to lead the cable outside the joint, but after the meeting with the Italian luxury retailer, see Chapter 5.2, the conclusion was that a hidden cable was preferred, and the idea of a visible cable was excluded.

Magnets were ordered to test the combination of a steel ball and a strong magnet, see Figure 5.16. A disadvantage of the magnetic joint was that the torsional resistance varied in different directions and it would therefore be necessary with additional stabilisation to keep the camera in fixed position.

5.4 Concept Scoring

A concept scoring was performed to select which of the concepts to continue developing. The lens cover and the customisable skins were excluded from the concept scoring since these concepts could be seen as potential additional features for some of the other concepts. All the selection criteria in the concept scoring matrix can be found in the earlier presented function analysis. The criteria that were obviously fulfilled by all the concepts, or feasible to implement, were excluded from the scoring. The scoring matrix can be viewed in Appendix G.

5.5 Results and Discussion after Concept Selection

The result from the concept scoring, presented in order of highest rank, was:

1. Recessed mounting
2. Adjustable joint
3. Corner camera
4. Gooseneck
5. Magnetic ball and socket joint

The two concepts with the highest scores, *recessed mounting* and *adjustable joint*, were chosen. As previously mentioned, a combination of two or more concepts might be preferable. After the results from the concept scoring it was discussed whether the two winning concepts could be combined into one.

During the concept selection many different aspects were discussed, such as manufacturing possibilities, allowed cost, appearance, necessary functions and requirements of the target group.

Since a customisable camera would be an interesting solution in order to satisfy a large number of customers, different colours and materials were considered. In the end the conclusion was that a sleek and minimalist camera design would be most successful, since a large amount of options would be too costly to provide. Instead a modular solution, with a sleek and minimalist design, was explored.

To attain a versatile product to offer the customers, the recessed and the adjustable camera were combined into a modular system where a camera unit could be placed in either a fixed recessed casing or a sleek adjustable cylinder shaped casing. This solution satisfied the requirement of providing overview and a customisable appearance.

To explain the thought behind this modular system a “matrix of modularity” was assembled, see Figure 5.17. The matrix shows the combination possibilities of the selected concepts. Two different camera units, or “base units”, were created with equal outer dimensions to fit both the adjustable and the recessed casing. By providing base units with different lenses the versatility of the camera would be further improved. For both casings the cable was assumed to be hidden in the wall or ceiling.

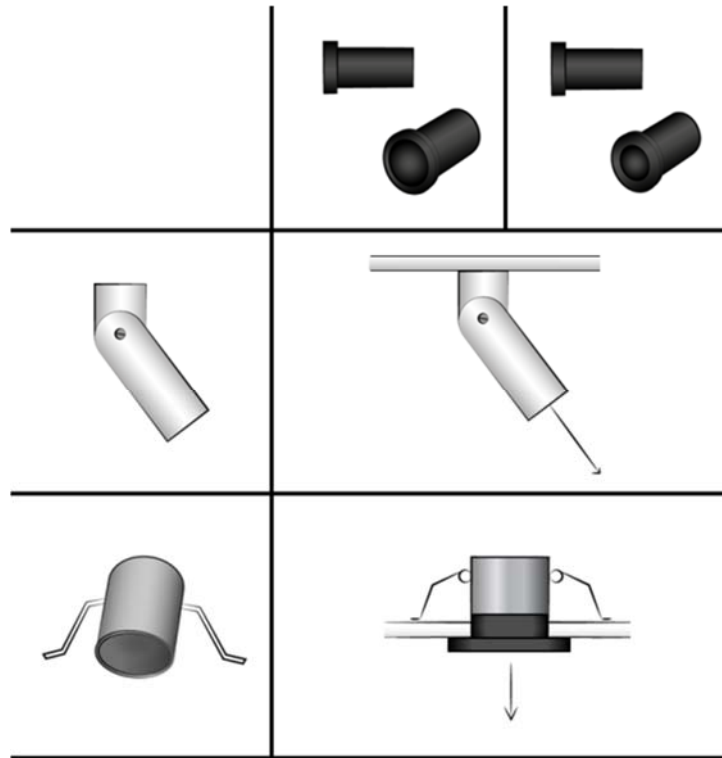

Figure 5.17: Matrix of modularity, showing the possible combinations of the different camera units and casings.

The idea of offering two camera designs in one was given positive response from the people involved in the project. This modular solution was chosen for further development, and the other concepts were excluded.

6 Concept Refinement

This chapter discusses the refinement of the chosen concept; general and detail appearance, mounting options, colour and material.

The selected modular system consisting of an adjustable camera and an option for a fixed recessed mounting was further developed. The included parts in the system were thought to be two base units with equal outer dimensions, one casing for recessed mounting, one adjustable casing and mounting solutions for both designs.

The two base units were to be developed for two different wide-angle lenses, providing options for surveillance overview. The customer could then choose the most suitable base unit and combine it with the preferred casing. The next step was to decide dimensions and design of the components included in the system.

Different diameters for the cylinder shape of the adjustable camera were evaluated and tested with different types of cables to find the best compromise between a sleek outer look and enough space for a cable and base unit. An aesthetically appealing proportion between the diameter of the lens and the diameter of the circular front side of the base unit was pursued. Since one of the chosen lenses had a smaller diameter it was discussed whether an extra circular shape in the front of the base unit could make the lens look bigger and more similar to the larger lens. The diameter of the base units also needed to suit both the design of the adjustable and the recessed casing.

3D-printed models were evaluated and a final outer diameter of 28 mm was stated as preferable for the frontal part of the base unit and the adjustable camera casing. This was considered a suitable dimension with a wall thickness of the casing that allowed hidden fastening devices for the base unit. Since the base units should fit both casings the size of the recessed casing became dependent on the other components. The reason for determining the size of the adjustable casing and the base units first, was that these parts were considered more sensitive regarding the proportions and space for necessary components.

The first 3D printed models of the base units and the adjustable joint can be viewed in Figure 6.1, where the base unit is mounted directly into a card board to get an understanding of required size for a mounting solution behind the wall.



Figure 6.1: 3D-printed models of the base units and the adjustable joint.

6.1 Detail Refinement

The fine details, proportions and visibility of the base unit's upper edge were evaluated. Figure 6.2 shows variations of the top of the base unit from the side and from above. Grooves on the side for adjusting the image's horizontal plane and grooves on the top to mark the horizontal line were tested.

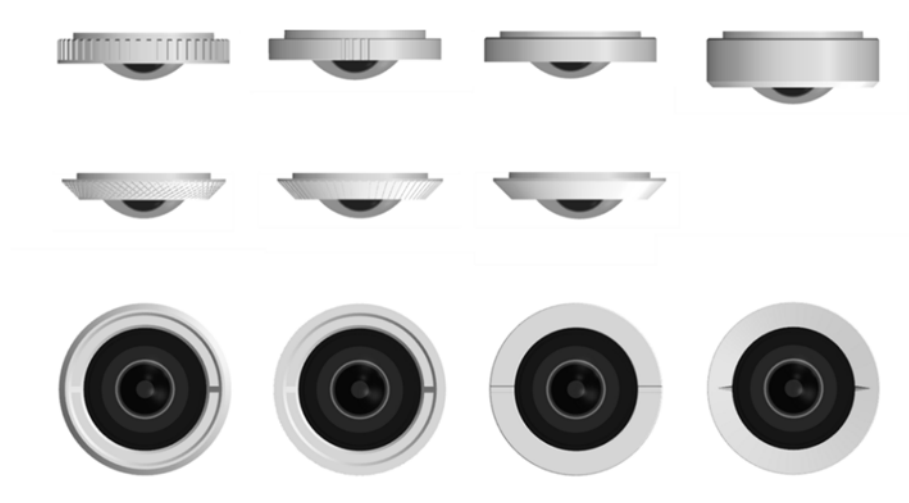

Figure 6.2: Variations of the top of the base unit.

3D printed models were made to evaluate the shape and appearance of the base unit. Figure 6.3 shows the first models of the base unit with grooves on the top side.

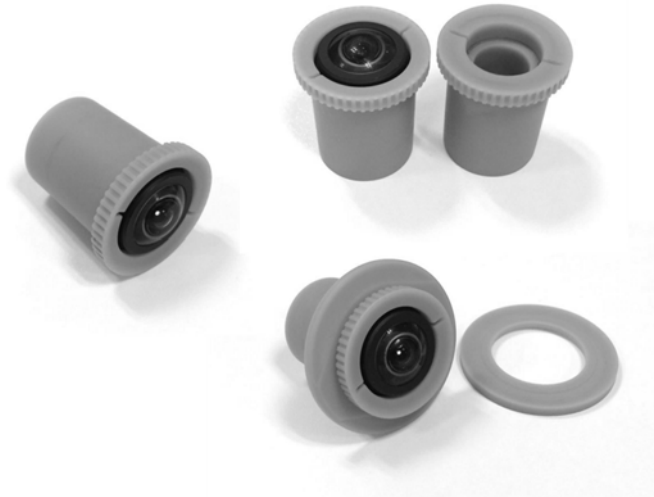

Figure 6.3: 3D printed models of the base unit and cover plate.

The adjustable camera, originally cylinder-shaped, was given a number of different shape features, using 3D-CAD, to find the most suitable appearance; see Figure 6.4. Lines were extruded to shorten the look and the sides were flattened to define the shape.

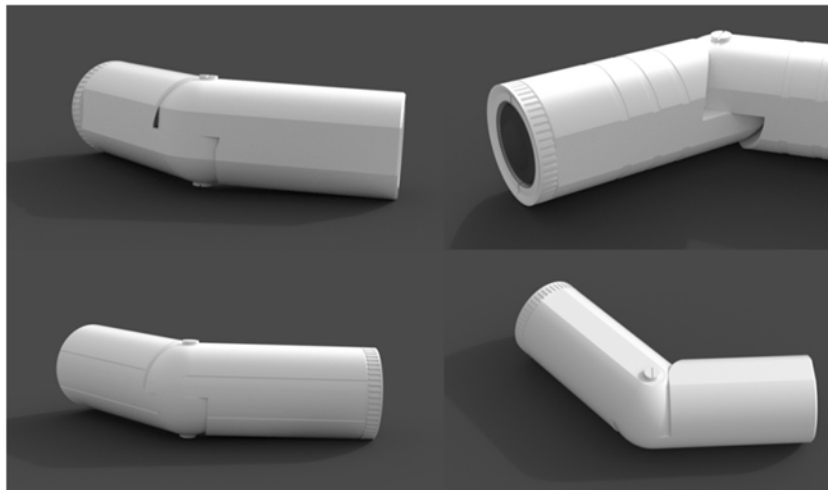

Figure 6.4: Rendered pictures of shape variation features on the adjustable joint.

For the adjustable camera a clean cylinder shape matched the intended environment more than the other options. The tightening screw on the side was recessed to enhance

the cylinder shape, in contrary to the presented pictures in Figure 6.4. To find suitable proportions between the two parts of the adjustable joint, 3D printed models were made; see Figure 6.5.



Figure 6.5: 3D printed models of the adjustable camera, containing the base unit on the left and detached on the right.

For the recessed camera, a cover plate was needed to hide potential uneven edges from drilling in the wall or ceiling. Different models were made and can be viewed in Figure 6.6.

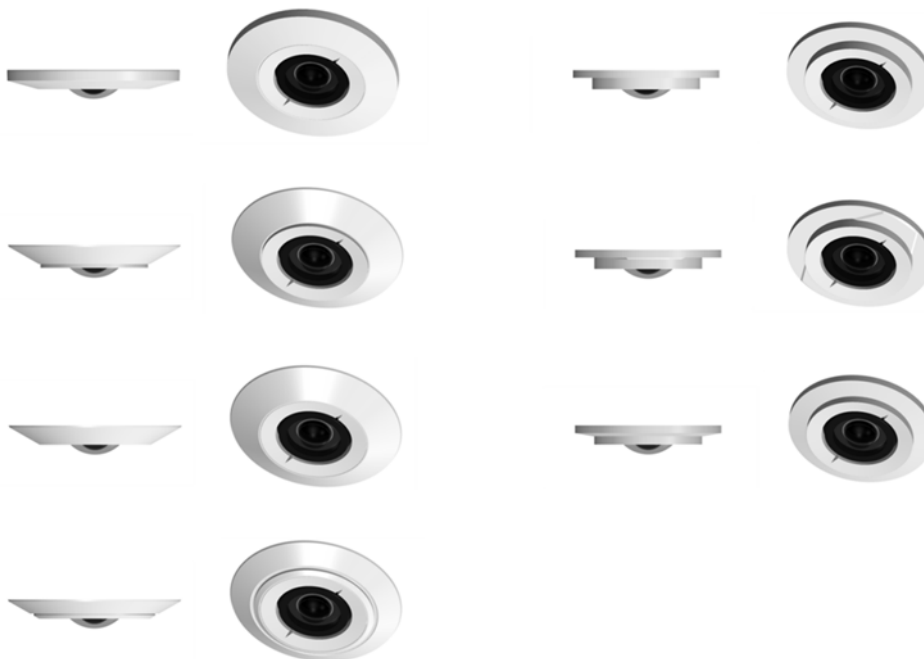

Figure 6.6: Cover plate variations for the recessed camera made with 3D-CAD.

The shape of the cover plate needed to be elegant but not too simple. A conical shape was evaluated and compared with a more strict design consisting of two discs in different levels; see Figure 6.6.

6.2 Colour and Material Selection

A colour map was used to find the exact colour shades. The glossiness of the colours was investigated to find out how ceiling mounted objects appear depending on the degree of glossiness. Most ceilings have a colour without glossiness and therefore it is preferable if the objects have a similar matte colour.

A number of different materials were considered for the chosen camera designs. The most frequently mentioned materials were plastics or metals. The complexity of the construction, and the requirement of at least two different colours, led to thoughts of injection moulded plastics. An important criterion was for the plastic to look exclusive. Thus, the surface structure was considered to be very important for the final design. The AXIS P12 sensor units are currently manufactured in aluminium and then coated with a black colour, which provides the surface with a moderate shine. A similar look could be interesting in combination with a matte plastic surface.

Figure 6.7 shows a variation of surface roughness and colour glossiness for the final design of the adjustable camera. Different combinations of surface roughness and glossiness were evaluated. The presented options are shown in rendered close-up pictures in Figure 6.8.

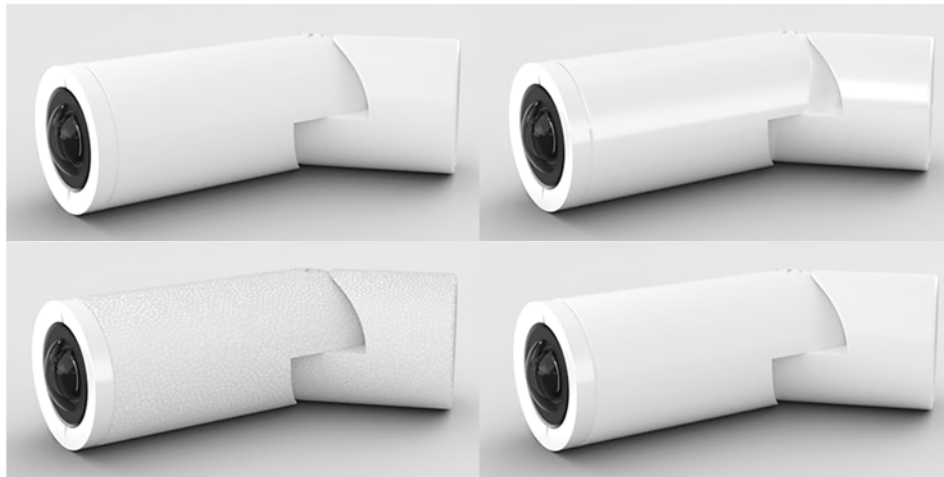

Figure 6.7: Rendered pictures for study of the surface roughness and colour glossiness for the adjustable camera.

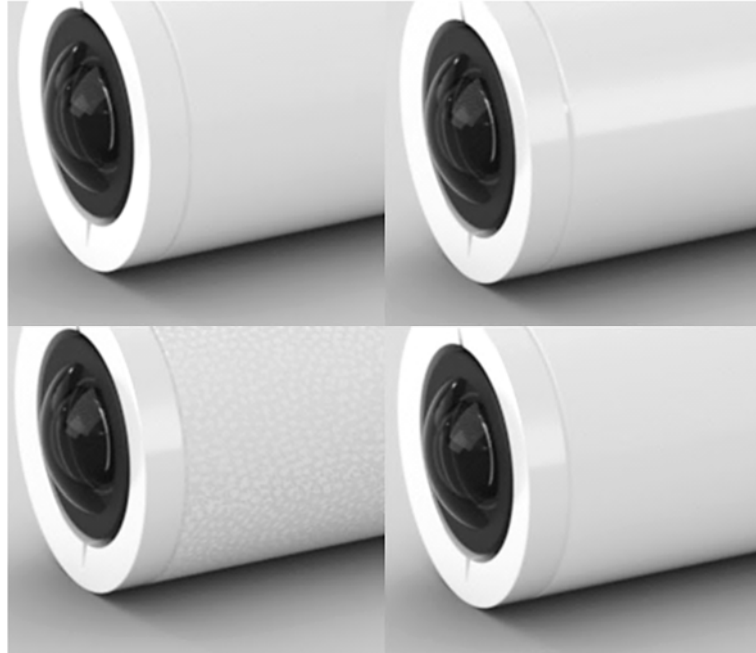

Figure 6.8: Rendered close-ups of the studied surface combinations for the adjustable camera.

The different combinations of surface structures and glossiness were also tested on the parts included in the recessed camera, see Figure 6.9. In Figure 6.10 close-up pictures of the four different combinations are presented.



Figure 6.9: Different surface structures and glossiness of the recessed camera shown in rendered pictures.

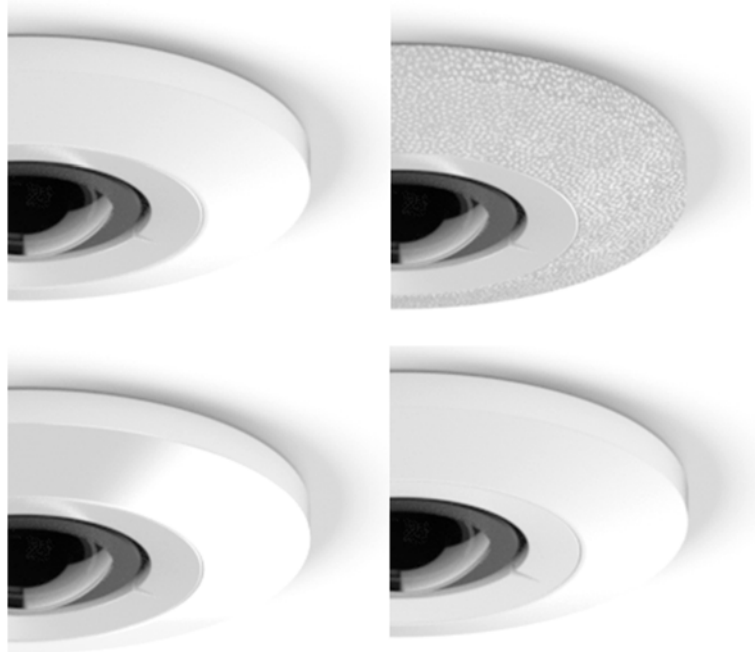

Figure 6.10: Rendered close-ups of surface combinations, recessed camera.

6.3 Mounting Options

A number of different options were investigated for the connections that needed mounting solutions; fastening the base unit to the casings, fastening the casings to a mounting bracket, fastening the mounting bracket to a wall or ceiling and mounting the cover plate.

The attachment between the base units and the casings had the following requirements:

- Enable a 360 degree rotation
- Allow detaching
- Be easy and intuitive
- Make a satisfying click-sound when fastened

The requirements for the mounting brackets:

- Low or no visibility
- Lead the cable through the wall or ceiling
- Ensure that the camera does not fall down from the ceiling or wall

Additional requirements concerning the bracket for the adjustable camera:

- Enable a 360 degree rotation
- Allow image height adjustment

Figure 6.11 shows a selection of mounting suggestions that were investigated for all connections except for the cover plate. It was preferable if the same type of solution could be used in all these connections.

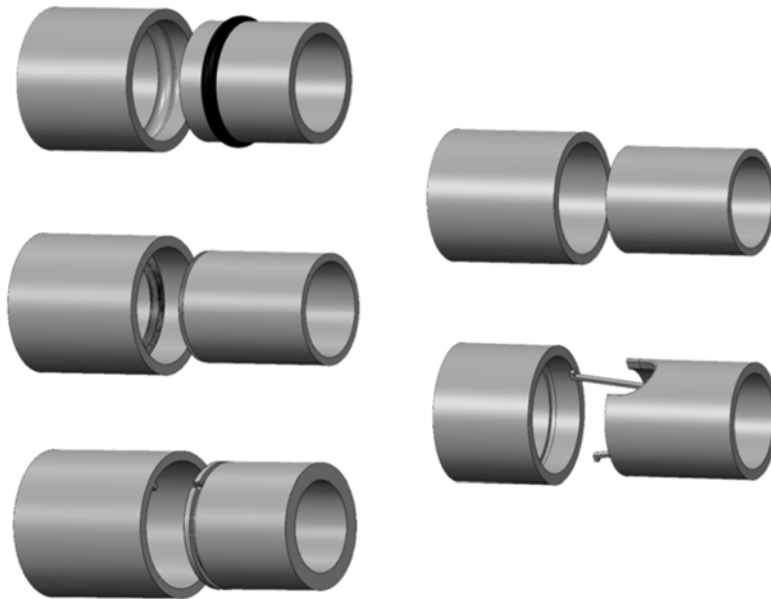

Figure 6.11: Suggestions for mounting connections.
Left column: rubber gasket ring with matching groove / magnets /
a knob that fits into a groove.
Right column: press fit / flexible metal latches.

A simple fastening solution for the cover plate was pursued. The most important criterion was that there should be no visible fastening devices like screws etc. and that the cover plate could easily be detached to enable adjustment of the horizontal plane, by rotating the base unit. An early suggestion was to use hidden magnets that could be attached to the mounting bracket for the recessed camera; a solution that would require the mounting bracket to be made of a ferrous metal.

6.3.1 Mounting Bracket for the Adjustable Camera

A couple of different suggestions for mounting brackets were discussed. Figure 6.12 shows an early suggestion with three flexible arms that snap to a groove inside the upper part of the adjustable camera casing.

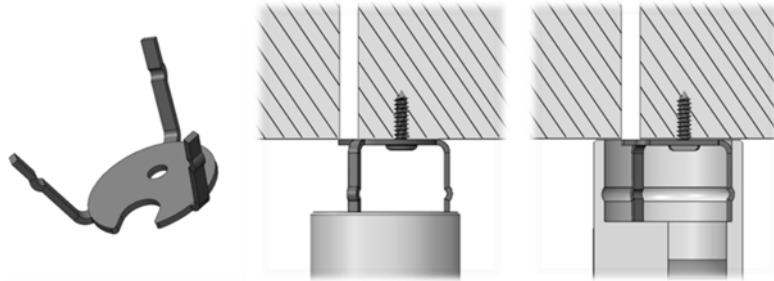

Figure 6.12: Mounting bracket with flexible arms.

The advantage of this solution was its simplicity and easy manufacturing. Though, to be able to fit the part into the camera, the bracket needed to be very small. This forced the screw hole and the hole for the cable too close to each other. A paper model was made to confirm the required size, which proved that two holes could not be drilled into a wall or ceiling that close to each other.

A consultation with Jens Christian Andersen [15] resulted in a new idea for both recessed and surface mounting. The new suggestions for ceiling and wall mounting of the adjustable camera are presented in the figures below, followed by the suggestions for the mounting of the recessed camera, presented in the next subchapter.

The threads in the top are self-tapping, which means that they cut threads in the wall when installed and thereby get a tighter fit to the ceiling or wall. Figure 6.13 shows the first version of the mounting screw, with slots in the front to enable installation with a screwdriver.

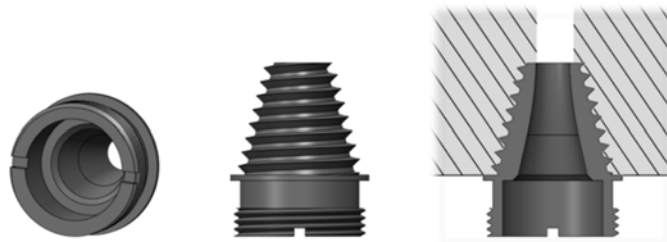

Figure 6.13: Mounting screw 1, for the adjustable camera.
Tapered end with self-tapping threads and a slot for installation with screwdriver.

Another option was to make a Torx screw patterned hole inside the mounting screw, see Figure 6.14. This would improve the steadiness when mounting the screw and enable a grip that reduces the risk of contact between dirty hands and ceiling/wall.



Figure 6.14: Mounting screw 2, for the adjustable camera.
Tapered end with self-tapping threads and a Torx screw
patterned hole for installation with screwdriver.

The tapered end of the screw in Figure 6.13 and Figure 6.14 was thought to facilitate the installation by steering the screw in the right direction. This conical shape was re-evaluated and modified as can be seen in Figure 6.15. In this figure the screw has M20 standardised threads and a small, but still sufficient, taper at the top that leads the screw into the pre-drilled hole.



Figure 6.15: Mounting screw 3, for the adjustable camera.
M20 standardised threads and a Torx screw patterned
hole for installation with screwdriver.

The purpose of the lower threads in Figure 6.13 - Figure 6.15 was to fasten the camera to the mounting screw. In Figure 6.16 the thought function is shown. When the threaded end is screwed into the end of the camera casing it eventually passes the threads, which allows the camera to be turned 360 degrees around its own axis.

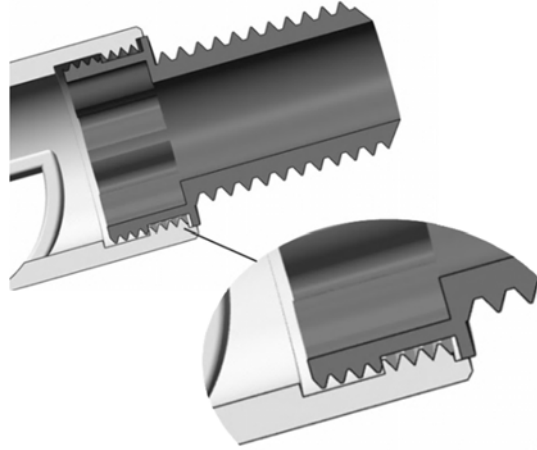

Figure 6.16: Cross-section of the overlapping threads connecting the adjustable camera to the mounting screw.

The negative aspects of the option with threads were that the camera would tilt in relation to the ceiling or wall, and that the friction between the threads and the brim would be hard to control. This resulted in a fourth version, shown in Figure 6.17, where the threads are replaced with a groove for a spring. As previously mentioned it would be preferred if all connections could have the same solution. Figure 6.18 shows the thought solution of a circular buckled spring combined with grooves, here on the outside of the base unit and inside the adjustable joint.

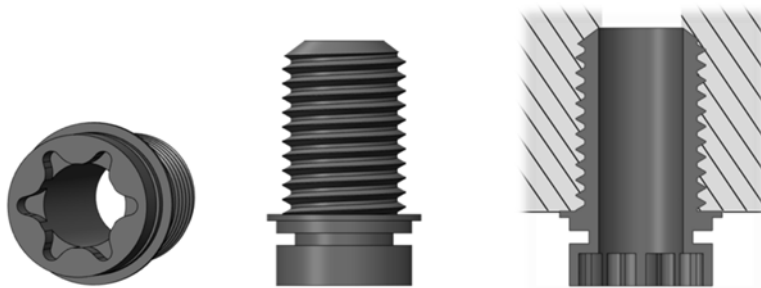

Figure 6.17: Mounting screw 4, for the adjustable camera. M20 standardised threads and a Torx screw patterned hole for installation with screwdriver.
Groove for mounting of camera.

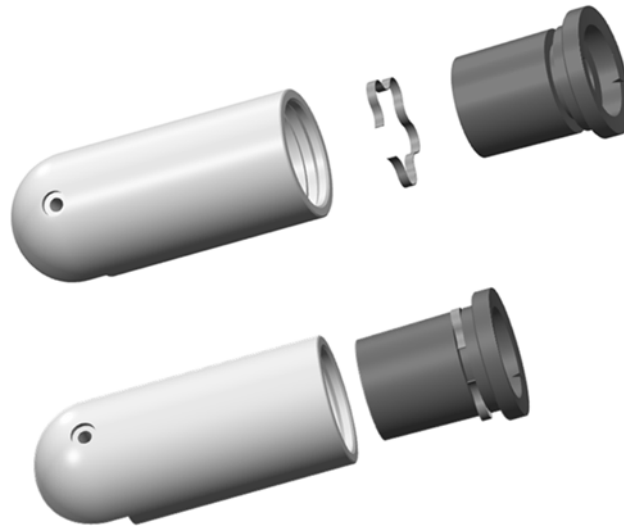

Figure 6.18: Mounting the base unit in the adjustable camera casing with a buckled spring.

A 3D-printed model of the screw for the adjustable camera casing was made to test the feasibility of the idea. This model can be viewed in Figure 6.19.

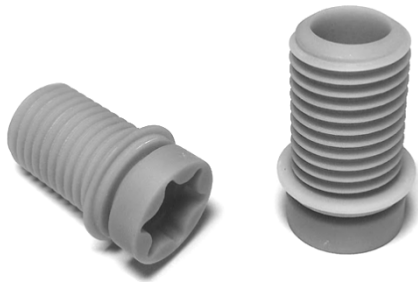

Figure 6.19: The 3D printed mounting screw for the adjustable camera.

6.3.2 Mounting Bracket for Recessed Camera

The recessed camera required a mounting bracket that could contain and fasten the base unit. The mounting bracket needed a fastening solution for the base unit and a mounting solution to fasten the bracket to a wall or ceiling. The same principle with self-tapping threads, as for the adjustable camera, was used.

Figure 6.20 presents the first version of the mounting screw for the recessed camera. This suggestion had slots in the front to enable installation with a regular screwdriver.



Figure 6.20: Mounting bracket 1, for recessed camera. Tapered end with self-tapping threads and a slot for installation with screwdriver.

When further developed, the slots were replaced with a Torx screw patterned hole to allow a better grip and a greater force when installing the mounting screw. Figure 6.21 shows the mounting screw with a Torx screw patterned hole.



Figure 6.21: Mounting bracket 2, for recessed camera. Tapered end with self-tapping threads and a Torx screw patterned hole for installation with screwdriver.

The taper in the back was then shortened, see Figure 6.22, which made more room for the base unit but maintained the steering function. The final version of the mounting screw for the recessed camera is shown in Figure 6.23, where a groove for the circular flower shaped spring was added on the inside.



Figure 6.22: Mounting bracket 3, for recessed camera. M30 standardised threads with a small taper and a Torx screw patterned hole for installation with screwdriver.

In Figure 6.20 - Figure 6.22 the base unit was intended to be fastened by press fit, which was later replaced with the same solution as for fastening the adjustable camera to its mounting screw, with a spring and groove. This would be a safer connection to secure the base unit. The final mounting screw for the recessed camera was 3D-printed and tested with satisfying results; see Figure 6.24.

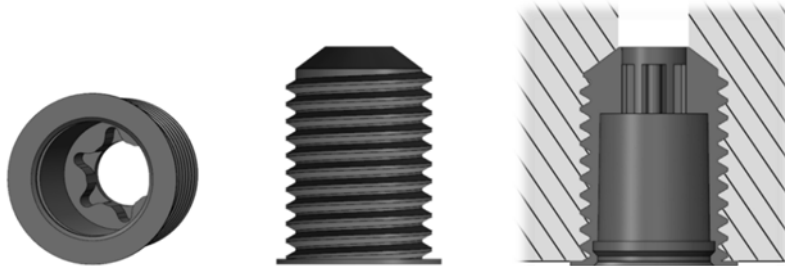

Figure 6.23: Mounting bracket 4, for recessed camera. M30 standardised threads with a small taper and a Torx screw patterned hole for installation with screwdriver. Groove for mounting of base unit.

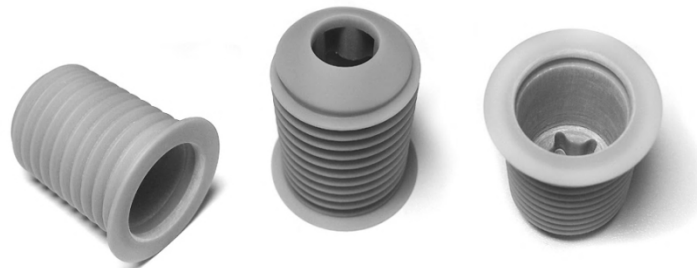

Figure 6.24: The 3D printed mounting screw for the recessed camera.

6.4 Discussion

Since an important criterion for the camera was to blend in with the environment, a matte surface was considered to be the most suitable option. The camera was intended to be sold to high-end stores and needed a design that would appeal to the purchaser. A mainly matte coloured camera with a glossy detail could blend in smoothly with the ceiling or wall when installed, and at the same time be interesting when seen from a short distance.

In the beginning of the project a solution that enabled customised colours and materials was sought. After discussions it was concluded that this idea was hard to realise and that some customers already had their cameras spray-coloured to match the environment. Therefore two colours were prioritised; a white/light colour and a darker one.

A grooved or patterned surface was suitable to make the upper edge of the base unit as intuitive and user-friendly as possible regarding its rotation. Though, the camera would most likely not be re-adjusted more than a couple of times per year, and therefore a discreet appearance without unnecessary details was considered more important. The grooves also gave the design a mechanical appearance which contrasted too much with the intended environment of the camera. Overall it was decided that a sleek and minimalist design was preferred. Depending on future potential customers some kind of grooves might be requested for an improved friction and an intuitive appearance that communicates the possibility of rotation.

The Torx screw patterned hole was chosen for the mounting screws since it allowed a larger torque than a regular screwdriver. Another advantage of the Torx solution was that it reduced the risk of accidentally rubbing dirty hands against the wall; since no other stabilisation than the screwdriver was necessary.

7 Presentation of Final Proposal

This chapter presents the final design proposal.

The final design proposal is a modular system with two mounting options. The camera can be either fixed or adjustable, depending on its purpose. The two different base units, with two types of lenses, fit both the recessed mounted and the adjustable installation. Both designs can be mounted in either ceilings or on walls, depending on desired surveillance.

The modular system is created to suit the customer requests of customisability and at the same time be very discreet when placed in the intended environments. The design proposal is presented in Figure 7.1 - Figure 7.5.



Figure 7.1: 3D-printed models of the final design proposal presented in white.



Figure 7.2: 3D-printed model of the adjustable camera placed in the ceiling.

The adjustable camera can be redirected in three directions. The whole camera can be rotated around its own axis in the connection to the ceiling and with the screw and sleeve nut the height can be adjusted. The lines by the lens, on the base unit, help to find the horizontal plane of the image, which is adjusted by rotating the base unit in the front of the camera. The versatility of the adjustable camera makes it suitable for placement in both ceilings and on walls and makes it easy to cover interesting areas for surveillance. The screw and sleeve nut are recessed and follow the sleek surface of the camera when tightened. The outer diameter of the camera is 28 mm and the total length when straightened is 87 mm.



Figure 7.3: 3D-printed model of the recessed mounted camera placed in the ceiling.

The recessed camera is designed to lie close to a ceiling or wall and be very discreet. The cover plate, that hides potential marks from drilling, can easily be disassembled due to its magnetic mounting solution. When the cover plate is detached the horizontal plane can be adjusted by rotating the base unit around its own axis. The front of the base unit has a slight bevelling and together with the glossy surface it creates a pleasant reflection. With the cover plate the outer diameter of the camera is 45 mm and the height, excluding the raised lens, 5 mm.

7 Presentation of Final Proposal

The modular camera system comes in two colour variations; black and white. Figure 7.4 and Figure 7.5 presents rendered pictures of the four possible design options. The product is thought to be sold in a package containing one recessed and one adjustable casing in either black or white.



Figure 7.4: Rendered pictures of the recessed camera presented in black and white.



Figure 7.5: Rendered pictures of the adjustable camera presented in black and white.

Figure 7.6 shows a picture of the products in an example of their intended environment. In the picture the recessed camera design is placed next to one of today's existing products to compare size and visibility.

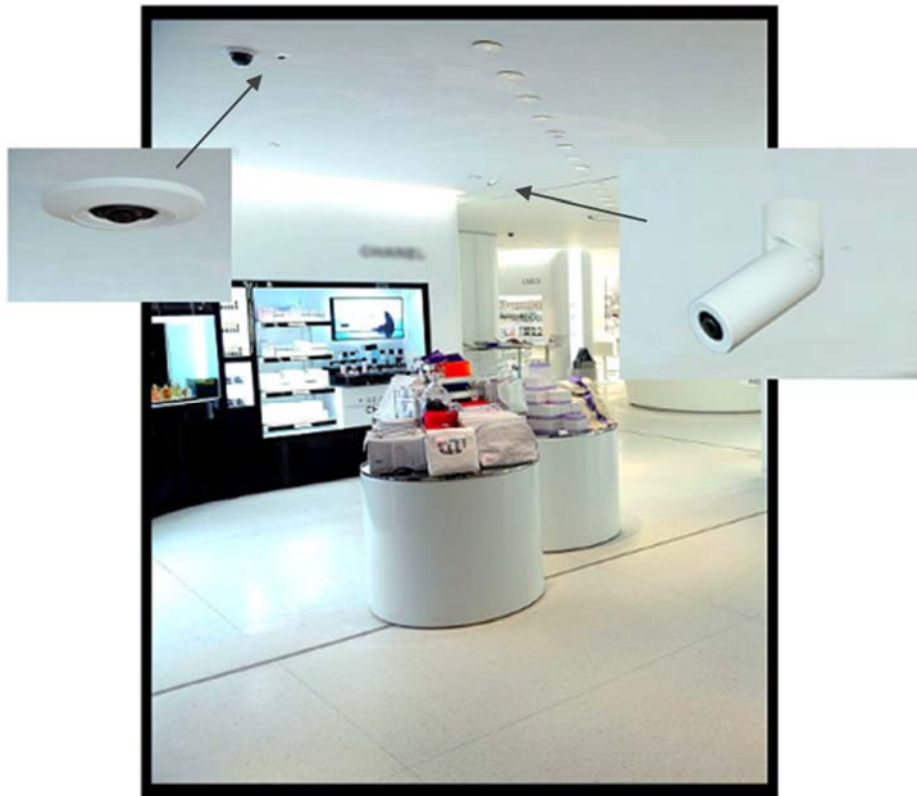

Figure 7.6: Pictures assembled in Photoshop to show the products in an example of their intended environment.

7.1 Mounting

The cameras are designed to be easily installed with two individual mounting screws. Figure 7.7 shows the mounting screw for the recessed installation. The mounting screw has a through-going hole for the cable and is designed to contain and hold the base unit. It has a Torx screw patterned hole that enables a quick and easy installation, which also minimises the risk of soiling the wall since no contact between hand and wall is necessary.

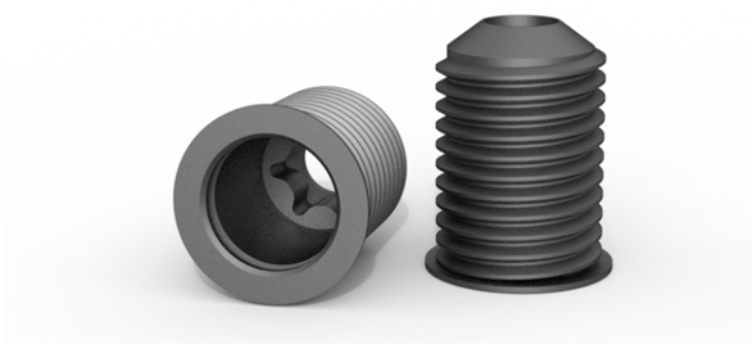

Figure 7.7: Mounting screw for the recessed camera.

Figure 7.8 shows the mounting screw for the adjustable joint. This mounting screw also has a Torx screw patterned hole, which simplifies the installation. Both screws allow the cameras to be fastened tightly to the wall, with no visible mounting brackets. Their self-tapping threads create a snug fit to the wall.

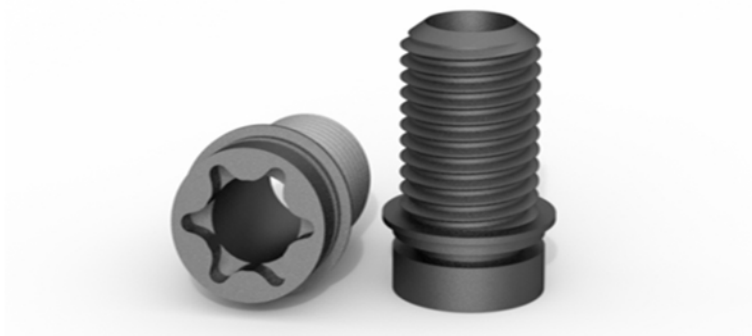

Figure 7.8: Mounting screw for the adjustable camera.

The mounting screws have edges that prevent the screws from being drawn into the wall/ceiling when mounted. The edge on the mounting screw for the recessed camera is wider to make room for the necessary magnetic surface to fasten the cover plate.

The single grooves on the two mounting screws allow fastening of the adjustable camera casing or base units with a buckled spring. The buckled spring in combination with grooves, used for connecting the different components, has not been tested and could be further developed to ensure a satisfying click sound and stabilisation when connected.

On the mounting screw for the adjustable camera the groove is on the outside and on the mounting screw for the recessed camera it is placed on the inside. Figure 7.9 shows how the base unit is fastened to the longer frontal part of the adjustable joint. It is the same solution as for the mounting screws.



Figure 7.9: Mounting of the base unit in the adjustable camera with a buckled spring.

Figure 7.10 and Figure 7.11 shows the mounting of the cameras in simplified pictures made in Creo Parametric. On the back side of the cover plate there are two holes for magnets that attach the cover plate to the edge of the mounting screw.

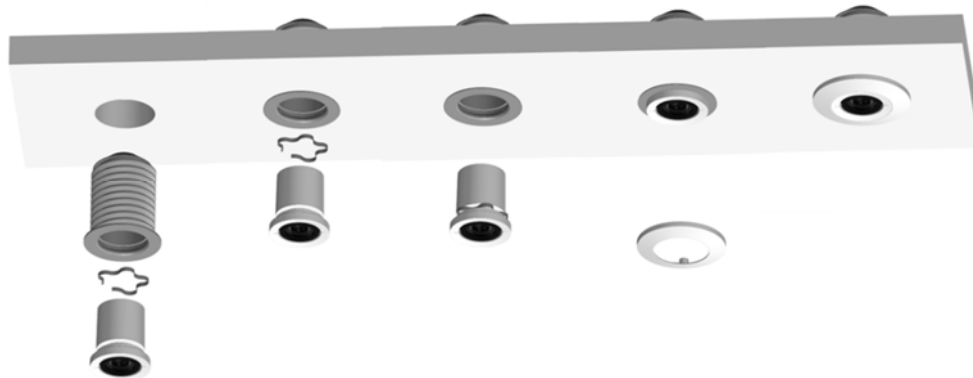

Figure 7.10: Simplified mounting, step by step, of the recessed camera.

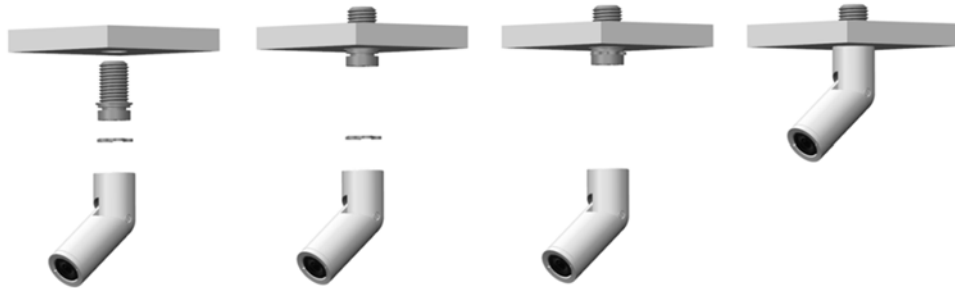

Figure 7.11: Simplified mounting, step by step, of the adjustable camera.

7.2 Materials and Surface Structures

Ceilings are often painted in matte colours and ceiling mounted devices should therefore also have matte colours to be as discreet as possible. The final design of the modular camera combines matte surfaces with glossy details. The camera needed to look exclusive and interesting seen from a short distance, to appeal to the purchaser, but be discreet when installed in the ceiling. Therefore the biggest part of the camera has a matte surface and the base unit, which will only be visible in the front, has a varnished surface to create an interesting look.

The base units should be made of aluminium, which will lower the weight but still protect the lens and circuit board inside. The components should be coated with a white or black colour, on the glossiness scale 90-100; super glossy. The chosen colours are white NCS S 0500-N and black NCS S 9000. The white colour is the most common tone for white painted ceilings, and the black colour is dark and neutral. The neutral black and white colours were chosen to minimise potential interference with colour tones in the interior.

The screw and sleeve nut that holds the two parts of the adjustable joint together should also be made of aluminium and coated like the base units, but with the same colour glossiness as the plastic parts.

The adjustable joint and cover plate should be made of thermoplastic, and come in the same colour variations as the base units, but on the glossiness scale 0-5; super matte. A plastic material is chosen because of the lower cost, lower weight and the complex details that require injection moulding.

The mounting screws should be made in a ferrous metal, which allows the magnets on the back of the cover plate to stick.

All materials and colour coatings should resist heat, oxidation and sunlight.

Other materials for the camera casings than plastic, such as wood or metal, were in the beginning regarded as an option, but the complex geometry of the adjustable joint became an obstacle. Instead, the possibility of creating customised skins was considered an option, but later excluded since this would change the geometry and appearance of the camera in a negative way. Still, the design of the cover plate for the recessed camera could be simplified and offered in other colours or materials without extreme additional costs.

8 Discussion

In this chapter the development process and the final design proposal will be discussed, followed by recommendations for further development.

It is important to pay attention to upcoming design trends when developing a new product, but while some products are meant to be frequently replaced others are intended for long term use. When developing a product for long term use, like a surveillance camera, a timeless design could be preferable. Trends can last for a very short time or become classics. Throughout history designers have been inspired by their precursors. It is not easy to forecast long lasting trends but by looking back through history one can find styles that never fully disappear.

The use of surveillance cameras engages a lot of people with different opinions. Surveillance cameras are not only a symbol of safety but can also seem intimidating for some people. This issue was discussed during the project and it was concluded that the new camera design should not be deterrent. Instead the camera should express care for the customers and their integrity and help both staff and shopping customers to feel secure. This issue was the reason for focusing on placing products of business competitors along an axis of *harmless* versus *deterrent* in the first sector chart, during benchmarking. Later in the project this axis was given new antonyms; *discreet* versus *visible*. Also the cameras in the second sector chart were more relevant competitors to the thought design. Focus was placed on low visibility instead of the potential fear of surveillance. Even if people dislike the thought of surveillance, the stores will still want to monitor their business. To please the boutique's interior designers and security managers a discreet camera was stated as most preferable. Today many stores have visible cameras to prevent crime by alerting the customers of the fact that they are being observed. The new cameras could be used together with one or two more visible cameras; this would make it possible to monitor the whole store without compromising the interior design but still letting customers know that the store is under surveillance.

Compromises regarding the customisability of the camera were unfortunately necessary along the way. The initial wish was that the customer would be able to modify the material and colour of the camera casing, but due to the complexity of the shape the decision was to offer only two different colours; white or black. This decision was also made based on observations that the store's ceilings often are painted in shades of black or white and that most retail environments have ceiling mounted devices in either black or white. Thus, the camera would draw less attention if it has a similar colour.

To improve the modularity of the camera additional mounting brackets could be considered. The “gooseneck” received a lot of positive attention. Due to time limitations this idea was not prioritised for further development but would most certainly be an interesting addition to the modular camera system. A mounting clamp was also discussed, but this idea was set aside since it would be more suitable for stores in the lower price segment because of the cable visibility. If the clamp was further developed the modular camera concept could address a larger market.

Figure 8.1 describes a common model of how different segments of the market tend to react to new products and trends. The vertical axis represents the amount of people and the horizontal axis represents the time span; usually months or years. The Pioneers are a relatively small group, prone to be curious about new trends. The Followers are the majority, who often wait for the pioneers to test and evaluate the product and for prices to go down before they decide to purchase the product.

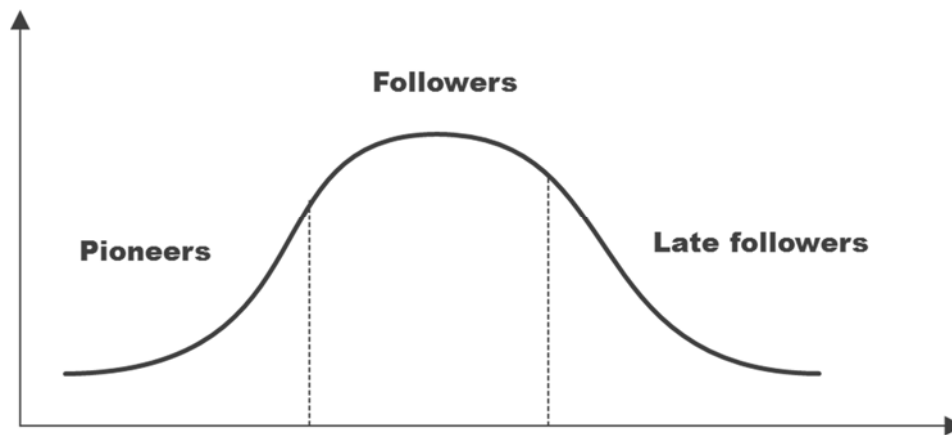

Figure 8.1: Chart illustrating three market segments and their acceptance of new trends.

The chosen target group of high-end stores were considered as pioneers that would inspire the followers in lower price segments. If the new camera would appeal to the high-end retailers, the followers would eventually discover the positive aspects of the discreet design. This was one of the main reasons to focus on the specific target group.

To reach a larger customer group the ceiling mounted cameras might need to be fireproof due to laws and regulations in other countries; e.g. the USA. This could be attained by attaching a rubber gasket inside the mounting screws. A rubber gasket would not only lead to a fireproof product, but provide a tight fit between the base unit and the mounting screw. Another security aspect to consider is the choice of cable connecting the cameras to the network. The cable used for the AXIS P12 series has a circular cross-section with a diameter of 5.5 mm. This cable is preferable because of its qualities, but can be replaced with a thinner cable in favour of a slim

design. A flat cable would lower the torsional stiffness, which is preferable when re-directing the camera. Using the cable for the AXIS P12-series could require larger dimensions of the adjustable camera casing or further development of stabilising the camera to resist the torsional force of the cable.

The camera is thought to be sold in a package including both mounting options. This would provide the customer with a versatile product suitable for a store where the interior design is often adjusted. The high-end stores usually change their placement of products for the new seasons and collections, which was one of the main reasons to make the camera easy to relocate. To make the camera even more versatile it could be of interest to broaden the selection of base units, providing not only wide-angle lenses but also e.g. telephoto lenses that could be used to gather images for identification.

9 References

- [1] Making the difference for retail (Electronic).
http://www.axis.com/files/brochure/bc_retail_48771_en_1209_lo.pdf,
2013-03-12
- [2] Axis Communications AB, About Axis (Electronic).
<http://www.axis.com/corporate/about/index.htm>,
2013-02-28
- [3] Axis P12 Network Camera Series (Electronic).
http://www.axis.com/products/p12_series/,
2013-03-11
- [4] User Manual, Axis P1204 Network Camera (Electronic).
http://www.axis.com/files/manuals/um_p1204_47873_en_1209.pdf,
2013-02-28
- [5] User Manual, Axis P1214 Network Camera (Electronic).
http://www.axis.com/files/manuals/um_p1214_47874_en_1209.pdf,
2013-02-28
- [6] User Manual, Axis P1214-E Network Camera (Electronic).
http://www.axis.com/files/manuals/um_p1214-e_47875_en_1209.pdf,
2013-02-28
- [7] Landqvist, J. (2001). *Vilda idéer och djuplodande analys, om designmetodikens grunder*. Carlsson Bokförlag, Stockholm, Sweden
- [8] Ulrich, K. T. & Eppinger, S. D. (2008). *Product Design and Development*, Fourth Edition. McGraw-Hill Higher Education, New York, USA
- [9] Bernsen, J. (1996). *Design'et før design'et*. Dansk Design Center, Copenhagen, Denmark
- [10] Prime, Richard, *Colour and Trend Forecaster, Oversight Trends*, lecture 7 February 2013

References

- [11] Plastteknik Sverige/Danmark 2013 (Electronic).
http://www.easyfairs.com/sv/events_216/plastteknik-sverigedanmark2013_24414/plastteknik-sverigedanmark-2013_24415/, 2013-06-16
- [12] Hedén, Emelie, Colour, Materials and Trend Forecaster, Veryday, lecture 10 April 2013
- [13] Andersen, Jens Christian, Camera Specialist, Axis Communications AB, Lund, personal conversation 8 March 2013
- [14] Åkesson, Johan, Director of Business Development – Retail, Axis Communications AB, Lund, personal conversation 22 March 2013
- [15] Andersen, Jens Christian, Camera Specialist, Axis Communications AB, Lund, personal conversation 25 June 2013
- [16] Åhman, Daniel, Design Lead, Axis Communications AB, Lund, personal conversation 13 March 2013

9.1 Image References

Figures without references are created by Erica Backe and Sara Novak with the programs Adobe Illustrator, Adobe Photoshop, Microsoft PowerPoint, Creo Parametric, Bunkspeed Shot or taken photographs.

- Bild 1: *En kamera från AXIS P12-serien.*
AXIS P1214 Network Camera (Electronic).
http://www.axis.com/products/cam_p1214/index.htm, 2013-05-24
- Figure 1.1: *The sensor units in the AXIS P12 series.*
AXIS P12 Network Camera Series (Electronic).
http://www.axis.com/products/p12_series/, 2013-05-24
- Figure 1.2: *Main unit connected to sensor unit.*
AXIS P12 Network Camera Series (Electronic).
http://www.axis.com/products/p12_series/, 2013-05-24
- Figure 3.1: *Early stage Sector Chart.*
Foscam fi9821w (Electronic).
<http://hi.atgimg.com/img/x/14613/fi8910wb.jpg>, 2013-03-12
ACTi Camera E32 (Electronic).
http://www.acti.com/file/Product/images/E32_L.jpg, 2013-03-12

- AXIS P33 Series (Electronic).
http://www.axis.com/products/p33_series/img/p33_models_ir.jpg,
2013-03-12
- AXIS Q1604-E Network Camera (Electronic).
http://www.axis.com/products/video/comparison/img/axis_q1602-e.jpeg, 2013-03-12
- AXIS M1004-W Network Camera (Electronic).
http://www.axis.com/products/cam_m1004w/, 2013-03-12
- AXIS 212 PTZ (Electronic).
http://www.heiwa-net.ne.jp/webcamera/imgs/axis_212ptz.jpg,
2013-03-12
- AXIS M5013 PTZ Dome Network Camera (Electronic).
http://www.axis.com/products/cam_m5013/, 2013-03-12
- Axis M3114-VE Surveillance Camera (Electronic).
<http://www.barcodesinc.com/axis/m3114-ve.htm>, 2013-03-12
- ACTi Camera KCM-7911 (Electronic).
http://www.acti.com/product/detail/Hemispheric_Camera/KCM-7911,
2013-03-12
- AVN805 (Electronic).
http://www.avtech.com.tw/index.php?option=com_k2&view=item&id=61, 2013-03-12
- AVN806 (Electronic).
http://www.avtech.com.tw/index.php?option=com_k2&view=item&id=72, 2013-03-12
- AVN284A (Electronic).
http://www.avtech.com.tw/index.php?option=com_k2&view=item&id=59, 2013-03-12
- PRODUCT ID: HDC255 (Electronic).
<http://www.cloverusa.com/cloverusa/productview?productid=x3L2UKyPr3>, 2013-03-12
- PRODUCT ID: HDC518 (Electronic).
<http://www.cloverusa.com/cloverusa/productview?productid=xcXEcYgImW>, 2013-03-12
- Clover OC285B Additional Night Vision Camera (Electronic).
<http://salestores.com/cloveroc.html>, 2013-03-12
- Hidden Camera (Electronic).
<http://www.indiamart.com/sn-telecom/digital-cameras.html>,
2013-03-12

References

- Infrared Dome Camera (Electronic).
<http://www.indiamart.com/premierbusiness/dome-camera.html>,
2013-03-12
- KT&C KPC-EJ230NUWX (Electronic).
http://www.2mcctv.com/product_info-KTCKPCEJ230NUWX.html,
2013-03-12
- Clover CCM660W Color Outdoor Bullet Camera (Electronic).
<http://www.amazon.com/Clover-CCM660W-Outdoor-Bullet-Camera/dp/B00009W3Z3>, 2013-03-12
- DCS-7010L - Revision A (Electronic).
<http://www.dlink.com/uk/en/support/product/dcs-7010loutdoor-hd-poe-day-night-fixed-mini-bullet-cloud-camera-with-ir-led>, 2013-03-12
- Crystal embedded security camera (Electronic).
<http://luci.ics.uci.edu/blog/?m=201106>, 2013-03-12
- Figure 3.2: *New Sector Chart.*
- AXIS M1004-W Network Camera (Electronic).
http://www.axis.com/products/cam_m1004w/, 2013-03-12
- Clover OC285B Additional Night Vision Camera (Electronic).
<http://salestores.com/cloveroc.html>, 2013-03-12
- Clover CCM660W Color Outdoor Bullet Camera (Electronic).
<http://www.amazon.com/Clover-CCM660W-Outdoor-Bullet-Camera/dp/B00009W3Z3>, 2013-03-12
- DCS-7010L - Revision A (Electronic).
<http://www.dlink.com/uk/en/support/product/dcs-7010loutdoor-hd-poe-day-night-fixed-mini-bullet-cloud-camera-with-ir-led>, 2013-03-12
- Crystal embedded security camera (Electronic).
<http://luci.ics.uci.edu/blog/?m=201106>, 2013-03-12
- Recessed mounting AXIS M3011/M3014 (Electronic).
http://www.axis.com/products/m30_series/, 2013-03-12
- Sony SNC-M3W User Guide (Electronic).
<http://www.manualowl.com/m/Sony/SNC-M3W/Manual/270785>,
2013-03-12
- Samsung's WiFi Home Security SmartCam (Electronic).
<http://www.wired.com/geekdad/2013/01/samsung-home-security-smartcam/>, 2013-03-12
- Spotlight Type Ceiling Mount Hidden CCTV Security Camera (CM5014 Series) (Electronic).
<http://sell.lulusoso.com/selling-leads/21815/Spotlight-Type-Ceiling-Mount-Hidden-CCTV-Security-Camera-CM5014-Series-.html>,
2013-03-12

Photo of Videolarm RC200 Ceiling Mount Wedge Security Camera Housing (Electronic).
<http://www.barcodemegastore.com/catalog/videolarm/rc200-ceiling-mount-wedge-housing-zoom.htm>, 2013-03-12

VideoSecu Pinhole Bullet 1/4in CCD Color Surveillance Cameras (Electronic).
<http://digiair.shop.rakuten.com/p/videosecu-pinhole-bullet-1-4in-ccd-color-surveillance-cameras/216472035.html>, 2013-03-12

Concealed Ceiling Mount cctv Camera ms-11(Electronic).
<http://camera513.en.busytrade.com/products/info/844556/Concealed-Ceiling-Mount-cctv-Camera-ms-11.html>, 2013-03-12

GOST Wood Mini Dome Aluminum Camera (Electronic).
<http://gostglobal.com/boat-alarms-yacht-alarm-and-tracking-packages/cameras.htm>, 2013-03-12

Figure 3.3: *Collage of identified customer environment characteristics.*

Luxury Private Pool Villa at Sri Panwa Resort (Electronic).
http://images.travelpod.com/tripwow/photos/ta-009a-9112-544d/luxury-private-pool-villa-at-sri-panwa-resort-phuket-thailand+1152_12802439453-tpfil02aw-22715.jpg, 2013-03-20

Magic Wine Bottle Balancer (Electronic).
http://st.houzz.com/simgs/4301309900cf83dc_4-6991/traditional-wine-racks.jpg, 2013-03-20

Wrapped Gift (Electronic).
<http://blog.hubspot.com/Portals/249/images/wrapped-gift.jpg>, 2013-03-20

Water Drop (Electronic).
https://encrypted-tbn0.gstatic.com/images?q=tbn:ANd9GcSUQ71ocquvqox7vFjJe2NWZUjE5mBEDg_pBXRuMRSnA23wVQon, 2013-03-20

Mark Fast Runway: Spring/Summer 2010 (Electronic).
<http://static.guim.co.uk/sys-images/Guardian/Pix/pictures/2009/9/19/1253385512787/Mark-Fast-Runway-SpringSu-001.jpg>, 2013-03-20

Are you attractive enough to work at Hollister? (Electronic).
http://westernwiremag.files.wordpress.com/2012/05/1-hollister_wallpaper5_smlmain.jpg, 2013-03-20

Figure 3.4: *Ceilings in high-end stores.*
 Photographs taken by Carl-Axel Alm, Kastrup, Copenhagen Airport, Denmark, 2013

References

Figure 4.1: *Mood Board used as inspiration for the camera design.*

Brown Recluse Spider Bite (Electronic).

<http://outdoorselfreliance.com/brown-recluse-spider-bite/>, 2013-03-28

CONSTELLATION JADE E21 SILK (Electronic).

http://www.fedrigonicartiere.com/Xerography/products_det.asp/Prodoto/CONSTELLATION+JADE+E21+SILK, 2013-03-28

Simply Elegant (Electronic).

<http://www.haleysonson.com/simplyelegant.htm>, 2013-03-28

Elegant and beautiful pink Chinese plum (08) (Electronic).

<http://www.natureplanet.info/Elegant-and-beautiful-pink-Chinese-plum/Elegant-and-beautiful-pink-Chinese-plum-08>, 2013-03-28

Michel Rajkovic – Minimalistic Waterscapes (Electronic).

<http://www.theddi.com/inspiration/michel-rajkovic-minimalistic-waterscapes/>, 2013-03-28

Tom Dixon Void Lamp (Electronic).

<http://www.bonluxat.com/a/tom-dixon-void-lamp.html>, 2013-03-28

The Logitech Comfort Lapdesk Is Shiny and Very White (Electronic).

http://www.gizmodo.com.au/2008/12/the_logitech_comfort_lapdesk_is_very_shiny_and_very_white-2/, 2013-03-28

WIRE WARE BY NAOTO FUKASAWA (Electronic).

<http://www.medesignmag.com/products/2870/wire-ware-by-naoto-fukasawa/gallery/12311/#contents>, 2013-03-28

Seamless chrome metal surface, background (Electronic).

http://www.colourbox.com/vector/seamless-chrome-metal-surface-background-vector-4718321?utm_expid=22365066-12.LQUruejPQVuO46hzBZUNtA.0&utm_referrer=https%3A%2F%2Fwww.google.se%2F, 2013-03-28

Figure 4.2: *Inspirational collage with the theme: technology – nature.*

iPhone Spider concept (Electronic).

<http://freshgadgets.nl/iphone-spider-concept>, 2013-04-03

Water Drop (Electronic).

https://encrypted-tbn0.gstatic.com/images?q=tbn:ANd9GcSUQ71ocquvqox7vFjle2NWZUjE5mBEDg_pBXRuMRSnA23wVQon, 2013-04-03

Tron-inspired jacuzzi lets you bathe in the waters of the future (Electronic).

http://www.dvice.com/archives/2011/04/tron_inspired_j.php, 2013-04-03

Jellyfish (Electronic).
http://fuzhou.chinadaily.com.cn/e/2011-09/19/content_13735733.htm,
2013-04-03

Sony a352 Concept DSLR Camera Design (Electronic).
<http://petapixel.com/2010/04/10/sony-a352-concept-dslr-camera-design/>, 2013-04-03

STRANGE INSECTS - CLOSE UP! - BIG EYES (Electronic).
<http://www.strangezoo.com/content/item/151004.html>, 2013-04-03

The Magnificent Nautilus Shell (Electronic).
<http://www.fantasticforwards.com/the-magnificent-nautilus-shell/>,
2013-04-03

Pearl River Tower (Electronic).
<http://urbantoronto.ca/forum/showthread.php/10548-Arch-Record-At-Least-50-Tall-Buildings-Now-on-Hold>, 2013-04-03

Figure 7.6: *Pictures assembled in Photoshop to show the products in an example of their intended environment.*

Background picture:

Shoppers Drug Mart to open five new Murale stores (Electronic).
<http://www.premiumbeautynews.com/en/Shoppers-Drug-Mart-to-open-five,1181>, 2013-09-06

Appendix A: Initial Project Plan

week	1	2	3	4	5	6	7	8	9	10	11	12	13	14	15	16	17	18	19	20
Preface	Gathering Information																			
	Processing Information																			
	Idea Generation																			
	Choice of Methodology																			
	Function Analysis																			
	Brief																			
	Moodboard																			
Field studies Interviews/Surveys																				
Concept Generation and Refinement	Concept Generation																			
	Test/Evaluation of Concept 1																			
	Concept Refinement																			
Test/Evaluation of Concept 2																				
Final Product	Refinements																			
	Final Model																			
	3D Printing of Model																			
Other Elements of Thesis	Documentation																			
	Prepare Opposition																			
	Opposition																			
	Compilation of Report																			
	Prepare Presentation																			
Presentation																				

Appendix B: Final Project Plan

All parts of the project were made in collaboration between Erica Backe and Sara Novak.

week	1	2	3	4	5	6	7	8	9	10	11	12	13	14	15	16	17	18	19	20
Preface	Gathering Information																			
	Processing Information																			
	Idea Generation																			
	Choice of Methodology																			
	Function Analysis																			
	Brief																			
Concept Generation and Refinement	Moodboard																			
	Field studies																			
	Interviews/Surveys																			
	Concept Generation																			
	Test/Evaluation of Concept 1																			
	Concept Refinement																			
Final Product	Test/Evaluation of Concept 2																			
	Refinements																			
	Final Model																			
	3D Printing of Model																			
	Documentation																			
	Prepare Opposition																			
Other Elements of Thesis	Opposition																			
	Compilation of Report																			
	Prepare Presentation																			
	Presentation																			

Appendix C:

Interview with Jens Christian Andersen

Jens Christian Andersen [13] [15], Camera Specialist at Axis and former installer of security cameras, was interviewed about installation and security in retail environments. Throughout the project Jens Christian Andersen was consulted and this Appendix is a summary of the ideas, comments and discussions from the conversations.

Interviewing Jens Christian Andersen early during the project provided useful information about camera placement, customer requirements and security in retail. The main difference between camera surveillance in high-end retail and e.g. petrol stations is the type of crimes committed. Armed robberies are rare in high-end stores, where the main focus instead is on shoplifting. This affects the camera placement.

Later in the project some concepts were discussed and Jens Christian Andersen thought that a customisable camera was interesting. His experience was that many stores spray-colour their cameras to make them blend in with the rest of the environment, and therefore it could be a good idea to provide coloured skins, or skins that easily could be removed to facilitate colouring.

Jens Christian Andersen was also positive to the “gooseneck” solution and suggested areas of use; for example mounting the camera on top of a shelf to monitor the customers and prevent shop-lifting.

In the development of a mounting solution for the camera different ceiling materials were discussed. The most difficult material for mounting was found to be concrete or stone. Jens Christian Andersen’s experience was that concrete ceilings are rare in high-end stores with many recessed devices, such as spotlights and sprinklers. In occasions where concrete or stone is unavoidable, extensive preparation work will be necessary for all installations, and usually an inner ceiling is installed to facilitate mounting. This information led to the decision that a mounting solution for concrete or stone was disregarded.

Appendix D: Interview with Daniel Åhman

Daniel Åhman [16], Design Lead at Axis, was consulted concerning shapes, trends and customer requirements and also took part in the concept selection. This appendix is a summary of the discussions with Daniel Åhman.

In the first meeting, during the pre-study, Daniel Åhman thought that making a camera design adapted to the intended environment was interesting and had considered the possibility of making an architect product line, focused on carefully or sparsely decorated interiors.

The most frequently used camera types in high-end retail were discussed. According to Daniel Åhman small cylinder-cameras, also known as “bullet cameras”, are common in high-end stores and thought that this camera design could be further investigated. The concept of a corner camera was also interesting because of its ability to blend in with the environment without casting shadows.

The later conversations with Daniel Åhman led to a further investigation of three main concept lines; the small cylinder camera, the half-hidden “spotlight camera” and the corner camera. These concepts are presented in chapter 5.1.

Appendix E: Interview with Johan Åkesson

Johan Åkesson, Director of Business Development – Retail at Axis [14] was interviewed after the first concept selections. Johan Åkesson manages customer relations and has experience of purchasers' requirements for high-end surveillance.

Through the meetings with Johan Åkesson, during the concept selection and concept refinement, relevant knowledge of the buyers' requirements was gained. According to Johan Åkesson surveillance in high-end stores mainly has four purposes; identification, people counting, heat tracing and overview.

An identification camera is usually hidden and placed at eye-level. A camera for people counting is used to count the amount of people passing by a certain area in a store. A heat tracing camera shows the activity in certain areas; the more people stopping at one place, the more heat will be observed and shown in the picture. In this way it is possible to evaluate placements of products and how much attention the products attract. A camera for heat tracing can be placed far from the monitored area and might require adjustability. Typical angles for the horizontal field of view for video analytics are 100-135 degrees or wider. Overview cameras often have wide angle lenses and can therefore be fixed when installed.

After the conversation about surveillance purposes in high-end retail it was decided that the camera design should be focused towards people counting, heat tracing and overview.

Johan Åkesson gave positive feedback on the suggestions of a fixed recessed camera, a "gooseneck" adjustable camera and a corner camera. It was also concluded that a very discreet camera was preferable and that a lens cover, to minimise the camera appearance, could attract more customers.

Appendix F: Screen Shots from Tests in Laboratory

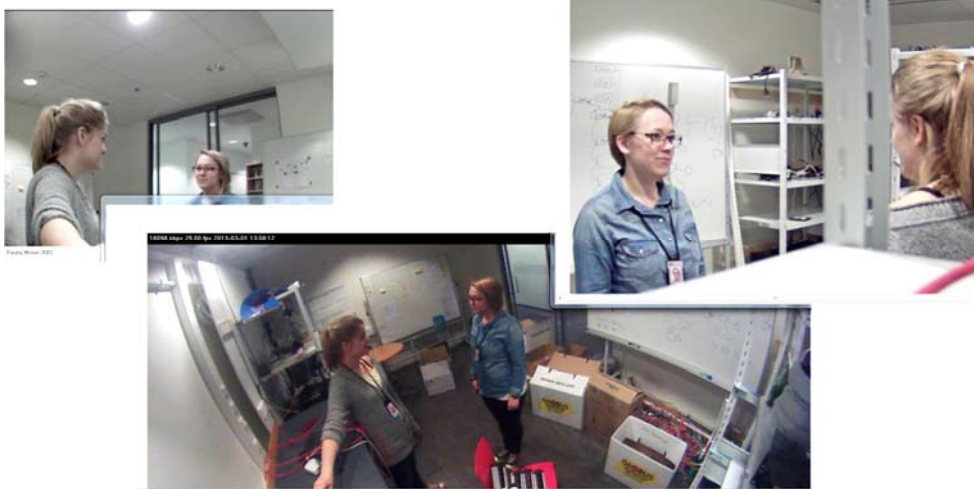

Different camera angles were tested at the same time to evaluate how many cameras were necessary to cover most possible situations by a cash register in a store, see pictures above. The conclusion was that a minimum of three cameras located in different places, and with different fields of view, was the best solution to cover both identification and overview.

Appendix F: Screen Shots from Tests In Laboratory



The two pictures above show the difference in resolution of a face, depending on the distance from a wide angle camera. The pictures are taken with a fisheye lens which provides good overview of the room but could require a supplementary camera, with a narrower field of view, if images for identification are requested.

Appendix F: Screen Shots from Tests In Laboratory



The pictures above show the difference between corridor format and standard format; how it can be difficult to place a camera for absolute coverage.

Appendix G: Concept Scoring

This table shows the Concept Scoring discussed in chapter 5.4.

Selection Criteria	Weight	Concepts					
		03 Corner	06 Adjustable joint	67 Gooseneck	71 Recessed	75 Magnetic ball and socket joint	
Stable after installation	25	Rating 5	Rating 4	Rating 1	Rating 5	Rating 2	Weighted Score 50
Possible to manufacture	20	Rating 5	Rating 4	Rating 5	Rating 5	Rating 3	Weighted Score 60
Enable connection cable diameter, out from casing	15	Rating 5	Rating 5	Rating 3	Rating 5	Rating 3	Weighted Score 45
Easy installation	5	Rating 2	Rating 4	Rating 4	Rating 4	Rating 4	Weighted Score 20
Discreet appearance	10	Rating 4	Rating 3	Rating 2	Rating 5	Rating 3	Weighted Score 30
Enable redirection	10	Rating 1	Rating 5	Rating 4	Rating 1	Rating 3	Weighted Score 30
Allow relocation	15	Rating 1	Rating 5	Rating 5	Rating 5	Rating 5	Weighted Score 75
Total Score		375	430	325	455		310
Rank		3	2	4	1		5

Appendix H: Drawings of Final Design

All measurements in the drawings are in millimeters. The drawings are presented in the following order:

1. Base unit 1
2. Base unit 2
3. Mounting Screw Recessed
4. Mounting Screw Adjustable
5. Cover plate
6. Adjustable Joint Part 1
7. Adjustable Joint Part 2
8. Screw & Sleeve Nut

Appendix H: Drawings of Final Design

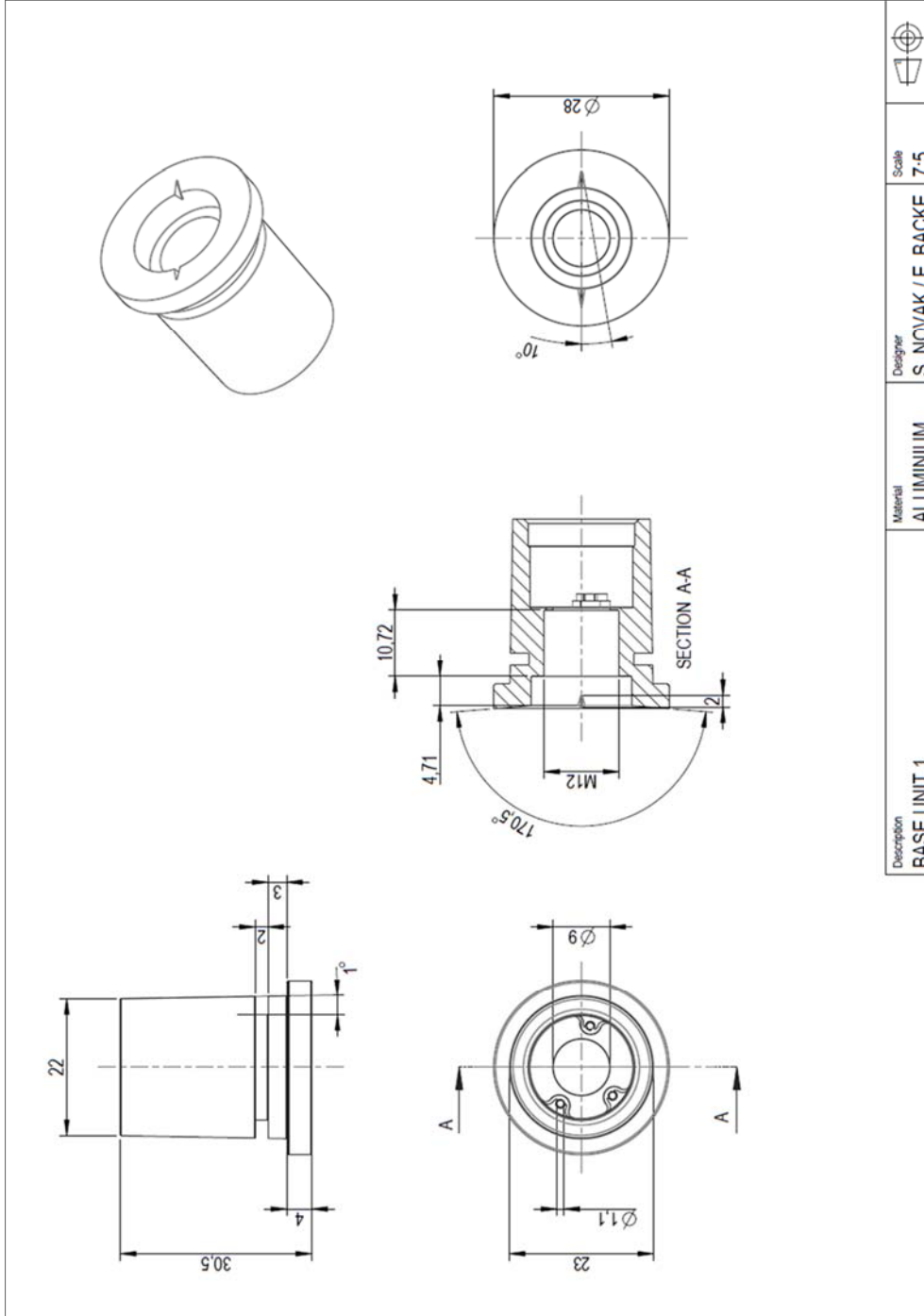

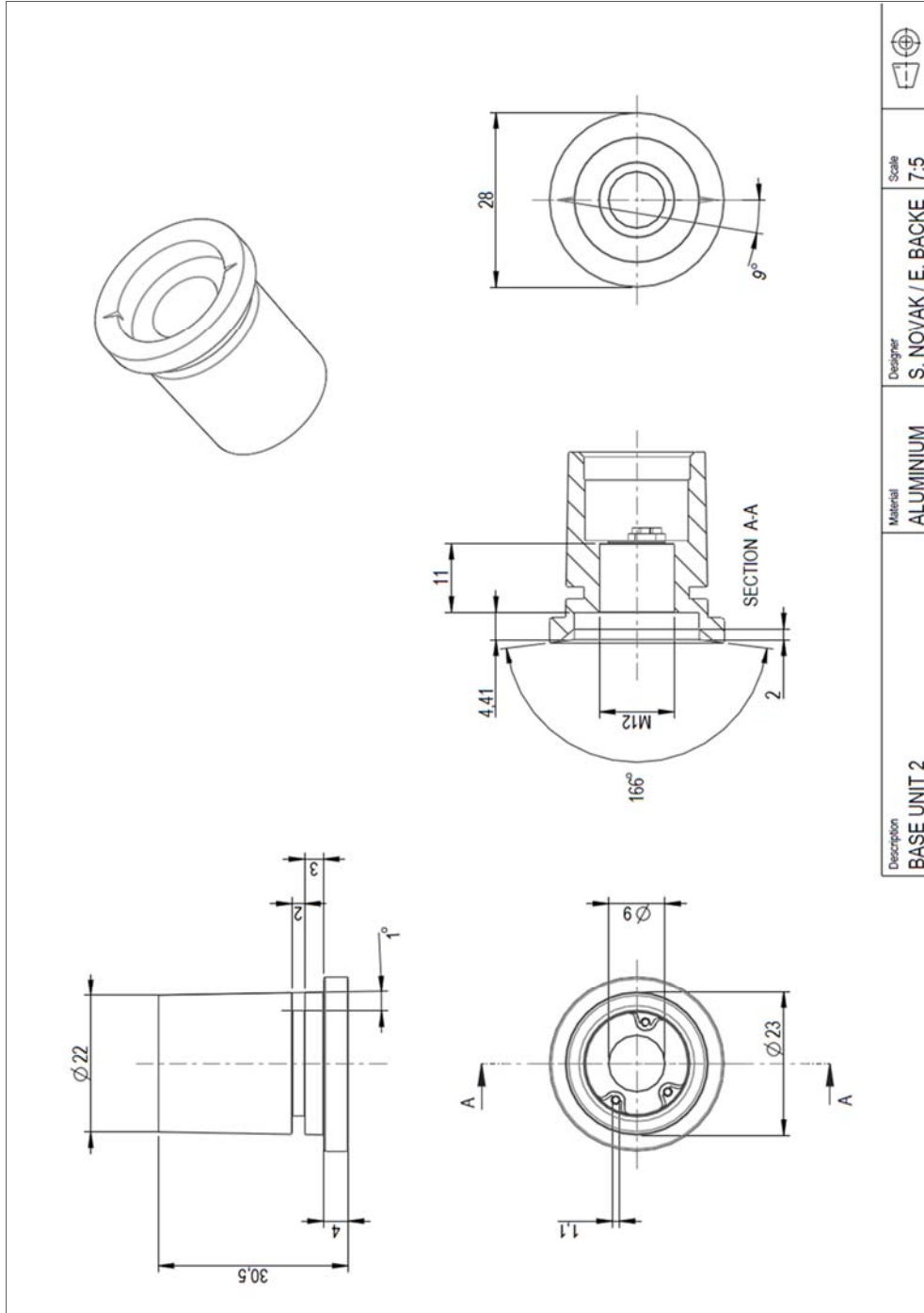

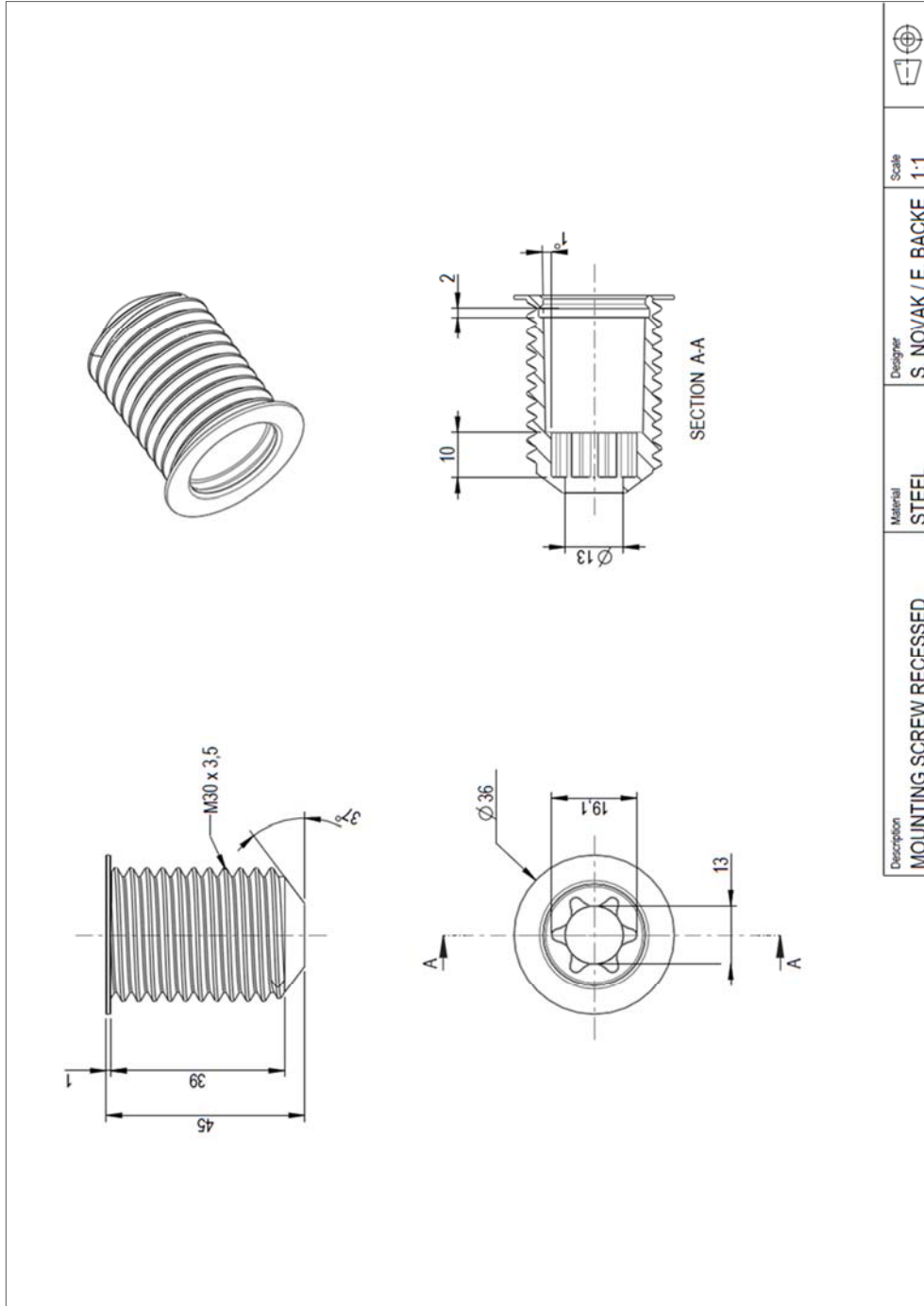

Appendix H: Drawings of Final Design

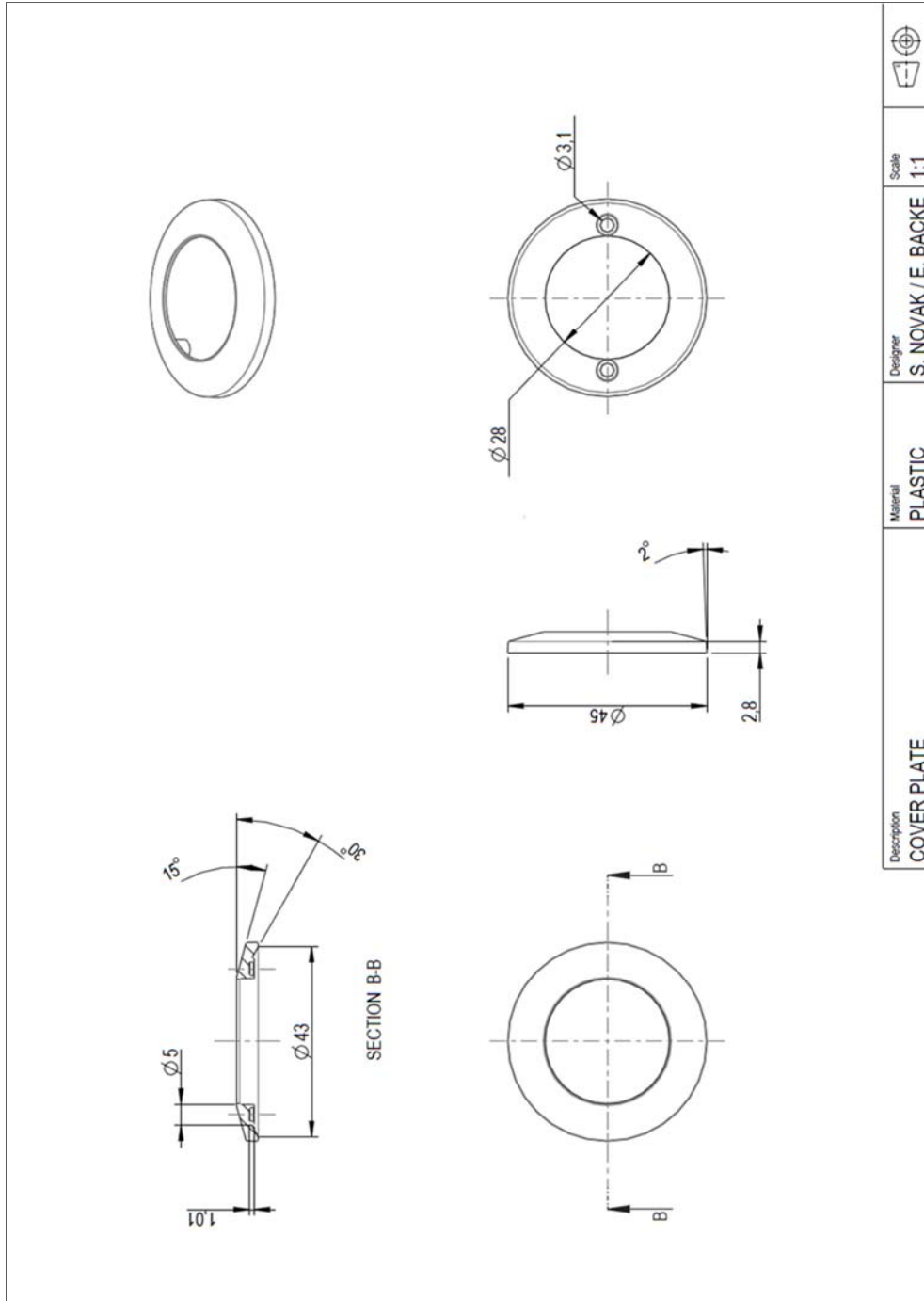

Scale	1:1	Designer	S. NOVAK / E. BACKE	Description
			STEEL	MOUNTING SCREW RECESSED

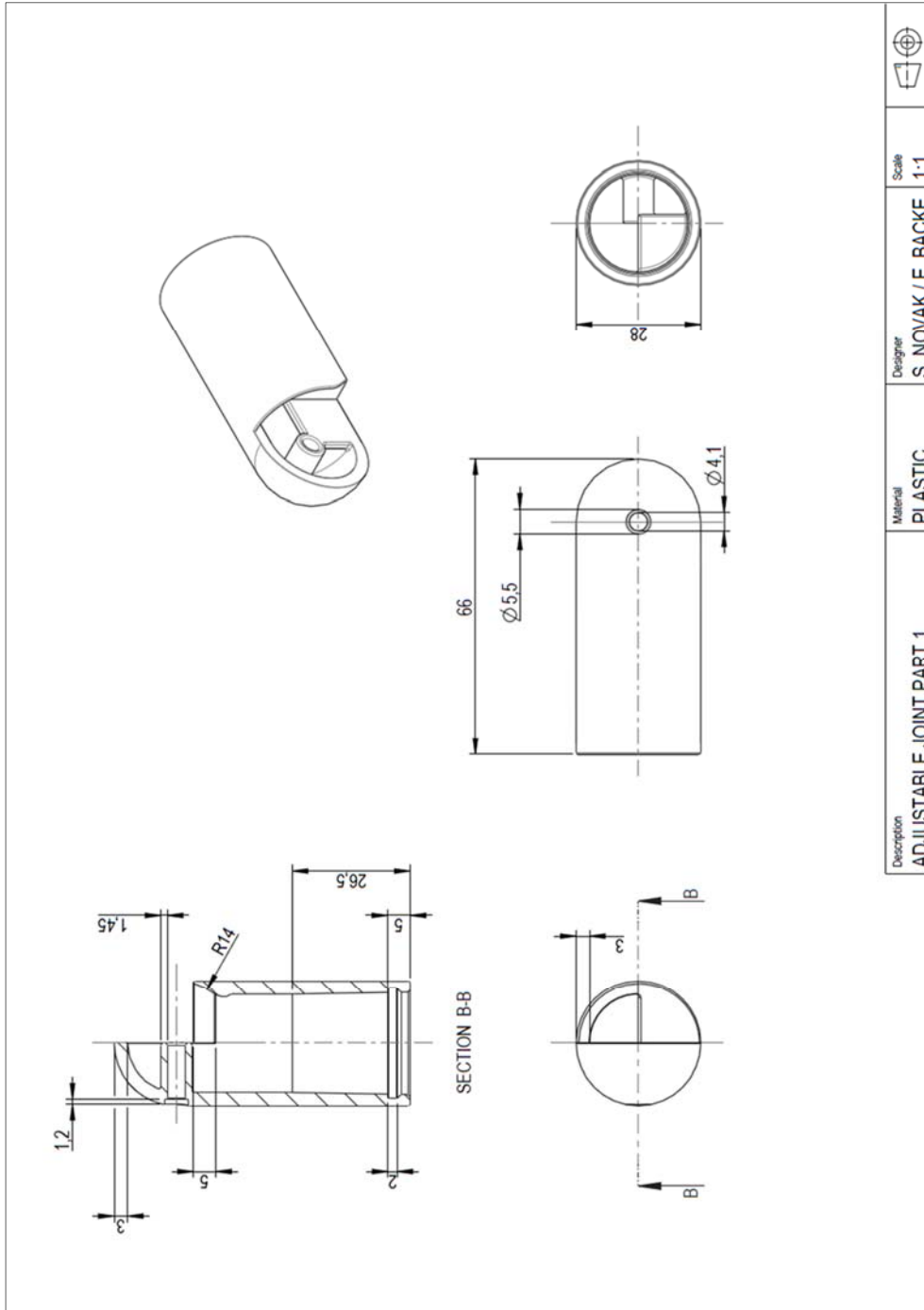



					
		Scale	Designer	Material	Description
		1:1	S. NOVAK / E. BACKE	PLASTIC	ADJUSTABLE JOINT PART 1

Appendix H: Drawings of Final Design

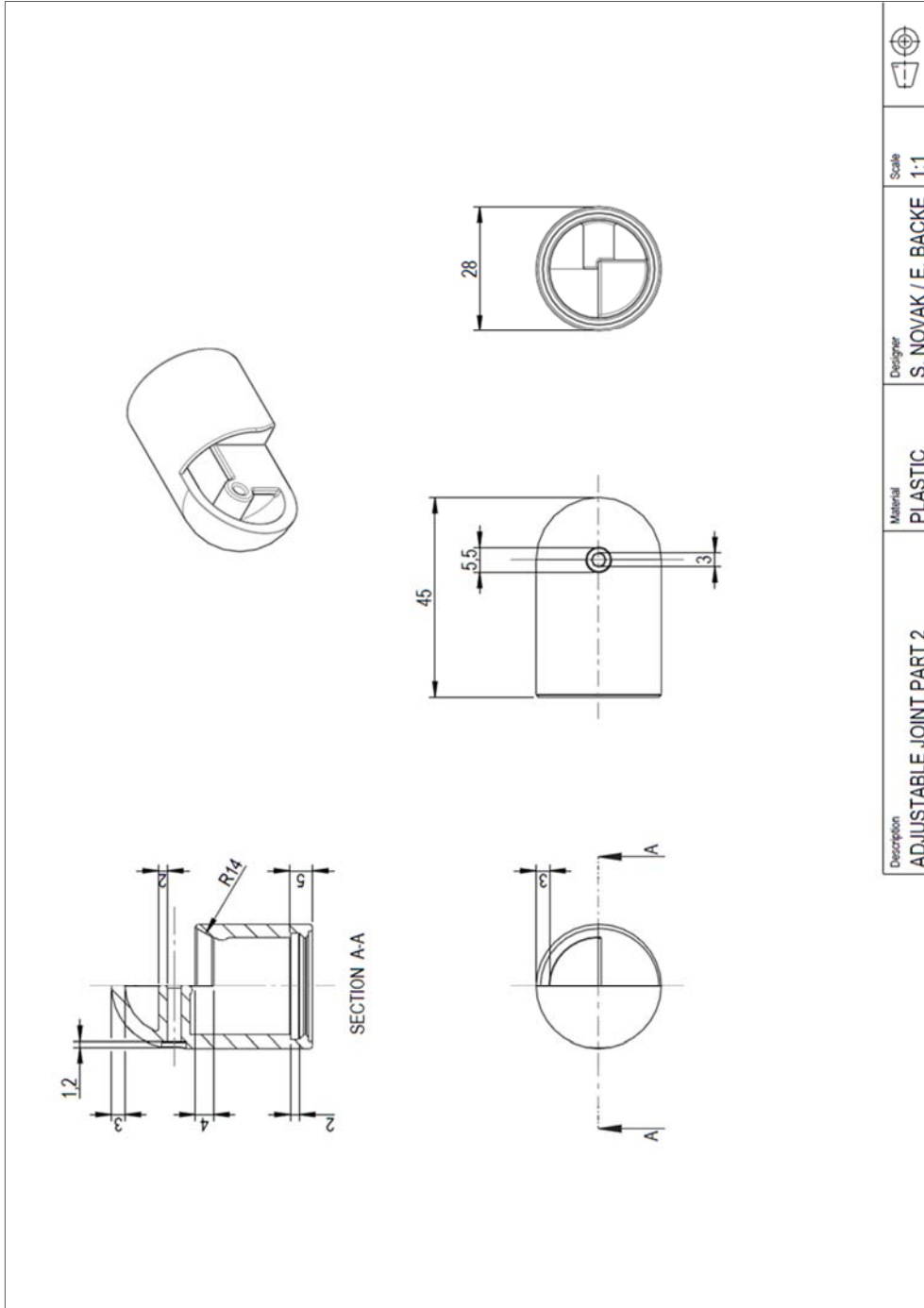

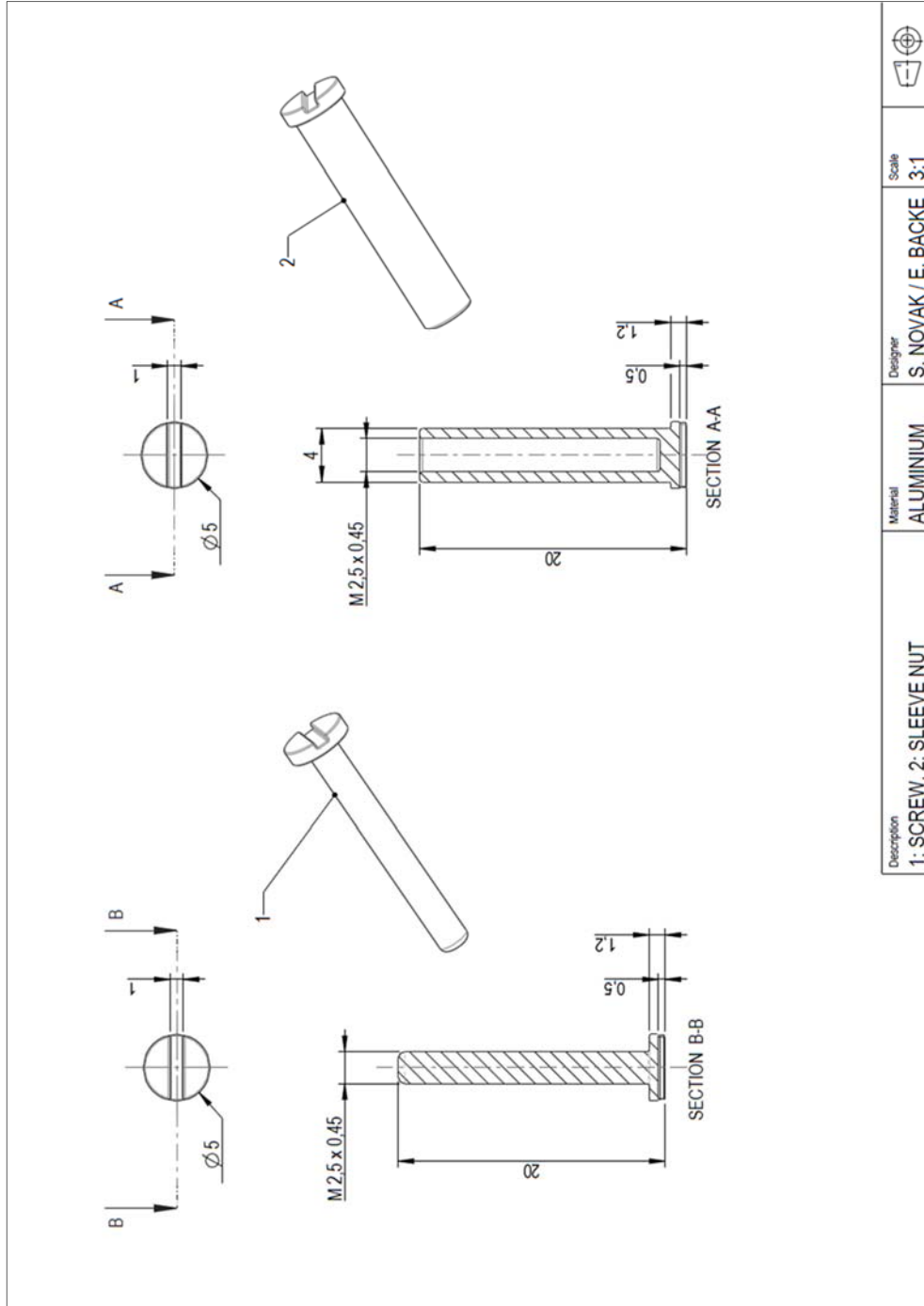

Description 1: SCREW, 2: SLEEVE NUT	Material ALUMINIUM	Designer S. NOVAK / E. BACKE	Scale 3:1	
----------------------------------------	-----------------------	---------------------------------	--------------	--