



LUND UNIVERSITY  
School of Economics and Management

Lund University School of Economics and Management  
Department of Business Administration

BUSN69  
*Master Degree Project*

Spring 2014

# The Process of Changing the Audit Report in an International Context

**Authors:**

Tina Jönsson  
Karin Svensson

**Advisors:**

Amanda Sonnerfeldt  
Anne Loft

## **Abstract**

**Title** The Process of Changing the Audit Report in an International Context

**Seminar date** 2014-06-02

**Course** BUSN69 Degree Project – Accounting and Auditing, 15 ECTS credits

**Authors** Tina Jönsson and Karin Svensson

**Advisors** Amanda Sonnerfeldt and Anne Loft

**Five key words** Audit Report, ISA 700, IAASB, IFAC, Regulatory Space

**Purpose** In the light of IAASB's due process and its relationships with international organizations, the purpose of this thesis is to provide an understanding of the political process of changing the audit report standard and the context in which this takes place.

**Methodology** The methodology undertaken is mainly based on a qualitative approach to document studies. The research questions have been addressed by a document analysis of both primary and secondary sources. A form of content analysis of comment letters to the proposed new audit report standard is also performed.

**Theoretical perspectives** The theoretical framework consists of the concept of regulatory space. This perspective provides a basis for how to approach the audit report changing process, and serves as an analytical tool for analyzing the participating actors, their motivations for involvement and the interactions and relationships between organizations.

**Empirical foundation** The empirical findings consist of three parts. The first two chapters outline the the history of changes to the audit report as well as the development and role of IFAC and IAASB in the international audit arena, within a context of other important organizations. The last part discusses the current due process of consultation with focus on the influence of stakeholders to IAASB's proposed new audit report rules.

**Conclusions** This thesis argues that main actors, consisting of e.g. a group of international regulators are active in the shaping of the regulatory space and the initiation of regulatory conversations, such as the issue of the audit report. It is shown that the IFAC and IAASB act in a context consisting of heavily interlocking organizational relationships. Further, it is in the process of changing the audit report seen that IAASB needs to consider a myriad of different opinions and that not all wishes can be fulfilled. Some findings indicate that a few actors are not successful in influencing the approach taken in the audit report change. Based on the ambiguous findings, it is however not reasonable to distinguish some actors as more or less successful than others in influencing the proposed rules.

## Acknowledgements

We would like to take the opportunity to thank our supervisors Amanda Sonnerfeldt and Anne Loft for valuable guidance and interesting discussions.

Lund, 26 May 2014

---

Tina Jönsson

---

Karin Svensson

## Table of content

<b>1. Introduction</b> .....	9
1.1 Problem Discussion .....	9
1.2 Purpose and Research Questions .....	11
1.3 Position of This Thesis.....	11
1.4 Delimitations.....	12
1.5 Structure of the Thesis .....	13
<b>2. Methodology</b> .....	14
2.1 Approach to Research.....	14
2.2 Connection between Theory, Analysis and Data .....	15
2.3 Approach to Research Question 1.....	16
2.3.1 Data Collection to Research Question 1.....	16
2.4 Approach to Research Question 2.....	16
2.4.1 Selection of Focus Area .....	18
2.4.2 Content Analysis .....	19
2.4.3 Selection of Respondents.....	20
2.4.4 Empirical Presentation .....	21
2.5 Reliability and Validity.....	21
2.6 Ethical Considerations .....	22
2.7 Chapter Summary .....	23
<b>3. Theoretical Framework</b> .....	24
3.1 The Concept of Regulatory Space .....	24
3.2 Use of Theory .....	24
3.3 Regulatory Space as defined by Hancher and Moran .....	25
3.4 Young: “Outlining Regulatory Space...” .....	27
3.5 Jonnergård and Larsson: “Developing Regulatory Space...” .....	28
3.6 Analytical Framework .....	28
3.7 Chapter Summary .....	29
<b>4. The Development of the Audit Report</b> .....	30
4.1 The Development of the Standard Audit Report.....	30
4.2 The Development and Current Requirements of ISA 700 .....	31
4.3 How the change of the audit report came to the agenda .....	33

4.4 Chapter Summary .....	35
<b>5. The Context</b> .....	<b>36</b>
5.1 The IFAC structure .....	36
5.1.1 IFAC.....	36
5.1.2 <i>The Three-tier Structure of IFAC, PIOB and the Monitoring Group</i> .....	37
5.1.3 IAASB.....	39
5.2 Key Players in International Audit Regulation .....	41
5.2.1 <i>The European Union</i> .....	43
5.2.2 <i>International Organization of Securities Commissions</i> .....	44
5.2.3 <i>The United States</i> .....	44
5.2.4 <i>International Forum of Independent Audit Regulators</i> .....	45
5.2.5 <i>Multinational audit firms</i> .....	46
5.3 Organizational Relationships .....	47
5.4 Chapter summary .....	47
<b>6. The Development of Key Audit Matters</b> .....	<b>49</b>
6.1 Background to the Consultation Paper.....	49
6.2 The Consultation Paper, 2011 .....	49
6.3 The Invitation to Comment, 2012 .....	51
6.4 The Exposure Draft, 2012.....	52
6.5 Comment letters .....	54
6.5.1 <i>Overall support for Auditor Commentary</i> .....	57
6.5.2 <i>For which entities Auditor Commentary should be required</i> .....	57
6.5.3 <i>Preparers of Financial Statements</i> .....	58
6.5.4 <i>Investors and Analysts</i> .....	59
6.5.5 <i>The Big Four Audit Firms</i> .....	59
6.5.6 <i>Regulators and Oversight Bodies</i> .....	60
6.6 Views on Specific Issues .....	61
6.6.1 <i>Whether or Not to Include Materiality</i> .....	61
6.6.2 <i>Whether the Use of Key Audit Matters Should be Voluntary for Other Audits</i> .....	62
6.6.3 <i>How to Select Key Audit Matters</i> .....	63
6.6.4 <i>Key Audit Matters in Relation to Emphasis of Matter and Other Matters</i> .....	65
6.7 Chapter Summary .....	655
<b>7. Analysis</b> .....	<b>67</b>

7.1. The Construction of Regulatory Space .....	67
7.2 Organizational Relationships .....	68
7.3 The Audit Report becomes a “problem” .....	69
7.4 Stakeholder Influence on the Proposed New Audit Report .....	70
7.4.1 <i>The Actors’ Overall Influence on the New Audit Report Section</i> .....	71
7.4.2 <i>The Actors’ Influence on Certain Issues</i> .....	73
7.5 Chapter Summary .....	75
<b>8. Conclusions</b> .....	76
<b>9. Reflections</b> .....	78
<b>References</b>	
<b>Appendices</b>	

## List of Figures

	Page
Figure 1: The Different Consultation Papers	17
Figure 2: Overview of Audit Report Due Process	35
Figure 3: Main Structure of IAASB and IFAC	38
Figure 4: Options for Change	50

## List of Tables

Table 1: The Main Elements of Current ISA 700	32
Table 2: Key Players in The International Audit Regulation	42
Table 3: Organizational Relationships	47
Table 4: The Auditor Commentary Definition	52
Table 5: The Key Audit Matters Definition	53
Table 6: The Overall Opinion Regarding Auditor Commentary	56
Table 7: Materiality Included in The Auditor Commentary	62
Table 8: Auditor Commentary Voluntary	63
Table 9: Matters Communicated with Those Charge With Governance	65
Table 10: Emphasis of Matter and Other Matter Paragraphs	66
Table 11: Compilation of Identified Issues	74
Table 12: Requirement of Auditor Commentary	75

## **Abbreviations**

AICPA American Institute of Certified Public Accountants  
ASB - Auditing Standards Board (of AICPA)  
BCBS Basel Committee on Banking Supervision  
CAG Consultative Advisory Group  
EC European Commission  
EU European Union  
FASB Financial Accounting Standards Board  
FSF Financial Stability Forum  
FSB Financial Stability Board  
FRC Financial Reporting Council  
GPPC Global Public Policy Committee  
GSC Global Steering Committee  
IAASB International Auditing and Assurance Standards Board  
IAIS International Association of Insurance Supervisors  
IAPC International Auditing Practices Committee  
IASB International Accounting Standards Board  
IFAC International Federation of Accountants  
IFIAR International Forum of Independent Audit Regulators  
IFRS International Financial Reporting Standard  
IMF International Monetary Fund  
IOSCO International Organisation of Securities Commissions  
IRLG IFAC's Regulatory Liaison Group  
ISA International Standard on Auditing  
PCAOB Public Company Accounting Oversight Board  
PIE - Public Interest Entity  
PIOB Public Interest Oversight Board  
SEC Securities and Exchange Commission  
SME Small and Medium-sized Enterprise



## **1. Introduction**

The primary tool for auditors to communicate with users of financial statements is the audit report. The purpose of the audit could be explained by that it fills a function “where there is a duty of accountability between two parties...and that an audit is the means by which accountability is ensured” (Flint, 1988, p. 12). To improve the degree of confidence of users in the financial statements, the auditor expresses an opinion on whether the financial statements are prepared in accordance with a financial reporting framework. This opinion is based on whether the financial statements present a true and fair view (Adiloğlu & Vuran, 2011) For investors and analysts the audit report with its audit opinion is the only distinct source for gaining insight into the audit. This makes it an essential document with an important content (MARC, 2009; Porter, Simon & Hatherly, 2008).

The content and coverage of the audit report has been subject to discussions over time and have sometimes been changed or revised as a response. Even so, the audit report has for a long time due to its standardized format and wording been seen as a “uniquely uninformative” and boring letter that looks almost the same for every company (Sawers, 2012). This is now all about to change. The International Auditing and Assurance Standards Board (IAASB), who sets international auditing standards (ISAs) has put the change of the audit report as a top priority on its agenda and is proposing additions that dramatically changes the content of the audit report and the work of auditors. Auditors will now be required to tailor the report to each client and provide insights to the audit of the financial statements, such as difficulties with the audit, key risks and areas of subjective management judgments (IAASB, 2013). This will change the report from being one page to cover several pages. The proposed new rules are by the chairman of IAASB itself called “A Game Changer” and “The Beginning of a New Era” (Schilder, 2013).

### **1.1 Problem Discussion**

As mentioned in the introduction the standard audit report is undergoing major changes. The IAASB, the Public Company Accounting Oversight Board (PCAOB) of the United States (US) as well as the European Commission (EC) are all under the process of separately enhancing their audit report and finalizing the rules. Something they all have in common is introducing requirements for the auditor to provide additional information about the key areas of the audit in order to make the audit report more informative (PwC, 2013). There are however different views about if it is appropriate for the auditor to provide additional information (see for example IOSCO Technical Committee, 2010).

Some calls for change, coming from institutional investors and regulators (IOSCO Technical Committee, 2009; ACAP; 2008) have addressed the lack of informative value of the audit report and stressed the importance of filling an information gap, namely between what investors and analysts believe they need to make investment decisions and what is publicly available to

them. This information gap has arisen from that the financial statements has become more complex and long while the disclosures in the audit report has not increased with it. A consequence of this information gap is that the investors want to understand what judgments the auditor may have done in the process to reach an audit opinion on the financial statements and which areas that might have been considered risky. This in turn has led to that the investors want more information in the audit report about the insights the auditor has through its audit of the entity (ICAA, 2013).

In line with IAASB's new governance structure and work in the public interest, the due process of standard setting now involves collecting views from a broad spectrum of stakeholders. The due process of changing the audit report has from 2011-2013 gone through three consultation rounds where the public could submit comments to the IAASB and give their opinions and suggestions regarding the different proposals. Even if the due process could be seen as a comprehensive process undertaken by IAASB to take into account and listen to different stakeholders, a due process does not necessarily mean that information gathered affects the decision-making of the standard-setter (MacDonald & Richardson, 2004) What can be said about a due process is that a particular process is followed and that it is used as a way of legitimizing the standard, i.e. the result of the due process (MacDonald & Richardson, 2004). Thereby it is interesting to study whether the comments by the respondents to the consultation papers are successful in influencing the standard setter's continued approach, or if some respondents are more influential than others.

While many prior studies concerning the audit report focus on how users perceive the audit report, the difficulties with it and areas in which it needs to be improved, we find it interesting to look at the political process of changing it. This includes looking at the pressures and different interests of actors that try to influence the change. A way of doing this is to adopt the lens of the regulatory space, which sees regulation as occurring in an abstract space that is occupied by major and minor participants that struggle for their benefits (Hancher & Moran, 1989) This concept recognizes the complexity of both the standard setting and the agenda formation processes and it leads the researcher to the question of who is involved in the regulation process and who is inside and outside the regulatory space. By doing that, it is not enough to just consider the standard setter, in this case the IAASB, the researcher needs to look outside the organizational borders and turn attention to the interaction with different actors and institutions that contribute to the processes of change (Young, 1994). Also identifying how regulatory arrangements have come to be in the past is important for understanding how the arrangements work today (Hancher & Moran, 1989). When studying international audit regulation, researchers have pointed towards the important and influential relationship between international regulators, the large audit firms and International Federation of Accountants (IFAC) (Humphrey, Loft & Woods, 2009). This means that it is interesting to study not only the standard changing process

of IAASB and IFAC as if in a vacuum, but how they act in a global context of stakeholders that are involved and trying to influence the audit standard setting process as well.

## **1.2 Purpose and Research Questions**

In the light of IAASB's due process and its relationships with international organizations, the purpose of this thesis is to provide an understanding of the political process of changing the audit report standard and the context in which this takes place.

Questions we seek to answer are:

1. Who are the main actors influencing IAASB and how are they participating in the regulatory space in which audit report regulation is changing?
2. In the due process of stakeholder consultation, is it possible to see whether some actors are more successful than others in influencing the proposed rules to the new audit report?

## **1.3 Position of This Thesis**

In a number of articles from the last decade it has been argued for the growing importance of IFAC in the "new financial infrastructure" and the interesting context in which international audit regulation occurs (Loft, Humphrey & Turley, 2005; Loft, Humphrey & Woods, 2009; Humphrey & Loft, 2009, Humphrey & Loft, 2012; Malsch & Gendron, 2011). In addition to the audit profession, international regulators such as the EC, IOSCO and the World Bank have managed to gain crucial influence. The nature of the interlocking relationships between those regulators, the big audit firms and IFAC are pointed out as useful to study for understanding developments within international audit regulation (Humphrey & Loft, 2012). What has not been done in the earlier research but makes this study relevant, is that this thesis studies these actors and their relationships with the aim of contributing to an understanding of how a particular standard setting case is influenced. In addition, this thesis contributes by investigating the potential influence on the standard setting process of other stakeholder groups than the international regulators and the big audit firms, such as investors, preparers, national standard setters and others.

The standard setting case that is in focus of this thesis is the changing of the standard audit report. The issue of improving audit reporting has become the most important and prioritized issue of IFAC's standard setting board IAASB (IFAC, 2014a). Thus while earlier research has focused on IFAC and the embedded organizations and their role in the financial infrastructure, this thesis studies the role of these actors and other stakeholder groups that are affected by and have an interest in the audit report development. This is studied to see if and how they have an influence on the approach taken by the IAASB.

By using the concept of regulatory space we add new understanding to the context around IFAC and IAASB and how the major and minor actors in this regulatory space contributes to the case

of audit report change, both in how it emerged as an issue and the way it develops. By not only studying the changing process alone, we concur with requests for looking at auditing with in its context in the international financial architecture (Humphrey, Loft & Woods, 2009).

#### **1.4 Delimitations**

The scope of this thesis involves IAASB's process of changing its standard unqualified audit report as dealt with in ISA 700 "Forming an Opinion and Reporting on Financial Statements" which subsequently involves a new additional standard – ISA 701 "Communicating Key Audit Matters in the Independent Auditor's Report". When addressing the second research question, a focus on the development of the new proposed section of Key Audit Matters is made. The mentioned two standards are also the main focus of the IAASB in its project to improve auditor reporting. Studying this process includes looking at involvement and interests of other actors, however not all actors within the regulatory space can be covered. This thesis focuses on the international organizations that are part of IFAC's and IAASB's formal governance structure as well as sample of respondents to the IAASB's audit report consultation process.

Also time limitations apply to the scope of this thesis. In order to provide a basis for IFAC's role in the global audit arena and the construction of this regulatory space in which we put IFAC in the center, we provide an historical perspective from the time when IFAC was established. However focus is primarily on the time period after the turn of the century, which started with corporate scandals that triggered criticism of auditors and later involved a global finance crisis that also put pressure for audit change.

## 1.5 Structure of the Thesis

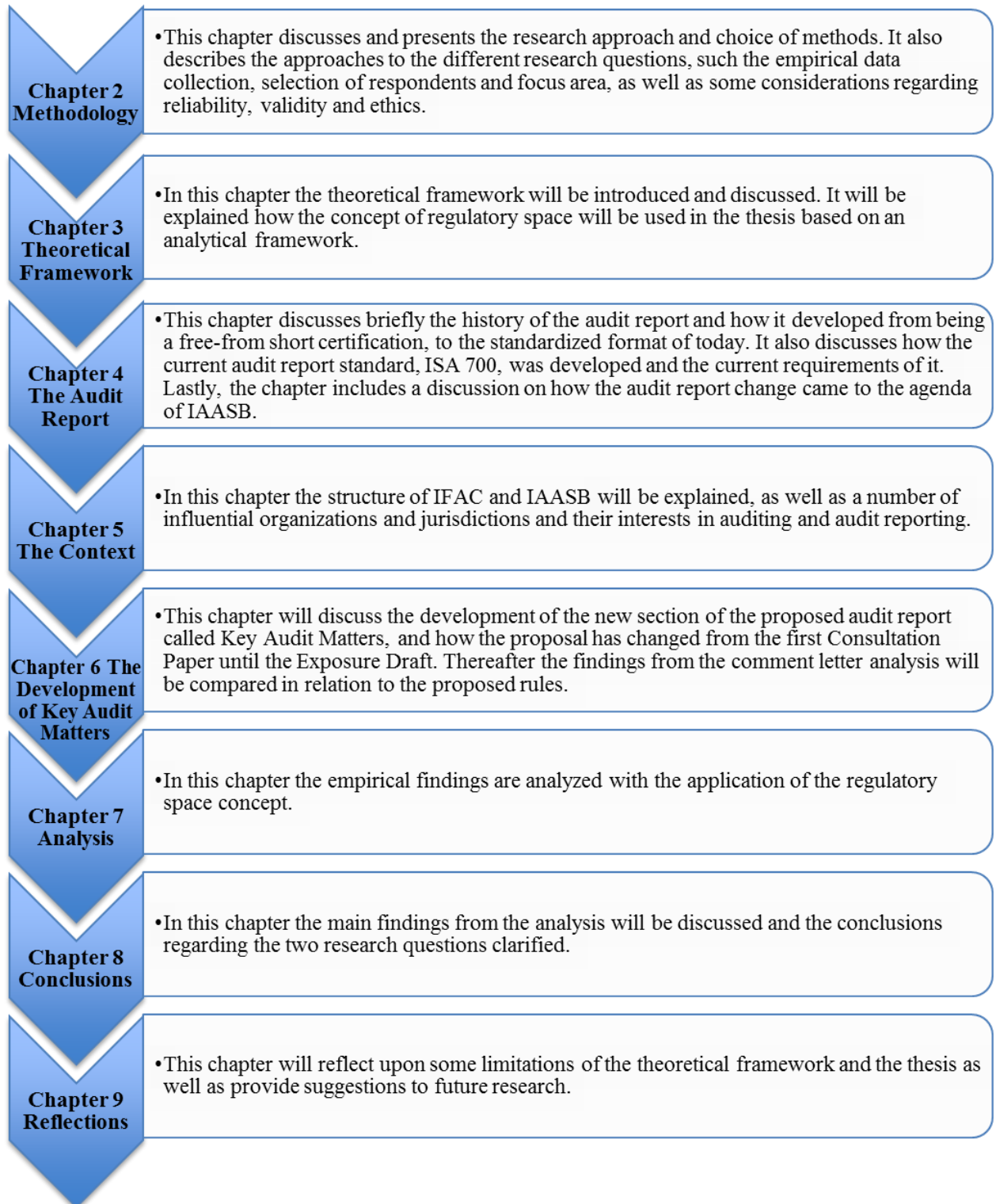

## **2. Methodology**

*In this chapter the overall research approach and methods are explained. The approaches to data gathering and selection of focus area and comment letter respondents are described in more detail, as well as some issues regarding ethics, reliability and validity.*

---

### **2.1 Approach to Research**

To fulfill the purpose of this thesis, which is to provide an understanding of the political process of changing the audit report standard, a generally qualitative research approach has been taken, which for instance means that we try to look for patterns and explanations in the empirical data (Bryman & Bell, 2011). Qualitative research often implies the need for understanding the context around the object of the research, as well recognizing processes over time in that for instance an organization's history influences the way that the organization is today (Bryman & Bell, 2013). This aligns with the purpose of our thesis and our choice of theoretical framework which also emphasizes the need for understanding regulation in its context of political and legal settings, participating actors and historical timing (Hancher & Moran, 1989). As opposed to quantitative research where looking for prediction and generalization of findings is usual, qualitative research, like the approach of this thesis, seeks illumination and understanding (Golafshani, 2003).

Our research process started with establishing the governance structure around IFAC and IAASB and subsequently identifying major actors and their interest and involvement in audit regulation in general as well as the specific case of the audit report. To be able to understand the audit report change of IAASB and the possible involvement of actors, the emergence and development of the current audit report was considered. All this provided a basis for addressing the second research question of investigating if certain actors are more successful than others in influencing the rules to the audit report. In approaching this question, a form of content analysis of comment letters was conducted. The comment letters were compared to IAASB's proposals to see which actors got their views incorporated into IAASB's proposed rules or not. A more thorough discussion on the process of addressing the two research questions is presented further in this chapter.

In addressing the two research questions we performed document analysis of official textual documents of both primary and secondary sources. These we understand as constructed in a certain contexts, by certain persons and organizations that have certain purposes with these documents. This is particularly relevant to for instance meeting minutes of organizations and the comment letters that were submitted to IAASB during its consultation processes (Mason, 2002). Comment letters can be seen as primary sources, since what we want to study is the public opinions and discussions of a particular respondent, to which the comment letter is a primary

source. Reports from organizations and journal articles can be considered as secondary sources, since they summarize and analyze the discussion of others (IUB, 2010).

Through the work on this thesis, our roles as researchers have been “outsiders” (Ryan, Scapens & Theobald, 2002, p. 152). This implies that we only used secondary data that is publicly available, such as published journal articles, meeting minutes, reports, comment letters and web site information, which put us distant from our study object. However as we read, understand and interpret documents such as comment letters, it cannot be avoided that we as researchers also are a small part of the construction. (Mason, 2002). We have chosen not to collect primary data, through for instance conducting interviews or surveys (IWH, 2008), for a number of reasons. One of them is that the object of our study is a very transparent process and therefore the information needed was already available to us. As the research process progressed we sometimes thought it would be interesting to ask some follow up questions to for example some of the major organizations surrounding IAASB or ask IAASB about their perception of the major actors we identified. However, due to time constraints this was not suiting, and further it was not of vital importance for continued research since we focused on formal influence rather than informal.

In our research we used qualitative data, which in addition to examining a limited number of comment letters means that we only draw conclusions on these respondents that we have studied. (Rienecker & Stray Jorgensen, 2011) Something that differ qualitative and quantitative data is that a quantitative analysis is always made after all data has been collected. Qualitative analysis on the other hand, can be characterized by interaction between data gathering and analysis (Bryman& Bell, 2013). This was also part of the process in which this thesis has emerged. After some of the data had been collected, we started analyzing, even if just in thought, and this in turn affected the next steps in data gathering. This means that our strategy for analysis is iterative in nature (Bryman& Bell, 2013). This was particularly relevant for the comment letter analysis, where the codification and information collection was refined along the way.

## **2.2 Connection between Theory, Analysis and Data**

We use our chosen theoretical framework as guidance for how to approach the purpose of the thesis, by adopting a wide lens for studying the regulatory space while at the same time focusing on the relationships of dominant organizations, as the concept suggests (Hancher & Moran, 1989). We also apply the concept of the regulatory space in the analysis in order to make sense of and explain our empirical data. The data was gathered from both a form of content analysis of comment letters and a document study of various research studies, reports, meeting minutes and website information.

### **2.3 Approach to Research Question 1**

To address the first research question we needed to establish boundaries for which actors, considered major, that we would focus upon. Our first step was establishing the structure around IAASB and IFAC. In this structure, the members of the IFAC's Monitoring Group, i.e. BCBS, the EC, FSB, IAIS, IFIAR, IOSCO and the World Bank, as well as the large international networks of audit firms have important roles. These are also the actors that are titled as key players within audit regulation or as parts of influential groupings useful to focus research on (Humphrey, Loft & Woods, 2009; Humphrey & Loft, 2012). Therefore these organizations and their interest in international audit regulation as well as the current audit report change are discussed more in depth than others. While researching on these organizations, important connections to the US were found. Because of that, and due to the simultaneous audit report changing projects in the US and by the EC, the audit report discussions in these jurisdictions are also highlighted. From earlier research on the regulatory space it is mentioned how regulation at one place is influenced by happenings elsewhere and therefore it is important to consider the parallel audit report changes (Young, 1994). While focusing on these organizations and jurisdictions, we do not aim to exclude other organizations or imply that all others are irrelevant.

#### ***2.3.1 Data Collection to Research Question 1***

While collecting information about these organizations, we (1) searched their website for information about auditing or audit reports, (2) searched via Business Source Complete and Google with search words like the "organization name + audit", (3) established if the organization had submitted any comment letters to the IAASB proposals on new audit report rules or/ and, (4) searched through IAASB's meeting material to learn if the organization engages in other outreach activities with IAASB. This data collection was an ongoing process throughout the work with the thesis. Due to this, and also with assistance from Humphrey and Lofts earlier research, we obtained a picture of the organizations' overall interest or involvement in auditing and audit reporting and discussed such recent information.

Meeting minutes and meeting material regarding the audit report from IAASB's website from 2009-2014 have also been read, to investigate which stakeholders they say they listen to or take input from other than from the comment letters. This helped us grasp the width of IAASB's outreach activities. All sources used are secondary and mainly consist of journal articles on the above mentioned research, the organization's web site information and reports or other type of documents published by the main organizations.

### **2.4 Approach to Research Question 2**

To address the second research question, which asks if it is possible to see whether some actors are more successful than others in influencing the rules to the new audit report, we analyzed responses to IAASB's proposals for change in form of comment letters. The IAASB asked for feedback and comments in this way at three occasions: to their Consultation Paper (CP) in 2011,



to their Invitation to Comment (ITC) in 2012 and to their Exposure Draft (ED) in 2013, as illustrated in Figure 1. Our analysis of interests in regards to this research question is therefore also limited to the content of these comment letters and to the actors that used this opportunity to respond to IAASB. The research of the comment letters is limited to the ones submitted to the CP and the ITC because the time frame of the thesis is from the CP to the suggested ED. Even if it would be interesting to see the responses to the ED it does not contribute to the thesis, as it is not possible to see if these are incorporated since the final standard is not decided upon yet.

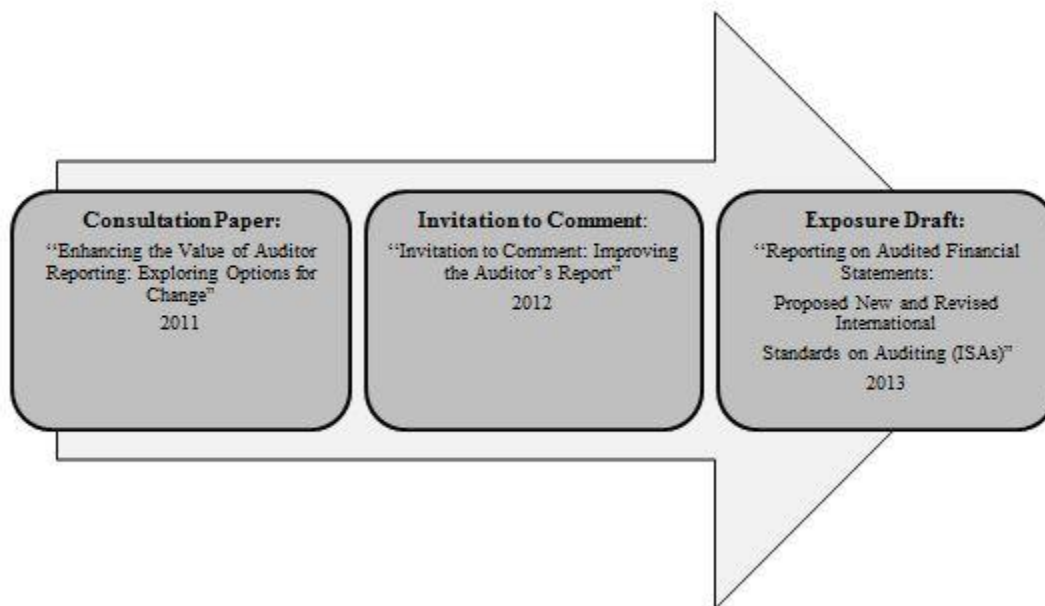

Figure 1: The Different Consultation Papers

We do not look at all interactions between IAASB and the different actors within the regulatory space, but limit the empirical data to the submission of comment letters. However, as explained before, some key actors in the governance structure of IFAC are discussed more in detail. Limitations with just considering comment letters for other stakeholder groups are that other possibly important factors that might influence the regulatory space related to the change of the audit report are missed. A consequence of this is that it might be difficult to say which actors being included and excluded in this space. Examples of relevant events that could be missed are formal and informal meetings and conversations between IAASB and its stakeholders. Both the organizations we identify as key actors and the other actors that are responding with comment letters could have significant importance in the process that we might exclude.

Earlier research has however shown that submissions to exposure drafts are an important part for different stakeholders to raise their voices. Submissions on exposure drafts are the most visible form of lobbying and it is highlighted that responding to exposure drafts “...provide respondents with a means of influence and persuasion” (Stenka & Taylor, 2011, p.110; Tutticci, Dunstan and Holmes, 1994). Tutticci, Dunstan and Holmes (1994) analyzed submissions to an exposure draft

by the Australian Accounting Standard setter to give an understanding of the Australian standard setting process. The authors point out that in the due process of standard setting lobbying is an integral part and could either be through formal or informal channels. Submissions to and membership of the standard-setting board are examples of formal lobbying while the informal could include telephone conversations and other more daily conversations. Obtaining evidence from the formal lobbying activities is easier than the informal and many earlier studies on lobbying have therefore focused on the submissions to exposure drafts (Tutticci, Dunstan & Holmes, 1994). Comment letters are a formal, and therefore visible, lobbying activity for stakeholder's interest and therefore considered relevant in this thesis to understand how different actors try to occupy the regulatory space of the standard setting process of IAASB.

#### ***2.4.1 Selection of Focus Area***

The proposed changes to the current audit report included both changes to the format, wording and new elements, such as the sections of Key Audit Matter, Going Concern and the Engagement Partner's name. Among the different proposals in the development of the new audit report, ISA 701 "Communicating Key Audit Matters in the Independent Auditor's Report" is considered to be the most relevant and significant change to the new audit report. IAASB pointed out that "the communication of key audit matters in accordance with proposed ISA 701 represents a particularly significant change in practice" (IAASB, 2013, p. 10). Before the final decision to focus on investigating just opinions regarding Key Audit Matters other proposals were also considered. The new Going Concern section is also much debated, but rather due to its connection to IFRS and the preparing of financial statements. We do not consider the Going Concern commentary as such a dramatic change to audit practice as the new section of Key Audit Matters. Because the different proposals and standards are complex and very detailed it was been considered that one focus area is more beneficial for our analysis. In the first phase of this thesis several comment letters were read in order to achieve an overview over the most relevant discussions. The introduction of an expanded audit report with an additional audit commentary was one of the most discussed matters with different opinions and therefore seen as an interesting choice of focus area.

Limitations with the focused investigation are that some aspects of the change of the content in the audit report will be left out, and therefore some influencing actors might not be noticed. Or the opposite, some of the respondents that seem to be influential might not be that in other areas. Still, we argue that investigating one area as the regulatory issue contributes to an understanding of and illustrate how some actors "get their way" and some are left out, which could be indicative of how these actors influenced the whole audit report change. At least it would provide a picture of who or which groups were active and successful in trying to influence the regulatory space when it comes to developing a significant change in auditing practice, e.g. the new requirement of Key Audit Matters.

### **2.4.2 Content Analysis**

To analyze comment letters we use a form of content analysis based approach. Content analysis has been described as a “research method that uses a set of procedures to make valid inferences from text. These inferences are about the sender(s) of the message, the message itself, or the audience of the message” (cited in Maglio, 2011, p.4). Many prior researchers studying comment letters to standard drafts use different kinds of content analysis (Yen, Hirst & Hopkins, 2007; Tutticci, Dunstan & Holmes, 2004). An advantage with content analysis is that it enables research by organizing texts into convenient parts. However, a disadvantage is that it is time consuming to create a coding system that makes sure that the research is reliable and reproducible (Yen, Hirst & Hopkins, 2007). We have experienced both these characteristics when analyzing the comment letters.

According to Smith and Taffler (2000) and Yen, Hirst and Hopkins (2007) there are two common kinds of approaches to content analysis. One is a quantitative analysis also called “form oriented” and that consists of routinely counting words or references. The other form is a “meaning oriented” or qualitative analysis that involves analyzing underlying themes and meanings in the text. The first form has the benefit of being more objective, while the second has the benefit of enabling deeper and fuller understanding of the analyzed text (Yen, Hirst and Hopkins, 2007). As a form of content analysis, we focused on the manifest meaning while reading the comment letters, thereby being close to the former kind of approach. This means that we concentrated on the literal meaning of the respondents’ arguments as opposed to trying to interpret hidden meanings. However we recognize that it may not be possible to find only the literal meaning, since the researcher influences with the own interpretation and the way that it is read (Mason, 2002, p. 149).

Our overall approach when analyzing comment letters was first to gain a deep understanding of IAASB’s proposals in the CP, ITC and ED that represent the different stages of the consultation process. While subsequently reading comment letters, we tried to identify aspects that the respondents promoted, which were not incorporated into the next proposal by IAASB, or matters which the respondents promoted which were later incorporated in IAASB’s next proposal. The categories in which we coded the responses were determined after reading a sample of comment letters, and were slightly modified if needed during the process. Thereby our approach to content analysis is not only similar to the quantitative explained above. The five overall questions we sought to answer by reading comment letters are provided in Appendix 1. The compilation was made in an Excel spreadsheet and to each question we also added a commentary section, to include the respondent’s argument for the matter in question. The length of the individual comment letters varied from one page to 44 pages, which suggests that the amount of issues and the depth of issues discussed, varies greatly between respondents.

A more quantitative approach to content analysis could possibly also have suited this thesis. However, we chose a more qualitative approach after making a pilot test of analyzing comment letters, in which we found that the ambiguity of answers and issues needed to be interpreted with a more holistic and contextual understanding and also by sometimes forming an understanding of both the CP and ITC comment letter submitted by the same organization. In addition, it is not primarily the aim of this comment letter analysis to generalize the findings to the whole population of respondents, but rather to analyze the possible influence of individual or small group of actors.

### ***2.4.3 Selection of Respondents***

As the number of comment letters was very high, 82 to the CP and 165 to the ITC, we decided to limit our analysis to a smaller amount of responses. All comment letters are available from IFAC's website (IFAC, 2014b; IFAC 2014c) When choosing a sample it also means that another selection could have been done and therefore is it important to consider if the choice of sample is relevant for the research question. The sample and selections reflect important strategic choices for the researcher to be able to answer the research question (Mason, 2002). This has been considered in the choice of our respondents. We believe that looking at a smaller number of respondents has some benefits, such as enabling analysis on an actor level and a more in-depth consideration of views. It would certainly be interesting to include all respondents' views and compare to IAASB's proposals to see which actors or arguments are incorporated. However, since we don't primarily aim to investigate if the respondents categorized in the same stakeholder group hold the same views for a generalizable purpose we believe that our selection, described more below, will nonetheless illustrate an interesting picture and fulfil our purpose and research question.

While doing the selection, a representative sample was sought while at the same time not wanting to exclude actors that the literature review and context research had suggested as important or influential, e.g. respondents from certain organization or countries. The selection of the respondents to IAASB's CP and ITC was therefore made in several steps. First, a categorization of respondents was adopted from IAASB who sorted in respondents in 10 main groups<sup>1</sup>. This sorting was primarily made in order to ensure that our selection consists of respondents from different kinds of stakeholders, with different missions and perhaps different interests to look after. This is considered important for analyzing participating actors in the regulatory space. Among the different stated stakeholder groups from IAASB two were excluded in the selection, namely Academics and Individuals. These two groups were considered at the beginning of our research but since it is stated from earlier studies on regulatory space that individuals, if not associated with an organization, seldom occupy the space it was decided to not

---

<sup>1</sup> Investors and Analysts, Those Charge With Governance, Regulators and Oversight Authorities, National Auditing Standard Setters, Accounting Firms, Public Sector Organizations, Preparers of Financial Statements, Member Bodies and Other Professional Organizations, Academics, Individuals and Others.

include these (Hancher & Moran, 1989; Young, 1994). It would possibly be interesting to test if these stakeholders are influence in this particular regulatory space, but because of limited time it was decided to focus on the multiple types of organizations and associations instead.

Since not all the respondents submitted comment letters to both CP and ITC the selection was based on the respondents from ITC. In the ITC the Auditor Commentary was developed to a relatively more specific concept and it was therefore considered to be the most appropriate basis for selecting respondents. The selection of respondents to the ITC was based on both a conscious choice and a random selection. The conscious choice was first based on key players that are described in section 2.3 in this chapter. It was also noticed that while investigating the context around IAASB and parallel audit report changes in the world, that the UK recently changed their audit report standard and that the US and the EC has the audit report on their agenda. To avoid the risk of excluding actors from these jurisdictions through a completely random selection, a second conscious choice was made. This was made from actors that we wanted to include in our analysis, due to their size or their connection to a large country. These were European Securities and Markets Authority (ESMA), Financial Reporting Council – UK (UK FRC), Fédération des Experts Comptables Européens (FEE), Institut der Wirtschaftsprüfer (IDW), Association of Chartered Certified Accountants (ACCA), Institute of Chartered Accountants in England and Wales (ICAEW) and Center for Audit Quality (CAQ). The rest of our respondents were a random sample where we made sure to include respondents from each stakeholder group. An overview over the selected respondents is shown in Appendix 2, where the identified key players are made bold and the respondents from the second conscious sample are marked with an asterisk. In total, 41 respondents were chosen, and due to that all of them did not answer to both CP and ITC it was a total of 68 comments letters in this thesis sample.

#### ***2.4.4 Empirical Presentation***

In the empirical section 6.5, we chose to highlight the views of certain stakeholder groups. Investors and analysts as well as preparers were chosen due to (1) them being part in the financial reporting supply chain (IFAC, 2014d), (2) they having relatively uniform views within the groups, and very opposing views between the groups. The Big Four audit firms and the regulators and oversight bodies were highlighted since they were in the previous empirical chapter identified as the key, powerful players in the audit regulatory arena, as well as part of the IFAC structure. The other actors are not highlighted as part of their initial category, but individually when views to selected issues are presented.

#### **2.5 Reliability and Validity**

The external reliability stands for whether or not and to which degree a study can be replicated. This criterion has been considered difficult to reach within a qualitative research due to qualitative research's study of social settings (Bryman & Bell, 2011). When it comes to the external reliability it is important to consider the possibility for an independent researcher to find the same conclusions in the same or similar context. The internal reliability stands for whether

another independent researcher that would be given the same generated constructs and data would have used them in the same way as we have done in this thesis (Thyer, 2001). To increase both the external and internal reliability in this thesis, we aim to describe as explicit as possible how we used the theoretical framework of regulatory space, how our empirical data was gathered and how selections were made. One way to increase the reliability in the qualitative research and decrease the inherent risk of judgment errors is to do cross-checking (Thyer, 2001). Since the coding process of the comment letters and how we interpret the responses was considered to be most crucial for the reliability, the cross-checking method was used. The analysis process involved that both of us separately interpreted comment letters. Therefore after a certain stages we compared our results and evaluated our methods to be able to make a more reliable evaluation and interpretation of the respondents' opinions.

The concept of validity within the qualitative research could also be explained by the degree of credibility and therefore focus on the truthfulness of the study. To reach an internal validity it is important that the researchers' observations and measurements give a truthful picture of reality. The researcher need to consider if what has been observed or measured is consistent with what the researcher believe it is observing and measuring (Thyer, 2011). The internal validity to the first research question is considered to be rather high. This is due to that the empirical data builds upon a rather systematic examination of data from both the investigated organizations view and what other researchers have concluded regarding the position of these organizations in the international financial infrastructure. The truthfulness is also considered high due to transparency of processes and how relationships were possible to follow through several available documents from different sources.

The internal validity in the second research questions was more critical with the risk of researcher biases (Thyer, 2011). It is possible that the first question and the findings affected the way we interpreted the comment letters of the identified main actors. When it comes to the external validity is it also seen as higher related to the first question and even if we study a specific process, the audit report change, the conclusions on major actors and their involvement are considered to be rather generalizable to other settings, such as other standard setting processes of IAASB. Since the analysis of data for the second question was very dependent on the sample it is not considered being appropriate to generalize the findings to other social settings.

## **2.6 Ethical Considerations**

When conducting research, ethical considerations are important to reflect upon (Bryman & Bell, 2013). Main considerations are usually relevant when using individual persons in the research and how these are approached and treated during the research and in the report. However this is not so relevant for our research, which is based solely on data that is publicly available and that also was produced with the knowledge and the purpose of being publicly available, such as reports, comment letters and meeting minutes. As a part of our ethical considerations, we instead

had a certain approach when reading comment letters to try and answer our predetermined questions. This involved not merely searching for key words in the responses, but to read the responses thoroughly to gain a holistic and overall understanding of the views presented, in order to not take a statement out of its context.

## **2.7 Chapter Summary**

This chapter has discussed the qualitative research approach of this thesis and how the research questions have been addressed by a document analysis of both primary and secondary sources. The choices regarding methods, selection of focus area, selection of comment letter respondents as well as advantages and disadvantages with content analysis have been presented. Our reflections and measures regarding reliability, validity and ethics have also been presented briefly.

### **3. Theoretical Framework**

*This chapter presents the choice of theoretical framework, namely the concept of regulatory space. The concept is introduced and an explanation of how it is applied in this thesis is given. It will subsequently be presented how the concept is used in some earlier research studies. Based on these studies an analytical framework is developed.*

---

#### **3.1 The Concept of Regulatory Space**

The regulatory space metaphor is used by several authors in their research (for example Hancher & Moran, 1989; Young, 1994; Canning & O'Dwyer, 2013; Jonnergård 2012; McDonald & Richardson, 2004; Jonnergård & Larsson, 2007) to get a wider understanding of the actors within a regulation process and their interaction and position of power. The concept was developed by Hancher and Moran (1989) as a result of making sense to existing findings in the area of economic regulation and to provide a new framework to understand regulation.

In this study, we explore the auditing regulatory space at what can be called the “societal level”, where the subjects of public regulation are audit firms and where the public interest in regulation lies with believing audits are important for the financial markets (Jonnergård, 2012, p. 53). Regulatory spaces of today are described as having rather delicate negotiated borders, which are influenced by a variety of interests and players (Malsch & Gendron, 2011). The concept of regulatory space is said to be “particularly appropriate for examining changes or renegotiations of rules within an existing regulatory arena“, which this thesis does by focusing on changes to rules of auditor reporting at the international level (Canning & O'Dwyer, 2013, p. 172). It can also be used to study regulatory processes and how regulatory space is constructed and reconstructed through time, with the entrance and exit of different actors (MacDonald & Richardson, 2004).

#### **3.2 Use of Theory**

For this thesis, the chosen theoretical framework of regulatory space provides guidance on how to approach the change of the audit report, by suggesting looking at the actors, their motivations for involvement, interactions and relationships between private and public organizations. To make sense of our empirical material of the major actors surrounding IAASB, this audit report change and how it has emerged, which involves multiple actors with different missions, we apply the concept of regulatory space in our analysis. Doing this enables us to think of the actors as competing forces for space and power, and draw conclusions on which the possibly influential actors are within this space. The regulatory space metaphor hence gives the terms and expressions that can help explain the interaction, relationships and activities found in the empirical data. However, as Young (1994) mention, interests of actors is not the only thing that explains the actions of them, and just because they are members of a specific category doesn't mean that they automatically have the interest of that category. Interests are rather constructed



and reconstructed depending on the situation. In this thesis, audit report change is seen as happening in a space constructed by organizations and actors that attempt to influence audit regulation

### **3.3 Regulatory Space as defined by Hancher and Moran**

Hancher and Moran (1989, p.271) focused on the economic regulation under advanced capitalism and mapped out some distinctive features to explain how the character of regulatory activity was shaped to further suggest that regulation could be best understood by using the concept of regulatory space. The regulatory space “...is defined by the range of regulatory issues subject to public decision” (Hancher & Moran, 1989, p. 277) and among the features that influence the shape of the regulatory space and how the power is distributed, are national political, and legal setting, organizational structure, historical timing, the character of markets and the nature of issue arenas explained (Hancher & Moran, 1989).

Regulation could be understood by seeing it in the context of being a defining feature of any system of social organization, thus the existence of a social order is characterized by the presence of rules as well as the attempt to enforce those. Some core activities are constant in the process of regulation and according to Hancher and Moran it “involves the design of general rules, the creation of institutions responsible for their implementation, the clarification of the exact meaning of a general rule in particular circumstances and the enforcement of the rule in those circumstances” (1989, p.271). In the space there is a constantly forming and reforming with change of allocation of roles between rule makers, enforcers and bearers of specific interests and no public-private divide is made Hancher and Moran (1989, p. 276). This in turn leads to that the economic regulation under advanced capitalism is best seen from the perspective of a sphere with activities where the public and private are mixed and dominated by powerful actors. To understand the nature of activities that occurs in economic regulation, one need to consider who participates in and benefits from regulation as well as the relationships to be able to understand the regulation activities. (Hancher & Moran, 1989)

The authors point out some consequences of the use of the concept of regulatory space. For instance, since it is a space, it is available for occupation and can be unevenly divided between actors, suggesting there will be more significant and less significant occupants. The regulatory space includes a variety of regulatory issues where its occupants struggle for their benefits. To get a deeper understanding of the concept these struggles could be examined to understand the interaction and distribution of the power within the regulation process. However, the authors also point out that examining who has power in the regulation process by studying the relations within the space leads to another important aspect, namely that in the process there are also actors that are excluded (Hancher & Moran, 1989).

According to Hancher and Moran (1989), understanding who is inside and who is outside is a vital process and could be done by examining how the organizational relationships look in a specific regulatory space. Like various groups could be organized into or out of a regulatory space the same applies to various issues. What kind of issue that is in the regulatory space depends on what is seen as “regulatable” (Hancher & Moran, 1989, p.278), which in turn could be explained by factors such as history, culture, existing resources and the power relationships of the actors in the regulatory space. Also, to understand the current regulatory arrangements, it is crucial to be aware of the historical context in which it developed. Still, the factors that determine the shape of the space and how it is occupied are both many and complex.

Historical timing plays an important role in the regulatory space. First of all the timing reflects one basic feature of regulation as an activity. The activity of regulation needs to be organized and therefore there is also a need for proper institutional arrangement that in turn requires some resources. The organizations that control the right resources will be able to dominate the regulatory space and this combined with the initial historical moment of a change will give the organization a good opportunity to get a continuously dominant influence. Furthermore, the timing aspect symbolizes the nature of regulation where crises often result in a change or search for alternative institutional planning (Hancher & Moran, 1989).

Even if it is emphasized that the regulatory space is shaped by how regulation takes place in particular places and particular times there is another factor that Hancher and Moran (1989, p. 286) stress, namely how this space is dominated by organizations. Among these big organizations are the largest firms, representative associations, regulatory agencies and central departments of the state. The authors mean that economic regulation is basically regulation by and through organizations, and the activities of regulation will be affected by who or what exercises any power in the regulatory process. The importance of organizations is explained by the view of private citizens as “takers” of private regulation while the organizations are the makers and shapers. It is seldom that a private citizen succeeds to gain power within the regulatory space if not as a part of an organization. Regardless if the organizations that dominate the regulatory space are seen as private or public, some typical characteristics can be identified. In addition to that the organizations dominating the space often are big they also are characterized of highly structured internal division of administrative labor and administrative hierarchies. For a regulation to be completed within a regulatory space with dominating, large and hierarchical organizations there is a need for cooperation and therefore the regulation is practically never a result of a single individual or simple organization. The main point therefore, is that the most important relationships in economic regulation are the ones between the organizations. These important occupants in the regulatory space will be best understood through the view of their relations of exchange and interdependence (Hancher & Moran, 1989)

### **3.4 Young: “Outlining Regulatory Space...”**

Young (1994) uses the regulatory space perspective to explore the processes through which changes in financial accounting practices occur or fail to occur. Three different accounting issues were examined within the agenda of Financial Accounting Standards Board, FASB. The decisions of FASB are explained by Young to be embedded in social and historical contexts and accounting change is related to events taking place elsewhere. Further it is explained that FASB operates within a complex institutional nexus located between accounting profession and the state. Young use the regulatory space in her research as an abstract conceptual space to explain how changes in recognition and measurement practices of financial accounting occur. She sees the space as as constructed by people, organizations and events related to accounting and accounting practices. Further, it is in this space that the changing process of financial accounting practices takes place.

Young points out the advantages of the use of the regulatory space metaphor as that it recognizes the complexity of standards setting and agenda formation processes. The metaphor could be used as wide theoretical lens to focus upon the issues of agenda information and since the metaphor takes the approach of a space it also lead the researcher to the question; who is in this space and involved in the process? This lens leads to that the researcher need to widen the examination of the organizational boundaries of the standard-setter and take into account the roles of other actors. The lens clarifies that the FASB doesn't act in a vacuum but in a broader social and economic environment and in interaction with other actors and organizations in the regulatory space. Focus in the research of Young is also how the interests are seen as constructed and interpreted depending on the situation instead of interest being what defines actions of actors within the regulatory space. In the regulatory space these actors rather interpret, construct and reconstruct their interest while constructing problems, actions and solutions. Using the metaphor of regulatory space in the arena of accounting stressed the importance of investigating the actors and institutions that contribute to the processes of accounting change.

The conclusions that Young draws from her study is interesting to consider for this thesis study of IAASB's as a standard setter as well. The purpose was to study how the processes through which changes in three different accounting issues occur or fail to occur by the lens of the regulatory space. First of all, Young suggests that accounting problems are constructed by the occupants of the regulatory space and in this process not just the standard-setter, FASB, act alone in the construction phase. It was shown in all of the investigated accounting issues that the process of constructing accounting problems was related to the existence and interpretations of various actors in regulatory space. Issues arise when participants of the space construct them as problems, and are solved when FASB creates and “appropriate” solution. By using the regulatory space the existence of conflicting perspectives on the description of the accounting problems and adequate solutions was visible. It was shown that participation in the process was primarily by individuals associated with the largest public accounting firms, large manufacturing or service

companies, Congress or other public organizations. Similar to the statements of Hancher and Moran (1989), the individual actors, such as academics and the assumed users of financial statements, seldom occupy the regulatory space. The study also showed that the process of agenda formation includes interpretation by the standard-setter about what the participants in the regulatory space expect from them regarding the role and purpose of a standard setter. With her study Young shows that an understanding of accounting standard setting also requires an understanding of the role of accounting claims and expectations about standard setters that construct a regulatory space for accounting change.

### **3.5 Jonnergård and Larsson: “Developing Regulatory Space...”**

Jonnergård and Larsson (2007) studied the emergence of a Swedish corporate governance code in what can be seen as a new regulatory space. The focus in their investigation is on the debate concerning the proposal of a corporate governance code in the processes of referral. The debate was seen as lively and extensive where several issues have been discussed, such as the composition of the board and the transparency of the final accounting. By analyzing the comment letters to the exposure draft of the new code and comparing it to the final code, Jonnergård and Larsson were able to distinguish which groups of actors were most successful in their attempt to gain support for their views and opinions.

Jonnergård and Larsson mean that in analyzing and describing regulatory processes the concept of regulatory conversation and regulatory space offer new opportunities. The regulatory conversations, as conversational activities between organizations, interest groups and other actors outline the space. These conversations can be used to understand the definition of issues and how acceptable and appropriate solutions are reached. By the development of shared meanings, regulation and coordination can be reached and the regulatory space could be seen as the scene where the different issues and interest are voiced. One of their conclusions is that to understand the division of regulatory space and who is influential in the referral process, it is important to look at both the actors that initiate the conversation and the participants in it. They also view the regulatory space as a constructed space that changes as participating actors change and new regulation issues arise. At last, they conclude that the metaphors of regulatory space as well as the regulatory conversation are useful methodical tools that “help to account for regulatory changes in the background of internationalization” (Jonnergård & Larsson, 2007, p. 484).

### **3.6 Analytical Framework**

Below follows a summary of the main points and characteristics of the regulatory space concept that we gathered for the use in our thesis from the research of Hancher and Moran (1989), Young (1994) and Jonnergård and Larsson, (2007) as presented in this chapter. This constitutes our analytical framework, which we bore with us through the process of writing the thesis, and which provided a foundation for analyzing the case of IAASB’s audit report change.

The metaphor of regulatory space leads the researcher to the questions of who is inside the space and who is involved in the regulatory processes. It also leads the researcher to look beyond the organizational borders of the standard setter and examine roles of other actors. Regulatory space is available for occupation and therefore will be unevenly divided among major and minor actors. Both issues and actors can be included and excluded from the space. Features such as historical timing, organizational structures and political and legal settings affect the character of a particular regulatory space and how the power is distributed among actors within it. A crisis that interrupts the usual routine, often brings consequences of change to regulation or a request for different institutional structures, which is why historical timing is said to play an important role. In a space, a variety of issues regarding regulation is present, about which the participating actors struggle for their benefits. The struggles can be studied in order to understand the power distribution and interactions in a regulatory process. Submitting comment letters to a standard setter is here seen as one of these struggles and interactions, which has a special focus in this thesis.

The most important relationships are said to be the ones between organizations and for regulation to be accomplished there is almost always need for cooperation between organizations. To understand who is inside and who is outside the regulatory space, it is important to look at organizational relationships. Another important matter to explain is the scope of regulatory issues. In our case, the issue is the auditing standard concerning the auditor's report. Issues can be seen as constructed as problems by actors within the space, and the standard setter responds in a way it deems it appropriate, based on the expectations held by other participants of the space.

Regulatory conversations between different actors can also be seen as a feature that outlines the regulatory space. Such conversations can be analyzed to obtain an understanding of how appropriate solutions to issues are raised. To be able to draw conclusions about how the regulatory space is divided and who the influential actors are in a referral process, like IAASB's outreach, both the participants that initiate the conversation and participate in it are important to consider.

### **3.7 Chapter Summary**

This chapter includes a discussion of the concept of regulatory space as developed by Hancher and Moran and subsequently used by others in research relevant to this thesis. Through the analytical framework, key aspects of the regulatory space is summarized and it can be concluded that the concept of regulatory space focuses on the involvement of actors in regulatory processes and the relationships between the participating organizations. The concept is considered useful for studying changes to regulation in an already existing regulatory space. In the analysis in chapter 7, we return to the regulatory space concept for analyzing the empirical material.

#### **4. The Development of the Audit Report**

*As the concept of regulatory space suggests, identifying how regulatory arrangements have come to be in the past is important for understanding regulation today (Hancher & Moran, 1989) This chapter discusses briefly the history of the audit report and how it developed from being a free-from short certification, to the standardized format of today. It also discusses how the current audit report standard, ISA 700, was developed and the current requirements of it. Lastly, the chapter includes a discussion on how the audit report change came to the agenda of IAASB.*

---

##### **4.1 The Development of the Standard Audit Report**

As this section will illustrate, the format and content of the audit report has changed substantially over the last century, from being an individual description of the audit conducted for each engagement to now being a more standardized format containing uniform language (Weirich and Reinstein, 2014). A brief historical background to the audit report will be provided, mainly concerning the development in the US, as this was considered to be the main center of audit development between 1920 and the 1990s (Porter, Simon & Hatherly, 2008).

The name “auditor” comes from that the audit report first was provided as a detailed verbal report, before it later came to be in writing. The audit report was in the early 1900’s a nonstandardized report often called a certificate, where the auditor certified that accounts were for instance truthful or correct. It was not unusual that the report only consisted of just one or two sentences, or even of only the word “certified” (Jamal and Sunder, 2013, p. 38; Church, Davis and McCracken, 2008). This audit report came to the US from British influence, since the accounting profession was introduced in US by British professionals (Carmichael and Winters, 1986). Below is an example of a typical audit report from this time, given by Price Waterhouse & Co (cited in Carmichael & Winters, 1986, p.56):

*“We have examined the above accounts with the books and vouchers of the company, and find the same to be correct. We approve and certify that the above balance sheet correctly sets forth the position of the company.”*

There were also long-form audit reports which included information about for example audit procedures, how the auditor made judgments on valuations and the how they judged accounting methods to be appropriate. There were no official standards of accounting or auditing at this time in the US and therefore not much control over the quality of auditing and accounting. The economic turbulence in 1907 which harmed the reputation of large corporations is said to have created a favorable environment for regulation. The first recommended form of an audit report was then issued and after the US stock exchange crash in 1929 the audit report was standardized. The auditors also stopped using words such as certify, in order to to avoid stating that they give absolute assurance (Carmichael and Winters, 1986; Church, Davis and McCracken, 2008 ).

In 1948, the audit report as a pass/fail model similar to today's first came to be (Weirich & Reinstein, 2014). This means that the financial statements of an entity are either considered to be fairly presented or not and hence be seen as to pass or fail (ACAP, 2008). From 1948 to 1988 the standard audit report was changed several times, however the changes can be considered minor and mostly related to wording (Strawser, 1990; Church, Davis and McCracken, 2008).

There were further recommendations and pressures for changing the audit report, for instance due to unclear division of responsibilities between the auditor and the management. In 1988 ASB therefore established a new standard audit report with the aim of reducing the expectation gap. This audit report contained three paragraphs instead of two (Sumutka, 1989). This type of long form audit report introduced by AICPA was soon adopted also by IFAC and became standard by the beginning of the 1990s (Porter, Ó hÓgartaigh & Baskerville, 2009; Strawser, 1990).

#### **4.2 The Development and Current Requirements of ISA 700**

Taking the lead in global efforts of harmonizing audit reports, the IAPC (predecessor of IAASB) issued its first recommendation for the audit report in 1983. This International Audit Guideline (IAG) no. 13 was called "The Auditor's Report on Financial Statements" and was made with the aim of guiding auditors to the form and content of the audit report. This was believed to improve users' understanding of the report (Gangolly et al, 2002). To clarify the standard and to change the form of the audit report, it was revised in 1989 and again in 1993. The need for a new audit report was said to mainly come from the globalization of financial markets where the auditors more and more audited financial statements that were used for international financing (Roussey, 1996). The auditing standards of IAPC were very similar to the ones of AICPA in the US. An explanation for this could be the dominance of the large audit firms in both IAPC/IFAC and the standard setting board of AICPA (Wallage, 1993). After the revisions, two important elements the IAPC's standard required the audit report to include was: A clear auditor's opinion on the financial position and results of the entities' operations, as presented in the financial statements, and a statement of the responsibility of the management and the responsibility of the auditor (Gangolly, 2002; Pucheta & Fakhfakh, 2005). An overview of what the audit report was required to include as from 1994 is provided in Appendix 3. At this time the ISAs had been codified and the audit report ISA had received its current number, ISA 700 (Roussey, 1996).

After a minor revision in 2001, IAASB again in 2004 made a revision of its standard audit report. This time it strived to enhance consistency in auditor reporting between countries and to increase the users' understanding of the audit report and the auditor's role. To achieve these goals, IAASB thought the audit report should mandate which content the report should have while keeping it simple, short and succinct (IAASB meeting July 2003). During a Clarity Project of all ISAs, which was finished in 2008, the standards got new structures with clearer objectives,

requirements, definitions and explanatory material. The ISA 700 had now become what it is today (IFAC, 2014e).

Requirements regarding the audit report are stated in many ISAs but it is ISA 700 “Forming an Opinion and Reporting on Financial Statements” that contains the overall rules for the content and form of the audit report. The main elements of the audit report are summarized in Table 1 below. This can be a useful background to the rest of the thesis, which discusses requests for additional information and changes of these requirements. An illustrative audit report as it looks today is for the same reason provided in Appendix 4.

Particularly interesting given the focus of this thesis is the Emphasis of Matter paragraph that can be included when the auditor wants to draw the reader’s attention to matters in the financial statements that it considers “fundamental to the users’ understanding” of them. An Other Matters paragraph can similarly be provided when the auditor wished to draw attention to matters that are not disclosed in financial statements, but are considered relevant for users. More precisely, it is stated in ISA 706 “Emphasis of Matter Paragraphs and Other Matter Paragraphs in the Independent Auditor’s Report” that the auditor, when considered necessary, draws attention to:

*(a) A matter, although appropriately presented or disclosed in the financial statements, that is of such importance that it is fundamental to users’ understanding of the financial statements; or*

*(b) As appropriate, any other matter that is relevant to users’ understanding of the audit, the auditor’s responsibilities or the auditor’s report (ISA 706.4).*

**Elements in the audit report based on the current ISA 700      Summary of what each section includes:**

<b>Title</b>	The title should state that it is from an independent auditor.
<b>Addressee</b>	Who the report is addressed to, e.g. shareholders
<b>Introductory Paragraph</b>	E.g. the name of the audited entity, the title of the each section of the financial statements that are audited and the date or period covered by each statement
<b>Management’s Responsibility for the Financial Statements</b>	Explains the responsibilities of management or TCWG, i.e. those responsible for preparation of financial statements
<b>Auditor’s Responsibility</b>	Explains the responsibility of auditors and description of what an audit includes in term of risk assessment, auditor judgment in deciding the audit procedures, evaluation of appropriateness and reasonableness of the entities accounting policies and estimates. States if the auditor believes it has obtained sufficient appropriate audit evidence to make and



<b>Auditor's Opinion</b>	opinion.  This is the section where the auditor express its opinion about whether the financial statements “give a true and fair view” or “present fairly, in all material aspects” in accordance with the applicable financial reporting framework. One of these two expressions should be used for an unmodified opinion.
<b><i>‘Emphasis of Matter’ and ‘Other Matter’ paragraphs</i></b>	If auditor determines that it is necessary to draw attention to a matter in the financial statements that is “fundamental to the users’ understanding” of the financial statements, this is disclosed in an Emphasis of Matter paragraph. Similar in an Other Matter paragraph, matters <i>other</i> than those disclosed in the financial statements, that are “relevant” for users’ understanding, can be discussed.
<b>Other Reporting Responsibilities</b>	Other matters on which regulation, other than ISA, may require the auditor to report
<b>Signature of the Auditor</b>	Auditors should sign the audit report
<b>Date of the Auditor’s Report</b>	Not an earlier date than the date the auditor has obtained sufficient appropriate audit evidence to base its opinion on.
<b>Auditor’s Address</b>	States the location of the auditor’s practice.

Table 1: The Main Elements of Current ISA 700

### 4.3 How the change of the audit report came to the agenda

The current standard on audit reporting, ISA 700, was issued in 2008 as a revised version of the ISA 700 issued in 2004 (IFAC, 2014f). As the next chapter will partly present, there were at this time discussions on audit quality and an increasing request for auditors providing more insight into the audit of an entity’s financial statements. IAASB together with the AICPA’s ASB ordered studies to address the need of understanding user perceptions of the standard unqualified audit report. The purpose behind these four research studies was not to investigate whether a change to the standard unqualified audit report was necessary, or to include general and principal topics concerning audit communications but rather to obtain information about how various users perceive audit reports (IFAC, 2014f, p. 2). The reports included a finding that suggested that the audit report due to its standardized format and language is considered useful only to the extent of finding out if it is unqualified or qualified (Coram, Mock, Turner & Gray, 2011). Other findings were that there exists an expectation gap between users and auditors in for example the responsibilities of the auditor and also that some elements in the report are misunderstood by users, leading to a greater gap (Gold, Gronewold and Pott, 2012).

At the end of 2010, IAASB thought it had found enough evidence supporting that they should explore what changes can be done to audit reporting (IFAC, 2014g). Since for example IOSCO, EC, FRC and PCAOB, which will be discussed in the following chapter, had begun investigating ways of improving audit reporting and the role of the auditor, IAASB also joined to see how they could respond to the requests for change (IFAC, 2014h). The IAASB working group believed that before considering possible major changes to ISA 700, they would need more views from a broad range of stakeholders. Therefore a Consultation Paper (CP) was issued. IAASB (2011) explains as a background that as a response to the situation that the business environment has been facing recently, characterized by an increasingly global and complex development and global financing crises, the demand and need for the financial reporting has been emphasized. This demand includes the need of credible, high-quality financial reporting with more additional information about the entities as well as about the process around the quality of the financial reporting. To reduce the level of uncertainty connected to investment decisions existing shareholders, potential investors and others seek information that they believe is both relevant and reliable.

When developing CP, the working group of IAASB said it took different audit reporting models as well as practice in different countries into consideration. For example were UK, Germany and the US audit report models for enhancing the usefulness of the audit report reflected upon. The CP was also developed on the foundation of that the scope of the audit would remain unchanged (IFAC 2014i). In December 2011, the IAASB decided on a project proposal of changing the current ISA 700 and related standards, to make audit reporting more relevant and aligned with user needs. In doing so, IAASB claims they respond to current user demands for change and particularly strong demands from the US, UK and other countries in Europe. Other initiatives, such as from the EC and American PCAOB, to improve the audit report were seen as reasons for IAASB to put this on their agenda at the same time as well, thereby enabling joint efforts (IFAC, 2014j).

The main user need identified is the one of investors and an aim was to narrow the information gap. The information gap is explained as the gap between what information investors think they need to make decisions about the entity and the information that is publicly available to them through financial statements or otherwise (IAASB, 2011). The IAASB assigned to a Task Force to appropriately prioritize the needs of mainly investors and analysts but also consider other interest groups such as regulators and creditors. How this prioritization was later made is however not explicitly disclosed.

At the same time as considering the responses to the CP, IAASB emphasized the need of looking at the audit reporting suggestions of PCAOB and the EC, to show cooperation and to limit the alternatives for change (IFAC, 2014g). It was agreed that the IAASB in the case of audit reporting would go beyond its usual consultative process, and create additional opportunities for attaining input from the public (IFAC, 2014g). In the IAASB's June 2012 meeting was it decided that a consultation document named "Invitation to Comment: Improving the Auditor's Report" (ITC) would be approved and open for comments until October 2012.

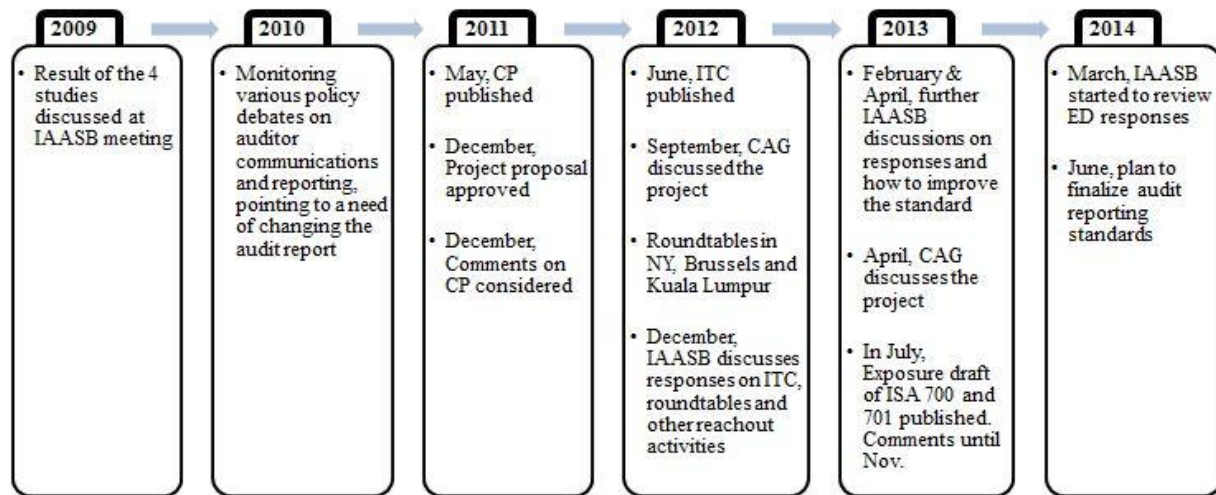

Figure 2: Overview of Audit Report Due Process

Figure 2 above is an overview over the due process to change the standard. The comment period for the Exposure Draft closed in November 2013 and the final draft is intended to be finished in 2014 and thereafter by the time of 2016 become applicable (IAASB, 2013).

#### 4.4 Chapter Summary

In this chapter the history of the audit report has been discussed where it has been shown that earlier crises or lack of confidence in the audit report has led to changes. The development of the ISA 700 and its current requirements has also been presented. Lastly an overview of how IAASB took the audit report change on its agenda was discussed, in where it can be seen that pressures from different directions played a great role. The next chapter will introduce and outline the structure of IFAC and IAASB and discuss other relevant actors within audit regulation.

## **5. The Context**

*This chapter outlines the context and structure around the IAASB, a standard setting committee under IFAC. It is explained how IFAC and IAASB through support from important global organizations such as FSB, IOSCO and the World Bank, have positioned themselves as important players in the international auditing regulatory space. Further, a number of influential organizations and their interests in auditing and audit reporting are outlined. Since it is believed that audit regulation is not developed in an isolated context, a presentation of simultaneous regulatory activities within the EU and the US is made.*

---

### **5.1 The IFAC structure**

This first section outlines the governance structure of IFAC and how the three-tier structure of IFAC, its Monitoring Group and its Public Interest Oversight Board (PIOB) came to be. This section further presents IAASB's composition and due process standard setting in the light of various influential bodies.

#### **5.1.1 IFAC**

IFAC was founded in 1977 as a private organization by 63 national associations of professional accountants with the mission to strengthen the worldwide accountancy profession in the public interest. To achieve this goal IFAC was aiming to develop high-quality international standards in areas such as auditing and assurance, ethics and public sector accounting. Collaboration and cooperation projects was established both between the members of IFAC and with other international organizations with the goal for IFAC to be an international spokesperson for the accountancy profession. Since IFAC was established the amount of members has increased to 179 and IFAC now presents members from 130 countries and jurisdictions (IFAC, 2014k). Today, the members and associates are representing around 2.5 million accountants in various fields (IFAC, 2014l). The same year IFAC was founded, the organization also established several independent boards and committees to help them in the development of international standards and guidance and to focus on different sectors of the profession (IFAC, 2014k).

The vision of IFAC is that the global accountancy profession will be accepted as a respected leader in the development of strong and sustainable organizations, financial markets and economies. The mission from the foundation day still exists and IFAC works continuously to serve and protect the public interest by developing, promoting and enforcing high-quality, internationally recognized standards within the area of for example auditing. By its continuous work, the organization says it wants to contribute to give the different stakeholders an assurance of reliable information in the global economic development (IFAC, 2014l). To carry out the stated mission with the standard setting in the public interest, IFAC established the IAASB to function as an independent standard-setting body under IFAC.

Loft, Humphrey and Turley (2006) argue that IFAC, through support from powerful organizations such as EC, the World Bank, IOSCO and Financial Stability Forum (now Financial Stability Board, FSB) has succeeded in positioning itself in an important place in what is called the “new international financial architecture”. A significant achievement was when WTO in 1997 formally acknowledged IFAC as the international standard setter for the profession of accountants (World Trade Organisation supports IASC standards, 1997). Around the same time, the EC showed interest in the ISAs and implied that ISAs could be subject of implementation in the EU countries at a later stage (EC, 1996).

### ***5.1.2 The Three-tier Structure of IFAC, PIOB and the Monitoring Group***

It was in 2005 after several corporate scandals, such as Enron in 2001, WorldCom in 2002 in the US (Foster, 2010) and Parmalat in 2003 (World Finance, 2003) in Europe, that PIOB was created as a response to the mistrust in the financial information and in the credibility of audit opinions. In this era, quality and integrity of financial information was proven to be important factors for confidence in markets and for financial stability. The corporate scandals revealed the need for high quality international accounting and audit standards to improve the financial reporting around the world. The audit profession was commonly blamed for these scandals and the mistrust in the financial information lead to a financial instability (PIOB, n.d.1). This led to new contact and communication between the IFAC, the big audit firms and international regulators, whose interests started to interlock (Humphrey, Loft & Woods, 2009).

In the beginning of 2003, it was decided that the top priorities for IFAC consisted of setting high-quality standards and achieving international support and use of ISAs. A meeting with representatives of the international regulators IOSCO, the EC, the World Bank, the BCBS and the IAIS put pressure on IFAC to improve international auditing and having the IAASB overseen by an independent public interest body (Humphrey & Loft. 2009). These mentioned regulators founded later the Monitoring Group over IFAC. The Monitoring Group and IFAC decided on a plan to reform the standards-setting and compliance activities of IFAC. At this time it was criticized that the audit profession itself was setting its own rules and the aim of the reform was to improve both the standards governing the audit and the way they were drafted. In addition to this, the reform aimed to ensure that the IFAC served the public interest to be able to gain back trust regarding the audit profession and the audit reports (PIOB, n.d.1). The new reform thus lead to that PIOB was created as an independent body from the profession to oversee the governance and activities of the standard-setting bodies of IFAC, which includes IAASB. Questions were however raised about which public interest PIOB members would represent and if it could go beyond the interest of the global institutions it relied upon (Loft, Humphrey & Turley, 2005).

The global standard-setting in auditing hence consists of a three-tier structure of standard setting boards of IFAC, such as IAASB, independent oversight by PIOB and accountability to the authorities of the Monitoring Group (PIOB, n.d.2). This structure is shown in the picture below, together with for example the IFAC Regulatory Liaison Group (IRLG), which consists of e.g. the

leadership of IFAC, the head of Forum of Firms and six other nominated by the Global Public Policy Committee, all of which will be discussed further in this chapter. The IRLG works with the Monitoring Group regarding current audit regulation issues (IFAC, 2014m). The idea behind this model between the different organizations is that high quality global standards will be produced with help from the profession, but that the standards at the same time will be in response to the public interest. The original idea was to have an oversight body entirely independent of regulators and the accounting profession, but when PIOB was created its member mostly consisted of former regulators that were nominated by international regulatory organizations. Humphrey and Loft (2009) argue that regulators now have a crucial position of influence within IFAC and that IFAC can be seen as a place where the different interests of international regulators and others are pursued.

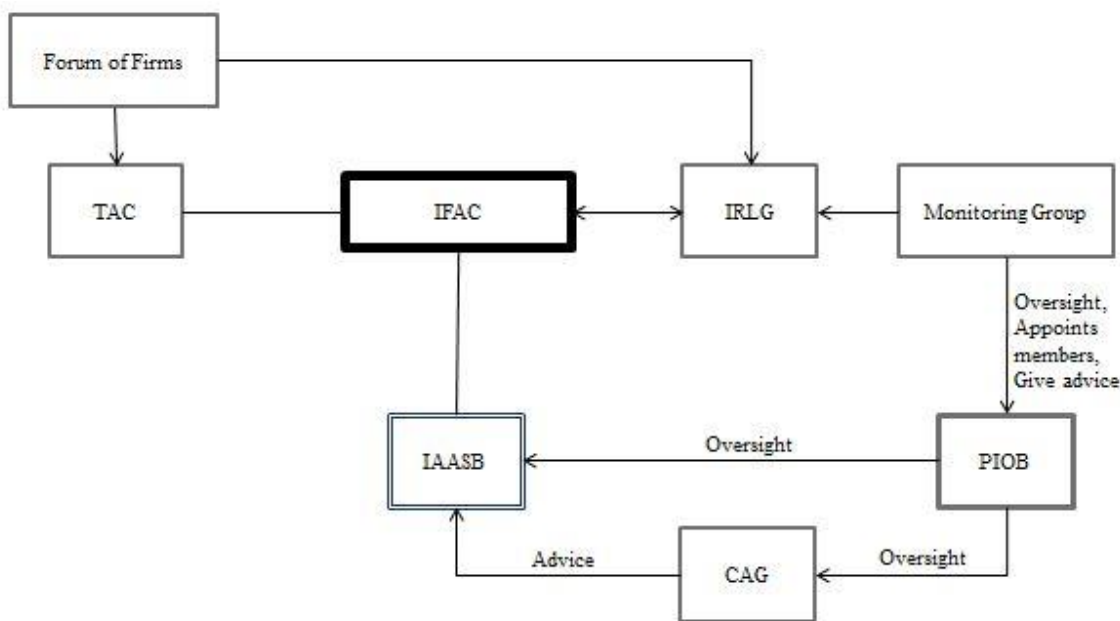

Figure 3. Main Structure of IAASB and IFAC  
 Source: (IFAC, 2014m.; PIOB, n.d.2)

The mission of the Monitoring Group is that it should cooperate in the interest of promoting high-quality international auditing and assurance, ethical and education standards for accountants. The Monitoring group works for the public interest in areas that are related to international audit standard setting and audit quality and consist of different international financial institutions and regulatory bodies. The Monitoring Group oversees the IFAC Reforms and their implementation processes and effectiveness and also other aspects of the work of IFAC that concern the public interest. Furthermore, the mission of the Monitoring Group includes appointing the members of PIOB; overseeing the implementation by the PIOB of its mandate; and to consult and advice the PIOB (IOSCO, 2014).

The PIOB in turn, with its function of a global independent oversight body, works to improve the quality of international standards from the standard setting boards within IFAC. Through its independent oversight activities, that is provided throughout the entire standard setting process, the PIOB tries to improve the quality and the public interest focus in the standard-setting process of IAASB. These oversight activities help PIOB to ensure that the development of the standards is in response to stakeholder needs and that they are accountable and transparent. According to PIOB, it fills a necessary function since it is essential for the financial markets that investors can be sure that the available financial information is credible and reliable. PIOB further states that by “overseeing the establishment and adherence to high-quality professional standards, the PIOB seeks to further the international adoption and implementation of such standards and improve the comparability of financial statements across the globe.” (PIOB, n.d.2)

### **5.1.3 IAASB**

*“The IAASB’s objective is to serve the public interest by setting high-quality international standards for auditing, quality control, review, other assurance, and related services, and by facilitating the convergence of international and national standards. In doing so, the IAASB enhances the quality and uniformity of practice throughout the world and strengthens public confidence in the global auditing and assurance profession.”*(IFAC, 2014n, p. 1)

To be able to work with its mission to issue and develop high-quality auditing and assurance standards in the public interest it was decided that IAASB should work as a responsible body under its own authority and within its stated terms of reference (IFAC, 2014o). The standard setting process is shared with the PIOB and the Consultative Advisory Group (CAG), which provides input and guidance. In the work towards its objective IAASB develops and issues different standards there the standard that is in focus through this thesis are the International Standards on Auditing, ISAs. At the end of 2013 there were over 90 jurisdictions that used or were in the process of adopting or incorporating the ISAs, into their national auditing standard or used them as a basis for preparing their national auditing standards.

Even though there might be some differences between the adopting and converging process to ISAs between the different jurisdictions, IAASB has noticed a strong driving force of global adoption and implementation efforts all over the world (IFAC, 2014n). In 2000, the Financial Stability Forum recognized ISA’s as one of twelve sets of standards in the world that represented sound financial practice and whose implementation would improve and support financial stability. The Financial Stability Forum (later FSB) was established as a response by the G7 to the financial crisis in Mexico and Asia in the 1990’s after which large audit firms were criticized for keeping to deficient national auditing standards. The World Bank plays an important part in assessing the compliance with these standards through a program for helping countries for instance to implement ISAs in order to improve the system of financial reporting. This recognition of the ISAs as best practice and the display of public support meant enhancing

their status and making them even more interesting for the EC and also for IOSCO, who now encourages the use of ISAs for both cross-border audits and audits of other listed companies (Humphrey & Loft, 2009; Loft, Humphrey and Turley, 2006; IOSCO, 2009). In 2006, the EC stated that they might agree on making the ISAs mandatory within the EU, however only if the ISAs are internationally generally accepted and if they are formed through a due process with transparency and public oversight (EC, 2006).

There is a rigorous due process that is followed by IAASB in their work towards developing the different standards according to themselves. To be able to serve the public interest they need to consider the views from those who are affected by the standards and they collect and obtain information from a broad spectrum of stakeholders. This spectrum of stakeholders that IAASB identifies consist of: IAASB's CAG, IFAC member bodies and their members, regulatory and oversight bodies, national auditing standards setters, governmental agencies, investors, preparers and the general public (IFAC, 2014p). To be able to consider all these different stakeholders the due process follows several major steps: research and consultation; transparent debate; exposure for public comment; consideration of comments received on exposure; and affirmative approval. A project task group is set up with the responsibility to develop a draft standard by doing a research and consultation. The proposed standard is then presented as an agenda paper open for discussion and debate at an IAASB meeting (IFAC, 2014n). All IAASB meetings are open for the public and all meeting material is publicly available on its home page. The task force's meeting material on the other hand is not publicly available.

Through the consultation process IAASB has help from the IAASB Consultative Advisory Group which is an integral and important part within this process. The objective of CAG is to provide input and assist the IAASB during the consultation with the CAG member organizations and their representatives (IFAC, 2014s). The CAG represent different stakeholders that are interested in the development and maintenance of the objective of IAASB and consist of representatives of regulators, business and international organizations, and users and preparers of financial statements (IFAC, 2014n). Examples of CAG members are the EC, FEE, IASB, IOSCO and BCBS. CAG fills the function, through active consultation with IAASB, to give important public interest input to IAASB regarding its agenda and project timetable, priorities, technical projects and other relevant advice to the activities of IAASB (IFAC, 2014s). A full list of members in CAG is shown in Appendix 5. CAG representatives hold a non-voting observer role at the IAASB's meetings and provide comments and input on the issues discussed regarding the change of the audit report (IFAC, 2014t). The members of CAG therefore have important opportunities to influence the course taken by IAASB on various issues during the change of the audit report.

The organizational structure of IAASB consists of a full-time chairman and 17 volunteer members from around the world. According to themselves is it a balanced board between



practitioners in public practice, with significant experience of auditing and other assurance service, and individuals without this practice. Ten members are nominated by IFAC member bodies and five members are nominated by the Transnational Auditors Committee (TAC), a committee of IFAC that represents the Forum of Firms, i.e. a number of audit firms (Humphrey & Loft, 2009). There is also a requirement that the public should nominate at least three members of the board. With recommendations from the IFAC Nominating Committee the IFAC Board appoints the members. These appointed members also need to be approved by the PIOB (IAASB Fact Sheet, 2013). Besides these members in the board of IAASB there is a small group of observers in the organization, including a representative of CAG, the EC and the Japanese Financial Services Agency (IFAC, 2014p). These observers have a speaking right at the meetings but are not allowed to vote (IFAC, 2014n).

## **5.2 Key Players in International Audit Regulation**

Having outlined the main governance structure surrounding IAASB and IFAC, we move on to further exploring the involvement of international organizations and regulators in auditing and audit reporting, such as the EC, IOSCO, IFIAR, and the FSB. These are actors that for example Humphrey and Loft (2012, p. 334) identify as “key players in the audit regulatory arena”. This arena is explained as having “a myriad of bodies involved in regulatory activities”, and the setting of ISAs is an example of such an activity. Together with the World Bank, BCBS and IAIS, which also will be introduced in this chapter, these organizations are part of IFAC’s Monitoring Group. Humphrey and Loft also took notice of that current audit regulation, connected also to national practice, seems to be “driven by events and strategic action at the global level” (2012, p. 333) and that IFAC, international regulators, such as the EC and IOSCO, and the large multinational audit firms have very interlocking relationships with each other (Humphrey, Loft & Woods, 2009). This section will also show that at the same time as IAASB is undertaking a project to change the standard audit report, the EC, the UK and the US PCAOB have similar agendas.

Before further presentation of the identified key players in international audit regulation an overview of most of these bodies is presented in Table 2 below. The table intends to give an overview of the organizations’ objective or mission as well as the organizations connection or interest of ISAs and the audit report change. Some of the organizations are in the following sections discussed separately while others are discussed briefly in connection to some of the other key players.

Abbreviations	Name	Established	Members	Objective / mission	Connection to ISA/ the change of the audit report
<b>IOSCO</b>	International Organization of Securities Commissions	1983	Association of national securities regulators. 120 such members and 80 other organizations connected to securities markets.	To maintain fair and efficient markets “through the promotion of high quality accounting, auditing and professional standards”.	IOSCO formally endorsed ISAs and encourages them for e.g. audits of cross-border listings. Interested in auditing due to their primary objective to protect investors and make sure they have appropriate information in order to make well-informed investment decisions.
<b>IFIAR</b>	International Forum of Independent Audit Regulators	2006	Association of national audit regulators from 50 countries.	To improve audit quality.	The committee of IFIAR has regulatory meetings with the six largest audit firms where they discuss issues of the audit report. In the due process by IAASB to change the audit report, regular meetings with IFIAR has occurred. Only submitted comment letter to ED.
<b>World Bank</b>	World Bank	1944	Association of 188 nations	To end extreme poverty within a generation and boost shared prosperity.	Assesses developing countries' audit rules and implementation compared to ISAs in order to help them develop their financial reporting infrastructure. Submitted comment letters to ITC and ED.
<b>FSB</b>	Financial Stability Board	2009 (1999)	Authorities from jurisdictions that are responsible for maintaining financial stability, such as regulatory, supervisory and central bank bodies, and also international financial institutions, international standard setters	FSB works at an international level to coordinate the work of national financial authorities and IAASB, among other international standard setting bodies. By doing this they aim to develop and promote the implementation of valuable policies of supervisory, regulatory and financial sector.	FSB considers ISAs as crucial for financial reporting and continuously review the work of IAASB. FSB did not submit any comment letters but has had meetings with IAASB about the audit report.
<b>BCBS</b>	Basel Committee on Banking Supervision	1974	Central banks and organizations which have a direct banking supervisory authority	Improve the understanding of the main supervisory issues and work for improving the quality of the banking supervision over the world.	Submitted comment letters to CP, ITC, ED.
<b>IAIS</b>	International Association of Insurance Supervisors	1994	Association of insurance regulators and supervisors from around 190 jurisdictions that represent around 140 countries.	To promote effective and internationally consistent regulation and supervision of the insurance industry.	Submitted comment letters to CP, ITC, ED.
<b>EC</b>	European Commission	1957	28 member states in the EU.	Represents the interests of EU where it proposes new legislation to the European Parliament and the Council of the European Union.	The EC has since many years considered using the ISAs as mandatory standards within the EU. Did not submit any comment letters.

Table 2: Key Players in The International Audit Regulation

Source: IAASB, 2011; IAASB, 2012; IAASB, 2013; IOSCO Technical, 2009; IOSCO, 2009; IFIAR, 2014; FSB, n.d.1; FSB, n.d.2; World Bank, 2014a; World Bank 2014b; BIS, 2013; FSB, 2012; EC, 2014a, EU, n.d.1; EU, n.d.2

### ***5.2.1 The European Union***

One of the main actors in the context of audit regulation is the European Union (EU) through the European Commission (EC). Through its mandate, the EC can and has imposed rules on auditing on accounting on all of its 28 member states. In the European Union the current rules on auditing are stated by the Statutory Audit Directive (EC, 2006, EC, 2014b). In the aftermath of the recent financial crisis, while questioning how e.g. banks had been given unqualified audit opinions though suffering big losses, the EC issued a Green Paper wanting to stimulate a debate on the role and scope of the audit. The EC also stated that it wanted to take a leading role for international discussions on this subject (EC, 2010).

In April 2014, the European Parliament accepted a preliminary agreement on a revision of the Statutory Audit Directive and a new statutory audit regulation with specific requirements for audits of public interest entities (PIEs). These have been expressed as “some of the world's toughest new rules for accountants” and one main element of the new rules concerns the audit report (Lynch, 2014). The aim is to enhance the audit report’s informative value for investors through expanding the audit report for audits of PIEs. PIEs are listed companies, insurance undertakings or credit institutions, as well as other entities that a member state put into this category because for example the size of the company or the public relevance. The audit report must for such entities include a section of key areas of risk of material misstatement and an explanation of to which extent the auditor was able to detect fraud or other irregularities (EC, 2014b). The EC was one of the two members (the other being FSB) of the Monitoring Group not submitting comment letters as response to IAASB’s consultation processes regarding the change of the audit report.

Parallel to the audit report discussions at the EU level, the United Kingdom (UK) and its Financial Reporting Council (FRC) has been active in discussing it as well, which after consultations has resulted in a revised audit standard on audit reporting for companies applying the UK Corporate Governance Code. Some of the new requirements include the auditor explaining how it applied the assessed risks and the concept of materiality in the planning of the audit and providing a description of the risk of identified material misstatement that affected the design of the audit (PwC, 2013).

As mentioned before, the EC has since many years considered using the ISAs as mandatory standards within the EU. After all, the compliance with IFRS was made mandatory for listed companies’ consolidated statements in 2005, making the adoption of ISAs undoubtedly relevant. A stated reason for hesitating has been that auditors have set the standards without a proper governance structure serving the public interest (Humphrey & Loft, 2012). Humphrey and Loft (2012) though argue that the perception of ISAs seem to have improved since the IFAC reforms, the founding of PIOB, the IAASB’s clarity project and EU’s involvement in IFAC and the standard-setting processes of IAASB. The involvement includes EC being a member of the IFAC Monitoring Group and having representatives as members of PIOB as well. Since 2006, the EC

attends IAASB meetings as an observer and the CAG meetings as a member, and the EC indeed concluded that the governance of IAASB has transformed in such a way that it would be acceptable for the EU to adopt the standards (Directorate General for Internal Market and Services, 2009). A public consultation was undertaken in 2009, showing that an “overwhelming majority” of respondents supported the adoption of ISAs in the EU (Directorate General for Internal Market and Services, 2010, p. 2). An adoption of ISA 700 was not foreseen to bring much change to audit reports (as they looked then), however some consistency among member states would be achieved. The ISAs are to a large extent already in use by the EU member states and applied by the big audit firm networks (EC, 2010).

The importance of EU to IAASB can be seen in different meeting minutes of IAASB. At a December 2011 meeting where IAASB discussed the responses from its consultation paper they also took into account and considered the EC’s Green Paper from 2010 and its responses as well. Another indication about how IAASB consider the EC important is from its meeting in March 2012 where an analysis of EC’s new proposed rules to audit reports was made and compared to the corresponding ISA requirements. (IFAC, 2014u; IFAC, 2014v).

### ***5.2.2 International Organization of Securities Commissions***

Among the members of IOSCO is the American Securities and Exchange Commission (SEC), which will be further discussed in section 5.2.3 below, said to be the most powerful regulator and has also had a vital function within IOSCO (Humphrey & Loft, 2012). IOSCO has been active in audit regulation and audit reporting discussions. In 2007, a roundtable with various stakeholders on audit quality was held, and subsequently in 2009, a consultation report inviting comments was issued raising some of the concerns that came up during the roundtable. The consultation report had the objective of determining if and how the standard audit report or other audit communications should change in order to meet the information needs of investors, and it introduced the information gap (IOSCO Technical Committee, 2009). It also discussed the disadvantages and deficiencies with the current report, such as not providing information that enables investors to distinguish between companies, due to the standardized and pass or fail nature. The opinions and views of the respondents were found to vary significantly, but IOSCO identified extensive support for a global cooperation and strategy to change the audit report, as well as encouragement to consider the research and work by international organizations on the subject (IOSCO Technical Committee, 2010). IOSCO submitted comment letters to all of the sought consultations by the IAASB regarding the audit report.

### ***5.2.3 The United States***

To understand the issues regarding the audit report that are being raised and discussed on a global level, it is relevant to consider the activities in other usually influential jurisdictions. We have previously taken a glance at the European Union and the United Kingdom, and will in this section highlight the audit report situation in the US.

In the US, the audit standards are set and audits of public companies are overseen by PCAOB, which was created from the Sarbanes-Oxley Act of 2002, following the Enron scandal and the breakdown of audit firm Arthur Andersen. Prior to the establishment of PCAOB, the auditing profession was self-regulated without this kind of external oversight. Similar regulatory institutions were created around the world to monitor and control audits, in response to the jeopardized legitimacy of accounting following the large bankruptcies in this time (Malsch & Gendron, 2011). PCAOB is however considered to have wider power and field of responsibility than other corresponding national oversight bodies, since it for example sets standards and have the authority to inspect also work of foreign auditors of companies listed in the US. (Humphrey & Loft, 2012; PCAOB, 2014a) The PCAOB in turn is under oversight from the Securities and Exchange Commission (SEC), who both appoints the members of the board and approves the standards (PCAOB, 2014b). SEC has promoted the importance of international consistency within auditing, but has not yet endorsed the ISAs. Humphrey and Loft (2012) predict that with the increasing acceptance of ISAs around the world, SEC and PCAOB can also be expected to follow that path.

In 2010, a project concerning audit reporting was added to the agenda of PCAOB after a report by the US Department of the Treasury Advisory Committee on the Auditing Profession (ACAP), recommended PCAOB to consider enhancing the audit reporting model through a standard-setting initiative (ACAP, 2008; IFAC, 2014u). After holding outreach activities in 2010 and 2011 that sought views from different stakeholders, PCAOB issued a concept release asking for public comments on how the audit report could be improved (PCAOB, 2011). This was done only a few weeks after the IAASB issued its consultation paper on the same topic. The earlier outreach had shown that investors value the audit but mean that the auditor should provide more useful information based on its important insight to the company. In August 2013, a few months after IAASB issued an Exposure Draft (IAASB, 2013), PCAOB released a corresponding document with proposed new rules (PCAOB, 2014). The new proposal included for example requirements for the auditor to report on critical audit matters. The critical audit matters are addressed as the most important change and explained as matters that during the audit consisted of difficult auditor judgments (PCAOB, 2014). Providing such information is anticipated to reduce the information asymmetry between the corporate management and investors and thereby lead to more efficient capital allocation and less cost of capital. The PCAOB and the IAASB have had ongoing dialogue throughout their processes of changing the audit report standards and have also attended each other's meetings.

#### ***5.2.4 International Forum of Independent Audit Regulators***

PCAOB alongside other national audit regulators from 50 countries is a member of the International Forum of Independent Audit Regulators (IFIAR), a part of IFAC's Monitoring Group (IFIAR, n.d.). Since the start in 2006, IFIAR has grown significantly and increased its

discussions and communications with other international organizations in working towards improving audit quality. Several of these organizations, such as BCBS, the World Bank, the EC and the IOB, are observers during IFIAR's meetings, which is an example of how the relations of regulatory bodies are interlocked (Humphrey & Loft, 2012). The Global Public Policy Committee Working Group of IFIAR regularly meet with representatives from the six largest audit firms' international networks. The purpose is to have a dialogue on issues regarding the audit quality and to obtain a better understanding of each other's work (IFIAR, 2014). Very recently, IFIAR published the results from a member survey, which suggested that audits by the six largest firms on public companies and financial institutions often are partly deficient and that there is a reason for continuing concern regarding audit quality (IFIAR, 2014). IFIAR only responded to the IAASB ED regarding the audit report, but regular meetings between IFIAR and IAASB has occurred during the process of changing the audit report. Through IFIAR meetings, cooperation between regulators is encouraged and information and experiences are shared (ACAP, 2008).

### ***5.2.5 Multinational audit firms***

The large multinational audit firms are very active together within issues concerning accounting and auditing regulation at the international level. When mentioning these firms, we generally refer to the "Big Four" consisting of the networks of EY, KPMG, Deloitte and PwC, and the next two largest being BDO and Grant Thornton. The Big Four are said to "possess significant resources to organize in the face of adversity" which make them powerful in the global political audit arena where the regional or national power has decreased. (Malsch & Gendron, 2011, p.473)

In the beginning of 1999, the then largest five audit firms founded the Global Steering Committee (GSC), since there was a need for a body to represent the common interest of the profession and firms on an international level. This could be seen as a reaction to the criticism the auditors received from the World Bank after the Asian Crisis a few years earlier. The aim of the GSC was also to contribute to making IFAC a stronger standard setter and body for the profession's self-regulation (Humphrey & Loft, 2009). The GSC was in 2004 made into the Global Public Policy Committee (GPPC) with one of the current priorities being the issue of confidence in the audit report (ACCA, 2014). Together with regulators such as IOSCO, IASB, FSB and BCBS it has also published policy papers on various issues connected to accounting and auditing (Humphrey & Loft, 2012).

Audit firms that conduct transnational audits, including the six largest and 21 others, are also gathered in the Forum of Firms (Forum), which is working with globally promoting the use of high-quality standards and audit practices, including the use of ISAs. The Forum of Firms has an "executive arm" called Transnational Auditors Committee (TAC), which is a committee of IFAC and thus formally represents the Forum in IFAC. The Forum and TAC raise issues they believe

is in need of change to IAASB or other standard setting boards, provide expertise and as mentioned before, nominates members to the IAASB (IFAC, 2014r).

The involvement of the large audit firms in IFAC has increased from the start and in 2005, 12 out of IAASB’s 18 members were from or had a background in one of the Big Four firms (Humphrey & Loft, 2009; Loft, Humphrey & Turley, 2005). In 2014, there are at least seven board members that state such a connection (IFAC, 2014n). Another aspect worth noting is that while IFAC used to be financed with only fees from its member bodies, i.e. the national professional associations, approximately a third of its budget now comes from the big audit firms via TAC and the Forum of Firms (Humphrey & Loft, 2012; IFAC, 2013, p. 96) All of the Big Four have submitted comment letters to IAASB’s CP, ITC and ED regarding the audit report. Even though the firms are separate national firms within an international network, they have only submitted one response each. According to observations by Humphrey and Loft (2012) the firms are more and more looking like multinational companies where the global leadership exercises control over regional branches.

### 5.3 Organizational Relationships

As a way of illustrating the interlocking relationships of the organizations and bodies discussed in this chapter, Table 3 below presents a view of membership and observers of the various bodies. It especially displays the involvement among IFAC’s Monitoring Group and CAG with each other.

Monitoring group	CAG	BCBS	FSB	The World Bank	IAIS		IFIAR		IOSCO
Members:	Members:	Observers:	Members:	Observers (2013):	Members:	Observers:	Members:	Observers:	Associate members:
BCBS	BCBS		BCBS					BCBS	
EC	EC	EC	EC	EC	EC			EC	EC
FSB				FSB				FSB	
IAIS	IAIS		IAIS					IAIS	
IFIAR									
IOSCO	IOSCO		IOSCO					IOSCO	
World Bank	World Bank		World		World			World PIOB	
	BusinessEurope EFAA FEE ICGN IIA OECD		OECD SEC	OECD		Deloitte EY KPMG PwC	PCAOB UK FRC		ESMA

Table 3: Organizational Relationships

### 5.4 Chapter summary

This chapter has outlined the context and governance structure around the IAASB and IFAC. It has explained how IFAC and IAASB through support from international regulators such as FSB, IOSCO and the World Bank, have positioned themselves as important players in the international

auditing regulatory space. Further, a number of influential groupings of audit firms and international regulators and their interests in auditing and audit reporting have been outlined. It is shown how heavily interlocked the relationships between those organizations are. It is also worth noting that the simultaneous regulatory activities of for instance the EC, the UK and the US seem to influence also IAASB's approach to develop the audit report rules.



## **6. The Development of Key Audit Matters**

*This chapter presents the findings from the comment letter analysis, which provides an understanding of the views held by different stakeholders in the light of IAASB's proposals. What started as a request for input on the necessity of change ended up with an (at the time of writing) exposure draft of a proposed new standard audit report and a new ISA, called "Communicating Key Audit Matters in the Independent Auditor's Report" (ISA 701). The first section will provide a brief background to the Consultation Paper (CP), while the following sections provides a discussion of the development of the new addition to the audit report that in the Exposure Draft (ED) is called Key Audit Matters<sup>2</sup>. At last the views of the respondents are presented and discussed in comparison to IAASB's final proposals, first regarding the overall support for the concept and then regarding more detailed issues.*

---

### **6.1 Background to the Consultation Paper**

The CP "Enhancing the Value of Auditor Reporting: Exploring Options for Change" (IAASB, 2011), was released in May 2011 by IAASB and was open for comments until September the same year. The main purpose behind this CP was for IAASB to explore the topic of auditor reporting from the views of different stakeholders and from an international perspective. Already before the CP was released, consultations, studies and discussions were undertaken about the audit report's value to users of financial statements. The standard audit report has been a subject for change and improvement several times before this CP came up to the agenda, for example clarifications enhancement, but these earlier changes were intended to decrease the expectations gap and bring more consistency in auditor reporting. Instead of focusing solely on the expectations gap, the consultations, discussions and studies, such as the one made by IOSCO's Technical Committee (2009) showed a new gap, namely the information gap. IAASB wanted to consult with different users globally to understand both the different views about the content of the audit reports and to understand the different information needs. To their CP, feedback was sought from a broad range of stakeholders to the audit report, e.g. users of audited financial statements, preparers, auditors and regulators. By this feedback IAASB said it hoped to get a better understanding of the opinions on the different areas discussed in the CP to help them in the consideration process about how to improve the audit report (IAASB, 2011).

### **6.2 The Consultation Paper, 2011**

The CP (IAASB, 2011) explored different options for change in auditor reporting to narrow the information gap and expectation gap as shown in Figure 4 below.

---

<sup>2</sup> The term "Key Audit Matters" is used in the ED (IAASB, 2013) as the name for the new section of the audit report containing additional information from the auditor. The term "Audit Commentary" refers to this same section, but was used in the CP (IAASB, 2011) and ITC (IAASB, 2012).

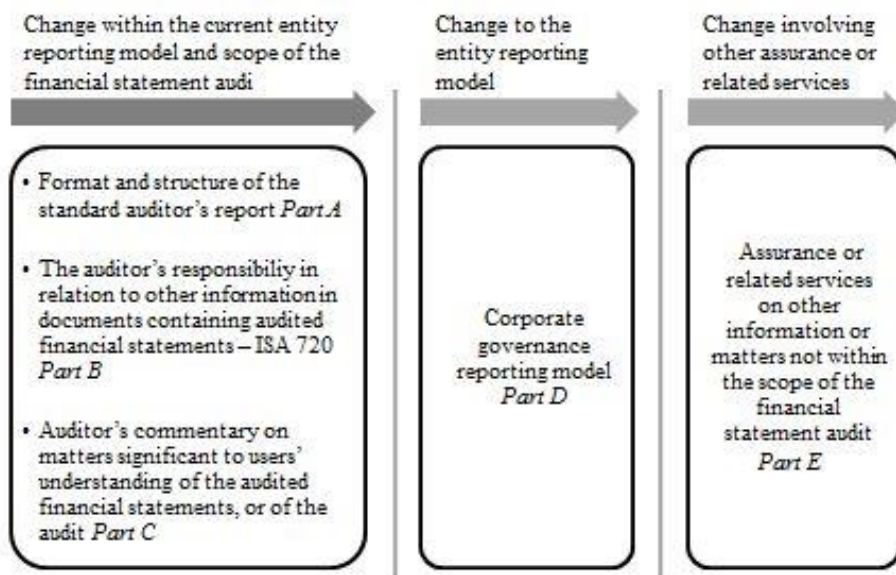

Figure 4: Options for Change  
Source: (IAASB, 2011, p. 12)

Since this thesis focuses on the auditor commentary, the further presented information will be within the area of Part C showed to the left in the model. This is also one of the options that the IAASB chose to proceed with. It is mentioned in the CP that some users of the audited financial statements believe that the information that the auditor obtains through the audit process about the entity would be of great value for them in their decision-making and some users have also suggested an expanded commentary on topics such as e.g.:

- Key business, operational and audit risks that are considered by the auditor during the performance of the financial audit;
- Different methods and judgments used in the valuations processes;
- Significant unusual transactions and when changes of accounting policies have a considerable impact;
- Evaluation of the efficiency and quality of risk management and the governance structure

It is also mentioned in the CP that users that want an expanded audit report believe it will be beneficial because it would lead to better transparency of the entity, its audited financial statements and the audit itself (IAASB, 2011). An auditor commentary is not a new phenomena and the current position for the auditor to draw the users' attention to certain matters is regulated in ISA 706 "Emphasis of Matter Paragraphs and Other Matter Paragraph in the Independent Auditor's Report", as explained in section 4.2.

According to IAASB some research has shown that the use of the different paragraphs in ISA 706 often is misunderstood and readers relate it as being something negative and similar to a qualification of the audit opinion (IAASB, 2011). In the CP it is mentioned that both an

increased use of the Emphasis of Matter paragraph as well as providing additional information about the audit by additional paragraphs has been suggested. The discussions relating to additional information both involve pros and cons depending on which user's view is taken into account and through the CP the IAASB address the different perspectives. IAASB also asks for opinions on whether the auditor should provide insights about the entity and about the quality of its financial reporting. Examples of these could be insights and perceptions about the quality and effectiveness of the entity's management, risk management and its governance structure (Consultation Paper, 2011). Regarding an auditor commentary, the IAASB (2012), among other things, asks respondents for their views and reactions to:

- The auditor presenting additional information about the audit in the audit report
- The auditor presenting insights about the entity or the quality of its financial reporting in the audit report

### **6.3 The Invitation to Comment, 2012**

Moving forward in time to the next draft, the "Invitation to Comment: Improving the Auditor's Report" (IAASB, 2012), discussions about an Auditor Commentary continued. Compared to the CP that was asking more general questions, the questions asked in the ITC were more detail specific with follow up questions depending on if the respondent supported the related issue or not. Mentioned in the ITC were suggestions of the points that should at a minimum be considered by the auditor when it comes to the decision whether an audit commentary should be provided in the audit report or not (IAASB, 2012, p.23f):

- "Areas of significant management judgment (e.g., in relation to the entity's accounting practices, including accounting policies, accounting estimates, and financial statement disclosures).
- Significant or unusual transactions (e.g., significant related party transactions or restatements).
- Matters of audit significance, including areas of significant auditor judgment in conducting the audit, for example:
  - Difficult or contentious matters noted during the auditor other audit matters that would typically be discussed with an engagement quality control reviewer or TCWG; and
  - Other issues of significance related to the audit scope or strategy."

In the ITC the IAASB discussed whether the new concept of Auditor Commentary as a more holistic concept would lead to that the Emphasis of Matter and Other Matters paragraphs no longer would be necessary. One of their proposals was that these matters could be replaced by and included in the new Auditor Commentary. Among other areas discussed and directly questioned in the ITC compared to the CP was about the stated objective of the Auditor

Commentary and to which entities’ audits this Audit Commentary should be provided (ITC, 2012).

The stated objective for the Audit Commentary as suggested in the ITC was to “provide transparency about matters that are, in the auditor’s judgment, likely to be most important to users’ understanding of the audited financial statements or the audit” (IAASB, 2012, p. 25). In the illustrative audit report provided in the ITC are five examples shown of how the Audit Commentary could be used in practice. The examples were provided to show that the matters and related content that the auditor should comment on could vary depending on the context and the judgment of the auditor. These illustrative examples are new for the ITC. The Auditor Commentary has developed from the CP to the ITC as shown in Table 4 below.

Consultation Paper	Invitation to Comment
”Matters significant to users’ understanding of the audited financial statements, or of the audit”.	“Without modifying our opinion, we highlight the following matters that are, in our judgment, likely to be most important to users’ understanding of the audited of the financial statements or our audit.”
	“Our audit procedures relating to these matters were designed in the context of our audit of the financial statements as a whole, and not to express and opinion on individual accounts or disclosures.”

Table 4: The Auditor Commentary Definition  
 Source: (IAASB, 2011, p.28; IAASB, 2012, p.10)

#### 6.4 The Exposure Draft, 2012

In the Exposure Draft “Reporting on Audited Financial Statements: Proposed New and Revised International Standards on Auditing (ISAs)” (IAASB, 2013) the concept of Auditor Commentary as it was suggested in the ITC, is changed. The name of the earlier Auditor Commentary is now changed to Key Audit Matters and instead of requiring such disclosure for audits of PIEs, the suggestion now changed to listed entities. In addition, a new standard for determining what information the auditor should disclose was developed. The proposed use of ISA 701 “Communicating Key Audit Matters in the Independent Auditor’s Report” will according to IAASB lead to a major change in practice (IAASB, 2013).

Presented in Table 5 below is how the information about Audit Commentary or later Key Audit Matters would be presented in an audit report. The left column shows the proposal from the ITC and the right column the proposal from the ED. In both the ITC and ED, IAASB provided examples of what key audit matters could be. One example used in both ITC and ED is goodwill,

which regarded the level of uncertainty and judgment involved in the impairment test. The information in the ED was changed to being more focused on the audit procedures related to each matter, but a paragraph containing only information about audit strategy was removed. The examples from ED are provided in an illustrative audit report in Appendix 6. The IAASB’s aim is that the information provided in this section of the audit report would be shaped after the circumstances of the specific audit and company. The additional information should also be consistent with what is disclosed in the financial statements.

Invitation to Comment	Exposure Draft
Audit Commentary	Key Audit Matters
<p>“Without modifying our opinion, we highlight the following matters that are, in our judgment, likely to be most important to users’ understanding of the audited of the financial statements or our audit.</p>	<p>“Key audit matters are those matters that, in our professional judgment, were of most significance in our audit of the consolidated financial statements. Key audit matters are selected from the matters communicated with [those charged with governance], but are not intended to represent all matters that were discussed with them”</p>
<p>Our audit procedures relating to these matters were designed in the context of our audit of the financial statements as a whole, and not to express and opinion on individual accounts or disclosures.”</p>	<p>“Our audit procedures relating to these matters were designed in the context of our audit of the consolidated financial statements as a whole. Our opinion on the consolidated financial statements is not modified with respect to any of the key audit matters described below, and we do not express an opinion on these individual matters.”</p>

Table 5: The Key Audit Matters Definition  
Source: (IAASB, 2012, p.10; IAASB, 2013, p.13)

The main changes from ITC to ED are:

- That the auditors should provide matters that in their professional judgment are of most significance in their **audit** of the consolidated financial statements, and not what kind of information that would be most likely important to the **users’ understanding** of audited of the financial statements
- That the provided additional information in the ED should be selected from matters that have been discussed with those charged with governance (TCWG);
- That the proposed ISA is required for listed companies in the ED instead of PIEs in the CP.

The first main change mentioned above is related to how to decide which matters that should be included. It was proposed in the ED to have a principles-based approach that will leave it to the auditor’s judgment to decide at what level of detail that individual matter should be included in the auditor’s report. Further, the IAASB mentions that for the communication of key audit matters to have value to users it will also be necessary for the auditor to explain why some

matters are of significance in the audit. It is thus needed for auditors to provide insight about why a matter is seen as a key audit matter. The proposed ISA 701 however allows for flexibility for the auditor to determine this. It is also among the suggestions that the judgment of the auditor should determine if it is necessary to include an explanation to why a matter is seen as a Key Audit Matter. To assist the auditor, paragraphs in ISA 701 include guidance to support the professional judgment regarding how this should be communicated (IAASB, 2013, p. 21).

Mentioned already in connection with the CP was ISA 706 “Emphasis of Matter Paragraphs and Other Matter Paragraphs” and discussions regarding this standard continued in the ITC. In the ITC focus was on whether these paragraphs should be kept separately or be replaced by the Auditor Commentary, later Key Audit Matters. In the proposals of the ED it is suggested that ISA 706 should remain and that it would be no change to the current concepts of Emphasis of matter Paragraphs and Other Matters paragraphs. Instead IAASB mention that the relationship between the proposed ISA 701 and the current ISA 706 need to be clarified to make it clear that matters determined to be a Key Audit Matter is not referred to the paragraphs of ISA 706.

## **6.5 Comment letters**

After having reviewed IAASB’s process of developing an Auditor Commentary section and its different proposals, the views and roles of the respondents will be discussed. A first basic conclusion we were looking to make when analyzing comment letters was if the respondent was generally positive or negative to the concept of Auditor Commentary as introduced by IAASB. In Table 6 below the overall opinions regarding the suggested new element of Auditor Commentary is illustrated. The conclusions about the different respondents’ views about this new element in the audit report are based on their responses in their comment letters to the CP and the ITC, or just one of them in the case of just one submitted letter. Table 6 intends to give an overview about the general opinions to be able to distinguish the actors that are clearly not positive to this new proposal from the ones that are more supportive. The table does not intend to give a description regarding the arguments behind the position to the proposed change and instead this will be further described in subsequent sections. All examined comment letters are taken from IFAC’s website (IFAC, 2014b; 2014c)

The fourth column in Table 6 shows for which entities the different respondents think Auditor Commentary should be required, if stated so in the comment letters. In some of the respondents comment letters was it not possible to code out what they thought about the issue and in these cases they are described with not applicable (n.a.) instead. Since most of the respondents had concerns they are coded in the table as “Supports the concept, raises concerns” when they are positive to the concept of Auditor Commentary but have several concerns. Other respondents that were more positive to the concept are coded as “Supports the concept”. Some of the respondents explicitly stated in their responses that they strongly disagree with the the concept and are coded thereafter while the others that didn’t explicitly mention it with such words are

mentioned as “Doesn’t support the concept”. As seen in the table some respondents were supportive to IAASB’s work with exploring the concept but also mentioned that they were satisfied with the current audit report.

Given that the table intends to provide an overview, not all stakeholders groups will be separately discussed regarding their overall support for the commentary, but rather mentioned in the discussion of different issues. However, four stakeholder groups will be discussed also separately, namely preparers, investors and analysts, the Big Four audit firms and the regulators and oversight bodies, for the reasons stated in section 2.4.4 of the method chapter. An overview is provided in Appendix 2 over the organizations’ full names and to which of IAASB’s calls for comment they responded.

Respondent group		1. Overall opinion of Auditor Commentary	2. Requirement for which entities?
<b>Preparers of Financial Statements</b>	Group of 100 A	Strongly disagrees with the concept	n.a.
	CNRL	Strongly disagrees with the concept	All entities
	BusinessEurope	Strongly disagrees with the concept	Left to jurisdiction to decide
	100 Group UK	Doesn't support the concept	n.a.
<b>Profession</b>	<b>KPMG</b>	Partial support	Listed entities
	<b>EY</b>	Increasing support, raises concerns	Listed entities
	<b>PwC</b>	Supports the concept, raises concerns	Listed entities
	<b>Deloitte</b>	Supports the concept, raises concerns	For certain entities (e.g. PIEs)
	Mazars (France)	Supports the concept	All entities
	SAR	Supports the concept	PIEs
	Baker Tilly	Strongly disagrees with the concept	For PIEs, when consistent definition
<b>Regulators and oversight bodies</b>	EAIG	Supports the concept, raises concerns	n.a.
	<b>BCBS</b>	Supports the concept, raises concerns	PIEs
	<b>World Bank</b>	Doesn't support the concept	n.a.
	<b>IOSCO</b>	Doesn't support the concept	n.a.
	<b>IAIS</b>	Supports the concept, raises concerns	All entities
	ESMA*	Supports the concept, raises concerns	Listed entities and PIEs
<b>TCWG</b>	OECD	Supports the concept, raises concerns	Certain entities
	IIA	Some support, raises concerns	All entities
	AICD	Doesn't support the concept	PIEs (lif listed)
<b>Investors and analysts</b>	BlackRock	Supports the concept	PIEs
	HEOS	Supports the concept	Listed entities
	EUMEDION	Supports the concept	Listed entities
	S&P	Supports the concept	All entities
	ICGN	Supports the concept	PIEs, including listed Companies
<b>Member Bodies and Other Professional Organizations</b>	ICAN	Supports the concept, raises concerns	Listed entities and for significant PIEs
	ZICA	Some support, satisfied with the current report	n.a.
	ACCA*	Supports the concept	All entities
	ICAEW*	Supportive, but satisfied with the current report	Listed entities
	ICPAS	Supports the concept, raises concerns	PIEs
	CAQ*	Supports the concept, raises concerns	n.a.
	EFAA	Supportive, but satisfied with the current report	PIEs
	FEE*	Supportive but not for SMEs	PIEs
	IDW *	Some support, satisfied with the current AR	Listed entities
<b>National Auditing Standard Setters &amp; Public Sector</b>	UK FRC*	Supports the concept, raises concerns	Certain entities
	ASB	Supports the concept	Listed entities
	CAASB	Doesn't support the concept	Left to jurisdiction to decide
	JICPA	Undecided	Listed entities
	NAOS	Supports the concept	Provide AC for public sector entities
	CNAO	Supports the concept	n.a.
	AGNZ	Doesn't support the concept	Most likely for PIEs

Table 6: The Overall Opinion Regarding Auditor Commentary  
Source: (IFAC, 2014b; 2014c)



### **6.5.1 Overall support for Auditor Commentary**

In the CP the concept of Auditor Commentary was not specifically defined, which lead to many respondents having concerns about the approach. Concerns raised by almost every respondent involved blurring the division of responsibilities, being that the responsibility of management or those charged with governance (TCWG) is to provide information while the responsibility of auditors is to provide assurance on such information. As explained in section 6.3, the concept of Auditor Commentary was further developed in the ITC. A concept in the audit report where the auditor is expected to give some information about the entity and the audit on the financial statements or repeat information already contained in the financial statements would according to many make the expectation gap even wider.

### **6.5.2. For which entities Auditor Commentary should be required**

One issue that the IAASB has sought feedback on is whether the Auditor Commentary, subsequently Key Audit Matters, should be required for all or just certain entities. The final suggestion in ED was that it would be required for listed companies. The specific question regarding this was asked in the ITC. The suggestion then by IAASB was that it would be required for Public Interest Entities (PIEs). As shown in Table 6 there were a variety of responses to this issue. In some responses it was not possible to code out for which entities the respondent thinks it should be required and some of the respondents that didn't like the concept of Auditor Commentary have not answered the question. The most common views were that the requirement would be for either all entities, listed entities, PIEs or left to each jurisdiction to decide.

Among the investors only Standard & Poor's thought it should be required for all entities with the argument that they seek the same level of information from all entities regardless of size and nature. Even though CNRL didn't support the concept they also thought that there should be one standard audit report applicable to all entities. BlackRock specifically mentioned that they wanted investment companies to be excluded from the requirement. The preparers, who did not support the concept, did not answer for which entities they thought Auditor Commentary should be mandated. There were different opinions among the audit firms. Three of the big four audit firms, KPMG, EY and PwC, expressed concerns regarding international differences in the definition of PIEs, and therefore recommended mandating Auditor Commentary to audits of only listed entities, while proposing IAASB to further consider the definition of PIEs. Baker Tilly was also of the view that the definition needed to be clearer and mentioned that if a consistent definition of PIEs was developed it could be accepted for PIEs but not for non-PIEs. Mazars was the only audit firm in the sample that thought it should be required for all entities.

Looking at Deloitte's comment letter to the CP compared to the one to the ITC they appeared to have changed their mind. In the earlier response they stated that all changes made to the audit report should apply to all kinds of entities, by stressing the importance of uniformity. Otherwise

they said the inconsistency will make the information gap and expectation gaps even wider. In the ITC response however, Deloitte agrees with IAASB that the Auditor Commentary only should be required for audits of PIEs only. PwC on the other hand, promoted already in their CP response that they supported additional information requirements for audits of listed companies and PIEs, which is similar to how IAASB's approach in the ED.

In the comment letters from regulators and oversight bodies, such as IOSCO, EAIG and the World Bank it was not clear for which entities they thought Auditor Commentary should be required. Among the other respondents in this group the opinions were that it should be required for either PIEs, listed or all entities. BCBS also mentioned in connection to their opinion of PIEs that they think that the definition of PIEs should include banking organizations. IAIS explained that they thought Auditor Commentary should be required for all entities because otherwise there is a risk that the audit reports without an Auditor Commentary could be perceived as having lower quality.

The responses from TCWG, member bodies and other professional organizations and national auditing standard setters and public sector showed a variety of opinions. Both concerns about the definition of PIEs and the big burden it would be for SMEs were mentioned. According to EFAA it should only be required for PIEs since the existing paragraphs of Emphasis of Matter and Other Matters are enough to satisfy the user's information needs of the financial statements of SMEs.

The IAASB motivated its decision to only mandate Key Audit Matters for listed entities by saying that it listened to responses that had concerns about a proper definition of PIEs. Further, it said that a possible requirement for other entities can be evaluated after the new rules have been implemented. IAASB also noted that national auditing standards or law could require the new rules for other than listed entities. The reason that it is not required for all entities is that the requests for this type of commentary comes from institutional investors and analysts, and that users of other companies than listed and PIEs probably have access to this kind of information anyway through for example direct contact with management (IAASB, 2013).

### **6.5.3. Preparers of Financial Statements**

Preparers were one particular group that strongly disagreed with IAASB's approach. Examples of arguments used were:

- Blurs distinction of role and responsibility of auditor and management or TCWG.
- Could become costly to implement by auditors
- Could create tension between auditors and TCWG / management
- The content of the commentary could be interpreted as a hidden qualification of the audit opinion

The preparers promoted other approaches for IAASB to take instead. Two of these were:

- 100 Group UK recommended keeping a short-form audit report with Emphasis of Matter and Other Matters paragraphs, while explaining the auditor's approach more, including e.g. applied materiality levels and locations the auditor visited. Views on key issues and judgments should instead be reported by the company's audit committee.
- BusinessEurope suggested removing the Auditor Commentary concept altogether and instead focusing on making the section on auditor responsibilities more narrative and clear, which would include disclosures of areas that were identified as significant audit risks according to requirements in other ISAs.

It is not found that the suggestions of these two preparers were incorporated into IAASB's proposals in either ITC or ED. The proposed audit report is now four pages long, instead of the current one page audit report. In the illustrative audit report provided in the ED (see Appendix 6) Key Audit Matters takes up one and a half pages. The suggested disclosure of audit procedures and significant audit risks could however possibly be included by the auditor within the description of Key Audit Matters although they are not among the requirements or guidelines by IAASB.

#### **6.5.4 Investors and Analysts**

While having many of the same concerns as preparers, the group of investors was generally supportive of the concept of Auditor Commentary. The concerns were rather mentioned as aspects and principles to consider while further developing the criteria to the new section of additional information. The investors list information which they believe the Auditor Commentary should contain in order to be useful, much of which can be seen as later related to IAASB's concept of Key Audit Matters. Such information is for example identification of significant or unusual transactions, areas with significant management judgment and matters of audit significance or audit judgment. The investors, alone or in agreement, however also considered other information to be very relevant and requested information that by IAASB was not directly included in Key Audit Matters:

- Identification of significant new accounting principles and evaluation whether they are preferable
- Auditor assertion on whether the financial accounts are prepared on a neutral basis
- Information contained in the audit completion memo, such as unadjusted audit differences, difficult issues or "close calls" and their resolution
- Internal control weaknesses

#### **6.5.5 The Big Four Audit Firms**

The Big Four, i.e. KPMG, PwC, Deloitte and EY, are part of what in chapter 5 in this thesis calls the context around IAASB. Many of IAASB's board members have, as mentioned before, a

background from one of these firms. In their responses to the CP, all four were rather concerned about providing additional information in the audit report. In the responses to the ITC however, the answers was a bit more optimistic and they all acknowledged that an Audit Commentary would be valuable, especially when drawing attention to specific disclosures in the financial statements. However, as explained in the coming paragraph, not all their proposals or concerns were incorporated into the proposed concept of Key Audit Matters.

KPMG were in the response to the CP in favor of changing the corporate governance model instead of the audit reporting model (see Figure 4), and regarding the audit report, they, together with EY, favored an expanded use of the Emphasis of Matter paragraph. As for IAASB's examples of additional information that could be provided by the auditor, KPMG, EY and Deloitte believed the disadvantages, such as efforts and costs for timely creating such a commentary, would outweigh the benefits. In the ITC response, KPMG, EY and Deloitte were supportive of the auditor providing information that is likely to be important for users' understanding of financial statements, but not the audit. Similarly, PwC stated support for the Auditor Commentary to consist of highlighting of matters from the financial statements where significant management judgment was made, if useful for users' understanding.

All firms stressed the importance of finding out what information users would consider most useful in their decision making. One of the reasons for excluding information about the audit itself was the anticipation that the auditor would not be able to explain complex issues regarding the audit procedures in a short and understandable way, causing the user to misunderstand for example the level of assurance given. Further, PwC stated in its CP response that reporting on information, such as areas of difficulty during the audit and audit procedures regarding matters of significant risk, would for example be damaging for audit quality since the risk of hurting the auditor's relationship with management and TCWG. Deloitte recommended IAASB that the following matters should be basis for consideration when determining issues to disclose in an audit commentary:

- Transactions that are significant or uncommon
- Matters with significant management judgment

Such matters can be included in the Key Audit Matters as proposed by the IAASB in the ED, but it is not the basis for consideration as shown in section 6.4. It is rather the audit, the areas of difficulties within the audit and the significant risks that are basis for consideration when determining which matters to disclose according to proposed ISA 701.

### **6.5.6 Regulators and Oversight Bodies**

The sample of respondents from regulators and oversight bodies consist of both the important organizations surrounding IFAC described in chapter 5, i.e. IAIS, World Bank, IOSCO, BCBS, and in addition the European bodies of ESMA and EAIG. The opinions differed among the

regulators and oversight bodies regarding the proposed concept of Auditor Commentary. All of them raised concerns such as the audit report becoming boilerplate and that the auditor should not provide information that is not already in the financial statements. However, there are some differences where EAIG, BCBS, IAIS and ESMA are more supportive to the proposed change while IOSCO and World Bank is not that supportive.

BCBS was generally positive to the proposals and also recommends in their answer to the CP that the IAASB should consider to include in the Auditor Commentary an assurance on the internal controls and its effectiveness, which is however not included in the proposal in ED. EAIG welcomes the proposed change and believes that it is a very appropriate way to inform the users of the financial statements about the audit but also criticizes it for being too descriptive in nature and not giving the added value of the auditor's views based on how the audit was conducted. They also recommend that IAASB should consider adding to the Auditor Commentary a summary of the auditor's risk analysis and audit strategy used to reduce significant audit risks where the risk of fraud should be included. Even if such a summary is not included in the Key Audit Matter in the ED, the reference to risk of material misstatement due to fraud is included.

Both the World Bank and IOSCO have been categorized as not supportive of the concept because of concerns and that they questioned the value of the Auditor Commentary. For example, World Bank and IOSCO explain that they do not see how the Auditor Commentary and its lower threshold differ from Emphasis of Matter and they also point out that it would require too much competence from the users to understand the suggested information in Auditor Commentary.

## **6.6 Views on Specific Issues**

Except for respondents overall opinion of IAASB's proposal of Auditor Commentary, some specific issues related to Auditor Commentary/Key Audit Matters has been identified. These are selected with the aim of illustrating if the different respondents' opinions are in line with the suggestions in ED or not. As will be evident in the tables, not every respondent has provided a specific opinion on every issue. This since some of the issues were not explicitly asked for by IAASB and since the extent and focus of the individual responses vary to a great extent.

### ***6.6.1 Whether or Not to Include Materiality***

Among the respondents, there were many different views regarding what information the auditor should provide in the new section of Auditor Commentary. Given the guidelines proposed by the IAASB in the ED, it is not always easy to determine which suggestions got incorporated. However, one kind of information related to the planning of the audit, namely materiality, was by some respondents particularly pointed out as either very useful or very inappropriate to disclose.

Three investors were of the view that applied materiality also should be disclosed, while one specifically wanted to exclude materiality thresholds and audit procedures from the Auditor Commentary section. Two regulators and oversight bodies meant that providing information about applied materiality would be useful for users' understanding of the depth of the audit and therefore the assurance the auditor can give. KPMG, Mazars and Deloitte however doubted the usefulness of and interests in such information. They highlighted the risk of such information being confusing, due to the inconsistency between audits, and due to either being too short or too long to understand. BlackRock also did not support disclosure of materiality due to the many quantitative and qualitative considerations that lie behind the determination of a materiality threshold. IAASB states in the ED that it does not believe that issues regarding the planning and scope of the audit, such as materiality, would meet the definition of a Key Audit Matter and further states that such a disclosure will not be required.

Whether information about applied materiality should be included in Auditor Commentary		
	Yes	No
<b>Preparers</b>	Group of 100 A, 100 Group UK	CNRL
<b>Profession</b>	Baker Tilly	Mazars, Deloitte, KPMG
<b>Regulators and oversight bodies</b>	EAIG, ESMA	
<b>TCWG</b>		
<b>Investors and analysts</b>	HEOS, EUMEDION, ICGN	BlackRock
<b>Member Bodies and Other Professional Organizations</b>		
<b>NSS and Public Sector organizations</b>	UK FRC	

Table 7: Materiality Included in The Auditor Commentary

### ***6.6.2 Whether the Use of Key Audit Matters Should be Voluntary for Other Audits***

As mentioned earlier, the IAASB in its ITC proposed that a section of Auditor Commentary would be mandatory for audits of PIEs. Furthermore, the proposal entailed that it would be up to the discretion of the auditor whether to include it for audits of other entities. Table 8 below shows some of the views. PwC and especially Baker Tilly presented strong views against it. They were of the opinion that the quality of audit reports to non-PIEs in which no Auditor Commentary was provided would be perceived as of lower quality. Baker Tilly expressed that if leaving the inclusion voluntary, it would lead to big inconsistencies among firms and the IAASB would therefore undermine the quality of the audit report to small entities. Standard & Poor's pointed out that they want the same kind of information available for each company, regardless of size and if public or private. Therefore they proposed that Auditor Commentary should be compulsory for audits of all entities.

Table 8 is based on the respondents that have explicitly mentioned whether they believe it should be voluntary or not to use an auditor commentary. In some cases where the respondents strongly disagree with the concept of Auditor Commentary, they do not mention for which this should be required or if it should be voluntary. In many of the comment letters a third option is favored where it is up to national legislation to decide for which entities it should be required, other than for the ones IAASB mandates. Some respondents, i.e. BusinessEurope, ICAEW, CAASB, IDW and JICPA, thought it should be up the national legislation to decide regarding the entities that IAASB does not require Audit Commentary for.

Auditor Commentary voluntary for other audits		
	Yes	No
<b>Preparers</b>		
<b>Profession</b>	Deloitte, EY, Mazars, SRA	Baker Tilly, PwC
<b>Regulators and oversight bodies</b>		
<b>TCWG</b>	AICD	
<b>Investors and analysts</b>	HEOS	S&P
<b>Member Bodies and Other Professional Organizations</b>	ICPAS, ACCA, EFAA, FEE	
<b>NSS and Public Sector organizations</b>	ICAN, UK FRC	

Table 8: Auditor Commentary Voluntary

### 6.6.3 How to Select Key Audit Matters

When determining which issues to include as a Key Audit Matter, the IAASB proposes in its ED that the auditor should choose from matters that are communicated with TCWG. ISA 260 “Communication with Those Charged With Governance” already requires such communication with TCWG, who are responsible for overseeing the financial reporting process. This two-way communication is stated important for establishing a good beneficial relationship that, among other things, enables the auditor to understand the entity better and together with TCWG reduce the risk of material misstatement in the financial statements. The idea of the auditor providing users with insights to this communication has developed through the IAASB’s consultation process. In the CP, IAASB mostly provided readers with different possible options on what additional information previous feedback had suggested and their advantages and disadvantages. In the ITC, IAASB’s proposal was that Audit Commentary would highlight matters that are “in the auditor’s judgment, likely to be most important to users’ understanding of the audited financial statements or the audit” (ITC, 2012, p. 22). Examples of such information were provided, but further guidance for the auditor was not yet developed. As was discussed above, this description led to many concerns from respondents, since it includes both matters on the

audit and the actual financial statements, and that it is not considered the role of the auditor to know what users need in order to understand the financial statements.

In the selection of this study, the respondents displayed to the left in Table 9 below had already in their response to the CP stated that insight to the auditor's communication with TCWG would be very useful. At the same time, the respondents displayed to the right explicitly stated that this kind of communication is problematic and inappropriate for the auditor to disclose. Mazars meant that there would be value for shareholders and other users to obtain information on important issues that arise during the audit, such as key audit matters that are discussed among the auditor and the board or audit committee. CAASB, although not positive to the Auditor Commentary as a whole, mentioned that if IAASB proceeds with such a section in the audit report, there should be a connection between that and the matters discussed with TCWG. Baker Tilly and KPMG (in its response to CP) on the other hand, while acknowledging the attractiveness of such information for users, warned for the consequences of disclosing this information in the audit report that is meant to be as a two-way communication. There is a risk that the less informed reader gets confused by these statements and finds the financial statements less credible as a result. In its response to ITC, KPMG however mentioned that the communication with TCWG could be considered when determining if a matter was seen as important for the users' understanding of financial statements. Baker Tilly, while still withholding its concerns, also suggests that the specific issue of significant risks that auditors communicate with TCWG could be linked to the Auditor Commentary. CAQ has another argument, being that requiring public disclosure of such information would lead to weaker discussions between the auditor and TCWG because of worry that the information discussed will need to be disclosed in the audit report. The two investors in Table 9 both requests insight into such communication, but believe this rather should be disclosed by TCWG or the Audit Committee than by the auditor.

Disclosing information about matters communicated with TCWG		
	Positive	Negative
<b>Preparers</b>		
<b>Profession</b>	KPMG, EY, Mazars	Baker Tilly
<b>Regulators and oversight bodies</b>		
<b>TCWG</b>		
<b>Investors and analysts</b>	HEOS, EUMEDION	
<b>Member Bodies and Other Professional Organizations</b>	ACCA, IDW	CAQ
<b>NSS and Public Sector organizations</b>	CAASB	

Table 9: Matters Communicated with Those Charge With Governance



#### 6.6.4 Key Audit Matters in Relation to Emphasis of Matter and Other Matters

In the current ISA requirements, the auditor can highlight matters in an Emphasis of Matter paragraph that the auditor consider essential for the users’ understanding of the financial statements. In an Other Matter paragraph, topics that are relevant for the understanding of the audit can be highlighted. In the ITC, IAASB proposed that the new section of Auditor Commentary in the audit report, which was considered to be a more “holistic” approach, would replace the possible use of these two paragraphs (IAASB, 2012, p. 23). Table 10 below shows that some investors, a member body and a regulator agreed with the IAASB, while audit firms, regulators like IOSCO and some more member firms disagreed and thought these concepts should be kept even though an Auditor Commentary is introduced. The arguments for keeping the Emphasis of Matter and Other Matter were for example by UK FRC and ICAEW that the power of such paragraphs would be gone when mixed with the other matters and that it is useful to have a gradation of the auditor comments. For entities where an Auditor Commentary would be required, JICPA thought it appropriate to replace the Emphasis of Matter and Other Matter paragraphs, but considered it necessary to keep them for the audits of other entities, where the commentary is not required.

In the ED, the IAASB had changed its view and was proposing to keep the Emphasis of Matter and Other Matter paragraphs, with the argument that it highlights matters that are not defined as a key audit matter, but also because audits of other entities than where a section of Key Audit Matters is required may need this device.

Emphasis of Matter and Other Matter paragraphs should be kept even though Auditor Commentary is introduced		
	Yes	No
<b>Preparers</b>		
<b>Profession</b>	PwC, Mazars, SRA	
<b>Regulators and oversight bodies</b>	IOSCO, IRBA, ESMA	IAIS
<b>TCWG</b>		
<b>Investors and analysts</b>		EUMEDION, ICGN
<b>Member Bodies and Other Professional Organizations</b>	ACCA, EFAA, FEE, ICAEW	JICPA
<b>NSS and Public Sector organizations</b>	UK FRC	

Table 10: Emphasis of Matter and Other Matter Paragraphs

#### 6.7 Chapter Summary

This chapter has focused on the process of developing the new section of the standard audit report called Key Audit Matters. The results from the comment letter analysis from responses to

the IAASB's outreach documents CP and ITC have been presented. In the light of different issues it can be seen that different actors have been more or less active in trying to influence the standard setting. The "success" of their argumentation and opinions varies to a great extent depending on the issue.

## 7. Analysis

*In this chapter, we return to the concept of the regulatory space. The empirical material presented in chapter 4-6 will provide a basis for analyzing the audit report standard setting as a regulatory space, in which different actors are active in trying to influence. First it is discussed how the shape of the regulatory space in which IFAC and IAASB operates changes, due to the influence of major actors such as international regulators. Subsequently the relationships between the regulators, the big audit firms and IFAC will be analyzed. The issue of how the audit report change emerged on the IAASB's agenda is also discussed. Lastly, these parts are integrated with the results from the comment letter analysis from the perspective of who influenced the regulatory space.*

---

### 7.1. The Construction of Regulatory Space

The purpose of this thesis was to provide an understanding of the political process of changing the audit report and the context in which this change takes place. To understand the regulatory space where IFAC and IAASB have decided to make this change of the audit report it is important to look beyond their borders and examine other actors as well as question who is inside the space and involved in the regulatory process. The first research question addressed this by questioning who the major actors are that influence IAASB and how they are participating in this particular regulatory space. Therefore, the aim of this section is to discuss the audit regulatory space where focus is set on the international level with IFAC and its auditing standards board IAASB in the center of standard setting. It is within this space that issues are constructed as problems and appropriate responses are undertaken as part of the process.

For a long time, the global (as well as national) auditing profession, through IFAC, was self-regulated. However as the concept of regulatory space proposes, historical timing and crises play a great role in shaping the space. In 2001-2002, the Enron and WorldCom financial reporting scandals were revealed, followed by Parmalat in Italy in 2003, which were seen as audit failures causing criticism of the auditing profession's self-regulation. A loss of confidence of financial information and the credibility of the auditor opinion in audit reports triggered the forming of the Monitoring Group over IFAC. The Monitoring Group and IFAC decided upon reforms to improve IFAC's due process standard setting and the work in the public interest, to restore the trust in the auditing profession and audit reports. EC also put pressure or motivation for these due process reforms, when it stated that the mandating of ISAs in the EU could be considered if the standards go through a due process in the public interest. This can by the concept of regulatory space be explained as a crisis that interrupted the usual routine of self-regulation and triggered a demand for a different institutional planning. Hence the regulatory space was reconstructed through the entering of new major participants, like the regulators and organizations in the Monitoring Group and the establishment of a, from auditors, independent

oversight body PIOB. As the space changed, the power allocation changed, where the members of the Monitoring Group gained more insight and influence over the standard setting process at the expense of the auditing profession. That being said, as will be discussed further on, the auditing profession is not powerless, but rather works in cooperation with others in the public interest. The regulatory space of standard setting can be seen as mainly divided between the audit profession through IFAC, international regulators and the big audit firms.

## **7.2 Organizational Relationships**

When aiming to understand regulatory space and how regulation is accomplished, the relationships between organizations are important to consider. This can also point to who is inside and who outside the regulatory space. When outlining the main organizations surrounding IFAC, it became evident how all of these are involved in each other's agendas. Through the regulatory space metaphor this can be explained by the premise that in order for regulation to be accomplished, cooperation between organizations is almost inevitable.

Starting with the Monitoring Group, now consisting of BCBS, EC, IAIS, IFIAR, IOSCO and the World Bank, it is found that they have many connections to each other apart from forming this group. In Table 3 in section 5.3, the connections of mutual membership and observation are compiled, which shows the complexity and intertwining of the organizations. For example it can be seen that the EC, the World Bank and IOSCO are very involved with its fellow members of the IFAC Monitoring Group. Conclusions on the effects of these relationships regarding the audit report are difficult to draw without more insight to the meetings and conversations. Through being part of the Monitoring Group, these actors had much influence over IFAC during the IFAC reforms, which except from the creation of PIOB resulted in e.g. less IAASB members appointed by the audit firms in Forum of Firms and a more rigorous due process in standard-setting. The Monitoring Group also has a continuous dialogue with the leadership of IFAC through the IFAC Regulatory Liaison Group where IFAC's activities and issues regarding audit regulation are discussed with also the auditing profession. Through this channel shared meanings can be developed regarding appropriate actions to take. However, we argue that the Monitoring Group bodies that also are members of IAASB's Consultative Advisory Group (CAG), are likely to have more direct influence on the IAASB and its standard setting through this channel, as representatives of CAG attends all IAASB meetings and uses its opportunity to come with much input, not least on the development of the new audit report. The members of the Monitoring Group and a selection of members from CAG can also be seen in Table 3 in chapter 5. The selection consists of the organizations that were also included in the commentary analysis presented in the previous chapter. Apart from the opportunity to submit comment letters, these actors can therefore present their views to IAASB also through CAG and influence that way.

Within the auditing regulatory space there are actors that should not be ignored, namely the multinational audit firms. Since these firms are both part of the standard setting as well as being

the regulated parties of this space, their interest in the audit report could be seen both from the perspective of their working practice, work load and relationship with clients, and as a struggle to maintain perceived legitimacy of their profession by responding to demands from stakeholders. The legitimacy of the auditor profession has in the past been a common topic where the auditors have been criticized in the aftermath of scandals and crises. Historically it also been shown that the large multinational firms have been involved and responded to these issues in the regulatory space of auditing. The communication and relations to international regulators started taking place due to this, leading to the interlocking relationships of today. One example to a response by the auditors to global critique is how the largest five audit firms in 1999 founded the GSC, later the GPPC, to have a body that represents their interest of the profession and firms on an international level. The current priority issue of the body is the confidence in the audit report and since it also has a mission to contribute to make IFAC a stronger standard setter its involvement and interest in the audit report change is noticed. In addition to this body, the audit firms are more directly involved with IFAC through the Forum of Firms and its Transnational Auditors Committee in IFAC. Through these channels the big audit firms nominate members to the IAASB and are involved in the audit report regulation by providing expertise and recommendations to IAASB. That they also contribute to about a third of IFAC's budget illustrates their interest, involvement and also their resources. Together they can be regarded a powerful and resourceful actor in the regulatory space. Despite this involvement in IAASB and IFAC the big audit firms are nonetheless active in responding to IAASB's consultation processes, which they do as separate networks. Even with their common organizations and forums, the opinions and views among the firms are sometimes but not always aligned in the submitted comment letters. These deviating views are however detailed issues and they all agreed on that the auditor commentary as a concept would be valuable for users.

### **7.3 The Audit Report becomes a “problem”**

During the last two decades, the international auditing standards of IAASB grew in significance. The FSB and World Bank had already marked them as important for financial stability, the EU had implied a possible adoption, and after the clarification of the ISAs, IOSCO also openly promoted their implementation. In the end of the 2000 however, the global finance crises spread, which sparked new criticism and demands. The crisis gave rise to requests for more transparency in financial reporting, and the clarified ISAs were issued in time for being implemented after this. However, there were also requests for auditors to provide more information, to share the unique insights they have in their clients' businesses. The increasingly complex world of financial reporting and international business, hence were circumstances to which the audit report must keep up and adjust. As the history of the audit report over the last century has shown, many earlier changes attempted to address an expectation gap while the focus now had changed to an information gap. The demand and expectation of the audit report of the participants in the regulatory space had increased, due to changes in the financial reporting context in which the audit report has an important function. The audit report of IAASB's predecessor and the audit

report in the US were very similar, and an explanation to that can be the dominance of the big audit firms in both of these standard setters. The concern was therefore directed to both these audit reports.

The US Department of Treasury (ACAP, 2008) recommended PCAOB to initiate an audit report project, while acknowledging the perceived shortcomings of the standard audit report and stating a belief that improving it would provide investors with more relevant information. IOSCO (IOSCO Technical Committee, 2009) published a report on exploring improvements to auditor communications discussing the perceived disadvantages with the current audit report and displaying IOSCO's interest in the issue. Additionally, the EC (2010) in its Green paper wanted to take a leading position in a debate on the role of auditors due to questioning of how auditors could give unqualified audit reports to banks soon before they failed. These actors had collected input from various stakeholders and can from the lens of regulatory space be seen as participants in the space initiating a regulatory conversation about the usefulness of the audit report. Similar to how Young (1994) found that participants in the regulatory space around FASB constructed accounting issues as problems, the IOSCO, EC and the US Department of Treasury participated in constructing the issue of audit reporting as a problem. The IAASB responded in order to develop an appropriate solution to meet the expectations of the other participants in the space. After all, a priority mission of IFAC is the worldwide use of ISAs, and to achieve this it is necessary to respond international organizations, such as IOSCO and the EC. These can be seen as important for this mission since they have power over their members and can recommend or mandate the use of ISAs. From a regulatory space perspective they can be seen as having the "right resources" for dominating the space. By ordering studies on the topic and subsequently issuing a consultation paper, the IAASB subsequently took improving the auditor report as a project on its agenda.

#### **7.4 Stakeholder Influence on the Proposed New Audit Report**

The second research question in this thesis asks if it is possible to see whether some actors are more successful than others in influencing the rules to the new audit report. By successfully influencing it is meant that the respondents' comments are incorporated into IAASB's proposals. In the coming sections the results from the comment letter study is analyzed. Looking at this from the theoretical lens of regulatory space, the responses of comment letters can be viewed as attempts of trying to occupy and influence the space. By submitting comments, actors struggle for their opinions and their benefits and compete for space. The power of those participants may determine how successful they are in their struggle. Major actors were previously identified and discussed regarding their roles in the regulatory space. They both had past roles in shaping the current the regulatory space as well as initiating a regulatory conversation regarding the audit report. It can be anticipated that these actors have more influence on the proposed rules than others, or that their views are already aligned and established within IAASB. However, it will be further argued that such a distinction is not easy to make.

As part of serving the public interest and fulfilling the expectations the major and minor participants in the regulatory space have, the IAASB encourages stakeholders to, comment on proposals. As discussed in the Methodology chapter, comment letters are considered a powerful way to lobby. IAASB's Consultation Paper (CP) and Invitation to Comment (ITC) had similar approaches where the proposals to enhance the audit report and to serve the public interest were discussed with both already identified concerns and suggested benefits. In many cases therefore the comment letters' content reflected and confirmed these thoughts. In the CP different suggestions to improve the audit report were mentioned and many responses to the CP confirmed the need to explore how the audit report could be improved in order to narrow the perceived expectation gap and information gap. Due to this "confirmation", the suggested approach could be interpreted as an appropriate solution to the constructed problem by the participants in the regulatory space even if some respondents were not of the view that an expanded auditor commentary was the right solution.

#### **7.4.1 The Actors' Overall Influence on the New Audit Report Section**

As the empirical data in chapter 6 showed, there were various opinions on IAASB's proposal of an Auditor Commentary, subsequently called Key Audit Matters, in the audit report. In some of the stakeholders groups more similar opinions could be found while in others the opinions differed. Some of the respondents strongly disagreed with or did not support the Auditor Commentary concept, which requires the auditor to disclose additional information of the audit and the audited financial statements. These were from the thesis sample the group of preparers, Baker Tilly, the World Bank, IOSCO, AICD, AGNZ and CAASB. Except from the preparers it is difficult to draw conclusions about the disagreement of the concept in connection to a categorized stakeholder group. Worth noting is that neither the World Bank or IOSCO, which are found to be very integrated within IFAC and IAASB, through e.g. CAG and Monitoring Group, agrees with the approach taken. These major actors were found to question the value of the proposed Auditor Commentary and be concerned that it would be too complex for users' to comprehend.

From a broad and general perspective of the regulatory space metaphor, the actors that did not support the concept could be seen as "excluded" from the space when it comes to the issue of Key Audit Matters. This since IAASB decided, against their struggles, to move on with the concept and develop a new standard and section for it in the proposed audit report. However, it is not that easy and appropriate to think of them as excluded without further consideration, only because they did not support the concept in the examined comment letters. For example, they can have influenced the process in other ways, between the public consultations. To explicitly say that the actors not supporting the Auditor Commentary as presented in the CP and ITC therefore are excluded from regulatory space, is not appropriate. In the case of the specific respondents mentioned, i.e. preparers, IOSCO World Bank and Baker Tilly, it could be said that as far as the ED goes, their overall opinions did not get through. It is also not considered likely that the direction taken by IAASB will change substantially when finalizing the new standard.

In contrast to the preparers and the other disagreeing actors, generally supportive opinions among the investors were found. The investors and analysts, as users of the audit report, can from the lens of regulatory space be seen as actors that directly benefit from this regulation. Also national standard setters, such as ASB, NAOS and CNAO, the member body ACCA and the smaller audit networks of Mazars and SRA were very positive. By looking at Table 6 a tempting conclusion to make could be that investors and those other actors were “listened to” by IAASB and successful in their attempts to influence the audit report, since the IAASB decided to proceed with the approach that these actors approved on. The level of detail and ambiguity that comes with the Auditor Commentary and the corresponding Key Audit Matters, suggest however that such conclusion cannot be made. It can be said these actors were successful in terms of that their views were in line with the proposals of IAASB.

It can be noted that the rationale for change came from the purpose of providing users, especially investors and analysts, with better information and therefore what these actors consider useful is particularly interesting for the IAASB. The group of investors and analysts however also had some concerns. A difference compared to the preparers, who didn’t approve of the concept of Auditor Commentary at all, was that the concerns were rather used to highlight the areas they found important for IAASB to consider to make the Auditor Commentary useful. Much of these concerns and suggestions can be noticed in the proposed Key Audit Matters but not all of the points that the investors requested are incorporated. By their comment letters and suggestions it could be seen that the actors both wanted to be a part of the regulatory space and tried to influence IAASB with information they believed is important for the auditors to provide.

All of the respondents categorized as the auditing profession more or less supported the provision of an Auditor Commentary, except for Baker Tilly. Holding in mind that these actors are directly affected by the proposal of Auditor Commentary, as they are the regulated ones, it is clear in their comment letters how they try to influence and be a part of this space. Just as investors were seen as beneficiaries of this regulation, it is presumed that it is in the interest of auditors’ to promote satisfying solution for users, for the sake of the perceived usefulness of their auditing profession. As opposed to the investors that promoted disclosure of various information concerning the audit, the Big Four for instance marked that they only thought it appropriate to base the commentary on highlighting matters of the financial statements. The IAASB however changed the objective of Auditor Commentary from focusing partly on users’ understanding of financial statements, to having its basis taken from matters significant in the audit. Still, the proposed rules are principle based and what to disclose about each key audit matter is up to the judgment of the auditor. This principle-based approach allows flexibility for the auditor and could be an effect of the raised concerns from the profession about the difficulties in providing a fair insight into the complex audit procedures and that the costs and efforts should not outweigh the benefits.



#### **7.4.2 The Actors' Influence on Certain Issues**

Two tables are presented below. The first one, Table 11 is a compilation of the four tables from the previous chapter, and the second one, Table 12 represents the issue for which entities the new section of the audit report should be required. Both tables aim to show how some of the participants in the regulatory space were successful or not successful in getting their opinion incorporated into the ED of the new audit report standards. It can be stressed again that this is a selection of issues, based on important features of the new rules but also based on the circumstance that it is possible to determine if they are incorporated in the ED at all. This was not always the case due to the ambiguity of the discussed matters and proposed rules. When actors are situated in the red columns it indicates that their view on the matter was the opposite of the view presented by IAASB in its final draft.

Within this selection of issues connected to the new rules of Key Audit Matters in the audit report, it is shown difficult to conclude if one respondent category is more successful than another. It could also be worth to consider alternative groupings to make sense of the results. One such grouping could include the actors that were found to be closely involved with IAASB and IFAC in its formal structure, i.e. the major actors in the regulatory space. These groups were the big audit firms and international regulators. For example, the Big Four audit firms are relatively often represented in the green columns of the figure, together with Mazars, which points towards that (1) they suggested approaches in their comment letters to CP and ITC, which the IAASB later incorporated into the ED and/or (2) that they agreed with IAASB's approach on issues, with which IAASB continued to proceed or more importantly (3) they are involved within IAASB and therefore IAASB's proposals already take into account many of their opinions. Other so called "insiders" are not as represented in these tables as the audit firms. IOSCO together with other regulators, member bodies and audit firms agreed that Emphasis of Matter should be kept, which also IAASB changed its proposal into. Baker Tilly on the other hand was not as successful in gaining results for its suggestions. In the terms of regulatory space it could be expressed as Baker Tilly is a less powerful actor within the space. However, it could also be that for example Baker Tilly has deviating opinions from the majority of the respondents, and that IAASB want to proceed with the requests of the majority. In three of the four issues in the table, the IAASB's ED was aligned with the views of the majority of respondents from our selection that had commented on the specific issues in question. Regarding the question of requiring disclosures on materiality, it could however be interpreted that CNRL, Mazars, Deloitte, KPMG and BlackRock even as a minority convinced IAASB that such an approach was not appropriate. However without the full selection of respondents, such a conclusion cannot be made. Also regarding the issue of for which entities the Auditor Commentary should be required, the majority of our selection did not convince the IAASB. As the board mentions itself, it listened to the argument of that a definition of PIEs needed to be considered, and subsequently concluded that the new standard should be tested first before mandating it to further entities than listed entities.

Emphasis of Matter and Other Matter paragraphs should be kept even though Auditor Commentary is introduced			Whether information about applied materiality should be included in Auditor Commentary		
	Yes	No		Yes	No
Preparers			Preparers	Group of 100 A, 100 Group UK	CNRL
Profession	PwC, Mazars, SRA		Profession	Baker Tilly	Mazars, Deloitte, KPMG
Regulators and oversight bodies	IOSCO, IRBA, ESMA	IAIS	Regulators and oversight bodies	EAIG, ESMA	
TCWG			TCWG		
Investors and analysts		EUMEDION, ICGN	Investors and analysts	HEOS, EUMEDION, ICGN	BlackRock
Member Bodies and Other Professional Organizations	ACCA, EFAA, FEE, ICAEW	JICPA	Member Bodies and Other Professional Organizations		
NSS and Public Sector organizations	UK FRC		NSS and Public Sector organizations	UK FRC	

Disclosing information about matters communicated with TCWG			Auditor Commentary voluntary for other audits		
	Positive	Negative		Yes	No
Preparers			Preparers		
Profession	KPMG, EY, Mazars	Baker Tilly	Profession	Deloitte, EY, Mazars, SRA	Baker Tilly, PwC
Regulators and oversight bodies			Regulators and oversight bodies		
TCWG			TCWG	AICD	
Investors and analysts	HEOS, EUMEDION		Investors and analysts	HEOS	S&P
Member Bodies and Other Professional Organizations	ACCA, IDW	CAQ	Member Bodies and Other Professional Organizations	ICPAS, ACCA, EFAA, FEE	
NSS and Public Sector organizations	CAASB		NSS and Public Sector organizations	ICAN, UK FRC	

Table 11: Compilation of Identified Issues

For which entities Auditor Commentary should be required			
	Listed entities	All entities	PIEs or Other
Preparers		CNRL	Business Europe
Profession	KPMG, EY, PwC	Mazars	Deloitte, SRA, Baker Tilly
Regulators and oversight bodies		IAIS	BCBS, ESMA
TCWG		IIA	OECD, AICD
Investors and analysts	HEOS, EUMEDION	S&P	BlackRock, ICGN
Member Bodies and Other Professional Organizations	ICAEW, IDW	ACCA	ICAN, ICPAS, EFAA, FEE
NSS and Public Sector organizations	ASB, JICPA		UK FRC, CAASB, AGNZ, NAOS

Table 12: Requirement of Auditor Commentary

As noticed in chapter 6, Deloitte displays an example of how an opinion changed throughout IAASB's consultation process. In its CP response, it was a strong promoter for a uniform and consistent audit report for all entities, while in the ITC, it agreed with IAASB in only mandating Auditor Commentary for certain entities. From the lens of regulatory space, this can be seen as how shared meanings are developed through regulatory conversations and how interests are constructed and reconstructed depending on the situation, which in Deloitte's case was tougher rules which is considered only appropriate to mandate for certain audits.

### **7.5 Chapter Summary**

In this chapter the most relevant points from the empirical data has been analyzed by the application of the regulatory space concept. The main points will be further presented in the next chapter of Conclusions.

## 8. Conclusions

This thesis has considered the context in which the political process of changing IAASB's standard audit report takes place. When considering the circumstances around which the audit report has changed in the past and is changing today, it is argued that IFAC and IAASB are involved with and influenced by a number of global actors. Using the chosen theoretical framework, these actors can be called major or important occupants of the regulatory space. Many of these are part of a grouping consisting of international regulators, such as in particular IOSCO, the World Bank, IFIAR, BCBS, FSB, IAIS and the EC. By forming the Monitoring Group to oversee IFAC, they evaluate and influence its activities to make sure IFAC works in the public interest. In addition, the Monitoring Group appoints members and conduct oversight over PIOB, which in turn oversees the IAASB to improve its standard setting in the public interest. This shows that the members of Monitoring Group are an important part of the governance structure of IFAC and IAASB. Also through a Consultative Advisory Group which attends IAASB's meetings, the members of the Monitoring Group together with other stakeholders have an advisory role to the IAASB. Throughout the thesis it has also been argued that the relationships between the group of international regulators are heavily interlocking and that they have common goals of maintaining financial stability. In this, auditing has an important part.

Audit firms, and especially the Big Four are also through the Forum of Firms and its committee in IFAC, powerful participants in the regulatory space, even if they had a stronger position of self-regulation before the corporate scandals of for instance Enron and the subsequent establishment of PIOB. Having outlined IFAC's past it has been seen that the mentioned organizations took a great part in helping IFAC achieve the strong position it has today in the international financial infrastructure, and the widespread acceptance and use of IAASB's auditing standards.

All of the above mentioned actors are involved in the process of changing the standard audit report. The EC and IOSCO participated in constructing the issue of audit reporting as a problem within the regulatory space which together with request for change arising in the US helped put the audit report on IAASB's agenda. The EC's contemporary proposals for audit report change has also been taken into account by IAASB during theirs. All of the international regulators have also been involved in IAASB's outreach activities, with the purpose of discussing and obtaining input on the audit report issue. In addition to this, IOSCO, the World Bank, BCBS and IAIS and the Big Four audit firms submitted comment letters to IAASB's proposal presented in the Consultation Paper (CP) and Invitation to Comment (ITC).

Throughout IAASB's consultation process, which consisted of mainly three invitations for public stakeholder comments, many actors apart from the international regulators and audit firms mentioned above, took the opportunity to present their views and suggestions and thereby trying

to influence the regulatory space. Especially the proposed new requirements of the auditor providing an additional commentary section, later called Key Audit Matters, was discussed as it represents a particularly substantial change of audit practice. Some respondents from the selection of this thesis such as preparers, IOSCO, the World Bank and Baker Tilly rather disagreed with IAASB's proposal. They considered it the wrong approach to address the information gap, which is said to be the reason behind this new proposed section of the audit report. In the light of that the IAASB continued to pursue this approach, it can be said that these actors were not successful in influencing this new approach in the audit report.

Since the request for the auditor to provide additional information originally came from investors, these stakeholders can be seen as successful in this circumstance. The position of the investors which we examined here were also supportive of IAASB's proposals. Some of them got their views on certain issues incorporated into IAASB's proposed scope and objective of Key Audit Matters. As presented and discussed thoroughly in the previous chapter of analysis, many other actors have been successful or unsuccessful in the sense of suggesting an approach to a matter which is later incorporated or not incorporated into the final draft. The majority of the Big Four audit firms have for example "had it their way" regarding several issues, while also the opposite regarding other issues. From the issues that we focused upon, there are no clear patterns suggesting that some actors are systematically not listened to, or that the views of some are systematically incorporated in the final draft. It was mentioned that for instance preparers and Baker Tilly were not very successful in influencing the proposed rules to the issues that we looked upon. Apart from that, the conclusion arrived at is that we perceive it problematic to determine whether some actor or stakeholder group is more successful than others in influencing the proposed rules. This can be due to a number of reasons (some of which are discussed in chapter 9).

One factor that increases the difficulty to in a valid way compare the opinions of actors is the great variety in the length of comment letters and the number of issues discussed by respondents. This means that the views of all respondents cannot be analyzed in comparison to IAASB's final proposals or in comparison to each other. Another reason is that the opinions or suggestions presented in comment letters are not always clear and distinct to interpret. Many respondents rather raise concerns which they recommend IAASB to take into account. It is difficult to determine if these sometimes ambiguous concerns or principles have influenced the proposed rules. In summary, it can be seen that the majority of respondents has managed to get their view on certain issues incorporated into the scope, objective or requirements to the new audit report standard. It is however not possible to fairly distinguish some of them as more successful than others in influencing the rules. We can hence see that many actors are involved and trying to influence the regulatory space, but it is not clear who the most influential actors are in the consultation process.

## 9. Reflections

By seeing the current change of IAASB's audit report standard as part of a regulatory space, this thesis has outlined the roles of major actors in the construction of regulatory space and regulatory conversations. Through this it has contributed to a way of looking at the current process of changing the audit report as part of a greater context in which the participants of the regulatory space has influence. The conclusions have shown that a standard setting process can involve complex considerations. These include which direction a change should take and the details the change should contain. There is a myriad of different interests and opinions a standard setter needs to consider and not all wishes can be fulfilled.

The concept of regulatory space has been used through this thesis as both a guidance to approach the research purpose as well as a tool for analyzing the empirical data. Some advantages and disadvantages have appeared with the chosen theoretical framework. In chapter 3 it was pointed out how this theory is considered useful for analyzing changes to rules within an existing regulatory arena. The use of the "lens" of regulatory space was a helpful analytical tool for organizing and explaining the findings of the empirical data. Similar to the limitations of making a case study (Ryan, Scapens & Theobald, 2002) we found that with the concept of regulatory space it can be difficult to draw boundaries for what to include in the scope of the research, i.e. to limit the regulatory space. The regulatory space involves studying the context in which regulation occurs and the relationships between participants, but there are no clear boundaries or guidance for how far the researcher should go in outlining the regulatory space. This aspect in turn led to this thesis having some limitations.

This thesis focused on the organizational relationships and participation of a group of global organizations, audit firms and regulators as the main boundaries and scope for deeper examination. In addition, the comment letters of a selection of other major and minor stakeholders to IAASB were examined to try and distinguish their influence on a particular standard changing process. If different boundaries had been set and a wider focused used, it could have led to broader insights into the regulatory space. Therefore it would be interesting for further research to adopt an even wider lens or to deeper examine the organizational relationships.

By doing this, other important participants of the space could possibly be captured and results of more informal influence could be analyzed. Another suggestion for further research is to do a similar study of the audit report change of the IAASB but when the rules are finalized. In such a study it would likely be easier to see patterns of influential actors, both since the issues of discussions are more clear and defined, and since the whole process from the beginning to the end can be examined. A quantitative approach for analyzing comment letters could be taken, in order to systematically code and sort opinions and arguments and compare to the final standards.

## References

### Articles

- Adilođlu, B., & Vuran, B. (2011). A multicriterion decision support methodology for audit opinions : the case of audit reports of distressed firms in Turkey, *International Business and Economics Research Journal*, vol. 10, no. 12, pp. 37-47
- Canning, M. & O'Dwyer, B. (2013), The dynamics of a regulatory space realignment: Strategic responses in a local context, *Accounting, Organizations & Society*, vol. 38, no. 3, pp. 169-194
- Church, B.K., Davis, S.M. & McCracken, S.A. (2008), The Auditor's Reporting Model: A Literature Overview and Research Synthesis. *Accounting Horizons*, vol. 22, no. 1, pp. 69-90
- Coram, P.J., Mock, T.K., Turner, J.L., & Gray, G.L. (2011), The Communicative Value of the Auditor's Report, *Australian Accounting Review*, vol. 21, no. 3, pp. 235-252,
- Gangolly, J., Hussein, M., Seow, G. & Tam, K. (2002), Harmonization of the auditor's report, *International Journal Of Accounting*, vol. 37, no. 3, pp. 329-346
- Gold, A., Gronewold, U. & Pott, C. (2012), The ISA 700 Auditor's Report and the Audit Expectation Gap - Do Explanations Matter?, *International Journal Of Auditing*, vol. 16, no. 3, pp. 286-307
- Golafshani, N. (2003). Understanding Reliability and Validity in Qualitative Research, *The Qualitative Report*, vol. 8, no. 4, pp. 597-607
- Humphrey, C., Loft, A., & Woods, M. (2009), The global audit profession and the international financial architecture: Understanding regulatory relationships at a time of financial crisis, *Accounting, Organizations & Society*, vol. 34, no. 6/7, pp. 810-825
- Jamal, K. & Sunder, S. (2013), To change or not?, *CA Magazine*, vol. 146, no. 5, pp. 37-40
- Jonnergård, K. (2012), Quality Control through Venetian Blinds: Regulating the Swedish Auditing Industry, *European Accounting Review*, vol. 21, no. 1, pp. 51-85
- Jonnergård, K., & Larsson, U. (2007), Developing Codes of Conduct: Regulatory Conversations as Means for Detecting Institutional Change, *Law & Policy*, vol. 29, no. 4, pp. 460-492
- Loft, A., Humphrey, C. & Turley, S. (2006) In pursuit of global regulation, *Accounting, Auditing & Accountability Journal*, vol. 19, no. 3, pp. 428-451
- MacDonald, L.D. & Richardson, A.J. (2004), Identity, appropriateness and the construction of regulatory space: the formation of the Public Accountant's Council of Ontario, *Accounting, Organizations & Society*, vol. 29, no. 5/6, p. 489
- Malsch, B. & Gendron, Y. (2011), Reining in auditors: On the dynamics of power surrounding an "innovation" in the regulatory space, *Accounting, Organizations & Society*, vol. 36, no. 7, pp. 456-476
- Porter, B., Ó hÓgartaigh, C., & Baskerville, R. (2012), Audit Expectation-Performance Gap Revisited: Evidence from New Zealand and the United Kingdom. Part 1: The Gap in New Zealand and the United Kingdom in 2008, *International Journal Of Auditing*, vol. 16, no. 2, pp. 101-129

- Roussey, R.S. (1996) New Focus for the International Standards on Auditing, *Journal of International Accounting & Taxation*, vol. 5, no. 1, pp. 133-146
- Stenka, R. & Taylor, P. (2010), Setting UK standards on the concept of control: An analysis of lobbying behaviour, *Accounting And Business Research*, vol. 40, no. 2, pp. 109-130
- Tutticci, I., Dunstan, K. & Holmes, S. (1994), Respondent Lobbying in the Australian Accounting Standard-setting Process: ED49: A Case Study, *Accounting, Auditing & Accountability Journal*, vol. 7, no. 2, p. 86
- Wallage, P. (1993), Internationalising Audit: A study of audit approaches in the Netherlands, *European Accounting Review*, vol. 2, no. 3, pp. 555-577
- Weirich, T.W. & Reinstein, A. (2014), The PCAOB's Proposed New Audit Report, *CPA Journal*, vol. 84, no. 4, pp. 24-29
- World Trade Organisation supports IASC standards (1997). *Management Accounting: Magazine For Chartered Management Accountants*, vol. 75, issue 2, p. 3
- Yen, A.C., Hirst, E. & Hopkins, P.E. (2007). A Content Analysis of the Comprehensive Income Exposure Draft Comment Letters. *Research in Accounting Regulation*, Vol. 19, pp. 53-79
- Young, J.J. (1994), Outlining Regulatory Space: Agenda Issues and the FASB, *Accounting, Organizations & Society*, vol. 19, no. 1, pp. 83-109

### ***Literature***

- Bryman, A. & Bell, E. (2011). *Business research methods*. 3rd edn, Oxford: Oxford University Press
- Bryman, A. & Bell, E. (2013). *Företagsekonomiska forskningsmetoder*. 2nd edn. Stockholm: Liber
- Carmichael, D.R. & Winters, A.J. (1986) The Evolution of Audit Reporting. in D.R. Carmichael & J.J. Willingham, (eds), *Perspectives in Auditing*, 4th edn, New York: McGraw-Hill International
- Flint, D. (1988). *Philosophy and principles of auditing: an introduction*. Basingstoke: Macmillan Education
- Hancher, L. & Moran, M. (1989) Organizing Regulatory Space. in L. Hancher & M. Moran (eds) *Capitalism, Culture and Regulation*, Oxford: Oxford Univ. Press, pp. 271-297
- Humphrey, C. & Loft, A. (2012). Contemporary Audit Regulation - Going Global! in G. Caprio, (ed) *Handbook of Key Global Financial Markets, Institutions, and Infrastructure*, Academic Press, pp. 333-343
- Humphrey, C. & Loft, A. (2009). Governing Audit Globally: IFAC, the New International Financial Architecture and the Auditing Profession. in C.S. Chapman, D.J. Cooper & P.B. Miller (eds) *Accounting, Organizations, and Institutions*, Oxford: Oxford University Press, pp. 205-232
- Mason, J. (2002). *Qualitative researching*. 2nd edn, London: Sage



Porter, B., Simon, J. & Hatherly, D.J. (2008). Principles of external auditing. 3rd edn, Chichester: Wiley

Ryan, B., Scapens, R.W. & Theobald, M. (2002). Research method and methodology in finance and accounting. 2nd edn, London: Thomson

Smith, M. & Taffler, R.J. (2000) A Chairman's Statement: A content analysis of discretionary narrative disclosures. *Accounting Auditing & Accountability Journal*, vol. 13, no.5, pp. 624-646

Thyer, B. A. (ed) (2001). *The handbook of social work research methods [E-book]*. Thousand Oaks, Calif.: SAGE

### ***Electronic sources:***

Association of Chartered Certified Accountants (ACCA). (2014). Audit Firm Collaboration. Available at: <http://www.accaglobal.com/in/en/research-insights/audit-society/audit-collaboration.html> [Accessed 5 May 2014]

Advisory Committee on the Auditing Profession (ACAP). (2008). Final Report. The Department of the Treasury. Available at: <http://www.treasury.gov/about/organizational-structure/offices/Documents/final-report.pdf> [Accessed 5 May 2014]

Bank for International Settlements (BIS). (2013) Basel Committee on Banking Supervision Charter. Available at <http://www.bis.org/bcbs/charter.pdf> [Accessed 20 May 2014]

Directorate General for Internal Market and Services (2009). Consultation on the Adoption of International Standards on Auditing. European Commission. Available at: [http://ec.europa.eu/internal\\_market/consultations/2009/isa\\_en.htm](http://ec.europa.eu/internal_market/consultations/2009/isa_en.htm) [Accessed 1 May 2014]

European Commission (EC). (1996). Green Paper. The Role, the Position and the Liability of the Statutory Auditor within the European Union. Available at: [http://ec.europa.eu/internal\\_market/consultations/docs/2010/audit/green\\_paper\\_audit\\_en.pdf](http://ec.europa.eu/internal_market/consultations/docs/2010/audit/green_paper_audit_en.pdf) [Accessed 1 May 2014]

European Commission (EC). (2006). DIRECTIVE 2006/43/EC <http://eur-lex.europa.eu/LexUriServ/LexUriServ.do?uri=CONSLEG:2006L0043:20080321:EN:PDF> [Accessed 14 April]

European Commission (EC). (2010). Green Paper. Audit Policy: Lessons from the Crisis. Available at: [http://ec.europa.eu/internal\\_market/consultations/docs/2010/audit/green\\_paper\\_audit\\_en.pdf](http://ec.europa.eu/internal_market/consultations/docs/2010/audit/green_paper_audit_en.pdf) [Accessed 1 May 2014]

European Commission (EC). (2014a). Euromission at work. Available at: [http://ec.europa.eu/atwork/index\\_en.htm](http://ec.europa.eu/atwork/index_en.htm) [Accessed 20 May 2014]

European Commission (EC). (2014b). Reform of the EU Statutory Audit Market - Frequently Asked Questions. Available at: [http://europa.eu/rapid/press-release MEMO-14-256\\_en.htm](http://europa.eu/rapid/press-release_MEMO-14-256_en.htm) [Accessed 1 May 2014]

European Union (EU). (n.d.1). EU member countries. Available at:

[http://europa.eu/about-eu/countries/member-countries/index\\_en.htm](http://europa.eu/about-eu/countries/member-countries/index_en.htm) [Accessed 20 May 2014]

European Union (EU). (n.d.2). A peaceful Europe – the beginnings of cooperation. Available at: [http://europa.eu/about-eu/eu-history/1945-1959/index\\_en.htm](http://europa.eu/about-eu/eu-history/1945-1959/index_en.htm) [Accessed 20 May 2014]

Fédération des Experts Comptables Européens (FEE). (2000). The Auditor's Report in Europe. Available at: [http://www.fee.be/images/publications/auditing/Auditor\\_s\\_Report\\_in\\_Europe\\_00061632005101241.pdf](http://www.fee.be/images/publications/auditing/Auditor_s_Report_in_Europe_00061632005101241.pdf) [Accessed 20 May 2014]

Financial Stability Board (FSB). (n.d.1). Why are Standards Important? Available at: <https://www.financialstabilityboard.org/cos/wasi.htm> [Accessed 5 May 2014]

Financial Stability Board (FSB). (n.d.2). Mandate. Available at: <https://www.financialstabilityboard.org/about/mandate.htm> [Accessed 5 May 2014]

Financial Stability Board (FSB). (2012). Charter of the Financial Stability Board. Available at: [https://www.financialstabilityboard.org/publications/r\\_120809.pdf](https://www.financialstabilityboard.org/publications/r_120809.pdf) [Assessed 20 May 2014]

Foster, (2010) The decade's worst financial scandals. Available at: <http://www.foster.washington.edu/centers/facultyresearch/Pages/karpoff-scandals.aspx> [Accessed 20 May 2014]

International Auditing and Assurance Standards Board (IAASB). (2011). Enhancing the Value of Auditor Reporting: Exploring Options for Change. Available at: [http://www.ifac.org/sites/default/files/publications/exposure-drafts/CP\\_Auditor\\_Reporting-Final.pdf](http://www.ifac.org/sites/default/files/publications/exposure-drafts/CP_Auditor_Reporting-Final.pdf) [Accessed 1 April 2014]

International Auditing and Assurance Standards Board (IAASB). (2012). Improving the Auditor's Report. Available at: [http://www.ifac.org/sites/default/files/publications/files/Auditor\\_Reporting\\_Invitation\\_to\\_Comment-final\\_0.pdf](http://www.ifac.org/sites/default/files/publications/files/Auditor_Reporting_Invitation_to_Comment-final_0.pdf) [Accessed 1 April 2014]

International Auditing and Assurance Standards Board (IAASB). (2013). Reporting on Audited Financial Statements: Proposed New and Revised International Standards on Auditing (ISAs). Available at: <https://www.ifac.org/sites/default/files/publications/files/Complete%20ED,%20Reporting%20on%20Audited%20Financial%20Statements.pdf> [Accessed 1 April 2014]

International Federation of Accountants (IFAC). (n.d.). Background Information On The International Federation Of Accountants. Available at: <http://www.ifac.org/sites/default/files/publications/files/background-information-on-t.pdf> [Accessed 15 April 2014]

International Federation of Accountants (IFAC). (2013). 2012 Annual Report. Transparency And Accountability: Past, Present, Future. Available at: <http://viewer.zmags.com/publication/3b64b02c#/3b64b02c/4> [Accessed 15 May 2014]

International Federation of Accountants (IFAC). (2014a). Auditor Reporting – The IAASB's #1 Priority. Available at: <http://www.ifac.org/auditing-assurance/auditor-reporting-iaasbs-1-priority> [Accessed 10 May 2014]

International Federation of Accountants (IFAC). (2014b). Submitted Comment Letters, Available Online: <http://www.ifac.org/publications-resources/improving-auditor-s-report>, [Accessed 3 April 2014].

International Federation of Accountants (IFAC). (2014c). Submitted Comment Letters, Available Online: <http://www.ifac.org/publications-resources/enhancing-value-auditor-reporting-exploring-options-change> , [Accessed 3 April 2014].

International Federation of Accountants (IFAC). (2014d). Agenda Item 6A. Available at: <http://www.ifac.org/auditing-assurance/meetings/new-york-usa-0> [Accessed 3 April 2014].

International Federation of Accountants (IFAC). (2014e). The Clarified Standards. Available at: <http://www.ifac.org/auditing-assurance/clarity-center/clarified-standards> [Accessed 3 April 2014].

International Federation of Accountants (IFAC). (2014f). Agenda Item 4A. Available at: <http://www.ifac.org/auditing-assurance/meetings/san-francisco-ca-united-states> [Accessed 3 April 2014].

International Federation of Accountants (IFAC). (2014g). Meeting Summary. Available at: <http://www.ifac.org/auditing-assurance/meetings/orlando-florida> [Accessed 3 April 2014].

International Federation of Accountants (IFAC). (2014h). Agenda Item 4. Available at: <http://www.ifac.org/auditing-assurance/meetings/paris-france> [Accessed 3 April 2014].

International Federation of Accountants (IFAC). (2014i). Agenda Item 4 cover. Available at: <http://www.ifac.org/auditing-assurance/meetings/paris-france> [Accessed 3 April 2014].

International Federation of Accountants (IFAC). (2014j). Agenda Item 5A. Project Proposal. Available at: <http://www.ifac.org/auditing-assurance/meetings/los-angeles-california> [Accessed 3 April 2014].

International Federation of Accountants (IFAC). (2014k). History. Available at: <http://www.ifac.org/about-ifac/organization-overview/history> [Accessed 3 April 2014].

International Federation of Accountants (IFAC). (2014l). Frequently Asked Questions. Available at: <http://www.ifac.org/about-ifac/organization-overview/faq> [Accessed 3 April 2014].

International Federation of Accountants (IFAC). (2014m). Background Information On The International Federation Of Accountants. Available at: <http://www.ifac.org/sites/default/files/publications/files/background-information-on-t.pdf> [Accessed 3 April 2014].

International Federation of Accountants (IFAC). (2014n). International Auditing and Assurance Standards Board Fact Sheet. Available at: <https://www.ifac.org/sites/default/files/uploads/IAASB/IAASB%20FactSheet.pdf> [Accessed 3 April 2014]

International Federation of Accountants (IFAC). (2014o). Terms of Reference. Available at: <http://www.ifac.org/auditing-assurance/about-iaasb/terms-reference> [Accessed 3 April 2014].

International Federation of Accountants (IFAC). (2014p). About IAASB. <http://www.ifac.org/auditing-assurance/about-iaasb>. Available at: [Accessed 3 April 2014].

International Federation of Accountants (IFAC). (2014q) Members. Available at: <http://www.ifac.org/auditing-assurance/cag/members>. [Accessed 3 April 2014].

International Federation of Accountants (IFAC). (2014r). Forum Of Firms. Available at: <https://www.ifac.org/sites/default/files/uploads/TAC-FoF/Fact-Sheet-FoF-TAC.pdf> [Accessed 20 May]

International Federation of Accountants (IFAC). (2014s). CAG. Available at: <http://www.ifac.org/auditing-assurance/cag> [Accessed 20 May]

International Federation of Accountants (IFAC). (2014t). Meeting Summary. Available at: <https://www.ifac.org/auditing-assurance/meetings/brussels-belgium-0> [Accessed 20 May]

International Federation of Accountants (IFAC). (2014u). Agenda Item 5-B. Available at: <https://www.ifac.org/auditing-assurance/meetings/brussels-belgium-0> [Accessed 20 May]

International Federation of Accountants (IFAC). (2014v). Agenda Item 4-F. Available at: <https://www.ifac.org/auditing-assurance/meetings/50th-meeting-iaasb-march-12-16-2012-toronto-canada> [Accessed 20 May]

International Forum of Independent Audit Regulators (IFIAR). (2014). Report on 2013 Survey of Inspection Findings. Available at: [https://www.ifiar.org/IFIAR/media/Documents/IFIARMembersArea/MemberUpdates/IFIAR-Inspection-Survey-9-April-2014\\_1.pdf](https://www.ifiar.org/IFIAR/media/Documents/IFIARMembersArea/MemberUpdates/IFIAR-Inspection-Survey-9-April-2014_1.pdf) [Accessed 1 May 2014]

International Forum of Independent Audit Regulators (IFIAR). (n.d.). About Us. Available at: <https://www.ifiar.org/About-Us.aspx> [Accessed 6 May 2014]

International Organization of Securities Commissions (IOSCO). (2009). IOSCO Statement on International Auditing Standards. Available at: <http://www.iosco.org/library/statements/pdf/statements-7.pdf> [Accessed 14 April 2014]

International Organization of Securities Commissions (IOSCO). (n.d.). The International Organization of Securities Commissions. Available at: <http://www.iosco.org/about/> [Accessed 4 May 2014]

International Organization of Securities Commissions (IOSCO). (2014). The Monitoring Group. Available at: [http://www.iosco.org/monitoring\\_group/index.cfm](http://www.iosco.org/monitoring_group/index.cfm) [Accessed 4 May 2014]

Institute for Work & Health (IWH). (2008). What researchers mean by... primary data and secondary data. Available at: <http://www.iwh.on.ca/wrmb/primary-data-and-secondary-data> [Accessed 10 May 2014]

Institute of Chartered Accountants Australia (ICAA), (2013). IAASB plans to restructure audit reports. Available at: <http://www.charteredaccountants.com.au/Industry-Topics/Audit-and-assurance/Current-issues/Clarity-project/News-and-updates/IAASB-plans-to-restructure-audit-reports.aspx> [Accessed 20 May 2014]

IOSCO Technical Committee (2009). Auditor Communications: Consultation Report. Available at: <http://www.iosco.org/library/pubdocs/pdf/IOSCOPD303.pdf> [Accessed 1 May 2014]

- IOSCO Technical Committee (2010). Comments Received in response to Consultation Reports on Issues Pertaining to the Audit of Publicly Listed Companies. Available at: <http://www.iosco.org/library/pubdocs/pdf/IOSCOPD337.pdf> [Accessed 1 May 2014]
- Indiana University Bloomington (IUB). (2010). Identifying Primary and Secondary Sources. Available at: <http://www.libraries.iub.edu/?pageId=1002226> [Accessed 1 May 2014]
- Lynch, S.N. (2014). Audits around the world are riddled with problems -survey. *Reuters*, 10 April, Available at <http://www.reuters.com/article/2014/04/10/regulations-auditor-survey-idUSL1N0MW0S520140410> [Accessed 6 May 2014]
- Maglio, R (2011). A Content based Analysis of Comment Letters on the IASB Discussion Paper “Financial Instruments with Characteristics of Equity”. Available at: [http://papers.ssrn.com/sol3/papers.cfm?abstract\\_id=1795982](http://papers.ssrn.com/sol3/papers.cfm?abstract_id=1795982) [Accessed 10 May 2014]
- Public Interest Oversight Board (PIOB). (n.d.1). Origins of the PIOB. Available at: <http://www.ipiob.org/index.php/origins-of-the-piob> [Accessed 14 April 2014]
- Public Interest Oversight Board (PIOB). (n.d.2). What is the PIOB. Available at: <http://www.ipiob.org/index.php/what-is-the-piob> [Accessed 14 April 2014]
- Public Interest Oversight Board (PIOB). (2011). Concept Release on Possible Revisions to PCAOB Standards. Available at: [http://pcaobus.org/Rules/Rulemaking/Docket034/Concept\\_Release.pdf](http://pcaobus.org/Rules/Rulemaking/Docket034/Concept_Release.pdf) [Accessed 1 May 2014]
- Public Company Accounting Oversight Board (PCAOB). (2013). The Auditor’s Report on an Audit of Financial Statements When the Auditor Expresses an Unqualified Opinion; The Auditor’s Responsibilities Regarding Other Information in Certain Documents Containing Audited Financial Statements and The Related Auditor’s Report; and Related Amendments to PCAOB Standards. Available at: [http://pcaobus.org/Rules/Rulemaking/Docket034/Release\\_2013-005\\_ARM.pdf](http://pcaobus.org/Rules/Rulemaking/Docket034/Release_2013-005_ARM.pdf) [Accessed 5 May 2014]
- Public Accounting Oversight Board (PCAOB). (2014a). Non-U.S. Firm Inspections. Available at: <http://pcaobus.org/Pages/default.aspx> [Accessed 20 May 2014]
- Public Accounting Oversight Board (PCAOB). (2014b). About the PCAOB. Available at: <http://pcaobus.org/About/Pages/default.aspx> [Accessed 20 May 2014]
- Pucheta, M.C. & Fakhfakh, M. (2005) The Measurement of Compliance with International ISA700: The Case of Audit Reports Published by the Big Accounting Firms in Tunisia, working paper no.2005-19, Universitat Jaume I; University of Sfax Available at: <http://www.ivie.es/downloads/docs/wpasad/wpasad-2005-19.pdf> [Accessed 14 May 2014]
- PwC (2013). Auditor reporting: An overview of global developments. Available at: [http://www.pwc.com/en\\_GX/gx/audit-services/publications/assets/pwc-auditor-reporting-an-overview-of-global-developments.pdf](http://www.pwc.com/en_GX/gx/audit-services/publications/assets/pwc-auditor-reporting-an-overview-of-global-developments.pdf) [Accessed 5 May 2014]
- Sawers, A. (2012). Suddenly, Audit Reports Get Sexy. CFO. 27 June, Available at: <http://ww2.cfo.com/auditing/2012/06/suddenly-audit-reports-get-sexy/> [Accessed 20 May 2014]

Schilder, A. (2013). The Evolving Role of Auditors and Auditor Reporting, Available at: <http://www.ifac.org/sites/default/files/news/files/Prof-Schilder-2013-CReCER-Speech-Auditor-Reporting.pdf> [Accessed 15 May 2014]

Strawser R.H. (1990). The new auditor's report: will it close the expectations gap in communications? CPA Journal. <http://www.nysscpa.org/cpajournal/old/08526920.htm> [Accessed 15 May 2014]

Sumutka, A.R. (1989). Implementing SAS 58: reports on audited financial statements. *CPA Journal*. <http://www.nysscpa.org/cpajournal/old/07085934.htm> [Accessed 15 May 2014]

World Bank (2004). Reports on the Observance of Standards and Codes (ROSC): Overview of the ROSC Accounting and Auditing Program. Available at: [http://www.worldbank.org/ifa/rosc\\_aa\\_overview.pdf](http://www.worldbank.org/ifa/rosc_aa_overview.pdf) [Accessed 5 May 2014]

World Bank (2014a). About. Available at: <http://www.worldbank.org/en/about> [Accessed 20 May 2014]

World Bank (2014b). Member Countries. Available at: <http://www.worldbank.org/en/about/leadership/members#1> [Accessed 20 May 2014]

World Finance (2011). The Parmalat Scandal. Available at: <http://www.worldfinance.com/home/special-reports-home/the-parmalat-scandal> [Accessed 20 May 2014]

## **Appendix 1. Investigated Issues in Comment Letters**

1. The proposal of a new section of an Auditor Commentary
  - The general opinion about the proposal about an Auditor Commentary
  - Support for audit commentary about the audit and the audited entity
  - Support for audit commentary on the audit procedures
  - Other suggestions to improve the auditor report
2. Emphasis of Matter and Other Matter paragraphs
  - Support for an expanded use of these paragraphs
  - Support for the Auditor Commentary to replace these paragraphs
  - Support for these paragraphs to be retained even though the introduction of Auditor Commentary
3. Opinions regarding which entities the proposed Auditor Commentary should be required for and if it should be voluntary for the entities that it is not required for.
4. Expressed views regarding information about applied materiality should be included or not in the Auditor Commentary.
5. Expressed views if disclosures in the Auditor Commentary should be matters that have been communicated with Those Charge With Governance.

## Appendix 2. The Selected Sample of Respondents

	Abbreviations	Name	CP	ITC
<b>Investors and Analysts</b>				
	BR	BlackRock, Inc (Investment Manager)	1	1
	EUMEDION	Eumedion (Dutch Institutional Investors)	1	1
	HEOS	Hermes Equity Ownership Services	1	1
	S&P	Standard & Poor's Ratings Services	0	1
	ICGN	International Corporate Governance Network	1	1
<b>Preparers of Financial Statements</b>				
	BusinessEurope	BusinessEurope	0	1
	100 Group UK	The Hundred Group of Finance Directors (UK)	1	1
	CNRL	Canadian Natural Resources Limited	1	1
	Group of 100 A	Group of 100 (Australia)	0	1
<b>Regulators and Oversight Authorities</b>				
	BCBS	Basel Committee on Banking Supervision	1	1
	ESMA *	European Securities and Markets Authority	1	1
	IOSCO	International Organization of Securities Commissions	1	1
	IAIS	International Association of Insurance Supervisors	1	1
	EAIG	European Audit Inspection Group (21 European Audit Regulators)17	0	1
	World Bank	World Bank	0	1
<b>Profession</b>				
	Deloitte	Deloitte Touche Tohmatsu Limited	1	1
	EY	Ernst & Young Global	1	1
	KPMG	KPMG IFRG Limited	1	1
	PWC	PwC	1	1
	Mazars	Mazars	1	1
	SRA	SRA (Netherlands Network)	0	1
	BT	Baker Tilly	1	1
<b>TCWG</b>				
	IIA	Institute of Internal Auditors	1	1
	OECD	Organisation for Economic Co-operation and Development	0	1
	AICD	Australian Institute of Company Directors	1	1
<b>National Auditing Standard Setters</b>				
	UK FRC*	Financial Reporting Council – UK	0	1
	ASB	American Institute of Certified Public Accountants' Auditing Standards Board	0	1
	CAASB	Canadian Auditing and Assurance Standards Board	1	1
	JICPA	Japanese Institute of Certified Public Accountants	1	1
<b>Member Bodies and Other Professional Organizations</b>				
	FEE*	Fédération des Experts Comptables Européens	1	1
	EFAA	European Federation of Accountants and Auditors for SMEs	1	1
	IDW*	Institut der Wirtschaftsprüfer	0	1
	ACCA*	Association of Chartered Certified Accountants	1	1
	ICAEW*	Institute of Chartered Accountants in England and Wales	1	1
	ICPAS	Institute of Certified Public Accountants of Singapore	0	1
	CAQ*	Center for Audit Quality	1	1
	ZICA	Zambia Institute of Chartered Accountants	1	1
	ICAN	Institute of Chartered Accountants of Nigeria	0	1
<b>Public Sector Organizations</b>				
	CNAO	National Audit Office (China)	0	1
	AGNZ	Office of the Controller and Auditor-General of New Zealand	1	1
	NAOS	National Audit Office (Sweden)	0	1
			27	41



### **Appendix 3. The Independent Audit Report Issued 1994**

#### **Auditor's Report**

(Appropriate Addressee)

We have audited the accompanying balance sheet of the ABC Company as of December 31, 19X1, and the related statements of income, and cash flows for the year then ended. These financial statements are the responsibility of the Company's management. Our responsibility is to express an opinion on these financial statements based on our audit.

We conducted our audit in accordance with International Standards on Auditing (or refer to relevant national standards or practices). Those Standards require that we plan and perform the audit to obtain reasonable assurance about whether the financial statements are free of material misstatement. An audit includes examining, on a test basis, evidence supporting the amounts and disclosures in the financial statements. An audit also includes assessing the accounting principles used and significant estimates made by management, as well as evaluating the overall financial statement presentation. We believe that our audit provides a reasonable basis for our opinion.

In our opinion, the financial statements give a true and fair view of (or 'present fairly, in all material respects,') the financial position of the Company as of December 31, 19X1, and of the results of its operations and its cash flows for the year then ended in accordance with ...' (and comply with ...).

Auditor  
Date  
Address

Source: FEE, 2000, p. 12,

## **Appendix 4. The Current Independent Audit Report, ISA 700**

### **INDEPENDENT AUDITOR'S REPORT**

[Appropriate Addressee]

#### **Report on the Financial Statements**

We have audited the accompanying financial statements of ABC Company, which comprise the statement of financial position as at December 31, 20X1, and the statement of comprehensive income, statement of changes in equity and statement of cash flows for the year then ended, and a summary of significant accounting policies and other explanatory information.

#### **Management's Responsibility for the Financial Statements**

Management is responsible for the preparation and fair presentation of these financial statements in accordance with International Financial Reporting Standards, and for such internal control as management determines is necessary to enable the preparation of financial statements that are free from material misstatement, whether due to fraud or error.

#### **Auditor's Responsibility**

Our responsibility is to express an opinion on these financial statements based on our audit. We conducted our audit in accordance with International Standards on Auditing. Those standards require that we comply with ethical requirements and plan and perform the audit to obtain reasonable assurance about whether the financial statements are free from material misstatement.

An audit involves performing procedures to obtain audit evidence about the amounts and disclosures in the financial statements. The procedures selected depend on the auditor's judgment, including the assessment of the risks of material misstatement of the financial statements, whether due to fraud or error. In making those risk assessments, the auditor considers internal control relevant to the entity's preparation and fair presentation of the financial statements in order to design audit procedures that are appropriate in the circumstances, but not for the purpose of expressing an opinion on the effectiveness of the entity's internal control. An audit also includes evaluating the appropriateness of accounting policies used and the reasonableness of accounting estimates made by management, as well as evaluating the overall presentation of the financial statements.

We believe that the audit evidence we have obtained is sufficient and appropriate to provide a basis for our audit opinion.

#### **Opinion**

In our opinion, the financial statements present fairly, in all material respects, (or give a true and fair view of) the financial position of ABC Company as at December 31, 20X1, and (of) its financial performance and its cash flows for the year then ended in accordance with International Financial Reporting Standards.

#### **Report on Other Legal and Regulatory Requirements**

[Form and content of this section will vary depending on the nature of the other reporting responsibilities.]

[Auditor's signature]

[Date of the auditor's report]

[Auditor's address]

## **Appendix 5. Member Organizations of IAASB's Consultative Advisory Group (CAG)**

- Asian Financial Executives Institutes
- Associação Brasileira de Instituições Financeiras de Desenvolvimento
- Basel Committee on Banking Supervision
- BUSINESSEUROPE
- CFA Institute
- European Commission
- European Federation of Accountants and Auditors for SMEs
- European Financial Executives Institutes
- Fédération des Experts Comptables Européens
- Gulf States Regulatory Authorities
- Information Systems Audit and Control Association
- Institute of Internal Auditors
- International Accounting Standards Board
- International Actuarial Association
- International Association of Insurance Supervisors
- International Bar Association
- International Corporate Governance Network
- International Organization of Securities Commissions
- International Organization of Supreme Audit Institutions
- International Valuation Standards Council
- Islamic Financial Services Board
- Japan Securities Dealers Association
- National Association of State Boards of Accountancy
- North American Financial Executives Institutes
- Organisation for Economic Cooperation and Development
- Sri Lanka Accounting and Auditing Standards Monitoring Board
- United Nations Conference on Trade & Development
- World Bank
- World Federation of Exchanges

### **Observers**

- Financial Services Agency, Japan
- International Monetary Fund
- U.S. Public Company Accounting Oversight Board

Source: IFAC, 2014q

## Appendix 6. The Proposed Illustrative Audit Report

### INDEPENDENT AUDITOR'S REPORT

To the Shareholders of ABC Company [or Other Appropriate Addressee]

#### Report on the Audit of the Consolidated Financial Statements<sup>3</sup>

##### Opinion

In our opinion, the accompanying consolidated financial statements present fairly, in all material respects, *(or give a true and fair view of)* the consolidated financial position of ABC Company and its subsidiaries (the Group) as at December 31, 20X1, and *(of)* their consolidated financial performance and their consolidated cash flows for the year then ended in accordance with International Financial Reporting Standards (IFRSs).

We have audited the consolidated financial statements of the Group, which comprise the consolidated statement of financial position as at December 31, 20X1, and the consolidated statement of comprehensive income, consolidated statement of changes in equity and consolidated statement of cash flows for the year then ended, and notes to the consolidated financial statements, including a summary of significant accounting policies.

##### Basis for Opinion

We conducted our audit in accordance with International Standards on Auditing (ISAs). Our responsibilities under those standards are further described in the *Auditor's Responsibilities for the Audit of the Consolidated Financial Statements* section of our report. We are independent of the Group within the meaning of *[indicate relevant ethical requirements or applicable law or regulation]* and have fulfilled our other responsibilities under those ethical requirements. *(see Question 11)* We believe that the audit evidence we have obtained is sufficient and appropriate to provide a basis for our opinion.

##### Key Audit Matters *(see Questions 1-8)*

Key audit matters are those matters that, in our professional judgment, were of most significance in our audit of the consolidated financial statements. Key audit matters are selected from the matters communicated with *[those charged with governance]*, but are not intended to represent all matters that were discussed with them. Our audit procedures relating to these matters were designed in the context of our audit of the consolidated financial statements as a whole. Our opinion on the consolidated financial statements is not modified with respect to any of the key audit matters described below, and we do not express an opinion on these individual matters.

*The four specific topics and content presented below are purely for illustrative purposes. This section would be tailored to the facts and circumstances of the individual audit engagement and the entity. Accordingly, the IAASB has intentionally drafted these examples in a manner that illustrates that Key Audit Matters will vary in terms of the number and selection of topics addressed and the nature in which they may be described, and are intended to be consistent with the disclosures in the entity's consolidated financial statements.*

##### *Goodwill*

Under IFRSs, the Group is required to annually test the amount of goodwill for impairment. This annual impairment test was significant to our audit because the assessment process is complex and highly judgmental and is based on assumptions that are affected by expected future market or economic conditions, particularly those in *[Countries X and Y]*. As a result, our audit procedures included, among others, using a valuation expert to assist us in evaluating the assumptions and methodologies used by the Group, in particular those relating to the

<sup>3</sup> The sub-title "Report on the Audit of the Consolidated Financial Statements" is unnecessary in circumstances when the second sub-title "Report on Other Legal and Regulatory Requirements" is not applicable.

forecasted revenue growth and profit margins for *[name of business lines]*. We also focused on the adequacy of the Group's disclosures about those assumptions to which the outcome of the impairment test is most sensitive, that is, those that have the most significant effect on the determination of the recoverable amount of goodwill. The Group's disclosures about goodwill are included in Note 3, which specifically explains that small changes in the key assumptions used could give rise to an impairment of the goodwill balance in the future.

#### *Valuation of Financial Instruments*

The Group's disclosures about its structured financial instruments are included in Note 5. The Group's investments in structured financial instruments represent *[x%]* of the total amount of its financial instruments. Because the valuation of the Group's structured financial instruments is not based on quoted prices in active markets, there is significant measurement uncertainty involved in this valuation. As a result, the valuation of these instruments was significant to our audit. The Group has determined it is necessary to use an entity-developed model to value these instruments, due to their unique structure and terms. We challenged management's rationale for using an entity-developed model, and discussed this with *[those charged with governance]*, and we concluded the use of such a model was appropriate. Our audit procedures also included, among others, testing management's controls related to the development and calibration of the model and confirming that management had determined it was not necessary to make any adjustments to the output of the model to reflect the assumptions that marketplace participants would use in similar circumstances.

#### *Acquisition of XYZ Business*

As described in Note 2, in December 20X1, the Group completed the acquisition of XYZ Business. XYZ Business was a division of a large private company. As of December 31, 20X1, the Group has completed the initial acquisition accounting on a preliminary basis. The Group will finalize the initial acquisition accounting during 20X2, and the amounts recorded as of December 31, 20X1 could change. We focused on this transaction because it is material to the consolidated financial statements as a whole and the fact that values had not previously been assigned to the division as a standalone operation. In addition, determining the assumptions that underlie the initial acquisition accounting and the useful lives associated with the acquired intangible assets involves significant management judgment given the nature of the *[name of industry]*.

#### *Revenue Recognition Relating to Long-Term Contracts*

The terms and conditions of the Group's long-term contracts in its *[name of segment]* affect the revenue that the Group recognizes in a period, and the revenue from such contracts represents a material amount of the Group's total revenue. The process to measure the amount of revenue to recognize in the *[name of industry]*, including the determination of the appropriate timing of recognition, involves significant management judgment. We identified revenue recognition of long-term contracts as a significant risk requiring special audit consideration. This is because side agreements may exist that effectively amend the original contracts, and such side agreements may be inadvertently unrecorded or deliberately concealed and therefore present a risk of material misstatement due to fraud. In addition to testing the controls the Group has put in place over its process to enter into and record long-term contracts and other audit procedures, we considered it necessary to confirm the terms of these contracts directly with customers and testing journal entries made by management related to revenue recognition. Based on the audit procedures performed, we did not find evidence of the existence of side agreements. The Group's disclosures about revenue recognition are included in the summary of significant accounting policies in Note 1, as well as Note 4.

### **Going Concern** (see Questions 9–10)

The consolidated financial statements of the Group have been prepared using the going concern basis of accounting. The use of this basis of accounting is appropriate unless management either intends to liquidate the Group or to cease operations, or has no realistic alternative but to do so. As part of our audit of the consolidated financial statements, we have concluded that management's use of the going concern basis of accounting in the preparation of the Group's consolidated financial statements is appropriate.

Management has not identified a material uncertainty that may cast significant doubt on the Group's ability to continue as a going concern, and accordingly none is disclosed in the consolidated financial statements of the Group. Based on our audit of the consolidated financial statements of the Group, we also have not identified such a material uncertainty. However, neither management nor the auditor can guarantee the Group's ability to continue as a going concern.

### **Other Information**

*[The illustrative wording for this section is subject to the IAASB's finalization of proposed ISA 720 (Revised). The content of this section may include, among other matters: (a) a description of the auditor's responsibilities with respect to other information; (b) identification of the document(s) available at the date of the auditor's report that contain the other information to which the auditor's responsibilities apply; (c) a statement addressing the outcome of the auditor's work on the other information; and (d) a statement that the auditor has not audited or reviewed the other information and, accordingly, does not express an audit opinion or a review conclusion on it.]*

### **Responsibilities of [Management<sup>4</sup> and Those Charged with Governance or other appropriate terms] for the Consolidated Financial Statements**

Management is responsible for the preparation and fair presentation of these consolidated financial statements in accordance with IFRSs,<sup>5</sup> and for such internal control as management determines is necessary to enable the preparation of consolidated financial statements that are free from material misstatement, whether due to fraud or error. *[Those charged with governance]* are responsible for overseeing the Group's financial reporting process. (see Question 13)

### **Auditor's Responsibilities for the Audit of the Consolidated Financial Statements** (see Question 13)

The objectives of our audit are to obtain reasonable assurance about whether the consolidated financial statements as a whole are free from material misstatement, whether due to fraud or error, and to issue an auditor's report that includes our opinion. Reasonable assurance is a high level of assurance, but is not a guarantee that an audit conducted in accordance with ISAs will always detect a material misstatement when it exists. Misstatements can arise from fraud or error and are considered material if, individually or in the aggregate, they could reasonably be expected to influence the economic decisions of users taken on the basis of these consolidated financial statements.

*The remaining material in this section can be located in an Appendix to the auditor's report (see paragraph 39 of proposed ISA 700 (Revised)). When law, regulation or national auditing standards expressly permits, reference can be made to a website of an appropriate authority that contains the description of the auditor's responsibilities, rather than including this material in the auditor's report (see paragraph 40 of proposed ISA 700 (Revised)).*

<sup>4</sup> Throughout the illustrative auditor's reports in the Proposed ISAs, the term management may need to be replaced by another term that is appropriate in the context of the legal framework in the particular jurisdiction. For example, those charged with governance, rather than management, may have these responsibilities.

<sup>5</sup> Where management's responsibility is to prepare financial statements that give a true and fair view, this may read: "Management is responsible for the preparation of consolidated financial statements that give a true and fair view in accordance with IFRSs, and for such ..."

As part of an audit in accordance with ISAs, we exercise professional judgment and maintain professional skepticism throughout the planning and performance of the audit. We also:

- ❖ Identify and assess the risks of material misstatement of the consolidated financial statements, whether due to fraud or error, design and perform audit procedures responsive to those risks, and obtain audit evidence that is sufficient and appropriate to provide a basis for our opinion. The risk of not detecting a material misstatement resulting from fraud is higher than for one resulting from error, as fraud may involve collusion, forgery, intentional omissions, misrepresentations, or the override of internal control.
- ❖ Obtain an understanding of internal control relevant to the audit in order to design audit procedures that are appropriate in the circumstances, but not for the purpose of expressing an opinion on the effectiveness of the entity's internal control.<sup>6</sup>
- ❖ Evaluate the appropriateness of accounting policies used and the reasonableness of accounting estimates and related disclosures made by management.
- ❖ Evaluate the overall presentation, structure and content of the consolidated financial statements, including the disclosures, and whether the consolidated financial statements represent the underlying transactions and events in a manner that achieves fair presentation.
- ❖ Obtain sufficient appropriate audit evidence regarding the financial information of the entities and business activities within the group to express an opinion on the consolidated financial statements. We are responsible for the direction, supervision and performance of the group audit. We remain solely responsible for our audit opinion.

We are required to communicate with [*those charged with governance*] regarding, among other matters, the planned scope and timing of the audit and significant audit findings, including any significant deficiencies in internal control that we identify during our audit.

We are also required to provide [*those charged with governance*] with a statement that we have complied with relevant ethical requirements regarding independence, and to communicate with them all relationships and other matters that may reasonably be thought to bear on our independence, and where applicable, related safeguards.

#### **Report on Other Legal and Regulatory Requirements**

*[The form and content of this section of the auditor's report would vary depending on the nature of the auditor's other reporting responsibilities prescribed by local law, regulation, or national auditing standards. Depending on the matters addressed by other law, regulation or national auditing standards, national standard setters may choose to combine reporting on these matters with reporting as required by the ISAs (shown in the Report on the Audit of the Consolidated Financial Statements section), with wording in the auditor's report that clearly distinguishes between reporting required by the ISAs and other reporting required by law or regulation. (see Question 13)]*

The engagement partner responsible for the audit resulting in this independent auditor's report is [*name*]. (see Question 12)

*[Signature in the name of the audit firm, the personal name of the auditor, or both, as appropriate for the particular jurisdiction]*

*[Auditor Address]*

*[Date]*

<sup>6</sup> This sentence would be modified, as appropriate, in circumstances when the auditor also has responsibility to issue an opinion on the effectiveness of internal control in conjunction with the audit of the consolidated financial statements.