

Master Thesis

Design of a Rise Support to be integrated in the HOBBIT Robot

Gerardo Cedeño

Certec, Division of Rehabilitation Engineering Research

Department of Design Sciences

Faculty of Engineering LTH • Lund University • 2014



LUND UNIVERSITY

Design of a Rise Support to be integrated in the HOBBIT Robot

Gerardo Cedeño

Certec, Division of Rehabilitation Engineering Research • Department of Design Sciences

Faculty of Engineering LTH • Lund University • 2014

Certec, Division of Rehabilitation Engineering research
Department of Design Sciences
Faculty of Engineering LTH, Lund University
P.O. Box 118
SE-221 00 Lund
Sweden

Certec report 6:2014

PREFACE

I am really grateful with Håkan Eftring for the opportunity of being involved in this project. I would like to thank Ingrid Svensson for the unconditional assistance in the thesis. And finally, I want to dedicate this dissertation to my mother, father, aunt Carolina Bergman and all my friends who have supported me throughout the process.

Lund, June 2014

Gerardo Cedeño

ABSTRACT

The latest research regarding the world population ageing developed by the United Nations demonstrates how fast the proportion of people over 65 years old is increasing [1]. Thus the demand for elderly care services is growing. This environment encouraged the creation of the main idea of the HOBBIT project which is to build a “service robot” with the purpose of taking care of elderly people allowing him or her to have an independent life. This robot includes many tasks such as reducing the falling risk which is one of the most common accidents in elderly people (30% of elderly people fall at least once a year) [2] by removing dangerous object of the floor.

The general objective of this master thesis was to design a rising support to help older people to stand up, in order to decrease the risk of falling. The device should be integrated in the latest version of the HOBBIT robot project financed by the European Commission.

After the literature review and the generation of ideas, the main conclusion was that giving stability to the lower body by adding a support for one or both knees, and a handle for one arm is enough to help the user to place his or her body in a good position to perform the Sit-to-Stand movement and gives the required balance at the same time. Thus, with the purpose of getting information of the behavior of the structure and the body of the user during the movement, a model was built with two provisional supports. This structure has displacement sensors which measured the forces generated during the motion. On the other hand, during the tests in the laboratory the movement was recorded with the motion capture system.

The main task of the project was reached successfully, a rise support was designed and tested and the verification process (using Matlab and OpenSim models) demonstrated the feasibility of including this design in the HOBBIT project. The model of the rise-up device improves the stability of the user during the Sit-to Stand movement, keeping the balance of the HOBBIT robot. The position of the supports forces the user to a good initial position for the movement, reducing the risk, of falling and the moment required in hips and knees.

Keywords: Sit-to-Stand, HOBBIT, robot, balance, fall risk, OpenSim, supports.

INDEX

1	Introduction	1
1.1	Background	1
1.2	Problem discussion	5
1.3	Justification	6
1.4	Objectives	6
1.5	Restrictions	7
2	Method	8
3	Theoretical framework	10
3.1	The HOBBIT Project	10
3.2	The Sit-to-Stand movement and products	11
3.2.1	Determinants review	12
3.2.2	Movement techniques and assistance	13
3.2.3	Developed products	14
3.3	Motion capture system	19
3.4	OpenSim	20
4	Concept Design	22
4.1	Necessity	22
4.2	Functional analysis	22
4.2.1	The black box	23
4.2.2	Diagram of functions	23
4.2.3	Process Diagram	24
4.3	Technical specifications	24
4.3.1	Functional characteristics	25
4.3.2	Environmental conditions	25
4.3.3	User characteristics	25
4.3.4	Interface	25
4.4	Generation of ideas	26
4.4.1	First option	26
4.4.2	Second option	27
4.5	Evaluating process	28
5	Data collection	30
5.1	Laboratory set-up	30

5.2	Force measurement	31
5.3	Motion capture system.....	37
5.4	Surveys.....	38
5.5	Data collection protocol.....	39
6	Models and validation process	40
6.1	OpenSim model	40
6.1.1	Importing the motion data	40
6.1.2	Creating the model	41
6.1.3	Scaling and inverse Kinematic tools	42
6.2	Stability model and spatial distribution	43
7	Results and Analysis	48
7.1	Laboratory results	48
7.1.1	Force values.....	48
7.1.2	Coordinate position	53
7.2	Kinematic study.....	53
7.3	Stability study	58
7.4	Elderly people tests.....	63
7.5	Final design summary	64
8	Conclusion.....	67
9	Appendix	68
10	References	70

List of figures

Figure 1: Total fertility rate and life expectancy at birth among the last 64 years [1]	2
Figure 2: Total fertility rate for different development levels of countries around the world [1]...	2
Figure 3: Distribution of population groups aged over 60, 70 and 80 years [1]	3
Figure 4: Latest model of the HOBBIT robot [6].....	10
Figure 5: Sit-to-Stand movement	11
Figure 6: The beginning of the second phase of the Sit-to-Stand movement [12].....	13
Figure 7: The beginning of the second phase of the Sit-to-Stand movement with a carer [12]....	14
Figure 8: Latest model of the 2.1.2.1 Vancare Vera II [13]	15
Figure 9: Latest model of the Handicare ReTurn7100 [14]	16
Figure 10: Latest model of the Handicare QuickMove [15]	17
Figure 11: Las model of robot Suit HAL [16].....	18
Figure 12: A common motion capture system set-up [18].....	19
Figure 13: Screenshot of the interface of OpenSim showing several tools [19]	21
Figure 14: Black Box diagram to define inputs and outputs of the process the device should complete	23
Figure 15: Diagram of functions	23
Figure 16: Diagram of the process required to reach a standing up position	24
Figure 17: Option 1	26
Figure 18: Option 2	27
Figure 19: Germund Larsson's proposal for the distances of the supports [20]	29
Figure 20: Measurement prototype.....	31
Figure 21: Older device with the measuring sensors included.....	32
Figure 22: Displacement sensors model.....	33
Figure 23: Noise reduction in the sensor's output	34
Figure 24: Handle with sensors integrated	35
Figure 25: Measuring direction	36
Figure 26: Knee support (the knee pushes on the flat surface of the triangular part, which needs to be modified for the final product)	36
Figure 27: Motion capture system	37
Figure 28: Laboratory set-up	38
Figure 29: .trc file editing.....	40

Figure 30: The markers distribution at the laboratory is shown to the left and the markers OpenSim preview to the right.....	41
Figure 31: View of the editing process of an OpenSim model	42
Figure 32: Physical model to study the balance of the HOBBIT	43
Figure 33: Position of the wheels in the base plate	44
Figure 34: Physical model to study the balance of the HOBBIT with the supports placed in the lateral side.....	47
Figure 35: Example of the results of the force measuring process (pushing handle).....	49
Figure 36: Force applied to the supports, worst case (pulling)	50
Figure 37: Force applied to the supports, worst case (pushing)	51
Figure 38: Results of the force for the pulling case for two different users	52
Figure 39: Preview of the OpenSim model with the handle.....	54
Figure 40: Animation resulted from the inverse kinematic tool.....	55
Figure 41: Elbow flexion and handle angles	56
Figure 42: θ angle Vs time for pushing and pulling case	57
Figure 43: δ angle Vs time for pushing and pulling case	57
Figure 44: DCL of the physical model of the proposal	59
Figure 45: Example of the output of the Matlab code.....	60
Figure 46: Optimization process for the β angle	61
Figure 47: Safety area for the final proposal	62
Figure 48: Final proposal integrated to the HOBBIT.....	65
Figure 49: Pictures sequence of the interaction of the user with the HOBBIT and the final proposal	66

List of tables

Table 1: Determinants of the Sit-to-Stand movement [11]	12
Table 2: Decision matrix	28
Table 3: K values for displacement sensors	34
Table 4: Maximal values of the force.....	52
Table 5: Critical values for δ and θ angles	58
Table 6: Proposal for the physical distances of the support and center of mass	62

NOMENCLATURE

Symbols

- p_1 : Contact point with the ground of the caster wheel
- p_2 and p_3 : Contact point with the ground of the two bigger wheels
- C1: Knee support
- C2: Hand support
- CM: Center of mass of the robot
- O: Origin of the coordinates
- X_{cm} , Y_{cm} and Z_{cm} : Coordinates of the center of mass
- X_{c1} , Y_{c1} and Z_{c1} : Coordinates of the knee support
- X_{c2} , Y_{c2} and Z_{c2} : Coordinates of the hand support
- d_1, d_2 and d_3 : distances to determine the position of the contact points with the ground
- W: Weight of the robot
- N_1, N_2 and N_3 : Normal forces generated in the contact points with the ground
- F_{r1}, F_{r2} and F_{r3} : Friction forces in Z direction
- F_k is the force applied in the knee support
- F_h is the force applied in the hand support
- Θ : Angle of F_h to the horizontal
- β : Angle of F_k to the horizontal
- α : Rotation of the caster wheel (small wheel)
- δ : Elbow flexion angle

1 INTRODUCTION

This first chapter gives an overview of the subject and an introduction to the thesis.

1.1 BACKGROUND

It is known that the twentieth century is defined by many characteristics. One of them is the increase of the older people population. This phenomenon is called the world population ageing. The United Nations establishes [1] that the percentage of elderly people (more than 60 years old) is increasing at the same time as the proportion of young people (under 15 years old) is decreasing. It is expected for 2050 to find a bigger amount of older than young people in the world; it would be for the first time in humanity's history.

There are two demographic determinants for the world population ageing that defines the current situation; the first one is the decrease in fertility, followed by the mortality decline. The total fertility rate has been bigger in less developed regions of the world, at the same time the life expectancy at birth is lower in the same places if they are compared with more developed regions. That is the reason why least developed countries have a bigger proportion of young than older people. But it doesn't mean that it is not changing. The United Nations reports show how the parentage of elderly people is increasing in every country around the world.

The Figure 1 and Figure 2 are presented in order to facilitate the understanding of the trend followed by the world population ageing among the last 64 years described above.

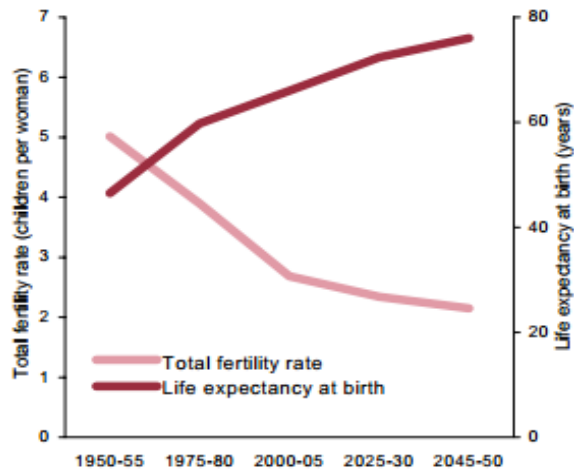

Figure 1: Total fertility rate and life expectancy at birth among the last 64 years

[1]

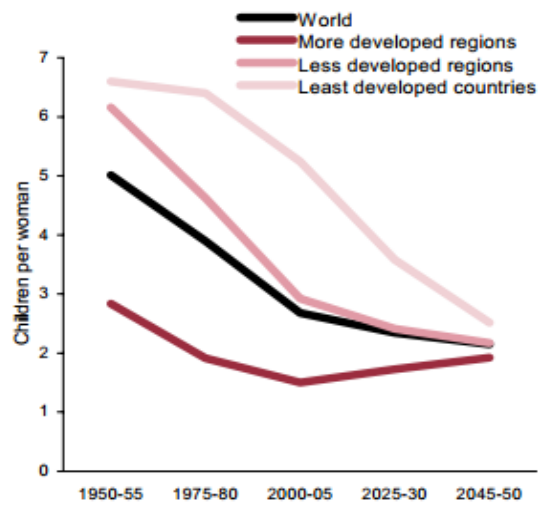

Figure 2: Total fertility rate for different development levels of countries around the world

[1]

Another characteristic that is changing with the years is the internal composition of the older people group. To explain this process it is easier to use the following example. Sixty years ago, only 6.67% of the elderly people were above 80 years old. Nowadays, this percentage has increased to 11.11% and for 2050 is expected to have up to 20% of elderly people aged above 80 [1]. This information is easily explained in the United Nations graph (Figure 3).

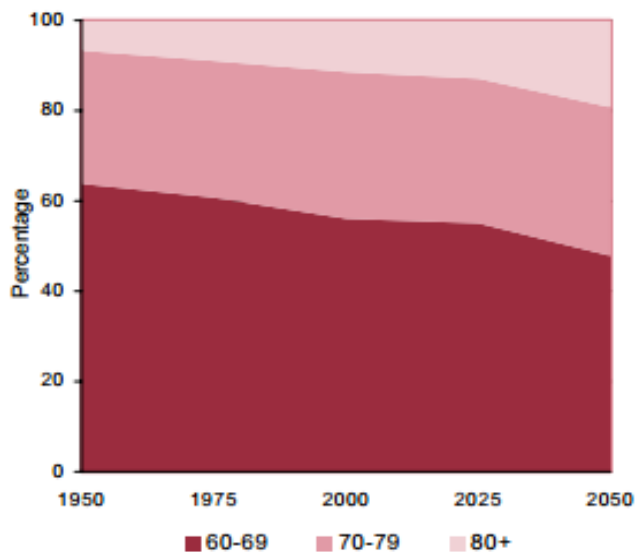

Figure 3: Distribution of population groups aged over 60, 70 and 80 years [1]

The elderly people require assistance and supervision occasionally even in basic necessities. One of the most used services is the home health care, a group of professionals that built companies to give care to the ones who need it. The service includes personal care like feeding, bathing, among other things [3]. As a result of the world population ageing, there will be an increase for the demand of elderly people's care assistance, thus these services will be required in a bigger scale every year.

Eldercare is a responsibility of the family members and government. In countries such as Canada and the United States the adult children have legal responsibility to support their parents when they are not able to take care about themselves, thus the problem affects indirectly people of any age [4]. At the same time with the population ageing, more people require elderly care, i.e. more organizations are motivated to find ways to contribute with the assistance of older people.

Since the demand for personnel to take care of weaker people has increased, the mankind has tried to develop new technologies. The best example of this fact is the wheelchair, invented in China more than 1500 years ago, that helps to transfer people from one place to another [5]. This device has not changed only the life style of the users, the family and the society around them is directly affected. A person who is not able to use his legs to walk would be completely disconnected with the surrounding environment if he doesn't use a wheel chair.

The future seems nearer than ever, amphibious cars, jet packs, smart cellphones, 3D television, why not a robot helping elderly people with their basic necessities? That is the main idea of the "HOBBIT The mutual Care robot" project, financed by the European Commission. A common action as picking up objects from the floor, e.g., could become an impossible mission for older people. The HOBBIT project goal is to find a robot solution that decreases the risk of falling and improves the independence that allows older people to live at their homes longer [6].

On the other hand, fall related injuries have been a serious problem for people older than 65 years old all over the world. Approximately 30% of the older population falls every year at least once, which results in serious injuries and big costs [2]. The fall detection and prevention is the main task of the HOBBIT robot. The device should be able to detect any object at the floor that could lead to a fall accident and HOBBIT should call for help if an emergency is found. To take care of each other, the robot and the human have to build a relationship, and the HOBBIT project is focused on it, defining a mutual care concept.

One of the actions the most people perform many times during the day is standing up from a seated position; this motion is commonly called Sit-to-Stand movement. The process starts when the buttocks are in contact with any surface and the person wants to go to elsewhere or simply to reach a standing up position. This simple activity helps everyone to be independent, but for many people the movement could become a dangerous process if the person has not the required strength and balance for a proper performance.

It was reported that a 60% of people over 60 years have problems with the balance during the Sit-to-Stand movement, which implies a greater risk of recurrent falls [7]. For that reason many companies have been trying to find a workable way to make the raise up process easier and safer. There are different solutions that have been developed applying training and therapy, but also technology plays an important role developing different devices that help weaker people to do this movement independently.

Many companies like Handicare, EasyStand and Rifton have been working within this environment with the goal to offer a real solution to the Sit-to-Stand problem. They developed several designs that nowadays are part of the healthcare business.

The Sit-to-Stand devices allow the users to move from a sitting position at a bed, chairs, among others, to a standing position in a safer way. It should be design to give comfort and stability while the person is rising up. There are many alternative for the device, one common way is to give only a support for the upper body. In this case the user should be able apply some force. On the other hand, there are solutions that carry the whole mass of the person.

The benefits of the Sit-to-Stand devices include the independence that they give to the person. But the users are not the only ones with benefices. When someone is not able to rise up by himself, and there are no devices to support at the moment, there is need for a person to help. Very often the people who help in the Sit-to-Stand movement get injuries in several party of the body such as back and shoulders injuries [8].

1.2 PROBLEM DISCUSSION

The HOBBIT robot is able to detect and prevent dangerous situations, and one of the main risks is the fall related accident. Currently the device has many functions to avoid falls such as clearing the floor of unsafe objects.

The risk of falling down during the Sit-to-Stand movement is high; it is due to how hard is to balance the body before, during and after the motion, especially for people above 65 years. The HOBBIT robot is not capable to help the user when he needs to stand up, thus the device does not give any warranty to avoid a fall related accident while the movement is being performance.

The current problem is to design a rising support to help older people to perform the Sit-to-Stand movement for the HOBBIT robot, thus decreasing the balance problem present during the motion. But the solution to this problem brings the following question, is it possible to integrate this support to the robot and still find it stable? A wider robot base would make it impossible to

navigate in user's homes with lots of furniture and narrow door openings. This problematic is taken into consideration along the project.

1.3 JUSTIFICATION

The health care personal currently is being required in a wider magnitude than 50 years ago, thus technology is gaining importance to cover that demand. In the past it would be hard to believe how successful the business of developing equipment to help people who are not able to take care of themselves has become. But the economic success is not only what projects such as HOBBIT robot are looking for, also the aim of improving the independence and the quality of life of whoever needs it, brings huge motivation for a lot of people to work with developing projects related to rehabilitation engineering.

This project has positive impact firstly for the elderly persons allowing them to live independently and continue doing what they previous were able to do, and secondly for their families who do not have to worry so much if their parents or grandparents are able to satisfy their basic necessities.

Finally, a fall related injury could cause a strong impact in older people health, so by avoiding these accidents it is not only possible to allow to live in a safer way, it results in a significant costs reduction for families and governments too.

1.4 OBJECTIVES

General objective

Design a rising support to help older people to stand up. The device should be possible to integrate in the last model of the HOBBIT robot designed in a project financed by the European Commission.

1.5 RESTRICTIONS

The main restraint for this project comes with the dimensions of the latest version of the HOBBIT; its mass is estimated around 80Kg and the robot with the rising support integrated shouldn't overturn in any case while the user is performing the Sit-to-Stand movement. The user can exceed the device weight, so the structure should be stable enough to avoid any fall related accident.

The prototype will operate with elderly people in a house environment, thus any error could lead to a dangerous situation, because older users are prone to suffer harder injuries in any kind of accidents. So, a proper security factor has to be used during the design process, but it shouldn't generate additional costs, because the final price of the robot should be able to compete in the European market.

2 METHOD

This chapter is used to explain the methodology followed during the development of the project, including the design of one model and the studies to determine if it is feasible. In resume, the main idea was to develop a preliminary design, and then built a model similar to the resultant development for testing the behavior under the interaction with the users to determine the possible changes that the HOBBIT should present. On the other hand, the method followed to design the model is the one suggested by the professor Jose Miguel Torán from Simón Bolívar University in his course design methodology [9].

The project can be divided in three different processes, but each dependent on parallel progress in the other. The first step followed is the concept design, where a functional analysis is done in order to define the main characteristics of the desired prototype. Having defined the functionality, the generation of ideas starts with a brainstorming and brain writing in order to establish possible solutions, which should go through an evaluation process. This section of the project has to have as result a simple model that theoretically satisfies the main objective which is designing a rising support.

In order to determine if the model reaches all the objectives, studies should be done, and it is necessary to obtain experimental data to be able to predict the behavior of the structure using physical models based in Newton laws. Thus, the next big step of the project is the data collection that includes kinematical and dynamical studies, the first one using a motion capture system and finishing with displacement sensors with the purpose of getting the forces generated by the contact between the model, user and ground.

Having all the data collected, its analysis allows to verify if the main idea is adaptable to the HOBBIT robot. A model built in OpenSim together with the inverse kinematic tool permit to get the angles of the joints of the user body and the force application angles. On the other hand, with those results a physical model written in Matlab, after a period of iterations, gives the best dimensions to define a safe structure. Finally, as output of the muscoskeletal software, an animation is obtained and allows to preview the interaction of the user with the robot.

Finally, the prototype was tested with elderly people, measuring the forces and collecting qualitative data through surveys in order to validate the proposal.

In summary, the methodology is listed below:

- Literature review regarding the Sit-to-Stand movement
- Build a model of the Sit-to-Stand device based in preliminary studies
- Collect experimental data of the interaction between the model and the user with a motion capture system to determine the movement parameters using the inverse kinematic
- Built a skeletal model in OpenSim to study the motion and could be used as an example in the biomechanics course at LTH
- Estimate the forces generated in the Sit-to-Stand process between the mechanism and the human being using displacement sensors
- Develop a computational program using MATLAB based in Newton's laws to describe the behavior of the device under the forces produced by the interaction with the users
- Determine if the mass distribution of the last model of the HOBBIT robot should be changed to get an stable structure when the Sit-to-Stand support is integrated

3 THEORETICAL FRAMEWORK

This chapter gives the concepts and theories necessary to develop the master thesis.

3.1 THE HOBBIT PROJECT

HOBBIT is a research project proposed by the European Commission, it was created to develop a socially assistive robot to help seniors at home, and the goal of the HOBBIT project is to create a robotic solution that will improve the wellness and life quality for old people, enhancing their ability to live by themselves. The HOBBIT project develops the concept of mutual care; it builds a relationship between the human and the robot, meaning that both can help each other. The main tasks of the robot is to prevent accidents by picking objects in the floor, entertain the person, it can also help to stay socially connected and it is able to detect emergency situations. The robot provides autonomous navigation, a manipulator with a gripper and a user interface to allow interaction with the human. The HOBBIT project aims to offer many benefits to the user at a relatively low cost [6]. In Figure 4 the latest version of the HOBBIT could be seen.



Figure 4: Latest model of the HOBBIT robot [6]

3.2 THE SIT-TO-STAND MOVEMENT AND PRODUCTS

The Sit-to-Stand (StS) movement helps the people to stand up when they are sitting down; it means this process allows us to live the life as we know. One of the most common ways to describe the motion is dividing the process in four phases. The first one begins with the initiation of the movement and ends just before the buttocks are lifted from the seat of the chair (flexion-momentum phase). The second phase or momentum transfer phase starts when the buttocks are in the air and finishes when ankle dorsiflexion is achieved. It is followed for the extension phase (number three), starting with the ankle dorsiflexion and finishing when the hips stop extending. The last phase is the stabilization (number four) that ends when the body is completely stable. This process was mainly described by Schenkman et al [10].

The following picture (Figure 5) shows how the movement is being performed; the Sit-to-Stand movement includes any attempt to stand up from any object such as chair, bed, wheelchair, bench among others.



Figure 5: Sit-to-Stand movement

3.2.1 Determinants review

There are many determinants that define the movement; the most important include the seat height, armrests, chair type and strategy-related determinants.

The determinants related with the strategy depend in every person. As an example there is the speed that increases the hip flexion, knee and ankle joint moments. The foot positioning plays an important role in the StS movement as well; it is known that placing your feet closer to the center of mass (Posterior position) is possible to reduce the maximum hip extension moment at least four times. It means that using the right technique to stand up is possible to reduce the strength required for the movement in a considerable amount [11].

In order to give an overview of the determinants of the sit to stand movement, the following table shows the most important ones with a short description.

Table 1: Determinants of the Sit-to-Stand movement [11]

Determinant	Comment
Seat Height	Lowering the seat height makes harder the movement
Armrests	Including the armrests during the movements reduces the moments at knees and hip
Speed	Increasing speed of the motion increases the hip flexion
Foot Positioning	Posterior position allows to reduce the maximum hip extension moment at least four times
Trunk Positioning	With maximum flexion of the trunk the knee joint moments could be reduced by 27% compared with an erect position of the trunk at the beginning of the movement
Arm Movement	The arm movement changes considerable the center of mass of the body during the whole motion
Knee Positioning	Positioning the knee in more extension could increase the hip extension moments up to 77% more than using a foot-backward setup

3.2.2 Movement techniques and assistance

When a person can manage the strength and balance required for the Sit-to-Stand movement, it is possible to perform it without any problem, but there are some recommendations that allow the people to stand up in a safer way. In order to complete a successful movement the following steps should be followed, firstly use any firm surface as support for arms such as armrests or the edge of a bed (To find stability during the action), secondly place the feet back (under the seat if it is possible), then move forward the trunk with the purpose of getting the nose above the toes (The buttocks should be placed in the edge of the seat). To finish the process creating a moment it is necessary to lift the body (Never lose contact with the hand support if it is needed). Finally balance the body to get a proper standing position [12].

The following picture (Figure 6) shows a person just before the moment when the moment should be created in order to reach the standing up position.



Figure 6: The beginning of the second phase of the Sit-to-Stand movement [12]

On the other hand, there are people who are not able to manage the Sit-to-Stand movement by themselves, so it is necessary to have an external help to reach the goal (To stand

up). For this problem it is possible to find a trained staff to help the person but there are mechanical devices to support the movement as well.

In the case of having a prepared personal to help, the process that should be followed is the next one. Following the same steps described above, but in this case the additional carer should, first stand beside the seat and face the same direction as the person, then bend the hips and knees delicately. After that, the helper should place one hand at the shoulder and the other one at the lower back of the person that he or she is taking care (In Figure 7) is possible to see the right position of the hands). Finally stay close to the person while the transfer is being performed using the hands to give the strength and balance required.



Figure 7: The beginning of the second phase of the Sit-to-Stand movement with a carer [12]

3.2.3 Developed products

Different companies have seen the health care business as an opportunity to develop an economic and social project. A good example of this is Handicare, its founders were focused in developing alternatives to give independence to the disabled and elderly people who were not able to take care about themselves.

Finding a solution for people that are not able to stand up without an external help have been the main task for corporations such as EasyStand or EZ way. Different answers have been developed for this problem, including from only supports just for hand or legs up to lifts for the whole mass of the users. It is presented below several products that were built to help people to stand up.

3.2.3.1 Vancare Vera II B450

This transfer device, operated by batteries, was designed with the purpose of reducing back injuries in the nursing staff which could be affected; it is possible due to de capacity of the lift to rise up persons weighing up to 204Kg. The main task for the Vera II B450 is to allow the user to reach a standing position and hold it while is being transfer to a bed, chair or wheelchair. An image of the prototype can be appreciated in the following picture (Figure 8) [13].



Figure 8: Latest model of the 2.1.2.1 Vancare Vera II [13]

It is important to know that this device is built to help people who are not able to apply any moment in hips, knees or force with their arms, thus a third person is required to operate the Vera II while the persons is being transferred. The principle used for the mechanism is to apply a

lift force in the back of the user, at the same time there is a support for both knees in order to balance the human body during the whole process. And the structure has to be stable, i.e. the dimensions of the device (when its arms and legs are closed) are relatively big (length 1m and width 0.6m), this characteristic makes the Vera II hard to move, either inside or outside a room.

3.2.3.2 Handicare ReTurn7100

The company Handicare has developed the ReTurn7100 concept, which is a simple design with supports for hands and knees, and a base for the user's feet for facilitating the transfer of him or her. As the Vera II this device allows weaker people perform a safer and active Sit-to-Stand movement and transfer to or from wheelchair, bed or chair. The mechanism can be used as rehabilitation device as well.



Figure 9: Latest model of the Handicare ReTurn7100 [14]

In order to reach a standing position with the ReTurn7100, the user has to pull with the arms to lift the body, and the knee support offers stability to the person. It is important to say that this device was not designed for people who are not able to use their own muscle force to

complete the movement, because the user has to have at least the power enough to rise up with the help of the supports, but this functionality gives to the prototype a better maneuverability and easier transportation. It is because the mechanisms don't need to have an engine to complete the process (The energy required is only from the users). In the picture above (Figure 9) the ReTurn7100 product is shown [14].

3.2.3.3 Handicare QuickMove

SystemRoMedic™ is the line of Handicare dedicated to find solutions for the people transfer problem, in this section they have designed the QuickMove (Figure 10) that helps the person to stand up and move him or her to another place. This device, unlike the others above mentioned, forces the users to move forward their center of mass in order to reduce the strength required for the Sit-to-Stand movement. This prototype is aimed at people that are able to use their muscles but don't have the balance and strength required to complete a safe standing up movement.



Figure 10: Latest model of the Handicare QuickMove [15]

3.2.3.4 Robot Suit HAL

There are simple and more complicated solutions for the people transfer problematic, but clearly the robot Suit HAL is one of the most daring projects in this field. It consists of an exoskeleton that improves the strength and balance of the whole body of the user, allowing people with disabilities to transfer independently as an able-bodied person.

Atsushi Tsukahara et al demonstrated in their study “Sit-to-Stand and Stand-to-Sit Transfer Support for Complete Paraplegic Patients with robot Suit HAL” how this device is able to make the desired movement in a safer way, improving the quality of life of the users. The intention with the robot is to give back the physical requirements demanded for the standing up movement. In Figure 11 it can be appreciated how the device allows the person to perform movements that require a higher strength than the one her body can afford [16].



Figure 11: Last model of robot Suit HAL [16]

3.3 MOTION CAPTURE SYSTEM

The process of getting experimental information of any movement in objects, animals or humans and previewing that data in a digital device is called motion capture (Mocap), that is used with several objectives such as creating computer animations, or with medical or mechanical reasons [17].

There are several motion capture methods. Often the most used is having multiples cameras to record a certain group of reflective “markers” (Points of interest to study in the body) usually placed in joints [18]. The set-up allows saving the placement coordinates of those markers regarding to a predefined coordinate system in a text file. This information can be interpreted, previewed and analyzed by different software such as Fastmocap, ARENA, Expression and Tracking Tools among others for animation, and OpenSim or AnyBody for biomechanical reasons.

In the following image (Figure 12) a common motion capture system set-up is shown.



Figure 12: A common motion capture system set-up [18]

3.4 OPENSIM

OpenSim is a free software system that allows the users build models of musculoskeletal structures and generate dynamic simulations of movement. The program is written in ANSI C++ and Java is used to develop the graphical interface. OpenSim lets the users to model, simulate, control and analyze the neuromusculoskeletal system. The models include the most of the muscles and bones of the body and it is possible to describe three-dimensional movements [19].

OpenSim models are written with a XML language, which means that to be edited the user should get used to working with software such as NotePad++ or XMLMarker (XML files editors). This method of changing the model set up can be confusing and even hard to learn. For this reason it is recommended to devote enough time in practicing the model editing process before stating to work with OpenSim. The main advantage of using this programming language is that it makes the user free to change everything he or she wants to change.

Once the user get used to working with files .osim and .xml, is ready to start analyzing the human body with this software, that allows previewing data provided by the motion capture system described above. OpenSim lets to make coincident the experimental markers gotten in the laboratory with the virtual markers (Defined in the .osim file) in order to drive the model and generate the desired motion.

The OpenSim's interface is user friendly and offers several tools to analyze all kind of simulation. In Figure 13 a screenshot of the user interface and the tools integrated to the software is shown. Scale model, Inverse Kinematics and Inverse Dynamics tools allow the user to makes a complete mechanical study of the human body.

For this project the main tools are scale model and inverse Kinematics, the first one has two ways to operate, one introducing values coming from a manual measurement process of the human body, or OpenSim is able to recognize automatically the distances between the experimental markers (With this information is possible to scale the model as well). Secondly the inverse Kinematics lets you determine the different solutions for the positions of the body's parts during the whole simulation. This tool allows getting information of any angle between the joints and body sections in the motion process.

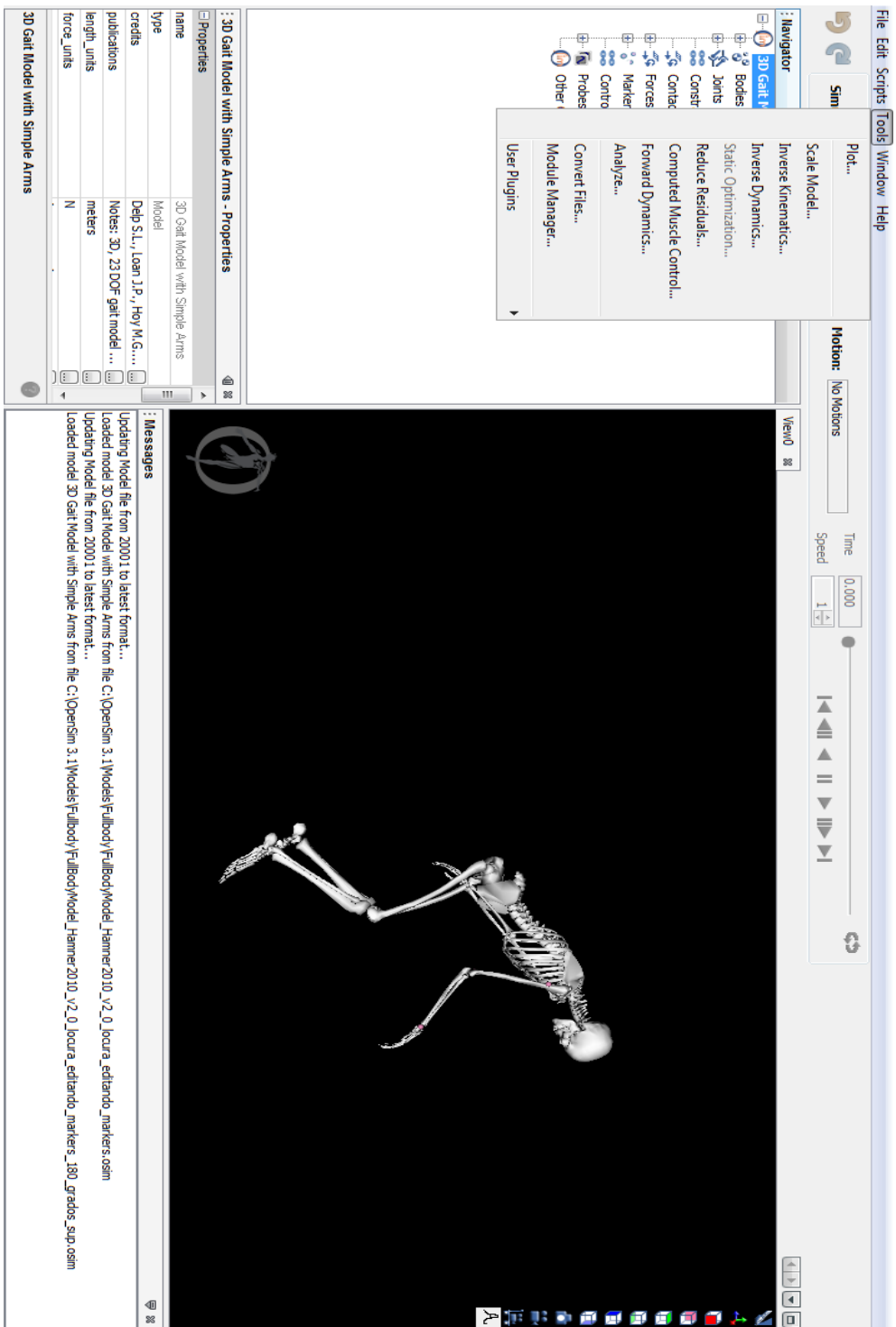

Figure 13: Screenshot of the interface of OpenSim showing several tools [19]

4 CONCEPT DESIGN

The first step of the design is to define the technical specifications of the desired model, in order to determine the main necessities the device should cover.

4.1 NECESSITY

As described above the main necessity is to find a solution for a rising support to help elderly people to stand up, reducing at the same time the risk of any fall related injury. The prototype result of this design project should be integrated to the HOBBIT robot.

As it could be appreciated in the theoretical framework, after the literature research, the best way to help people to stand up is by forcing the user to move the upper body forward in order to place the mass center of the whole body closer to the feet and they should be placed as far back as possible (even under the chair), and all this in order to reduce the moment required to complete the movement. On the other hand, the person needs to maintain the balance to avoid a fall related accident. To reduce the risk of falling, the user needs supports if it is possible for his or her knees, arms (As it could be appreciate in all developed products in theoretical framework) and shoulders (following the instructive of ACC [12])

4.2 FUNCTIONAL ANALYSIS

This section is focused on identifying the different functions the model should perform; this is made with the purpose of dividing the main problem in smaller ones in order to facilitate the design process. The methodology used for this section starts firstly with a black box diagram to define the inputs and outputs of the process, secondly a diagram of functions which splits the tasks, and finally a process diagram to determine the steps the final design should follow with the aim of reaching the main objective.

4.2.1 The black box

This tool is used to describe and identify the interaction of the device with the environment (Inputs and outputs of the process) in order to help to define the main functions the prototype should include. Figure 14 shows the black box diagram.



Figure 14: Black Box diagram to define inputs and outputs of the process the device should complete

4.2.2 Diagram of functions

In the following diagram (Figure 15) it is possible to find the different functions the dispositive should perform in order to reach the objective.

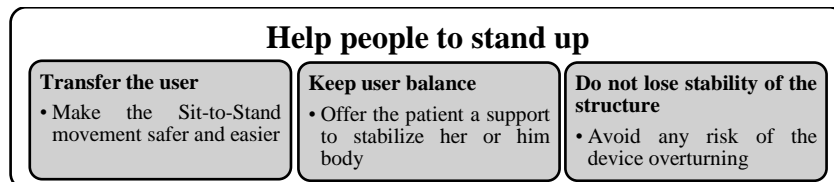

Figure 15: Diagram of functions

4.2.3 Process Diagram

In Figure 16 the suggested process that the model should follow to finish a safer and easier Sit-to-Stand movement is described.

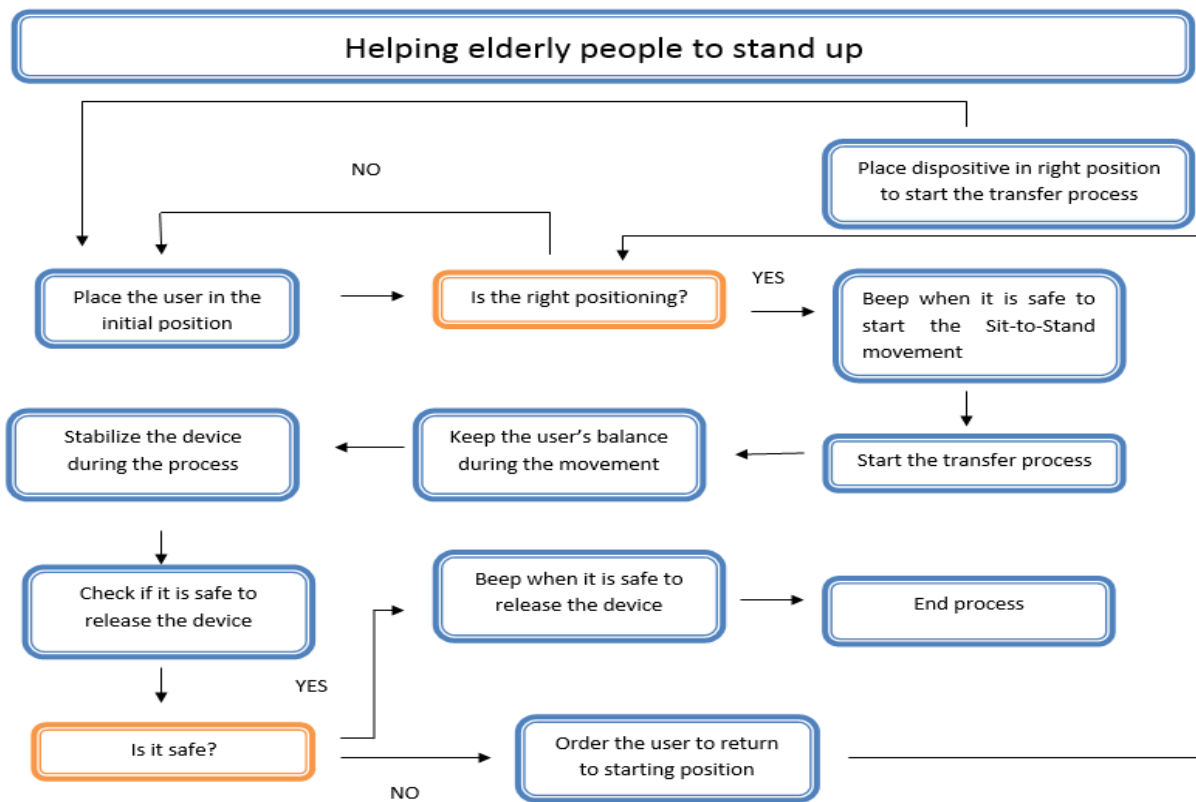

Figure 16: Diagram of the process required to reach a standing up position

4.3 TECHNICAL SPECIFICATIONS

In this section the specifications that should be followed during the design are listed.

4.3.1 Functional characteristics

- It could work with or without electricity
- It should support the forces generated in the interactions with humans
- It has to allow the user to perform an easier and safer Sit-to-Stand movement
- The stability of the device is the main risk factor to consider
- The device should offer supports of arms, knees or back/shoulders

4.3.2 Environmental conditions

- The device will work in an indoor home environment
- It should be completely wireless
- It has to be able to adapt between chairs, bed or any furniture
- To avoid any obstacle such as carpets or objects in the floor should not be a major problem

4.3.3 User characteristics

- The design is mainly intended to deal with elderly people
- The user may have physical disabilities

4.3.4 Interface

- The device will be integrated to the HOBBIT robot, being this task the main objective of the project

4.4 GENERATION OF IDEAS

For the process of generation of ideas the brain storming and brain writing techniques were applied with the purpose of getting a design that satisfies the objectives. The following figures show the best two alternatives after a long design process. Firstly, the designs were not fully defined, in this sections only basic sketches were presented without deep details.

4.4.1 First option



Figure 17: Option 1

This design was the first idea for this project. It is based in studies of many products already designed. It consists in three different supports, the first one for fixing both legs with the purpose to stabilize the lower body, while the other two are handles which the user is able to pull, thus the moment required in the hip and knees would decrease considerably. This model does not work with a natural movement of the human body, it is due to the patient's restriction in arms and

legs, consequently this idea would require an exhaustive analysis in order to study the feasibility to apply it in the HOBBIT robot. A picture of the first option is shown above (Figure 17).

4.4.2 Second option

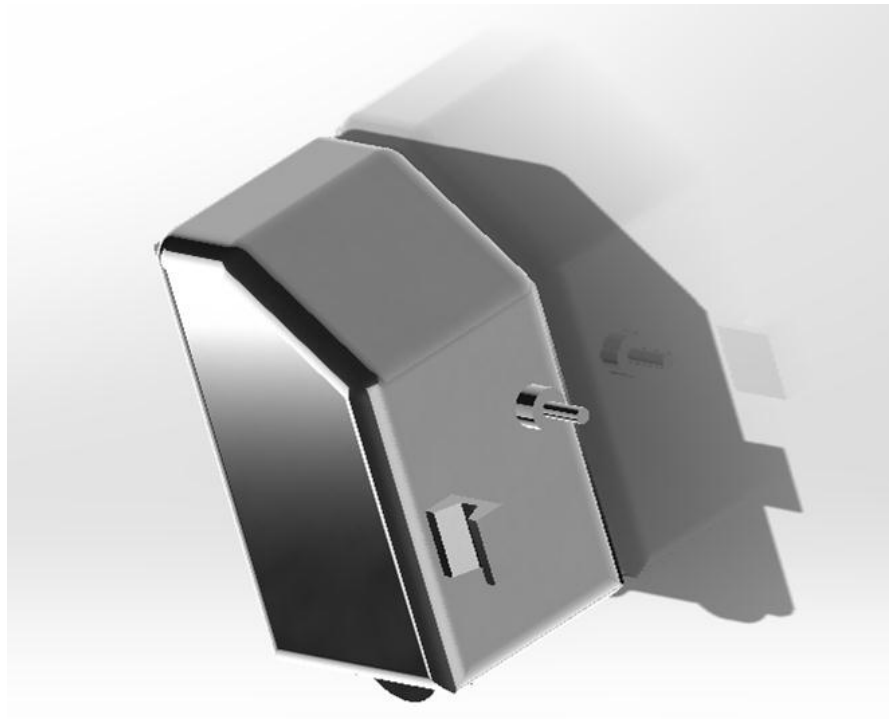

Figure 18: Option 2

The design shown above (Figure 18) is simpler and works with a natural movement of the body, the user places one leg in the lower support, which gives balance to the lower part of the body. The aim of the upper support is to drive the user to the right position to start the Sit-to-Stand movement (upper body placed forward with the nose just above feet), at the same time the person can pull or push it in order to reduce the strength required by leg muscles, and improve the

balance. In order to reduce the torque in hips the user should be placed in the edge of the seat (explained in theoretical framework, in movement techniques section).

On the other hand, this model follows Germund’s design, the difference appears in the lower support, which in this case should be able to tilt and move vertically in order to allow the user to have his or her knee in contact with it and place his or her feet further back.

Finally, it is necessary to decide the side where the supports should be placed (front or lateral side of the robot), this is studied in the following chapters of the project.

4.5 EVALUATING PROCESS

The models presented above were only ideal designs, the following step required to decide the best option to move forward. In order to help with the decision a matrix was made assigning values to different parameters, the result is shown below in Table 2.

Table 2: Decision matrix

Criterion (100Pts)	Option 1	Option 2
Technical feasibility (Yes or No)	Yes	Yes
Reaches the objective (30pts)	30	20
Manufacturing feasibility (10pts)	5	8
Maintainability (10pts)	5	8
Usability (20pts)	20	15
Integrable to HOBBIT (30pts)	15	30
Total	75	81

In Table 2 the best options is the number 2, because the design is simpler and theoretically should reach the objective. This idea needs to be tested in order to define all its physical parameters. The option 2 will be used as a base for the following steps to reach the final design.

The preliminary positions used for the supports in the prototype are the suggested by Germund Larsson in the previous master thesis for an older version of the HOBBIT robot [20].

His proposal does not suggest a tilt angle for the knee support but the dimensions of it will work for the first studies of this new prototype. The positions of the supports are shown in Figure 19.

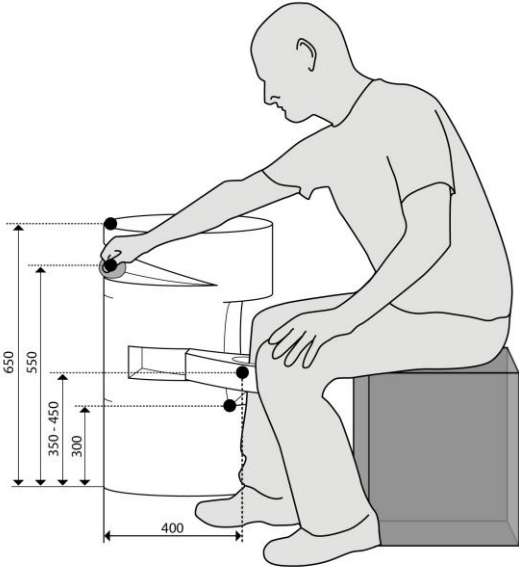

Figure 19: Germund Larsson's proposal for the distances of the supports [20]

5 DATA COLLECTION

This chapter describes the method followed to collect the information required for the analysis that allows reaching proper conclusions regarding the design. It is possible to split the data collection in three parts, the laboratory set-up manufacturing, the forces measurement and the motion capture system. For this process people of different ages were used in order to compare the different results.

5.1 LABORATORY SET-UP

The main goal of the project is to design a rising support. In the last chapter a preliminary model was defined. In order to move forward it is necessary to develop a mechanical analysis that determines the dimensions and the feasibility of the design. Any physical model should be as similar to the reality as possible. For that reason with the purpose of studying the dynamical and kinematical behavior of the possible solution, a model was built including displacement and movement sensors to get useful information.

The alternative chosen consists in two supports, one for the knee and one handle, thus the model built should include both. A wooden box (made in a previous thesis work by Germund Larsson) was used. It has two supports and allows changing the position of them. Additionally sensors to estimate the load were added. The result can be appreciated in the following picture (Figure 20).



Figure 20: Measurement prototype

5.2 FORCE MEASUREMENT

This section implied one of the hardest parts of the project, because adding loads sensors to the supports required to design a smart solution to estimate real values of the force for the whole interaction between the user and the model.

The first step was to define the kind of sensors that were going to be added. After a research process, the displacement sensors were chosen to be integrated to the model. LTH provided an older prototype that included this kind of measuring device (Figure 21).



Figure 21: Older device with the measuring sensors included

In Figure 21 the displacement sensors could be observed. They are the small rings placed between the black seat and the aluminum bars.

Having the sensors the problem was to estimate the load, thus a short model was done to demonstrate the relation between displacement and load for this case. In Figure 22 a free body diagram (DCL) of the ring to help with the understanding regarding the measuring device is shown.

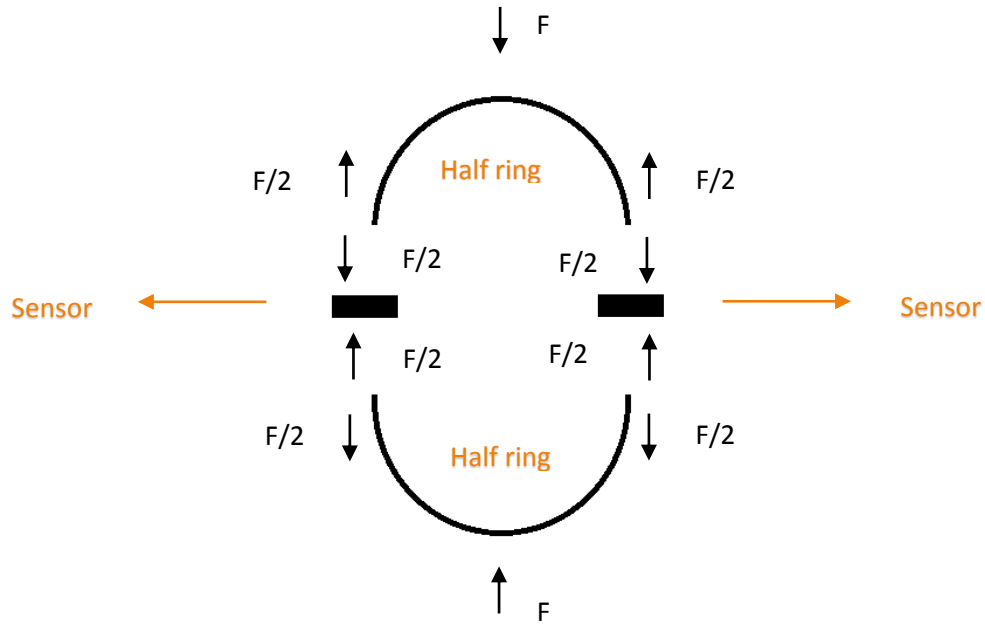

Figure 22: Displacement sensors model

The sensors output is a displacement, i.e. the force should be estimated. Applying Hook's law is possible to calculate the loads (equation 1), but a preliminary calculations should be done in order to calibrate the system. On the other hand, it is necessary to mention that Labview software was used to get the outputs coming from the sensors.

$$F = K \cdot \Delta x \quad (1)$$

Where:

- F: Force applied to the sensor
- K: Linear coefficient
- Δx : Displacement difference

Equation 1 shows the linear behavior of the force regarding the displacement; this theory was used to calculate the forces. The values of the “K” coefficient were obtained and are reflected in Table 3. In order to get those values, every sensor was tested with different known loads, then with the data. A linear estimation was made and the curve fitting resulted almost perfect with a value of R^2 equal to 0.99 for each measuring device.

Table 3: K values for displacement sensors

Ring	K (Kg/Volts)
Green and Yellow	3.45E5
Green	3.90E5
Yellow	3.76E5

In Table 3 the unit for the K coefficient is Kg/Volts, it is due to the output coming from the Labview software is a voltage spike that is proportional to the displacement. How the desired parameter is force, the calibration was done directly with loads values. It is possible assuming the forces applied are below the yield strength of the sensor’s material (aluminum).

After some tests the data was diffused, thus it was necessary to apply a virtual filter in order to get interpretable information. For the filtering process the command “butter” was used in Matlab software. In Figure 23 it is possible to observe how the noise decreases in a signal that should be flat (should have the same value along the time), the blue curve represents the data before using the virtual filer and the red line after.

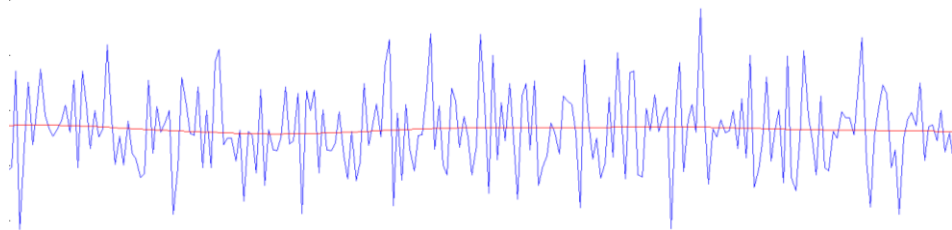

Figure 23: Noise reduction in the sensor's output

Note: The sensor reports positive values for compression and negative values for tension.

Having defined the method to get the force values with the displacement sensors, the problem was how to add it to the supports in order to find the best results. In Figure 24 a CAD model of the solution for the handle is shown.

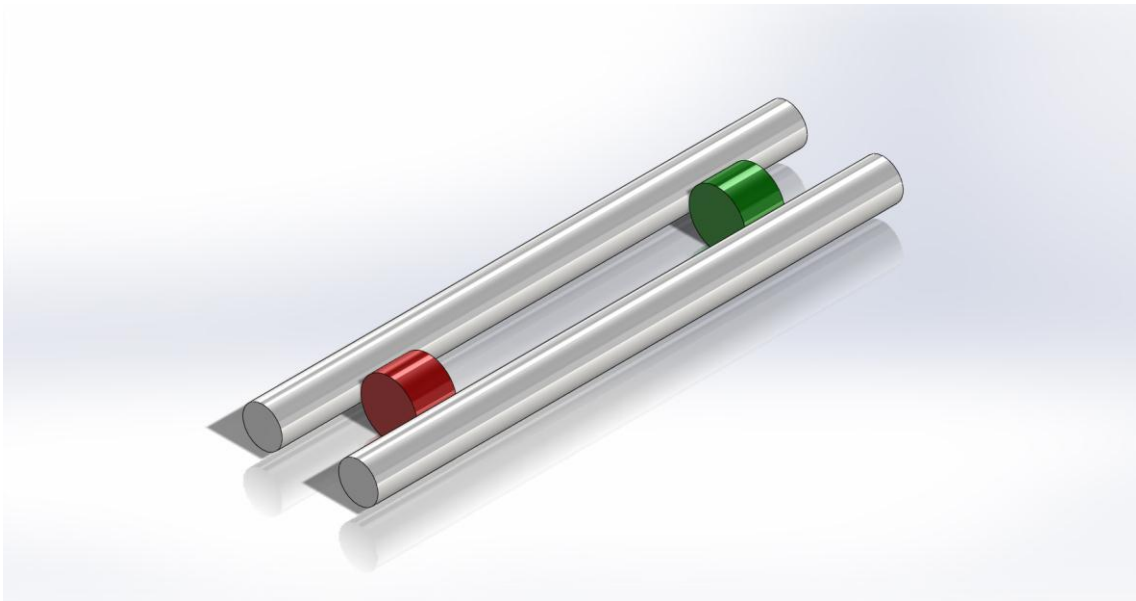

Figure 24: Handle with sensors integrated

This distribution was decided because the sensors can only measure the displacement in only one direction. Thus if only one bar is attached to the model, but can turn around its axis, all the force applied in the other bar (handle) is in the direction the sensors can measure. Figure 25 helps to explain it. It is true that the results could be affected because of degree of freedom (the handle can turn) but is a better approximation than fixing the support and getting only one component of the total force. In Figure 20 it is possible to appreciate the handle already manufactured and integrated to the model.

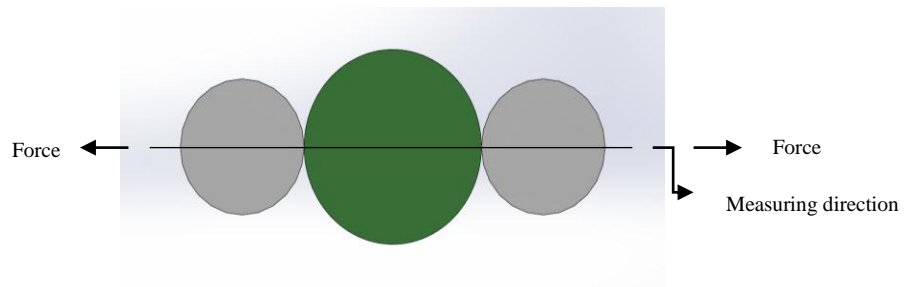

Figure 25: Measuring direction

The solution for the knee support was much simpler, because the force was normal to the contact with the user's leg and the tilt angle is fixed during the movement. In Figure 26 it is possible to observe the result.

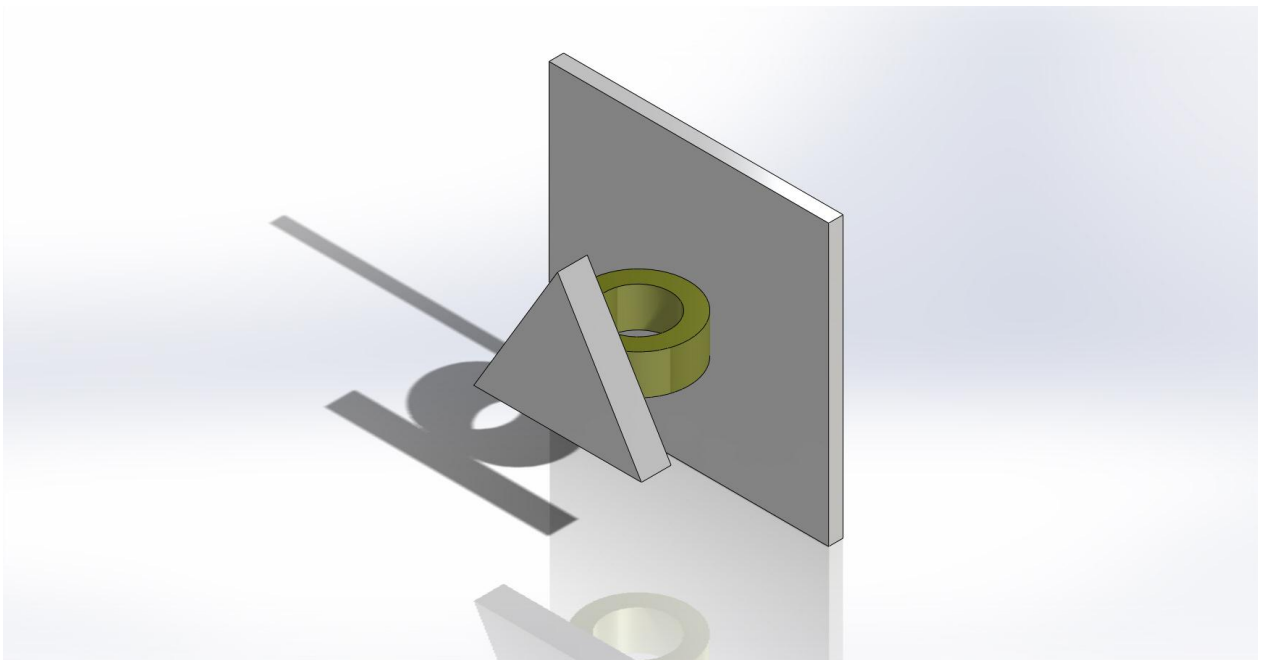

Figure 26: Knee support (the knee pushes on the flat surface of the triangular part, which needs to be modified for the final product)

5.3 MOTION CAPTURE SYSTEM

With the objective of recording the movement information the K600 Nikon Metrology motion capture system (Figure 27) was used in the robot laboratory at LTH. In Figure 28 the marker distribution is shown. The data was interpreted in the OpenSim software and the analysis is described in the following chapter.



Figure 27: Motion capture system

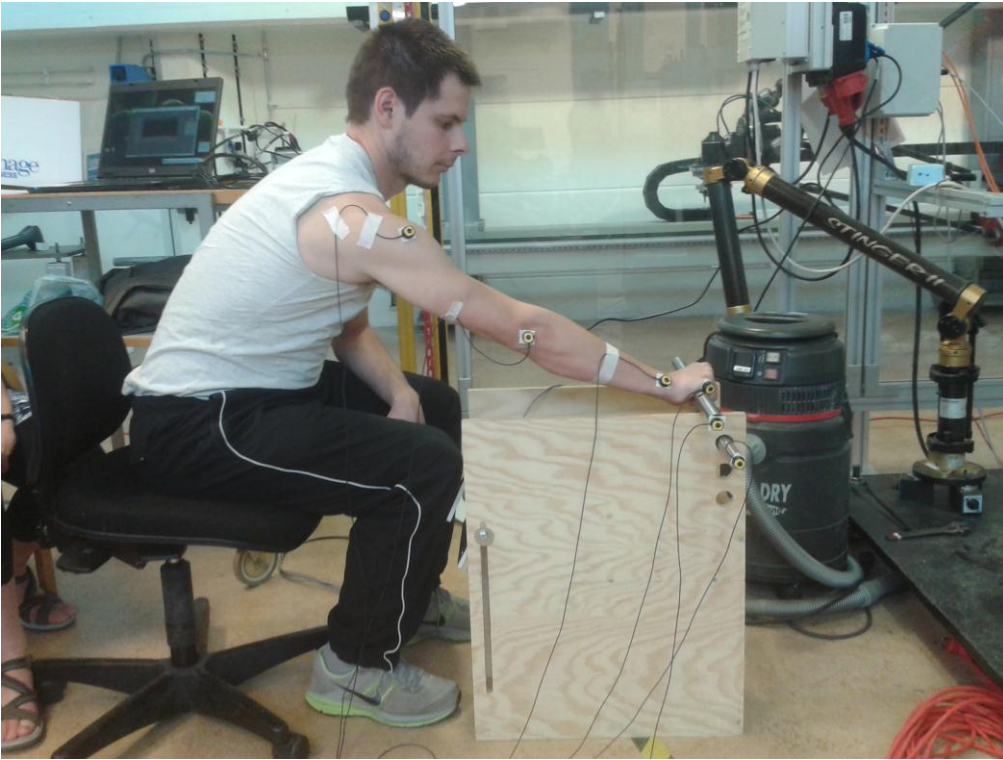

Figure 28: Laboratory set-up

5.4 SURVEYS

For every person who tried the model, 5 males and 2 females between 21 and 90 years, several questions were asked to get a feedback and evaluate the feasibility of the project. Not for all the cases a defined survey was used, instead a little talk was established in order to define the user perception. The following questions were used as a base for most of the tests.

- Do you think it is necessary to have support to avoid the risk of falling when you are standing up? (Answer with Yes, No and comments)
- If you have a support such as the model you used before, would you use it frequently? (Answer with Yes, No and comments)

- Do you think the device helps you to stand up? (Answer with Yes, No and comments)

- Was it comfortable to use the handle for pulling? (Answer with Yes, No and comments)

- Was it comfortable to use the handle for pushing? (Answer with Yes, No and comments)

- General comments (Such as general opinion or what would you change)

5.5 DATA COLLECTION PROTOCOL

Having all the procedure defined, the measurement process started. In Figure 28 the laboratory set-up is shown. For every laboratory session the methodology followed was as similar as possible. It started by attaching the markers to the user's body and positioning the motion capture system facing a lateral of the wooden model. Then, the Sit-to-Stand movement had to start at the same time as the motion data and forces recording. Finally a short talk regarding the opinion of the volunteer was established. In several cases a quick survey was applied.

6 MODELS AND VALIDATION PROCESS

6.1 OPENSIM MODEL

In order to study the kinematic of the tests, a skeletal model of the users arm was built in OpenSim software. In this section of the thesis a description of how the model was created will be given with the purpose of facilitating the understanding for the model editing with this computer program. This explanation should facilitate a more complicated model creation for future researches in this field.

6.1.1 Importing the motion data

The output coming from the motion capture system is a Matlab file that has to be imported into an OpenSim file (.trc). This file consists of a special distribution of the data in a text file, which is easy to edit using the Microsoft Excel editor. Figure 29 shows an example of the format required, where it is necessary to define the marker name, camera recording frequency, numbers of frames, units and coordinate values.

1	PathFileTy	4	(X/Y/Z)	C:\Documents and Settings\user\My Documents\MotionFiles\BioEngCompLab_Data\Delaware\Subject 2\running_3001_smoothed.trc														
2	DataRate	CameraRa	NumFram	NumMark	Units	OrigDataR	OrigDataS	OrigNumFrames										
3	100	100	253	5	mm	60	1	253										
4	Frame#	Time	wrist_marker			r_humerus_epicondyle			upper_humerus			upper_handle			pivot_point			
5			X1	Y1	Z1	X2	Y2	Z2	X3	Y3	Z3	X4	Y4	Z4	X5	Y5	Z5	
7	1	0.01	-205.366	-404.022	-44.6517	-158.87	-185.989	89.61033	30	0	30	-267.663	-446.257	100.0666	-325.263	-490.601	108.4267	
8	2	0.02	-204.926	-404.242	-44.3103	-158.358	-186.812	91.04015	31.15125	-1.7808	29.81493	-267.425	-446.371	100.272	-325.048	-490.663	108.677	
9	3	0.03	-204.647	-404.378	-44.1377	-157.688	-187.678	92.38905	32.40892	-3.58468	29.62355	-267.218	-446.457	100.4801	-324.816	-490.81	108.7729	
10	4	0.04	-204.603	-404.427	-44.0539	-156.865	-188.591	93.62028	33.7728	-5.40804	29.43881	-267.117	-446.473	100.5759	-324.602	-490.947	108.9584	
11	5	0.05	-204.772	-404.433	-44.0995	-155.929	-189.536	94.72387	35.24448	-7.25313	29.26946	-267.168	-446.36	100.5166	-324.48	-491.044	108.9444	
12	6	0.06	-205.044	-404.4	-44.2541	-155.026	-190.461	95.62618	36.79791	-9.12984	29.09726	-267.252	-446.122	100.4312	-324.364	-491.058	108.8879	
13	7	0.07	-205.285	-404.38	-44.422	-154.249	-191.321	96.36324	38.40656	-11.0661	28.85945	-267.317	-445.84	100.2401	-324.224	-490.999	108.8356	
14	8	0.08	-205.429	-404.423	-44.6265	-153.621	-192.098	96.92226	40.04649	-13.083	28.54669	-267.26	-445.624	100.017	-323.997	-490.968	108.765	
15	9	0.09	-205.519	-404.531	-44.9301	-153.091	-192.805	97.24039	41.74576	-15.1827	28.20568	-267.07	-445.462	99.84347	-323.681	-490.952	108.7016	
16	10	0.1	-205.623	-404.682	-45.3322	-152.564	-193.439	97.28704	43.55973	-17.3142	27.72537	-266.866	-445.304	99.6166	-323.357	-490.906	108.6239	

Figure 29: .trc file editing

Having the .trc file fully defined, OpenSim allows to preview the data, the following picture (Figure 30) is a screenshot of the preview mode. It is possible to visualize the position of the markers in the space.

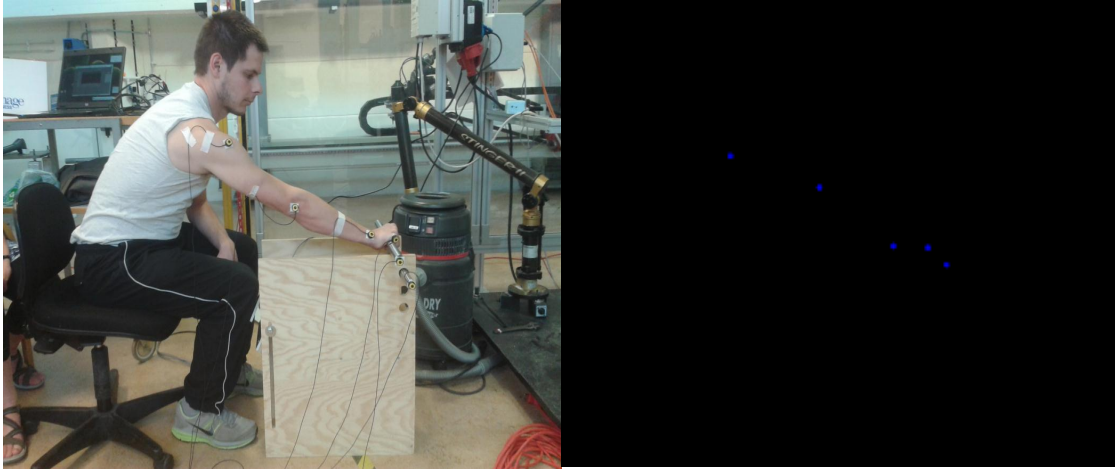

Figure 30: The markers distribution at the laboratory is shown to the left and the markers OpenSim preview to the right

6.1.2 Creating the model

Creating an OpenSim model could result confusing, because it does not have a user friendly interface, the user has to create a XML file defining all the characteristics of it. A model file should be called .osim at the end of the name. In Figure 31 the structure of a model file in OpenSim could be seen.

```

2 <OpenSimDocument Version="20303">
3 <Model name="arm26">
4 <!--See the credits section below for information about this model's authors, data sources, intended uses, and more. See the publications
5
6 <credits>
7
8 <publications> Holzbaur, K.R.S., Murray, W.M., Delp, S.L. A Model of the Upper Extremity for Simulating Musculoskeletal Surgery and Analyzing Neuromuscular Control.
9
10 <length_units>Meters</length_units>
11 <force_units>N</force_units>
12 <!--Acceleration due to gravity.-->
13 <gravity> 0 -9.8066 0</gravity>
14 <!--Bodies in the model.-->
15 <BodySet>
16 <object>
17 <Body name="ground">
18
19 <Body name="r_humerus">
20
21 <Body name="r_ulna radius hand">
22
23 </object>
24 </groups />
25 </BodySet>
26 <!--Constraints in the model.-->
27 <ConstraintSet>
28
29 <!--Forces in the model.-->
30 <ForceSet>
31
32 <!--Markers in the model.-->
33 <MarkerSet>
34 <object>
35 <Marker name="r_acromion">
36
37 <Marker name="r_humerus epicondyle">
38
39 <Marker name="r_radius styloid">
40
41 </object>
42 </groups />
43 </MarkerSet>
44 <!--ContactGeometries in the model.-->
45 <ContactGeometrySet>
46
47 <!--Controllers in the model.-->
48 <ControllerSet name="Controllers">
49
50 <!--Probes in the model.-->
51 <ProbeSet>
52
53 <!--Additional components in the model.-->
54 <ComponentSet name="MiscComponents">
55
56 </Model>
57 </OpenSimDocument>

```

Figure 31: View of the editing process of an OpenSim model

For this project the only sections used were the “BodySet” and “MarkerSet”, where all the geometry of the model and the position of the markers were defined.

6.1.3 Scaling and inverse Kinematic tools

For this project the scaling tool was used in the automatic mode. OpenSim recognizes the markers and adjusts the distances in order to reduce the error between the real and the virtual markers as much as possible. As the model editing it should be defined in an XML file, this tool needs the .trc as input file and the model with the virtual markers included.

On the other hand, the kinematic tool requires to define a third XML file which should define the relation between the .trc and the virtual markers. As an output a .mot file is obtained. It drives the created model and an animation could be seen in the main screen, and it is possible to plot the information of the angles/positions of the joint/bodies along the time.

6.2 STABILITY MODEL AND SPATIAL DISTRIBUTION

After defining the kinematic parameter, a static analysis was developed to study the balance of the HOBBIT. The model below (Figure 32) is based in the Newton equations to describe the behavior of the robot structure under the loads applied by the humans when they are interacting with the device.

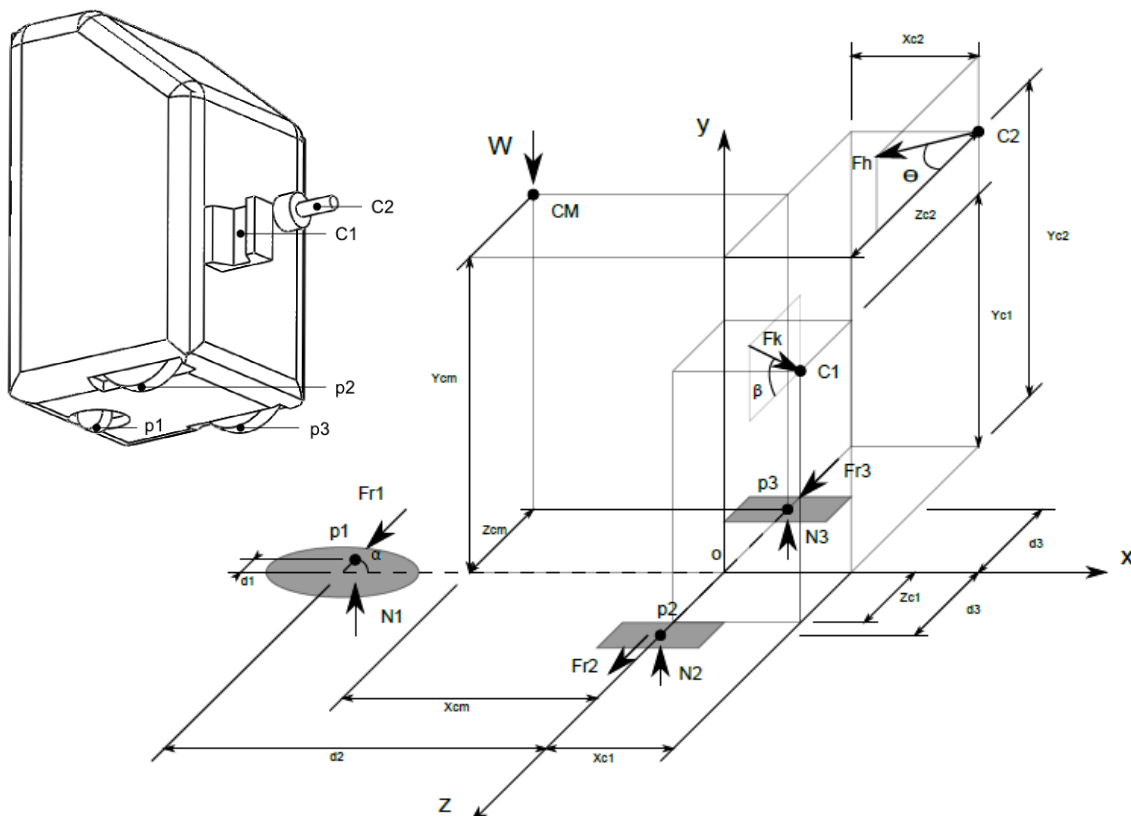

Figure 32: Physical model to study the balance of the HOBBIT

Note: The meanings of the variables are defined in the nomenclature section at the beginning of this thesis.

Newton's equations:

$$\sum F_y = -W + F_h \cdot \sin(\theta) - F_k \cdot \sin(\beta) + N_1 + N_2 + N_3 = 0 \quad (2)$$

$$\sum F_z = -F_k \cdot \cos(\beta) + F_h \cdot \cos(\theta) + F_{r1} + F_{r2} + F_{r3} = 0 \quad (3)$$

$$\sum M_{ox} = d_3 \cdot N_3 - d_3 \cdot N_2 - Y_{C1} \cdot F_k \cdot \cos(\beta) + Y_{C2} \cdot F_h \cdot \cos(\theta) + Z_{C2} \cdot F_h \cdot \sin(\theta) - Z_{cm} \cdot W + Z_{C1} \cdot F_k \cdot \sin(\beta) = 0 \quad (4)$$

$$\sum M_{oy} = (d_2 - d_1 \cdot \cos(\alpha)) \cdot F_{r1} + X_{C1} \cdot F_k \cdot \cos(\beta) - X_{C2} \cdot F_h \cdot \cos(\theta) = 0 \quad (5)$$

$$\sum M_{oz} = X_{C2} \cdot F_h \cdot \sin(\theta) + X_{cm} \cdot W - (d_2 - d_1 \cdot \cos(\alpha)) \cdot N_1 - X_{C1} \cdot F_k \cdot \sin(\beta) = 0 \quad (6)$$

The objective is to determine if the center of mass is placed in the right position to find the robot stable. If it is not, it is necessary to find the coordinates (X_{cm}, Y_{cm}, Z_{cm}) that allow the structure to be in balance even when the forces are maximal.

In Figure 33 the position of the contact points with the ground are defined.

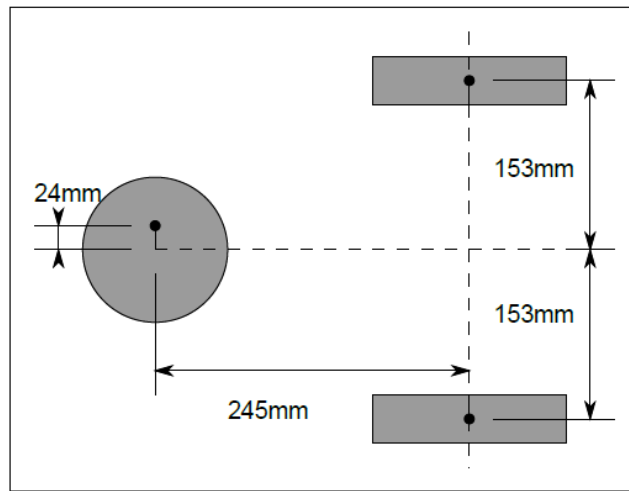

Figure 33: Position of the wheels in the base plate

The radius of the two bigger wheels is 10cm and for caster wheel (small one) is 3.5cm.

The critical points of the structure are given when one of the normal forces (N_1 , N_2 or N_3) reaches the value of 0 N, this means that the robot has lost contact with the floor in the wheel that the ground force is applied.

The aim for the model is to determine if the robot is stable with the current coordinates for the center of mass for the range of force applied. If the position for the center of mass doesn't allow to have a wide security factor before the structure overturns, it is necessary to change to change the position of it to find the HOBBIT stable.

In order to solve the equation system a Matlab code was programmed, where the normal forces N_1 , N_2 , N_3 , the friction forces F_{r1} , F_{r2} , F_{r3} and the hand support force F_h were unknown variables. It was studied in two different cases where $N_2=0N$ or $N_3=0N$ (critical cases). For each case the equation system was complete determinate, 5 unknown variables with 5 equations (One normal force and one friction force are zero because in the critical point there are only two contacts with the ground).

The supports were placed in the front of the robot in order to have the two big wheels as supports in the movement plane.

In general the function programmed in Matlab has as inputs:

- X_{cm} , Y_{cm} and Z_{cm}
- X_{c1} , Y_{c1} and Z_{c1}
- X_{c2} , Y_{c2} and Z_{c2}
- d_1, d_2 and d_3
- W
- Θ
- F_k

- α
- β

And outputs:

- F_h is the force applied in the hand support
- N_1, N_2 and N_3 : Normal forces generated in the contact points with the ground
- Fr_1, Fr_2 and Fr_3 : Friction forces in Z direction

The equation system is completely linear. Thus by changing only one input while the others are static, it is possible to study the dependence of the model regarding the parameter is being changed. After a long period of iterations the best combination of parameters (with the best stability) was found.

The decision of placing the supports in the front of the HOBBIT was taken because the distance between the bigger wheels is longer than the distance between the caster wheel and the axis of the other ones (d_2). But another option should be study in order to increase the opportunity of finding the best solution. In Figure 34 a model with the supports placed in one side of the robot is shown.

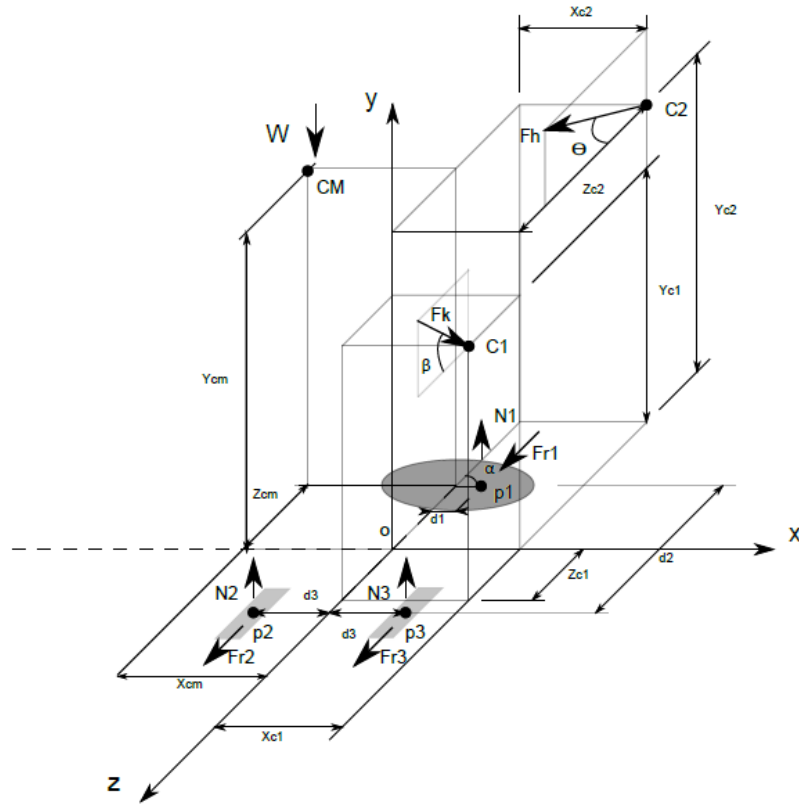

Figure 34: Physical model to study the balance of the HOBBIT with the supports placed in the lateral side

This model can be study with the following equations:

$$\sum F_y = -W + F_h \cdot \sin(\theta) - F_k \cdot \sin(\beta) + N_2 + N_3 = 0 \quad (7)$$

$$\sum F_z = -F_k \cdot \cos(\beta) + F_h \cdot \cos(\theta) + Fr_2 + Fr_3 = 0 \quad (8)$$

$$\sum M_{ox} = -Y_{C1} \cdot F_k \cdot \cos(\beta) + Y_{C2} \cdot F_h \cdot \cos(\theta) + Z_{C2} \cdot F_h \cdot \sin(\theta) - Z_{cm} \cdot W + Z_{C1} \cdot F_k \cdot \sin(\beta) - \frac{d_2}{2} * N_2 - \frac{d_2}{2} * N_3 = 0 \quad (9)$$

$$\sum M_{oy} = X_{C1} \cdot F_k \cdot \cos(\beta) - X_{C2} \cdot F_h \cdot \cos(\theta) + d_3 * Fr_2 - d_3 * Fr_3 = 0 \quad (10)$$

$$\sum M_{oz} = X_{C2} \cdot F_h \cdot \sin(\theta) + X_{cm} \cdot W - X_{C1} \cdot F_k \cdot \sin(\beta) - d_3 * N_2 + d_3 * N_3 = 0 \quad (11)$$

7 RESULTS AND ANALYSIS

The laboratory results, the respective analysis and the final proposal are presented in this chapter which is divided into five parts: the results from the laboratory, kinematic study, the stability study, elderly people tests and the final design summary.

7.1 LABORATORY RESULTS

The laboratory allowed to obtain the force and the position of the markers along the time. For that reason this section is divided in force values and coordinate position.

In general, for every test the forces and the coordinates were measured while the user was pushing and then pulling the handle. For the knee support, it is possible to apply load in only one direction, thus for both cases the user was pushing with his or her leg.

The effect of the angle “ β ” was studied during the calibration process, and it was concluded that it does not influence in the final results. This angle only forces the user to place the contact leg further back (better for the Sit-to-Stand movement). For this reason, during the measurement process the angle “ β ” was fixed between 35°-45° (this range was comfortable for all the volunteers)

7.1.1 Force values

Regarding the forces measurement, the data was collected in a text file. In order to interpret the information a Matlab file was programmed as it can be seen below. The code is explained carefully with the purpose of giving an idea of the calculation process.

Note: The green sentences are comment in the code to explain the purpose of the command.

```

Xo=[]; %Reference values measured directly from the sensors when the force applied is zero.
Column one for the values of the sensor at the knee support and the others for the handle sensor
Yo=[0 0 0]; %Reference values of the forces (0N)
S=[]; %K value calculated for each sensor
X=[];% Values measured directly from the sensors
[B,A]=butter(2,0.02,'low'); %Filtering process
Y=filtfilt(B,A,X); %Filtering process
a=(1:length(X))*(1/1000); %The sample frequency used was 1000Hz
Yn=10*[ (S(1)*(Y(:,1)-Xo(1)))+Yo(1) (S(2)*(Y(:,2)-Xo(2)))+Yo(2) (S(3)*(Y(:,3)-
Xo(3)))+Yo(3) ]; %Force calculation expressed in Newton
Yn=[Yn(:,1) Yn(:,2)+Yn(:,2)]; %Here the column one is added to the third one in order to
calculate the total handle force
hold on
plot(a,Yn(:,1)) %Plot commands
plot(a,Yn(:,2),'r')

```

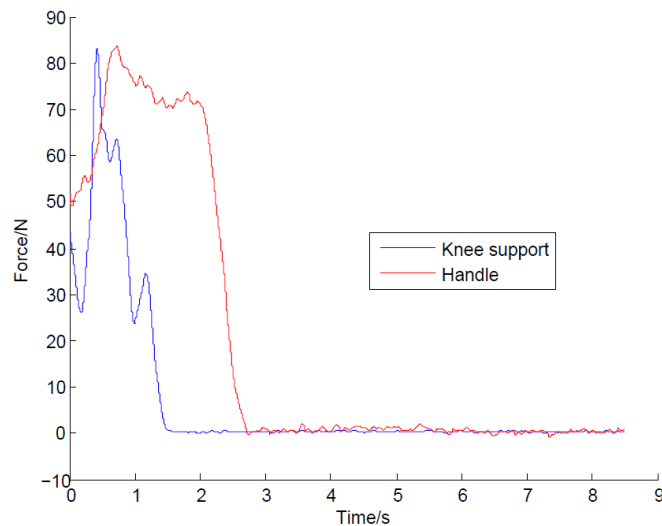

Figure 35: Example of the results of the force measuring process (pushing handle)

After applying the code to the data coming from the sensors, the forces during the interaction of the user with the prototype were calculated and plotted. Figure 35 shows an example of the Matlab output. It is important to mention that the results did not depend on the mass or the height of the volunteer, but the results were always accurate for the same user. The main conclusion was that the force depends on the user's Sit-to-Stand technique, if he or she follows the instruction described for a safer movement (Theoretical framework, movement techniques).

For this section the main goal was to determine the maximal values the user could apply to the prototype. The critical forces were obtained before explaining the volunteer how to perform a right Sit-to-Stand movement. The results shown below correspond to the worst cases. The subject (a man) mass is 83Kg and height of 1.82m.

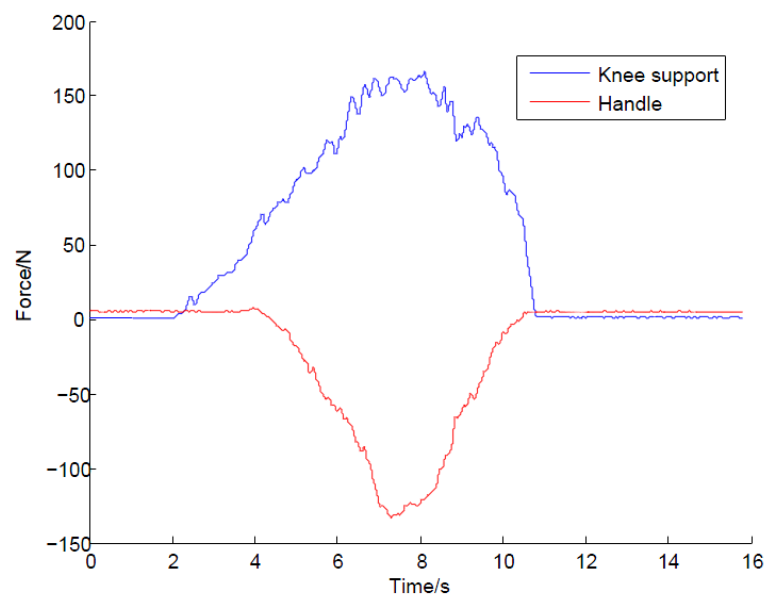

Figure 36: Force applied to the supports, worst case (pulling)

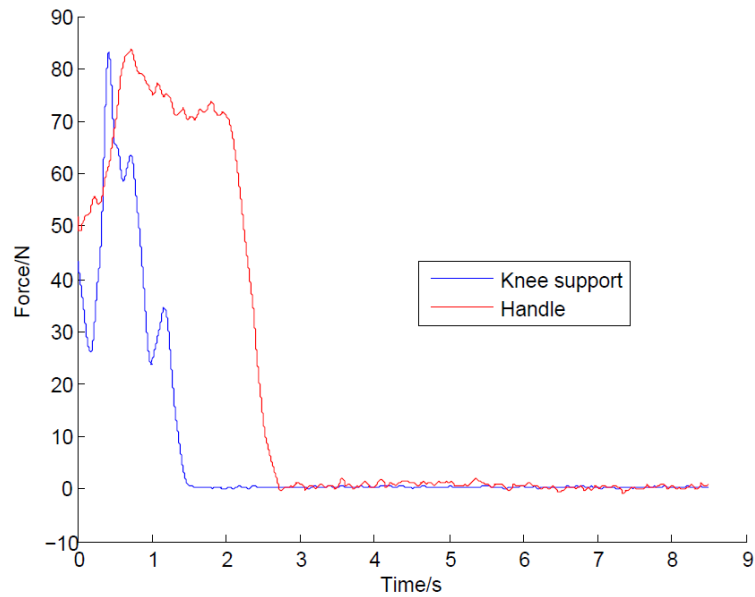

Figure 37: Force applied to the supports, worst case (pushing)

Figure 36 and Figure 37 show the maximal forces obtained in the laboratory for the two different cases, pushing or pulling. For pulling case the force measured has negative values, it is because the sensors are in tension (the positive value of deformation was defined for compression). As it could be seen in the figures, the load applied for pushing are lower, but in the same direction. Furthermore, the first case presents higher values for all the volunteers and the forces are applied in different directions.

On the other hand, for the pulling case it was necessary to estimate the relation between the force applied in the knee support and the handle. The results of this case for different users showed the same behavior and changes only in the magnitude.

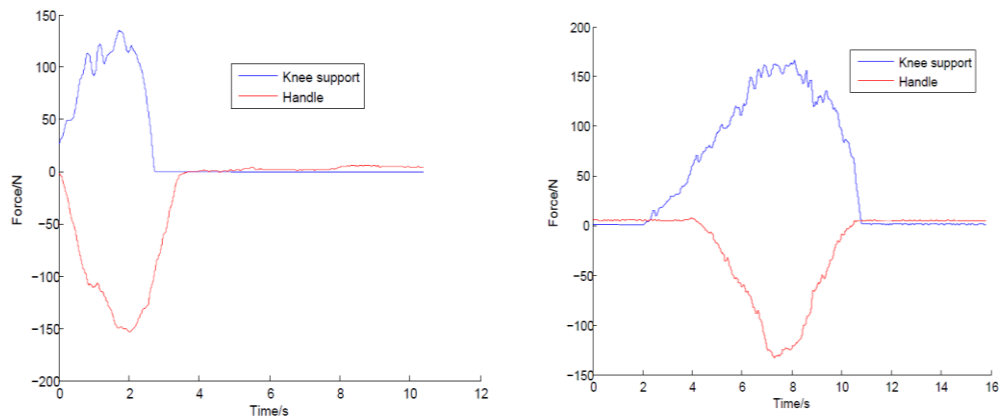

Figure 38: Results of the force for the pulling case for two different users

In

Figure 38 the values of the forces for different users when they are pulling can be seen. The magnitude of the loads for both supports is almost the same, it is due to the user tries to balance his or her body as possible while the Sit-to-Stand movement. This behavior was exactly the same for all the measurement. Consequently, it is possible to affirm that the ratio of both forces is one to one.

Resuming, Table 4 shows the results of the maximal forces determined in this section used for the following calculations. These values were obtained with the worst cases but a security factor of 1.5 was used to decrease the risk of failure for the final proposal.

Table 4: Maximal values of the force

Parameter	Pulling case		Pushing case	
	Fk [N]	Fh [N]	Fk [N]	Fh [N]
Minimal value	0	0	0	0
Maximal value	150	150	100	100
Maximal value (with security factor)	225	225	150	150
Worst case	225	225	150	150

7.1.2 Coordinate position

At the same time as the forces were recorded, the motion capture system saved the position of each marker every millisecond, which allowed to import the collected data into OpenSim to start the kinematic study (this process is explained in the importing the motion data section).

7.2 KINEMATIC STUDY

With the coordinate position data along the time already defined in a .trc file, the next step to study the kinematics was the model building process. The geometry files for the user bones were downloaded from the OpenSim web page [6], the handle was created in SolidWorks and imported to OpenSim software using binary files. In Figure 39 a preview of the model could be seen, the red dots represent the virtual markers.

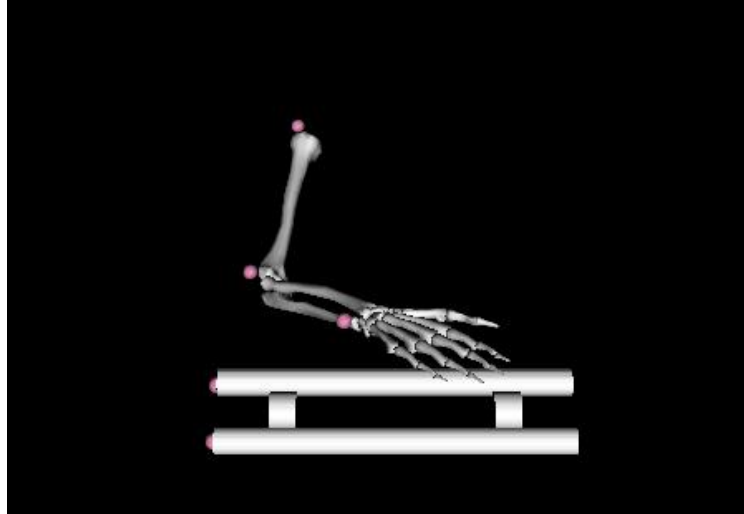

Figure 39: Preview of the OpenSim model with the handle

Having defined the model and the data already imported to OpenSim, the following step was to program the XML files in order to apply the scale and inverse kinematic tools as it was explained in the models and validation chapter. Figure 40 shows a sequence an animation of the results obtained after applying these tools.

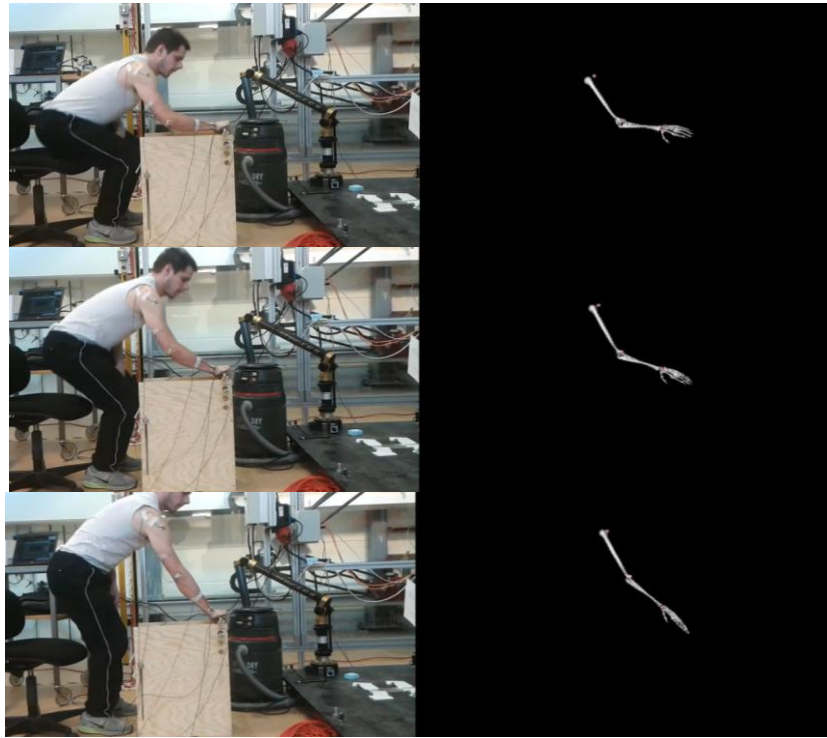

Figure 40: Animation resulted from the inverse kinematic tool

The main objective of the OpenSim model was to determine the application force angle in the handle (θ). As the support for the hand is allowed to rotate around the pivot point, the desired angle is the one defined from the handle to the horizontal (Figure 41), it is because the handle will rotate according to the direction the user applies the force.

On the other hand, another important parameter determined was the elbow flexion angle (δ) that determines the flexibility the user should have to be able to perform a natural Sit-to-Stand movement; this angle is shown in Figure 41.

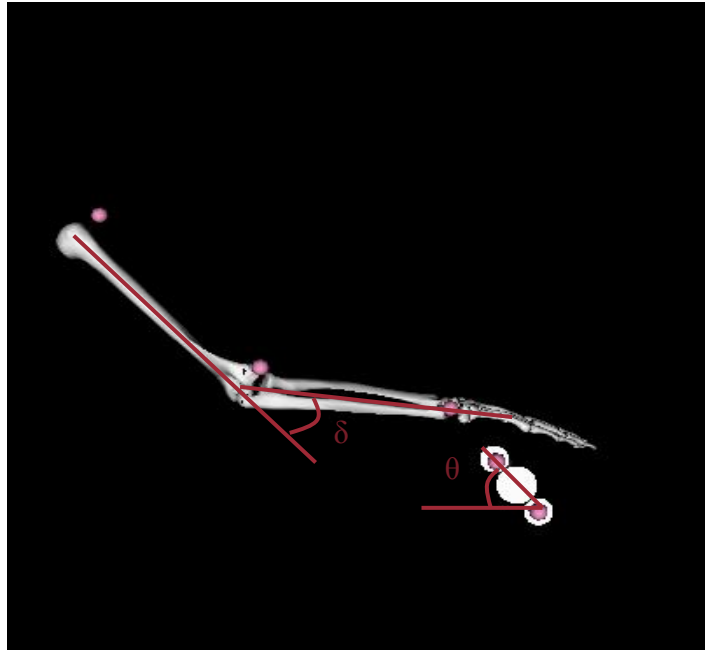

Figure 41: Elbow flexion and handle angles

The values of the angles were calculated with OpenSim for different users. For this report the results are shown for the best simulation (the shortest distance between virtual and real markers). In the following graphs θ and δ should be seen for both cases, pushing and pulling.

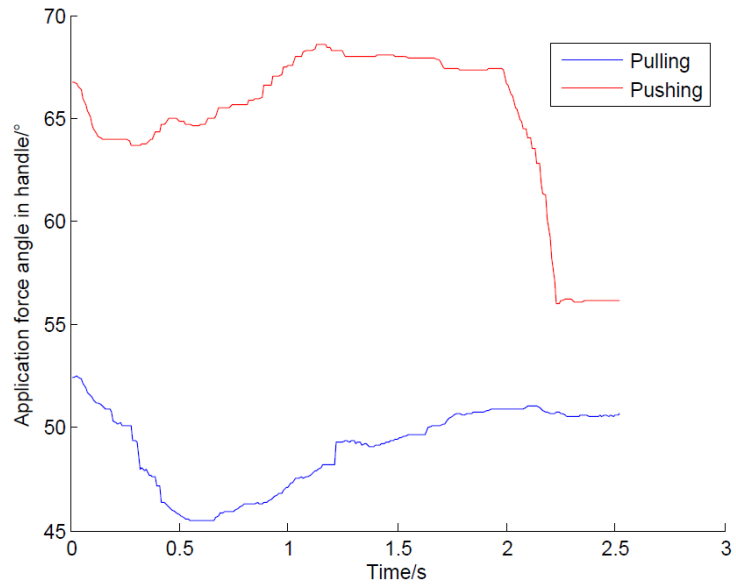

Figure 42: θ angle Vs time for pushing and pulling case

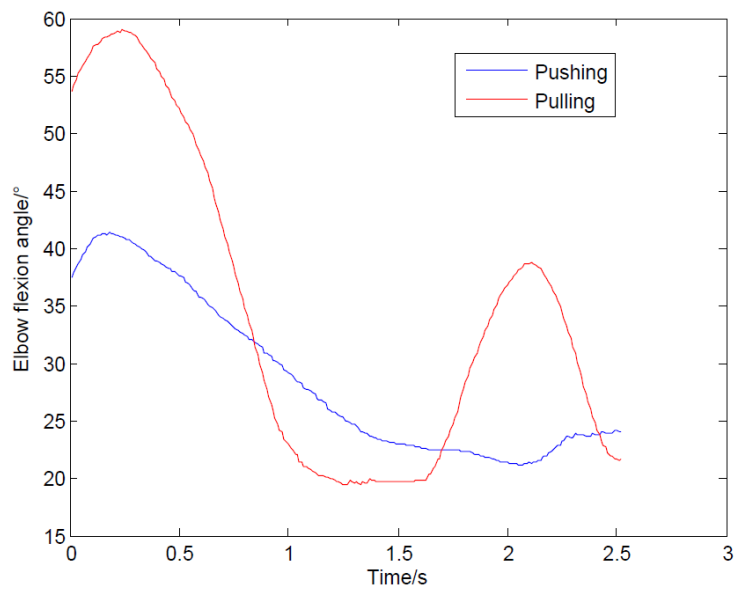

Figure 43: δ angle Vs time for pushing and pulling case

From Figure 42 it is possible to conclude that the θ angle is higher for the pushing method in any case, the critical values observed in all the laboratory tests are shown in Table 5, the values for the elbow flexion can be found as well.

Table 5: Critical values for δ and θ angles

	Pushing	Pulling
Max θ [°]	70	55
Min θ [°]	55	45
Max δ [°]	45	60
Min δ [°]	20	20

Finally, the range determined the user should be able to move is between 20 ° up to 60 ° for the elbow flexion, in order to perform a naturally and comfortable Sit-to-Stand movement with the help of the prototype.

7.3 STABILITY STUDY

Having the forces and the kinematics defined, all the parameters required to start the stability analysis were defined. The Matlab model (the code can be found in the appendix) solves the equation system applying the Gauss-Jordan method (equations 2, 3, 4, 5, 6). The program could be interpreted as the following function:

$[Fh, N1, N2, N3, Fr1, Fr2, Fr3]=\text{function}(Xcm, Ycm, Zcm, Xc1, Yc1, Zc1, Xc2, Yc2, Zc2, d1,d2, d3, W, \Theta, \alpha, \beta, Fk)$

Before starting the simulations, the cases of study were defined. As the model of the movement was established in only two dimensions, the two critical possibilities are presented when: first N2 reaches 0N or second when N3 reaches 0N, it means the points are losing contact with ground. Figure 44 helps with the understanding of these two cases. There are no forces that could implied a third case when the point 1 (p1) loses the contact with the ground.

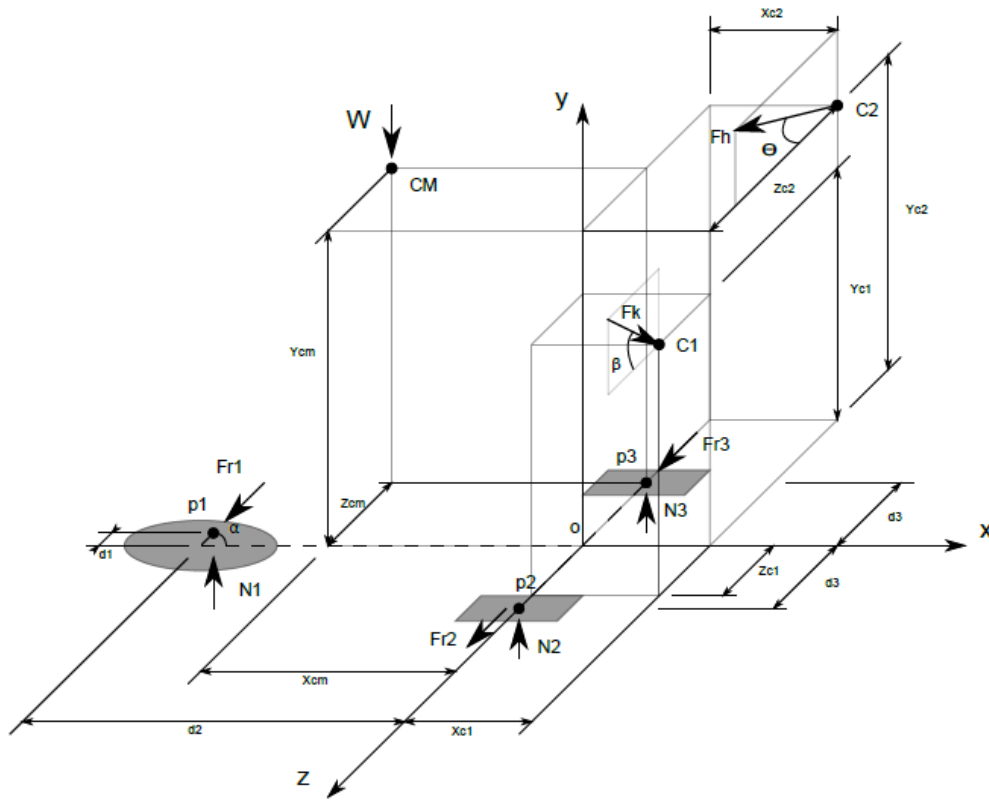

Figure 44: DCL of the physical model of the proposal

The defined protocol was to fix all the inputs with logical values, and then start changing individual parameters. In order to interpret the results and the behavior of the structure, the Matlab code solved the equation system for different values of F_k (from 0N up to 360N) for fixed values of X_{cm} , Y_{cm} , Z_{cm} , X_{c1} , Y_{c1} , Z_{c1} , X_{c2} , Y_{c2} , Z_{c2} , d_1, d_2, d_3 , W , Θ , α , β . An example of the output coming from the program is shown in Figure 45

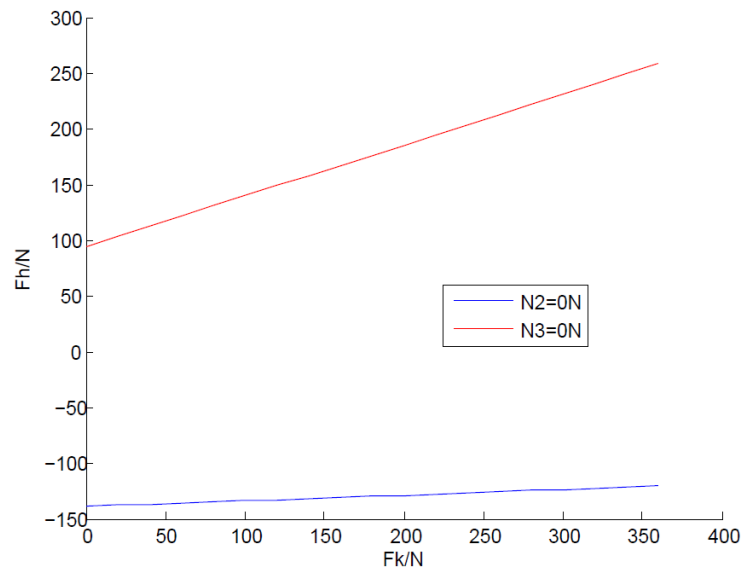

Figure 45: Example of the output of the Matlab code

In Figure 45, the red curve represents the maximal values of F_h before turning around the contact point 2 when a specific F_k is applied, the positive values indicate that in order to reach those loads the user has to “pull” the handle. Furthermore, the blue curve shows the opposite case, the maximal value for the pushing force in the handle.

The optimization process consisted in finding the best configuration where the area between the two curves presented in Figure 45 is maximal. The final solution has to be logical according the physical position of the supports. This process was composed by several iterations, an example of the optimization of one parameter is described with the purpose of showing the followed methodology.

The example below corresponds to the optimization process for the β angle. It started fixing X_{cm} , Y_{cm} , Z_{cm} , X_{c1} , Y_{c1} , Z_{c1} , X_{c2} , Y_{c2} , Z_{c2} , d_1, d_2, d_3 , W , Θ , α in standard values. Then the process started by changing the values of the tilt angle to see the behavior showed by the structure. Figure 46 shows the results for this process.

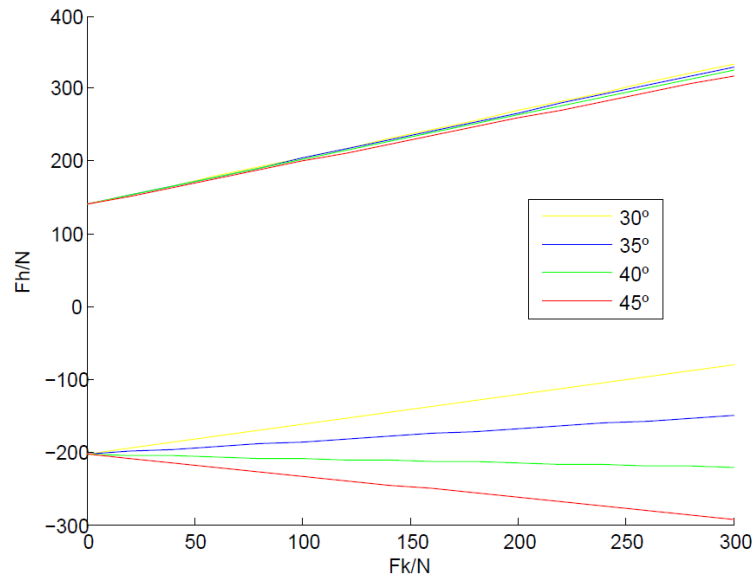

Figure 46: Optimization process for the β angle

The optimization process for the β angle demonstrated that increasing this angles the structure is safer. It is in line with the reality, as bigger β is, the horizontal component of F_k is lower, and this component is one of the main responsible for the rotation around the X direction.

The angle θ depends on the user movement, and it was determined in the optimization process that as low it is, the structure is less stable. For that reason the angle was fixed in 40° for the calculations. It is less than the worst case registered at the laboratory. On the other hand, the angle used for α was 0° (found as the worst case).

Applying this methodology for every parameter is was possible to optimize the structure at the most. The results for this process are shown in Table 6 (for the coordinate system defined in Figure 44). In Figure 47 the safety area can be seen.

Table 6: Proposal for the physical distances of the support and center of mass

	Coordinates		
	Z [mm]	Y [mm]	X [mm]
Hand Support	200	500	270 up to 350
Knee Support	150	350 to 450	270
Center of Mass	20	As low as possible	80 up to 100

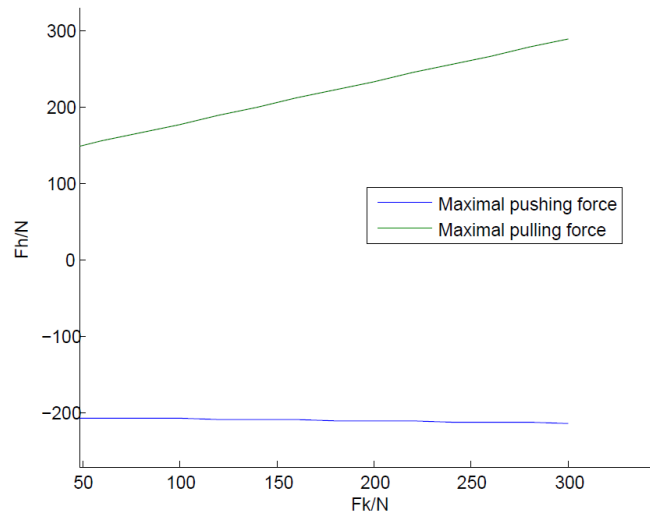

Figure 47: Safety area for the final proposal

Figure 47 shows the critical forces for the final proposal. As it can be seen, for the pushing case the structure has a security factor of 2, it means than the maximal forces found in the laboratory sessions are lower than a half of the critical forces for this structure. However, for this case of study the friction forces are assumed big enough to avoid any displacement, it is recommended for future studies to determine the friction factor between the wheels and the surfaces in order to improve the model.

On the other hand, for the pulling case the structure can afford up to 150N (the maximal force found in the laboratory) in the handle support when there is no force applied in the knee support. But this limit increase when the leg is in contact with the support as it could be seen in Figure 47 (because this force is opposed to the force applied in the handle). So long as the user does not lose contact with the knee support the structure will have a wide security factor for this case. For that reason the final design should include signals to avoid the user to start the movement if his or her knee is not in contact with the device.

Finally, placing the supports in the front of the HOBbit, the best solution was found. It was hard to find a solution with the alternative model (with supports in the lateral side), because big changes in the center of mass coordinates should be done in order to have a stable structure.

7.4 ELDERLY PEOPLE TESTS

With the purpose of confirming the credibility of the project, the prototype was tested with 4 elderly people between 83 and 90 years old. The results of the forces never reached the values found during the laboratory tests with younger people, this can happen due to the elderly people performed the movement carefully and slower.

After applying the surveys, it was found that the shortest users (155cm and 163cm) did not need any help to stand up, and the expressed they would not use a Sit-to-Stand device. However, they found the prototype comfortable specifically using the pulling method. The pushing method did not satisfied all the users.

On the other hand, for the other (185cm for both) the results were complete different, especially for one of the volunteers who has problem in hips and knees. They were pleased with the device, it was found useful, comfortable and necessary.

Finally, with these tests it is possible to conclude that this device satisfies the necessities, and could simplify the lifestyle of the users with a lack of balance or strength to perform a safe Sit-to-Stand movement.

7.5 FINAL DESIGN SUMMARY

In resume, the final design consists in two supports, one handle and one knee support as it was described in option 2 (Figure 18). After the optimization process the distances for the supports and the center of mass where found and are shown in Table 6. The β angle should be fixed in 40° and the knee support should be able to move in the vertical direction in order to find the best position for the user. During the tests, the users did not find significant differences in using the right side of the body or the left one to perform the movement. For that reason in Figure 48 a proposal is shown with the supports placed in order the user would use the right hand and right knee, unlike the models showed before. It means that the supports could be manufacture in both directions, it is only necessary to consider the coordinate system defined.

Note: The distances proposal are referred to the coordinate system defined in Figure 44, and the center of mass of the HOBBIT includes the supports.

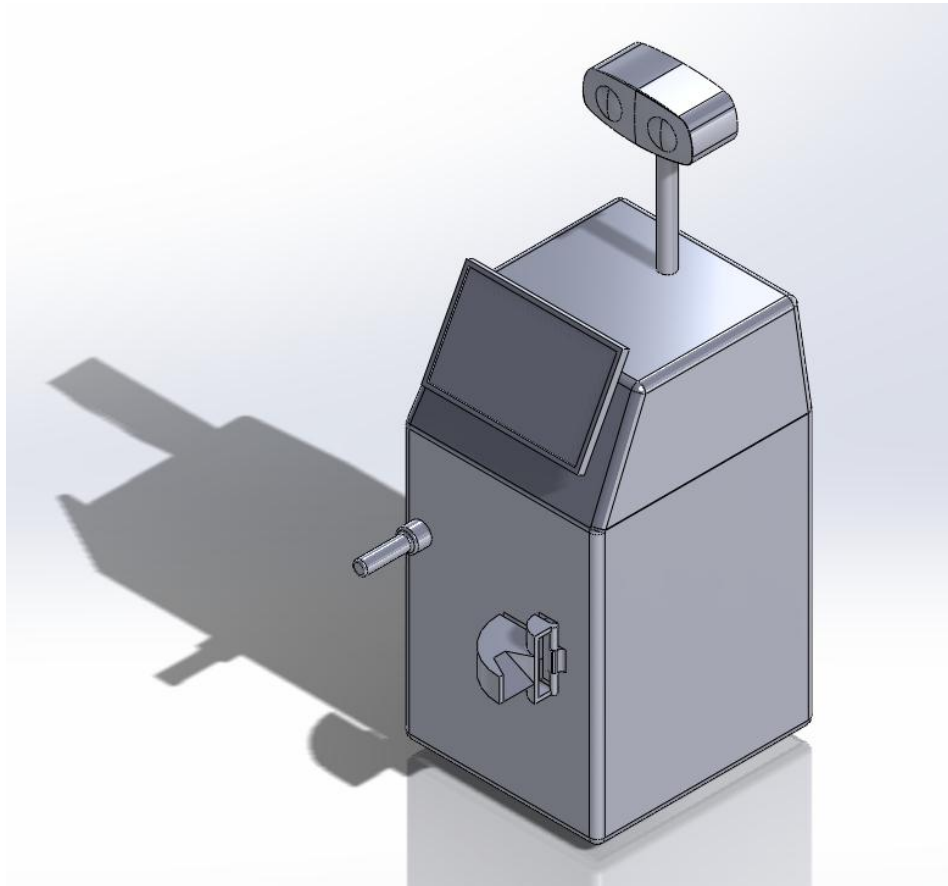

Figure 48: Final proposal integrated to the HOBBIT

Finally, an animation with the final CAD model was performed in OpenSim in order to visualize the interaction of the user's arm and the HOBBIT. A sequence of pictures can be seen in Figure 49. This simulation allows to conclude that the screen of the robot should be placed at the same level than the front face of the robot or behind, in that way it will not interfere with the movement.

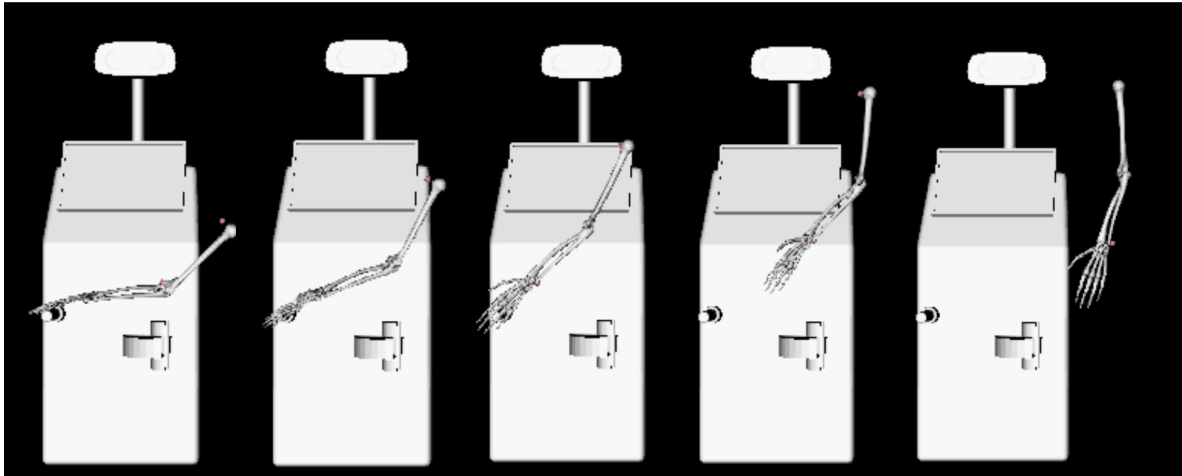

Figure 49: Pictures sequence of the interaction of the user with the HOBBIT and the final proposal

8 CONCLUSION

The main objective of this master thesis work was reached successfully. A rise support was designed and tested and the verification process demonstrated the feasibility of including this design in the HOBBIT project with a security factor of 1.5.

The model of the rise-up device improves the stability of the user during the Sit-to Stand movement, keeping the balance of the HOBBIT robot. The position of the supports forces the user to a good initial position for the movement, reducing the risk, of falling and the torque required in hips and knees.

This design proposal should be possible to integrate to the latest version of the robot HOBBIT but a change of the position of the screen on the top of the robot should be considered, in order to allow the user to reach a standing position with a natural movement (The current position of the screen could crash with user's shoulder).

The following information is suggested for future researches:

- Study the friction factor between the wheels and different surfaces in order to improve the stability model proposed in this project.
- Develop security signals in order to notify the user that he or she is in a good position to perform the movement.
- Design a mechanics to allow the knee support a vertical displacement.
- Built a full body OpenSim model in order to apply the inverse dynamic to study the impact of the proposal in the muscle forces.

9 APPENDIX

The following Matlab code was used to generate the results of the 7.3 section.

```
N=360; %Maximal value for Fk [N]

%Define all the parameter of the robot in N and m

alpha=180*pi/180;
beta=40*pi/180;
tita=30*pi/180;
d1=0.024;
d2=0.245;
d3=0.153;
W=800;
f=d2-(d1*cos(alpha));
Xc1=0.215;
Yc1=0.4;
Zc1=0.2;
Xc2=0.215;
Yc2=0.5;
Zc2=0.2;
Zcm=0.0;
Xcm=0.12;

max=(N/20);
x=0:20:N;
y=zeros(2,max);

for l=2:3 % 2 when N2=0 or 3 when N3=0
D=l;
if D~=2 && D~=3
    disp('error, D is diferent than 2 or 3')
    break
end

for i=1:20:N+1

    Fk=i;
    b=Fk*sin(beta);
    c=Fk*cos(beta);
    b=[b+W; c; Yc1*c+Zcm*W-Zc1*b; -Xc1*c; Xc1*b-Xcm*W];
    if abs(D-3)<=0.001
        A=[1 1 0 0 sin(tita); 0 0 1 1 cos(tita); 0 -d3 0 0 (Yc2*cos(tita)+Zc2*cos(tita)); 0 0 f 0 -Xc2*cos(tita); -f 0 0 0
Xc2*sin(tita)];
        o=2;
    else
        A=[1 1 0 0 sin(tita); 0 0 1 1 cos(tita); 0 d3 0 0 (Yc2*cos(tita)+Zc2*cos(tita)); 0 0 f 0 -Xc2*cos(tita); -f 0 0 0
Xc2*sin(tita)];
        o=3;
    end
end
```

```
end
```

```
X=A\b;
```

```
fprintf('N1 = %4.1f N%1.0f = %4.1f Fr1 = %4.1f fR%1.0f = %4.1f Fh = %4.1f \n',X(1),o,X(2),X(3),o,X(4),X(5))
```

```
j=1+(i-1)/20;
```

```
y(1-1,j)=X(5);
```

```
end
```

```
end
```

```
hold on
```

```
xlabel('Fk/N')
```

```
ylabel('Fh/N')
```

```
plot(x,y(1,:))
```

```
plot(x,y(2,:),'r')
```

10 REFERENCES

- [1] United Nations, "World Population Ageing: 1950-2050," United Nations Publications, New York, 2001.
- [2] P. S. C. E. A. F. T. R. M. J A Stevens, "The costs of fatal and non-fatal falls among older adults," Injury Prevention, Atlanta, 2006.
- [3] J. Boehlke, "Definition of Caring for Elderly," *Livestrong*, 2013.
- [4] W. J. Ting GHY, "Elder care: is legislation of family," Journal of Clinical Gerontology and Geriatrics, Hong Kong, 2009.
- [5] J. Flaherty, "Putting the Whee! Back in Wheelcahir," Wired design, 2012.
- [6] HOBBIT (Electronic), "<http://www.hobbit-project.eu/>," 26 06 2013. [Online].
- [7] E. P. Doheny, "Falls classification using tri-axial accelerometers during the five-times-sit-to-stand test," El Sevier, Dublin, 2013.
- [8] D. W. Kevin Simonton, "Frequently Asked Questions about Sit-to-Stand Patient/Resident Devices," Department of Labor and Industries, Washington, 1999.
- [9] J. M. Torán, "Metodología del diseño," [Online]. Available: <http://metodologiadisenousb.blogspot.se/>.
- [10] B. R. R. P. e. a. Schenkman ML, "Whole-body movements," 1990.
- [11] H. B. B. a. H. J. S. Wim GM Janssen, "Determinants of the Sit-toStand movement: A review," 2002.
- [12] ACC, The New Zealand Patient Handling Guidelines, 2003.
- [13] VanCare, "VanCare," [Online]. Available: <http://www.vancare.com/index.php/veraii-b450>.
- [14] Handicare, "Handicare," [Online]. Available: <http://www.handicare.se/en-us/USA-Start/Transfer--Lifting/Products/Manual-transfer-aids/Sit-to-stand-aids/ReTurn7100/>.
- [15] Handicare, "Handicare," [Online]. Available: [transfer-aids/systemromedic---assistive-devices-for-mobility-support-during-sit-to-stand/systemromedic---quickmove/c-39/c-204/p-296](http://www.handicare.se/en-us/USA-Start/Transfer--Lifting/Products/Manual-transfer-aids/Sit-to-stand-aids/ReTurn7100/).
- [16] R. K. Y. H. a. Y. S. Atsushi Tsukahara, "Sit-to-Stand and Stand-to-Sit Transfer Support for Complete Paraplegic Patients with Robot Suit HAL," 2009.
- [17] P. M. D. S. E. A. D. a. G.-Z. Y. David P. Noonan, A Stereoscopic Fibroscope for Camera Motion and 3D Depth, Kobe: IEEE International Conference on Robotics and Automation, 2009.

- [18] University of Michigan, "University of Michigan 3D Lab," [Online]. Available: <http://um3d.dc.umich.edu/portfolio/how-it-works-mocap/>.
- [19] Simtk, "OpenSim," [Online]. Available: <https://simtk.org/home/opensim>.
- [20] G. Larsson, "Uppresningsstöd hos en servicerobot för äldre människor," LTH, Lund Universitet, Lund, 2013.