

Master Thesis

Sound Analysis

An intelligent device produced with CAD and CNC machinery
using Industrial design and product development methods

Michael Rapp

Division of Machine Design • Department of Design Science

Faculty of Engineering LTH • Lund University • 2012



LUND UNIVERSITY

IPsense

Sound Analysis

An intelligent device produced with CAD and CNC machinery
using Industrial design and product development methods

Michael Rapp

*Division of Machine Design • Department of Design Science
Faculty of Engineering LTH • Lund University • 2012*

Division of Machine Design, Department of Design Science
Faculty of Engineering LTH, Lund University
P.O. Box 118
SE-221 00 Lund
Sweden

ISRN LUTMDN/TMKT 12/5445 SE

Acknowledgement

This Master Thesis was made during winter/spring of 2012. The work has been done on Department of Design Sciences and Machine Design, Faculty of Engineering, Lund University in collaboration with IPsense AB. The task has been to research and develop the housing for an electronic device made for sound analysis. This thesis is the final step in the Master Program (M.Sc) of Mechanical Design Engineering a combined 5 year program of Mechanical Engineering and Industrial Design at Lund University, Sweden.

I would like to thank Mikael Jansson President of IPsense AB and supervisor for the project. His input, support and know how throughout the development process has been very valuable. Also I would like to express my gratitude to Lecturer Karl-Axel Andersson, supervisor at Division of Industrial Design for the input regarding technical aspects of the product. In addition, thanks to Lecturer Per Liljeqvist at Division of Industrial Design, mentor within Industrial Design concepts. Also thanks to PhD Candidate Anders Sjöström at Division of Structural Mechanics, Lund University that helped performing a most valuable sound test. Thanks to Hanna Colleen, student at the Design Engineer Master program that was helpful with flowcharts and illustrations.

Regarding the workshop, Jonny Nyman deserves a special thank for his work throughout the CNC-process having produced the prototype to perfection. I also would like to thank Göran Larsson for the support in the workshop.

The big appreciation within this project is directed to Associate Professor Giorgos Nikoleris at Division of Machine, Design Faculty of Engineering, Lund University who was the main supervisor. His dedication, patience and problem solving skills have been most crucial to the outcome in the process of producing the β -prototype.

Lund, July 2012

Michael Rapp



Abstract

This Master Thesis will cover the development of the mechanics and design aspects for a new product innovation made for IPsense AB (at Lund Technical University and Ingvar Kamprad Design Center in Lund, Sweden). Due to the sensitivity of the project some information has been left out.

The product is part of an IP-based network concept developed for analyzing sound in real time. The total concept also involves software solutions integrated with a sound analyzing interface.

The task was to design and develop the mechanical parts for a new concept. The goal of the thesis was to develop a solution in how to mechanically and ecstatically design the optimum electronic housing that will cope with the technical specifications given being possible to manufacture in smaller series.

The result offers a good balance within design, sound design and flexibility. To achieve this, the product design was made modular using CAD, produced with CNC-machines for a rapid production in small series.

Looking at the current situation:

- Which are the customer needs for such a product
- What products exists in the marketplace

Further on:

- Research and analyze customer needs and design issues
- Choose the best housing-solution for prototyping
- Manufacture and test the prototype

Keywords:

Mechanical design, Industrial design, CAD, CNC, CCTV, IP network, sound analysis, sound pressure, sound gain, dB

Summary

IPsense AB erbjuder konsulttjänster inom produktutveckling och mjukvaruutveckling, de använder också sina expertkunskaper inom nätverkskommunikation och data kommunikation. IPSense har även lång erfarenhet av produktutveckling från kundprojekt och egna projekt. I deras portfolio låg ett nytt konfidentiellt koncept bestående av ett system för ljudanalys. Vissa delar i systemet var i de närmaste färdigutvecklade, det som återstod var mekaniken att montera komponenterna i.

Produkten fungerar som intelligent mikrofon för att analysera ljud i sin omgivning. Uppgiften som gavs av Mikael Jansson På IPSense var därför att utforma en design på inkapslingen som kunde återge ljud oavsett placering i rummet samt framställa den i en prototyp som både kunde fungera i en kontorsmiljö men även ihop med en industriell applikation. Detta innebar även att utveckla mikrofonens utformning och placering.

Metoden på Masterarbetet följer i stort sett Ulrich & Eppingers metod för koncept generering kombinerat med industridesign metoder som tillämpas på IKDC, Lunds Universitet. Det började med att insamla kundbehov på marknaden för att verifiera idén. Detta gjordes med en internetbaserad marknadsundersökning kopplad till expertgrupper på internet. Genom den samt genom omröstningar gällande olika frågeställningar sammanställdes informationen i ett dokument. Därefter omtolkades dessa till målsspecifikationer, en sk. "need list" togs fram vilket visade hur väl konceptet till sin helhet passade in, därefter rankades dessa. (P.g.a. att konceptet innehöll känslig information bestämdes att vissa typer av frågeställningar skulle tas bort).

Efterhand att marknads behov gjordes kända togs ett material fram för att skapa idéer kring produktutformningen. I Industridesign-sammanhang används ofta en sk. "Mood Board" för att visualisera konceptidén kombinerat med skisser och modeller, vilket framställdes. Parallellt, efter färdigställande av målsspecifikationerna genomfördes en "Screening och Scoring"- utvärdering vilket resulterade i en vinnande designlösning. Produktlösningen innebar en rund "burk med gängat lock" där designen i locket var utformad med en mjuk konvex bågform. Inspirationen till designen kom genom att undersöka ett öras utformning där ytterörats utformning är riktningkänslig för ljud. Ett antagande gjordes att designen kunde öka ljudtrycket mot mitten, där mikrofonen skulle placeras, i liv med locket, något som skulle visa sig vara korrekt.

Allt eftersom designlösningen blev färdig togs en prototyp fram manuellt i syfte att undersöka gängans utformning, designen av ”burken”, dess inre funktioner samt lockets förmåga att förstärka ljudtrycket. Efter utvärdering gjordes en andra prototyp med hjälp av CAD, därefter exporterades filerna till styrsystemet till CNC-fräs och svarv. Arbetet att ”översätta” filerna var tämligen tidskrävande då detta gjordes genom handpåläggning av resp. CNC-process, såsom håltagning, yt-planing etc. Processen ansågs ändå effektivare än att arbeta med jämfört med CREO:s egen funktionalitet för att CNC-beredning.

Tester utfördes gällande ljudupptagning, vattentätthet och värmebelastning. Ljudtestet genomfördes på Divisionen för mekanisk struktur i ett ljuddött rum med en datainsamlingsenhet kopplad till testriggen. Det utfördes tre olika tester för att kontrollera designens inverkan på ljudtrycket. Gällande vattentestet gjordes detta med en högtryckstvätt under liknande förhållande som beskrivs med kodningen IP66/65. Produkten monterades på en träställning varpå vatten sprutades mot den. Värmetestet genomfördes med elektroniken inbyggd i syfte att kontrollera att CPU:n i kretsen klarade att köras med 100% belastning utan att bli överhettad.

Resultatet av projektet har utvärderats efterhand. En inkapsling för elektroniken har framställts upp till β -prototyp. Designen av lock-utformningen har gett ett tillfredsställande resultat, genom tester påvisas att ljudtrycks-gradienten (dB) kan öka upp till ca 35 dB. Resultatet kommer ge upphov till att ett designskydd eller patent kommer att sökas för detta. Vattentestet visade att ett visst läckage uppstod i en av O-ringstättningarna vilket innebär att vidare undersökning bör läggas ner på detta för att klassingen skall kunna uppnå IP66/65. Genomfört värmetest visade inga tecken på överhettning varpå detta blir godkänt.

Jämför man slutligen de tekniska specifikationerna givna för projektet och målspecifikationerna som framkom ur marknadsundersökningen med den färdiga β -prototypen kan man konstatera att den inte är perfekt men projektet som helhet måste anses som mycket lyckat.



Bilden visar den färdiga produkten

Table of Contents

1 Introduction	1
1.1 Background	1
1.2 Objectives.....	2
1.3 Limitations	2
1.4 Chapter distribution	3
2 Methodology	5
2.1 Introduction.....	5
2.2 Implementation of the thesis	5
2.3 Methods used.....	6
2.4 Prototype Development Process.....	9
2.5 Product Tests	9
2.6 Iterative Working Process	10
3 Theoretical Basics of Product Development.....	11
4 Product Concept Development.....	15
4.1 Product Specification – IPsense	15
4.2 Product Development Limitation	15
4.3 The Market Need – Which is it?	16
4.3.1 Identifying customer needs.....	16
4.4 Industrial Design approach.....	19
4.4.1 Mood Board.....	20
4.4.2 Sector Diagram.....	21
4.4.3 Target Group Segmentation	22
4.4.4 Design Brief	23
4.4.5 Function Analysis	25
4.5 Mechanical Design Approach	25
4.5.1 Concept Generation	25
4.5.2 Concept Screening	29

4.5.3 Concept Scoring.....	30
4.5.4 Modular Design Concept.....	32
4.6 Sound Design.....	33
4.6.1 Sound Design – Limitations.....	34
4.6.2 Sound Design – Inspiration.....	34
4.6.3 Sound Concept – Evaluation.....	35
4.6.4 Sound Dish Design – Integration of microphone.....	36
5 Product Generation.....	39
5.1 Parts and Components.....	39
5.1.1 Mechanical Parts.....	39
5.1.2 Electrical Parts.....	40
5.2 Material Selection.....	40
5.2.1 The Plastic Material Pyramid.....	40
5.2.2 Plastic Evaluation.....	42
5.2.3 Steel parts.....	42
5.3 Production process.....	43
5.3.1 Rapid Prototyping.....	43
5.3.2 Resin casting.....	44
5.3.3 CNC – automated process.....	45
5.3.4 Production Evaluation.....	46
5.4 Prototyping.....	47
5.4.1 α -prototype Design – Handmade.....	47
5.4.2 α -prototype Design – Evaluation.....	52
5.4.3 β -prototype Design – CAD.....	53
5.4.4 Improvements for β -prototype.....	54
5.4.5 CAD – post processing.....	59
5.4.6 CNC – logistic sequence.....	60
5.4.7 β -prototype Design – Evaluation.....	61
5.5 Assembling β -prototype.....	61
5.5.1 Housing.....	62
5.5.2 Microphone.....	63
6 Product Testing.....	65
6.1 Sound Test – Set up.....	65
6.1.1 Sound Test – Results.....	67
6.1.2 Sound Test – Evaluation.....	70

6.2 Water resistance test – Set up	71
6.2.1 IP 66/65 Coding.....	71
6.2.2 Water resistance – Results.....	72
6.3 Heat Test – Set up	72
6.3.1 Heat Test – Results	73
6.4 EMC test.....	73
7 Reflections and discussion	75
8 Analysis and future improvements	77
Results	79
Reference list.....	81

1 Introduction

This chapter gives an introduction to this thesis. Background, objectives and limitations are described as well as the thesis chapter distribution and definitions.

1.1 Background

A sound analysis system is not yet a natural part of businesses. We see a development that implies that in addition to the classic systems there are also needs for more important support functions. Another issue is that different systems within an enterprise needs to be integrated with each other in an easy way and sometimes also with systems from suppliers, customers and / or partners.

A sound analysis system could also become more crucial in corporate strategies and survival. For example, the taxi industry, it is increasingly common for taxi drivers barely dare to work at night without a surveillance system installed.¹

The surveillance paradox

“- Today there are far greater opportunities for the community to monitor who we meet, how they move and where they meet. Monitoring is something we dislike, we want freedom. But we will find it difficult to opt out of the benefits of this huge amount of data can be collected.”²

¹ Swedish Parliament announces the Government of its meaning as in the motion cited on the licensing of video surveillance in taxis.

² The Swedish-American security researcher and political scientist Jan Kallberg visited Stockholm to talk about the threats and opportunities of the future Internet is facing, Tech World.

IPsense

IPsense AB is an innovative company, working with product development from software to hardware, specifically pertaining to sound analysis. IPsense also provides qualified consultancy services within embedded system development. The company was founded by Mikael Jansson.

Mission Statement

IPsense are currently developing a product concept for sound analysis, to this concept was a need for a mechanical housing which is developed throughout the thesis.

Glossary

CAD – computer aided design

CCTV – closed circuit television

CNC – computer numerical control

CREO – CAD program

IP66/65 – waterproofness coding

1.2 Objectives

The main purpose is to develop the enclosure for a sound analysis concept. The parts should be developed according to product development processes and meet the requirements of the technical specification validated by performing tests. The product should be an indoor water resistance product.

The system involves an electronic analysis device developed by IPsense, the housing that was developed by the author at Lund University, Division of Machine, Design Faculty of Engineering and the Industrial Design School (IKDC).

1.3 Limitations

The research doesn't include individual interviews made in person, but focuses on an Internet survey and polls made in user groups. The participants in the user groups was not given an opportunity to comment on the results, that have emerged during the development process, since IPsense has chosen to keep the product concept confidential during the process of development.

The economic aspects are not included due to them not being borne in the company. Also, they would only suggest a rough estimate of variable costs since only prototypes was developed, no production ramp-up was made.

Regarding sound testing there was only time for one test having no further time to develop and perform another one made on a new prototype (as of the dish-design).

1.4 Chapter distribution

The chapters mainly have the following content:

Chapter 2

Contains the methodology basically following Ulrich & Eppinger product design development process but also incorporates Industrial Design Methods.

Chapter 3

Contains the theoretical parts relevant to this report. A basic overview is written of the Product Development Process.

Chapter 4

Involves an in depth study of the Product Concept Development Process: Market Analysis, Industrial- and mechanical design approach.

Chapter 5

Contains the Prototype Generation process involving component generation, prototyping, CAD and CNC-process as well as assembling of the parts.

Chapter 6

Contains the testing set up of the parts and results.

Chapter 7

Read the full discussion and reflection made throughout the project.

Chapter 8

This chapter involves a technical analysis of some details, including recommendations of future improvements.

Results

Read about the results found in the project and also an evaluation regarding project plan, “who has made what” and what the author has gained knowledge about during the project.

2 Methodology

This chapter describes the methods used in developing the product. The methods are related to data collection, methods within product development and evaluations tests.

2.1 Introduction

To gain knowledge in the field of sound analysis an online study was carried out on the internet also some articles written in the field was analyzed.

Membership of user groups with expert hands-on knowledge was set up to research the difficulties related to sound analysis.³

After the data was distilled and analyzed drawings for the product was made.

The method related to the mechanical project (development of a physical product) was a combination of Industrial Design and mechanical engineering methods⁴.

The product prototype is at first hand made in a workshop then digitalized in CAD and finally produced in a CNC-machine making a cutting edge β -prototype.

After the first prototyping was carried out, design aspects was discussed an evaluated, after final adjustments was made different tests were carried out.

2.2 Implementation of the thesis

The thesis degree is 30 credits or 20 week studies performed at the Mechanical Design Engineer program, Lund University, Sweden. See the main project plan in regards to the time distribution in the Gant chart below.

Activity		W6	W7	W8	W9	W10	W11	W12	W13	W14	W15	W16	W17	W18	W19	W20	W21	W22	W23	W24	W25	
Mission Statement	Idea presentation																					
Start up	Projectplanning																					
Identify needs	Need list																					
Brief	Target Segmentation																					
Target Specification	Benchmark																					
Idea Generation	Sketches, models																					
Concept Match	Screening, Scoring																					
α -prototype	Pre-test																					
β -prototype	CAD, CNC, Test																					
Report	Compiling																					

EXHIBIT 2-1 Gant planning chart for the Master Thesis.

³ According to the FBI, 50-75% of incidents related to Video Surveillance are non-alerted.

⁴ Product Design and Development by Ulrich & Eppinger is used as the base for systematic evaluations.

2.3 Methods used

The methods used:

- **Basic research**, searching the internet for empiric information regarding articles, statements, product development, pictures within video surveillance.
- **Brainstorming** is a group or individual creativity technique by which efforts are made to find a conclusion for a specific problem by gathering a list of ideas spontaneously contributed by its member(s).⁵
- **Meetings**, regular meetings with IPsense discussing the ideas and results from the working process, iteratively.
- **Product Design Processes**, the method described in Ulrich & Eppinger concerning chapter 4-8 and Industrial Design methods from IKDC, Lund.
- **Prototype generation**, Manual machining, CNC-machining
- **Tests**, sound (audio dead room), heat (processor on 100%), water (water jet)

⁵ Brainstorming is a useful quick creative process conducive to unusual ideas, quantity of ideas and criticism. After a session the volume was narrowed down by combining and improving the ideas.

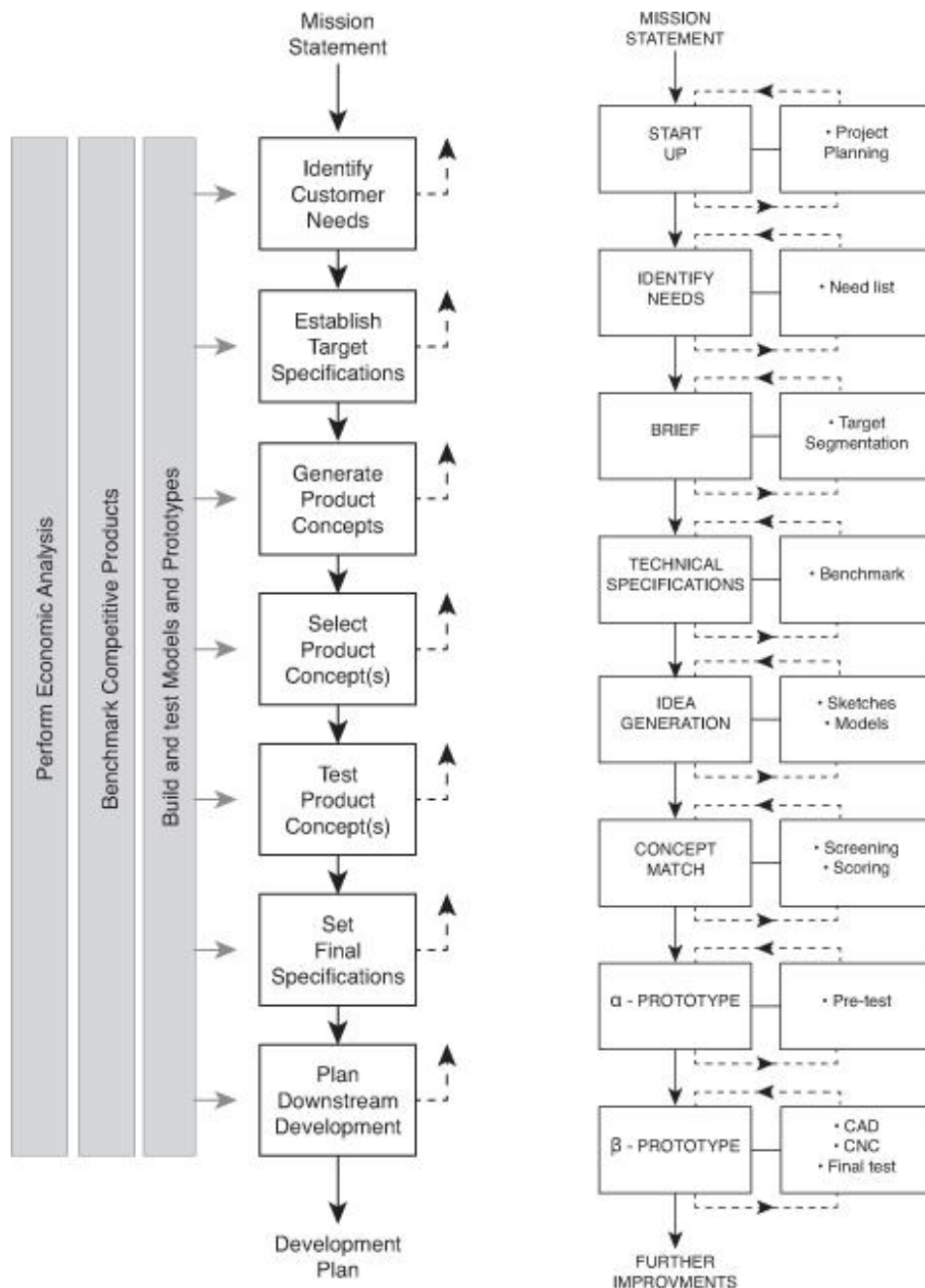

EXHIBIT 2-2 To the left a picture of the product development method by Ulrich & Eppinger vs. the method used for the Master Thesis. The process is iterative within each step and combines the Ulrich & Eppinger with methods from Industrial Design.

2.4 Prototype Development Process

The α -prototype was developed using manual drawings and sketches based on suggestions that emerged from the "Screening, Scoring"⁶ process. The drawings were the basis for the development of the α -prototype using the manual lathe and milling machines. A brainstorming session was carried out on design aspects for which detailed solutions were discussed. The β -prototype was then made in CREO 1.0 (CAD software) and post-processed in Autocad 2012 before imported to the CNC machine guiding system (Heidenhain). Both CNC milling and lathe machines was used.

The product was developed using CAD and CNC technologies to achieve:

- Optimal sound recording
- Modern and appealing design
- Suitable production methods

The product is produced to enable indoor usage, in office environments, or in industrial facilities.

2.5 Product Tests

One early idea was to test the audio recording capabilities in a room, an attempt to find out whether the design made in the housing cover gave any improvement to the performance. The test was not only to test the function of the housing but also to compare the sound recording with the microphone mounted in the top-lid compared to having it hanging in the air alone. To achieve this, a test was performed at Division of Structural Mechanics in the audio dead room. Test on the housing was also planned to perform regarding waterproofness, heating, ventilation and EMC.

The test objectives were to investigate the following:

- How would the top-lid design affect the sound recording capabilities?
- Could the enclosure withstand water jets rated at IP65/IP66?
- Is the enclosure made easy mounting on roof or wall?
- Is the design suitable for indoor mounting concerning color and shape?
- Could the enclosure withstand temperatures (0-50 degrees Celsius) without the electronics overheating?
- Could the enclosure withstand relative humidity (RH) of 15-85%?
- Which problems would additionally occur?
- What can be improved?

⁶ Concept generation and Concept selection described by Ulrich & Eppinger, ch. 6-7

2.6 Iterative Working Process

To obtain a suitable working process combining an Industrial Design as well as a Mechanical Design -approach the following different steps was planned:

1. Start up
 - a. Product information
 - b. Project planning
2. Identify needs
 - a. Research market needs
3. Brief
 - a. Analyze product characteristics
 - b. Produce: Mood Board, Sector Diagram, Target Analysis
4. Formulate requirements for the proposed solution
 - a. Compare the predetermined conditions against the researched needs
5. Produce various suggestions to the solution
 - a. Sketches
 - b. α -prototype
6. Match the ideas against need formulated and select possible solutions
 - a. Analysis using Ulrich & Eppinger, Product Development Process
7. Develop a final suggestion
 - a. Visualization
 - b. CAD, CREO 1.0
 - c. FEM-analysis
 - d. Rapid Prototyping
 - e. Tests
8. Make 1 final prototype
 - a. CNC post-processing
 - b. Production
 - c. Photography
9. Presentation
 - a. Rapport, printed
 - b. Before the examiner, visual presentation

3 Theoretical Basics of Product Development

This chapter describes the theories that the author has used to acquire a frame of reference in the subject. It has been limited to an overview of the PDP-process that form the essence to the thesis since the concept are wide in range. Some theory will also be found along the thesis.

Product Development – A basic overview

An important component to a successful product is the ability to identify a client's needs and quickly respond to these needs by producing the product at a low cost. The ability to achieve the economic objectives is not just about marketing; it is a product development problem involving many areas. A product is something that is sold to a customer from a company. Product development is a number of activities that begin in a vision about the market opportunity ending with the production, sale and delivery of the product.⁷

Product Development features for high performance

From an investor's point of view the product is successful if its equal a good product development process which results in a profit when it's sold. However, profit is often difficult to achieve fast and direct. The following five dimensions, relative to earnings are used to obtain an overview of the product development performance.

- 1. Product Quality**

How good the product has become following completion of the development process? Are the customer's needs met? Is it robust and reliable? Product quality is reflected in market share and the price the customers are willing to pay.

- 2. Product cost**

What is the manufacturing cost of the product? The costs include capital investment and tooling as well as the cost of each unit. Product cost determines how much profit is allocated to the company for a specified volume of sales and a specific sale price.

- 3. Development time**

How quickly did the company develop the product? Development time determines how quickly the company can cope up with technological developments and how quickly the company will recover its investment from the development process.

- 4. Development Cost**

How much money did the company invest in product development? Development costs are often a small part of the investment required to make a profit.

⁷ Introduction of the Product Development process by Ulrich and Eppinger

5. Development Capability

Has the company become better at developing future products as a result of the experience of a product development project? Development capacity is an asset that the company can use to develop products more efficiently and more economically in the future.

If these five criteria are met, along with high performance input it will probably be an economic success, but other criteria are also important. These criteria come mainly from the shareholders, the development team, other employees, and among those who produce the product. The development team can be very focused on producing a fantastic product. Producers of the product are more interested in whether the product can create more jobs. Both the producers and users of the product hold the development team accountable for a high standard, even if its efforts are not only linked to a high profit. Other people who have no connection to the company may have comments on the product if it has a manageable ecological use of resources which ensures minimum waste.⁸

The Design and development teams

Product development is a multidisciplinary activity that requires certain input from virtually all functions of a business. The following three functions usually have a central role in the product development process:

1. Marketing

Marketing functions conveys an interaction between the company and its customers. Marketing support often identifies product opportunities, customer needs and market segments. Marketing is also responsible for communication between the company and its customers, pricing, product launches and advertising for the product.

2. Design

Design features play a crucial role in defining the physical form of the product to meet customer needs. In this context it includes the design function: engineering design (mechanical, electrical, software, etc.) and industrial design (aesthetics, ergonomics and user interface).

3. Manufacturing:

The manufacture function is primarily responsible for the design and to provide production system to manufacture the product. Other functions often included: purchasing, distribution and installation, referred to as the supply chain

Few products are developed by a single individual, those included depends on the product characteristics and form a development team, often with a team leader who can be recruited from any of these areas within the company. Often there are two different compositions: core and extended team. Core Teams are often small and can

⁸ Characteristics of Successful Product Development by Ulrich and Eppinger

fit in a conference room while the extended team consists of everything from a dozen up to a thousand members.

The development of a new product often takes longer than people think. The truth is that very few products can be developed in less than a year, some take 3-5 years, others as long as 10 years. The cost of a product is roughly proportional to the number of people in the project and the time required implementing it. In addition to the staffing cost, tooling cost and sometimes also machines for production will be added. These costs are often higher than the rest of the budget but can be viewed as a fixed production cost.⁹

Common challenges within Product Development

To able to develop good products are very tough and requires structure and dedication, many companies have success in less than half the cases. This outlook is a daily reality for a product development team.

The following characteristics represent some of the challenges for the team:

- **Trade-offs:** For example an airplane can be made lighter but it means that it will be more expensive to produce. What makes this difficult is to identify, understand and implement such a balance to maximize the success of the product.
- **Dynamics:** Improved technology, customer's own preferences develop, competitors introduce new products and the macro economy is changing. Succeeding with a product when these parameters are constantly changing is a huge task.
- **Details:** The choice between using different parts such as screws, bolts, spacers etc. in a motor has an impact on very high economic values . Developing a product on a fairly simple level can require thousands of different decisions.
- **Time Pressure:** These issues could easily be manageable by itself, if you had unlimited time, however, decisions about product development happen quickly and without the full picture.
- **Economics:** To develop, manufacture and market a new product allocates large amounts of money. In order to make a buck, the product must be appealing to the customer but also relatively inexpensive to produce.

Product development will appeal to some people because it is a challenge but its reel attributes also contribute to its attractiveness:

- **Creation:** Product development starts with an idea and ends with a physical thing. When looking at the big picture regarding the individual performance it can be seen that the process contains a lot of creativity.
- **Satisfaction of societal and individual needs:** All products are made to meet any type of need. People who are interested in developing products always find environments in which they can develop products in.

⁹ Who designs and develops a product, Ulrich & Eppinger

-
- **Team diversity:** Successful development often requires different skills and talents. As a result, development teams usually include a variety of skills, experience, perspectives and personalities.
 - **Team Spirit:** Product development teams are usually a group of people who are highly motivated and cooperative. The team is in sync in order to focus their collective energy towards creating a product, often with good companionship as a result.¹⁰



EXHIBIT 3-1 The Product development process according to Ulrich & Eppinger. The diagram indicates the order in which the various integrated methods should be considered to perceive successful results.¹¹

Clarification of picture above:

Planning The product planning phase precedes the product development process.

Concept Development is the sequence of steps or activities performed throughout the project to conceive a suitable design that can commercialize a product using customer need analysis, benchmark, economic planning etc.

System-Level Design includes the definition of the product architecture decomposed into subsystems and components.

Detail Design describes the complete specification of the geometry (CAD), materials selected and production costs.

Testing and refinements involves the evaluation of the product in regards to the construction. The β -prototype is generally thoroughly tested among the customers in order to identify necessary engineering changes for the final product being produced.

Production ramp-up the production is made using the intended production system to train the staff in producing the product and evaluate if there are any remaining flaws to correct before gradually ramp-up to an ongoing production.

¹⁰ The Challenges of product Development by Ulrich & Eppinger

¹¹ The Product Development Process is a development method that is regarded in this thesis. The concept development also involves industrial design methods.

4 Product Concept Development

This section includes the company involved, product development concept, market need research, the industrial- and mechanical design approach. In addition, sound design and how the idea to the design evolved.

4.1 Product Specification – IPsense

This project has a client Mikael Jansson president of IPsense. The project specifications will therefore consist of his demands and wishes. IPsense are currently developing a new product which have the need for a industrial designed housing. The product is an electronics device which shall have a plastic or metal housing. The housing shall meet the following requirements:

1. The enclosure shall be rated according to IP66/IP65, which means that it has to be dust proof and withstand powerful water jets.
2. The enclosure shall allow easy wall mounting, which means that one professional shall be able to mount the end product to a wall on his/her own.
3. The enclosure shall be of neutral color and shape. The end product is targeted for a professional market.
4. The enclosure shall be able to hold the electronic component without overheating. The design shall withstand climatic conditions of temperatures ranging from 0 to 50 degrees Celsius and a relative humidity (RH) of 15-85 % (non-condensing).

4.2 Product Development Limitation

The product to be produced should operate in an indoor situation for both office and industrial settings. The production should be made possible in series of 1-10 pieces, which largely defines the type of manufacturing process to be selected. Regarding the cost and time limitations related to manufacturing the material was decided to be plastic. There was no budget set on the prototype, economic aspects are therefore not considered in this thesis.

4.3 The Market Need – Which is it?

One market to look into was the surveillance market since it is clearly an interesting one for the product to exist in, but others could also be considered such as environmental, transport and the industrial.

When you start looking at the surveillance market you will quickly conclude that the product that dominates right now is different variations of cameras. Partly from the previous model type CCTV who traditionally appears in many contexts, but also newer systems that are networked based (via IP-technology). What strikes one with clarity is that this approach to surveillance could appear a bit primitive. It seems to be based more on the need to calm the fears by recording the environment or looking at the events on-line, at least when it comes to incidents based on crimes.

This market has exploded in a short time which is clearly perceived when companies in the industry employ many people over a short period of time due to high demand. Thoughts that appear: whoever shall be monitoring and reporting incidents on a screen will be a person. Could humans ensure that this always happen? At the moment there are some software solutions that subsequently could be used to analyze the sequence of events, with various results I have learned. At the same time that we need to control our environment, based on our concerns, the paradox is growing of the reduced integrity because of surveillance. How should the market deal with this?

At home, in urban areas, on transportation vehicles, in every single environment that can accommodate people will soon have a camera set up. Right or wrong, it is extremely lucrative to create technological innovations in order to gain control of the fear that people and organizations seem to be suffering from. But even if so, will people really get the help they need by installing a camera? Does it lead to more incidents being reported, or is it becoming a self-fulfilling prophecy, with the result that more incidents occur because of this?

These are questions to ponder on and require its investigation; this project may help answer some of them. This thesis will show that there are ways to facilitate monitoring with additional technology, not only by using an “eye” but also the “ear”. Does this mean that we will hear what people will be saying? No, this is not at all the case. But by doing a sound analysis on a location we may collect information that could help us make decisions about whether it is required to report an incident or not.

4.3.1 Identifying customer needs

As a first step a brainstorming session was started together with IPsense exploring what kind of angle the questions should have. The nature of the questions became more about collecting information about existing technology, the difficulties that occur within environmental analysis and some cost-related aspects were included. The goal was to verify that the initial parameters were in line with IPsense new technology.

Secondly it was decided to establish a membership on LinkedIn.com. The objective was to create a dialogue with expert user groups to explore the experience they have

of environmental surveillance and find out which areas have a potential for improvement, sense cost aspects and look for ergonomic issues.

By creating multiple choice questions, using a survey function that the website offered (so called polls), a statistical basis was established and comments captured. Besides this a questionnaire with similar questions was put on monkeysurvey.com. (A survey website including analysis functions). This was done with the intention to get people to participate in the poll then having the choice to, via link, participate

The survey was designed aiming to identify customer needs of today's problems and possibilities within environmental analysis researching how to support the issues. Then compare the results towards the knowledge that IPsense had, after that start developing the product.

Need list analysis

The results of market research rendered a dataset including the research via monkeysurvey.com and through expert user groups on linkedin.com. All data were gathered in one spreadsheet this was divided into the columns: "type of data", "needs", "ranking" and "points". All comments were then interpreted to a need. When mutually comparing all subgroups, they were ranked by issuing a numeric value to each need. The ranking was made 1-5, whereas 1 gave 5 points and 5 gave 1 point. Then the data were sorted after "data type", which created data clusters (data arrays of the same type), from each data grouping a sum could be calculated. The groupings were then sorted once again in relation to highest and lowest value of the points given. The data group with the highest value was moved top of the list and so on. This formed the basis for the project "need list".

The collected data now contained the information related to the overall product concept. Since the thesis project involves the design of the cover, the redundant dataset will not be reported in detail. The information has been used by IPsense for internal analysis of the concept level of innovation which shows that no such concept exists on the market.

The different data types analyzed from the need list were:

- Product function
- Product Performance
- Software
- Economics
- Training

To complete the need list, the technical specification developed by IPsense was added. Now the list consisted both of needs that came up regarding video surveillance in general including those that form the basis for designing the housing. Hence, these have been ranked in the top compared to other needs on the list. Since the project was to design the housing, only the data related to product design have been used as empirical base regarding the product development process (see Chapter 4.5.2 Concept Selection Process).

Analyzing the needs that are related to the housing (called the "Product Design") reveals that the key feature is the "modularity" together with "waterproofness", "temperature and moisture resistant", "EMC isolated" and "sabotage protected". Further down on the list: "easy mounted enclosure", "neutral design" and "accurate microphone placement."

Ranking of topics

After the need list was compiled, a reconciliation with IPsense was done to settle the list before ranking of topics, nothing was added. By copying "type of data" and add them to a new spreadsheet called "ranking of topics" it was easier to get an overview of how the needs should be prioritized when developing the product functionality. This was done by adding 1-3 stars in front of each need. To be certain that this was correctly prioritized a reconciliation with IPsense where made again where it was decided that "easy mounting" and "neutral design" should be prioritized doing the product more attractive to purchasers, from 3 stars to 2.

Ranking of topics

Priority	Topics
	1. Product design
***	Modular design
***	Waterproofness (Swe IP65/IP66)
***	Temperature & humid proof
***	EMC compability
***	Tamper proof
**	Easy mounting
**	Neutral design
*	Enable accurate microphone placement
Points:	35

4.4 Industrial Design approach

The view of how a product should be developed from an industrial design perspective varies. In this case, the product is both technically functional and must meet certain criteria to be able to operate in an indoor environment, both for office type rooms and together with industrial applications. One option could be to design a product for each environment, initially this has been discussed, but what has emerged from the meetings with IPsense was to develop a model that works in both environments. Possibly, some simplifications could be made for the indoor model that not need reach the IP (water resistance) requirements when put in a production context. (See product development delimitations 4.2).

In order to meet the product requirements that have been decided upon from IPsense, there are a number of different factors to consider when developing the product. In essence, the designer has to create a concept design that allows for the requirements to be met. In more detail, this means that various mechanical sub functions (see in 4.5 how the solutions on mechanics emerges) will meet solutions for ergonomics, aesthetics, user interface and manufacturing capabilities. This is often referred to as the Industrial Design concept, a design concept created from the point when customer needs and product limitations have been clarified.

There are different ways to create a powerful design concept. Generally, the method involves rapid drawings which act as an inexpensive medium when presenting the ideas followed by concept generation, testing, system-level design and refinement. (See chapter 3).

Drawings are the key features of the design process. In the early drawing stage the drawings are not to anyone except the designer, a way of thinking out loud. This creative part can sometimes be perceived as somewhat mysterious, from simple data presented by the client, the designer will respond after a reasonable period of time with the first draft of a design concept. It may seem if it was plucked out of the air somehow. But in reality the process is not as magical as it seems but involves clear steps in a design process.

In any case there is something mysterious about the human ability to propose a design for a new artifact. The ability to design comes partly from the ability to visualize inboard, in "the mind's eye"¹² but maybe it depends even more on being able to visualize and see how things fit into the surroundings, ie, external visualization.

In the following chapters I will describe the various steps that I consider important and have used when it comes to deciding the design concept after some brief sketches has been made. In addition those and the customer needs analysis, this involves the mood board, sector charts, target segmentations and briefings.

¹² Reasoning about the design generation p. 9, Nigel Cross, Engineering Design Methods

4.4.1 Mood Board

When using a product, the way it should be used and in the right environment, the product will convey a sense to the user that the designer has come up with due the creative process. The sense is linked both to the aesthetics and functions but also to how the product is communicating and what kind of message it is carrying. For example, contours, materials, surfaces and colors have a clear connection, more subtle expressions will be found when analyzing the product semantics. (See Chapter 3).

A mood board is a collage of materials (such as images, texts, colors, photos, samples of material) that describe the mood or feel of a place or a design. Mainly designers but also other skills using mood boards in developing the concept of communicating different styles and characteristics to others involved in the process. A mood board is useful as a reference and communication support in many different professions¹³.

The mood board developed for this project is a compilation of situation images, product images, colors and textures taken from different contexts that the concept could be used in. In the process of finding these images, which simultaneously inspires, an inner picture will slowly be formed in relation to how the concept might look and work. The objective in this case is to start communicating a general sense of the product in the context of the concept notion that IPsense presented. The next step will be to develop a sector diagram and analyze where the product concept could be placed in the marketplace compared to other similar products.



EXHIBIT 4-1 Mood Board showing the sense for the product.

¹³ Wikipedia definition of Mood Board as being an important tool in the “touch & feel” process.

4.4.2 Sector Diagram

In mathematics is a matrix a rectangular diagram of numbers or other quantities. In this case the same system is applied to analyze a product concept based on degree of opposite properties defined on x and y axis. The properties of the x-axis go from stand alone to integrated products. On the y-axis it is set from intelligent to an unintelligent product. The choice of properties is motivated by the product concept to be developed, since it will be an intelligent product in an integrated system.

After the market survey was conducted online to find out about other surveillance concepts it appears that there exists other intelligent and integrated system. One observation that was made was that these systems primarily are designed for military purposes. Most other monitoring systems may contain some intelligence when they are networked based and connected with some kind of computer system. But there are still systems that are analogue with the cameras connected to a recordable DVD.

In order to compare the different concepts, the images are positioned in the matrixes where they supposedly would fit.

Sectordiagram Outdoor Video Surveillance



EXHIBIT 4-2 Sector diagram showing different surveillance systems. The green ellipse is where the sound analyzing concept could be placed.

4.4.3 Target Group Segmentation

The segmentation means to divide the market into groups with common needs, they could be expected to react the same way on the business offer and is supposed to have enough money to buy the product.

On a deeper level it is common to analyze demographic data, however these are rough instrument. If they should be used as a basis for defining the target groups there will be pitfalls to watch out for. Anyone who buys a product need not be the person using it.

The target group segmentation picture is roughly divided in industry segments based on which IPsense initially think they can turn to with an offer. The industries are the following: transport, government, consumers and industry.

Transport industry is rapidly increasing in many countries with great need of surveillance. For example, one could imagine that the airline industry is in need of increasing the safety for passengers and cabin crew. With new technology it is possible to improve the quality of information from the cabin to the cockpit, so that the pilots could react quicker and more accurately make a decision about an incident.

The state controls many functions in society such as school. At a school many incidents occurs daily and the problems with fights and shootings seem to increase in different places around the world. A playground is an open area with a strong need for monitoring in order to prevent bullying, fights and keep track of people not belonging there.

Consumer market consists of many different places where monitoring is necessary. Among the most important would be to suggest the banks and exchange offices since they are handling banknotes, but also shops of all kind. To date, all banks have a monitoring system based on a video surveillance system usually located behind the cashier, also alarm buttons are mounted beneath the counter. However, it still remains a challenge to catch the thief since the camera system isn't intelligent enough to analyze what happens especially if the person trying to steal is not wearing a face cover at least as it appears. (In Sweden banks could legally use sound analyzing systems).

The manufacturing industry has during long had problems with downtime. Already in the 70s scientists where researching on new technology that could prevent system failure or guide the engineer to make the right decision from the control room. Today there are some camera systems developed for the oil industry that can respond to incidents. But for the manufacturing industry there is still a need to manage machines automatically preventing downtime. There is a need for systems to be designed to stop a machine in time without destroying the material it processes. In steel factories, CNC lathe and milling situations such systems would increase the product quality and save money due to downtime.

Targetgroup segmentation

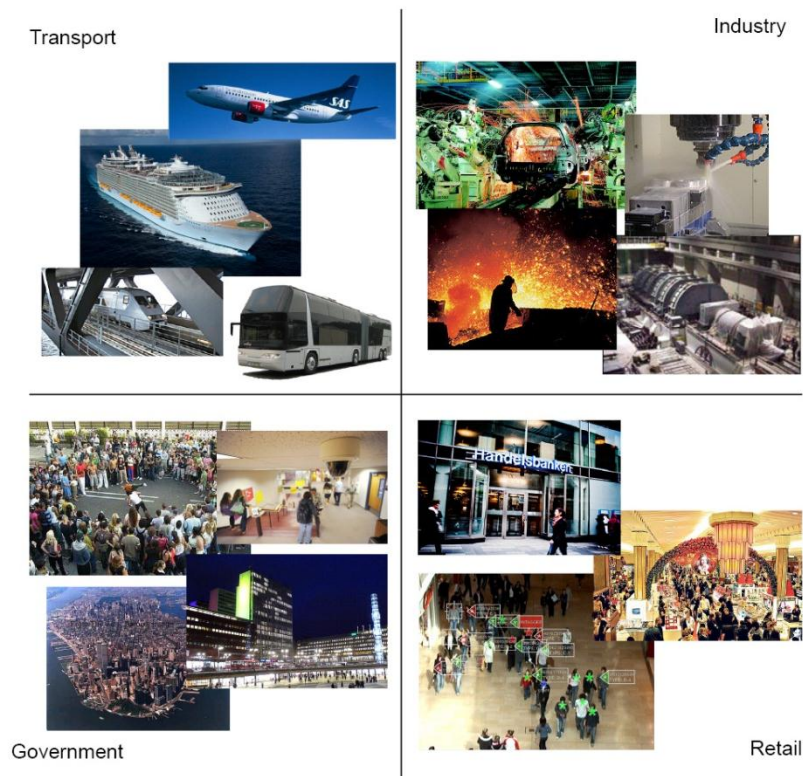

EXHIBIT 4-3 Target group segmentation showing pictures of different industries where sound analysis could be helpful.

4.4.4 Design Brief

The Design brief is an aid to the design and product development process. It shall describe the user's preferences and needs, market demands and expectations, the company's opportunities for new and creative solutions. It shouldn't propose a solution to the task. Writing a design brief helps the client himself has to think through the project from a holistic perspective, which in turn increases the chances of high quality work. The design brief shall summarize the requirement for the project and define goals and success criteria without specifying a particular (design) solution.

A brief could contain the following elements¹⁴:

- Identify what the new product should be
- Describe the product's basic function
- See the product from the user perspective
- Describe the user and the product personality

¹⁴ Design Brief content, KTH, Stockholm. Compared to IKDC, Lund the content shows similarities.

-
- Describe the characteristics that determine the value of the perceived
 - Describe what the product reflect and contributes to the company's image
 - System design: Is the product linked to a product system
 - What elements will determine the technical quality level
 - Tell a good story, create a slogan
 - Creating good environmental qualities and makes them visible
 - Concentrate the brief significant heterogeneity

The design brief that were developed includes the points above. The economic aspect is omitted, primarily because the product concept is completely new to the market. The document was written before the market research was made, at a later stage, this information can be added if necessary. (See Chapter 4.4).

IPsense Brief

Project: Sound Analysis

Which is the basic function of the product?

- Analyze sound from the environment

How will the product be?

- Helpful, paginal, effective, discreet, serious, free from maintenance

How does the user perceive the product?

- Simple, odd, easy to understand, innovative

The personality of the user?

- Technical/engineering type, high demands, picky, educated

The personality of the product?

- Reliable, discrete, modest

How is the experience of the product?

- Fantastic, "at last", unique, "must have"

Is the product a part of a bigger system?

- Yes, a camera surveillance system

What is its level of technical quality?

- Medium to advanced level

Are there any environmental factors that are important:

- Yes, waterproofness, UV-resistant, enduring temperature, tamper proof, biodegradable

How much could the product cost for the customer?

- Yet not decided

4.4.5 Function Analysis

After the brief is written it is also appropriate to make a functional analysis to establish the functions and how they are structured. This identifies the product main function and secondary functions. From the Industrial Design perspective this is focused on primary and secondary functions. Compared to mechanical design approach which involves a deeper analysis on the main functions, sub-functions, support-functions and how they interact with each other using a process tree.

Whether it is needed to do one function analysis from each design approach could be discussed, in this product development process it is chosen to start from the Industrial Design point of view due to the product's level of complexity. If the product concept would involve more than one system or product group it is recommendable to define a process tree. The result of a functional analysis is a thorough understanding of the new product's function and sub-functions. Based on the input values of these parameters, new parts and components can be developed. In the process these features should be obtained and be measurable.

Regarding the product enclosure developed for IPsense the function analysis resulted in the following content:

Main function (primary)

- Online, capture and analyze sound from the environment

Other than that (secondary)

- Having a design that blends into the environment
- Easy to operate
- Easy to install

4.5 Mechanical Design Approach

The design process could be described in different ways. Most approaches describe simply a number of sequentially organized activities that typically emerge when designing a product. Other models try to describe a better and more structured process with clear dividing lines between different activities. As a designer it is, from my point of view, essential that right from the start consider which approach should be used. In this case an Industrial Design process combined with a process that evaluates the mechanics could be appropriate. There are certainly other ways to perform a design evaluation, here selected theorems of Ulrich & Eppinger and Cross is used combined with the Industrial design process taught at IKDC, Lund.

4.5.1 Concept Generation

A product concept is an approximate description of technology, working principles and design of the product. A product concept is usually not only expressed as a sketch, but also includes rough three-dimensional models and a sample of how the

texture will look like. The concept generation phase is not such an expensive process and could be performed relatively quick compared to the rest of the development process according to Ulrich & Eppinger¹⁵. In order to achieve a good result it is useful to generate various structured design concepts. Later in the process they will be compared against each other by using a numerical system. Doing this will avoid financial pitfalls as well as ineffective integration of promising side solutions.

A concept generation process normally goes through 4-5 different phases. The first step is to structure the problems and sub-problems. In this project IPsense had predefined the technical specifications which formed the basis for the problems to be solved (see the Product Specification section 4.1). After this was done, an external research of expert users were performed which identified the type of needs existing on the market. Internally, an inventory of information was made doing interviews with IPsense, ensuring facts regarding the technology that was used. Internet were searched for articles and patents on the subject of sound analysis, after that a benchmark was made. (Similar products on the market were not found apart from a patent to a similar microphone solution used by Louroe).

Exploring sub-problems

By systematically going through the main problems (eg. technical specification) suggested solutions were made regarding to the sub-problems which mainly were related to the integration of the electronic devices:

- Ventilation of the housing
 - o Gore membrane IP68
- Water resistant solution of cable attachment
 - o Fixation using O-ring
- Placement of holes for mounting of the housing
 - o Holes inside housing
- Design to assembly the beagle-board inside
 - o Elevated heel with screw fixings
- Securing the assembly of the microphone
 - o MMA epoxy glue and conductive sliver epoxy
- Mounting of the microphone
 - o Threaded tube incl. special designed nuts
- Water resistant protection of the microphone
 - o Gore membrane IP68
- Sealing of various holes
 - o Track for O-ring

The solutions were presented and evaluated together with IPsense (iterative working process). It was then determined that the problems had to be solved in such a way that the design of the housing would receive an integrated look. Practically this meant that the solutions to the problems would not be visible from the outside, if possible.

¹⁵ The Concept Generation process is described by Ulrich & Eppinger being used when building a new product or when to develop a new solution concept for an existing product.

Concept Selection Process

Earlier in the product concept development process the customer needs were identified. The selection of concept was based on the needs as well as other criteria, a comparison of the strengths and weaknesses of these concepts was made based on the criteria related to product design aspects. A selection of some concepts was then further investigated, developed and refined.

Before the numerical evaluation of concepts was performed a number of sketches were made presenting different design concepts of the housing for IPsense (iterative working process). During this process, solutions were made to the sub-problems in relation to the design aspects.

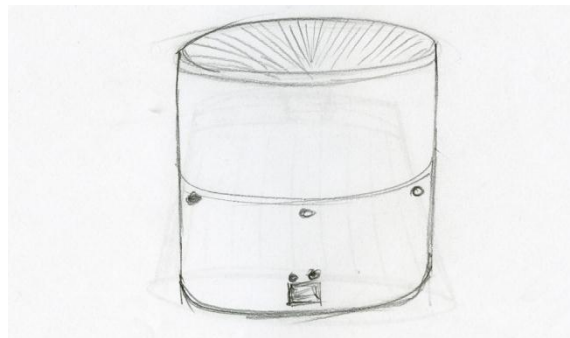

EXHIBIT 4-4 Tube with fixed parabolic design, Concept A

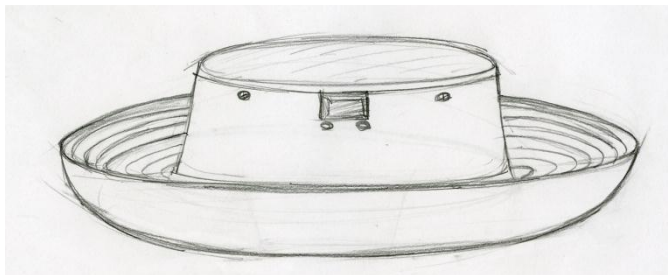

EXHIBIT 4-5 Plate design inverted, Concept B

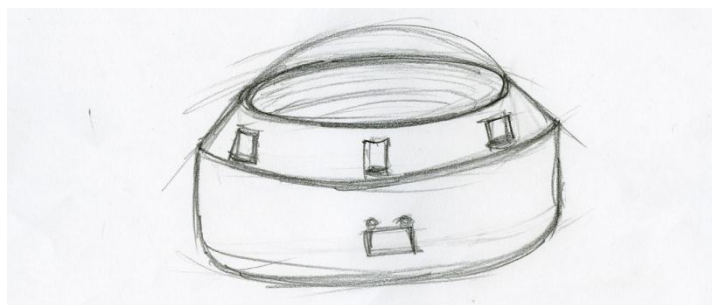

EXHIBIT 4-6 Fixed parabolic design, Concept C

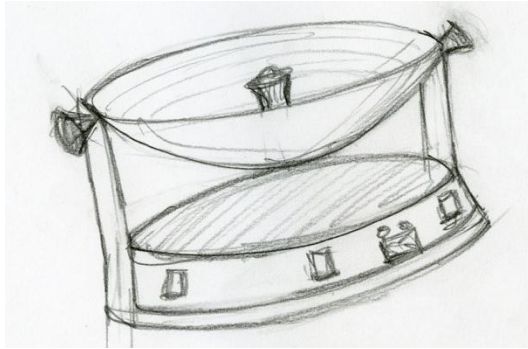

EXHIBIT 4-7 Adjustable parabolic design, Concept D

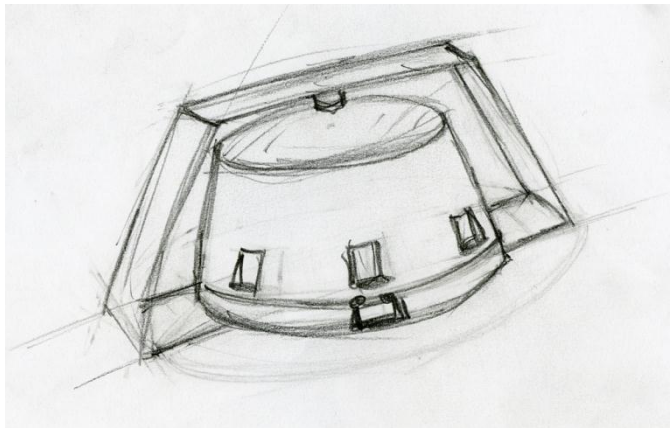

EXHIBIT 4-8 Fixed patent design, Concept E

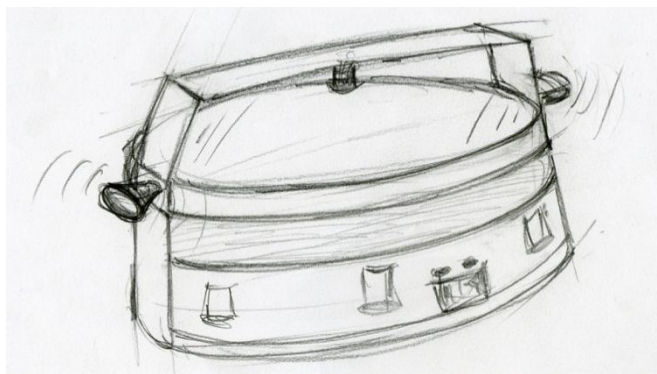

EXHIBIT 4-9 Adjustable patent design, Concept F

4.5.2 Concept Screening

In order to quickly narrow down the concept and identify which are most suitable for the product concept, the information is prepared in a Concept Screening Matrix (see Ulrich & Eppinger). The column called "selection criteria" is input values taken from the "rank of topics" matrix, in this case those related to "Product Design" are evaluated. (Note that many designers in advance have a vague idea, gut feeling, which concept is best, the method is therefore useful when the number of "selection criteria" is increasing).

The principle is to evaluate the "selection criteria" for each concepts using 0, +, and -, these are later on summed and a net score is obtained. The next step is looking at the possibility to combine the concepts with the same net score in order to do improvements.

The first step is therefore to collect all the sketches and give each drawing a letter and a name which then are placed into the matrix in the order A to Z. Thereafter, all concepts rates of 0, + and - in relation to how well the "selection criteria" match the a reference concept. (In this case a ceiling mounted microphone from Louroe). The next step is to rank the concepts from worst to best. This is done by summing respectively 0, + and - in the "sum" column. A net score can be calculated and concepts will then be gradually ranked from worst to best.

Combine and improve concepts is the next step in the process to crystallize the winning one. The following issues should be considered:

- Is there generally a good concept that has been downgraded because of a bad feature?
- Could a minor improvement perfect the general concept still retaining the distinction from other concepts?
- Are there two concepts that could be combined to preserve better quality while eliminating the bad ones?

Any new combinations are added into the matrix and ranked again. Then one or more concepts are selected for further refinement and analysis. In this case, the concepts A, B and C received the highest net score and were analyzed for any possible combining. Since the concepts had such a different design appearance a combination didn't add any improvement for the final result and were therefore not combined. Instead they were selected for a better differentiation, Concept Scoring.

IP SENSE	Concept Screening						
	A	B	C	D	E	F	REF
Selection criteria	Tube w. parabolic design	Plate design inverted	Fixed parabolic design	Adjustable parabolic design	Fixed patented design	Adjustable patented design	Louroe Ceiling mounted
Modular Design	+	-	+	-	-	-	0
Waterproofness	0	+	0	-	-	-	0
Temperature/humid proof	0	0	0	-	-	-	0
EMC-isolated	0	0	0	+	+	+	0
Tamper proof	0	+	0	0	0	0	0
Easy mounting	-	-	0	-	0	-	0
Neutral design	0	+	-	-	-	-	0
Accurate microfon placement	+	+	+	+	+	+	0
Sum +'s	2	4	2	2	2	2	0
Sum 0's	5	2	5	1	1	0	8
Sum -'s	1	2	1	5	4	5	0
Net Score	1	2	1	-3	-2	-3	0
Rank	2	1	2	5	4	5	3
Continue?	YES	YES	YES	NO	NO	NO	NO

EXHIBIT 4-4 The Concept screening matrix showing concept A, B and C having been ranked for further investigation. The concepts were rated against a reference project which net score is 0.

4.5.3 Concept Scoring

The next step in the process of evaluating the concepts is to use the Concept Scoring matrix. This way the result will get more refined and a final winner (or two) will be nominated. During this process the selection criteria could be broken down in sub-criteria to enlarge the level of details. This is not always necessary to do at all and is up to the designer to decide. It is possible to use secondary or tertiary needs from the customer need list to bring in more details to the concept.

To be able to rate the concepts a new column will be introduced in the matrix called “weight”, which works as the overall weight for each selection criteria. On the concept level each will also have a column called “rating” and a column called “weighted score” for the result to be calculated in.

After that a finer scale for rating is used (1-5) which will be performed on each level of selection criteria for each concept in relation to the reference concept:

<u>Relative Performance</u>	<u>Rating</u>
Much worse than reference	1
Worse than reference	2
Same as reference	3
Better than reference	4
<u>Much better than reference</u>	<u>5</u>

When the ratings has been entered on each concept the result of the “weighted score” will be calculated, which is similar to the total score.

$$S_j = \sum_{i=1}^n r_{ij} w_i^{16}$$

where

r_{ij} = raw rating of concept j for the i th criterion

w_i = weighting for i th criterion

n = number of criteria

S_j = total score for concept j

To appoint a winner each concept is given a rank according to weighted score. With the purpose of optimizing the concepts there could be combinations of concepts that will work better than the original. Finally it is the top ranked concept that will win after have performed a final evaluation by conduction a sensitivity analysis. When doing this one can vary the input data to achieve a different weighted score while comparing the importance of the “selection criteria”.

While doing the product enclosure development for IPsense the Concept Scoring was rated against a reference concept. A difficult issue was to sort out the spread between the highest and lowest weight among the “selection criteria”. After the Concept Screening session was ready a meeting with IPsense was held to decide upon which features really was most important and which was not. In this concept it seemed that the product modularity functionality was rated the highest and the tamper proof feature was rated the lowest. The final result was to select a solution based on a housing solution that could work as the base and having the possibility to change the “lid” which could be made with different shapes adapted for different environments.

¹⁶ Ulrich & Eppinger, ch. 7, p. 136

Main reason for the “fix parabolic design” concept to win was the convenient size converting it into a different shape serving different purposes. The “plate design inverted” concept could hypothetically be more sensitive to the material it was mounted on not being able to receive a satisfying resolution of the frequencies. The concept had uncertainties due to the design and was therefore put aside. Also “the tube with parabolic design” was probably a suitable design in terms of collecting a wide range of frequencies but could be too big as of the housing furthermore difficult to design with modularity. The concept was therefore also put aside after it was discussed and reflected on together with IPsense.

IP SENSE	Weight	Concept Scoring						REF MODEL	
		A. Tube w. parabolic design		B. Plate design inverted		C. Fixed parabolic design		Rating	Weighted score
Selection criteria		Rating	Weighted score	Rating	Weighted score	Rating	Weighted score	Rating	Weighted score
Modular Design	20%	4	0,8	3	0,6	5	1	3	0,6
Waterproofness	15%	3	0,45	4	0,6	4	0,6	1	0,15
Temperature/humid proof	10%	4	0,4	4	0,4	4	0,4	3	0,3
EMC-isolated	12%	4	0,48	3	0,36	3	0,36	3	0,36
Tamper proof	5%	2	0,1	3	0,15	3	0,15	2	0,1
Easy mounting	7%	3	0,21	3	0,21	3	0,21	3	0,21
Neutral design	13%	3	0,39	4	0,52	3	0,39	3	0,39
Accurate microfon placem	18%	4	0,72	4	0,72	5	0,9	3	0,54
	100%								
Total score			3,55		3,56		4,01		2,65
Rank			3		2		1		4
Continue?			NO		NO		YES		NO

EXHIBIT 4-5 The method of Concept Scoring uses a weighted score calculation to compare the selection criteria’s.

4.5.4 Modular Design Concept

Modular design, or "modularity in design" is an approach that subdivides a system into smaller parts (modules) that can be independently created and then used in different systems to drive multiple functionalities. A modular system can be characterized by the following:

- (1) Functional partitioning into discrete scalable, reusable modules consisting of isolated, self-contained functional elements
- (2) Rigorous use of well-defined modular interfaces, including object-oriented descriptions of module functionality
- (3) Ease of change to achieve technology transparency and, to the extent possible, make use of industry standards for key interfaces.

Besides reduction in cost (due to lesser customization, and less learning time), and flexibility in design, modularity offers other benefits such as augmentation (adding new solution by merely plugging in a new module), and exclusion.¹⁷

The winning concept was analyzed and from a mechanical point of view the modularity was decided to comprise a thread connecting the housing with the lid. This way the functions of the housing, including carrying the beagle-board were separated from the lid with its functions.

A high pitched thread was a possible solution connecting the two parts without:

- Sacrificing waterproofness due to an untight fit
- Adding any limitations to the design aspects
- Creating an ergonomic problem when serviced

Other solutions was also evaluated and discussed with IPsense, such as having the lid pressed on as on a cake can or having a plate as a framework mounting the housing on top. These solutions could possibly be easier to manufacture and cheaper as well but was dismissed not giving confidence in handling issues related to waterproofness.

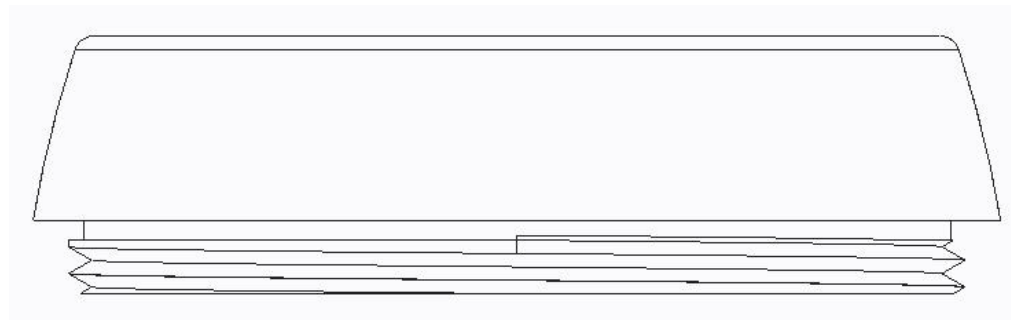

EXHIBIT 4-6 Picture showing top-lid with a high pitched thread.

4.6 Sound Design

The result from the benchmark showed not many typical design aspects of products related to capture or detect frequencies within sound. The typical sound detection device is the spy microphone which has a deep dish design that has the ability to focus in on the source without distraction from ambient sound. A satellite dish showed the same shape in order to receive the highest possible reception from a satellite. The closest a product that was found being able to detect the sound in an overall indoor environment was device with a microphone in the middle.

¹⁷ Definition of modular design according to Wikipedia



EXHIBIT 4-7 Left picture showing the spy microphone, right picture a ceiling mounted microphone from Louroe for interviews recordings, courtroom etc.

4.6.1 Sound Design – Limitations

The goal was to solve the problem to able to collect the sound frequencies in an indoor-room-type-of-environment being a priority to the thesis.

4.6.2 Sound Design – Inspiration

The scientific theory of gathering frequencies of sound is based on the same theorem as of light. Naturally there are elements in the nature that need light like trees and flowers. Analyzing the design of those elements, being specialized in the photosynthesis as a leaf, shows that they don't entirely consist of a flat surface. There are bulbs and curves showing that the spectrum of light will be reflected on these patterns and bounce around in different angles for some reason.

Another natural design feature is the human ear, as an auditory system. Consisting of the earlobe outside and the auditory channel inside which mediates the sound to the inside organs via self-resonance. When analyzing the earlobe it became clear that there were similarities to the leaf having curvatures and often an elliptical shape on the sides.

Some facts about the outer ear design

“The outer ear does help get sound (and imposes filtering), but the ear canal is also very important.

In some animals with mobile pinnae (like the horse), each pinna can be aimed independently to better receive the sound. For these animals, the pinnae help localize the direction of the sound source. Human beings localize sound within the central nervous system, by comparing arrival-time differences and loudness from each ear, in brain circuits that are connected to both ears. This process is commonly referred to as EPS, or Echo Positioning System.

The complex geometry of ridges on the inner surface of some mammalian ears helps to sharply focus echolocation signals, and any sound produced by the prey. These ridges can be regarded as the acoustic equivalent of a Fresnel lens.¹⁸

The above facts states that the shape of the ear on some animals is related to the effect of sensing the direction of the sound. Also small structures in the outer ear working as a Fresnel lens have the same principle as when focusing the light in a lighthouse bulb or prism. In order to get a large aperture and a short focal length compared to a conventional bulky lens design, the mass and volume was significantly reduced with this design. The Fresnel lens then gets much thinner, larger, and flatter, and captures more oblique light from a light source, thus allowing lighthouses to be visible over much greater distances.



EXHIBIT 4-8 Picture of the Fresnel lens showing the surface structure of the glass that are able to focus the light significantly.

“The efficiency for a satellite dish efficiency, with respect to depth, can be simplified saying that a smaller (shallow) satellite provides better gain than a deep dish, while providing a deep dish better insulation against external noise (eg microwave ovens, mobile broadband, etc).¹⁹”

4.6.3 Sound Concept – Evaluation

The following concepts to microphone placement were analyzed before designing the surface in which the microphone should be placed:

- Louroe Electronics, Verifact A, Ceiling Mount device
- Louroe Electronics, Verifact E, Outdoor an moist conditions

¹⁸ http://en.wikipedia.org/wiki/File:Anatomy_of_the_Human_Ear.svg

¹⁹ Satellite dish: <http://peterkristiansson.se/parabol.html>

-
- Louroe Electronics, Verifact K, background Noise
 - Patent of microphone placement

The Verifact K microphone shows some evidence that the microphone placement, in relation to the surface it was mounted on, has been specially designed in order to make it more sensitive. The other two models, which basically consists of a housing for the electronics with the microphone placed on one side, shows that the sound bonuses on a flat surface.

The microphone on the Verifact K model is a dynamic one with omni-directional pattern. The pattern is designed so that the sound is focused to better be picked-up from the front than from the side.



EXHIBIT 4-9 Picture of Verifact K which is especially designed for areas with excessive background noise or where the ambient sound level is high

The patent (U.S. Patent 4,361,736) shows that if a small condenser microphone is placed above a flat surface it will make the sound waves bounce back to the microphone having the sound pressure gradient enhanced. The concept makes it possible to have microphone placed on any surface not being damped by the surrounding wall or ceiling.



EXHIBIT 4-10 The microphone detects changes in this pressure zone, rather than the conventional method of detecting changes in the surrounding air pressure (i.e. sound waves).

4.6.4 Sound Dish Design – Integration of microphone

The different types of products (chapter 4.5.3.3) was analyzed and discussed with IPsense finding a suitable design for the microphone placement. Some sketches were made looking for a solution that both would have a design to the surface, hopefully enhancing the sound and that was aesthetically appealing at the same time. It was

discussed that in order to achieve a sufficient level of quality feel for the product the look and feel had to be solid and possibly curved somehow compared to a normal housing, normally a square box.

The shape of the housing was decided to be round, having analyzed other ceiling and wall mounted devices at the school of IKDC this was generally the shape of the housings that was used (chapter 4.5.1.2). A square, triangular or a polygon shape didn't fit the purpose for the concept and was dismissed. The gut feel imposed that a round shape of the housing would enable the desired design for the microphone placement.

Since the lid was made in CAD it was possible to decide on the dish opening angle and the rounding of the edges. The idea was to create a flat surfaced design in the middle with a shallow opening angle. The reason for this was that the microphone fittings were going to be placed in the middle of the dish, flush to the surface. Also, a deeper dish design would possibly shut out too much sound waves. In a meeting with my supervisors it was discussed whether this solution would have a focal point as a satellite dish as well.

Equation for distance to focal point:

$$F = \frac{D^2}{16d}$$

F = focal point

D = diameter of dish

d = depth of dish

$$F = \frac{0,125512^2}{16 * 0,0135} = 0,072931 \sim 72.9 \text{ mm}$$

The result shows that a focal point would appear approximately 73 mm above the center of the dish. A discussing was held whether the microphone would rather be placed in front of the dish. This alternative was dismissed because of the mechanics involved becoming too fragile for the indoor product also being too difficult to make waterproof.

The final design was then inspired by the human ear having the microphone device mounted on the inside of the housing in a tube fitting. Tests would later on show whether the design could enhance the sound pressure in the middle of the dish compared to a flat surface.



EXHIBIT 4-11 The top-lid showing a dish-like design with a middle hole for the microphone.

5 Product Generation

This chapter contains the process of building the first and second prototype. It involves construction of each part and selection of associated components. First prototype is handmade in lathe and milling machines. After evaluation and refinement the model is made in CAD, prepared for CNC-machines, after that a second prototype is made in the automated process.

5.1 Parts and Components

Having gone through the concept selection process in chapter 4, it was together with IPsense decided to develop the concept called “fixed parabolic design”. The concept was modular in the way that the lid could be replaced by another lid-design, suitable for the environment where the device was mounted. The housing was also made waterproof (IP66/65) which involved specially selected fittings to obtain the function, such as Gore[®]-membrane, silicon cable feed through and O-rings.

The construction involved different ways of integrating the parts and electrical components, with a design not showing those elements from the outside when mounted, as well as meeting the requirements of the technical specification. (See chapter 4.1).

5.1.1 Mechanical Parts

The following parts constructed for the α -prototype was:

3D electronic circuit housing:

- Housing in plastic (bottom and top)

Microphone enclosure:

- Tube in aluminum, embedment of the microphone
- Nut in steel, fastening the tube
- Top-ring in aluminum, holding the tube with O-ring fittings
- Safety net in copper, net covering the microphone

5.1.2 Electrical Parts

The electronics of the device are custom made to meet the demands on technical functionality as well as usability. The electronics for the product comprises a PCB (Printed Circuit Board) and electronic circuits mounted on the PCB. PCB have eight layers of circuit paths that link the different electronic components to each other. PCB made by a method which is a substrativ (U.S. substrative) method, which means using a surface coated with conductive material such as copper as a starting point. In order to create orbits the copper is removed around the intended path. The most common method when doing this is known as photoengraving. When the PCB has the form of a laminated printed circuit boards (eight layers) then a solder mask is placed around the soldering pads on which the electronic component will be mounted. The solder pads are then covered with solder paste.

The electronic components are mounted with SMT (Surface Mount Technology). By using a pick and place machine, components are placed on PCB board so that the components interfaces are located on the solder pads. Then, after the card is heated in a soldering oven, heat causes the solder paste on the solder pads to melt and thereby create a leading connection between the electronic component and circuit board plumb.

Electronics

The electronic hardware of the product is based around an MPU (Micro Processor Unit) from TI (Texas Instruments). MPU is an ARM Cortex A8 with ARMv7 architecture, MPU running at speeds up to 1GHz.

Microphone

The specially designed microphone used for the product consists of an electret microphone with a frequency range of 20-20000 Hz.

5.2 Material Selection

Developing a product that both could be used indoor and outdoor suggested that there were a couple of different materials to choose from. The outdoor version was not part of the thesis but since it was a concept for a future differentiated product program, it was initially discussed. The indoor model was decided to be made in a plastic material in line with other products having a similar installation on a wall or a ceiling.

5.2.1 The Plastic Material Pyramid

A thermoplastic is either partially crystalline or amorphous (U.S. semi cristal line, amorphous). An amorphous plastic is transparent and a partially crystalline plastic which are "milky", non-transparent.

High temperature plastics have high thermal and mechanical strength, better creep resistance at higher temperature range (excluding fluorine plastics) and are self-extinguishing.

Structural Plastics are the most common material for processing in the automotive industry, electrical industry, transport and household applications because they often provide good wear resistance.

Standard plastics are plastics that volume is used most. The durability is not as high as for high temperature plastics but it is not expected when produced.²⁰

Picture of material pyramid, Text: The pyramid shows the plastics that have higher quality compared to standard and engineering plastics.

Plastic Characteristics

The plastic material needed had to work in a temperature range from 0-50°C and be neutral white, this excludes all the amorphous which have a clear color. According to the pyramid it would suggest a plastic called PE or PP in the lower temperature range. POM was also discussed from the mid temp. range as well as PEEK from the high temp. range.

PE, Polyethylene is a partially crystalline thermoplastic polymer that belongs to the olefin plastic (synthetic fiber made from a polyolefin) which is a paraffinic hydrocarbon with a smooth, slightly oily surface.

Main characteristics:

- Excellent impact strength over a wide temperature range
- Low water absorption
- Good electrical properties
- Low coefficient of friction
- Good chemical resistance
- Difficult to glue
- Mechanical and electrical characteristics are maintained even in water
- Easy to weld (PE 300)
- Large thermal expansion

Applications: The food industry, pipe, plumbing, container, products requiring low friction coefficient, insulation materials, etc.

PP, polypropylene has similar characteristics PE

POM, polioxymetylen is a partially crystalline, thermoplastic engineering polymer with high stiffness and toughness, excellent process ability and versatile use.

Main characteristics:

- Very good electrical insulating
- Stable and rigid
 - Tough

²⁰ The Pyramid Material is a description of the various plastic in relation to the temperature and crystallinity.

-
- Easily machined, able to buff
 - Low coefficient of friction
 - Difficult to glue
 - Good weld ability
 - Resistant to hot water, some dilute acids, detergents and many solvents

Applications: Machine and automotive manufacturing, transport and feed technology, electrical engineering, precision engineering, household appliances, food and medical technology.

PEEK, Polyetheretherketon is partially crystalline, thermoplastic polymer for high requirements often used in cogwheels.

Main characteristics:

- Withstands high thermal-mechanical loading
- Very tough
- Low coefficient of friction
- Creep Strength
- Wear resistant
- Excellent chemical resistance
- Electrically insulating
- Hydrolysis, even in the superheated steam
- Easily machined
- High resistance to gamma radiation
- Shape permanence

Applications: Machine and automotive manufacturing, nuclear and vacuum technology, transport and feed technology, textile, packaging and paper machinery, electronics, precision engineering, food and medical engineering, chemical engineering, aviation and space flight.

5.2.2 Plastic Evaluation

The PE and PP was too fat and oily in the surface creating long ductile chips when it was machined, also the temperature range could be too low if the processor in the circuit board was overheated. PEEK was an interesting plastic due to its mechanical characteristics, it was very strong and tough but for this application it would seem unnecessary. Also, it only comes in beige color which would suggest that it probably be more suitable for hidden components rather than visible. The choice made using POM were mainly because it was easily machined, tough, stable and being white colored. Other important features were the electrical insulation capability and its resistance to solvents and hot water which in this case was a primary feature if used in an industrial situation.

5.2.3 Steel parts

The parts made for the microphone had to be made in steel to create enough conductivity.

The material selected for this was aluminum due to easy machining and conductivity. A casket also had to be made to protect the membrane on the microphone using a metal net of some kind. Available at the time was a stainless steel net and one made in copper. Copper was more suitable because it was softer and therefore easier to form.

5.3 Production process

It was discussed with IPsense which method was going to be used to produce the products after they were prototyped. The idea was to try and use the same production method as for the first series that would be produced. To begin with, a small series of products was preferable to produce using a method that wouldn't demand expensive tooling.

The following prototype methods were evaluated:

- Rapid prototyping
- Resin casting
- CNC – automated process

5.3.1 Rapid Prototyping

The use of additive manufacturing takes virtual designs from computer aided design (CAD) or animation modeling software, transforms them into thin, virtual, horizontal cross-sections and then creates successive layers until the model is complete. It is a WYSIWYG process where the virtual model and the physical model are almost identical.

The 3D-method available was digital light processing (DLP). A vat of liquid polymer is exposed to light from a DLP projector under safelight conditions. The exposed liquid polymer hardens. The build plate then moves down in small increments and the liquid polymer is again exposed to light. The process repeats until the model is built. The liquid polymer is then drained from the vat, leaving the solid model.²¹

This method doesn't involve any preparation of digital material other than exporting a STL-file to the system. The time to produce the two pieces would be estimated to 10 hours. The downside would be that the preferred color of the plastic is difficult to achieve without having the parts spray painted. The cost of the pieces would also be quite expensive.

²¹ Different 3D-printing methods are presented on wikipedia showing the general principles.



EXHIBIT 5-1 Picture showing Mojo 3D printer.

5.3.2 Resin casting

This is a method of plastic casting where a mold is filled with a liquid synthetic resin, which then hardens. The synthetic resin for such processes is a monomer for making a plastic thermosetting polymer. During the setting process, the liquid monomer polymerizes into the polymer, thereby hardening into a solid.

A flexible mold can be made of latex rubber, room temperature vulcanized silicone rubber or other similar materials at relatively low cost, but can only be used for a limited number of castings.

The simplest method is gravity casting where the resin is poured into the mold and pulled down into all the parts by gravity. When the two part resin is mixed air bubbles tend to be introduced into the liquid which can be removed in a vacuum chamber.

Each unit requires some amount of hands-on labor, making the final cost per unit produced fairly high. This is in contrast to injection molding where the initial cost of creating the metal mold is higher, but the mold can be used to produce a much higher number of units, resulting in a lower cost per unit.²²

²² The casting resin method shows that many smaller components has been appropriated for the production of collectible toys, models and figures, as well as small-scale jewelry production.



EXHIBIT 5-2 Picture showing rubber mold for resins casting

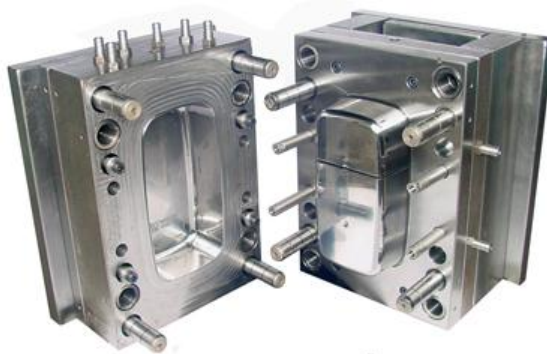

EXHIBIT 5-3 Picture showing injection mould for plastic injection.

5.3.3 CNC – automated process

Numerical control (NC) refers to the automation of machine tools that are operated by abstractly programmed commands encoded on a storage medium, as opposed to controlled manually via hand wheels or levers, or mechanically automated via cams alone.

In modern CNC systems, end-to-end component design is highly automated using computer-aided design (CAD) and computer-aided manufacturing (CAM) programs. The programs produce a computer file that is interpreted to extract the commands needed to operate a particular machine via a postprocessor, and then loaded into the CNC machines for production. Since any particular component might require the use of a number of different tools-drills, saws, etc., modern machines often combine multiple tools which could be automatically changed using a tool changer that holds up to 20-30 different tools.²³

²³ CNC is a modern method to reproduce a product designed in CAD.

A complex series of steps needed to produce any part is highly automated and produces a part that closely matches the original CAD design. The preparation of the CAD file, having a product made the first time is time consuming. The need for special programming knowledge is highly recommended in the post process. The cost of the first product would therefore be rather high due the time needed to prepare the files for the control program. No extra hand-labor will be needed to the product when finished, the finish is very high.

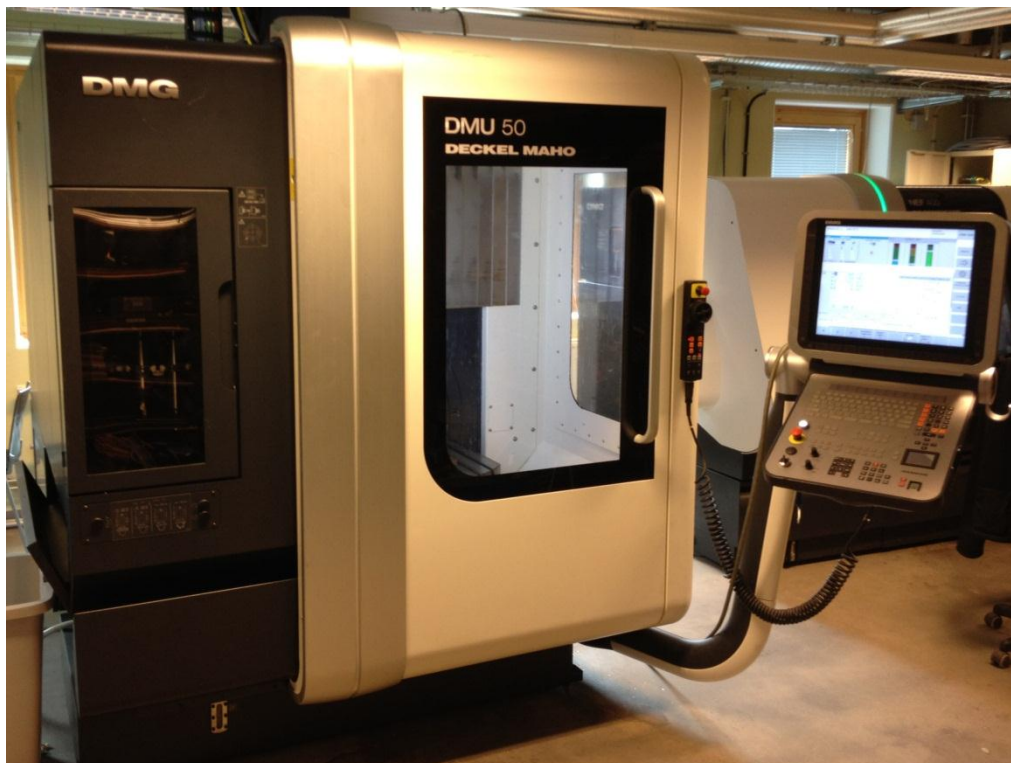

EXHIBIT 5-4 Picture showing CNC-mill used for the β -prototype.

5.3.4 Production Evaluation

When evaluating the prototyping methods that could be used for a small series production it was suggested that 3D-printing became too expensive, not being able to control the color and quality of the plastic that was preferred. The plastic resin method could be used for a small scale production. But since the mold only could handle a small number of castings, the method was deemed to be unreliable and time consuming. Using a plastic injection method would be way too expensive at this stage but could preferably work when the production should be ramped-up.

Using the CNC would be an easy controlled method, yet initially time consuming regarding programming issues. Also the choice of material and its color would be possible to control compared to the other production methods. Even though the first prototype would be rather expensive the pricing of a following small series would

significantly drop for each unit related to the time of production, labor (CNC-operator) and material costs. The choice was then made together with IPsense using the CNC-process as the production process for both second prototype and for a small series production later on.

5.4 Prototyping

Prototyping is a process where there is made a tested single-unit of the product in this project for IPsense. A prototype is often used as part of the product design process to allow engineers and designers the ability to explore design alternatives and make improvements before the sharp production starts. Prototypes are often complicated to make since new designs often have unexpected problems, there is also a great uncertainty as to whether a new design will actually do what is desired.

Before the CNC processed β -prototype could be made a first α -prototype was made using manual machines such as lathe, mills, drill, then it was spray painted. The material used was an easy machined plastic called cibitol.

5.4.1 α -prototype Design – Handmade

From the hand sketches made when screening the concepts in chapter 4.5.1 combined with the technical specification from IPsense an idea for the design emerged to be tested. Some additional drawings were made by hand to be able to size-up the product 1:1.

The general idea was to create a solution similar to a can having a lid screwed on top, making a big thread on the inside having the pieces connected to each other. The bottom was going to be made out of a solid piece of cibitol plastic having the inside material removed using a lathe, saving an inside “floor”. It was discussed with an external supplier whether a hollow tube in any way would be better. This option was dismissed because the tube was significantly more expensive than a solid piece. Furthermore, there had to be a bottom attached somehow which also demanded machining to be fitted and mounted. This solution would therefore be more expensive taking in account that the material loss would be greater.

Since the color of the product was decided to be white it would be spray painted afterwards.

In conclusion, making the housing from a solid piece would both simplify the solutions regarding waterproofness not needing to attach a “floor” but also increase the feeling of a high end quality product.

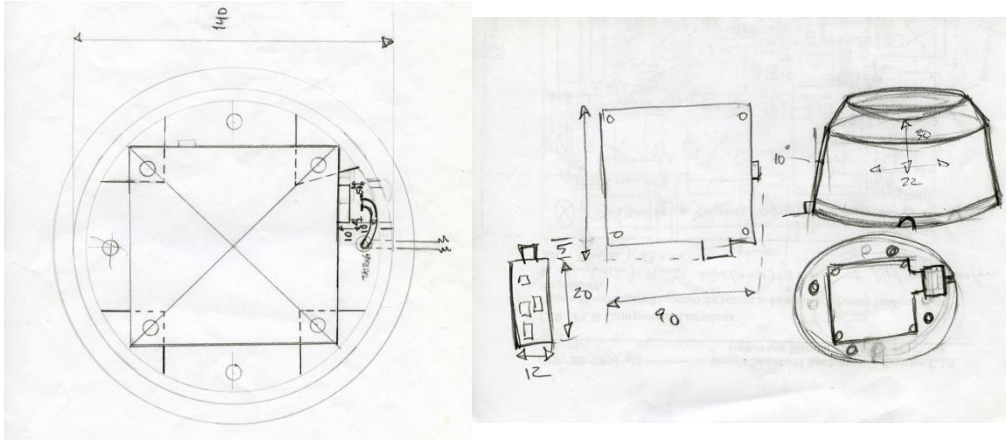

EXHIBIT 5-5 Picture showing example of constructions drawings used for the prototype made by hand.

Bottom housing

Regarding the bottom housing the main issue was to have the beagle-board to fit inside leaving enough room for the external cables to be connected on it. The first solution making the cable fitting waterproof was to use an O-ring from the inside. The holes for installing the housing on a wall were also made from the inside as well as the thread connecting the lid. The outside of the housing was angled 2° . Two holes for locking screws were milled for on the side of the housing when the lid was screwed on. Finally, to be able to fine-cut the back of the housing a tool was made attached in the lathe, the housing was then screwed onto it before being processed.



EXHIBIT 5-6 Picture of hollowing out the bottom housing.

Top lid

The lid was a solid piece of cibadol plastic that was machined in the lathe. It had to be lathed from both sides. From one side the design of the dish was made incl. the angle of (5°) of the lid, then turned and attached from the other side, the outside thread was made, incl. the O-ring seat. Finally the hole for the microphone tubing including hole for flush mounted aluminum top-ring was made incl. seats for O-ring.



EXHIBIT 5-7 Picture of top lid drilled for microphone tube.

Microphone EMC embedment – aluminum tubing

When designing the built in microphone it was decided to use a 16 mm aluminum tube having the microphone embedded inside of it. To have the tube fixated in the lid a nut was going to be used on the inside and a threaded top-ring on the outside, flush to the lid. Therefore, the tube had to be threaded on the outside both starting from the top and from the bottom making a fine M16x1 thread.

It was discussed with IPsense whether a pre-fabricated microphone was going to be used to simplify the prototype. But, because of various readjustments having to be made regarding the electronic circuit this option was dismissed being too expensive made especially for the prototype.

The microphone including its electronic circuit was encapsuled using MMA-epoxy inside the aluminum tube having the tube work as a faraday cage. (This is an enclosure formed by a conducting material or by a mesh of such material. The enclosure blocks external static and non-static electric fields.²⁴)

²⁴ Faraday cages are named after the English scientist Michael Faraday, who invented them in 1836.

To be able to optimize the grounding of the tube, conductive silver epoxy glue was also used to embed the microphone in (placed at the orifice of the tube).

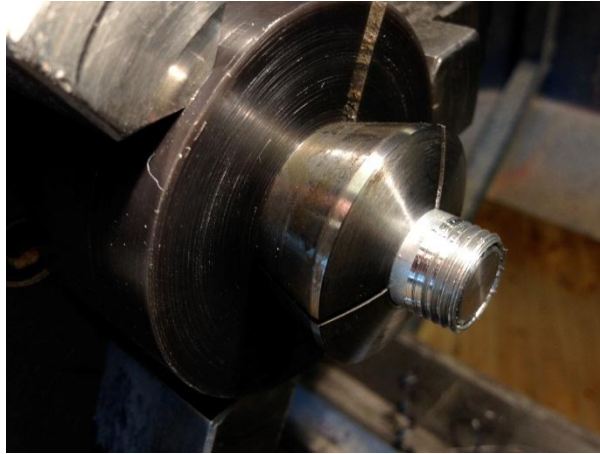

EXHIBIT 5-8 Picture of tube for microphone being threaded.

Steel nut (fastening the tube on the inside)

A standard pre-fabricated fine threaded M16x1 nut was used for the microphone tube. Since it was too thick it was divided in two halves.



EXHIBIT 5-9 Picture of nut cut in two half in the lathe.

Aluminum top-ring (attaching the tube incl. O-ring fittings)

To achieve an integrated design having the microphone tube mounted flush in the outside lid, a top-ring in aluminum was made in the lathe. The ring both served as the top fastening point for the microphone incl. fittings for the O-ring (material: EPDM 70 shore) as well as carrier of the copper net protection.



EXHIBIT 5-10 Picture showing top-ring cut off.

Copper net (microphone-membrane protection)

From the inside of the aluminum top-ring a net in copper was placed. The net was designed with a convex bulge. To achieve this feature a tool for the hydraulic press was made in the CNC-lathe. The tool had a bulge surface and a flat support surface of 1 mm around the bulge to face the aluminum ring from the inside. Another tool, a hole punch was also made to able to punch the copper net in the correct diameter.

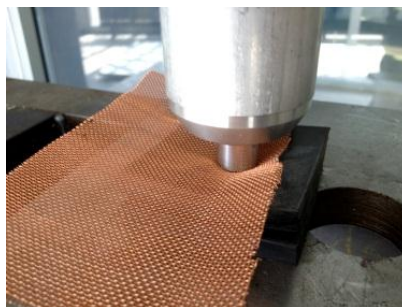

EXHIBIT 5-11 Picture showing hole puncher and the copper net that was made.

5.4.2 α -prototype Design – Evaluation

Looking at the sizing of the housing including lid it was found that it was a bit too high. The angled sides had a fine meeting but could be looked over again finding a better flow to the lines. The top-lid had a nice curved dish surface but the top edge needed to be rounded. Looking inside the housing it was decided with IPsense that the four mounting holes for wall- or ceiling installation was going to be put outside the box somehow, not having to remove the lid when it was going to be installed.

The thread was too small (pitch 2.5) having the lid to be turned too many turns before closing in on the O-ring seat. The lid was too heavy therefore material needed to be removed from the inside. The beagle-board required a solution for the attachment of the circuit inside the housing, not being able to move. The solution made for making the network cable waterproof had to be changed since the O-ring seat didn't seem tight enough. Due to humidity that could build up inside of the housing there had to be made a waterproof ventilation hole, in addition a membrane had to be used in the orifice of the microphone tubing making it waterproof.

Summary of the refinements to be made for the CNC β -prototype:

- Sizing down the overall height
- Redesign the installation holes
- Sizing up the thread
- Beagle-board mounting device
- Improve the fitting for the cable feed through
- Install a ventilation membrane on the housing
- Install a waterproof membrane to the microphone



EXHIBIT 5-12 Picture showing the finished α -prototype.

5.4.3 β -prototype Design – CAD

The β -prototype was from the start made in a CAD program, some sketches looking on details where made separately, the program used was CREO 1.0 (ProEngineer). The goal was to produce the β -prototype using CNC-machines, both lathe and mill, eventually having the files imported in the guiding program (Heidenhain).

At first the bottom housing was made in CAD making the improvements to α -prototype (described below). A main rough design was made using the “revolve” function, from that point on then processing the part to its final stage. The thread was made using “helical sweep” to receive a suitable pitch and placement together with the O-ring top seating.

Secondly the top lid was mainly also made using “revolve” and “helical sweep” for the thread.

Thirdly the aluminum parts were made using the “extrude” function. The outside thread for the tube was standard fine M16 as well as the inside for the top-ring.

Remaining standard parts, like O-rings etc. were imported from a part database or received via files from the distributors.

Finally an assembly file was made in CREO putting all parts together making some adjustment for O-rings to fit. Other than that the prototype was ready for CNC-processing. (The process of transferring the parts from CREO to the Heidenhain guiding program is described in 5.4.4)



EXHIBIT 5-13 Picture showing all parts included in the housing.

A re design of the outline on the β -prototype housing, before producing it in the CNC, was discussed with my supervisors when finished in CREO. A profile analysis was made to find an outline that would show a better flow in between bottom and top. The outline curvature was then finalized in .asm involving:

- Redesign of the housing outline (bottom and top-lid)
- Rounding the top lid edge

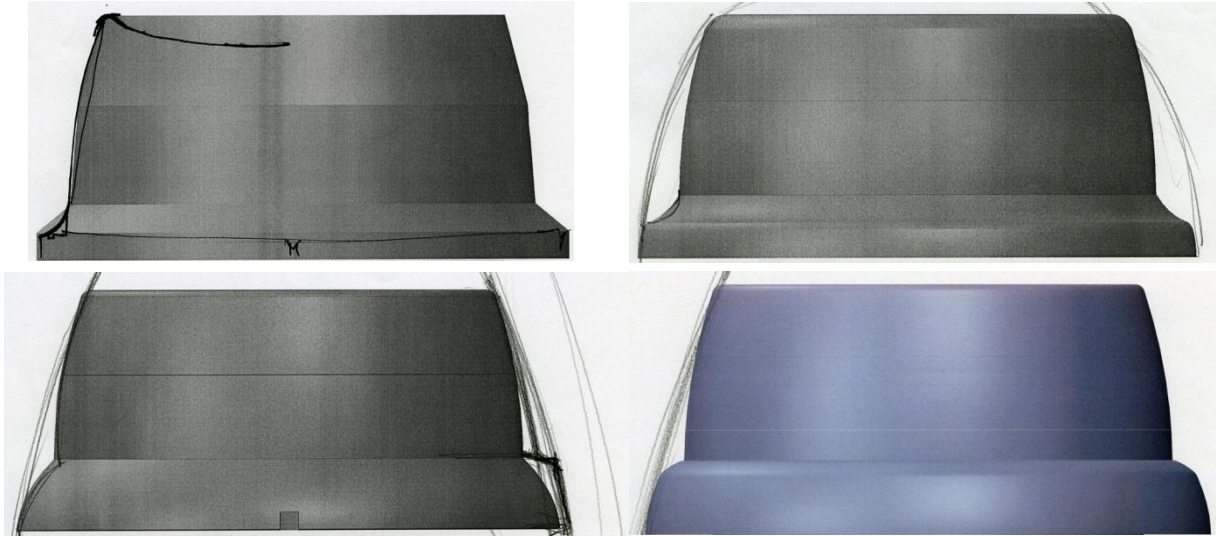

EXHIBIT 5-14 Picture of profile analysis showing top edges being rounded, the outline was curved and the bottom ring adjusted to achieve better flow in the design.

5.4.4 Improvements for β -prototype

The following was improved for the β -prototype:

- Housing dimensions
- Installation holes
- Thread pitch
- Electronic circuit attachment
- Cable feed through
- Ventilation hole
- Microphone membrane sealing

Housing dimension

The total height was lowered about 10 mm compared to α -prototype which got the housing to be more compact and neat.

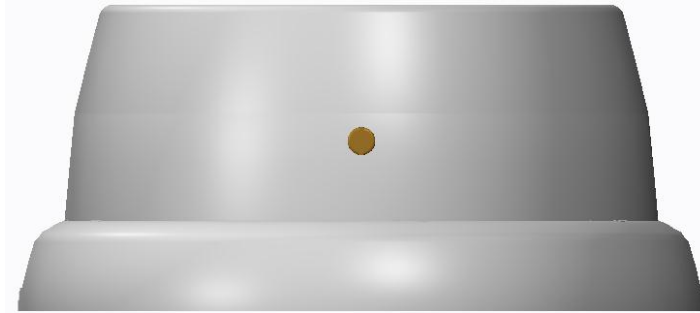

EXHIBIT 5-15 Picture of finished profile from the side.

Installation holes

The installation holes were changed from being placed on the inside to the outside of the housing. The “revolve”- sketch of the bottom was changed adding a “lip” to the side making the diameter in total 18 mm larger at the bottom. In the lip, the four installation holes were placed equally spread. Having the holes visible would be a problem for the device to be tamper proof. Therefore a ring was designed to cover the holes after installation.

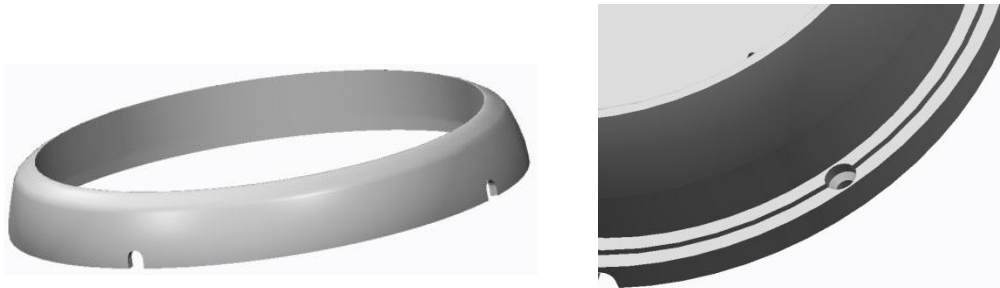

EXHIBIT 5-16 Picture of installation holes on outside bottom lip and the ring covering them.

Thread pitch

The thread of the pitch was changed from 2,5 to 4,0 having the lid only to be turned 2 turns when it was closed. This was made with “helical sweep” and had to be tested in the .asm file a couple of times before it was working. The space for the O-ring (material: EPDM 70 shore) seat had to receive the proper distance assuming that the friction would make it tight enough.

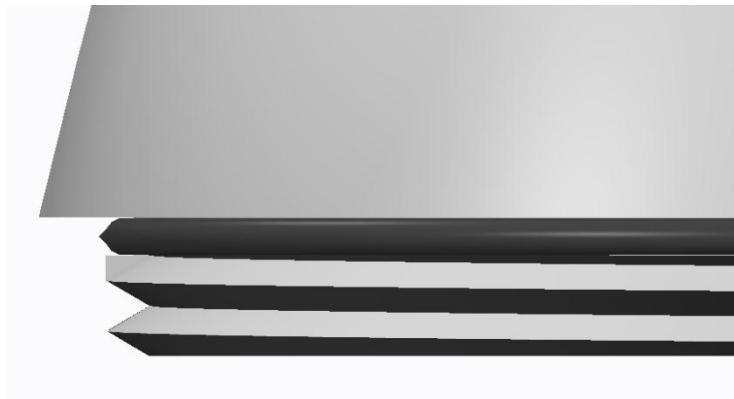

EXHIBIT 5-17 Picture of thread including O-ring on top-lid.

Electronic circuit attachment

Finding a suitable solution for the electronics to be fastened could do the inside “floor” elevated creating a heel for it to rest on. Then either using screws to have is fastened with on or a snap function. Based on the possibility that the device could be mounted upside down in a ceiling, the circuit would rather be fastened with a snap function. This would also make it safer when assembling the product not having to use a screwdriver close to the circuit with the risk of slipping and destroying the circuit.

The elevated “heels” that was made inside, on the “floor”, consisted of four squared pins with a snap “head” on the top. To be able to make the top-head a special milling tool had to be acquired and was adjusted to the correct size. The circuit had four holes drilled in it which was used to work with the snap-function.

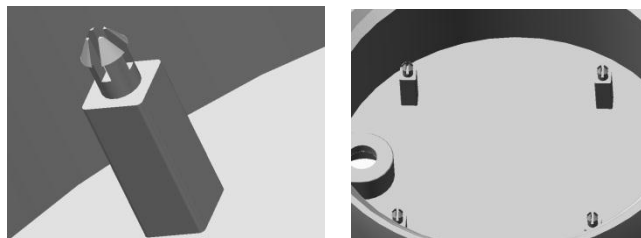

EXHIBIT 5-18 Picture of guide pin using snap-on head for electronic circuit attachment.

Cable feed through

The network cable feed through had to be both tamper proof and waterproof. A system called RUTASEAL[®] was used being heat-, weather- and chemical resistant. “The product is SEMKO approved up to IP67. RUTASEAL is produced in EPDM and Chloroprene in both PG and metric versions”.²⁵ Once the cable is inserted it will penetrate a membrane making the hole water resistance. Test samples were ordered from RUTAB.

The function was achieved by designing an elevating “heel” on the inside of the housing floor. The RUTASEAL[®] was then snapped in the “heel” through a hole made for its diameter. To have the cable come out on the top backside a chamfer was designed in the bottom surface. (The ring designed to cover the installation holes also had a chamfer for the cable to escape from).

Furthermore, the “lip” designed around the housing has a chamfer in it. This will allow the cover-ring (having a heel inside) to gently press on the cable making the cable tamper proof when “clicked” in place.

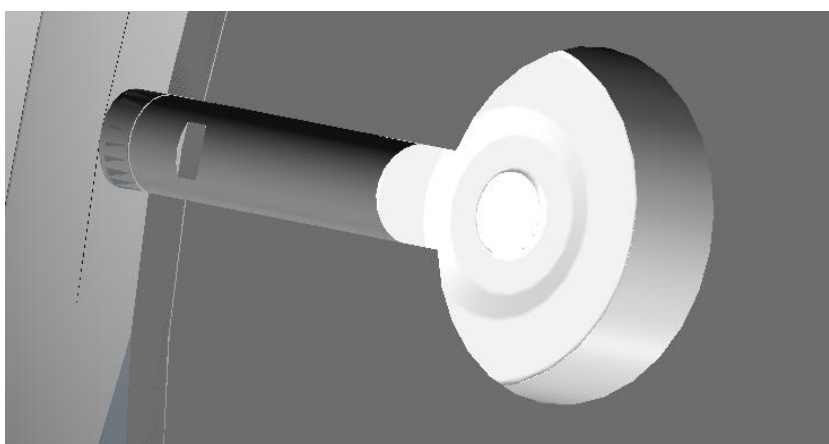

EXHIBIT 5-19 Picture of network cable feed through seen from bottom side including RUTASEAL[®] sealing.

Ventilation hole

The housing had to have a water resistance ventilation hole to vent out air if moisture was created on the inside through condensation. This was designed with same integrated principle as for the cable feed through, an elevated “heel” was made 90 degrees from the other one. There was also chamfer made both in the bottom and on the ring for the air to be vented out when mounted on a flat surface.

²⁵ http://www.rutab.se/egna_produkter/rutaseal_rutaseal_light_1

To obtain the function a product with a semipermeable membrane had to be used, both having the ability able to vent out humidity simultaneously being waterproof. The component is called “screw in vents” made by Gore®.

It has a plastic housing in Polyamide (PA6) with a ePTFE membrane inside and an outer thread of M12x1 including an O-ring. IP68 approved.

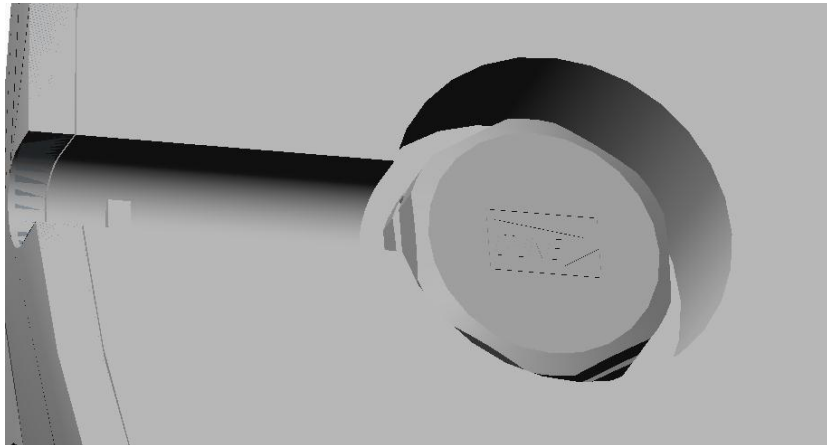

EXHIBIT 5-20 Picture of ventilation hole on bottom side using a Gore® Screw-in vent membrane.

Microphone membrane sealing

The microphone unit placed inside the tube also had to be water resistance. This was obtained by using an adhesive membrane that was attached in the orifice of the tube. The membrane was a product made by Gore® called “adhesive vents”. The circular membrane (oleophobic = physical property of a molecule that is repelled from oil) had an adhesive edge of GA3006 silicone.

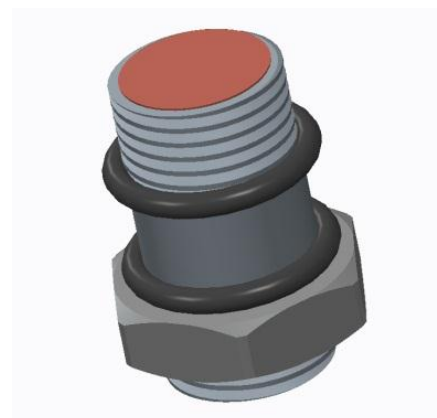

EXHIBIT 5-21 Picture of the microphone tubing including Gore® membrane on top, O-rings and bottom nut.

5.4.5 CAD – post processing

After the files were ready in CREO they had to be converted to the Heidenhain guiding systems to be used in the CNC-machines. Drawings incl. dimensions of the parts were made for the CNC-operator to work from. Both the lathe and the milling machine had different setups and was somewhat different in the programming sequences. The conversion from the drawings was mainly made manually by programming the guiding system using standard functions for making a hole, leveling out a surface etc.

The curvatures made to the side of the housing required both parts (bottom and top lid) to be assembled before they were machined in the lathe, resulting in one runtime of the curve. To be able to use the curvatures and rounding properly, a finalized conversion of these had to be made via Autocad 2012. At first an empty .drw-file was created via the .prt-file in CREO. After completing the settings, (scale, view and display style) of the .drw-file, it was exported to .dxf-format, settings: polylines. Then the .dxf-file was opened in Autocad 2012 adjusting and cleaning up the lines. Afterwards saved in .dxf and opened in Heidenhain placing the two different curves together (from bottom and lid) to run simultaneously in the CNC-lathe.

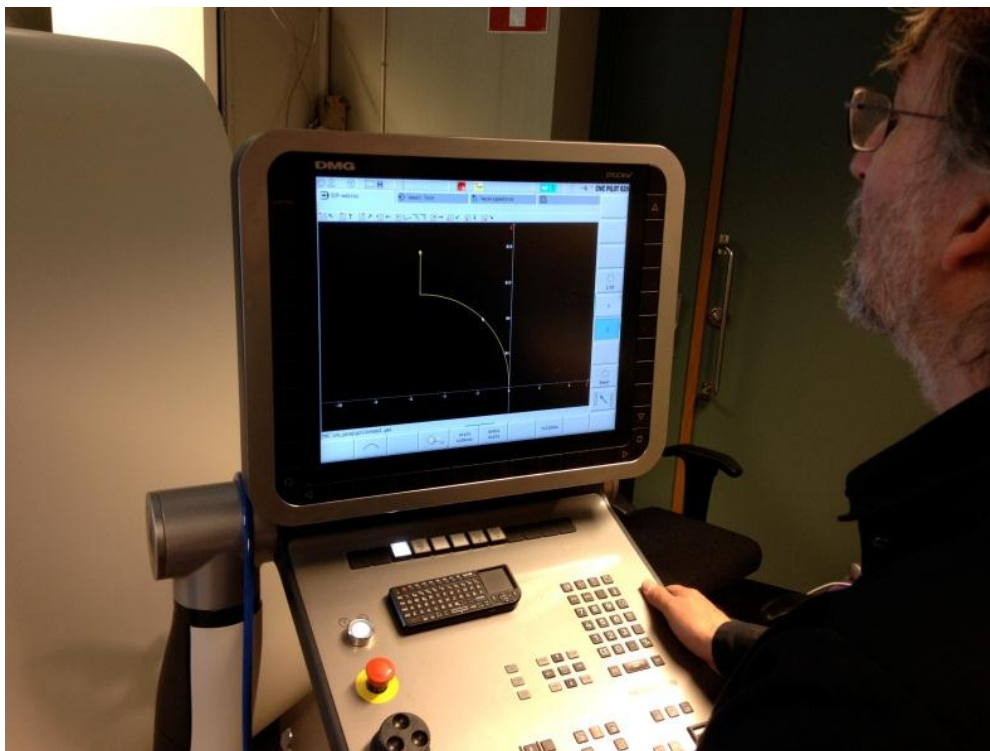

EXHIBIT 5-22 Picture of housing profile curve processed for the CNC-lathe.

5.4.6 CNC – logistic sequence

To be able to create the housing achieving a high end finish and saving time in the CNC-machines, a logistical sequence in which order the parts was going to be made was essential to make. Basically it was produced as follows:

1. Preparing parts to fit the lathe and mill - cutting the material in length, making a “heel” on backside to fit the machine chuck.
2. Bottom housing – CNC mill
 - a. Interior milling - removing the material, top of guide pins
 - b. Thread - inside
 - c. Guide pins – making the body, milling to the “heels”
 - d. “Heels” – making interior “heels”
 - e. Exterior rough milling - surface/”heel”/chamfer
 - f. Guide pins – making the snap-head
3. Top lid – CNC mill
 - a. Interior milling – removing material, rear side
 - b. Hole – rough middle hole
 - c. O-ring seat – outside
 - d. Thread – outside
4. Top lid – CNC lathe
 - a. Hole – finished middle hole in the lid incl. O-ring seating
 - b. Curvature – inside lid (dish)
5. Bottom housing + top lid – CNC lathe
 - a. Attach lid to bottom including O-ring
 - b. Curvature – outside housing/lid
6. Jig – CNC mill
 - a. Thread – outside
7. Bottom housing – CNC mill
 - a. Replace the top lid with jig, attached to chuck
 - b. Back – level out surface
 - c. Back – chamfer and hole
 - d. Exterior fine cut – press-fitting for cover ring
8. Cover ring – CNC mill
 - a. Inside – track
9. Cover ring – CNC lathe
 - a. Curvature - outside

5.4.7 β -prototype Design – Evaluation

The β -prototype that was produced using the CNC machines made the finish and precision with high quality. The product look and feel was significantly improved and all features from the α -prototype had got a satisfactory solution. The re designed outline made the product look more modern and there were two cover rings to choose from, one making it neater, one making it slicker. A meeting with IPsense was held and the prototype was now considered complete and ready to be tested to its specifications.

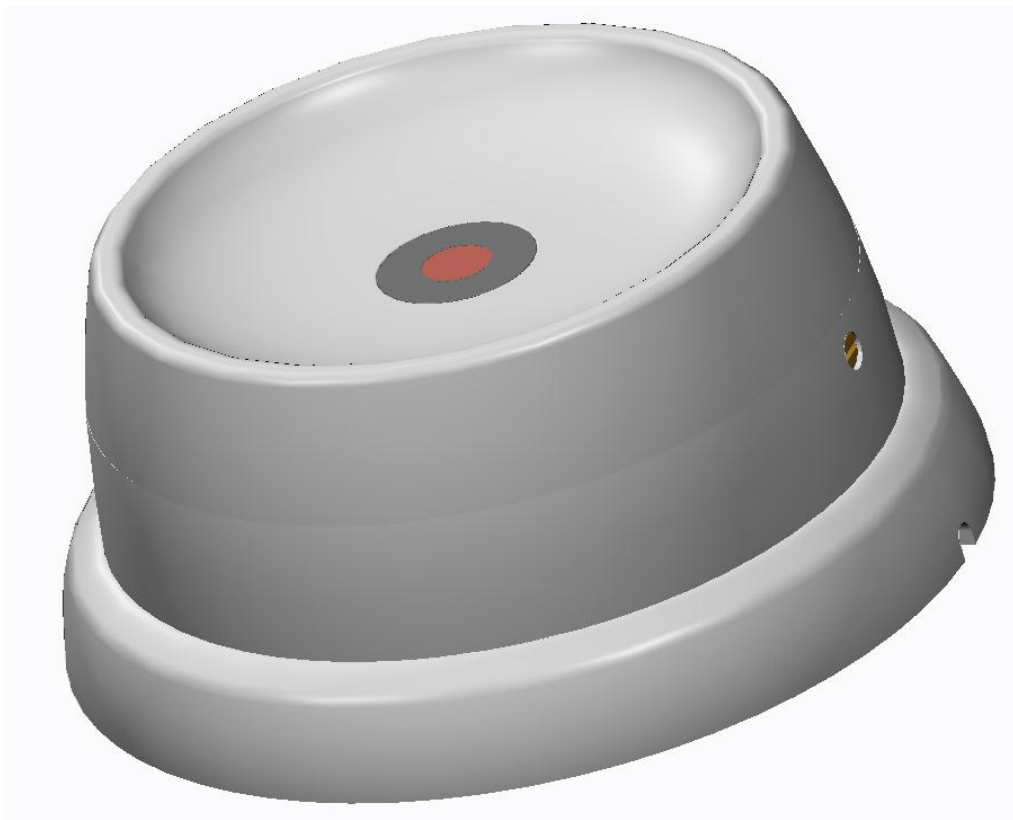

EXHIBIT 5-23 Picture of finished β -prototype housing.

5.5 Assembling β -prototype

The parts for the prototype were assembled as follows:

5.5.1 Housing

The bottom part of the housing was put together with following parts:

- 129.5 mm O-ring – attached on the top chamfer
- 4.1 mm O-ring – holes for locking screw
- M4 screw – locking screw
- Screw in vents, Gore® – attached from bottom side
- RUTASEAL® cable feed through – attached from bottom side
 - o Beagle board – attached to guiding pins inside



EXHIBIT 5-24 Picture of housing bottom side showing integrated sub-functions.

5.5.2 Microphone

The microphone circuit was designed and constructed by IPsense. This was placed inside the aluminum tube and glued in place using MMA epoxy and conductive silver-epoxy.

- 15.3 mm O-ring – placed on both side of aluminum tubing
- M16 x 1 nut – fastened from the bottom side of top lid
- Top-ring – fastened from the top side of lid
 - o Copper net – inserted in top-ring

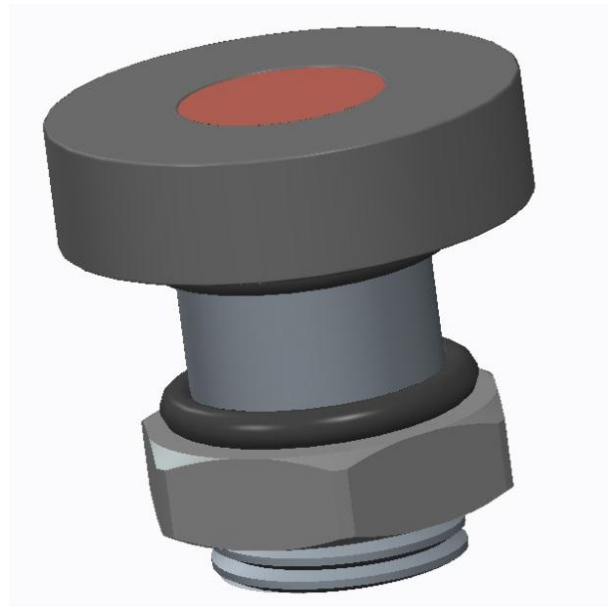

EXHIBIT 5-25 Picture, top-left embedment of microphone in silver epoxy, low-left tube orifice attached with Gore[®] membrane, right showing microphone assembled.

6 Product Testing

This chapter describes the purpose of the tests, how they were performed including an evaluation of the result. There are four different tests performed: sound, water resistance and heat.

6.1 Sound Test – Set up

The purpose with this test was to examine whether the top lid having a dish-design would have any effect in increasing the sound gain gradient (dB) compared to being mounted on a flat surface. The α -prototype was tested, made in cibitol. The design of the top-lid was 20-30 mm thick and around 130 mm in diameter. The rig would be exposed to different frequencies from a sound source that was moved around on different fixed locations parallel to the rig. Using a reference microphone placed on the test rig pole would render values to compare against throughout the test. The microphone would be able to receive sound from the sides as well as from the front and was mounted freely in the air, having no surface behind that would reflect the sound in any way.

The test was performed using a computerized data collection device set up outside an audio dead test room at V-section at LTH, Lund. The room had a square size and the test rig was positioned in the middle column (2/3) in the top row location (seen from above).

The test rig consisted of:

- Microphone – reference
- Sound source – active speaker
- Computer incl. data collection device
- Test product – α -prototype incl. microphone w. Gore-membrane



EXHIBIT 6-1 Picture of audio dead room, test device and computer program.

The tests were performed by mounting the α -prototype housing vertically on the top of a 2 m high metal pole. On top, next to the housing the reference microphone was attached. The sound source was placed on top of a 2 m high pole and was moved parallel to the test rig in five different fixed locations, testing the following frequencies: 200 Hz, 500 Hz, 1000 Hz and 2000 Hz. The result was noted on a piece of paper then transferred to Excel for analysis.



EXHIBIT 6-2 Picture of test rig on the pole having the sound source in front in different locations (not seen).

TEST RIG		POS 1
POS 2		POS 3
POS 4		POS 5

EXHIBIT 6-3 Picture is showing the different location of the sound source in relation to the test rig, which had same position during the test.

Three tests were performed on the α -prototype:

- Test 1: Microphone attached in top lid incl. bottom housing - complete
- Test 2: Microphone placed on “flat” surface - alone
- Test 3: Microphone Top lid only - partial



EXHIBIT 6-3 Picture is showing the different test rigs. From left: complete housing, middle: microphone only (apart from housing), right picture: top lid only including microphone. Reference microphone is seen in top left of pole.

6.1.1 Sound Test – Results

The test shows the following results:

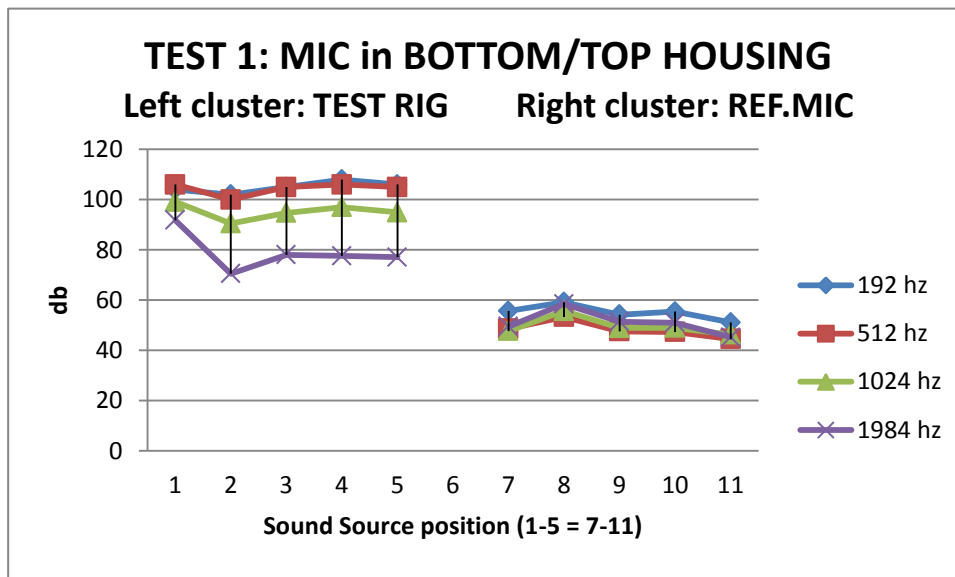

DIAGRAM 6-1 Test 1, Diagram displays testing of the complete housing. (See test rig on left side in diagram and reference microphone on the right side).

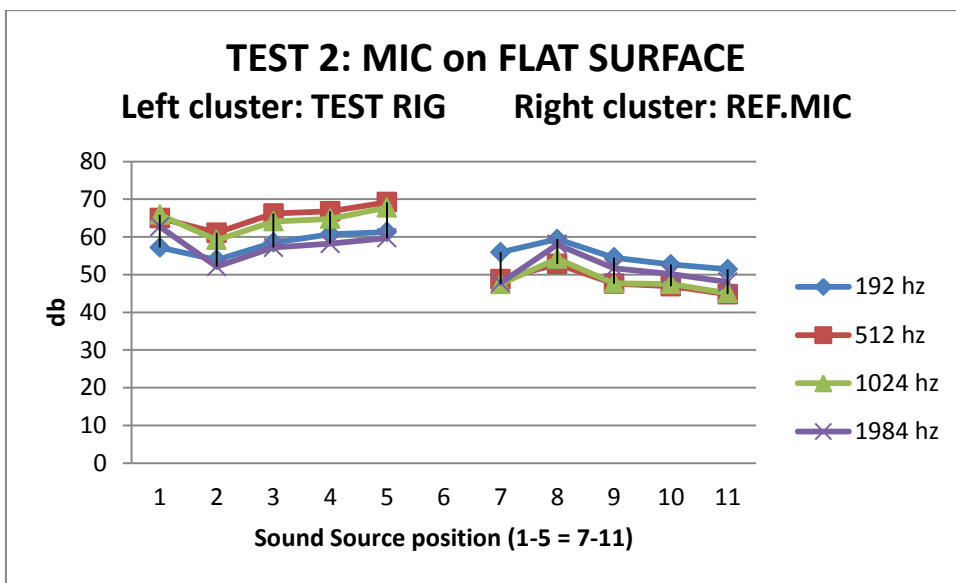

DIAGRAM 6-2 Test 2, Diagram displays testing of microphone on flat surface. (See test rig on left side in diagram and reference microphone on the right side).

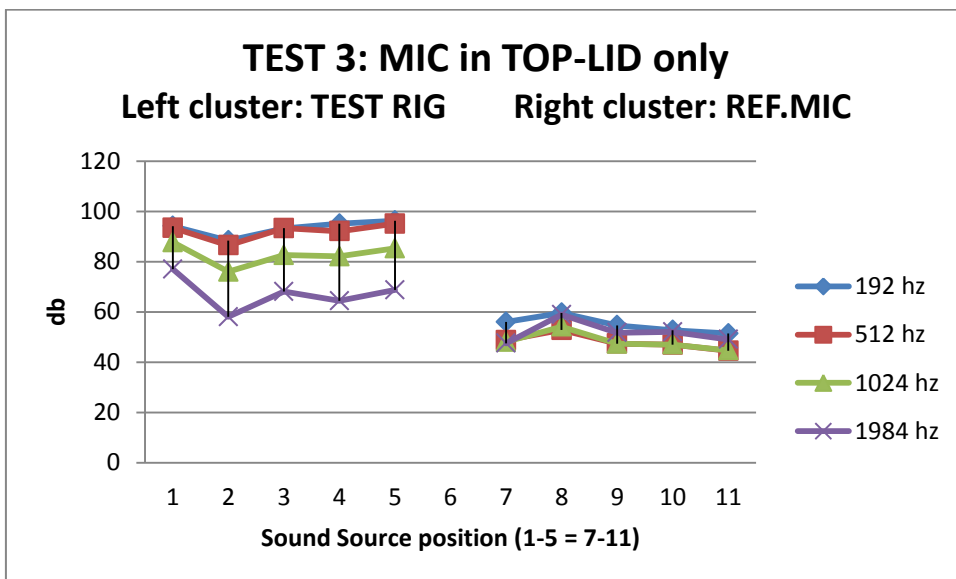

DIAGRAM 6-3 Test 3, Diagram displays testing of microphone in top-lid only. (See test rig on left side in diagram and reference microphone on the right side).

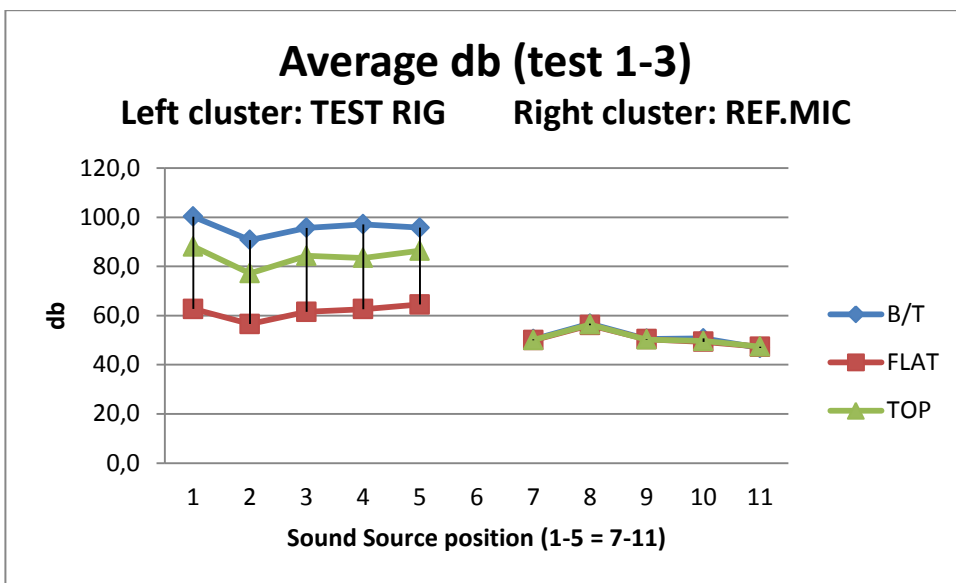

DIAGRAM 6-4 Diagram displays the average sum of the compiled data (db) from each position in each test, comparing the test rig against the reference microphone. (See test rig on left side in diagram and reference microphone on the right side. B/T = complete housing, FLAT = microphone on flat surface, TOP = top-lid only).

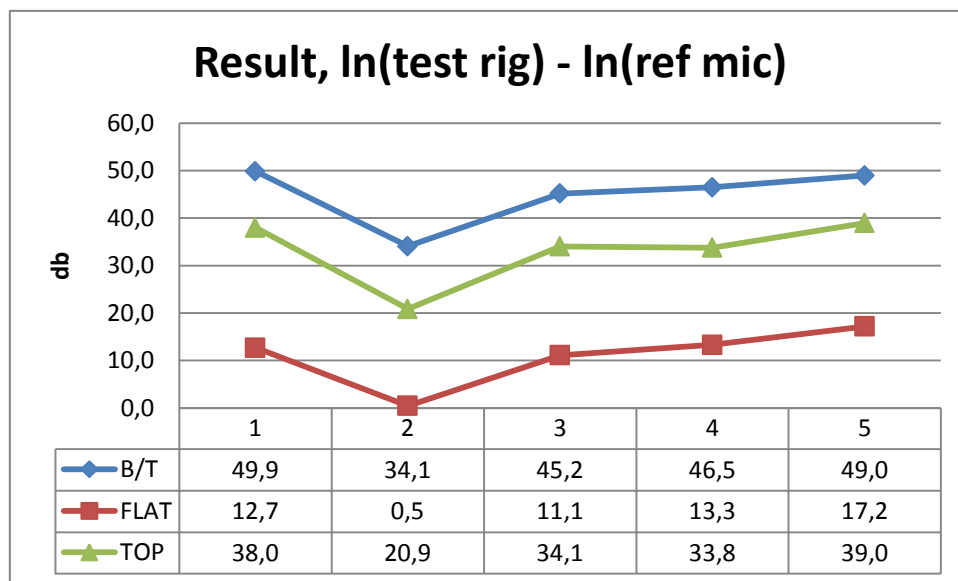

DIAGRAM 6-5 The diagram displays the difference in sound gain (dB) comparing test rig towards reference microphone. Since dB is logarithmic a division made by the two $\ln(\text{test rig} / \text{ref mic}) = \ln(\text{test rig}) - \ln(\text{ref mic})$ suggests that the result is $(\text{test rig}) - (\text{ref mic}) = \text{dB difference}$. B/T = complete housing, FLAT = microphone on flat surface, TOP = in top-lid only. To achieve a normalized result the “FLAT” test result needs to be subtracted from the results of “B/T” and “TOP”.

6.1.2 Sound Test – Evaluation

The results show that the sound pressure will increase using the background shape of a slightly concave surface.

Test 2 shows that when the test microphone is placed in front of a flat surface, using the plate on the test pole, the increase in sound pressure is about 10-15 dB compared to the reference microphone hanging by itself in the air. To normalize the result this difference needs to be subtracted from the results outcome of test B/T and TOP.

Looking in the “Result diagram” in position 1 it shows that the sound gain increases with approx. 5 dB compared to position 3-4. Compared to the ref. microphone this shows the opposite, which may seem logic since the sound source is located exactly to the right of the test rig. The angle of the sound was approx. 30° from the speaker cone, shot straight into the audio dead wall. Why the dB-gain still is increasing could be assumed to be about that any surface around the test microphone creates a self-resonance from behind, but this is still unclear.

Looking at the tests 1-3 in position 2 (sound source right in front) the test rig clearly shows a dip in the dB-gain compared to the reference microphone that shows a slight increase. This effect could appear because the microphone, on the test rig, doesn't pick up the sound frequencies directly from the sides as the reference microphone, because of its location in the aluminum tube. Or, it could be because the microphone hit the roof of its ability. Position 4, also in front but one step back shows no decrease in dB-gain, on the contrary an increase.

Test 1 showing, the test rig including complete housing, clearly indicates that the dish design increases dB-gain when the sound source is moved away from the test rig. Position 3 increases with 34,1 dB and position five, in the outer corner, showing 31,8 dB increase. This result is probably also an effect of the housing creating a self-resonance combined with the dish design. The average increase in relation to all five test points is 33,8 dB. (Compared to the test microphone hanging by itself = FLAT).

Test 2 was made for this reason, looking at the possibility of housing self-resonance being the only reason for the dB-gain to increase. In this test only the dish including microphone is tested. In fact it shows that the result based on the average dB-gain is 11,8 dB (44,9-33,1) less without the bottom housing but still shows an average increase of 33,1 dB. This indicates that the average housing dB produces a self-resonance a positive side effect.

TESTS	B/T	FLAT	TOP
1	49,9	12,7	38,0
2	34,1	0,5	20,9
3	45,2	11,1	34,1
4	46,5	13,3	33,8
5	49,0	17,2	39,0
AVERAGE	44,9	11,0	33,1

EXHIBIT 6-5 The compiled table showing average dB-gain from each test, frequency and position, 1-5.

6.2 Water resistance test – Set up

The purpose doing a water resistance test was to test the protection of the equipment inside the enclosure against harmful ingress of water, for IP66/65. This means using water jet beam sprayed on to the housing after it was fully assembled. (The beagle-board was not mounted inside). The test was carried out having the product attached to a pallet, then using a high pressure water device spraying from 2-3 m distance for 3-5 min.

The test rig consisted of:

- Pallet on wheels for product attachment
- Water jet source: Kärcher K 5.85 M Plus (140 bar, 490 l/min)
- Test product – β -prototype incl. microphone w. Gore[®]-membrane



EXHIBIT 6-4 Picture is showing water test rig sprayed with water jet.

6.2.1 IP 66/65 Coding

IP66: Powerful water jets should be used on the housing when testing. Water projected in powerful jets (12.5mm nozzle) against the enclosure from any direction shall have no harmful effects.

- a. Test duration: at least 3 minutes
- b. Water volume: 100 litres per minute
- c. Pressure: 100 kN/m² at distance of 3 m

IP65: Water projected by a waterjet nozzle (6.3mm) against enclosure from any direction shall have no harmful effects.

- d. Test duration: at least 3 min
- e. Water volume: 12.5 litres per minute at distance of 3 m

6.2.2 Water resistance – Results

After the product had been dismantled from the pallet it was dried up on the outside checked for cracks. No cracks or other separation in the material was showing. Afterwards the top-lid was removed, the inside floor showed pearl of water on it. Having examined all O-ring seats it wasn't clear which was poorly fitted, but it could have been the microphone seating. The Microphone itself showed no proof of leakage having a Gore® IP68 membrane mounted in the orifice of the tubing. The test results implicates that the housing doesn't approved for IP66/65, but the microphone does. (Since it leakage occurred inside the housing, the humidity test wasn't carried out).

6.3 Heat Test – Set up

The purpose with the heat test was to test the durability of the electronic circuit referred to as the beagle-board. Since it holds a micro-processor producing some heat the CPU was tested to run constantly at 100% of its capacity inside the housing that was closed.

The specification was set to cope a surrounding temperature of 50° not exceeding 85°-90° while running the CPU at 100%. (An oven was not used).

The test rig consisted of:

- Test product – α -prototype incl. microphone w. Gore®-membrane and beagle board inside powered with accumulator.
- Measure instrument – voltmeter incl. temperature probe



EXHIBIT 6-5 Picture is showing heat test set up including temperature.

6.3.1 Heat Test – Results

The test started at a room temperature of: 21,2°C. The final temperature stabilized at 39°C after 30 min. Final running time was 1 hour 10 min. Theoretically the analyze below shows that the beagle board would be able to run with CPU100% without if overheated.

Calculation:

- Final enthalpy change: $39 - 21,2 = \Delta t 17,8$
- Total temp: $50 + \Delta t 17,8 = 67,8^{\circ}\text{C}$
- Max temp $85 > 67,8 = \mathbf{17,2^{\circ}\text{C EXCEED}}$

6.4 EMC test

An EMC test aims to ensure that equipment items or systems will not interfere with or prevent each other's correct operation through spurious emission and absorption of EMI (electromagnetic interference). After discussions with IPsense the EMC test was cancelled due to the absence of test equipment. To be able to perform an EMC test requires further investigation concerning inside coatings²⁶ since some plastics are difficult to cover. According to G.W.P.A.G²⁷ POM is unsuitable to cover with metal coating. An alternative could be to insert a metal cover made in aluminum or copper.

²⁶ The metallization of plastic components by vacuum deposition (PVD) effectively screens noise-sensitive plastic components.

²⁷ <http://www.gwp-ag.com>

7 Reflections and discussion

This chapter contains conclusion and a discussion regarding the project in total.

At start the goal of the Master Thesis was to find the best mechanical housing solution to a sound analyzing product on behalf of IPsense, designed with an appropriate Industrial Design approach. This was because “the design should be tested and validated by manufacturing a prototype of the housing”. The prototype was made according to the optimal product design and development process, Ulrich & Eppinger, tight and structured method that leave nothing out. The prototype was conceived using state of the art CNC-technique (the machines were bought new only in autumn 2011 having not run many hours) including having made the drawing in the latest CAD program, CREO 1.0. The tests were made somewhat successful, at least said regarding the sound design which proved results that even the expert on structural mechanics couldn't explain. Increasing the sound pressure with almost 35dB with the design made for the housing! The goal must be considered to be achieved by far. Having this said, the product in this stage is still far from perfect.

To start off with, having set the boundaries for the project the design ideas started to flow quite well. But an obstacle at first was that the project was confidential and I was inexperienced on this market. It was decided on to use expert groups on internet researching the market. I'm used posing straight forward questions but I realized it wasn't possible, the risk was too big exposing the core idea to the groups. The experience done was to accomplish the goal anyway by trying to angle the questions differently. After some trial an error I started to get my answers from the groups, mainly through pools and comments that were made. Suddenly I was the “top influencer of the week” having got people hot on the idea of talking about the problems concerning supportive video surveillance related products. Despite that the project concept was confidential this must be seen as a very good result, now knowing the critical need and be able to validate the facts by IPsense.

The next step was to generate the design for the project which was done using the methods from Ulrich & Eppinger.

As a designer as well as an engineer I don't mind structure but in this project it is also about the Industrial Design package which needed to be combined somehow. The solution I saw was to use Ulrich & Eppinger regarding functionality in relation to the market need but the Industrial Design approach using Mood Board and market segmentation models acting to be an inspiration to the harsh design aspects. To be a designer as well as engineer, is a most individual experience, sometimes the design (surfaces, line-flow) is easier to sense sometimes the functionality is more obvious. Being too structured in the method will somehow make the design situation a bit too tense on the contrary to be too fuzzy about the functionality makes those thoughts snowed in. The bottom line is that you would actually gain on having each person with these characters involved in the product development process as expert help. There could have been more drawings made to analyze, more models built as well but this was not possible on the time given, I think that's why Ulrich & Eppinger states that a successful product is hard to accomplish in less than a year often it takes three to five years for the whole team. I now understand why and realize that the result from this process is exceptionally good but could be improved having had more time.

Making the prototypes was a good experience, at first by hand then with the CNC-machines. Having control in the manual process gave satisfaction always being able to see what's coming next if problems needed to be sorted. The CNC-process is more of a mystery because it can be done in different ways depending on how the drawing is processed from CAD. My supervisor advised me against using the CNC processing tools in CREO 1.0, creating the final CNC-files. This is apparently time consuming and may seem even more frustrating than to program the machines by you. In any case it's up to the CNC-operator if this is going to work, doing a complicated integrated design as this product has needs for a qualified operator and needs for someone to prep the files before him, after export from CREO 1.0. The process is quite complicated if the results shall be satisfying. However, the results from this process impressed the most, having the product made with such a high precision and quality finish was very satisfying at the least to say. Spot on.

Testing the product is a vital step that never could be given enough time. Analyzing my project plan afterwards makes it clear that this timeline could be longer in another project. I think this is what requires a lot of time making the project successful. The sound test was well prepared and even though the result was satisfying there could have been more tests made, using different microphones and other dish-designs.

Finally, the water resistance test showed leakage. The time to readjust the β -prototype finding out which O-rings seats needed to be corrected was not enough. This would need further investigations, making changes in CAD then post processed for the CNC guiding program. The process is another month to invest producing a new prototype. The results could be enough for IP64/63 coding as it seems or can be seen as a good sign that this area needs further examination.

8 Analysis and future improvements

This chapter consists of detailed analyses regarding design and production aspects and how these could be improved furthermore.

Detail analysis

1. **Thread** - An obstacle was to design the thread for the bottom in CAD using “helical sweep”, then do the same to the top-lid having them to fit. Not knowing how much space the O-ring would need to get the parts tight enough was a problem. There was also discussion with the CNC-operator if to make the thread in the lathe or in the mill. At first it seemed easier doing it in the lathe when the parts were put up there anyway, so special tools was ordered for this. A sales person from the company delivering tools attended to a meeting suggested them that there were tools for the mill also having it made there. It was then decided upon having making it in the mill due to better control.

Improvements: A thread analysis could be made using non finished parts to test for the optimum thread-feel. Before having decided on the method of making the thread a workshop meeting could be made, gathering all necessary information before having the decision made.

2. **CAD post processing** – Having made the .dxf files from CREO1.0 .prt via .drw caused a lot of extra labor having the file “cleaned” up in Autocad 2012 and saved once again before they could be open in the CNC guiding system (Heidenhain). The reason for this was that somehow there were double lines when opened in Autocad 2012. The files was made for doing the outline curvature in the CNC-lathe but was not satisfactory for the CNC-operator. When these “cleaned” up files was opened in the CNC guiding system they were not complete and bits and pieces of the line were missing. The process was time consuming causing some delay for the part to be made.

Improvements: Together with the supervisor it was found out that one may not use rotational symmetric parts without making an extrusion of the profile in a separate sketch. This part would then only have one line instead of two and didn't need to be "cleaned" up in Autocad 2012, it was only rotated and adjusted to the zero point (0,0,0).

3. **Dish design** – The design of the top-lid is made according to esthetical aspects and to improve sound sensitivity. The dish has a depth designed in regards to the sizing of the housing, if made too deep the microphone would not fit above the electrical circuit. Made too shallow the desired result may not be satisfactory.

Improvements: The outer rim of the dish could be tested with a chamfer made to improve sound pressure even more. Testing for different types of top-lid design is recommended to find out the golden section.

4. **Guiding pins** – The guiding pins for the beagle board is made with a snap-on head. The design was done requiring a special tool to mill the top part of the pins.

Improvements: To be able to snap-off the beagle-board a special tool could be made. The function also needs further refinements to work appropriately when having the unit served.

Results

Master Thesis

The thesis resulted in a tested β -prototype product developed through the product design and development process for the sound analyzing market. The housing combines an integrated construction and design for an intelligent electronic circuit, consisting of a microphone and the electronics. The housing was made according to the market needs and the technical specifications specified by IPsense. Then the most suitable design regarding the mechanical and industrial design solution for the purpose was selected. The prototypes was made throughout a controlled working process, at first handmade then CNC-machined via CAD. The design of the housing possibly housed some new findings regarding sound mechanics operating on a plain structure of a dish-surface regardless of the focus point.

The design for the top-lid and housing will result in a design patent applied for by IPsense.

Project follow up

The Gant scheme shows the following according to the project time distribution:

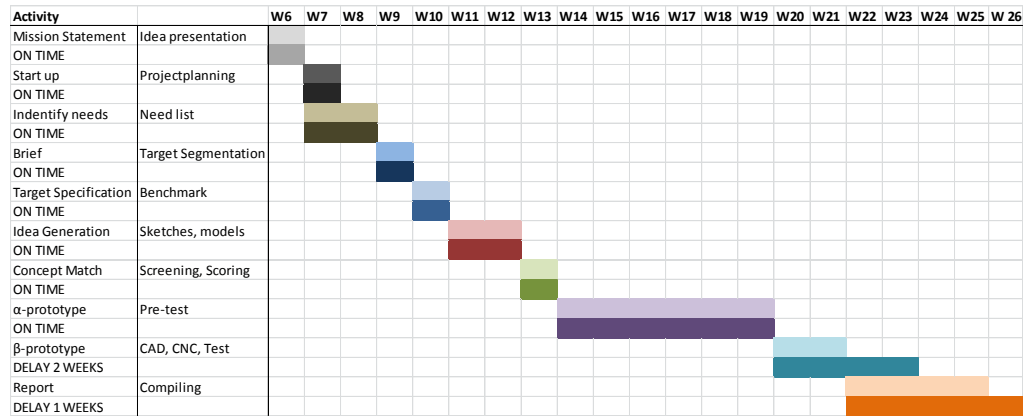

The project was well performed throughout the weeks used resulting in a one week of delay comparing to the origin planning. Two weeks of delay is related to CNC process because of the post processing of files. The total delay was shortened by 1 week during report compiling. Comparing to the Master Thesis total length of 20 weeks no delay has been made, the project stops at 20 weeks in total.

Resource distribution

The master Thesis was performed by the author by 100 % alone. The resource used at the IKDC school facility was the CNC-milling machinery including CNC-operator who was involved in producing the β -prototype during w. 20-w. 24.

Experience learned from the project

An experience that was made was that 20 weeks is a short period of time when it comes to generate a new product, especially by you alone. In regards to the generation of multiple pre-models, being able to optimize further by testing more solutions to the dish-design, the following could be done. Combine the Master Thesis concerning product development processes with students from other programs needed for the development process. In this case the thesis could have been made in collaboration with an Industrial Design student.

Concerning CNC-processing it was clear that this process was going take quite a lot of time occupying the CNC-operator in the post processing process of data files. This could be considered in other project when it comes to the planning of resources being allocated for a project and how to solve this issue.

Reference list

Chapter 1

<http://www.idg.se/2.1085/1.440701/fra-ar-ett-storre-hot-an-tillgang>

http://www.riksdagen.se/sv/Dokument/Lagar/Forslag/Motioner/Videokameraovervakning-i-taxi_GO02Ju803/?text=true

Sommerville, Software Engineering 8, page 108

Chapter 2

Brainstorming: Osborn, A.F. (1963) *Applied imagination: Principles and procedures of creative problem solving* (Third Revised Edition). New York, NY: Charles Scribner's Sons

Productivity Loss in Brainstorming Groups: Toward the Solution of a Riddle. *Journal of Personality and Social Psychology*: 497–509. 1987

Chapter 3

Product Design and development by Karl T. Ulrich and Steven D. Eppinger, chapter 1, page 2-9, Fourth Edition, McGraw-Hill Education 2008

Chapter 4

Product Design and development by Karl T. Ulrich and Steven D. Eppinger, chapter 4-7, Fourth Edition, McGraw-Hill Education 2008

<http://sv.wikipedia.org/wiki/Moodboard>

Nigel Cross, Engineering Design Methods, Jon Wiley & Sons Ltd, 2000

Design Brief: http://www.kth.se/polopoly_fs/1.220889!/Menu/general/column-content/attachment/Hur%20man%20skriver%20en%20designbrief.pdf

Modular Design: Baldwin, C.Y., Clark, K.B., "The Option Value of Modularity in Design" Harvard Business School, 2002

Leaf: Haupt, Arthur Wing, Plant morphology. Publisher: McGraw-Hill 1953, <http://www.archive.org/details/plantmorphology00haupt>

Ear: NeurOreille and authors (2010). "Journey into the world of hearing" <http://www.cochlea.org/en/spe>

Louroe: <http://www.louroe.com/products.php?id=7>

Reference list

Satellite dish: <http://peterkristiansson.se/parabol.html>

Chapter 5

Product Design and development by Karl T. Ulrich and Steven D. Eppinger, chapter 9, Fourth Edition, McGraw-Hill Education 2008

Rapid prototyping: Create It Real. "3D Printer Technology - Animation of layering (CreateItReal.com)"

Resin casting: Harper, Charles A. (2003). In *Plastics Materials and Processes: A Concise Encyclopedia*. Wiley-Interscience . pp. 80–82 <http://www.trekprops.de/wip-odn-scanner-part-2>

CNC: Pease, William (1952) *Scientific American* (3): pp. 101–115, <http://blog.modernmechanix.com/an-automatic-machine-tool>

The Pyramid material: <http://www.npgroup.se/valj-ratt-material/materialpyramid/>

Olefin fibers: Hegde, Dahiya, Kamath, Raghavendra R., Atul, M. G.; Haoming Rong & Monika Kannadaguli (April, 2004), *Olefin Fiber*, <http://web.utk.edu/~mse/pages/Textiles/Olefin%20fibers.htm>, retrieved 2007-06-20

Prototyping: <http://www.qimtek.se/category/prototypillverkning-99.html>

http://www.pcmag.com/encyclopedia_term/0,1233,t=prototyping&i=49886,00.asp

Faraday cage: J. D. Krauss, *Electromagnetics*, 4Ed, McGraw-Hill, 1992

Rutaseal: http://www.rutab.se/egna_produkter/rutaseal_rutaseal_light_1

Gore: http://www.gore.com/en_xx/products/venting/index.html

Telephone interview regarding material: Anders Jonsson, Nordic plastic Group

Chapter 6

Product Design and development by Karl T. Ulrich and Steven D. Eppinger, chapter 8, Fourth Edition, McGraw-Hill Education 2008

IP code: <http://www.ce-mag.com/archive/06/ARG/bisenius.htm>

EMC: http://en.wikipedia.org/wiki/Electromagnetic_compatibility

<http://www.gwp-ag.com/en/services/series-production/surface-treatments/emc-coating/index.htm>

Contacts

RUTAB, Christian Svensson, Sales +46 (0)380-55 50 50

W.L. Gore, Madeleine Stark, Industrial Prod. div, +46 (0)31-706 78 51

Malmö Maskin, Markus, sales +46 (0)40-220 200

Nordic Plastic Group, Anders Jonsson, sales +46 (0)40 671 51 65

