

Management of hydrogen sulfide in anaerobic digestion of enzyme pretreated marine macro-algae



LUND
UNIVERSITY

Salar Haghighatafshar

Water and Environmental Engineering
Department of Chemical Engineering
Master Thesis 2012

Management of hydrogen sulfide in anaerobic digestion of enzyme pretreated marine macro-algae

by

Salar Haghghatafshar

Master's thesis number: 2012-09

Water and Environmental Engineering
Department of Chemical Engineering
Lund University

June 2012

Supervisor: **Research assistant Åsa Davidsson**

Co-supervisor: **Hamse Kjerstadius**

Examiner: **Professor Jes la Cour Jansen**

Picture on front page: Collection of algae on Skåre harbour – Trelleborg, Skåne/Sweden

Postal address

P.O. Box 124
SE-221 00 Lund, Sweden

Web address

www.vateknik.lth.se

Visiting address

Getingevägen 60

Telephone

+46 46-222 82 85
+46 46-222 00 00

Telefax

+46 46-222 45 26

Acknowledgements

In an experimental study, as heavy and intense as this thesis work has been, not one person but a group of people are certainly engaged who without their cooperation and contributions achievement of reliable results and conclusions would be unreachable. Therefore, I would like to thank *Svetlana Öfverström* and *Hamse Kjerstadius* for helping in different steps of the study from onsite collection of algae to the pretreatment and digestion processes. Similarly, I would like to recognize the contribution of VA SYD for provision of the pilot-scale reactors and the workshop as well as their crew who openly helped us when needed.

I would like to appreciate *Ellinor Tjernström* and *Annika Hansson*, from municipality of Trelleborg/Sweden, who took their time in the freezing weather of January and showed me the most potential locations where considerable amounts of algae could be found. Special thanks to *Ellinor* for identifying different species of algae included in this study.

Thanks to all the Water and Environmental Engineering group at Chemical Engineering Department who provided a friendly and intimate environment which indeed is always necessary for accomplishment of a research study. Special gratitude of mine is expressed to *Gertrud Persson* who taught me how to follow and perform laboratory practices and procedures. Once more, I would like to thank *Gertrud* for the continuous analysis of over 150 VFA samples since the beginning of the experiment in spite of all the difficulties she faced.

I would also like to express my gratefulness to my supervisor *Åsa Davidsson* as well as my examiner *Jes la Cour Jansen* who amenably provided answers to my questions. Thanks for financing the study and allowing me to do all the needed analyses with all the needed material.

At the end, I like to thank my beloved parents back home for all their supports as well as my lovely spouse, *Mana*, who not only tolerated her loneliness during all those long hours of my absence, but also helped me in any way she could.

Summary

Accumulation of large masses of algae on the beaches may happen seasonally as a result of green tides phenomenon. Long term resident of algal piles on the beaches would seriously cause inconveniences regarding recreational aspects of coastlines as well as negative environmental impacts. Occurrences of various insects in the piled masses and domination of anaerobic conditions leading to emissions of unpleasant smell (including hydrogen sulfide's smell) are the most straight forward results of the phenomenon. Anaerobic digestion of algae can be a beneficial process which not only is capable of solving the pollution problem mentioned above, but also has a potential to produce amounts of energy as biogas.

On the way towards anaerobic digestion of algae, in a continuous implementation, crucial problems have to be faced and handled. Availability of algae year-round, collection, preparation, and finally its efficient digestion have significant challenges. In this study, it was tried to suggest an applicable method for pretreatment in addition to coping with hydrogen sulfide generation and its impact on digestion processes at thermophilic (55°C) and mesophilic (35°C) temperatures.

Enzymatic pretreatment of algae – by means of cellulose degrading enzyme – was evaluated through lab-scale and pilot-scale experiments. The degradation efficiency of the enzyme depended on the initial physical quality of the algae. The fresh algae collected in February 2012 was found to be resistant against enzymatic attacks, whereas already degraded algae, collected in April 2012, was further degraded by the enzyme resulting an efficiency of 40% regarding the solids content.

Lab-scale batch anaerobic digestion experiments showed comparatively low methane potential for the pretreated algae at both mesophilic and thermophilic temperatures. However, the raw algae (cut into small pieces) were found to be hardly hydrolysable. The methane potential of raw algae in thermophilic and mesophilic digestion was about 17 NmL/gVS and – 36 NmL/gVS (negative value) respectively. Presence of inhibitory agent(s) was obvious at both temperatures.

Very fast growth of sulfate-reducing bacteria was noticed in the continuous digestion, so that in less than 20 days, hydrogen sulfide concentrations over 10000 ppm were observed in both meso- and thermophilic reactors. Inhibition of methanogenesis in the thermophilic reactor occurred at unionized dissolved sulfide concentration of about 22 mg/L (10000 ppm in the biogas) while it was mainly non-SRB acetogens that were inhibited in the mesophilic reactor at unionized sulfide concentrations as high as 50 mg/L (17000 ppm in the biogas). This shows that thermophilic digestion is more prone to be inhibited at high sulfide concentrations regarding methanogenesis.

Micro-aeration was found to be more efficient in the thermophilic reactor while its effect on the mesophilic process was negligible. Addition of iron (III) chloride substantially decreased the sulfide level in the headspace of the reactors but the amount of sulfide reduction in the biogas (in the gas collector) was relatively lower. This could be accounted for different

reaction rates of sulfidogenesis and sulfide oxidation. In this case high amounts of sulfide are generated and consequently transported into the gas collector while the overpressure in the headspace of the reactors does not allow backflow of hydrogen sulfide to the reactor for further oxidation, meanwhile major portion of the sulfide in the reactor can be oxidized.

Table of abbreviations

A-MPB	Acetotrophic methane producing bacteria
A-SRB	Acetotrophic sulfate-reducing bacteria
BGP	Biogas Plant
COD	Chemical Oxygen Demand
CSTR	Continuously-stirred tank reactor
FPU	Filter paper unit
H-MPB	Hydrogenotrophic methane producing bacteria
H-SRB	Hydrogenotrophic sulfate-reducing bacteria
LCFA	Long-chain fatty acids
MPB	Methane-producing bacteria (methanogens)
SRB	Sulfate-reducing bacteria
SRT	Solids retention time
TS	Total solids
UASB	Up-flow anaerobic sludge blanket
VFA	Volatile fatty acids
VS	Volatile solids
WWTP	Wastewater Treatment Plant

Table of Contents

1. Background	1
1.1. Aim.....	3
2. Literature study	5
2.1. Origin of hydrogen sulfide	5
2.2. Competition over hydrolytic bacteria.....	7
2.3. Competition over intermediates	7
2.4. Competition over mutual substrates	7
2.4.1. Hydrogenotrophic methanogens versus SRB	7
2.4.2. Acetotrophic methanogens versus SRB	7
2.5. Sulfide toxicity (inhibitory behavior).....	9
2.6. Reduction of hydrogen sulfide via external agents	12
2.6.1. Precipitation	12
2.6.2. Sulfide oxidation	12
2.7. Sulfide dissociation	13
3. Methodology	15
3.1. Material and method.....	15
3.1.1. Reactors.....	15
3.1.2. Analyses and measurements.....	15
3.1.3. Inoculation.....	16
3.1.4. Substrate	16
3.2. Pretreatment	17
3.2.1. Cutting algae	17
3.2.2. Enzymatic pretreatment.....	18
3.3. Micro-aeration method.....	20
4. Results and discussions	23
4.1. Enzymatic pretreatment of algae (lab-scale).....	23
4.2. Enzymatic pretreatment of algae (pilot-scale).....	26
4.3. Continuous digestion of pretreated algae	28
4.3.1. Initiation of inhibition (day 1 to 25).....	29
4.3.2. Sulfide treatment, a micro-aeration study (day 26 to 52).....	35
4.3.3. Short term trials for sulfide reduction	36
5. Conclusions	39
6. Future studies	41
7. References	43

1. Background

Recent elevated demand for renewable energy as a substitute for fossil fuels has conducted attentions towards anaerobic digestion so that over 750 anaerobic digestion plants were installed between 1982 and 2002 all over the world (Kassam *et al.*, 2003). However, obstacles such as hydrogen sulfide, high carbon dioxide content, presence of water vapor, slow hydrolysis rates under anaerobic conditions, and high sensitivity of anaerobic bacteria to changes in wastewater composition; restrict the full industrial application of biogas (Noyola *et al.*, 2006; Leitao *et al.*, 2006). Different treatment processes needed for the produced biogas based on its application is shown in Table 1-1.

Table 1-1. Treatment processes of biogas for different applications (Noyola *et al.*, 2006) – adopted with permission.

Application	Removal of H ₂ O	Removal of CO ₂	Removal of H ₂ S
Electricity generation (turbine or engine)	P-C	N-P-C	P-C
Heating	P	N	N-P-C
Co-generation	P-C	N-P-C	P-C
Vehicle fuel	C	C	C
Introduction to a natural gas grid	C	C	C

N: No treatment; P: partial removal; C: complete removal

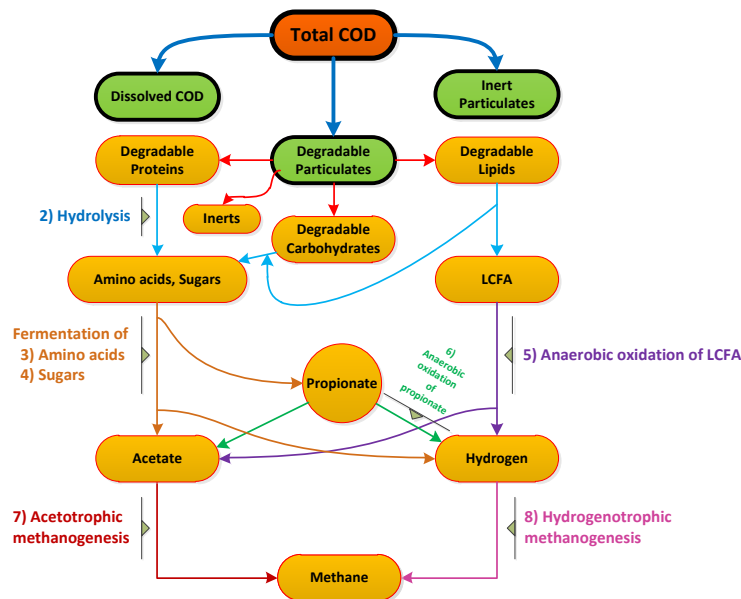

Figure 1-1. Total COD Flow and conversion processes in anaerobic digestion based on Gujer and Zehnder (1983) - reproduced with permission from IWA publishing.

Different groups of microorganisms grow under anaerobic conditions. Amino acids fermentators, sugar fermentators, long-chain fatty acids (LCFA) oxidizers, propionate oxidizers, acetotrophic methanogens (A-MPB), and hydrogenotrophic methanogens (H-MPB) play the required roles in methane production according to the conversion model suggested by Gujer and Zehnder (1983) - Figure 1-1. However, intermediate products (i.e.

acetate, propionate, and hydrogen) are commonly used by methanogens and sulfate-reducing bacteria when sulfur/sulfate is present in the substrate. Consumption of hydrogen, acetate and propionate leads to undesired decrease in methane whereas toxic hydrogen sulfide is produced.

Hydrogen sulfide production in the biogas from sulfur (sulfate)-rich wastewaters (substrates) may cause serious problems in application of biogas. Hydrogen sulfide, besides its unpleasant smell and corrosive nature which reduces the lifespan of pipework and other different installations in biogas industry, is also highly toxic to living beings. Among those living beings, microorganisms that produce methane through anaerobic digestion are more vulnerable since they are openly exposed to sulfide concentrations. Thus, high concentrations of hydrogen sulfide may harm the digestion process prior to any other living organisms. So it is crucial to look for applicable methods and techniques in order to solve the hydrogen sulfide issue to be able to introduce new substrates into anaerobic digestion.

Accumulation of large piles of seaweed on beaches (Figure 1-2) may cause unpleasant odor (Charlier *et al.*, 2007) due to predomination of anaerobic conditions hence formation of gaseous sulfur-containing compounds such as hydrogen sulfide. The problem with accumulation of algae is not only restricted to bad odor but also some health problems may be caused by such emissions due to continuous inhalation of sulfide (Peu *et al.*, 2011). In order to meet the problem authorities collect the piled up seaweed on the beaches and store it temporarily during spring and summer and later on in autumn and winter release them back into the sea. Algae, however, can be used as fertilizer via spread on agricultural lands but its salinity, sometimes high cadmium (Cd) content and high amount of trapped sand limit such an application. Algae are introduced as toxic wastes in Sweden because of their sometimes high Cd content (Nkemka and Murto, 2010).



Figure 1-2. Piled seaweed on the Baltic coast, southern Sweden (Skåre).

Additionally, the conflict that unwanted algae during summer time cannot be used on agricultural fields (due to existence of crops) increases the long-term storage costs (Peu *et al.*, 2011). As an alternative, different species of marine macro-algae has been studied as a potential source of energy during recent years. Anaerobic digestion of macro-algae is experimented in various ways with respect to digestion techniques and/or algal species.

Different species of brown, blue, green, and red algae are studied for methane production. As it is repeatedly reported, methane yield from anaerobic digestion of different species of macro-algae barely exceeds $0.3 \text{ m}^3 \text{ kg}^{-1} \text{ VS}_{\text{fed}}$ (Yuan *et al.*, 2011; Chynoweth and Srivastava, 1980; Ghosh *et al.*, 1981; Toriano *et al.*, 1976; Hanssen *et al.*, 1987; Habig *et al.*, 1984; Hanisak, 1981; Rigoni-Stern *et al.*, 1990; Hansson, 1981), thereby alternative methods are suggested. For example in specific case of *Ulva sp.* pressing the seaweed and digestion of the extracted juice (Briand and Morand, 1997; Morand *et al.*, 2006), digestion of ground dried algae (Briand and Morand, 1997; Bruhn *et al.*, 2011), and co-digestion of algae with other substrates such as livestock manure (Briand and Morand, 1997) are suggested. Nkemka and Murto (2010) used a two-stage process by which produced leachate from algae (first stage) was then digested in a UASB reactor (second stage). Furthermore, enzymatic pretreatment of macro-algae for anaerobic digestion seems to be an undiscovered area which is investigated to some extent in this study.

Deposits of sand present in the fed algae may affect the hydraulic retention time (HRT) in continuously-stirred tank reactors (CSTR) in case the substrate has high trapped sand content (Briand and Morand, 1997; Morand and Briand, 1999). Marine algae are usually associated with high concentrations of sulfate which during anaerobic digestion yields high concentrations of hydrogen sulfide (Amanieu *et al.*, 1975; Viaroli *et al.*, 1995 and 1996; Castel *et al.*, 1996; Cecchi *et al.*, 1996; Briand and Morand, 1997; Zamalloa *et al.*, 2012; Nedergaard *et al.*, 2002). This is specifically important in digestion systems with suspended cultures such as CSTR which are more susceptible to sulfide toxicity in comparison with attached biomass reactors like UASB (Omil *et al.*, 1995). However, regarding utilization of produced biogas it is recommended to be treated before combustion if hydrogen sulfide concentration is above 250 ppm (Gayh *et al.*, 2010). Considering obstacles stated above and low density of algae (causing severe problems in feeding the CSTR) and high refractory content (Briand and Morand, 1997), macro-algae are classified as difficult substrates for anaerobic digestion via continuously-stirred tank reactors (CSTR).

1.1. Aim

In this study, technical feasibility of digestion of marine macro-algae through continuous anaerobic digestion was looked into. Different problems from collection and preparation of algae to the digestion process and produced biogas - both in quantity and quality - were taken into consideration. Additionally, evaluation of the problems caused by hydrogen sulfide was considered as a major aim in this study.

Since sulfide production is a biological process done by sulfate-reducing bacteria (SRB) which consume mutual substrates with methane-producing bacteria (MPB); changing

process parameters such as solids retention time (SRT), temperature, pH, organic loading rate (OLR) for driving the competition towards the interest of methane producing bacteria (MPB), seemed to be extraordinarily interesting. However due to practical difficulties and limited available time, precipitation of sulfide via addition of external agents such as iron chloride and oxygen (micro-aeration) were tested.

2. Literature study

2.1. Origin of hydrogen sulfide

Depending on the composition of the substrate, different groups of microorganism are potentially capable of multiplication. One of the major anaerobic species is sulfate-reducing bacteria (SRB) which grow in presence of sulfate, sulfite, or thiosulfate:

Trophic reactions:

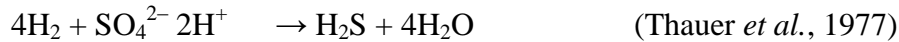
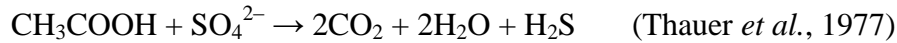

Dissimilatory reactions:



Sulfate reducing bacteria (SRB) are reportedly capable of utilizing not only methanogenic substrates such as hydrogen, acetate, formate, pyruvate, and methanol (Bock *et al.*, 1994) but also propionate, succinate, fumarate, butyrate, higher and branched fatty acids, malate, lactate, ethanol and higher alcohols, and aromatic compounds (Colleran *et al.*, 1995). Different reactions conducted by SRB, methane producing bacteria (MPB), and syntrophic bacteria are shown in Table 2-1. Sulfide, as a product of SRB activity in digestion of sulfate-rich substrates is distributed among different forms as S^{2-} , HS^- , and dissolved H_2S as follows:

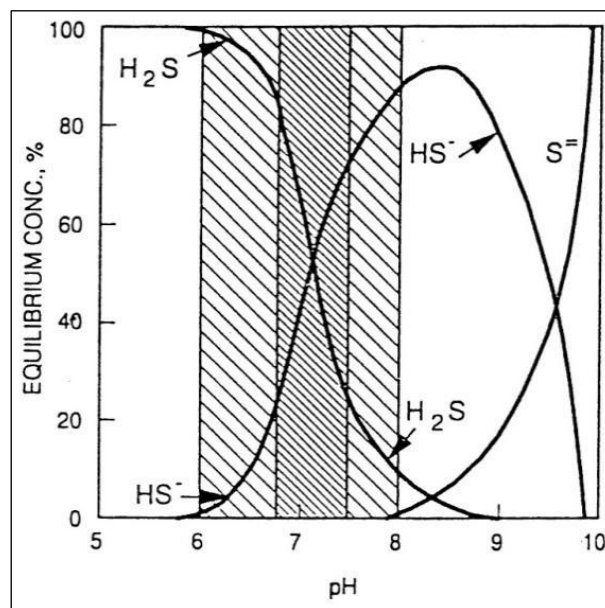
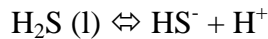

Figure 2-1. Distribution of different sulfide forms based on pH (Lens *et al.*, 1998) – used with permission.

Consequently, the concentration of sulfide's different forms is significantly controlled by the pH of the solution (Figure 2-1). As it can be seen, in neutral pH only first dissociation of hydrogen sulfide - $pK_a = 6.9$ at 30°C – (Lide, 1993) is of importance while di-anion sulfide emerges at pH above 8. Also the ratio between dissolved H_2S and gas phase follows Henry's law assuming static conditions in the reactor which is discussed in section 3.2.

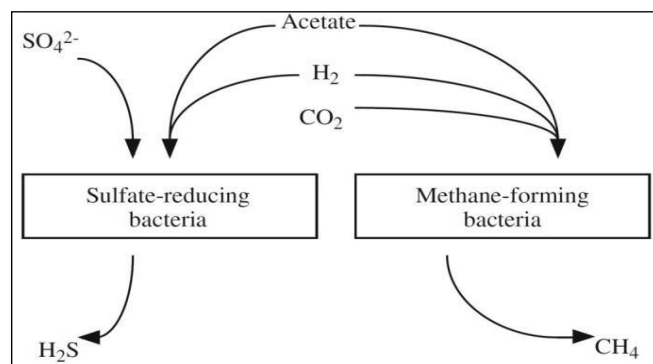

Figure 2-2. Common use of hydrogen and acetate by sulfate reducing bacteria and methanogens (Gerardi, 2003) – used with permission.

Considering the stoichiometry suggested by Thauer *et al.* (1977), SRB compete with both acetogenic and methanogenic bacteria over the available substrate. Many studies have concluded that SRB are able to stimulate propionate degradation (McCartney and Oleszkiewicz, 1991; Parkin *et al.*, 1990; Qatibi *et al.*, 1990; Harada *et al.*, 1994; Colleran *et al.*, 1995); whereas addition of propionate enhances sulfate reduction as well (Ueki *et al.*, 1988, 1992). Also it is well described that sulfate reducing bacteria (SRB) and methane producing bacteria (MPB) compete over the same substrate, i.e. molecular hydrogen and acetate, for survival (Figure 2-2).

Table 2-1. Bio-chemical reactions for sulfate-reducing, acetogenic, and methanogenic reactions (Lens *et al.*, 1998) – reproduced with permission.

Reactants	Products	ΔG° (Kj/mol)
<i>Sulfate-reducing reactions</i>		
$4\text{H}_2 + \text{SO}_4^{2-} + \text{H}^+$	$\rightarrow \text{HS}^- + 4\text{H}_2\text{O}$	-38.1
Acetate + SO_4^{2-}	$\rightarrow \text{HS}^- + 2\text{HCO}_3^-$	-47.6
Propionate + $\frac{3}{4}\text{SO}_4^{2-}$	$\rightarrow \frac{3}{4} \text{HS}^- + \text{Acetate}^- + \text{HCO}_3^- + \frac{1}{4}\text{H}^+$	-37.7
Propionate + $\frac{7}{4}\text{SO}_4^{2-} + \frac{1}{4}\text{H}_2\text{O}$	$\rightarrow \frac{7}{4} \text{HS}^- + 3\text{HCO}_3^- + \frac{1}{2}\text{H}^+ + \frac{1}{4}\text{OH}^-$	NR
Butyrate + $\frac{1}{2}\text{SO}_4^{2-}$	$\rightarrow \frac{1}{2} \text{HS}^- + 2 \text{Acetate}^- + \frac{1}{2}\text{H}^+$	-27.8
Butyrate + $\frac{5}{2}\text{SO}_4^{2-} + \frac{1}{4}\text{H}_2\text{O}$	$\rightarrow \frac{5}{2} \text{HS}^- + 4\text{HCO}_3^- + \frac{3}{4} \text{H}^+ + \frac{1}{4}\text{OH}^-$	NR
<i>Acetogenic reactions</i>		
Propionate + $3\text{H}_2\text{O}$	$\rightarrow \text{Acetate}^- + \text{HCO}_3^- + \text{H}^+ + 3\text{H}_2$	+76.1
Butyrate + $2\text{H}_2\text{O}$	$\rightarrow 2 \text{Acetate}^- + \text{H}^+ + 2\text{H}_2$	+48.3
<i>Methanogenic reactions</i>		
$4\text{H}_2 + \text{HCO}_3^- + \text{H}^+$	$\rightarrow \text{CH}_4 + 3\text{H}_2\text{O}$	-33.9
Acetate + H_2O	$\rightarrow \text{CH}_4 + \text{HCO}_3^-$	-31.0

Note: NR, Not reported

2.2. Competition over hydrolytic bacteria

Reportedly, SRB are not capable of degrading biopolymers such as starch, lipids, and protein. Consequently no competition is likely to occur in the hydrolysis step in anaerobic digestion (Hansen, 1993). The effect of sulfide toxicity on hydrolytic bacteria is not widely included in the literature.

2.3. Competition over intermediates

All types of SRB are able to utilize propionate which is found to be a key intermediate in anaerobic digestion (Chen *et al.*, 2008). Degradation of propionate by SRB leads to production of acetate, sulfide and carbon dioxide which is considered as an incomplete conversion to acetate (O'Flaherty *et al.*, 1998a; Thauer *et al.*, 1977). High affinity of SRB to propionate and their faster growth rate is demonstrated in different studies (Parkin *et al.*, 1990; Uberoi and Bhattacharya, 1995; Omil *et al.*, 1996a). This privilege can be supported by relatively higher maximum growth rate (μ_{\max}) and lower half saturation constant (K_s) of SRB than those of syntrophic bacteria i.e. 0.15d^{-1} and 23 mg/L for SRB and 0.05d^{-1} and 34 mg/L for syntrophic bacteria, respectively (O'Flaherty *et al.*, 1997, 1998b). Such a kinetic superiority makes sulfidogenic oxidation to be the main degradation pathway of propionate (Mulder, 1984; Ukei *et al.*, 1988; Qatibi *et al.*, 1990; Hepner *et al.*, 1992; Colleran *et al.*, 1994, 1998; O'Flaherty *et al.*, 1997, 1998a).

2.4. Competition over mutual substrates

2.4.1. Hydrogenotrophic methanogens versus SRB

The studies concerning the competition of SRB and MPB over hydrogen are quite consistent. It is shown that H-SRB (hydrogen utilizing sulfate-reducing bacteria) outcompete H-MPB (hydrogenotrophic methane producing bacteria) in presence of sufficient concentrations of sulfate (Mulder, 1984; Rinzema *et al.*, 1986; Rinzema and Lettinga, 1988a; Visser *et al.*, 1993c; Harada *et al.*, 1994; Uberoi and Bhattacharya, 1995; Omil *et al.*, 1996a). Predominance of H-SRB is mainly accredited to kinetic and thermodynamic advantages of H-SRB over H-MPB. It is also concluded that H-SRB need much lower hydrogen threshold concentration than their methanogenic rivals (Lovely, 1985; Oude Elferink *et al.*, 1994; Colleran *et al.*, 1995).

In contrast, there have been few cases in which predominance of H-MPB was reported. Colleran and Pender (2002) found temperature to be affecting the outcome of the competition. They witnessed the predominance of H-SRB at mesophilic temperature (37°C) while H-MPB outcompeted H-SRB at thermophilic temperature (55°C). Strocchi *et al.* (1991, 1994) observed predominance of H-MPB in digestion of human feces at mesophilic temperature (37°C).

2.4.2. Acetotrophic methanogens versus SRB

Both predominance of acetate utilizing SRB (Alphenaar *et al.*, 1993; Stucki *et al.*, 1993; Gupta *et al.*, 1994) and successful competition of acetotrophic methane producing bacteria (Hoeks *et al.*, 1984; Mulder, 1984; Rinzema *et al.*, 1986; Isa *et al.*, 1986a,b;

Polprasert and Haas, 1995; Omil et al., 1996a; Oude Elferink et al., 1994; Colleran et al., 1998; O’Flaherty et al., 1998a; De Smul et al., 1999; Colleran and Pender, 2002) are reported in the literature . Such severe contradictory results from the outcome of the competition between A-SRB and A-MPB have led to different anticipations. Different parameters are suggested by authors that are believed to determine the outcome of competition over acetate:

Feed composition and acetate concentration – According to Polprasert and Haas (1995) there is a direct relation between glucose/acetate ratio and SRB activity expressed as share of COD removal. Omil *et al.* (1996a) observed that higher acetate concentrations favor MPB but it was not practically possible to shift the competition substantially by changing the influent composition.

In the same manner, Yoda *et al.* (1987) reported faster multiplication of MPB in case acetate concentration was above 8 mg/L. In contrast, predominance of A-SRB was reported to be independent of acetate concentration (Oude Elferink *et al.*, 1994).

Sulfate and sulfur concentrations – Obviously sulfate concentration is the limiting parameter for SRB growth, hence dominance of MPB is more likely at low sulfate availability. On the other hand, it is also reported that among different types of SRB, acetate-utilizing SRB are poor competitors for the available sulfate (Laanbroek *et al.*, 1984; Uberoi and Bhattacharya, 1995); thus it is outcompeted by other SRB (non-acetate-utilizing) while available acetate is consequently left for A-MPB. This is the reason why different substrate/sulfate ratios are introduced to govern the competition. Choi and Rim (1991) found that COD/SO₄²⁻ ratio equal to 2.7 is the minimum value which results in predominance of A-MPB; while it is A-SRB that dominates the reactor if the ratio is below 1.7. They also observed an active competition between A-SRB and A-MPB when the COD/SO₄²⁻ ratio is between 1.7 and 2.7. A similar logic is also described by Gerardi (2003) indicating that the substrate/sulfate ratio above 3.0 favors A-MPB while for ratios below 2 they are A-SRB that predominate the system. For ratios in between occurrence of an intensive competition is suggested by Gerardi (2003). However, the term “substrate” used by Gerardi (2003) does not stand for a clear reference such as COD, BOD, VFA, or etc.

Similarly, COD/S ratio is also found to be crucial in the overall process of anaerobic digesters (Isa *et al.*, 1986a, b; Mizuno *et al.*, 1994; Parkin *et al.*, 1990; Vavilin *et al.*, 1994). Reportedly, higher COD/S ratios favor methanogens while at ratios below 10.0 both SRB and MPB activities are inhibited (Parkin *et al.*, 1990; Vavilin *et al.*, 1994).

Iron concentration – High demand of SRB for iron uptake is also reported as a governing parameter (Postgate, 1984) but addition of iron by 2 g/L did not result in any positive progress in SRB activity as reported by Isa *et al.* (1986a, b). However iron can also restrict the bioavailability of sulfur by precipitation of FeS which can in return favor the A-MPB.

Immobilization properties – Isa *et al.* (1986a, b) accredited the predominance of A-MPB to their comparatively better attachment properties. As they reported, weaker immobilization of A-SRB to inert particles as well as sludge granules makes them prone to be washed out. Such a competitive advantage was also reported in continuous flow reactors regardless of total sulfide concentration (Yoda *et al.*, 1987; Koster *et al.*, 1986; Thiele and Zeikus, 1988; Nielsen, 1987; Pichon *et al.*, 1988). In contrast, other studies (Yoda *et al.*, 1987; Alphenaar *et al.*, 1993; Visser *et al.*, 1993d) found similar attachment capacities for both A-SRB and A-MPB in UASB reactors; claiming that it is mainly kinetic growth properties of the bacteria that governs the outcome of the competition.

Type of seed sludge and experimental runtime – Duration of acclimation to high sulfate concentrations is also reported as a factor affecting the outcome of competition between A-SRB and A-MPB (McCartney and Oleszkiewicz, 1991; Harada *et al.*, 1994). According to Visser *et al.* (1993c) it takes about 400 days for A-SRB to increase their share of acetate consumption from 50 to 90% in case acetate is fed into UASB reactors. The corresponding period is found to be 250 days for UASB reactors fed with a VFA mixture (Visser *et al.*, 1993c). Due to such long periods needed for predominance of one species, the initial count of each group seems to be of utmost importance (Visser *et al.*, 1993c). In other words, inoculum used in the startup of an experiment plays an important role in the outcome of competition along with other environmental parameters.

pH – It is known that SRB and MPB have similar optimum pH ranges; 7.3 ~ 6.7 for A-SRB and 6.5 ~ 7.8 for A-MPB (Widdel, 1988; Vogels *et al.*, 1988). However, according to Visser *et al.* (1996) pH values above 7.7 favor A-SRB; while in contrast for pH below 6.9 A-MPB outcompete A-SRB successfully. It should be noted that acidic pH intensifies sulfide toxicity by elevating sulfide concentration. For example pH reduction from 8 to 7 resulted in increase of H₂S concentration from 50 to 240 mg/L which had a considerable effect on the fraction of COD consumed by MPB in a UASB reactor which was fed with a VFA mixture with a COD/SO₄²⁻ equal to 0.5 (Lens *et al.*, 1998).

Temperature – Similar to the optimal pH ranges, SRB and MPB grow in similar temperature ranges and therefore have identical reactions against temperature changes between 10°C and 50°C (Visser *et al.*, 1992). According to a study done by Visser *et al.* (1993b) it was shown that SRB are less sensitive to high-temperature shocks compared to MPB. Also Shin *et al.* (1996) found that reduction of the temperature of a continuous reactor from 35°C to 25°C, in the long term, increases the COD fraction degraded by SRB from 43 to 80%. It can be concluded that temperature shocks may play an important role in alteration of the competition between SRB and MPB.

2.5. Sulfide toxicity (inhibitory behavior)

Sulfide toxicity is mainly believed to be caused by unionized H₂S since it is able to permeate the cell membrane (Schlegel, 1981; Tursman and Cork, 1988). Unionized hydrogen sulfide is toxic to methanogens as well as to sulfate-reducing bacteria. However different studies have found both unionized and total sulfide concentrations important in inhibition of the mentioned groups of microorganisms. According to Koster *et al.* (1986)

unionized sulfide concentration drives the inhibition of acetoclastic methanogenesis in pH range of 6.4 ~7.2 while at higher pH (7.8 ~8.0) the correlation is observed with respect to total sulfide concentration. A similar trend is also introduced by O'Flaherty *et al.* (1998b) suggesting that unionized sulfide concentration is the main cause of inhibition in pH range of 6.8 ~7.2 while for exceeding pH values it is mainly total sulfide that causes the inhibition. However, Hilton and Oleszkiewicz (1990) showed that SRB inhibition correlates with total sulfide concentration while it is only unionized sulfide concentration that affects inhibition of methanogens.

There are varieties of studies suggesting contradictory inhibitory levels of sulfide against different trophic groups. Due to the fact that most of the experiments were performed by addition of sulfide rather than sulfate, the interaction between SRB and non-SRB was completely ignored (Parkin *et al.*, 1990). Additionally many studies do not include records of pH levels making it very difficult to come to trustable conclusions on the inhibition caused by sulfide (Chen *et al.*, 2008). The reported levels of IC₅₀ (median inhibition concentration) for methanogens are 50-125 mg H₂S/L at pH 7~8 (suspended sludge); 250 and 90 mg H₂S/L at pH 6.4 ~ 7.2 of and pH 7.8 ~8, respectively (Parkin *et al.*, 1983; Koster *et al.*, 1986; Oleszkiewicz *et al.*, 1989; McCartney and Oleszkiewicz, 1993; Maillacheruvu *et al.*, 1993; O'Flaherty *et al.*, 1998a). Results from some of the studies about the inhibitory levels of H₂S and total sulfide concentrations towards methanogenesis and sulfate reduction are illustrated in Table 2-2 (on the next page). It is found that fermentative microorganisms are less prone to be affected by sulfide toxicity in comparison with SRB and MPB (McCartney and Oleszkiewicz, 1991; Maillacheruvu *et al.*, 1993). However acetogens and SRB are more or less similarly affected by certain sulfide concentration and are more resistant than MPB (O'Flaherty *et al.*, 1998b).

Acclimatization of MPB to free H₂S was also reported in literature especially in reactors with fixed biomass. According to Isa *et al.* (1986a) acclimated acetotrophic and hydrogenotrophic methanogens were unsubstantially inhibited at concentrations above 1000 mg/L of H₂S.

Table 2-2. Unionized and total sulfide concentrations resulting in a 50% inhibition (IC_{50}) of methanogenesis, sulfate reduction and intermediate substrates (Lens et al., 1998) – reproduced with permission.

Sludge type	Substrate	Temp. (°C)	pH	H ₂ S (mg/L)	Total sulfide (mg/L)	Reference
Methanogenesis						
<i>Sludge suspension</i>	Ace.	35	6.5-7.4	125	NR	Oleszkiewicz et al. (1989)
			7.7-7.9	100	NR	
<i>Sludge suspension</i>	Lac./Ace.	35	7.2-7.6	NR	240	McCartney and Oleszkiewicz (1991)
<i>Sludge suspension</i>	Lac.	35	7.0	100	270	McCartney and Oleszkiewicz (1993)
			8.0	100	1258	
<i>Sludge suspension</i>	Ace.	55	6.3-6.4	18	33	Visser et al. (1993a)
			7.1-7.2	21	78	
			7.9-8.0	24	400	
<i>Sludge granules</i>	Ace.	30	6.4-6.6	246	357	Koster et al. (1986)
			7.0-7.2	252	810	
			7.8-8.0	90	841	
<i>Sludge granules</i>	Ace.	30	7.2-7.4	184	564	Visser et al. (1996)
			8.1-8.3	38	590	
<i>Sludge granules</i>	Ace.	55	6.3-6.4	54	81	Visser et al. (1993a)
			7.1-7.2	75	338	
			7.9-8.0	24	450	
<i>Biofilm</i>	Ace.	35	7.7	>1000	NR	Isa et al. (1986b)
	Ace./Ethnl.		7.3	>1000	NR	
Sulfate reduction						
<i>Desulfovibrio desulfuricans</i>	Lac.	35	7.0	250	500	Okabe et al. (1992)
<i>Sludge suspension</i>	Lac./Ace.	35	7.2-7.6	NR	83	McCartney and Oleszkiewicz (1991)
<i>Sludge suspension</i>	Lac.	35	7.0	>300	NR	McCartney and Oleszkiewicz (1993)
			8.0	185	2244	
<i>Sludge granules</i>	Ace.	30	7.2-7.4	171	615	Visser et al. (1996)
			8.1-8.3	57	1125	
Specific substrates						
<i>Sludge suspension</i>	Prop.	35	6.5-7.4	100	NR	Oleszkiewicz et al. (1989)
			7.7-7.9	60	NR	
<i>Sludge suspension</i>	Buty.	35	6.5-7.4	235	NR	Oleszkiewicz et al. (1989)
			7.7-7.9	>200	NR	
<i>Sludge suspension</i>	Lac.	35	6.5-7.4	320	NR	Oleszkiewicz et al. (1989)
			7.7-7.9	390	NR	
<i>Sludge granules</i>	Prop.	30	7.0-7.5	140	NR	Rinzema and Lettinga (1988b)

Note: NR: Not reported; Ace.: Acetate; Lac.: Lactate; Ethnl: Ethanol; Prop.: Propionate; Buty.: Butyrate

2.6. Reduction of hydrogen sulfide via external agents

2.6.1. Precipitation

Addition of divalent metals such as iron, copper, cobalt and zinc leads to precipitation of dissolved hydrogen sulfide via reaction stated below (Khanal, 2008):

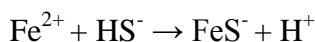

Also Fe (III) also reacts with sulfide forming elemental sulfur and Fe (II), resulting in sulfide removal through the pathway shown below (Wei and Osseo-Asare, 1996):

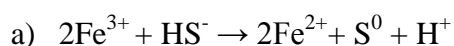

It can be seen that one mole of Fe (III) ion ultimately removes 1.5 moles of sulfide, either as ferrous sulfide or elemental sulfur. It should be mentioned that continuous precipitation of ferrous sulfide in the reactor can increase the total solids (TS) content in the reactor.

2.6.2. Sulfide oxidation

Oxidation of sulfide occurs under aerobic conditions, by means of sulfide-oxidizing aerobic bacteria (Janssen *et al.*, 1997). The product of oxidation depends on the availability of the reactants so that under oxygen limiting conditions (i.e. $[\text{O}_2] < 0.1 \text{ mg/L}$) elemental sulfur is produced while sulfate is the main product under sulfide limiting conditions (Khanal, 2008), as follow:

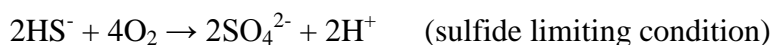

Thiosulfate ($\text{S}_2\text{O}_3^{2-}$) is likely to be produced as well under oxygen limiting conditions (i.e. $[\text{O}_2/\text{S}^{2-}] < 0.5$), through a chemical reaction stated below (Janssen *et al.*, 1995):

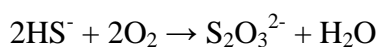

High dosages of oxygen (i.e. $[\text{O}_2/\text{S}^{2-}] > 1.0$) pushes the produced elemental sulfur towards further oxidation and sulfate formation:

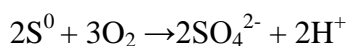

Since elemental sulfur is the desired product of the above stated processes, it is very important to dose sufficient amount of oxygen (neither low nor high) in order to obtain efficient selective sulfide oxidation to elemental sulfur (Khanal, 2008). The optimum molar ratio of oxygen to sulfide is reported to be about 0.7 in order to achieve maximum sulfide oxidation to sulfur (Janssen *et al.*, 1997).

Aerobic conditions can be very toxic to methanogens as a strict anaerobe group of microorganisms (Whitman *et al.*, 2006). However, enhanced methane production and

COD removal under micro-aerobic conditions are also reported (Jagadabhi *et al.*, 2010; Jenicek *et al.*, 2008, 2010) as well as effective sulfide removal (Tartakovsky *et al.*, 2011). Increased hydrolysis rate due to micro-aerobic conditions was suggested to be the reason for better performance of reactor (Tartakovsky *et al.*, 2011).

2.7. Sulfide dissociation

Assuming static conditions in the reactor at the measurement time, it can be said that dissolved hydrogen sulfide (in the reactor) is in an equilibrium with the gas phase. The equilibrium between dissolved free sulfide and the gas phase follows the Henry's law. Henry's constant varies with temperature so that less gas can be dissolved in water at higher temperatures. For hydrogen sulfide various studies are carried out to define its Henry's constant as well as temperature dependency (Lide and Frederikse, 1995; de Bruyn *et al.*, 1995; Dean, 1992; Edwards *et al.*, 1978; Wilhelm *et al.*, 1977). The most repeated result was employed for calculation of dissolved free sulfide concentration according to the concentration measured in the biogas as follows:

$$K_{H(25)}, (\text{Henry's constant at } 25^{\circ}\text{C}) = 0.1, \left[\frac{\text{mol}}{\text{L.atm}} \right], (\text{Wilhelm et al., 1977})$$

$$\frac{-d \ln K_{H(25)}}{d\left(\frac{1}{T}\right)}, (\text{temperature dependency factor}) = 2100, [\text{K}], (\text{Wilhelm et al., 1977})$$

Hence Henry's constant for hydrogen sulfide can be estimated using Eq.1 (Rolf Sander, 1999):

$$K_{H(T)} = K_{H(25)} \times e^{\frac{-d \ln K_{H(25)}}{d\left(\frac{1}{T}\right)} \times \left(\frac{1}{T} - \frac{1}{298.15}\right)}, \left[\frac{\text{mol}}{\text{L.atm}} \right] \quad (\text{Eq.1})$$

$$K_{H(T)} = 0.1 \times e^{2100 \times \left(\frac{1}{T} - \frac{1}{298.15}\right)}, \left[\frac{\text{mol}}{\text{L.atm}} \right]$$

Also non-dimensional form of Henry's constant can be calculated as:

$$K_{H(T)}^{cc} = \frac{C_{aq}}{C_{gas}} = K_{H(T)} \times RT \quad (\text{Eq.2})$$

Where:

T: temperature [$^{\circ}\text{K}$]

R: gas constant, $0.08205746 \frac{\text{L.atm}}{\text{K.mol}}$

C_{aq} : dissolved concentration (mg/L, mol/L ...)

C_{gas} : concentration in gas phase (mg/L, mol/L ...)

pK_{al} for dissociation of hydrogen sulfide in water (i.e. $\text{H}_2\text{S} \leftrightarrow \text{H}^+ + \text{HS}^-$) is a temperature dependent parameter as well. In this study the empirical formula suggested by Hershey *et al.* (1988) was adopted (Eq.3).

$$pK_{a1} = \frac{5765.4}{T} + 15.0455 \ln T - 98.08 \quad (\text{Eq.3})$$

Where:

T: temperature [$^{\circ}K$]

So the concentration of HS^- can be calculated by Eq.4.

$$[HS^-] = [H_2S_{(aq)}] \times 10^{pH - pK_{a1}}, \quad (\text{Eq.4})$$

3. Methodology

3.1. Material and method

3.1.1. Reactors

Two pilot-scale reactors located at Sjölanda wastewater treatment plant (Malmö) were used in the study operated at mesophilic (35°C) and thermophilic (55°C) temperatures. The reactors were equipped with stirrer operated continuously at a constant speed. Feeding substrate and withdrawal of digested matter were done manually once a day at a certain time. The temperature in the reactors was regulated by a thermostat connected to a heater. The digestion chamber was surrounded by a water bath which heated up the reactors. Produced biogas was collected in a bell-shape gas collector filled with water. Change in the water level inside the gas bells represented the differential pressure of the produced biogas. Schematic drawing of the reactors is shown in Figure 3-1. For operational parameters of the reactors refer to Table 3-1.

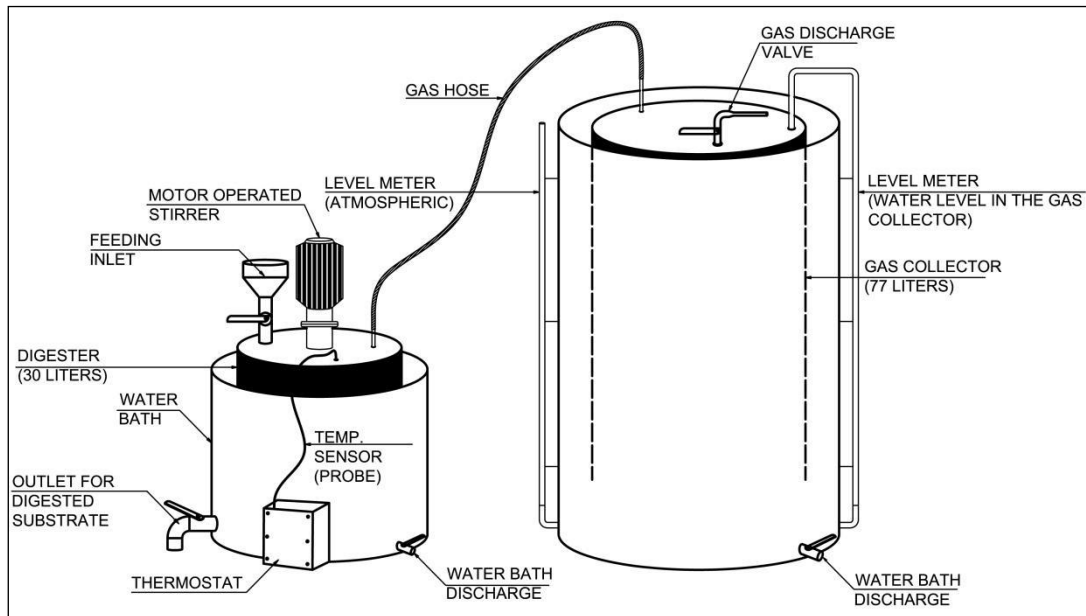

Figure 3-1. Schematic of the pilot-scale reactors used in the experiment (see Appendix V for an enlarged view).

Table 3-1. Operational characteristics of the reactors.

Reactor	Sludge Volume (Liters)	Temperature (°C)	SRT (days)
55TH20	20	55	10
35MS20	20	35	10

3.1.2. Analyses and measurements

Some parameters of the digestion process as well as operational characteristics were measured in-situ at the location of pilot-scale reactors. pH of the digested matter from the

reactors was measured using a digital pH-meter (pH 3110 SET 2 incl. SenTiz® 41) calibrated based on a two point-calibration at pH levels of 4 and 7. Gas fractions – including methane, carbon dioxide, oxygen and hydrogen sulfide (up to 2000 ppm) - were measured using a portable gas-meter SEWERIN SR2-DO. For higher hydrogen sulfide contents (above 2000 ppm), Dräger tube *Hydrogen Sulfide 0.2%/A* with order code of CH28101 was employed (range from 0.2 vol.-% to 7 vol.-%.)

Samples of digested matter as well as substrate were taken to the laboratories at Chemical Engineering Department / Lund University for further analyses. HACH LANGE test tubes were used for measuring COD (LCK 114), ammonium (LCK 303), sulfate (LCK 153), iron (LCK 320), and phosphate (LCK 049). Prepared tubes were analyzed with HACH LANGE spectrophotometer (model DR 2800).

All the samples stated above were centrifuged for 15 minutes at the speed of 10000 rpm and filtrated through *Munktell* general purpose filter papers with 6~10µm pore size before further analysis.

Furthermore, TS content of digested matter and the substrate were measured after samples were dried for 24 hours at 105°C. VS content was estimated after burning the samples at 550°C in 2 hours (SIS, 2000).

Methane production in lab-scale batch reactors was measured with gas-chromatograph - Varian 3800 Gas Chromatograph- equipped with TCD (thermal conductivity detector) and a column with the dimensions: 2.0m x 1/8 inch x 2.0mm. Volatile fatty acids (VFA) content of samples were analyzed with gas-chromatography using Agilent 6850 Series GC System equipped with FID (flame ionization detector) and a column with the dimensions: 25m x 0.32µm x 0.5µm.

3.1.3. Inoculation

The inoculum for the mesophilic reactor was taken from Öresundsverket WWTP/BGP (operated at 35°C) and the thermophilic inoculum was collected from Kävlinge WWTP/BGP (operated at 55°C). The analysis data on the inoculum is presented in Table 3-2.

Table 3-2. Operational characteristics of the reactors.

Reactor	COD (mg/L)	NH ₄ ⁺ -N (mg/L)	SO ₄ ²⁻ (mg/L)	Fe ²⁺ /Fe ³⁺ (mg/L)	PO ₄ ³⁻	pH	Acetate (mg COD/L)	Propionate (mg COD/L)	TS	VS
Thermophilic inoculum	845	740	55	10.78/6.10	15	8.1	30	< 20	1.53%	0.97%
Mesophilic inoculum	680	485	40	12.42/3.90	90	7.6	< 20	< 20	2.32%	1.66%

3.1.4. Substrate

Needed algae for the experiment were collected at Skåre harbor, approximately 7 kilometers west of Trelleborg, southern Skåne – Sweden. Collected algal mass consisted of various species such as *fucus vesiculosus*, *fucus serratus*, *furcellaria lumbricalis*, *polysiphonia sp.*, *ceramium sp.* and *zostera marina* (not classified as algae) (Figure 3-2).

Mixture of algae had a TS of 15-25% from which between 75-80% was measured as VS fraction, depending on the moisture content of the batch.

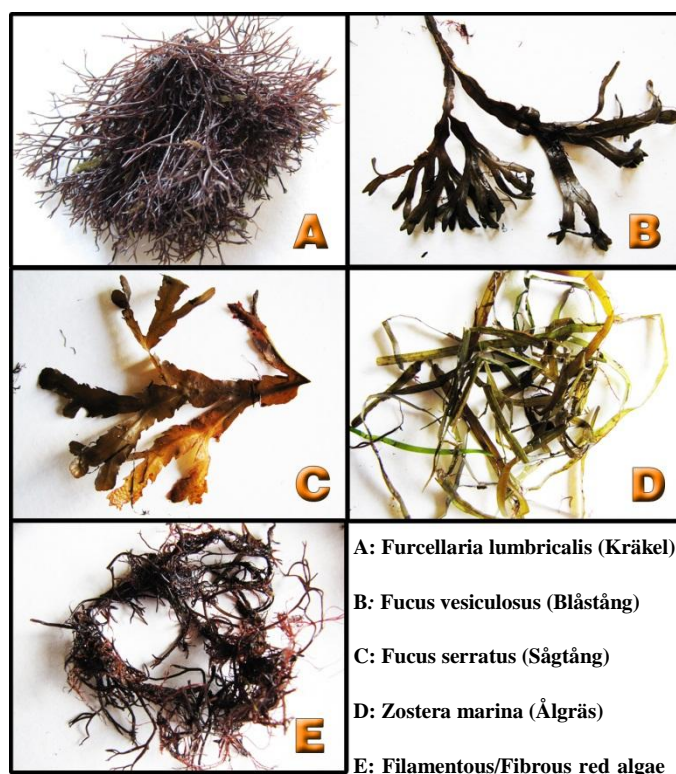

Figure 3-2. Different species of algae included in the experiment.

3.2. Pretreatment

As mentioned in previous sections, alga is considered as a difficult substrate to be employed in continuous digestion due to its physical characteristics. The most important task in preparation of algal substrate is to make it appropriate to be fed into the digesters. Two different techniques were tested in this study to obtain free-flowing algal substrate – cutting algae into small pieces and enzymatic pretreatment.

3.2.1. Cutting algae

Various tools were employed to grind the algae to smaller particles. Food grinder, kitchen grinder and hand blender were all tested for cutting. Unfortunately none of the above could achieve the goal due to severe blade jam. Ultimately, algae were manually chopped into pieces of less than 3 cm-long in order to make feeding possible (Figure 3-3) using knives and cutting-boards. 400 g of chopped algae was diluted up to 1330 ml to maintain loading rate of 3 kgVS/day·m³. During the operation it was realized that the amount of water would not be sufficient to force the algae into the reactor. Hence it was decided to half the loading rate down to 1.5 kgVS/day·m³.

Consequently 200 g of cut algae was to be diluted up to 1330 ml mixture as substrate. However, physical characteristics of algae made it almost impossible to feed the reactors with chopped algae without any air contamination risk. Aeration of reactors, even at micro levels, could manipulate the study due to the fact that micro-aeration leads to

oxidation of sulfide to sulfate/elemental sulfur, as described previously. Consequently the chopping technique was abandoned.



Figure 3-3. Cutting algae into small pieces.

3.2.2. Enzymatic pretreatment

Enzymatic pretreatment of marine algae was carried out using *Cellic® CTec2*. *Cellic CTec2* enzyme converts cellulose and hemicellulose, containing polymeric forms of sugar, into hydrolyzed fermentable monomers (Novozyme, 2010). According to Novozyme (2010) peak performance of the enzyme is obtained at 45~50°C and pH 5~5.5 as shown in Figure 3-4.

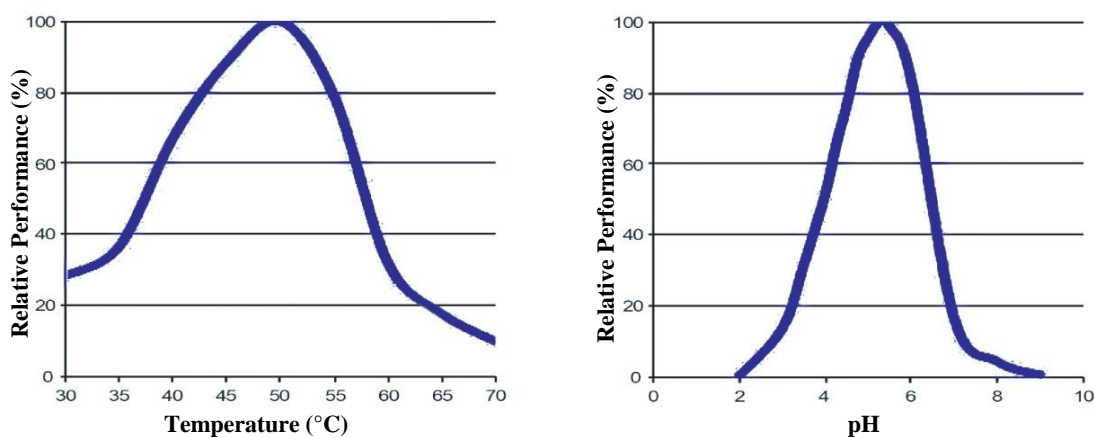

Figure 3-4. Relative performance of *Cellic® CTec2* versus temperature and pH variations (Novozyme, 2010).

Pretreatment of marine algae using *Cellic CTec2* was tested in lab-scale before pilot-scale implementation. The algae were kept at $-25\pm 2^{\circ}\text{C}$ before pretreatment experiment. Lab-scale batches were consisted of a 2-liter glass reactor, stirrer (mixer), and water bath for regulating the temperature at 45°C , as seen in Figure 3-5. Four reactors were set up at 45°C and loaded with 450 g of frozen algae diluted up to 1500 ml with tap water, in order to evaluate the enzyme's effect on algal mass. The activity analysis of enzyme showed activity of 97 FPU/g as well as 274 g/l of sugar (glucose) as stabilizing agent. Dosages of enzyme were added proportional to total dry solids content of the algae as 13.5, 26.95, 40.41 FPU/gTS. One of the reactors ran without any enzyme dosed in order to study the temperature effect on hydrolysis of algae (as reference).

Lab-scale pretreatment was carried out for 5 days and the content was sieved through 4 mm-pore sieve in order to obtain a homogenous substrate after being diluted back to 1500 ml volume to compensate the evaporation effect. The in-hand substrate was later used to evaluate methane potential at mesophilic (37°C) and thermophilic (55°C) temperatures via lab-scale anaerobic batch reactors (2-liter glass bottles) as shown in Figure 3-6.

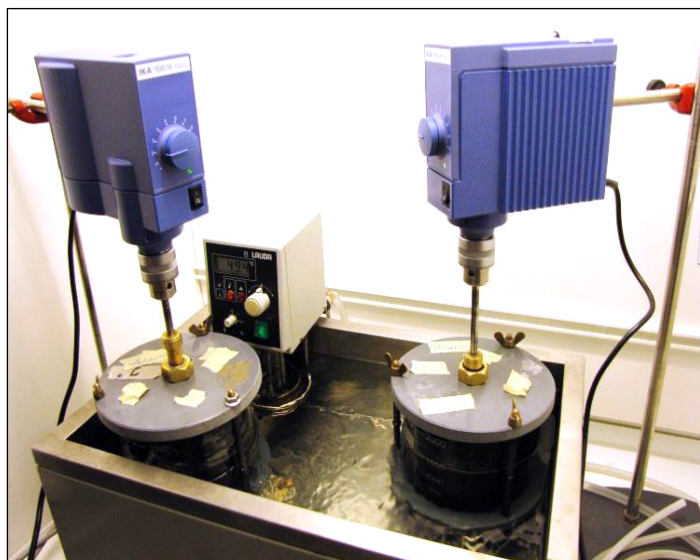

Figure 3-5. Batch reactors used for lab-scale enzymatic pretreatment of algae.



Figure 3-6. 2-liter batch bottles with air-tight rubber septum.

Pilot-scale pretreatment of algae using enzyme was carried out in a larger tank as shown in Figure 3-7 at about 50°C . The pretreatment reactor is heated by a water-bath while the temperature is regulated by a thermostat. Unfortunately the stirrer of the reactor stopped working in the first day of full-scale pretreatment due to heavy load of added algae. Preparation process of pretreated substrate was same as mentioned in lab-scale experiment.



Figure 3-7. Pretreatment reactor used in full-scale experiment (Volume = 170 liters).

3.3. Micro-aeration method

In order to create micro-aerated conditions in the reactor in order to enable the aerobic sulfide oxidizers to grow addition of air into the reactor (not the gas collector) is needed. For this reason the hose connecting the reactor to the gas collector was chosen for injection. Compressed air by means of a pump and an airtight tube with a manometer (Figure 3-8: used for dissolved air floatation method's demonstration) was injected in the hose while the hose was clamped on the side towards gas collector (Figure 3-9). Clamping the hose prevents the air flow into the gas bell so that the injected air will be present in the bio-reactor.

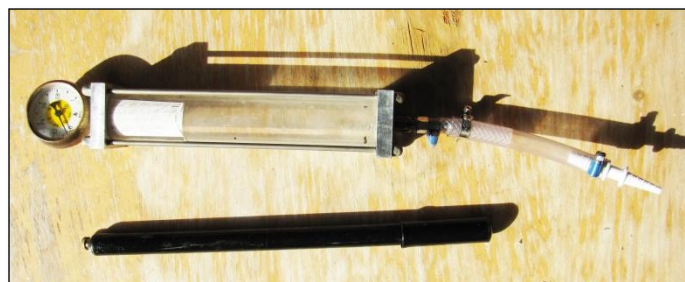

Figure 3-8. Pump and the airtight tube used for compression of air.

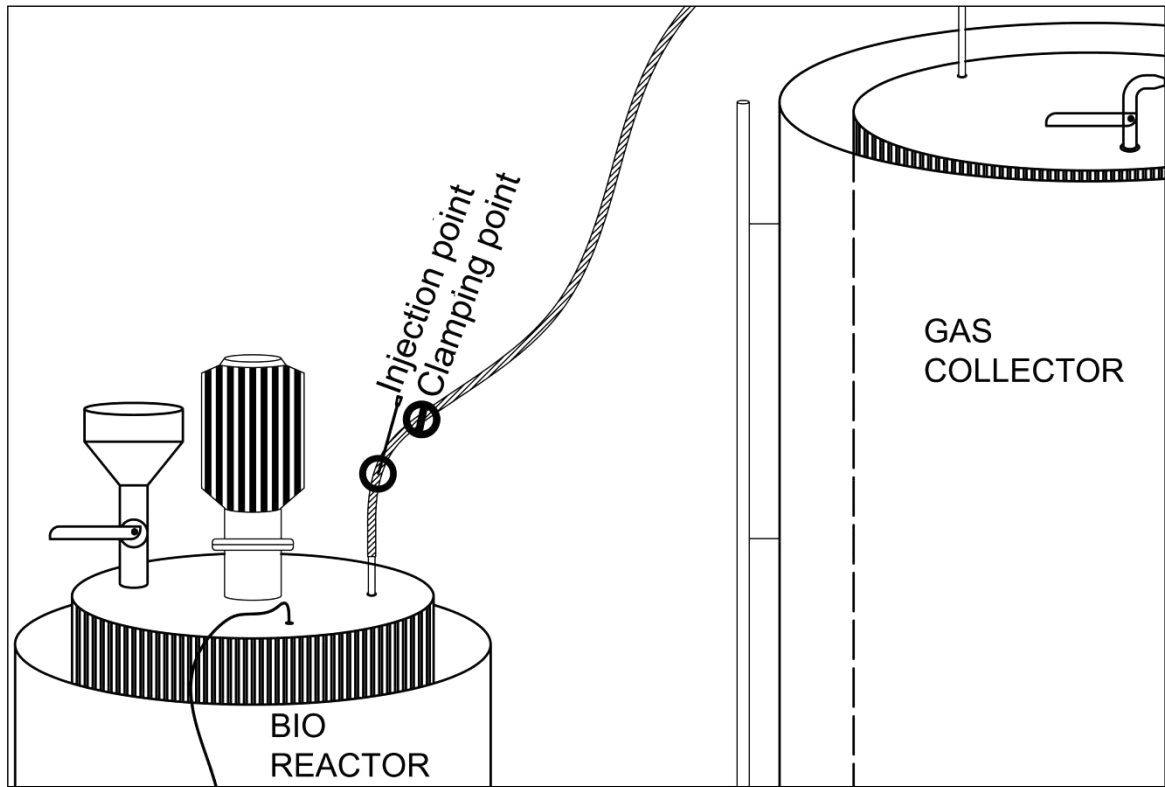

Figure 3-9. The hose connecting the digester to the gas collector was used for injection of air. The way towards gas collector was clogged using a clamp to prevent airflow into the gas collector.

4. Results and discussions

4.1. Enzymatic pretreatment of algae (lab-scale)

Frozen algae were used for evaluation of enzymatic pretreatment in a lab-scale experiment as described in section 3.2.2. Distilled water was added into the reactors after pretreatment ended in order to compensate the effect of evaporation; afterwards the content was sieved through 4 mm pore size sieve in order to obtain a homogenous matter. The results from the experiment (after 5 days of pretreatment) are presented in Table 4-1.

Table 4-1. Results from lab-scale enzymatic pretreatment of algal mass after being sieved.

Reactor	Added enzyme (FPU/g TS)	NH ₄ ⁺ -N (mg/L)	SO ₄ ²⁻ (mg/L)	Acetate (mg /L) as COD	Propionate (mg /L) as COD	pH	SCOD* (mg/L)	TCOD* (mg/L)	TS (%)	VS (%)
0Enz5	0	125	1330	30	<20	8.5	4200	13000	1.6	0.7
15Enz5	13.5	81	830	1700	<20	5.1	10000	26000	2.8	1.9
30Enz5	26.95	81	626	1200	<20	4.2	10000	26000	4.4	3.0
45Enz5	40.41	84	318	550	<20	4.3	10000	31000	4.8	3.5

*Effect of the enzyme with approximately 700 gCOD/L_{enzyme} is excluded in the results

According to the results, higher dosages of enzyme have positive impacts on TS and VS content while a certain amount of COD and ammonium is obtained at all cases. Surprisingly it can be observed that less sulfate is present in the reactors with higher dosages of enzyme. The same trend can be seen for acetate as well. Similar decreasing trends for sulfate and acetate can probably be a sign for presence of A-SRB utilizing both substrates to produce hydrogen sulfide. This has to be investigated furthermore because no anaerobic conditions were guaranteed during the experiment.

In order to evaluate the salinity of pretreated algae (with enzyme), electric conductivity of the slurry was measured (data not shown). According to a conversion table provided by Stockholm University (Baltic Nest Institute – see References for the link), salinity of samples varied between 9 to 11 mS/cm which corresponds to the range 6 to 7 practical salinity units (PSU).

Enzymatic pretreatment will probably help the digestion towards predominance of MPB via higher COD/sulfate ratio, which is believed to be a key parameter in governing the competition between MPB and SRB.

As mentioned previously, the substrate from enzymatic pretreatment was then digested in batch experiment at mesophilic (37°C) and thermophilic (55°) temperatures according to the method for estimation of biomethane potential (BMP) suggested by Hansen *et al.* (2004). Lab-scale batch digestion went on for approximately 50 days and the resulting methane yields are presented as Figures 4-1 and 4-2. The results of the experiment suggest very low net methane potential for both mesophilic digestion (12 Nml/gVS_{in}) and thermophilic (101.5 Nml/gVS_{in}) in comparison with municipal sewage sludge which normally gives yields around 400 Nml/gVS_{in} (Davidsson, 2007). It should be noted that the yield values mentioned above are net values exclusive of the yield contributed by the

added enzyme and of the inoculum (refer to Appendix I for calculations of theoretical methane yield of added enzyme).

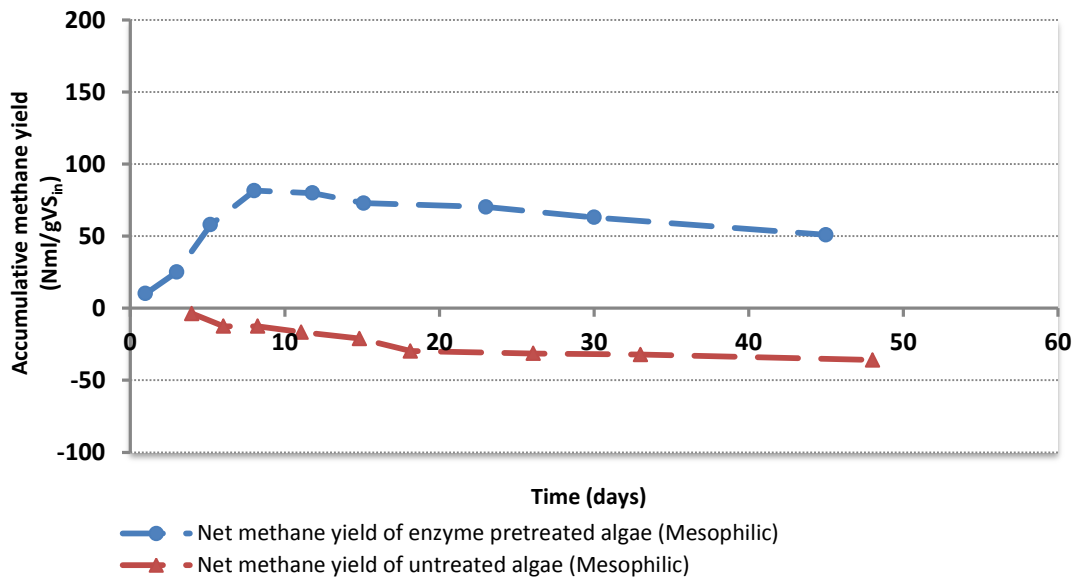

Figure 4-1. Accumulative methane production from mesophilic batch experiment (the enzyme pretreated algae comes from 30Enz5 reactor). About 40 Nml/gVS_{in} of the found methane potential is contributed by the added enzyme.

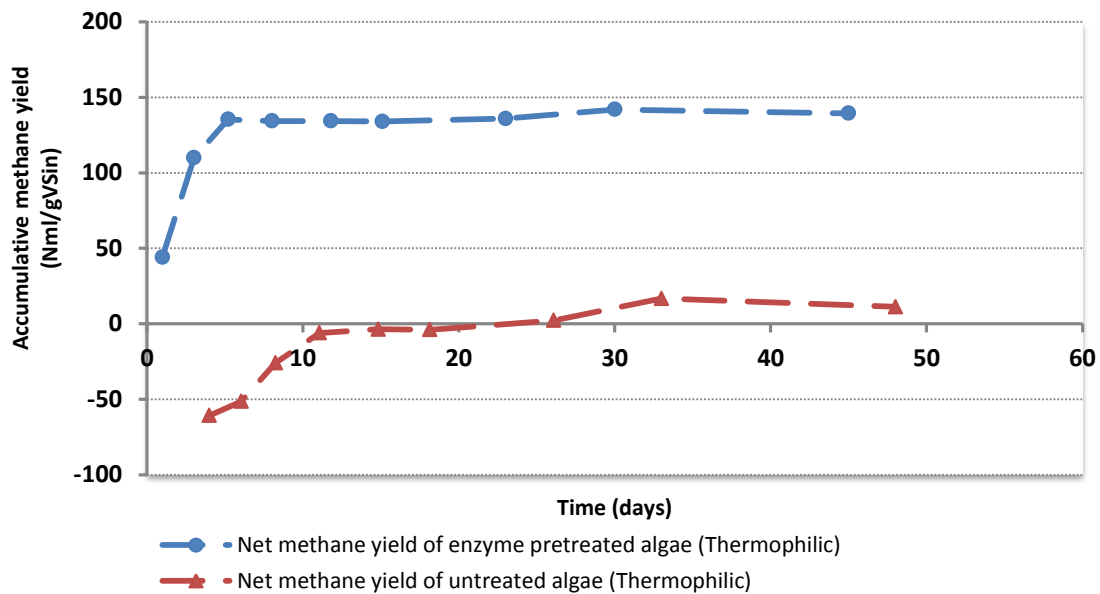

Figure 4-2. Accumulative methane production from thermophilic batch experiment (the enzyme pretreated algae comes from 45Enz5 reactor). About 40 Nml/gVS_{in} of the found methane potential is contributed by the added enzyme.

Observations as presented in figures above, demonstrate the presence of strong inhibitory agent in the substrates. As it can be noticed in Figure 4-1, no considerable methane yield is found at mesophilic digestion of enzyme pretreated algae and the process was inhibited after 8 days of digestion when the yield reaches 82 Nml/gVS_{in}.

Digestion of untreated algae at mesophilic temperature was inhibited constantly leading to the methane potential of $-36 \text{ Nml/gVS}_{\text{in}}$. This illustrates stronger inhibitory effect of the inhibition source in the untreated substrate.

At thermophilic batch digestion of enzyme pretreated algae, maximum yield is observed after 5 days of digestion about $135 \text{ Nml/gVS}_{\text{in}}$ (Figure 4-2). Digestion of untreated algae at thermophilic temperature was also inhibited in the start of the process but later on showed a tendency for recovery as positive yields – although very small – were obtained.

Several sources can be mentioned for the reason for the observed inhibitions stated above. Sulfide can be the cause of inhibition since the amount of sulfate released into the reactor without any enzymes is much higher while sulfate concentration decreases at higher dosages of enzyme (see Table 4-1). Hence, considering the COD/SO_4^{-2} of lab-scale pretreatment and the substrate added to mesophilic and thermophilic batches, sulfide can potentially be the source of inhibition. However not so fast inhibitory effect is expected from sulfide – as observed in mesophilic digestion of untreated algae - due to the fact that no sulfide generation was observed in the reactors which the inoculum were taken from. This means that not considerable counts of SRB were already available in the inoculum in order to generate hydrogen sulfide immediately.

Salinity of the substrate (i.e. Na^+) can also be a source of inhibition (Soto *et al.*, 1991). Different values for sodium concentration, ranging from 3.5 to 53 g/L, are reported in the literature – depending on acclimatization period, substrate and digestion properties - leading to inhibition of methanogenesis (Chen *et al.*, 2008). Assuming that the salinity of substrate is the source of inhibition in this experiment, our observations will be in contrast with the literature which report higher sensitivity of thermophilic digestion to salinity (Soto *et al.*, 1991, 1992). Accordingly, severe inhibition observed in mesophilic digestion would decrease the reliability of the hypothesis.

Reportedly, different derivatives of lignin, specifically aldehyde groups and those with apolar side chain, can be highly toxic to methanogens (Benjamin *et al.*, 1984; Sierra-Alvarez and Lettinga, 1991; Chen *et al.*, 2008). Presence of true lignin cells in a specific species of red algae - *Calliarthron cheilosporioides* – was reported by Martone *et al.* (2009) for the first time. Although there is a chance that lignin causes the inhibition; lack of data regarding cellular structure of the digested algae as well as degradability of lignin by means of the employed enzyme, makes it impossible to draw reliable conclusions.

Nevertheless analyses of reactors' content after digestion period of about 60 days indicate no inhibition of acetotrophic groups due to thorough VFA consumption in the batches with untreated frozen algae (see Table 4-2).

Table 4-2. Chemi-physical properties of the batch content after 60 days of digestion.

Reactor	pH	Decreased VS (g)	Conductivity (mS/cm)	Ammonium (mg-N/L)	Sulfate (mg/L)	Acetate (mg COD/L)	Propionate (mg COD/L)
Mesophilic – PTA	7.22	6.86±0.22	9.82	927.5	77.2	< 20	< 20
Mesophilic Unpretreated	- 7.51	2.03±0.19	8.92	877.5	55.7	< 20	< 20
Thermophilic – PTA	7.36	4.75±1.46	8.24	762.5	82	< 20	< 20
Thermophilic Unpretreated	- 7.76	1.50±0.12	7.36	680.0	53.4	< 20	< 20

In order to justify the phenomenon, two different speculations presented below may be considered:

- a) SRB outcompeted methanogens in competition over acetate due to higher amounts of sulfate released from un-pretreated algae-i.e. lower COD/SO₄²⁻ ratio (see Table 3-1). On the other hand due to the fact that the methane yield in mesophilic reactor is negative could be another argument for the hypothesis. This could be in agreement with Shin *et al.* (1996) who demonstrated that at lower temperatures the amount of COD degraded by SRB increases. However it is not possible to verify the hypothesis since no hydrogen sulfide production was measured in the batches.
- b) Hydrolysis is reported to be the limiting step in anaerobic digestion. It seems very probable that the un-pretreated frozen algae have not been hydrolyzed sufficiently. Ocular examination of digestates from the batches also proved that not much was happened to the structure of the fed algae. Therefore it could be speculated that insufficient hydrolysis of algal mass (perhaps due to protective membranes) may have led to very low methane yield in thermophilic and negative yield for mesophilic batches.

4.2. Enzymatic pretreatment of algae (pilot-scale)

Two full-scale batches of enzymatic pretreatment were done in order to provide the substrate for the entire experiment. Enzyme dosage equal to 15 FPU/gTS was selected to be implemented in the full-scale experiment. The amount water (tap water) added was maintained about 2.29 L_{water}/kg_{algae} in both batches. The amount of water was selected based on the average proportions from lab-scale experiment stated in previous section. The pretreatment continued for 9 days for batch No. 1 and 5 days for batch No. 2. However extension of pretreatment period did not lead to further substantial degradation of algal matter (see Figure 4-3).

Comparing the results from lab-scale experiment with those from pilot-scale, revealed that lack of stirrer in the full scale experiment has led to lower TS, VS, and SCOD (compare Tables 4-1 and 4-3 for 15Enz5 and 1-2012/03/24) in spite of higher pretreatment temperature and longer retention time.

Better degradation of second batch (2-2012/04/19) can be accredited to the initial physical conditions of the collected algae. The analyses show about 70% higher VS content and

20% dissolved COD from the pretreatment of the 2nd batch in comparison with the first batch despite of lower enzyme dosage. The reason for the mentioned difference can probably be found in the qualities of collected algae.

The algae pretreated in the first batch were collected on 14th February 2012 at Skåre harbor at about -5°C. The algae looked very fresh and sound with an intact structure so that it was simply possible to separate and identify different species. In contrast, second batch was collected in warmer period (17th April 2012) when the temperature was about +7°C. As the quality difference in batches can be noticed in Figure 3-4, the second batch seemed to be partly hydrolyzed and fragile with a damaged structure.

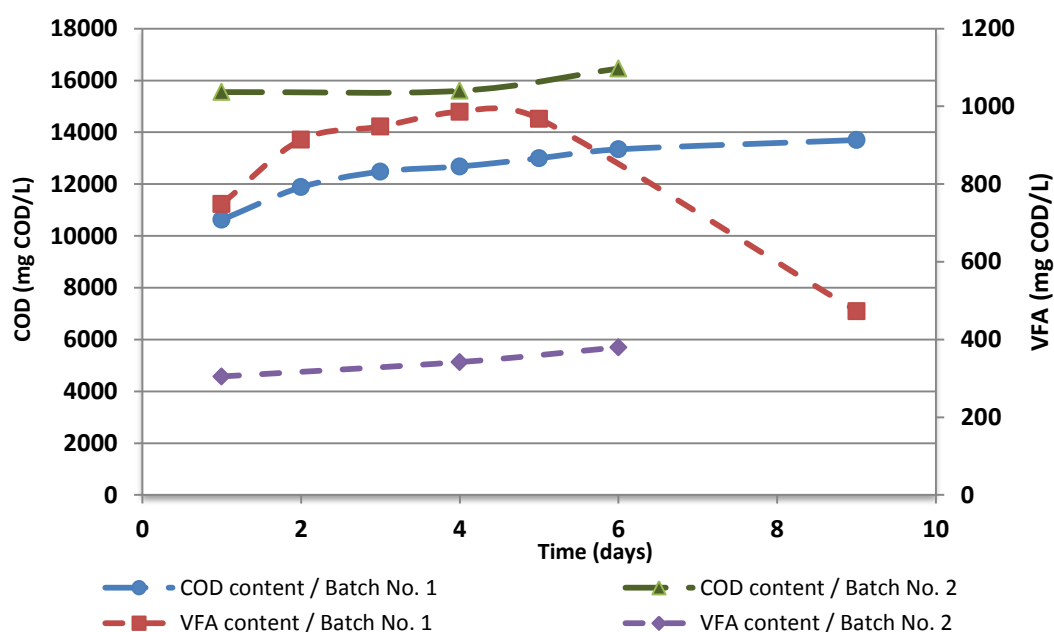

Figure 4-3. COD and VFA variations during enzymatic pretreatment (Batches No.1 and 2). The drop in the VFA content of the Batch No. 1 after the 5th day of pretreatment is due to some degradation because of formation of anaerobic conditions in the pretreatment reactor (no mixing was present).

Although collection of hydrolyzed algae (2nd batch) was very difficult and time consuming – not much could be hunted using garden rake and basket – the pretreatment process was done more conveniently. During pretreatment of 2nd batch, manual stirring (mixing) of the pretreatment reactor was much easier as well as no unpleasant odor was emitted, and no floatation of algae on the surface occurred. The odor problem was so severe in the first pretreated batch that it caused extreme inconveniences during the operation.

Table 4-3. Results from pilot-scale enzymatic pretreatment of algal mass.

Batch date	Batch No. -	Added enzyme (FPU/g TS)	Mean NH ₄ ⁺ -N (mg/L)	Mean SO ₄ ²⁻ (mg/L)	Mean Acetate (mg/L) as COD	Mean Propionate (mg/L) as COD	pH	SCOD (mg/L)	TS (%)	VS (%)
1 – 2012/03/24		13.5	119	815	437	38	6.25	13580	1.6	0.9
2 – 2012/04/19		11.1	82.5	1310	320	34	3.95	16440	2.32	1.54

However as the outcome of a mass balance of the 2nd pretreatment batch it was found that about 38% of the solid content of the collected algae was available in the prepared substrate (sieved through 4 mm sieve) thanks to the physical weakness of the collected mass.



Figure 44-4. Physical difference in quality of batches of algae collected for the experiment (Left: collected on 2012/02/14 (1st batch); Right: collected on 2012/04/17 (2nd batch)).

4.3. Continuous digestion of pretreated algae

Two digesters set at mesophilic (35°C) and thermophilic (55°C) temperatures were inoculated and fed with 2 liters of enzyme pretreated algae on daily basis. Loading rate of the reactors varied during the experiment as shown in the timeline of the continuous experiment (Figure 4-5). During the first week, only 1 liter substrate was fed per reactor (i.e. SRT = 20 days) but from day no. 8 until the end of experiment 2 liters per day was fed continuously (i.e. SRT = 10 days). It should be noted that neither of the reactors were fed on day 23 in order to ease off the occurred inhibition (discussed later). From day 23 on, OLR increased up to around 1.6 Kg VS/m³·day due to better pretreatment results obtained from batch no. 2.

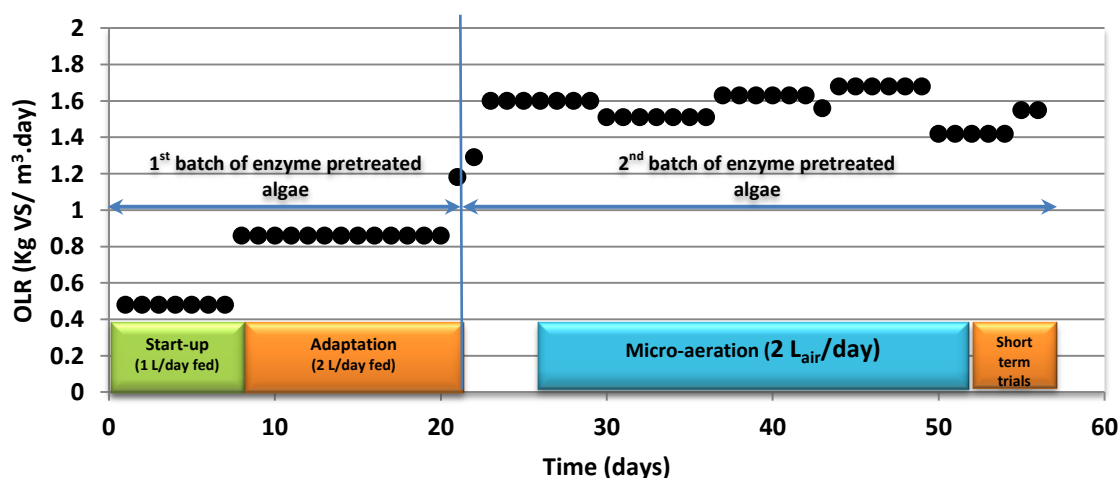

Figure 4-5. Changes in the organic loading rate as well as the timeline of the continuous digestion.

Disregarding the data from first 10 days, temperatures of the reactors were maintained throughout the experiment at 36.01 ± 0.49 (°C) and 55.05 ± 0.71 (°C) for mesophilic and thermophilic reactors, respectively (Figure 4-6). As it can be noticed the temperature in thermophilic reactor was increased by about 5 degrees from 50 to about 55°C during the first 10 days in order to acclimatize the microorganism to the new digestion conditions.

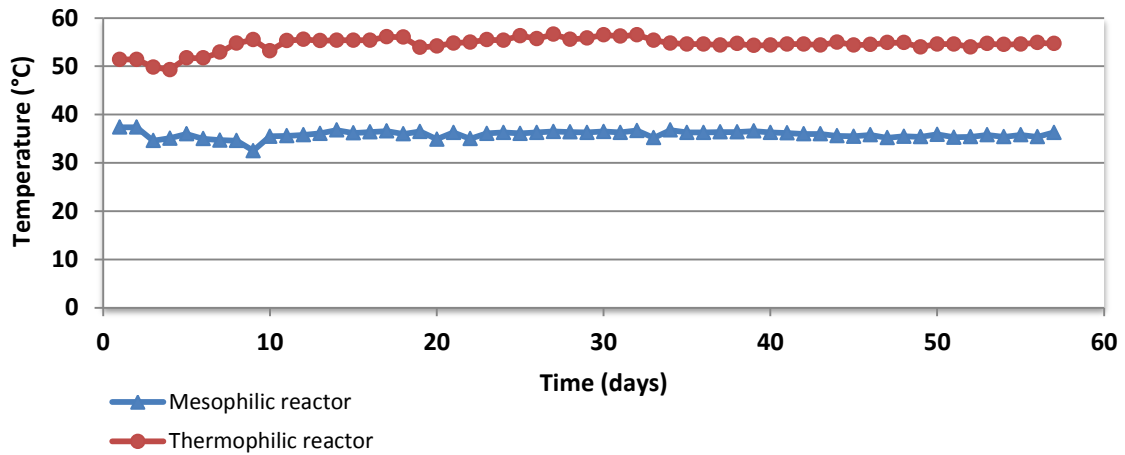

Figure 4-6. Thermal stability of reactors during the experiment.

4.3.1. Initiation of inhibition (day 1 to 25)

Furthermore, methane production reached about 7 NL/day after 10 days of inoculation in both reactors (see Figure 4-7). The thermophilic reactor produced slightly lower methane in comparison with the mesophilic one. Haghghatafshar *et al.* (2012) also reported lower gas production in thermophilic digesters. The low gas production may be a result of maladaptation of thermophilic methanogens, temperature stability and etc. However, it is not reasonable to draw conclusions due to the fact that none of the reactors reached stable conditions regarding VFA levels before inhibition (see Figure 4-12).

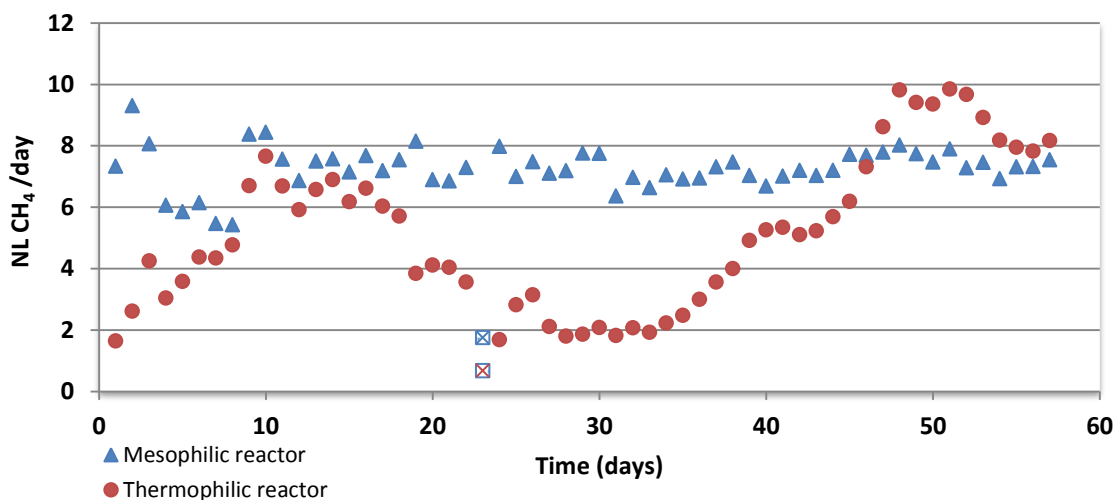

Figure 4-7. Methane production rate throughout the experiment (note that change in OLR is not taken into account) – The digesters were not fed on day 23(indicated as crossed boxes on the graph).

In order to better understand the process in the reactors it is needed to normalize the gas production against OLR. Figure 3-8 illustrates the normalized methane production per day per gram of VS_{fed} . As measured, the methane yield levels out at about 400 NmL/gVS_{fed} for a very short period (about 7 to 10 days) before the digestion is inhibited due to high hydrogen sulfide concentration on days 18 and 22 in thermophilic and mesophilic reactors respectively.

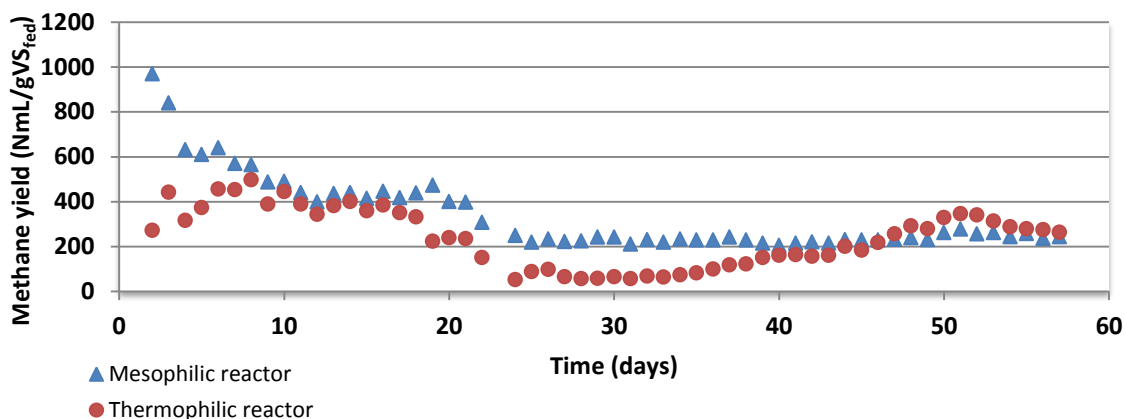

Figure 4-8. Methane yield as NmL/gVS_{fed} for thermophilic and mesophilic reactors.

Sulfide is produced by a specific group of microorganisms called Sulfate reducing bacteria (SRB) that use sulfate and acetogenesis products as substrate. Observations indicate that SRB are able to grow very fast so that after about two weeks since the start of experiment the concentration of hydrogen sulfide in the produced biogas exceeded 10000 ppm. Figure 4-9 illustrates the equivalent volume of the hydrogen sulfide gas as NmL produced per day.

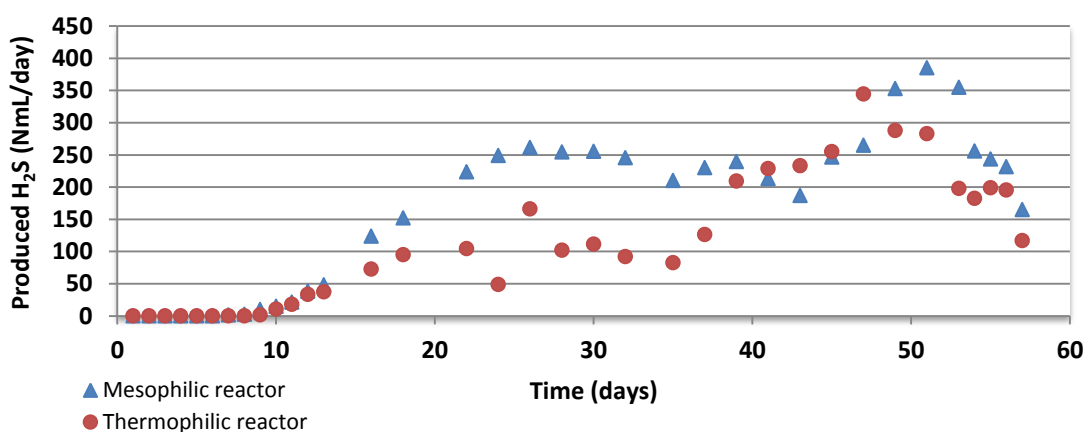

Figure 4-9. H_2S production throughout the experiment.

Despite of low solubility of sulfide in thermophilic reactor, due to higher temperature, the amount of sulfide produced in the gas phase was much lower than in the mesophilic reactor. However, analyses for sulfate concentration in the reactors did not leave any reliable results to be used as an argument here although it could be seen that the concentrations are very low in both reactors. It is anticipated that measurement of sulfate

using HACH LANGE test tubes (LCK 153) is very uncertain for samples with low sulfate content (i.e. no dilution is needed) since the results are strongly affected by the natural color and turbidity of samples. Figure a-1 in Appendix IV shows the variation of sulfate concentration in the thermophilic reactor whereas no reasonable results were found for the mesophilic reactor due to high turbidity of the centrifuged/filtrated sample.

However, studying the sulfide generation only reveals that SRB are more efficient in mesophilic in comparison with thermophilic conditions. This is naturally in contrast with higher methane production in mesophilic reactor since the amount of COD consumed by SRB is higher. This contradiction could be justified by studying the TS/VS reduction performance of reactors. However, since no steady-state was achieved in either of reactors it was not possible to draw reasonable speculations over the solids reduction potential of the reactors (Figure 4-10).

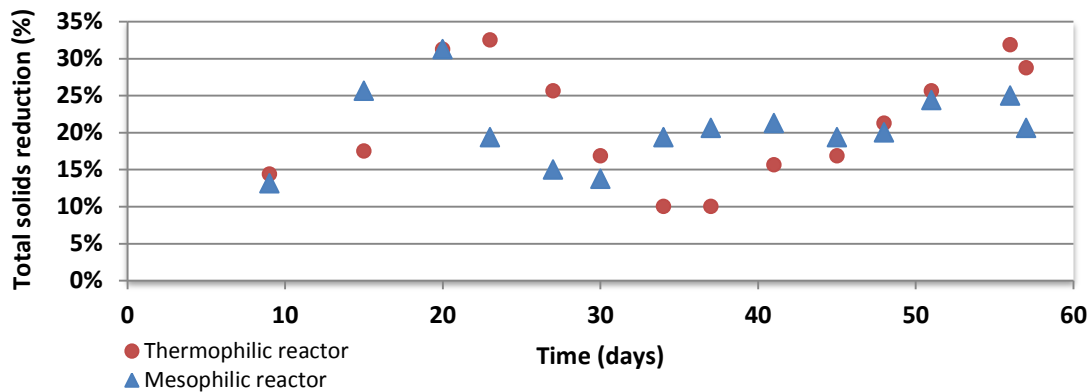

Figure 4-10. Total solids reduction in the reactors presented as percentage. Solids reduction increases in the beginning of the process but later –from day 20 on- tends to decrease. Based on the recorded data it is not viable to differentiate either the decrease is due to sulfide inhibition of hydrolytic bacteria or increased TS of fed substrate (refer to Table 4-2 and Figure 4-6).

Sulfide inhibition is believed to be due to high concentrations of free hydrogen sulfide (dissolved unionized form of sulfide). The concentration of unionized hydrogen sulfide in the reactor was calculated based on Henry’s law and presented in Figure 4-11 below.

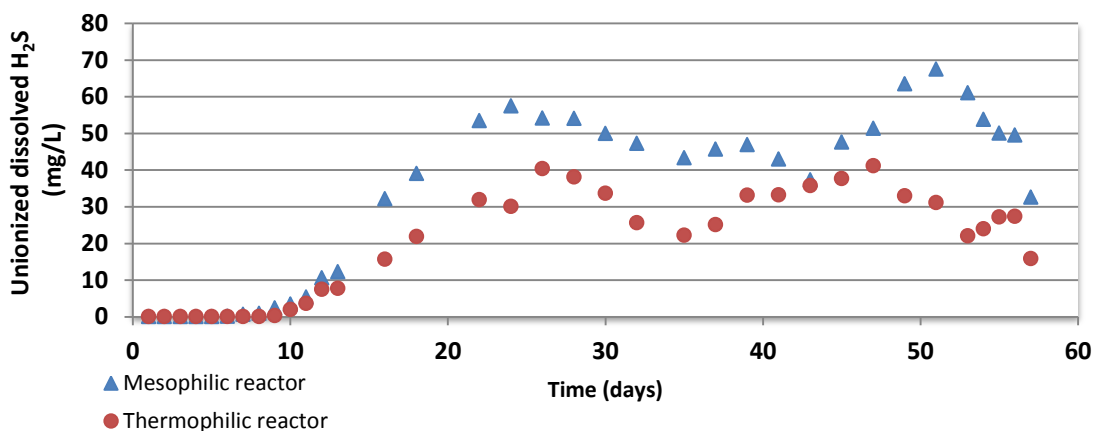

Figure 4-11 Concentration of unionized H_2S in the reactor calculated based on Henry's law assuming stable (static) conditions in the reactor. The inhibition occurred at 50 mg/L of unionized sulfide in the mesophilic reactor while it was around 22 mg/L in the thermophilic reactor.

Considering the data on methane yield (presented in Figure 4-8) it can be noticed that the major inhibition in the thermophilic reactor has occurred on day 18 while the significant drop in methane yield of the mesophilic reactor occurred a few days later on day 21 corresponding to about 22 mg/L (10000 ppm in gas phase) and 50 mg/L (17000 ppm in gas phase) of unionized dissolved sulfide, respectively. Earlier inhibition of methanogens in the thermophilic reactor, in spite of its lower sulfide content, demonstrates that methanogens are more prone to sulfide inhibition at thermophilic temperatures. However, stronger resistance of mesophilic reactor against higher sulfide concentrations can also be a sign of acclimatization of the methanogens to high sulfide levels. This is very likely to be the reason in this case, since the inoculum for mesophilic reactor was taken from Öresundsverket which have had relatively high hydrogen sulfide content in the produced biogas for a long period of time.

The change in the VFA concentrations of the reactors also shows that acetate is accumulated in the thermophilic reactor since the 15th day of the experiment (Figure 4-12(a)) reaching slightly over 3500 mg COD/L. However, no acetate is accumulated in the mesophilic reactor.

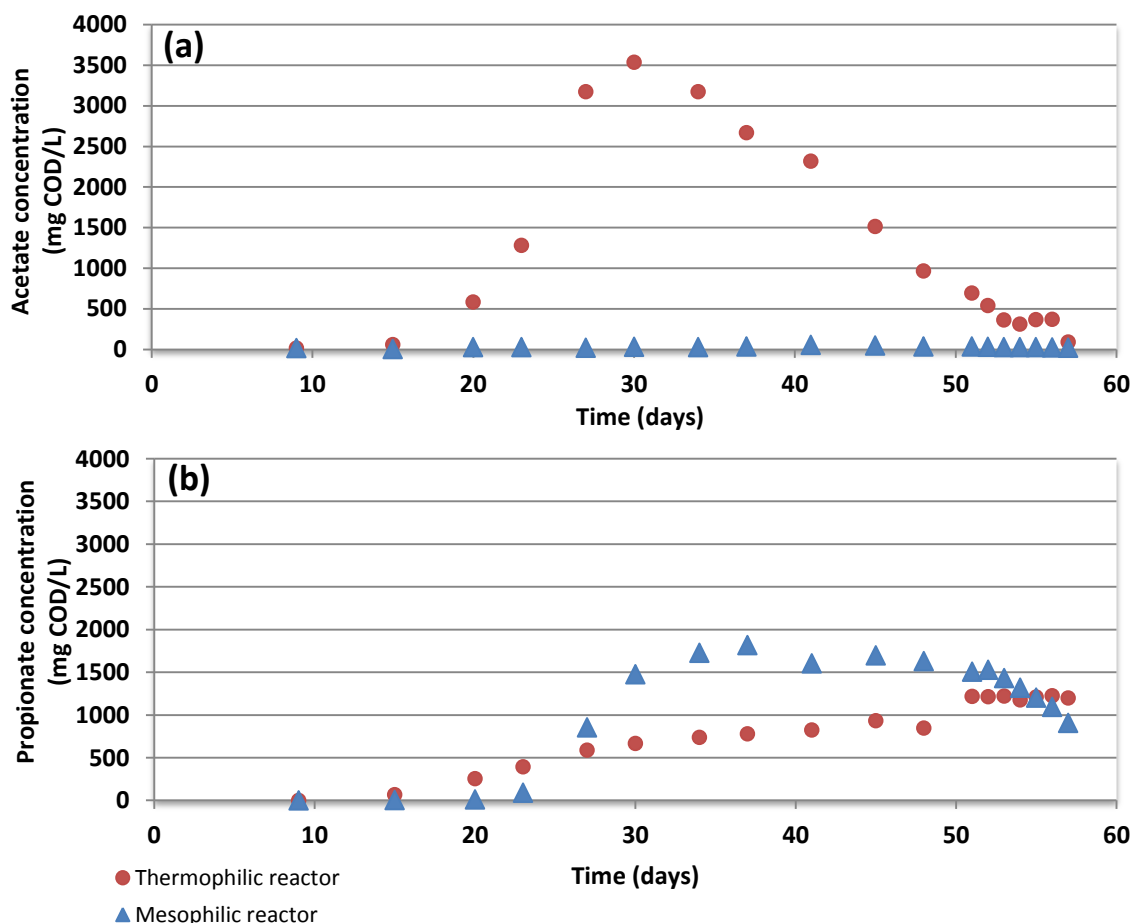

Figure 4-12. Volatile fatty acids concentration during the experiment. The pH level in the thermophilic reactor decreases substantially because of acetate accumulation as shown in Figure 2-a, Appendix IV, accompanied with a drop in the total alkalinity (Figure 5-a, Appendix IV). Also, compare the above figures with Figure a-3, Appendix IV to see the variations in the measured total dissolved COD in the reactors.

The total amount of acetate accumulated from day 15 until day 30 corresponds to the lost methane production. The amount of lost methane can be estimated from the accumulated methane production graph (Figure 4-13). As it is noted on the graph, the accumulated amount of methane should have been around 159 NL at 30th day in case no inhibition occurred- see the linear regression on Figure 3-13 - while only about 125 NL is produced. On the other hand 3533 mg COD/L of acetate accounts for 1.46 moles of methane gas which at STP conditions would be equivalent to about 33 NL. So the amount of accumulated acetate (33NL) added to the current methane produced (125 NL) is, to an acceptable extent, equal to the estimated expected methane production (159 NL) – refer to Appendix II for calculations. This shows that meanwhile methanogens were inhibited by sulfide toxicity, SRB have been able to consume acetate far from any significant disturbance.

Considerable consumption of acetate in the mesophilic reactor reveals that either both or at least one of the acetotrophic groups – methane producing bacteria or sulfate reducing bacteria – are not affected significantly by sulfide toxicity throughout the experiment.

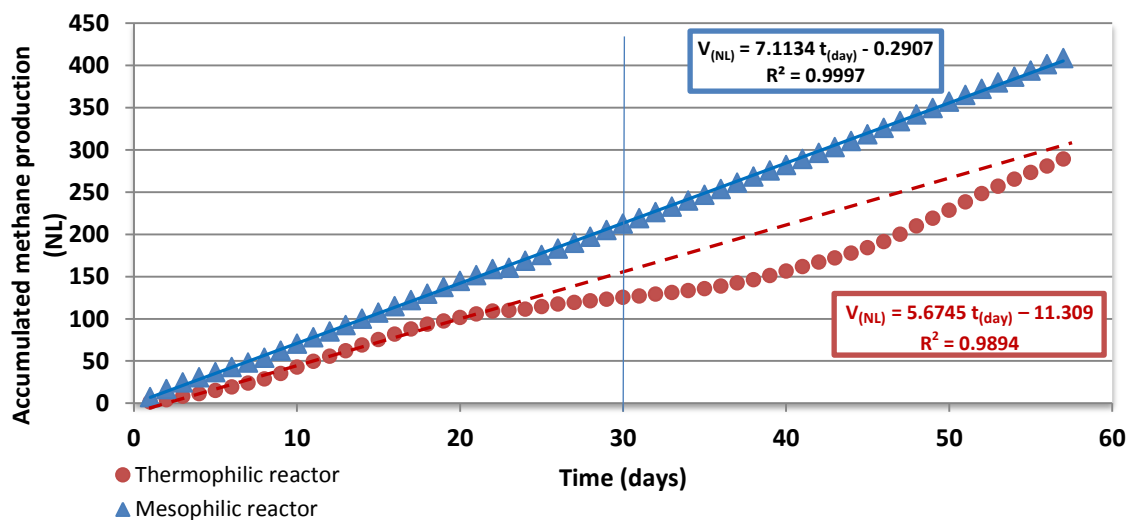

Figure 4-13. Accumulated methane production in thermophilic and mesophilic reactors. As it can be seen major inhibition occurred in the thermophilic reactor around day 20.

Studying the propionate variation during the first 30 days of the experiment (Figure 4-12 (b)) suggests that propionate oxidation is also partly inhibited, perhaps because of high sulfide content (see Figure 4-11). Considering the argument that main propionate degradation pathway is through sulfate reducing reactions (see section 2.3), it can be claimed that accumulation of propionate is probably because of the inhibition of SRB. Since the amount of propionate in the thermophilic reactor is not considerable (700 mg COD/L), it can be mentioned that SRB are not considerably affected by sulfide toxicity. This is in agreement with the discussion from the acetate balance presented previously.

On the other hand, propionate accumulation in the mesophilic reactor is observed on day 27 and tends to increase up to about 1500 mg COD/L in 3 days (day 30). Also, a considerable drop in methane yield of the mesophilic reactor is noticed on day 22. The

drop in methane yield (Figure 4-14) can therefore be linked to lack of acetate meaning that not sulfide toxicity, but insufficient oxidation of propionate causes the starvation of methanogens. In other words, if inhibition of SRB is the reason for accumulation of propionate then a significant decrease in sulfide yield should have occurred as well. Nevertheless, normalizing the amount of hydrogen sulfide against the amount of sulfate fed per day (Figure 4-15) shows that no significant reduction in sulfide yield is happened. This shows that no inhibition of SRB was taken place in the reactor.

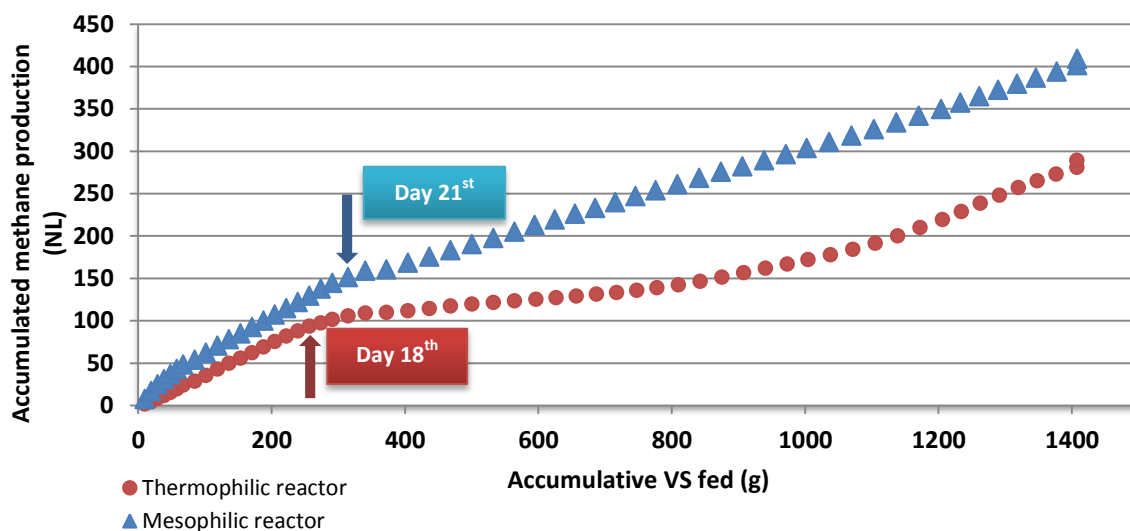

Figure 4-14. Accumulated methane production against accumulative VS fed is illustrated in this figure. This illustration is the best format to indicate different hindrances in methane production process since amount of VS fed directly affects the methane yield. As it can be noticed, major inhibitions occur on 18th and 21st day of the experiment in thermophilic and mesophilic digesters respectively. Attend the declines in the slopes of the trends.

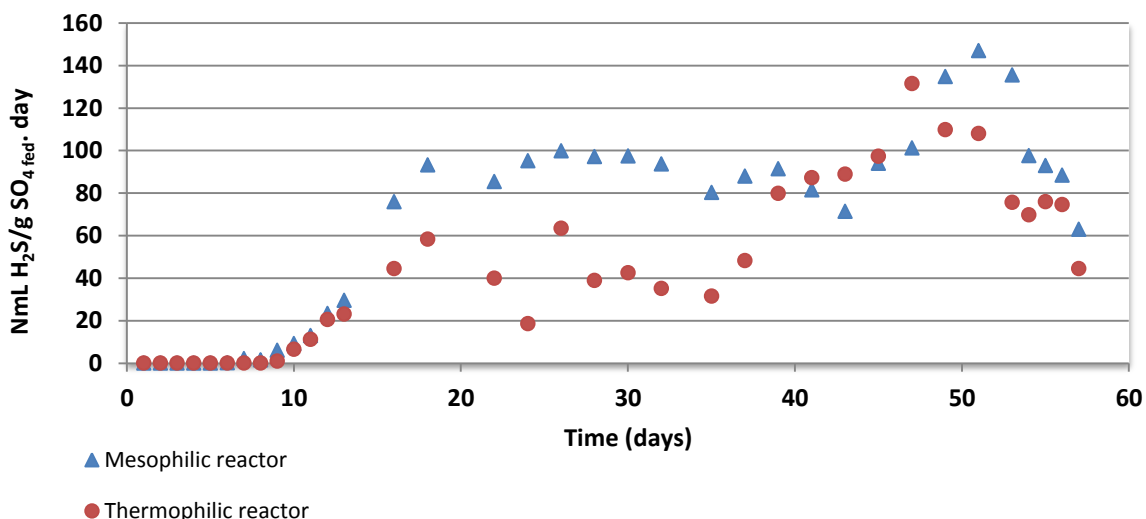

Figure 4-15. Sulfide formation normalized against amount of sulfate fed per day.

Consequently, accepting that lack of acetate -due to incomplete oxidation of propionate- is the cause of methane yield drop, the effect of sulfide toxicity on non-SRB acetogens may be the reason (see Table 2-1). It is also reported that under sulfate rich conditions (small propionate/sulfate ratios) acetate is most favored by SRB (Uberoi and Bhattacharya, 1995). This, somehow, explains high degradation level of acetate in the mesophilic reactor.

It shall be mentioned that the ammonium levels in this study (Figure a-4, Appendix III) were not as high to be able to contribute any inhibitory effect - via corresponding free ammonia - to the methanogenesis process (Haghighatafshar *et al.*, 2012).

4.3.2. Sulfide treatment, a micro-aeration study (day 26 to 52)

Micro-aeration was chosen to be implemented as a sulfide treatment method as described in section 2.6. The method of aeration is described in section 3.3. Implementation of micro-aeration started on day 23. Injection of air into the reactors followed a gradual inclination so that 0.83 liter of air was injected for two days; 1.67 liter for next 3 days; and finally 2 liters from day 28 until 49.

Since precipitation of sulfide via micro-aeration is a biological process its immediate impact on sulfide was not expected. The decrease in sulfide concentration started five days later on day 28 of the experiment.

It should be emphasized that the amount of sulfide dissolved in the reactor depends on the sulfide concentration in the gas phase and not the produced volume. Therefore, the data must be presented as sulfide fraction measured in the gas phase (Figure 4-16).

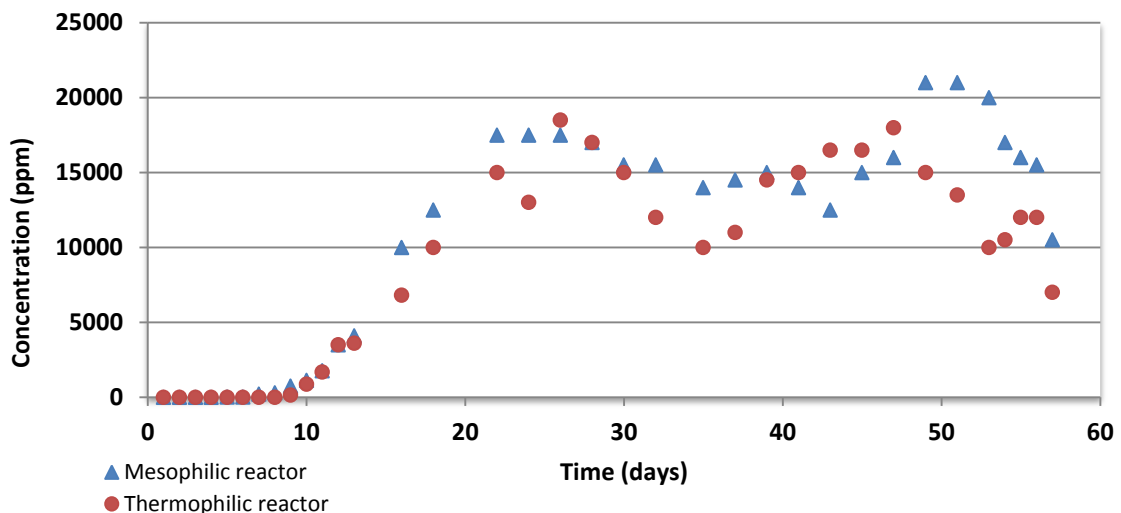

Figure 4-16. Hydrogen sulfide content of produced biogas measured as parts per million (ppm). For concentrations below 2000 ppm portable gas meter was used while for higher concentrations Dräger tubes as described in section 2.1.2 were employed.

As it can be seen from the data presented in Figure 4-16, the thermophilic reactor had a better efficiency in sulfide reduction via aeration. Hydrogen sulfide fraction decreased considerably in about 12 days from about 18000 ppm down to 10000. It should be noted

that the inhibition in thermophilic reactor due to sulfide toxicity occurred at around 10000 ppm.

During the same period (from day 23 to 35), the methane yield was leveled out at about 65 Nml CH₄/gVS_{fed} more or less unaffected (see Figure 4-8). After this period, methane yield tended to increase gradually until day 50, having recovered the yield to about 330 Nml CH₄/gVS_{fed}. Simultaneously hydrogen sulfide production in the thermophilic reactor increased as well.

Unlike the thermophilic reactor, the effect of micro-aeration in the mesophilic reactor is negligible. The decrease observed in hydrogen sulfide content of biogas can be linked to the dilution of gas due to injection of air (about 13%). However the amount of oxygen consumed per day was calculated about 300 NmL/day (approximately 75% of the injected oxygen was consumed while the value for the thermophilic reactor was found to be about 62%). The methane yield for the mesophilic reactor remained unchanged during micro-aeration period (see Figure 4-8).

It was also speculated that micro-aeration enhances the TS and VS reduction. This could be linked to the improved hydrolysis rate under micro-aeration conditions as reported by Tartakovsky *et al.* (2011). The data shows an interesting correlation between TS reduction efficiency and sulfide production (compare Figures 4-10 and 4-16). It seems that it is the developed TS reduction that leads to rises in methane yield and sulfide production. However, further investigations are needed to check whether it is the positive effect of micro-aeration on TS reduction or it is simply adaptation of new substrate with higher TS content.

4.3.3. Short term trials for sulfide reduction

Increased aeration rate

As the final step of aeration, the volume of injected air was raised to 4 liters from day 50 to 52. In this period a considerable drop in hydrogen sulfide production was observed in both reactors while no improvement in methane yield occurred (see Figures 3-8 and 3-9). However due to the short period of the implementation of increased aeration it is not feasible to draw any conclusions. Therefore, prolonged implementation of the study seems to be necessary.

Decreased aeration rate (thermophilic reactor)

The aeration rate in the thermophilic reactor was cut down to 1 liter per day to study its response from day 53 to 55. Higher residual oxygen oxidizes the produced sulfide to sulfate, making it available for SRB to consume it once more. The initial idea was to check if it was the over dosage of air in the reactor that caused an increase in sulfide production.

As a result of the decreased aeration, sulfide production was raised quickly meaning that at the rate of 1 liter air per day, it was still oxygen that limited the sulfide oxidation. It is suggested that aeration with higher rates shall be tried in future.

Addition of FeCl₃ (mesophilic reactor)

Addition of iron chloride to the mesophilic reactor took place in the period of day 53 to 55 with a dose of 7.32 g FeCl₃·6H₂O/day (See Appendix III for calculations). A drastic drop in produced sulfide level (Figure 4-15) was observed on day 54 while the reductions in the following days were not as substantial. Refer to Figure a-7, Appendix IV- for variations in the iron concentration in the reactor. Nevertheless, no positive effect of addition of iron chloride on methane yield was observed. A prolonged study of iron chloride addition on sulfide reduction is needed to investigate its effect on methane yield in a wider time scale.

Shock load of FeCl₃ in both reactors

On the last day of experiment a shock load of iron chloride equal to 24 g FeCl₃·6H₂O/reactor was added to both reactors (see Appendix III for calculations as well as Figures a-6 and a-7, Appendix IV for changes in the iron content of the reactors). The following day hydrogen sulfide concentration was decreased by 5000 ppm in both reactors (H₂S was about 10500 ppm in the mesophilic; and 7000 ppm in the thermophilic reactor) although the dosage was calculated to precipitate the total available sulfide in the reactors. Hydrogen sulfide content of the gas in the headspaces of the reactors was also measured. It was found that the hydrogen sulfide was considerably low in the headspaces i.e. below 1400 ppm. The considerable difference between hydrogen sulfide content of gas collector and headspace can be justified by the following speculations:

- a) It should be noted that the amount of sulfide dissolved in the water of the gas collector was not taken into consideration. It is likely that the amount of precipitated sulfide is compensated by sulfide emissions from dissolved form – in the gas collector – to the gas phase in the collector, leading to higher hydrogen sulfide concentrations than the expected levels.
- b) The reaction rate for sulfate reduction – i.e. sulfide production – is higher than that of iron chloride dissociation and/or S⁰ (FeS⁻) formation. Consequently, due to the overpressure existing in the reactors' headspace the produced sulfide transported into the gas collector would not be able to move backwards in to the reactor to get precipitated. This will cause an unbalanced gas system which may be resolved by gas circulation in the collector-reactor system.

5. Conclusions

Preparation of marine macro algae for continuous anaerobic digestion was found to be problematic so that none of the mechanical methods used in this study – i.e. manual cutting, using kitchen grinder, kitchen mixer, and blender - were applicable in larger scale. Enzymatic pretreatment of algae – using cellulose degrading enzyme – was found to be mainly dependent on the initial physical characteristics of the collected algae, while duration of pretreatment longer than one day did not lead to further significant degradation. The efficiency of enzyme pretreatment of the 2nd batch was about 40% (based on the solids content) due to already partly hydrolyzed conditions of the collected algae.

Comparative batch experiments with enzyme pretreated algae and untreated frozen cut algae, revealed that hydrolysis of untreated algae takes place at minor rates, especially at mesophilic temperatures. Additionally presence of an inhibitory agent in digestion of untreated algae was suggested. The methane potential measured in batch digestion for enzyme pretreated algae was found to be very low in comparison with methane potential of municipal wastewater sludge.

Digestion of enzyme pretreated algae in continuous digestion showed relatively acceptable methane yields (about 400 NmL CH₄/gVS_{fed}) for both thermophilic and mesophilic reactors before inhibition occurred due to high hydrogen sulfide levels. Inhibition of methanogens by sulfide toxicity was only observed at the thermophilic reactor despite the fact that the level of dissolved sulfide was lower according to Henry's law at thermophilic temperatures. Methanogenesis inhibition in the thermophilic reactor – linked to considerable acetate accumulation - was initiated at dissolved sulfide concentration of 22 mg/L (10000 ppm H₂S in gas phase) while the SRB were found to be unaffected. No sulfide toxicity on SRB was observed in the mesophilic and thermophilic reactors. Relatively more resistant methanogens in the mesophilic reactor may have been a result of acclimatization.

Micro-aeration of the thermophilic reactor at the rate of 2 liters of air per day led to improvement of methane yield up to about 330 NmL CH₄/gVS_{fed} although smaller amounts of dissolved oxygen were expected. Oppositely, the mesophilic reactor remained more or less unaffected regarding the methane yield during the micro-aeration period.

Addition of iron chloride considerably decreases the hydrogen sulfide level, especially in the reactors' headspace, but no positive effect on methane yield was observed.

6. Future studies

Application of enzymes in pretreatment of algae is quite an undiscovered field, needing more in-depth investigations. The enzyme used in this study (Cellic® CTec2) was probably not the best choice for pre-hydrolysis of algae. Since the performance of enzymes is mainly driven by the cellular structure of the substrate's cell wall composition hence an in-depth investigation of cellular structure of the algal species included in the study can be of utmost importance. Perhaps a mixture of different enzymes with different proportions could result in better degradation of the algal mass.

Further investigation of micro-aeration method for sulfide oxidation with higher doses of air is suggested. However, since the elemental sulfur and sulfate – as products of micro-aeration – can both be re-consumed by SRB; it is recommended to design and implement a new set-up for aeration of biogas in a separate gas chamber.

It should be indicated that the implementation of sulfide treatment methods tested in this study, all faced severe discrepancies because of practical limitations. Since the amount of produced biogas was measured as the volume of displaced water, considerable concentrations of biogas (specifically hydrogen sulfide) were dissolved in the water of the gas collector. This made it impossible to have a more precise evaluation of sulfide generation. A digester with its headspace as the gas chamber could probably help the evaluation. However, a system able to recirculate the biogas from the collector into the reactor and vice versa could also give better results regarding micro-aeration and iron chloride addition.

As stated before, the HACH LANGE test tubes for sulfate (code LCK 153) were found to be quite uncertain. This is perhaps due to natural color and/or turbidity of the digested sludge liquor; hence adoption of another sulfate measurement method is suggested.

7. References

- Alphenaar, P.A., Visser, A., Lettinga, G., (1993). *The effect of liquid upward velocity and hydraulic retention time on granulation in UASB reactors treating wastewater with a high sulphate content. Bioresour. Technol.* 43, 249-258.
- Amanieu, M., Baleux, B., Gue'lorget, O., Michel, P., (1975). *Etude biologique et hydrologique d'une crise dystrophique (malai'gue) dans l'e'tang du Pre'vost, He'rault. Vie et Milieu.* 25B, 175-204.
- Baltic Nest Institute at University of Stockholm, Salinity converter spreadsheet downloaded at http://nest.su.se/mnode/methods/spreadsheets/cond_to_sal_converter.xls
- Benjamin, M.M., Woods, S.L., Ferguson, J.F., (1984). *Anaerobic toxicity and biodegradability of pulp mill waste constituents. Water Res.* 18, 601-607.
- Bock, A. K., Priegerkraft, A. & Schonheit, P. (1994). *Pyruvate - a novel substrate for growth and methane formation in methanosarcina-barkeri. Archives of microbiology,* 161, 33-46.
- Briand, X., Morand, P., (1997). *Anaerobic digestion of Ulva sp. 1: relationship between Ulva composition and methanisation. Journal of Applied Phycology* 9 (6), 511-524.
- Bruhn, A., Dahl, J., Nielsen, H.B., Nikolaisen, L., Rasmussen, M.B., Markager, S., Olesen, B., Arias, C., Jensen, P.D., (2011). *Bioenergy potential of Ulva lactuca: biomass yield, methane production and combustion. Bioresource Technology* 102, 2595-2604.
- Buswell, E.G. and Neave, S.L., (1930). *Laboratory studies of sludge digestion. Illinois Division of State Water Survey, Bulletin no. 30.*
- Castel, J., Caumette, P., Herbert, R.A., (1996). *Eutrophication gradients in coastal lagoons as exemplified by the Bassin d'Arcachon and the Etang du Pre'vost. Hydrobiologia* 329, ix - xxviii.
- Cecchi, F., Pavan, P., Mata-Alvarez, J., (1996). *Anaerobic co-digestion of sewage sludge: application to the macroalgae from the Venice lagoon. Resour. Conserv.Recycl.* 17, 57-66.
- Charlier RH, Morand P, Finkl CW, Thys A (2007) *Green tides on the Brittany Coasts. Environmental Research, Engineering and Management* 3(41):52-59
- Chen, y., Cheng, J. J., Creamer, K. S. (2008). *Inhibition of anaerobic digestion process: a review. In: Biores. Technol.* 99, 4044-4064.
- Choi, E. and Rim, J. M. (1991). *Competition and inhibition of sulfate reducers and methane producers in anaerobic treatment. Wat. Sci. Tech.* 23, 1259-1264.
- Chynoweth, D. P. and Srivastava, V. J.,(1980). *Methane production from marine biomass. Paper presented at International Symposium on Biogas, Microalgae and Livestock Wastes, Taipei. Taiwan. Institute of GasTechnology. IL. 15-17.*
- Colleran, E., Pender, S., (2002). *Mesophilic and thermophilic anaerobic digestion of sulphate-containing wastewaters. Water Sci. Technol.* 45 (10), 231-235.

Colleran, E., Pender, S., Phipott, U., O'Flaherty, V., Leahy, B., (1998). Full-scale and laboratory-scale anaerobic treatment of citric acid production wastewater. *Biodegradation* 9, 233–245.

Colleran, E., Finnegan, S. & Lens, P. (1995). Anaerobic treatment of sulfate-containing waste streams. *Antonie van Leeuwenhoek International Journal of General and Molecular Microbiology*, 67, 29-46.

Colleran, E., Finnegan, S., O'Keefe, R.B., (1994). Anaerobic digestion of high sulphate containing wastewater from the industrial production of citric acid. *Water Sci. Technol.* 30 (12), 263–273.

Davidsson, Åsa, (2007). Increase of Biogas Production at Wastewater Treatment Plants Addition of urban organic waste and pre-treatment of sludge, Ph.D. Thesis, Dept. of Water and Environmental Engineering, Lund University.

Dean, J. A. (1992). *Lange's Handbook of Chemistry*. McGraw-Hill, Inc.

De Bruyn, W. J., E. Swartz, J. H. Hu, J. A. Shorter, P. Davidovits, D. R. Worsnop, M. S. Zahniser, and C. E. Kolb, (1995). Henry's law solubilities and Setchenow coefficients for biogenic reduced sulfur species obtained from gas-liquid uptake measurements. *J. Geophys. Res.*, 100D, 7245–7251.

De Smul, A., Goethals, L., Verstraete, W., (1999). Effect of COD to sulphate ratio and temperature in expanded-granular-sludge-blanket reactors for sulphate reduction. *Process Biochem.* 34, 407-416.

Edwards, T. J., G. Maurer, J. Newman, and J. M. Prausnitz, (1978). Vapor-liquid equilibria in multicomponent aqueous solutions of volatile weak electrolytes. *AIChE J.*, 24, 966–976.

Gayh U., Gtooss A., Behrendt J., (2010). Desulphurisation of biogas analysis, evaluation and optimisation. Paper presented at the Third international symposium on energy from biomass and waste, Venice, Italy, 8–10 November.

Gerardi, M.H., (2003). *The Microbiology of Anaerobic Digestion. Introduction to Operational Conditions*, John Wiley & Sons, Inc. ISBN 0-471-20693-8.

Ghosh, S., Klass, D. L. and Chynoweth, D. P., (1981). Bioconversion of *Macrocystis pyrifera* to methane. *J. Chem. Tech. Biotechnol.*, 31, 791-807.

Gujer, W. & Zehnder, A. J. B., (1983). Conversion processes in anaerobic digestion. *Water Science and Technol.* 15, 127-167.

Gupta, A., Flora, J.R.V., Gupta, M., Sayles, G.D., Suidan, M.T., (1994). Methanogenesis and sulphate reduction in chemostats-1: kinetic studies and experiments. *Water Res.* 28, 781-793.

Habig, C., De Busk, T. A. and Ryther, J. H., (1984). The effect of nitrogen content on methane production by the marine algae *Gracilaria tikvahiae* and *Ulva* sp. *Biomass*, 4, 239-251.

Haghighatafshar, A., Kjerstadius, H., Ossiansson, E., la Cour Jansen, J., Davidsson, Å., (2012). Calibration of a mathematical model for anaerobic digestion with special emphasis on estimation hydrolysis rate constants. Presented as a poster at Nordic Biogas Conference 2012 – Copenhagen.

Accessible at <http://www.sgc.se/nbc2012/Resources/posters/Salar%20Haghighatafshar%20-%20NBC2012.pdf> or contact Water and Environmental Engineering at Chemical Engineering Department of Lund University for the full report as project course VVA920 (January 2012).

Hanisak, M. D., (1981). Methane production from the red seaweed *Gracilaria tikvahiae*. In *Proc. 10th Int. Seaweed Symp.*, ed. T. Levring. Walter de Gruyter, Berlin, pp. 681-686.

Hansen, T.A., (1993). Carbon metabolism of sulfate-reducing bacteria. In: Odom, J.M., Rivers- Singleton, J.R. (Eds.), *The Sulfate-reducing Bacteria: Contemporary Perspectives*. Springer-Verlag, NY, pp. 21-40.

Hansen, T.L., Schmidt, J.E., Angelidaki, I., Marca, E., Jansen, J.la C., Mosbæk, H., Christensen, T.H., (2004). Method for determination of methane potentials of solid organic waste. *Waste Management* 24, 393-400.

Hanssen, J. F., Indergaard, M., Ostgaard, K., Baevre, O. A., Pedersen, T. A. and Jensen, A., (1987). Anaerobic digestion of *Laminaria* spp. and *Ascophyllum nodosum* and application of end products. *Biomass*, 14, 1-13.

Hansson, G., (1981). *Methane Fermentations: End Product Inhibition Thermophilic Methane Formation and Production of Methane from Algae*. Ph.D. Dissertation, Dept. of Technical Microbiology, University of Lund, Sweden.

Harada, H., Uemura, S., and Momonoi, K., (1994). Interactions between sulphate-reducing bacteria and methane-producing bacteria in UASB reactors fed with low strength wastes containing different levels of sulfate. *Wat. Res.* 28, 355-367.

Hepner, B., Zellner, G., Diekman, H., (1992). Start-up and operation of a propionate-degrading fluidized-bed reactor. *Appl. Microbiol. Biotechnol.* 36, 810-816.

Hershey, J.P., Plese, T., Millero, F.J., (1988). The pK_1^* for the dissociation of H_2S in various ionic media. *Geochimica et Cosmochimica Acta* 52:8, 2047-2051.

Hilton, B.L., Oleszkiewicz, J.A., (1990). Sulfide-induced inhibition of anaerobic digestion-closure. *J. Environ. Eng.* 116, 1007-1008.

Hoeks, F. W. J. M. M., Ten Hoopen, H. J. G., Roels, J. A., and Kuenen, J. G. (1984). Anaerobic treatment of acid water (methane production in a sulfate-rich environment). *Progr. Ind. Microbiol.* 20, 113-119.

Isa, Z., Grusenmeyer, S., and Verstraete, W. (1986a). Sulfate reduction relative to methane production in high-rate anaerobic digestion: technical aspects. *Appl. Environ. Microbiol.* 51, 572-579.

Isa, Z., Grusenmeyer, S., and Verstraete, W. (1986b). Sulfate reduction relative to methane production in high-rate anaerobic digestion: Microbiological aspects. *Appl. Environ. Microbiol.* 51, 580-587.

Jagadabhi, P.S., Kaparaju, P., Rintala, J., (2010). Effect of micro-aeration and leachate replacement on COD solubilization and VFA production during mono-digestion of grass-silage in one-stage leach-bed reactors. *Bioresour. Technol.* 101, 2818-2824.

- Janssen, A. J. H., Ma, S. C., Lens, P. and Lettinga, G. (1997), *Performance of a sulfide-oxidizing expanded-bed reactor supplied with dissolved oxygen*. *Biotechnol. Bioeng.*, 53: 32–40.
- Janssen, A. J. H., Sleyster, R., van der Kaa, C., Jochemsen, A., Bontsema, J. and Lettinga, G. (1995), *Biological sulphide oxidation in a fed-batch reactor*. *Biotechnol. Bioeng.*, 47: 327–333.
- Jenicek, P., Keclik, F., Maca, J., Bindzar, J., (2008). *Use of microaerobic conditions for the improvement of anaerobic digestion of solid wastes*. *Water Sci. Technol.* 58 (7), 1491–1496.
- Jenicek, P., Koubova, J., Bindzar, J., Zabranska, J., (2010). *Advantages of anaerobic digestion of sludge in microaerobic conditions*. *Water Sci. Technol.* 62 (2), 427–434.
- Kassam, Z. A., Yerushalmi, L. , Guiot, S. R., (2003). *A Market Study on the Anaerobic Wastewater Treatment Systems*. *Water, Air, and Soil Pollution*, 143, 179-192.
- Khanal, S.K., (2008), *Anaerobic biotechnology for bioenergy production – Principles and applications*. Wiley-Blackwell publications, ISBN 978-0-8138-23461.
- Klemps, R., Cypionka, H., Widdel, F., Pfennig, N., (1985). *Growth with hydrogen, and further physiological characteristics of Desulfotomaculum species*. *Arch. Microbiol.* 143, 203–208.
- Koster, I. W., Rinzema, A., de Vegt, A. L., and Lettinga, G. (1986). *Sulfide inhibition of the methanogenic activity of granular sludge at different pH levels*. *Wat. Res.* 12, 1561–1567.
- Laanbroek, H. J., Geerlings, H. J., Sijtsma, L., and Veldkamp, H. (1984). *Competition for sulfate and ethanol among Desulfobacter, Desulfobulbus, and Desulfovibrio species isolated from intertidal sediments*. *Appl. Environ. Microbiol.* 47, 329–334.
- Leitão, R. C., Van Haandel, A. C., Zeeman, G. & Lettinga, G. (2006). *The effects of operational and environmental variations on anaerobic wastewater treatment systems: A review*. *Bioresource Technology*, 97, 1105-1118.
- Lens, P. N. L., Visser, A., Janssen, A. J. H., POL, L. W. H. & Lettinga, G. (1998). *Biotechnological treatment of sulfate-rich wastewaters*. *Critical Reviews In Environmental Science And Technology*, 28, 41-88.
- Lide, D. R. (1993). *CRC Handbook of Chemistry and Physics, 73rd ed.*, CRC Press, Boca Raton, FL. Lo, K. V. and Liao, P. H. (1990). *Anaerobic treatment of baker's yeast wastewater. I. Start-up and sodium molybdate addition*. *Biomass* 21, 207–218.
- Lide, D. R. and H. P. R. Frederikse, (1995). *CRC Handbook of Chemistry and Physics, 76th Edition*. CRC Press, Inc., Boca Raton, FL.
- Lovley, D. R. (1985). *Minimum threshold for hydrogen metabolism in methanogenic bacteria*. *Appl. Environ. Microbiol.* 49, 1530–1531.
- Maillacheruvu, K.Y., Parkin, G.F., Peng, W.C., Kuo, W.C., Oonge, Z.I., Lebduschka, V., (1993). *Sulfide toxicity in anaerobic systems fed sulfate and various organics*. *Water Environ. Res.* 65, 100-109.

Martone, P. T., Estevez, J. M., Lu, F., Ruel, K., Denny, M. W., Somerville, C. & Ralph, J. (2009). Discovery of lignin in seaweed reveals convergent evolution of cell-wall architecture. *Current biology* : CB, 19, 169-175.

McCartney, D.M., Oleszkiewicz, J.A., (1991). Sulfide inhibition of anaerobic degradation of lactate and acetate. *Water Res.* 25 (2), 203 -209.

McCartney, D.M., Oleszkiewicz, J.A., (1993). Competition between methanogens and sulphate reducers: effect of COD: sulphate ratio and acclimatization. *Water Environ. Res.* 65, 655 -664.

Mizuno O., Li Y. Y. and Noike T., (1994). Effects of sulfate concentration and sludge retention time on the interaction between methane production and sulfate reduction for butyrate. *Wat. Sci. Tech.* 30(8), 45-54.

Morand, P., Briand, X., Charlier, R.H., (2006). Anaerobic digestion of *Ulva* sp. 3 liquefaction juices extraction by pressing and a technico-economic budget. *Journal of Applied Phycology* 18 (6), 741–755.

Morand, P., Briand, X., (1999). Anaerobic digestion of *Ulva* sp. 2. Study of *Ulva* degradation and methanisation of liquefaction juices. *Journal of Applied Phycology* 11: 165–177.

Mulder, A., (1984). The effects of high sulphate concentrations on the methane fermentation of wastewater. In: Houwink, E.H., Van der Meer, R.R. (Eds.), *Innovations in Biotechnology*. Elsevier Science, Amsterdam, pp. 133–143.

Nedergaard R.I., Risgaard-Petersen N., Finster K. (2002) The importance of sulfate reduction associated with *Ulva lactuca* thalli during decomposition: a mesocosm experiment. *Journal of Experimental Marine Biology and Ecology* 275: 15– 29.

Nielsen, P. H. (1987). Biofilm dynamics and kinetics during high rate sulfate reduction under anaerobic conditions. *Appl. Environ. Microbiol.* 53, 27–32.

Nkemka V. N., Murto M., (2010). Evaluation of biogas production from seaweed in batch tests and in UASB reactors combined with the removal of heavy metals. *Journal of Environmental Management* 91, 1573-1579.

Novozyme, (2010), *Novozymes Cellic® CTec2 and HTec2 - Enzymes for hydrolysis of lignocellulosic – Application sheet*.

Noyola, A., Morgan-Sagastume, J. M. & López-Hernández, J. E. (2006). Treatment of Biogas Produced in Anaerobic Reactors for Domestic Wastewater: Odor Control and Energy/Resource Recovery. *Reviews in Environmental Science and Bio/Technology*, 5, 93-114.

O'Flaherty, V., Mahony, T., O'Kennedy, R., Colleran, E., (1998a). Effect of pH on growth kinetics and sulphide toxicity thresholds of a range of methanogenic, syntrophic and sulphate-reducing bacteria. *Process Biochem.* 33 (5), 555–569.

O'Flaherty, V., Lens, P., Leaky, B., Colleran, E., (1998b). Long term competition between sulphate reducing and methane-producing bacteria during full-scale anaerobic treatment of citric acid production wastewater. *Water Res.* 32 (3), 815–825.

O'Flaherty, V., Lens, P., deBeer, D., Colleran, E., (1997). *Effect of feed composition and upflow velocity aggregate characteristics in anaerobic upflow reactors. Appl. Microbiol. Biotechnol.* 47, 102–107.

Okabe S., Nielsen P. H., and Characklis W. G. (1992). *Factors affecting microbial sulfate reduction by Desulfovibrio desulfuricans in continuous culture: limiting nutrients and sulfide concentrations. Biotech. Bioeng.* 40, 725–734.

Oleszkiewicz, J.A., Marsteller, T., McCartney, D.M., (1989). *Effects of pH on sulfide toxicity to anaerobic processes. Environ. Technol. Lett.* 10, 815–822.

Omil, F., Lens, P., Hulshoff Pol, L.W., Lettinga, G., (1996a). *Effect of upward velocity and sulphide concentration on volatile fatty acid degradation in a sulphidogenic granular sludge reactor. Process Biochem.* 31, 699–710.

Omil, F., Mende'z, R., Lema, J.M., (1996b). *Anaerobic treatment of seafood processing waste waters in an industrial anaerobic pilot plant. Water SA* 22 (2), 173–182.

Omil, F., Mende'z, R., Lema, J.M., (1995). *Anaerobic treatment of saline wastewaters under high sulphide and ammonia content. Bioresour. Technol.* 54, 269–278.

Oude Elferink, S. J. W. H., Visser, A., Hulshoff Pol, L. W., and Stams, A. J. M. (1994). *Sulfate reduction in methanogenic bioreactors. FEMS Microbiol. Rev.* 15, 119–136.

Parkin, G.F., Lynch, N.A., Kuo, W., Van Keuren, E.L., Bhattacharya, S.K., (1990). *Interaction between sulfate reducers and methanogens fed acetate and propionate. Res. J. Water Pollut. Control Fed.* 62, 780–788.

Parkin, G.F., Speece, R.E., Yang, C.H.J., Kocher, W.M., (1983). *Response of methane fermentation systems to industrial toxicants. J. Water Pollut. Control Fed.* 55, 44–53.

Peu P., Sassi, J. F., Girault R., Picard S., Patricia Saint-Cast, Béline F., Dabert P., (2011). *Sulphur fate and anaerobic biodegradation potential during co-digestion of seaweed biomass (Ulva sp.) with pig slurry. Bioresour. Technol.* 102, 10794–10802.

Pichon M., Rouger J. and Junet E. (1988). *Anaerobic treatment of sulphur-containing effluents. Wat. Sci. Technol.* 20, 133–141.

Polprasert, C. and Haas, C. N. (1995). *Effect of sulfate on anaerobic processes fed with dual substrates. Wat. Sci. Tech.* 31, 101–107.

Postgate, J. R. (1984). *The Sulphate Reducing Bacteria.* 2nd ed. Cambridge University Press, Cambridge, UK.

Qatibi, A. I., Bories, A., and Garcia, J. L. (1990). *Effects of sulfate on lactate and C2-, C3-volatile fatty acid anaerobic degradation by a mixed microbial culture. Antonie van Leeuwenhoek* 58, 241–248.

Rigoni-Stern, S., Rismondo, R., Szpyrkowicz, L., Zilio-Grandi, F. and Vigato, P. A., (1990). *Anaerobic digestion of nitrophilic algae biomass from the Venice lagoon. Biomass*, 23, 179–199.

- Rintala, J. A. & Puhakka, J. A., (1994). *Anaerobic treatment in pulp- and paper-mill waste management: A review. Bioresource Technology*, 47, 1-18.
- Rinzema, A. and Lettinga, G., (1988a). *Anaerobic treatment of sulfate-containing waste water. In: Biotreatment Systems, Vol. III, pp. 65–109. (Wise, D. L., Ed.) CRC Press, Boca Raton, FL.*
- Rinzema, A. and Lettinga, G., (1988b). *The effect of sulfide on the anaerobic degradation of propionate. Environ. Technol. Lett.* 9, 83–88.
- Rinzema, A., Paardekooper, A. H., De Vegt, A. L., and Lettinga, G., (1986). *Anaerobic treatment of edible oil refinery waste water in granular sludge UASB reactors. In: Proc. EWPCA Conf. Anaerobic Treatment, A Grown Up Technology, pp. 205–217. Amsterdam, The Netherlands.*
- Rolf Sander, (1999). *Compilation of Henry's Law Constants for Inorganic and Organic Species of Potential Importance in Environmental Chemistry. Compiled at Max-Planck Institute of Chemistry* Accessible: <http://www.ceset.unicamp.br/~mariaacm/ST405/Lei%2520de%2520Henry.pdf>
- Schlegel, H. G., (1981). *Allgemeine Mikrobiologie. V. Auflage, Thieme Verlag, Stuttgart, Germany.*
- Shin, H. S., Oh, S. E., and Bae, B. U., (1996). *Competition between SRB and MPB according to temperature change in the anaerobic treatment of tannery wastes containing high sulfate. Environ. Technol.* 17, 361–370.
- Sierra-Alvarez, R. and Lettinga, G., (1991). *The methanogenic toxicity of wastewater lignins and lignin related compounds. J. Chem. Technol. Biotechnol.*, 50: 443–455.
- SIS, Swedish Institute for Standards (2000). *Characterization of sludge – determination of dry residue and water content (SS-EN 12880) and determination of loss on ignition of dry mass (SS-EN 12879).*
- Soto, M., Mende'z, R., Lema, J.M., (1991). *Biodegradability and toxicity in the anaerobic treatment of fish canning wastewaters. Environ. Technol.* 12, 669–677.
- Soto, M., Mende'z, R., Lema, J.M., (1992). *Characterization and comparison of biomass from mesophilic and thermophilic fixed bed anaerobic digesters. Water Sci. Technol.* 25, 203–212.
- Strocchi, A., Furne, J., Ellis, C. & Levitt, M. D., (1994). *Methanogens outcompete sulphate reducing bacteria for H₂ in the human colon. Gut*, 35, 1098.
- Strocchi, A., Furne, J. K., Ellis, C. J. & Levitt, M. D., (1991). *Competition for hydrogen by human faecal bacteria: evidence for the predominance of methane producing bacteria. Gut*, 32, 1498-1501.
- Stucki, G., Hanselman, K.W., Hu' rzeler, A., (1993). *Biological sulphuric acid transformation: reactor design and process optimization. Biotechnol. Bioeng.* 41, 303–315.
- Tartakovsky, B., Mehta, P., Bourque, J. & Guiot, S.R., (2011). *Electrolysis-enhanced anaerobic digestion of wastewater. Bioresource technology*, 102, no. 10, pp. 5685-5691.
- Thauer, R.K., Jungermann, K. and Decker, K., (1977) *Energy conservation in chemotrophic anaerobic bacteria. Bacteriol. Rev.* 41, p. 100-180.

- Thiele, J. H., and Zeikus, J. G., (1988), *Control of Interspecies Electron Flow during Anaerobic Digestion: Significance of Formate Transfer versus Hydrogen Transfer during Syntrophic Methanogenesis in Flocs*, *Applied and environmental Microbiology*. 54: pp. 20-29.
- Troiano, R. A., Wise, D. L., Augenstein, D. C., Kispert, R. G. and Cooney, C. L.,(1976). *Fuel gas production by anaerobic digestion of kelp*. *Resource Recovery and Conservation*, 2, 171-176.
- Tursman, J.F., Cork, D.J., (1988). *Influence of sulfate and sulfate-reducing bacteria on anaerobic digestion technology*. In: Mizradi, A., van Wezel, A. (Eds.), *Biological Waste Treatment*. Alan R. Liss, Inc.
- Uberoi, V. and Bhattacharya, S. K., (1995). *Interactions among sulfate reducers, acetogens, and methanogens in anaerobic propionate systems*. *Wat. Environ. Res.* 67, 330–339.
- Ueki, K., Ueki, A., and Simogoh, Y., (1988). *Terminal steps in the anaerobic digestion of municipal sewage sludge: effects of inhibitors of methanogenesis and sulfate reduction*. *J. Gen. Appl. Microbiol.* 34, 425–432.
- Ueki, K., Ueki, A., Takahashi, K., and Iwatsu, I., (1992). *The role of sulfate reduction in methanogenic digestion of municipal sewage sludge*. *J. Gen. Appl. Microbiol.* 38, 195–207.
- Vavilin, V. A., Vasiliev, V. B., Rytov, S. V. & Ponomarev, A. V., (1994). *Self-oscillating coexistence of methanogens and sulfate-reducers under hydrogen sulfide inhibition and the pH-regulating effect*. *Bioresource Technology*, 49, 105-119.
- Viaroli, P., Bartoli, M., Bondavalli, C., Naldi, M., (1995). *Oxygen fluxes and dystrophy in a coastal lagoon colonized by *Ulva rigida* (Sacca di Goro, Po River Delta, Northern Italy)*. *Fresenius Environ. Bull.* 4,381–386.
- Viaroli, P., Naldi, M., Bondavalli, C., Bencivelli, S., (1996). *Growth of the seaweed *Ulva rigida* C. Agardh in relation to biomass densities, internal nutrient pools and external nutrient supply in the Sacca di Goro (Northern Italy)*. *Hydrobiologia* 329, 93– 103.
- Visser, A., Gao, Y., and Lettinga, G., (1992). *The anaerobic treatment of a synthetic sulfate containing wastewater under thermophilic (55°C). conditions*. *Wat. Sci. Tech.* 25, 193–202.
- Visser, A., Nozhevnikova, A. N., and Lettinga, G., (1993a). *Sulfide inhibition of methanogenic activity at various pH levels at 55°C*. *J. Chem. Technol. Biotechnol.* 57, 9–13.
- Visser, A., Gao, Y., and Lettinga, G., (1993b). *Effects of short-term temperature increases on the mesophilic anaerobic breakdown of sulfate containing synthetic wastewater*. *Wat. Res.* 27, 541–550.
- Visser, A., Beeksmā, I., van der Zee, F., Stams, A. J. M., and Lettinga G., (1993c). *Anaerobic degradation of volatile fatty acids at different sulfate concentrations*. *Appl. Microbiol. Biotechnol.* 40, 549–556.
- Visser, A., Alphenaar, P. A., Gao, Y., and Lettinga, G., (1993d). *Granulation and immobilisation of methanogenic and sulfate-reducing bacteria in high rate anaerobic reactors*. *Appl. Microbiol. Biotechnol.* 40, 575–581.

Visser, A., Hulshoff Pol, L. W., and Lettinga, G., (1996). *Competition of methanogenic and sulfidogenic bacteria*. *Wat. Sci. Tech.* 33, 99–110.

Vogels, G. D., Keltjens, J., and van der Drift, C., (1988). *Biochemistry of methane production*. In: *Biology of Anaerobic Microorganisms*, pp. 707–770. (Zehnder, A. J. B., Ed.) John Wiley & Sons, New York.

Wei, D. W. and Osseo-Asare, K. (1996). *Particulate pyrite formation by the Fe³⁺/HS⁻ reaction in aqueous solutions: Effects of solution composition*. *Colloids and Surfaces a Physicochemical and Engineering Aspects* 118, 51-61.

Whitman, W. B. , Bowen, T. L. and Boone, D. R., (2006). “The methanogenic bacteria”, in *Prokaryotes*, vol. 3; *A handbook on the biology of bacteria*, D. M., S. Falkow, E. Rosenberg, K-H. Schleifer, and E. Stackebrandt, Eds. 3rd ed., pp. 165-207.

Widdel, F. and Hansen, T.A., (1992). *The dissimilatory sulfate- and sulfur-reducing bacteria*. *The Prokaryotes*, 2nd ed, pp. 583-624. (Balows, A., Trüper, H.G., Dworkin, M., Harder, W., and Schleifer, K.-H., Eds.) Springer-Verlag, New York

Widdel, F., (1988). *Microbiology and ecology of sulfate- and sulfur-reducing bacteria*. In: *Biology of Anaerobic Microorganisms*, pp. 469–586. (Zehnder, A. J. B., Ed.) John Wiley & Sons, New York.

Wilhelm, E., Battino, R., and Wilcock, R. J., (1977). *Low-pressure solubility of gases in liquid water*. *Chem. Rev.* 77, 219–262.

Yoda, M., Kitagawa, M., and Miyayi, Y., (1987). *Long term competition between sulfate-reducing and methane-producing bacteria in anaerobic biofilm*. *Wat. Res.* 21, 1547–1556.

Yuan, X., Shi, X., Zhang, D., Qiu, Y., Guo, R., Wang, L., (2011). *Biogas production and microcystin biodegradation in anaerobic digestion of blue algae*. *Energy & Environmental Science*, 4, 1511-1515.

Zamalloa C., Vrieze J.D., Boon N., Verstraete W., (2012). *Anaerobic digestibility of marine microalgae *Phaeodactylum tricorutum* in a lab-scale anaerobic membrane bioreactor*. *Appl Microbiol Biotechnol* 93:859–869

Appendix I

Pretreated algae from reactor 30Enz5 were fed into mesophilic batch bottles while the output of 45Enz5 was used for thermophilic batch experiment. In order to be able to calculate the net methane potential of enzyme pretreated algae, it is necessary to have an estimation of the enzyme's methane potential. For this reason Buswell formula (Buswell and Neave, 1930) – simplified for exclusion of nitrogen (Davidsson, 2007) – was employed as below:

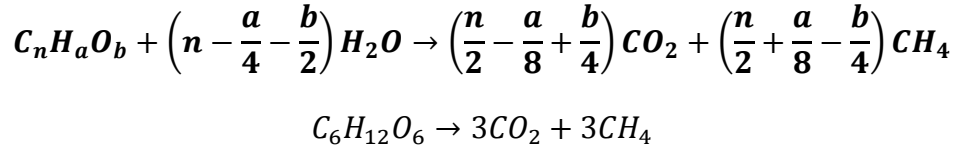

For calculation of total glucose in each reactor we can use the following equation:

Total glucose in reactor

$$= \text{Concentration of glucose in enzyme} \\ \times \frac{\text{added amount of enzyme}}{\text{density of enzyme}}$$

For 274 g/L glucose in the enzyme (refer to 2.2.2) and enzyme's density equal to 1158 g/L (measured in lab) we have:

$$\text{Total glucose in reactor 30Enz5: } 274 \frac{g}{L} \times \frac{23.59 \frac{g_{added}}{L}}{1158 \frac{g}{L}} = 5.582 \text{ g glucose}$$

$$\text{Total glucose in reactor 45Enz5: } 274 \frac{g}{L} \times \frac{35.38 \frac{g_{added}}{L}}{1158 \frac{g}{L}} = 8.371 \text{ g glucose}$$

Assuming that all the added enzyme is later passed through the sieve, the concentration of sugar in the substrate is:

$$\text{Glucose in sieved - pretreated algae (30Enz5): } \frac{5.582 \text{ g}}{714.6 \text{ g}} = 0.00781 \frac{g_{glucose}}{g}$$

$$\text{Glucose in sieved - pretreated algae (45Enz5): } \frac{8.371 \text{ g}}{739.8 \text{ g}} = 0.01132 \frac{g_{glucose}}{g}$$

Average amount of glucose in the batches has been:

$$\text{Mesophilic experiment : } 0.00781 \frac{g_{glucose}}{g} \times 200.25 \text{ g} = 1.564 \text{ g}_{glucose} (8.681 \times 10^{-3} \text{ mole})$$

$$\text{Thermophilic experiment : } 0.01132 \frac{g_{glucose}}{g} \times 133.40 \text{ g} = 1.510 \text{ g}_{glucose} (8.381 \times 10^{-3} \text{ mole})$$

The above amounts of glucose would then be converted into methane according to the Buswell formula as:

Mesophilic: $3 \times 8.681 \times 10^{-3}$ moles of methane \cong **0.584 Normal liters**

Thermophilic: $3 \times 8.381 \times 10^{-3}$ moles of methane \cong **0.564 Normal liters**

Appendix II

Maximum amount of acetate accumulation in the thermophilic reactor accounts for 3533 mg COD/L which is equivalent to 4302.3 mg/L of acetate as presented below:

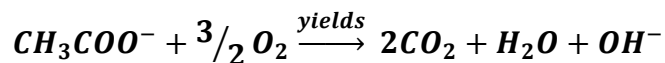

1 mole of acetate is oxidized by 1.5 moles of oxygen. So 3533 mg COD/L which is equal to 110.41 mmol O₂/L oxidizes 73.61 mmol/L acetate.

Since the effective volume of the reactor is 20 liters (Table 2-1) total amount of accumulated acetate will be:

$$73.61 \text{ mmol/L} \times 20 \text{ L} = 1472.2 \text{ mmol}$$

Equivalent methane yield can be calculated based on the stoichiometry of acetate conversion to methane:

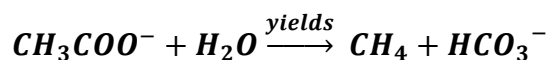

Assuming complete conversion of acetate to methane, 1472.2 mmol of methane is expected to be formed which under STP conditions a volume of about 33 NL as presented below:

Molar volume of gases at STP (1 atm, 0 °C) = 22.414 liters/mol

$$1472.2 \text{ mmol} = 1.4722 \text{ moles} \rightarrow 1.4722 \times 22.414 \cong 33 \text{ NL}$$

3533 mg COD/L as acetate yields 33 liters of methane under STP conditions.

Appendix III

Calculation of aeration dosage

Amount of sulfate fed at the time was about 1310 mg/L. Considering that 2 liters of substrate are fed per day, the total amount of ingoing sulfate is then 2620 mg/day. This value is equivalent to 27.275 mmol/day.

According to the stoichiometry, one mole sulfate is converted to one mole sulfide so that similarly 27.275 mmol/day shall be produced in its most efficient state.

Considering the reactions stated in section 1.7.2, the amount of needed volume can be calculated for two different conditions:

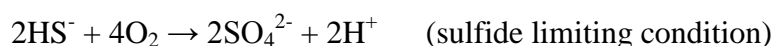

For oxygen limiting conditions: 13.638 mmol O₂/day ≈ 0.31 NL O₂/day

For sulfide limiting conditions: 54.55 mmol O₂/day ≈ 1.22 NL O₂/day

Due to the fact that oxygen limiting condition is mostly favored; assuming 20% oxygen in the air, the volume of the injected air is calculated as 1.51 NL/day.

However, 2 liters per day of aeration rate was selected to compensate the losses which are caused by transportation of injected oxygen to the gas collector (non sulfide-oxidizing oxygen).

Calculation of FeCl₃ dosage

- Following the stoichiometric equations presented in section 1.7.1 and considering the the amount of expected sulfide to be produced (see above section) the amount of FeCl₃·6H₂O added per day is calculated as:
27.275 mmol/day needs 18.183 mmol iron (III) to be precipitated. Therefore the amount of iron needed to precipitate the potential sulfide production is about 5 g/day [i.e. 18.183mmol x 270.33 (mg FeCl₃·6H₂O/mmol) = 4915.4 mg]. About 50% higher dosage was implemented as 7.32 g FeCl₃·6H₂O/day in order to get more rapid decrease.
- The maximum total amount of sulfide present in the reactor was estimated to be about 3000 mg including gas phase and liquid phase. 2500 mg of sulfide approximately corresponds to about 74 mmol. Following the calculation procedure presented above the amount of needed FeCl₃·6H₂O is calculated about 20 g FeCl₃·6H₂O/reactor.

Appendix IV (Additional graphs)

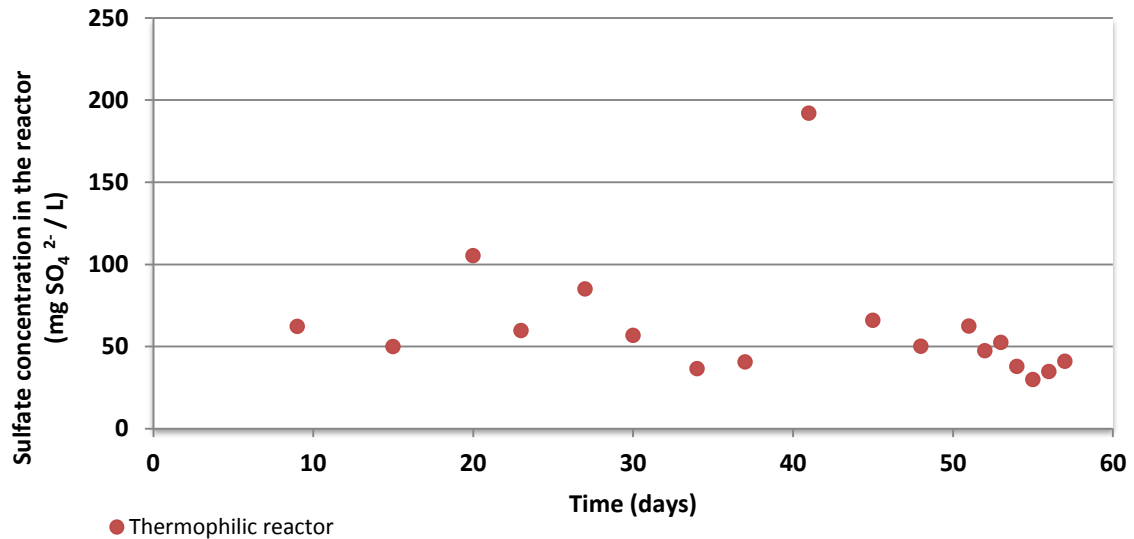

Figure a-1. Sulfate concentration in the thermophilic reactor. Data for the mesophilic reactor is not presented in this report due to high unreliability of measurements as described in the text.

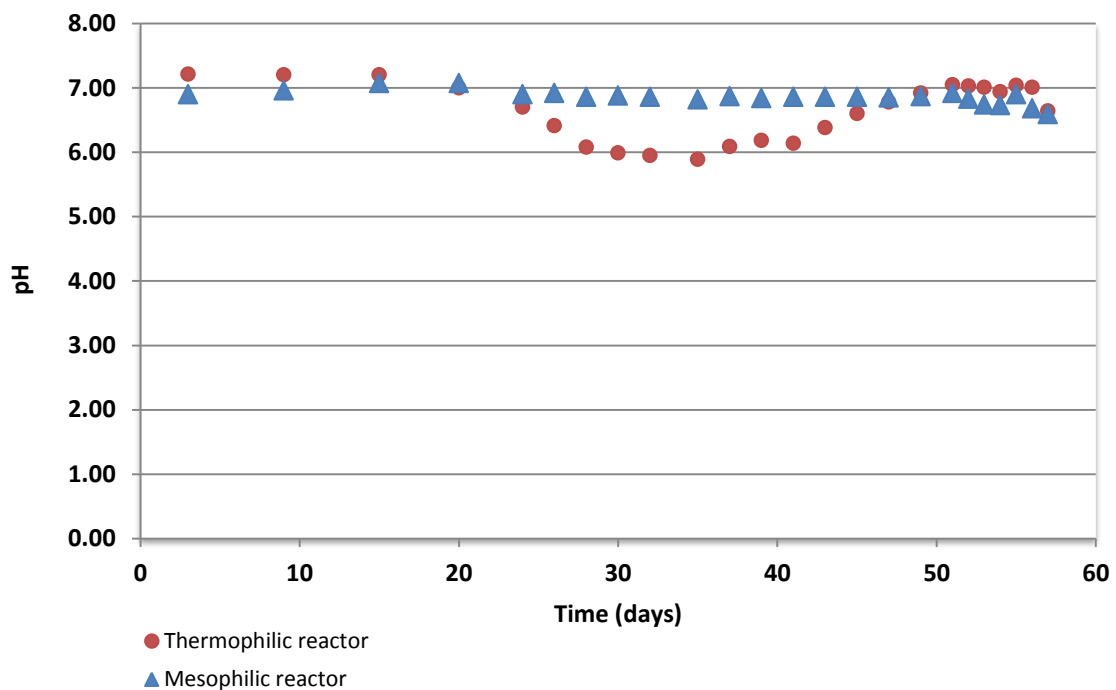

Figure a-2. pH variations during the experiment are shown in this figure. As shown, pH tends to decrease severely in the thermophilic reactor from day 18th because of accumulated acetate while the pH drop in the mesophilic reactor is found to be insubstantial.

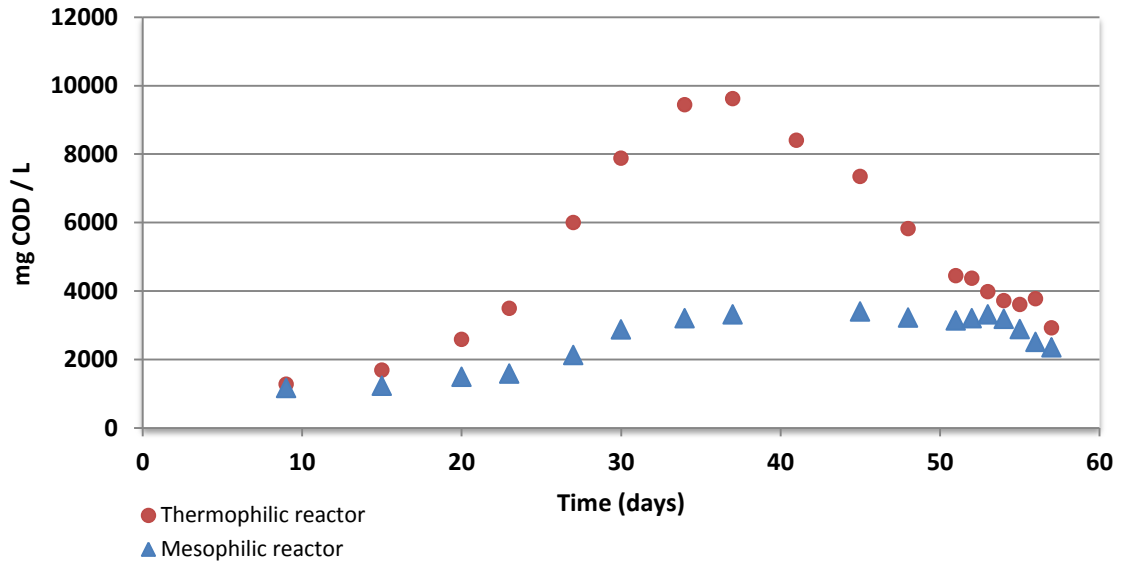

Figure a-3. Variations of dissolved COD throughout the experiment.

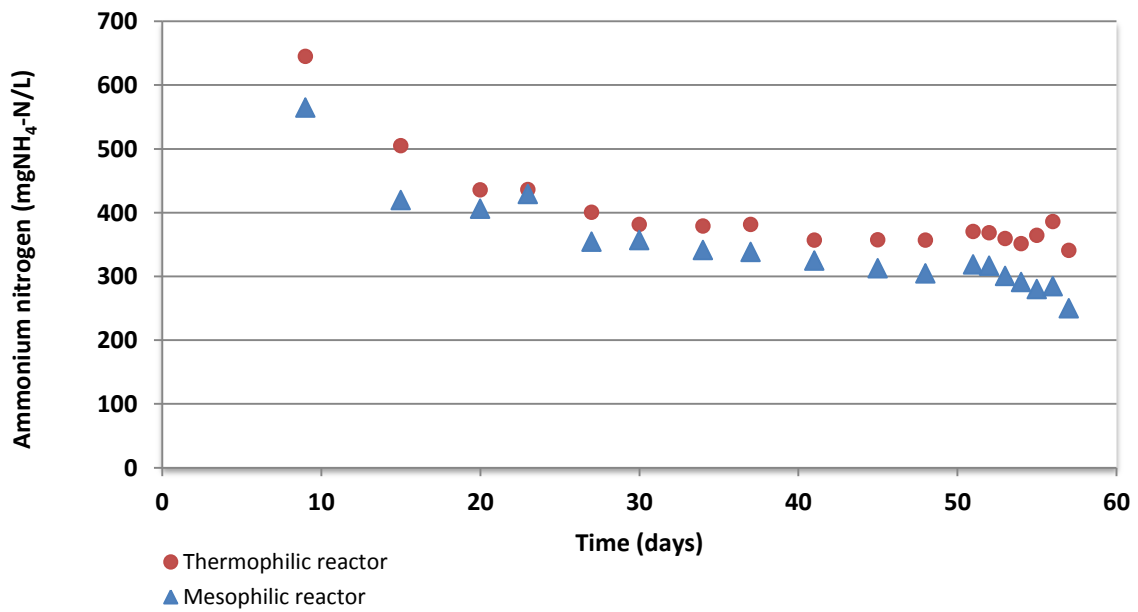

Figure a-4. Ammonium levels during the anaerobic digestion of enzyme pretreated algae.

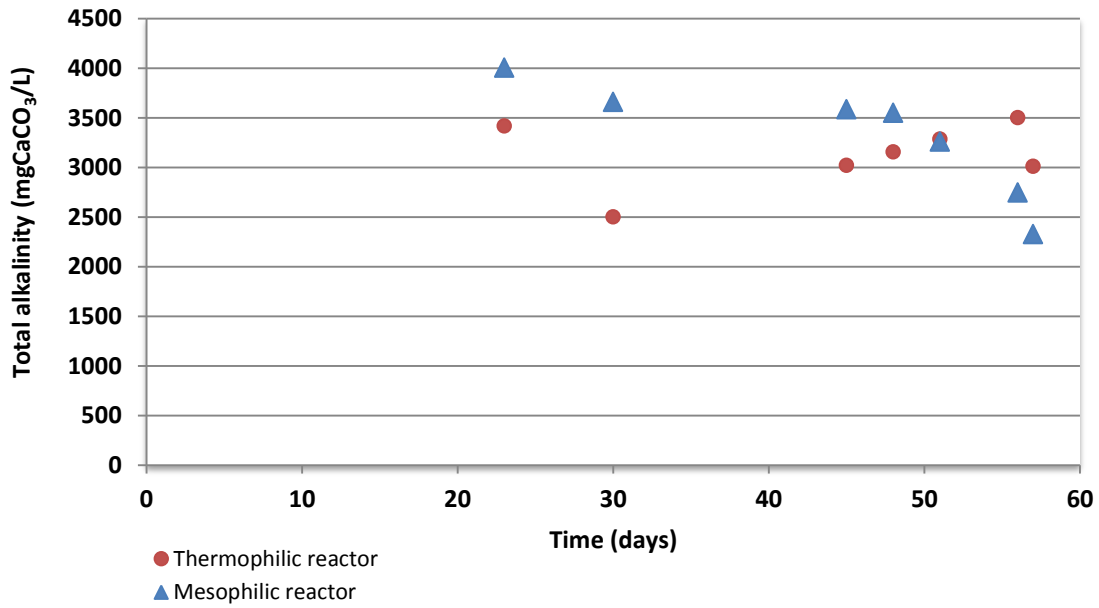

Figure a-5. Variations of total alkalinity calculated as mg CaCO₃/L during the experiment.

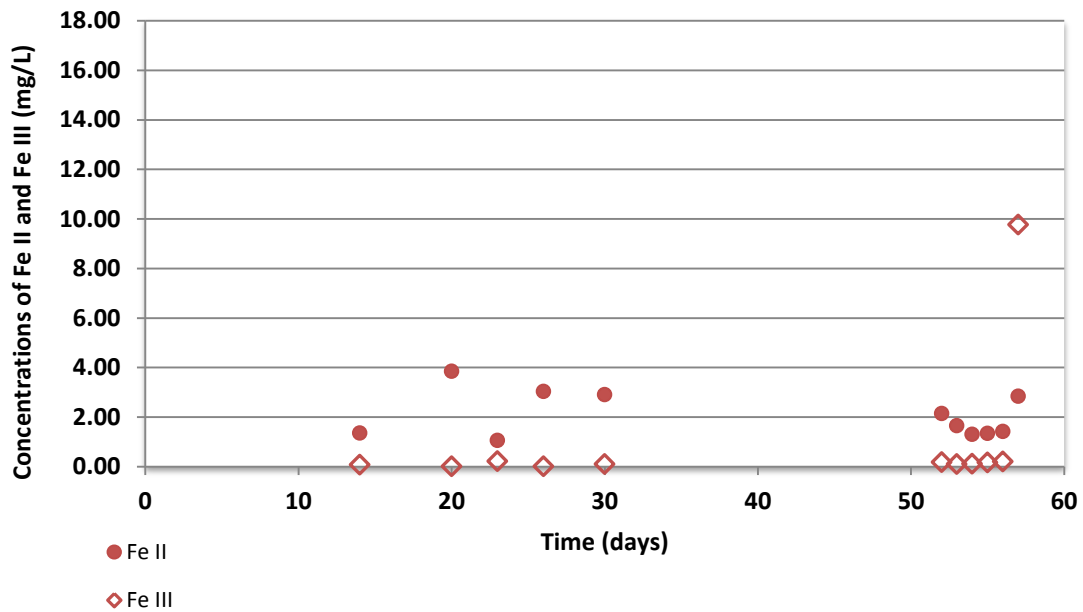

Figure a-6 Variations of Fe (II) and Fe (III) in the thermophilic reactor during the experiment. As it is seen, the concentration of Fe (III) is about 10 mg/L after addition of shock load of iron chloride while the concentration of Fe (II) is maintained at about previous levels. This is in agreement with findings of Khanal (2008) introducing divalent metals as suitable sulfide precipitators.

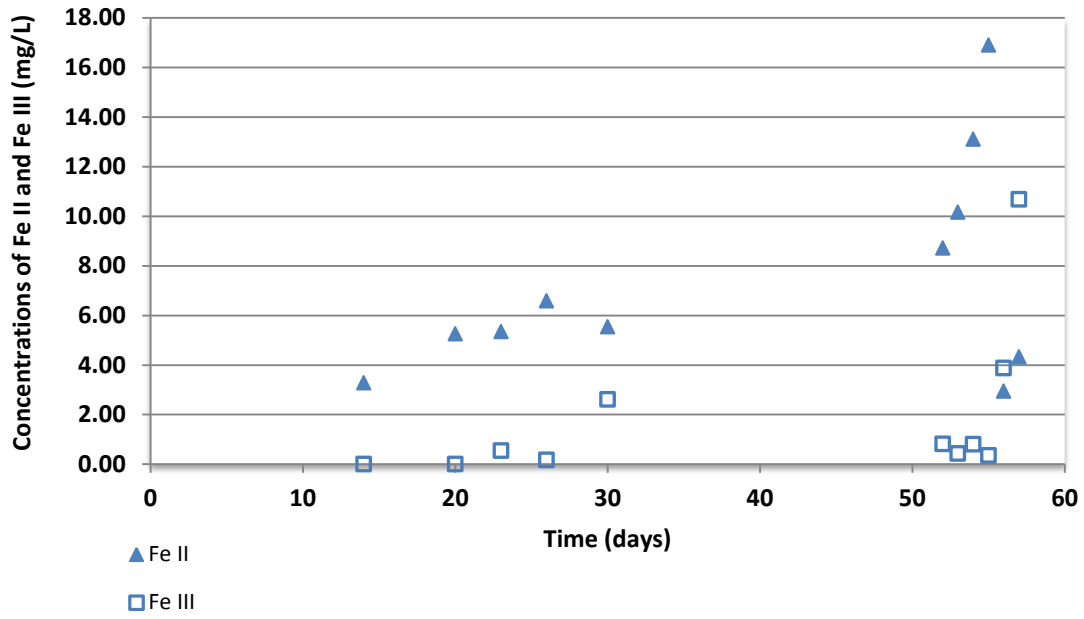
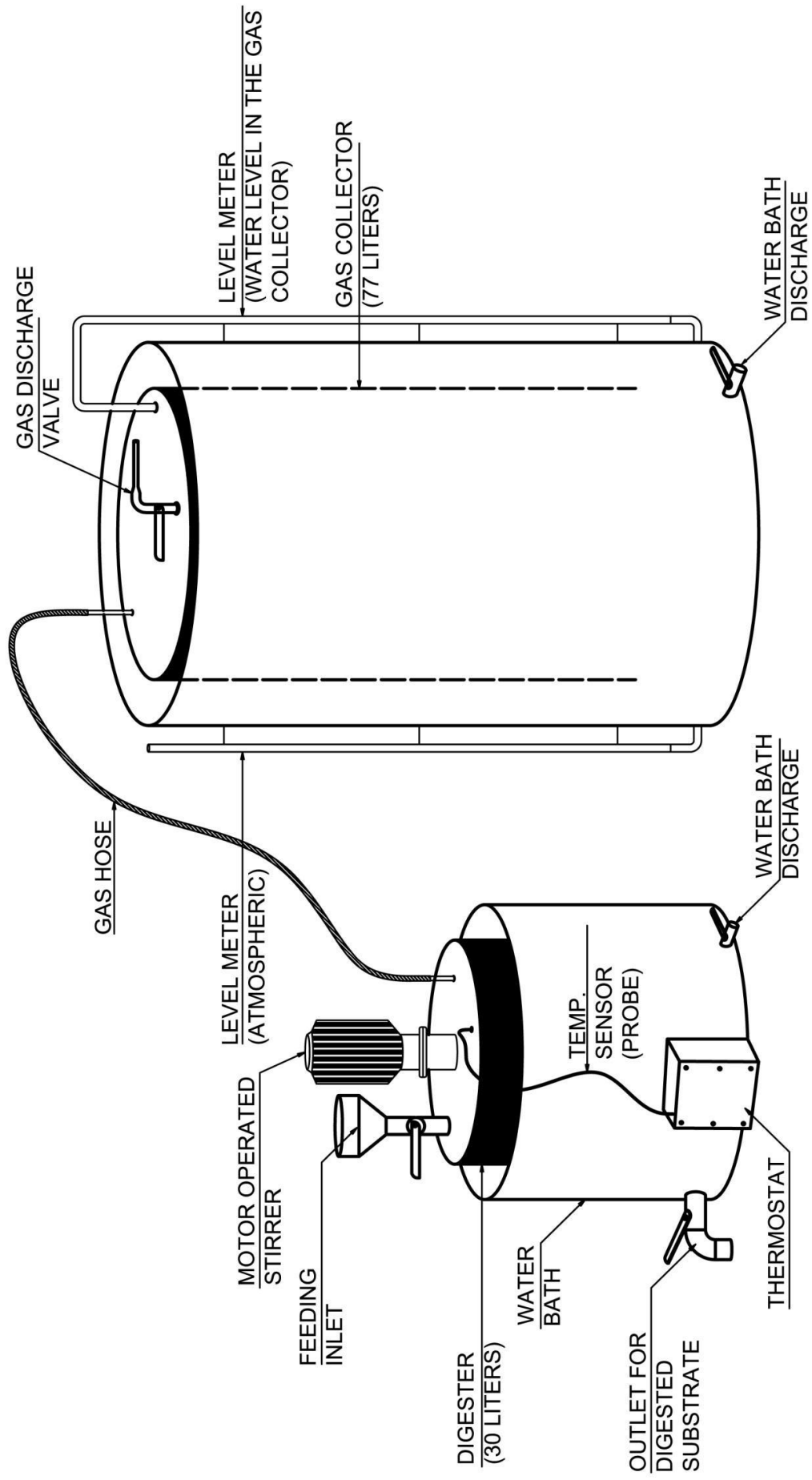

Figure a-7. Variations of Fe (II) and Fe (III) in the mesophilic reactor during the experiment. As described in the caption of Figure a-6, the amount of Fe (III) is higher than that of Fe (II) showing higher affinity of Fe (II) to sulfide. However, the trend during the last 3 days before addition of shock load is completely different showing higher concentrations of Fe (II).

Appendix V (schematic of the pilot set-up)



Management of hydrogen sulfide in anaerobic digestion of enzyme pretreated marine macro-algae

Salar Haghghatafshar

Department of Chemical Engineering, Lund University, Sweden

June 2012

Abstract

Enzymatic pretreatment of algae – by means of cellulose degrading enzyme – was evaluated through lab-scale and pilot-scale experiments. The degradation efficiency of the enzyme depended on the initial physical quality of the algae. Lab-scale batch anaerobic digestion experiments showed comparatively low methane potential for the pretreated algae at both mesophilic and thermophilic temperatures. However, the raw algae (cut into small pieces) were found to be hardly hydrolysable. The methane potential of raw algae in thermophilic and mesophilic digestion was about 17 NmL/gVS and – 36 NmL/gVS respectively. Presence of inhibitory agent(s) was obvious at both temperatures. Very fast growth of sulfate-reducing bacteria was noticed in the continuous digestion, so that in less than 20 days, hydrogen sulfide concentrations over 10000 ppm were observed in both meso- and thermophilic reactors. Inhibition of methanogenesis in the thermophilic reactor occurred at unionized dissolved sulfide concentration of about 22 mg/L (10000 ppm in the biogas) while it was mainly non-SRB acetogens that were inhibited in the mesophilic reactor at unionized sulfide concentrations as high as 50 mg/L (17000 ppm in the biogas). This shows that probably thermophilic digestion is more prone to be inhibited at high sulfide concentrations regarding methanogenesis. Micro-aeration was found to be more efficient in the thermophilic reactor while its effect on the mesophilic process was negligible.

Keywords: Anaerobic digestion, Sulfate, Hydrogen sulfide, Enzymatic pretreatment, Marine macro-algae, Micro-aeration

Introduction

Recent elevated demand for renewable energy as a substitute for fossil fuels has conducted attentions towards anaerobic digestion so that over 750 anaerobic digestion plants were installed between 1982 and 2002 all over the world [1]. However, obstacles such as hydrogen sulfide, high carbon dioxide content, presence of water vapor, slow hydrolysis rates under anaerobic conditions, and high sensitivity of anaerobic bacteria to

changes in wastewater composition; restrict the full industrial application of biogas [2][3].

Hydrogen sulfide production in the biogas from sulfur (sulfate)-rich wastewaters (substrates) may cause serious problems in application of biogas. Hydrogen sulfide, besides its unpleasant smell and corrosive nature which reduces the lifespan of pipework and other different installations in biogas industry, is also highly toxic to living beings. Among those living beings, microorganisms that produce methane through anaerobic

digestion are more vulnerable since they are openly exposed to sulfide concentrations. Thus, high concentrations of hydrogen sulfide may harm the digestion process prior to any other living organisms. So it is crucial to look for applicable methods and techniques in order to solve the hydrogen sulfide issue to be able to introduce new substrates into anaerobic digestion.

Accumulation of large piles of seaweed on beaches (Figure 1) may cause unpleasant odor [4] due to predomination of anaerobic conditions hence formation of gaseous sulfur-containing compounds such as hydrogen sulfide. The problem with accumulation of algae is not only restricted to bad odor but also some health problems may be caused by such emissions due to continuous inhalation of sulfide [5]. In order to meet the problem authorities collect the piled up seaweed on the beaches and store it temporarily during spring and summer and later on in autumn and winter release them back into the sea. Algae, however, can be used as fertilizer via spread on agricultural lands but its salinity, sometimes high cadmium (Cd) content and high amount of trapped sand limit such an application. Algae are introduced as toxic wastes in Sweden because of their sometimes high Cd content [6].



Figure 1. Piled seaweed on the Baltic coast, southern Sweden (Skåre)

Aim

In this study, technical feasibility of digestion of marine macro-algae through continuous anaerobic digestion was looked into. Different problems from collection and preparation of algae to the digestion process and produced biogas - both in quantity and quality - were taken into consideration. Additionally, evaluation of the problems caused by hydrogen sulfide was considered as a major aim in this study.

Since sulfide production is a biological process done by sulfate-reducing bacteria (SRB) which consume mutual substrates with methane-producing bacteria (MPB); changing process parameters such as solids retention time (SRT), temperature, pH, organic loading rate (OLR) for driving the competition towards the interest of methane producing bacteria (MPB), seemed to be extraordinarily interesting. However due to practical difficulties and limited available time, precipitation of sulfide via addition of external agents such as iron chloride and oxygen (micro-aeration) were tested.

Materials and methods

Two pilot-scale reactors located at Sjölanda wastewater treatment plant (Malmö) were used in the study operated at mesophilic (35°C) and thermophilic (55°C) temperatures. The reactors were equipped with stirrer operated continuously at a constant speed. Feeding substrate and withdrawal of digested matter were done manually once a day at a certain time. The temperature in the reactors was regulated by a thermostat connected to a heater. The digestion chamber was surrounded by a water bath which heated up the reactors. Produced biogas was collected in a bell-shape gas collector filled with water. Change in the water level inside the gas bells represented the differential pressure of the produced biogas. Schematic drawing of the reactors is shown in Figure 2.

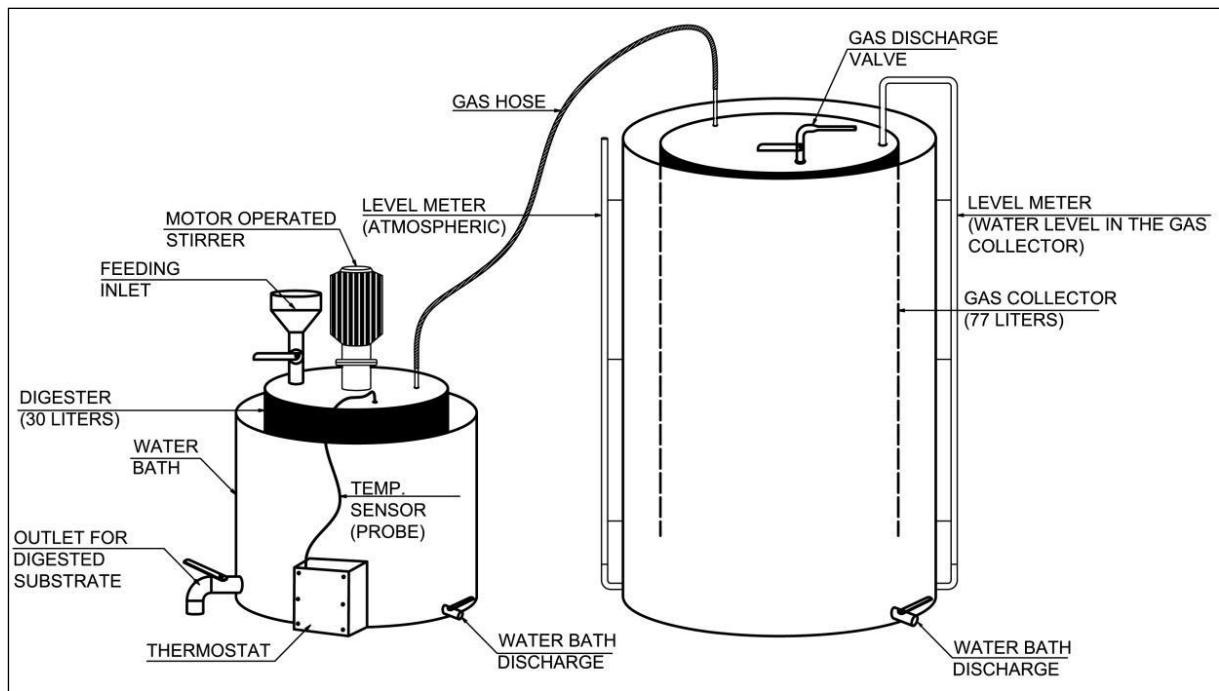

Figure 2. Schematic of the pilot-scale reactors used in the experiment

Some parameters of the digestion process as well as operational characteristics were measured in-situ at the location of pilot-scale reactors. pH of the digested matter from the reactors was measured using a digital pH-meter (pH 3110 SET 2 incl. SenTiz® 41) calibrated based on a two point-calibration at pH levels of 4 and 7. Gas fractions – including methane, carbon dioxide, oxygen and hydrogen sulfide (up to 2000 ppm) - were measured using a portable gas-meter. For higher hydrogen sulfide contents (above 2000 ppm), Dräger tube *Hydrogen Sulfide 0.2%/A* with order code of CH28101 was employed (range from 0.2 vol.-% to 7 vol.-%.)

Samples of digested matter as well as substrate were taken to the laboratories at Chemical Engineering Department / Lund University for further analyses. HACH LANGE test tubes were used for measuring COD (LCK 114), ammonium (LCK 303), sulfate (LCK 153), iron (LCK 320), and phosphate (LCK 049). Prepared tubes were analyzed with HACH LANGE spectrophotometer (model DR 2800).

All the samples stated above were centrifuged for 15 minutes at the speed of

10000 rpm and filtrated through *Munktell* general purpose filter papers with 6~10 μ m pore size before further analysis.

Furthermore, total solids (TS) content of digested matter and the substrate were measured after samples were dried for 24 hours at 105°C. Volatile solids (VS) content was estimated after burning the already dried samples at 550°C in 2 hours [7].

Methane production in lab-scale batch reactors was measured with gas-chromatograph -Varian 3800 Gas Chromatograph- equipped with TCD (thermal conductivity detector) and a column with the dimensions: 2.0m x 1/8 inch x 2.0mm. Volatile fatty acids (VFA) content of samples were analyzed with gas-chromatography using Agilent 6850 Series GC System equipped with FID (flame ionization detector) and a column with the dimensions: 25m x 0.32 μ m x 0.5 μ m.

The inoculum for the mesophilic reactor was taken from Öresundsverket wastewater treatment plant (WWTP)/ biogas plant (BGP) (operated at 35°C) and the thermophilic inoculum was collected from Kävlinge WWTP/BGP (operated at 55°C).

Needed algae for the experiment were collected at Skåre harbor, approximately 7 kilometers west of Trelleborg, southern Skåne – Sweden. Collected algal mass consisted of various species such as *fucus vesiculosus*, *fucus serratus*, *furcellaria lumbricalis*, *polysiphonia sp.*, *ceramium sp.* and *zostera marina* (not classified as algae). Mixture of algae had a TS of 15-25% from which between 75-80% was measured as VS fraction, depending on the moisture content of the batch.

Enzymatic pretreatment of marine algae was carried out using *Cellic® CTec2*. *Cellic CTec2* enzyme converts cellulose and hemicellulose, containing polymeric forms of sugar, into hydrolyzed fermentable monomers [8]. Accordingly, peak performance of the enzyme is obtained at 45-50°C and pH 5-5.5.

Results and discussions

Frozen algae were used for evaluation of enzymatic pretreatment in a lab-scale experiment. The pretreatment was done at 50°C for five days. Distilled water was added into the reactors after pretreatment ended in order to compensate the effect of evaporation; afterwards the content was sieved through 4 mm pore size sieve in order to obtain a homogenous matter. According to the results, higher dosages of enzyme have positive impacts on TS and VS content while a certain amount of COD and ammonium is obtained at all cases. Surprisingly it was observed that less sulfate is present in the reactors with higher dosages of enzyme. The same trend was seen for acetate as well. Similar decreasing trends for sulfate and acetate can probably be a sign for presence of acetotrophic sulfate-reducing bacteria utilizing both substrates to produce hydrogen sulfide. This has to be investigated furthermore because no anaerobic conditions were guaranteed during the experiment.

The substrate from enzymatic pretreatment was then digested in batch experiment at mesophilic (37°C) and thermophilic (55°) temperatures according to

the method for estimation of bio-methane potential (BMP) suggested by [8]. Digestion went on for approximately 50 days and the resulting methane yields are presented as Figures 3 and 4. The results of the experiment suggest very low net methane potential for both mesophilic digestion (12 Nml/gVS_{in}) and thermophilic (101.5 Nml/gVS_{in}) in comparison with municipal sewage sludge which normally gives yields around 400 Nml/gVS_{in} [9]. It should be noted that the methane potential values mentioned above are net values exclusive of the yield contributed by the added enzyme and of the inoculum.

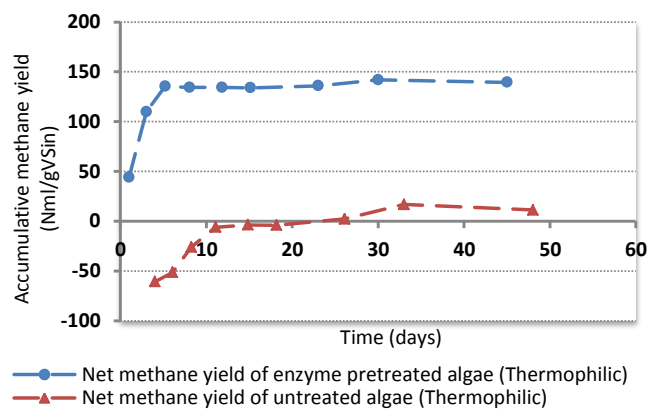

Figure 3. Accumulative methane production from thermophilic batch experiment (the enzyme pretreated algae comes from 30Enz5 reactor). About 40 Nml/gVS_{in} of the found methane potential is contributed by the added enzyme.

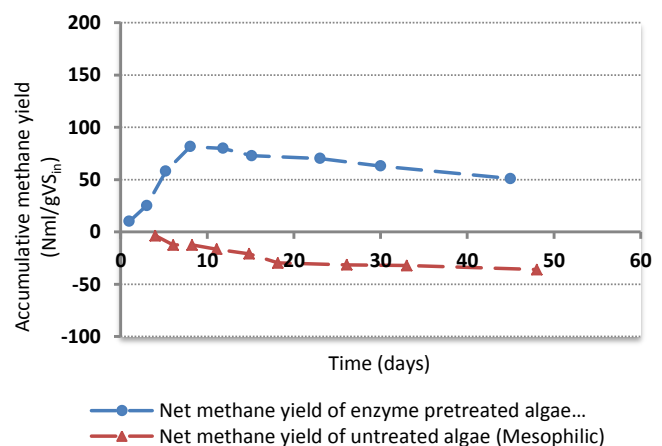

Figure 4. Accumulative methane production from mesophilic batch experiment (the enzyme pretreated algae comes from 45Enz5 reactor). About 40 Nml/gVS_{in} of the found methane potential is contributed by the added enzyme.

Observations as presented in figures above, demonstrate presence of strong inhibitory agent in the substrates. As it can be noticed in Figure 4, no considerable methane yield is found at mesophilic digestion of enzyme pretreated algae and the process was inhibited after 8 days of digestion when the yield reaches 82 Nml/gVS_{in}.

Digestion of untreated algae at mesophilic temperature was inhibited constantly leading to the methane potential of -36 Nml/gVS_{in}. This illustrates stronger inhibitory effect of the inhibition source in the untreated substrate.

At thermophilic batch digestion of enzyme pretreated algae, maximum yield is observed after 5 days of digestion about 135 Nml/gVS_{in} (Figure 3). Digestion of untreated algae at thermophilic temperature was also inhibited in the start of the process but later on showed a tendency for recovery as positive yields – although very small – were obtained. Reportedly, different derivatives of lignin, specifically aldehyde groups and those with apolar side chain, can be highly toxic to methanogens [11][12][13]. Presence of true lignin cells in a specific species of red algae - *Calliarthron cheilosporioides* – has also been reported [14]. Although there is a chance that lignin causes the inhibition; lack of data regarding cellular structure of the digested algae as well as degradability of lignin by means of the employed enzyme, makes it impossible to draw reliable conclusions.

Nevertheless analyses of reactors' content after digestion period of about 60 days indicate no inhibition of acetotrophic groups due to thorough VFA consumption in the batches with untreated frozen algae. In order to justify the phenomenon, two different speculations presented below may be considered:

- a) SRB outcompeted methanogens in competition over acetate due to higher amounts of sulfate released from un-

pretreated algae-i.e. lower COD/SO₄²⁻ ratio. On the other hand due to the fact that the methane yield in mesophilic reactor is negative could be another argument for the hypothesis. This could be in agreement with another study [15] demonstrating that at lower temperatures the amount of COD degraded by SRB increases. However it is not possible to verify the hypothesis since no hydrogen sulfide production was measured in the batches.

- b) Hydrolysis is reported to be the limiting step in anaerobic digestion. It seems very probable that the un-pretreated frozen algae have not been hydrolyzed sufficiently. Ocular examination of digestates from the batches also proved that not much was happened to the structure of the fed algae. Therefore it could be speculated that insufficient hydrolysis of algal mass (perhaps due to protective membranes) may have led to very low methane yield in thermophilic and negative yield for mesophilic batches.

Two digesters set at mesophilic (35°C) and thermophilic (55°C) temperatures were inoculated and fed with 2 liters of enzyme pretreated algae on daily basis. Disregarding the data from first 10 days, temperatures of the reactors were maintained throughout the experiment at 36.01±0.49 (°C) and 55.05±0.71 (°C) for mesophilic and thermophilic reactors, respectively. Methane production reached about 7 NL/day (about 400 NmL/gVS_{fed}) after 10 days of inoculation in both reactors. Meanwhile the concentration of hydrogen sulfide in the produced biogas was increasing rapidly so that over 10000 ppm was reached in less than 20 days (Figure 5).

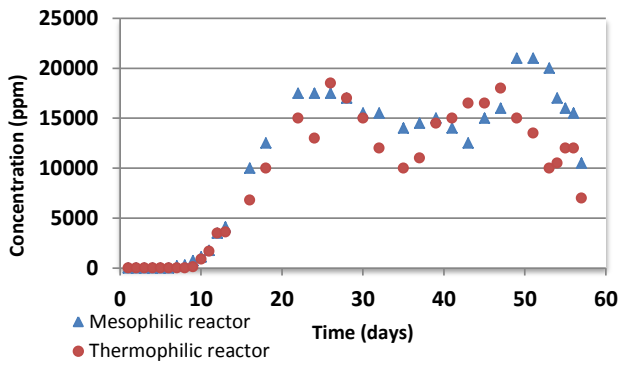

Figure 5. Hydrogen sulfide content of produced biogas measured as parts per million (ppm). For concentrations below 2000 ppm portable gas meter was used while for higher concentrations Dräger were employed.

Considering the data on methane yield (Figure 6) and accumulated methane production (Figure 7) it can be noticed that the major inhibition in the thermophilic reactor has occurred on day 18 while the significant drop in methane yield of the mesophilic reactor occurred a few days later on day 21 corresponding to about 22 mg/L (10000 ppm in gas phase) and 50 mg/L (17000 ppm in gas phase) of unionized dissolved sulfide, respectively. Earlier inhibition of methanogens in the thermophilic reactor, in spite of its lower sulfide content, demonstrates that methanogens are more prone to sulfide inhibition at thermophilic temperatures. However, stronger resistance of mesophilic reactor against higher sulfide concentrations can be a sign of acclimatization of the methanogens to high sulfide levels. This is very likely to be the reason in this case, since the inoculum for mesophilic reactor was taken from Öresundsverket which have had relatively high hydrogen sulfide content in the produced biogas for a long period of time.

Considerable consumption of acetate (Figure 8(a)) in the mesophilic reactor reveals that either both or at least one of the acetotrophic groups – methane producing bacteria or sulfate reducing bacteria – are not affected significantly by sulfide toxicity throughout the experiment. Studying the

propionate variation during the first 30 days of the experiment (Figure 8 (b)) suggests that propionate oxidation is also partly inhibited, perhaps because of high sulfide content. Since the amount of propionate in the thermophilic reactor is not considerable (700 mg COD/L), it can be mentioned that SRB are not considerably affected by sulfide toxicity. On the other hand, propionate accumulation in the mesophilic reactor is observed on day 27 and tends to increase up to about 1500 mg COD/L in 3 days (day 30). Also, a considerable drop in methane yield of the mesophilic reactor is noticed on day 22. The drop in methane yield (Figure 6) can therefore be linked to lack of acetate meaning that not sulfide toxicity, but insufficient oxidation of propionate causes the starvation of methanogens. In other words, inhibition of SRB is the reason for

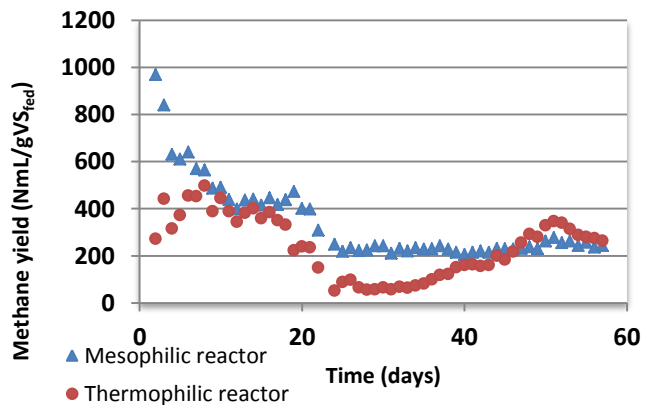

Figure 6. Methane yield as NmL/gVS_{fed} for thermophilic and mesophilic reactors.

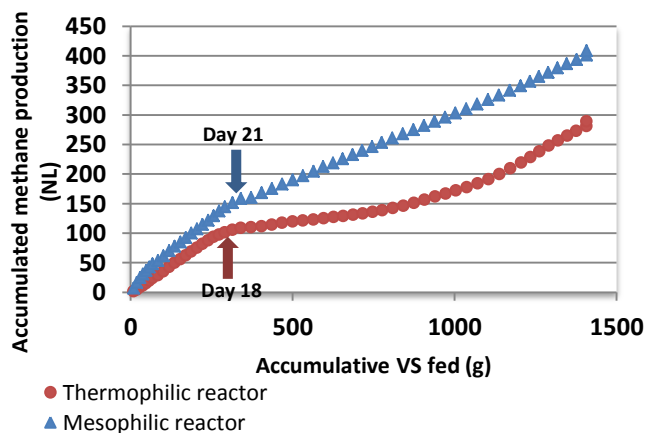

Figure 7. Accumulated methane production against accumulative VS fed is illustrated in this figure.

accumulation of propionate then a significant decrease in sulfide yield should have occurred as well. Nevertheless, normalizing the amount of hydrogen sulfide against the amount of sulfate fed per day shows that no significant reduction in sulfide yield is happened. This shows that no inhibition of SRB was taken place in the reactor.

Consequently, accepting that lack of acetate -due to incomplete oxidation of propionate- is the cause of methane yield drop, the effect of sulfide toxicity on non-SRB acetogens may be the reason. It is also reported that under sulfate rich conditions (small propionate/sulfate ratios) acetate is most favored by SRB [16]. This, somehow, explains high degradation level of acetate in the mesophilic reactor.

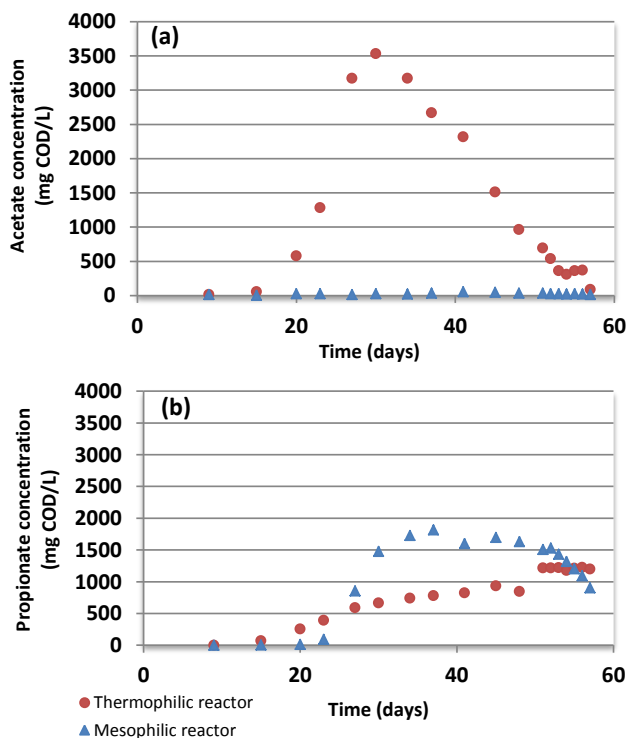

Figure 8. Volatile fatty-acids concentration during the experiment.

As a sulfide treatment method, micro-aeration started to be applied at the rate of 2 liters air per day, injected into the reactors' headspaces starting on day 23. As it can be

seen from the data presented in Figure 5, the thermophilic reactor had a better efficiency in sulfide reduction via aeration. Hydrogen sulfide fraction decreased considerably in about 12 days from about 18000 ppm down to 10000 ppm. It should be noted that the inhibition in thermophilic reactor due to sulfide toxicity occurred at around 10000 ppm.

During the same period (from day 23 to 35), the methane yield was leveled out at about 65 NmL CH₄/gVS_{fed} more or less unaffected (see Figure 6). After this period, methane yield tended to increase gradually until day 50, having recovered the yield to about 330 NmL-CH₄/gVS_{fed}. Simultaneously hydrogen sulfide production in the thermophilic reactor increased as well.

Unlike the thermophilic reactor, the effect of micro-aeration in the mesophilic reactor is negligible. The decrease observed in hydrogen sulfide content of biogas can be linked to the dilution of gas due to injection of air (about 13%). However the amount of oxygen consumed per day was calculated about 300 NmL/day (approximately 75% of the injected oxygen was consumed while the value for the thermophilic reactor was found to be about 62%). The methane yield for the mesophilic reactor remained unchanged during micro-aeration period (see Figure 6).

It was also speculated that micro-aeration enhances the TS and VS reduction. This could be linked to the improved hydrolysis rate under micro-aeration conditions as reported by [17]. It seems that it is the developed TS reduction that leads to rises in methane yield and sulfide production. However, further investigations are needed to check whether it is the positive effect of micro-aeration on TS reduction or it is simply adaptation of new substrate with higher TS content.

Conclusion

Comparative batch experiments with enzyme pretreated algae and untreated frozen cut algae, revealed that hydrolysis of untreated algae takes place at minor rates, especially at

mesophilic temperatures. Additionally presence of an inhibitory agent in digestion of untreated algae was suggested.

Digestion of enzyme pretreated algae in continuous digestion showed relatively acceptable methane yields (about 400 NmL CH₄/gVS_{fed}) for both thermophilic and mesophilic reactors before inhibition occurred due to high hydrogen sulfide levels. Inhibition of methanogens by sulfide toxicity was only observed in the thermophilic reactor despite the fact that the level of dissolved sulfide was lower according to Henry's law at thermophilic temperatures. Methanogenesis inhibition in the thermophilic reactor – linked to considerable acetate accumulation - was initiated at dissolved sulfide concentration of 22 mg/L (10000 ppm H₂S in gas phase) while the SRB were found to be unaffected. No sulfide toxicity on SRB was observed in the mesophilic and thermophilic reactors. Relatively more resistant methanogens in the mesophilic reactor may have been a result of acclimatization.

Micro-aeration of the thermophilic reactor at the rate of 2 liters of air per day led to improvement of methane yield up to about 330 NmL CH₄/gVS_{fed} although smaller amounts of dissolved oxygen were expected. Oppositely, the mesophilic reactor remained more or less unaffected regarding the methane yield during the micro-aeration period.

Acknowledgements

All the experiments stated in this study were done as the Master's thesis at Water and Environmental Engineering at the Department of Chemical Engineering Lund University. Thanks to the supervisor and examiner of the thesis Åsa Davidsson and Jes la Cour Jansen who have always been helpful providing answers to questions; as well as solutions to various practical obstacles all throughout the study. Thanks to VA SYD for providing the pilot-scale reactors and the workshop. I would also like to thank Ellinor Tjernström from the

municipality of Trelleborg who helped a lot in locating and identifying the algae.

References

- [1] Kassam, Z. A., Yerushalmi, L. , Guiot, S. R., (2003). A Market Study on the Anaerobic Waste-water Treatment Systems. *Water, Air, and Soil Pollution*, 143, 179-192.
- [2] Noyola, A., Morgan-Sagastume, J. M. & López-Hernández, J. E. (2006). Treatment of Biogas Produced in Anaerobic Reactors for Domestic Wastewater: Odor Control and Energy/Resource Recovery. *Reviews in Environmental Science and Bio/Technology*, 5, 93-114.
- [3] Leitão, R. C., Van Haandel, A. C., Zeeman, G. & Lettinga, G. (2006). The effects of operational and environmental variations on anaerobic wastewater treatment systems: A review. *Bioresource Technology*, 97, 1105-1118.
- [4] Charlier RH, Morand P, Finkl CW, Thys A. (2007). Green tides on the Brittany Coasts. *Environmental Research, Engineering and Management* 3(41):52–59
- [5] Peu P., Sassi, J. F., Girault R., Picard S., Patricia Saint-Cast, Béline F., Dabert P., (2011). Sulphur fate and anaerobic biodegradation potential during co-digestion of seaweed biomass (*Ulva* sp.) with pig slurry. *Bioresour. Technol.* 102, 10794-10802.
- [6] Nkemka V. N., Murto M., (2010). Evaluation of biogas production from seaweed in batch tests and in UASB reactors combined with the removal of heavy metals. *Journal of Environmental Management* 91, 1573-1579.

- [7] Swedish Institute for Standards (2000). Characterization of sludge – determination of dry residue and water content (SS-EN 12880) and determination of loss on ignition of dry mass (SS-EN 12879).
- [8] Novozyme, (2010). Novozymes Cellic® CTec2 and HTec2 - Enzymes for hydrolysis of lignocellulosic – Application sheet.
- [9] Hansen, T.L., Schmidt, J.E., Angelidaki, I., Marca, E., Jansen, J.la C., Mosbæk, H., Christensen, T.H., (2004). Method for determination of methane potentials of solid organic waste. *Waste Management* 24, 393–400.
- [10] Davidsson, Åsa, (2007). Increase of Biogas Production at Wastewater Treatment Plants Addition of urban organic waste and pre-treatment of sludge, Ph.D. Thesis, Dept. of Water and Environmental Engineering, Lund University.
- [11] Benjamin, M.M., Woods, S.L., Ferguson, J.F., (1984). Anaerobic toxicity and biodegradability of pulp mill waste constituents. *Water Res.* 18, 601–607.
- [12] Sierra-Alvarez, R. and Lettinga, G., (1991). The methanogenic toxicity of wastewater lignins and lignin related compounds. *J. Chem. Technol. Biotechnol.*, 50: 443–455.
- [13] Chen, y., Cheng, J. J., Creamer, K. S. (2008). Inhibition of anaerobic digestion process: a review. In: *Biores. Technol.* 99, 4044-4064.
- [14] Martone, P. T., Estevez, J. M., Lu, F., Ruel, K., Denny, M. W., Somerville, C. & Ralph, J. (2009). Discovery of lignin in seaweed reveals convergent evolution of cell-wall architecture. *Current biology: CB*, 19, 169-175.
- [15] Shin, H. S., Oh, S. E., and Bae, B. U., (1996). Competition between SRB and MPB according to temperature change in the anaerobic treatment of tannery wastes containing high sulfate. *Environ. Technol.* 17, 361–370.
- [16] Uberoi, V. and Bhattacharya, S. K., (1995). Interactions among sulfate reducers, acetogens, and methanogens in anaerobic propionate systems. *Wat. Environ. Res.* 67, 330–339.
- [17] Tartakovsky, B., Mehta, P., Bourque, J., Guiot, S.R., (2011). Electrolysis-enhanced anaerobic digestion of wastewater. *Bioresour. Technolog.* 102, no. 10, pp. 5685-5691.