

# By-Products from production of Formaldehyde for Haldor Topsøe

by

Åse Trulsson

Department of Chemical Engineering  
Lund University

June 2015

Supervisor: **Assoc. prof. Christian Hulteberg**

Co-supervisor: **Laura Malek. MSc**

Co-supervisor: **Mads Kaarsholm, PhD (Haldor Topsoe A/S)**

Examiner: **Prof. Hans T. Karlsson**

---

**Postal address**

P.O. Box 124  
SE-221 00 Lund, Sweden

**Web address**

[www.chemeng.lth.se](http://www.chemeng.lth.se)

**Visiting address**

Getingevägen 60

**Telephone**

+46 46-222 82 85

+46 46-222 00 00

**Telefax**

+46 46-222 45 26







# Preface

This master theses have been possible thanks to Haldor Topsøe. A great thank to my supervisor Christian Hulteberg that helped me find my masters theses and helped guide my through the proses. I also owe a great thanks to Laura Malek for putting up with being disturbed by me often and a lot. These two as well as everyone else at the department of chemical engineering on +1 have been great in keeping my mood up when things were not going to great and helping to get things to work.

I would also like to thank Mariano Massa for the help and support of how the GC worked, even though it was not used.

Of course a great thanks to the people who have studied with me for 5 years and other friends for making the time at university so fun. Epically to my office mates Victor Gustafson and Øyvind Nørregård. My family, for never stopping to believe in me. Även ett speciellt tack till min mormor och morfar för ett intresse i vad jag gör, stöd och support på så många stadier.



# Abstract

Formaldehyde is an important chemical which is used as an intermediate and for the production of urea-formaldehyde, which is used in the production of plywood. The purpose of this report is to investigate to how impurities in methanol, that is the raw material in formaldehyde production, will affect the production. This report have mainly looked at how the impurities affect the by-products. This project is done in collaboration with Haldor Topsøe A/S (HT).

To be able to study the production an experimental set-up had to be made. It was executed in the attempt to be as close to an HT formaldehyde plant as possible. The different impurities were added one by one and then a mixture of the components were made. The production stream were analyzed by a mass spectrometer (MS).

In all experiment the different impurities were added one-by-one. The impurities that were used were: ethanol, higher alcohols (1-butanol and 2-propanole), methyl formate (MF) and acetone. In all the experimental cases an increase in dimethyl ether (DME) concentration could be seen and for nearly all impurities an increase in dimetoxy methane (DMM) was also detected. The same results could be seen for the mixture, in which all the impurities were added. This means that the different impurities does not seem to react with one another. DME and DMM will not be a problem since DME already exist as a by-product today, and DMM would most likely react back to methanol and formaldehyde in the acidic environment which exist in the absorption tower.





# Sammanfattning

Formaldehyd är en viktig övergångskemikalie som bland annat används för produktion av urea-formaldehyd, vilket i sin tur används för att tillverka plywood. Syftet med denna rapport är att titta på hur produktionen av formaldehyd påverkas då olika föroreningar existerar i metanolen som används som råmaterialet. Projektet ämnar att främst titta på hur bi-produkterna varierar då olika föroreningar som existerar i rå-metanol tillsätts, projektet är gjort åt Haldor Topsøe (HT) vägnar.

För att studera produktionen har en försöksrigg byggts upp i laborativ skala, där den verkliga processen så mycket som möjligt försökts efterliknas. De olika föroreningarna tillsattes en och en, där efter gjordes en blandning innehållande de föroreningarna som studerats. De utgående flödet ifrån försöksriggen analyserades av en masspektrometer (MS).

I alla experiment var föroreningarna först adderade en och en. Föroreningarna som användes var: etanol, högre alkoholer (1-butanol samt 2-propanol), metyl formeat (MF) samt aceton. Alla experiment gjorda med föroreningar visade en tydlig ökning av dimetyleter (DME) samt i det flesta fall även en ökning av dimetoxymetan (DMM). Samma resultat erhöles när alla orenheter blandades i en blandning, vilket betyder att föroreningarna inte verkar reagera med varandra. Föroreningarna DME samt DMM är föroreningar som inte bör störa produktionen av formaldehyd i en HT process. Detta för att DME redan existerar i processen idag som en bi-produkt, och DMM kommer med största sannolikhet reagerar tillbaka till metanol samt formaldehyd i den sura miljön som existerar i absorptionstornet.



# Table of Contents

1	Introduction .....	1
1.1	Aim .....	1
1.2	Scope.....	1
1.3	Structure.....	2
1.4	Limitations .....	2
1.5	Company .....	2
2	Theoretical Background .....	3
2.1	Formaldehyde .....	3
2.2	Methanol .....	4
2.3	Production Background .....	5
2.4	Production Today.....	6
2.5	Catalysts.....	9
2.6	Kinetics .....	10
2.7	Overview of Laboratory Experiments .....	12
3	Method .....	13
4	Experimental Part.....	14
4.1	Experimental setup .....	14
4.2	Flows.....	15
4.3	MS Analysis.....	16
5	Result and Discussion .....	17
5.1	Blank experiment.....	17
5.2	Pure Methanol.....	18
5.3	Ethanol .....	20
5.4	Higher Alcohols .....	20
5.5	Methyl Formate.....	21
5.6	Acetone .....	21
5.7	Crude Methanol .....	22
5.8	Catalyst .....	23
5.9	Social & Ethical Aspects .....	24
6	Conclusion.....	25
7	Future Work .....	26
8	References .....	27
9	Abbreviations .....	29
10	Appendices .....	I
	Appendix A .....	I

Appendix B .....	II
Appendix C .....	VI

# 1 Introduction

Formaldehyde is an important intermediate chemical, both for its potential as a C1 building block and from an economic point of view [1-12]. This master's thesis is done in collaboration with Haldor Topsøe A/S (HT) and regards the production of formaldehyde for methanol oxidation, that today uses methanol of grade AA [1]. This report have looked into if it would be possible to use crude methanol for the production and how this would affect the production. This is important because of the increasing prices of methanol and that methanol is standing for the majority of the production price of formaldehyde [13, 14]. Using a crude methanol instead of a more purified one would lower the production cost of formaldehyde.

## 1.1 Aim

The aim of this master's thesis is to investigate whether crude methanol could replace the grade AA (used today) as feedstock for production of formaldehyde by oxidation. The project will study how the different contaminations in the crude methanol affects the production of formaldehyde and understanding the problem such a feedstock could bring. Special focus will lie on the following aspects:

- Quality of formaldehyde
- Conversion
- Yield
- Selectivity of catalyst

A commercial catalyst will be used for the project and the last point, selectivity of catalyst, will focus on the appearance of the following substances:

- Dimethyl ether (DME)
- Methyl formate (MF)
- Dimethoxy methane (DMM)
- Carbon monoxide (CO)
- Carbon dioxide (CO<sub>2</sub>)

## 1.2 Scope

The project have looked in to the production of different by-products, see 1.1 Aim. The by-products that have been looked at are formed when using a commercial catalyst and having different impurities in the methanol. The outgoing stream has been analyzed with the help of analytical equipment, in this case a mass spectrometer (MS). The impurities were first looked at one-by-one too see if there were any major activities for one special element. Then a mix with all of the chemicals were made and tested. The different impurities that have been looked at are:

- Ethanol
- Higher Alcohols
  - 1-butanol
  - 2-propanol
- MF
- Acetone

### **1.3 Structure**

The thesis will have the following structure, it will start with a theoretical background section, which is the result from the literature study. Followed by the method and continue on with the experimental setup where the experimental method used is described. This is followed by the results, a discussion and conclusion, at the very end references, abbreviations and appendices can be found.

### **1.4 Limitations**

Because this project has been done as a master's thesis there has been a time limitation on the project. It is recommended that a master's thesis takes 20 weeks and that has been the timeframe for this project. There have also been some limitations to what analytical equipment that has been available, as well as chemicals and gases. Therefore an MS will serve as the analytical instrument, the limitations for the MS is that at low values (ppm) the results will not be probable because there will be noise that disturbs the readings. Another thing that is negative with the MS is that one only sees what one is looking for. If any additional by-products have been produced they might not have been considered as this might not be noticed with an MS. For feeding the methanol to the system a syringe and a syringe pump was used. The calibrations for the methanol flow had to be done by hand, this is hard because the liquid flow is very small. Because the calibration is done to atmospheric pressure and then is fed in to the reactor where gases flow by it is impossible to know if exactly the same flow is going in to the reactor.

### **1.5 Company**

HT is a Danish company that is specialized in catalysis and are one of the leading companies in this field. The company was founded in 1940 by Dr. Haldor Topsøe. The first produced catalyst by the company was for the production of sulfuric acid in 1944. Catalyst production started in Fredrikssund, Denmark, in 1959. HT is a global company with over 2,800 employees worldwide [15]. Catalysts are very important in today's industrial world and more than 80 % of industries worldwide use catalyst for their productions, catalyst are especially important in the chemical industries [16].

## 2 Theoretical Background

### 2.1 Formaldehyde

Formaldehyde, CH<sub>2</sub>O, is one of the world's most important chemicals, both because of its significance as an intermediate chemical and from an economic point of view [1-12]. Most of the produced formaldehyde, 55 %, goes towards the production of resins, for example urea-formaldehyde that is used in production of plywood boards. Another use is as an intermediate in the production of other chemicals where formaldehyde works as a C1 building block, for example to synthesize 1,4-Butanediol and trimethylolpropane. Other products where formaldehyde works as a building block is for the production of dyes, flavoring and drugs [1, 2]. Formaldehyde is also used for other things for example within healthcare, both in higher concentration as disinfectants and as diluted systems for microscopic usage. It is also used in agricultural context as a fertilizer [1-7, 17]. It can be found in combustion gases or in cigarette smoke, because formaldehyde can be formed from incomplete combustion of organic material [1, 4, 7, 8]. But industrially formaldehyde is produced from methanol, however there are ways of producing formaldehyde from alternative raw materials such as methane or propane. Production from alternative raw materials, such as methane or propane, are not as profitable and therefore not used in industrial scale or described in this report [1, 2, 4, 7, 8, 10].

#### 2.1.1 Physical and Chemical Properties

Formaldehyde is at normal conditions, room temperature and atmospheric pressure, a colorless gas but has a distinctive odor that can be irritating. It has been classified as probably a carcinogenic chemical [1-4, 7, 8]. Formaldehyde liquefies at -19.2 °C and solidifies as a white paste at -118 °C, which can be seen in Table 2.1 with some other physical and chemical properties for formaldehyde [1, 8, 17]. The gas is easily dissolved in water and a solution can consist of up to 52 wt% formaldehyde, commercially it consists of 37 wt% [2-4]. To preserve solutions of formaldehyde, the hydrate of formaldehyde is added as well as methanol to maintain stability. When stored too long, polymerization can occur anyway, generally as paraformaldehyde which precipitates as a white powder. It is also important to think of the temperature when storing formaldehyde. If too high temperature, formic acid could start to be produced [1, 3, 8].

Table 2.1. Physical and chemical properties of formaldehyde [1, 2].

<b>Property</b>	<b>Value</b>
<b>Boiling point</b>	-19.2 °C
<b>Melting point</b>	-118 °C
<b>Ignition temperature</b>	430 °C
<b>Critical temperature for flammability in air</b>	137.2 – 141.2 °C
<b>Flammability and explosive lower/upper limits (in air)</b>	7/73 mol%

At 150 °C formaldehyde starts to heterogeneous decompose to forms methanol and carbon dioxide. If it reaches 350 °C or higher it will decompose into carbon monoxide and hydrogen gas. The production of methanol, formic acid, CO<sub>2</sub>, methyl formate (MF) and methane can become catalyzed by metals such as copper, platinum, chromium and aluminum [1]. Transporting formaldehyde long distances is expensive and hard, it is therefore normally produced on site [10]. If transported, it is important that it is contained right, preferably in a steel container, as well as keeping the right temperature or by-products will start to form [1, 2]. Formaldehyde production, globally, was about 27 million metric tons per year in 2010 and have had a steady increase the last two decades [8].

Formaldehyde together with air is both a flammable and an explosive mixture, at room temperature [1, 8, 17]. At this temperature the lower and upper explosive limits for a mixture of formaldehyde together with air are 7 respectively 72 vol%. The same limits are valid for the flammability at formaldehyde in air [1, 2, 17]. Formaldehyde is a very reactive compound, and has an ignition temperature of 430°C [1, 2, 7].

## **2.2 Methanol**

Methanol is an important intermediate chemical, for example for the production of formaldehyde. 85% of all produced methanol is used as an intermediate of other chemicals [18], and 35% of the produced methanol is used for the production of formaldehyde [18-20]. Methanol is both flammable and explosive when mixed with air, with a lower limit at 6 vol% and an upper limit of 36 vol% for both cases. Production started in 1923 at BASF in Germany where they used a zinc-chromium oxide as their catalyst. The catalyst required high pressures, 250 – 350 atm and temperatures of 320 – 450 °C [18, 20]. Today methanol is produced by synthetic gas conversion with the help of a catalyst which is based on copper. This process was developed by ICI in the 1960s, and uses a low pressure principle with pressures of 50 – 100 atm [18, 19].

Methanol is produced for commercial purposes with three kinds of purity, Grade A, Grade AA and IMPCA. The main difference between Grade A and AA is the allowed content of water, ethanol and acetone. Grade A is mostly used as a solvent and Grade AA is most applied for production of hydrogen and carbon dioxide [18, 20], but also formaldehyde [1]. What the three different grades contain and how much it contains of the different substances can be seen in Table 2.2.



Table 2.2. The three commercial purity's of methanol, grade A, grade AA and IMPCA and what impurities they contain as well as the quantity of these. The values are taken from Ullman's Encyclopedia of industrial chemistry [18].

<b>Property</b>	<b>Grade A</b>	<b>Grade AA</b>	<b>IMPCA</b>
<b>Methanol content [wt%]</b>	> 99.85	> 99.85	> 99.85
<b>Water content [wt%]</b>	< 0.15	< 0.10	< 0.10
<b>Ethanol content [mg/kg]</b>		< 10	< 50
<b>Aceton content [mg/kg]</b>	< 30	< 20	< 30
<b>Acid content (as acetic acid) [mg/kg]</b>	< 30	< 30	< 30
<b>Chloride as Cl<sup>-</sup> [mg/kg]</b>			0.5
<b>Sulfur [mg/kg]</b>			0.5
<b>Total iron [mg/kg]</b>			0.1
<b>Hydrocarbons</b>			Pass test

Methanol that is obtained directly after synthesis, before purification, is sometimes used and is called crude methanol. It contains longer alcohol chains and esters, MF and 5 – 20 vol% of water. This crude methanol is not commercially available and the amount and types of impurities depends on how the methanol is synthesized. This un-pure methanol can be used as fuel or for the production of fuels and specific chemicals, for example it can be used for the production of dimethyl ether (DME) [18].

## 2.3 Production Background

In 1859 the first successful attempt to synthesize formaldehyde was done by Butlerov. The way he managed to do this was by hydrolyzing methylene acetate. Hofmann produced and identified formaldehyde in 1867 close to the way formaldehyde is proceeded today. The way he went about producing formaldehyde was by letting methanol vapor and air flow over a heated platinum spiral [1, 7, 17]. It was not described how pure formaldehyde was prepared until 1882 when Kekulé took to pen and paper and wrote it down [1]. To industrially produce formaldehyde became possible first in 1862 thanks to the developments of equipment by Lowe [7, 17], who also changed the catalyst from platinum to copper gauze [17]. In 1889 the first commercial production plant became finished and the market begun, also here utilizing copper as catalyst [1, 7, 8]. The silver catalyst, still in use today, got its start in 1910 by the help of Hugo Blank. Formaldehyde was not produced on a true industrial scale until 1925 when the development of a high pressure synthesis of methanol was taken forth by Badische Anilin & Soda-Fabrik (BASF) [1, 7].

In 1921 another process was patented by G. C. Bailey and A. E. Craver, this one based on oxidation of methanol to formaldehyde, were they used a vanadium pentoxide catalyst. This was followed by an iron oxide–molybdenum catalyst in 1933 that was patented by V. E. Meharg and H. Adkins. The oxidation process was not applied commercially until 1952 when the first plant using the iron/molybdenum catalyst was put into operation. The Mo:Fe is still the commercially catalyst for oxidation processes [2, 7, 9, 12, 21].

## 2.4 Production Today

Today two main processes are in use for the production of formaldehyde from methanol, the silver process and the oxide process. The first can be divided in to two processes, the methanol ballast process and the BASF process, se Figure 2.1.

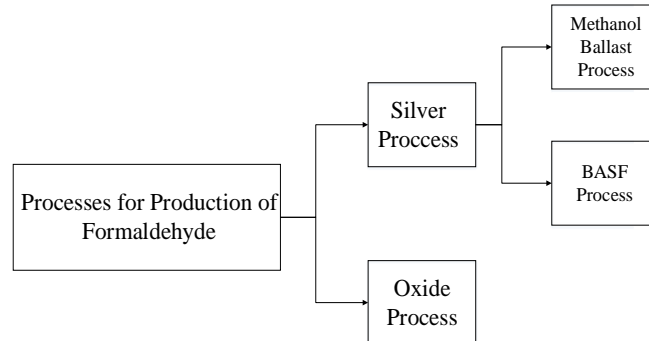
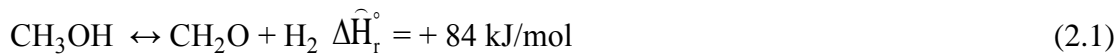

Figure 2.1. The different process types for production of formaldehyde from methanol.

Table 2.2 shows the grade AA of methanol which is commonly used for production of formaldehyde, seen under 2.2 Methanol. The table shows the content of this methanol grade and what impurities that exist [1]. More information about methanol can be found under 2.2 Methanol.

### 2.4.1 Silver Process

There are two kinds of silver processes the methanol ballast process and the BASF process, which are quite similar, but is described under separate sub headings. As the name indicate both processes are applying a silver gauze or crystals as the catalyst. During the processes the following three reactions, reaction (2.1) – (2.3), occur [1, 2, 8, 10].



Reaction (2.1) is methanol dehydrogenation, reaction (2.2) oxidation of hydrogen to water and reaction (2.3) shows direct oxidative dehydrogenation. The exothermic reaction, reaction (2.3), convert between 50 – 60 % of the methanol to formaldehyde [1, 2, 10, 12].

Both processes are run at close to atmospheric pressures and under adiabatic conditions. It is also important that the methanol-air mixture is composed so that it lies outside the explosive limit, which means a methanol concentrations of about 36 – 40 wt% [1, 2, 7, 8, 10, 19, 22]. In Figure 2.2 the most important parts of the silver processes can be seen.

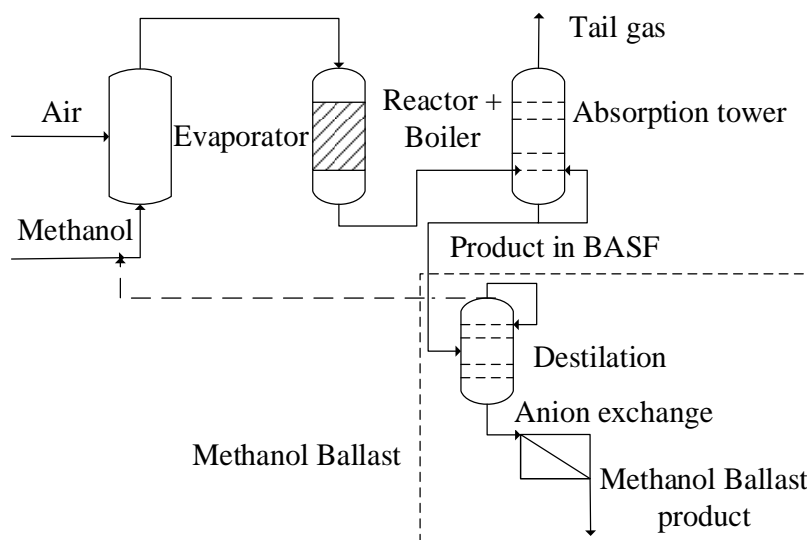

Figure 2.2. A schematic overview of the silver process. The dashed square shows what only exist in the methanol ballast process.

#### 2.4.1.1 Methanol Ballast Process

The methanol ballast processes is run at a temperature of around 600 °C. Compared to the BASF process the methanol ballast process runs at lower temperature, which have the effect that the reactions are not completed and some of the methanol is therefore recycled back to the inlet, as can be seen in Figure 2.2. This is one of the ways the temperature is kept under control [19]. Because the reactions are incomplete the product is usually distilled to reach a higher concentration, se Figure 2.2. Without distillation the product would reach about 42 wt% formaldehyde, after distillation the product can contain 55 wt% with around 1 wt% of methanol [1, 2, 8, 10]. The conversation of methanol in the ballast process lays about 77 – 88 % and the yields for the processes are between 91 – 92 % [1].

#### 2.4.1.2 BASF Process

The production temperature for the BASF process is around 700 °C, the BASF process have full conversion compared to the methanol ballast process. The product contains between 40 to 55 wt% of formaldehyde, with less than 1.3 wt% of methanol [1, 2, 8, 10]. The methanol conversion for the BASF process lies between 97 and 98 % with a yield of 89.5 – 90.5 % [1]. The main by-products for both processes are MF and formic acid that are removed by anion exchange [1, 2, 8, 10].

#### 2.4.2 Oxide Process

The oxide process was first used by Formox. The process is run at atmospheric pressure and temperatures between 300 – 400 °C, with proper temperature controls [1, 2, 5, 8, 10]. At that temperature interval only direct oxidative dehydrogenation, reaction (2.3) in the previous section, occurs [1, 2]. If temperatures exceed 470 °C reaction number (2.4) will start [1, 7, 8];

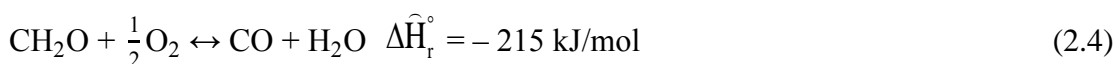

In Figure 2.3 a simplified scheme of the oxidation process can be seen. This process uses a methanol-air feed that are below the lower level of the flame and explosion mixture of 6%. To be able to have higher methanol concentration, the tail gas is recycled and mixed together with the ingoing stream of air to reduce the oxygen content to 10 mol%, as can be seen in Figure 2.3. [1, 2, 10, 22]. The catalyst used for the oxide process is usually iron-molybdenum, but vanadium oxide could be applied as well. The catalyst is loaded in a multitubular fixed-bed reactor, with the temperature controlled by having a medium, a kind of oil, on the outside of the tube. Conversions for this process can be as great as 99 % and the yield as great as 92.5 % [1, 2, 5, 7, 8, 10, 19, 23]. Water is added in the top of the absorption tower, see Figure 2.3. This is important because the water regulates the formaldehyde concentration [1, 8]. The most common by-products are CO and DME. CO<sub>2</sub> and formic acid are might also be produced but in smaller amounts. The by-products are separated from the product, the same way as in the methanol ballast process, by the absorption tower or anion exchanger [2, 8, 10]. The product produced consist of somewhere in-between 0.5 to 1.5 wt% of methanol and up to 55 wt% of formaldehyde and there is therefore no need for distillation of the product [1, 2, 5, 8].

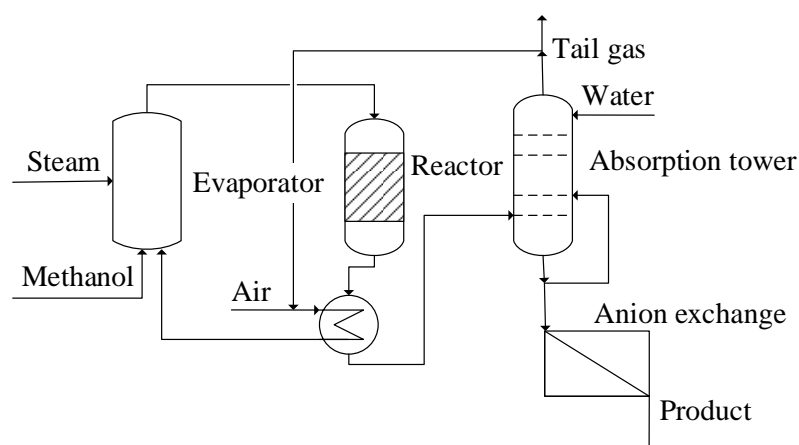

Figure 2.3. A schematic scheme over the oxidation process.

#### 2.4.2.1 Which to Choose?

The choice of process is decided by economic aspects (were local effects can have a large impact), use of product, size of the plant as well as operation of the plant [1, 2, 6, 7]. Operating cost as well as the investment cost for the oxide process is greater than for the silver process according to Ullman's Encyclopedia of industrial chemistry (2012) as well as by Encyclopedia of Catalysis (2002) while Soares et al. (2013) argues the exact opposite. When it comes to flexibility of the process they also reason differently, Soares et al. (2013) argue that the silver process is more flexible and easier operate, while Ullman's Encyclopedia of industrial chemistry (2012) says the direct opposite [1, 7, 10]. The oxide catalyst has a longer life, nearly twice as long compared to the silver catalyst [2, 7], however longer down time is needed to change the catalyst in the oxide plants compared to the silver plant [1, 2].

With increasing methanol prices, the oxide process becomes favored as they require lower methanol flows [9, 14]. The oxide process also has to think about how to let out their tail gas, which mostly consist of nitrogen, oxygen and CO, but also DME and other compounds from the absorption tower such as formaldehyde and methanol exist in the tail gas. Because of these compounds the tail gas cannot be released into the air as it is, compared to the silver processes that can let their tail gas go without consideration. The silver processes tail gas is usually sent to a burner to generate steam since it consist of about 20 mol% hydrogen [1, 10]. A summary of the three processes conversion, yield, weight percentage of formaldehyde and methanol in the product can be seen in Table 2.3 [1, 2, 6, 7]. The choice of process comes down to, as said in the beginning of this paragraph, economic aspects, use of product, the size of plant and the operation of the plant.

*Table 2.3 Three formaldehyde production processes, methanol ballast, BASF and the oxide process, and a summary of production such as conversion and yield in percent and the amount of formaldehyde and methanol that exist in product stream in weight percent [1].*

	<b>Methanol Ballast</b>	<b>BASF</b>	<b>Oxide</b>
<b>Conversion [%]</b>	77 – 88	97 – 98	99
<b>Yield [%]</b>	86 – 90	89.5 – 90.5	< 92.5
<b>Formaldehyde [wt%]</b>	42	40 – 55	< 55
<b>Methanol in product [wt%]</b>	< 1	< 1.3	0.5 – 1.5

## 2.5 Catalysts

### 2.5.1 Silver Catalyst

As mentioned in the previous section, there are two main process used today which uses different catalysts. The silver processes uses (as the name implies) a silver catalyst that is unsupported. The reactor is filled with a shallow bed of silver crystals that are 10 – 50 mm thick or fine silver gauze on trays. Metallic catalyst are not commonly used for catalytic reaction, but if the reaction is strongly exothermic, as the dehydrogenation of methanol, they can be used. The catalyst is very sensitive to metals or sulfur, which causes the catalyst to deactivate. This results in that all pipes that are in contact with the silver catalyst need to be made of alloys, for example in Kirk-Othmer Encyclopedia of Chemical Technology (2013) they talk about a 316 stain less steel. The deactivation time of the catalyst is usually around 3 – 5 months [1, 2, 7, 10, 24].

### 2.5.2 Iron-Molybdate Catalyst

The iron-molybdenum catalyst was discovered in 1926. In 1931, Adkins and Peterson wrote an article where they had looked on iron, molybdenum and iron-molybdenum. The conclusions of this study were that, when using molybdenum as a catalyst an excess of methanol was needed, while using iron as a catalyst formaldehyde would not desorb and continued reacting to carbon oxides. The mix between the two in equal amounts, however, gave good results and this is the most common catalyst used today [25]. The atomic ratio between the Mo:Fe has become higher, being 1.5 – 2.0. The high composition of molybdate is necessary to get high selectivity [1, 8, 10]. In industrial contexts an atomic ratio of as high as 3 is applied [7, 10, 11]. One reason why high composition of molybdate is needed is

because volatile methoxy species will become produced during the process and react with  $\text{MoO}_3$  on the surface through interactions with methanol. That will lead to the formation of whiskers or needle-like  $\text{MoO}_3$  crystals as a result of temperature and/or the pressure from the methanol. Another reason why a high amount of molybdate is needed, is because the selectivity will otherwise decrease. The  $\text{MoO}_3$  will lead to that a pressure is built up which will in the end lead to that the plant will have to shut down and replace the catalyst<sup>1</sup>. This catalyst has a lifetime of 1 – 2 years [5, 10, 13, 21-23]. Small amounts of the promoters  $\text{V}_2\text{O}_5$ ,  $\text{Cr}_2\text{O}_3$ ,  $\text{CuO}$ ,  $\text{CoO}$ , and  $\text{P}_2\text{O}_5$  could be present on the catalyst [1, 7, 10]. Not a lot of research has been done on the effects of promoters. A report written by Sánchez et al. (1988) says that when adding chromium (III) they could see an increase in the specific surface at a lower Mo:Fe atomic ratio. They even obtained a higher yield with the promoted catalyst than when using an industrial one [26].

### 2.5.3 Vanadium-Oxide Catalyst

Vanadium-oxide catalyst could be used as an alternative to the iron-molybdate catalyst when operating an oxidation [2, 7, 9, 13, 21, 24]. This is, however, not the catalyst used commercially, but there have been research done on this catalyst. For example, the volatility of vanadium has been looked at, for instance in a paper that was written by Häggblad et al. (2009) where they come to the conclusion that vanadium is more volatile than molybdate when deactivating [13]. Massa et al. (2011) studied a spinel-type catalyst that consisted of iron, molybdate, vanadium and oxides. The conclusion in that article was that this system was less volatile than the iron-molybdate and the vanadium-oxide catalyst, but this catalyst is not as selective as the iron-molybdate catalyst [9].

## 2.6 Kinetics

The mechanism for the oxidation process over an Mo:Fe catalyst is of redox characteristics, [1, 7]. There are two kinds of redox kinetic mechanisms that are presented for oxidation of methanol, Mars-van Krevelen (MvK) and Langmuir-Hinshelwood (LH) [5, 7, 27]. According to the review written by Soares et al. (2005) most consider the MvK to be the best explanation [7]. [7]. Deshmukh et al. (2005) states in their report that at low partial pressure of methanol, the MvK model can be assumed but at higher methanol pressures LH is a more suitable fit [5].

In equation (2.3) the direct oxidative dehydrogenation, found under 2.4.1 Silver Process, it can be seen that the products are formaldehyde and water. Higher conversions of methanol result in more produced water therefore the effect of water needs to be taken in to consideration. Especially important for the oxidation process that has a methanol conversion of about 99 %. Kinetic studies have come to the conclusion that the produced water competes for the same active sites as the methanol. The water also prohibits formaldehyde from readsorbing and continues to oxidize to other compounds because water is more strongly adsorbed to the catalysts. The readsorbing of the products result in a decrease of the reaction

---

<sup>1</sup> Mads Kaarsholm, Haldor Topsøe A/S, 28<sup>th</sup> of May 2015

rate [1, 5, 12, 27-29]. To describe the general kinetic rate expression, a power law is used, see equation (2.5) [1]. From experiments, a lot of different rate expressions have been developed in order to describe the phenomenon that have been seen during that experiment. In the literature, these rates vary depending whether they are considered to be of a MvK type or a LH type [5].

$$r = kP_{\text{CH}_3\text{OH}}^x P_{\text{O}_2}^y P_{\text{H}_2\text{O}}^z \quad (2.5)$$

### 2.6.1 Langmuir-Hinshelwood

Figure 2.4 illustrates the LH mechanism, which is a kinetic module that explains the reaction that occurs on a catalytic surface, for a gas and a porous solid. What happens is that the reacting substances attaches to the surface, at different places (A). The particles then diffuses towards one another at the surface (B), when the particles are close enough, a reaction occur and the new molecules are formed (C). The new molecule desorb from the surface of the catalyst (D), and the mechanism is completed [30].

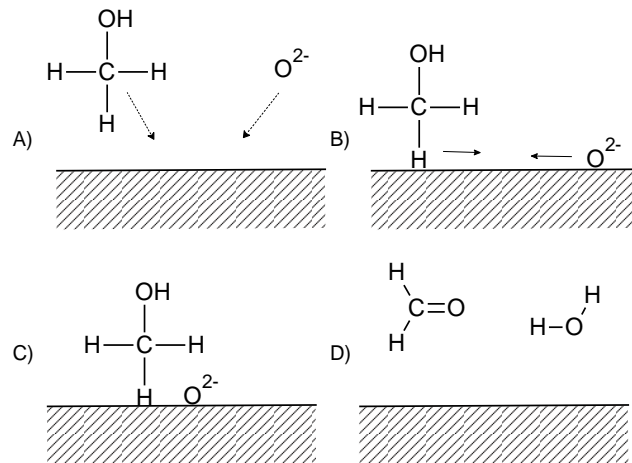

Figure 2.4. The LH mechanism is here explained by 4 sub pictures. A) The two molecules attached to the surface. B) The molecules diffuse towards one another. C) The molecules are react. D) The new molecules desorb.

### 2.6.2 Mars-van Krevelen

Lafyatis et al. (1994) explains from a MvK point of view how the reaction mechanism can look, the mechanism can be seen in Figure 2.5. First the methanol's hydroxyl group will be removed of its hydrogen so that it can attach to the catalytic surface on an oxygen vacant place (A). The molecule then loses a second hydrogen to a nearby oxygen site which leads to formation of formaldehyde which can desorb from the surface (B and C). Two separate hydroxyl groups have now been produced and can react with one another (or from another methanol oxidations) and become water (D). According to Lafyatis et al. (1994) the rate limiting step is when the second hydrogen is to be detached from the methoxide ion ( $\text{CH}_3\text{O}^-$ ), while a report written by Pernicone (1968) et al. argues that it is when formaldehyde is desorbing [12, 27, 29].

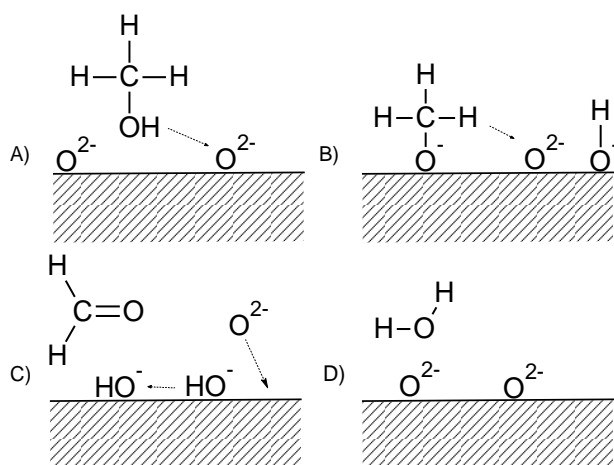

Figure 2.5. The MvK mechanism described by four pictures. A) The methanol loses its hydrogen from its hydroxyl group to an oxygen atom (that is attached to the surface of the catalyst in a vacant place) B) The oxygen atom has attached the molecule to the surface and a second hydrogen is detached to an oxygen atom. C) The formaldehyde molecule de-adsorb from the catalytic surface by making a double bond to the oxygen atom. A hydroxyl group reacts with a hydrogen from another hydroxyl group. D) Water is formed and detaches from the catalytic surface and a new oxygen atom attaches in the lattice.

## 2.7 Overview of Laboratory Experiments

A lot of experiments on methanol to formaldehyde have been performed. The experiments have been done for different purposes, such as looking at different catalysts, deactivation and reduction of the surface of the Mo:Fe catalyst, preparation of catalysts and the kinetics. Most of the experiments have used oxygen instead of air with either helium or nitrogen as their inert gas. How methanol has been added has been solved in some different ways. One way is by letting methanol drop down into the gas stream, Deshmukh et al. (2005) had a methanol bath where the gases bubbled up the methanol.

The reactor used is usually made of stainless steel, the exception being experiments that are done for kinetic purposes that use other types of reactors usually of glass [5, 6, 8, 9, 11, 12, 21-23, 26, 28, 29, 31, 32]. The amount of catalyst used ranges from 0.1 gram up to just above 1 gram [5, 6, 32]. Temperatures ranged from 200 – 350 °C for most of the experiments were Whiting et al. (2014) had temperature ranges from 25 °C up to 500 °C. The majority of the experiments were run at close to atmospheric pressures, while Hassan and Mitchell (2010) had their experiment done at 10 atm [5, 6, 9, 11, 21-23, 26, 31]. From a report written by Häggblad et al. (2008) it can be seen that from a commercial catalyst, Mo:Fe catalyst, the largest by-products are DME and carbon oxides (CO<sub>x</sub>), both produced in low content [22].



### **3 Method**

The first part of this master's thesis was done as a literature study which is presented in 2 Theoretical Background. This chapter includes information on for example how the experiments could be done by comparing different laboratory experiments. The information needed was gathered from encyclopedias, books and articles.

The second and larger part of this master's thesis is to produce formaldehyde from methanol with different purities. The experimental part is described in detail in 4 Experimental Part. The experiments have been planned together with the supervisors for this project and with the help of HT and different research articles. Before entering the laboratory a risk assessment needed to be done and approved by head of department, the safety officer and the supervisors for the project. The products were analyzed with a mass spectrometer (MS) and Microsoft Excel was used for handling the data.

## 4 Experimental Part

### 4.1 Experimental setup

The experimental set-up that was used can be seen in Figure 4.1. A stainless steel tubular reactor was used with 3.5 catalyst pellets per tube diameter, with a catalyst diameter at 4.5 mm and an in diameter of the reactor at 16 mm. The catalyst bed was made up of five milliliters catalyst. The rest of the reactor was filled with alpha-alumina with glass wool in both the inlet and outlet of the reactor as well as in-between the catalyst and the alpha-alumina. The temperature for the experiments was set to 280 °C with no added pressure. As can be seen in Figure 4.1 the inlet gas streams were connected to a mass flow controller (MFC) that was calibrated and controlled by a regulator box. The impurities were added to the methanol which was then put in to a syringe, the syringe was placed in a syringe pump that slowly added the right amount to the process.

The gases (air, nitrogen, and argon) were sent through a preheater, seen as preheater 2 in Figure 4.1. Between preheater 2 and the reactor, the methanol vapor was added. The methanol became vaporized by a separate preheater to remove the chance of drop formation occurring, seen in Figure 4.1 as preheater 1. After the reactor a postheater was added to keep temperatures at about 150 °C to make sure that no polymerization from the produced formaldehyde starts to occur in the pipes. The reactor and preheater were controlled by thermocouples. After the reactor most of the stream continues through a pipe with a postheater to the fume hood. The rest of the products were sent directly to a MS for analyzing, were the emissions from the MS were led to the fume hood as well. An internal standard were added in the form of 1% argon.

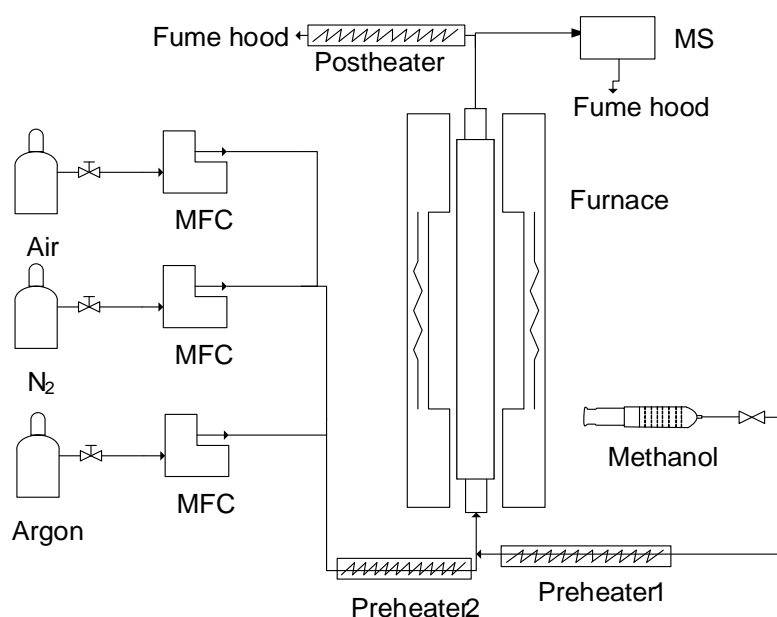

Figure 4.1. A schematic picture of the experimental set up that were used.

Typical impurities that exist in the crude methanol, normally, can be seen in Table 4.1 (data supplied by HT). The last two in the table, methyl violet and denatonium benzoate, only needs to be added in some parts of the world and will therefore be excluded from this project. For the experiments on higher alcohols, 1-butanol and 2-propanol were used. The Methyl ethyl ketone was not looked at due to the low concentrations. The impurities were looked at one-by-one, to be able to see the exact effect of that particular compound and last, a mixture of all impurities was done. In the mixture the higher alcohols were simulated by 1,500 ppm 1-butanol and 1,500 ppm 2-propanol.

*Table 4.1. The impurities that exist in crude methanol with the quantities in ppm. The last two, Methyl violet and Denatonium Benzoate is only added in some parts of the world.*

<b>Impurity</b>	<b>Crude Methanol [ppm]</b>
<b>Ethanol</b>	600 – 2,000
<b>Acetone</b>	20 – 100
<b>Methyl ethyl ketone</b>	5 – 40
<b>MF</b>	500 – 700
<b>Higher alcohols</b>	1,000 – 3,000
<b>Methyl violet</b>	< 1
<b>Denatonium benzoate</b>	< 5

## 4.2 Flows

The flows used were based on the gas hourly space velocity (GHSV) that was given by HT. From assuming a catalytic volume to be 5 ml (the total reactor being 25 ml), from equation (4.1) the total volume flow could be calculated, seen in equation (4.2). All calculations were done in Microsoft Excel.

$$\text{GHSV} = \frac{Q}{V} \quad (4.1)$$

$$Q = \text{GHSV} \cdot V = 6,000 \cdot 5 = 30,000 \text{ ml/h} = 500 \text{ ml/min} \quad (4.2)$$

The compositions that existed in the inlet gas stream were known; from this the gas flow for every component could be calculated listed in Table 4.2. The impurities were added directly to the methanol stream and doses therefore not affect the flow or composition.

*Table 4.2. The flow in ml/min is for the different compounds used for the experiments as well as the composition in mol%.*

<b>Materials</b>	<b>Gas Flow [ml/min]</b>	<b>Composition [mol%]</b>
<b>Methanol + Impurities</b>	40	8
<b>Air</b>	238.10	48
<b>Nitrogen</b>	212.40	42
<b>Argon</b>	5	1

The methanol flow started in its liquid phase, which then becomes vaporized. In Table 4.2 the methanol flow is for the gas and is therefore needed to be converted to liquid flow. The calculations, are shown in equation (4.3), 22.4 comes from calculations with the help of the ideal gas law.

$$\text{liquid flow} = \frac{\text{gas flow}}{22.4 \cdot 1,000} \cdot M = 0.0572 \text{ g/min} = 3.43 \text{ g/h} \quad (4.3)$$

### 4.3 MS Analysis

As mentioned earlier, the production stream were analyzed with the help of a MS. Table 4.3 list the masses seen in the MS for the materials that were looked at. Overlaps do occur, as for example in the case of methanol and MF on the mass of 31. This overlap is taken in to consideration by removing the peak that we see at 60 from the 31 peak. In some cases the percentage of the peaks comes in to considerations which can be seen when looking at the general MS spectrum for the different compounds. How the different overlaps have been calculated can be seen in Appendix A.

*Table 4.3. The elements the report have looked at are listed in the table with the masses that they can be seen for in the MS. The third column show what mass that have been used to see the different compounds. No mass below 10% of the intensity for any element is shown.*

<b>Compounds</b>	<b>Masses seen in the MS</b>	<b>Mass used</b>
<b>Methanol</b>	31,32,29,15	31
<b>Formaldehyde</b>	29,30,28	29
<b>DME</b>	45,46,29,15	45
<b>MF</b>	31,32,29,60,15	60
<b>Dimetoxy methane</b>	45,75,15,29,31	75
<b>CO<sub>2</sub></b>	44,28,16,12	44
<b>CO</b>	28,12	12
<b>Water</b>	18,17,16,15	18
<b>N<sub>2</sub></b>	28,14	28
<b>O<sub>2</sub></b>	32,16	16
<b>Argon</b>	40,20	40
<b>Formic acid</b>	29,46,45,28,17	46
<b>Ethanol</b>	31,45,29,27,46	27
<b>1-Butanol</b>	56,31,41,43,27,42,29,355,39,28	56
<b>2-Propanol</b>	45,43,27,29,19,5	27
<b>Acetone</b>	43,58	43

## 5 Result and Discussion

In all cases the results are the average of two experiments. Tables containing the values of the different figures can be seen in Appendix B. The section start off with the experimental result for pure methanol, then the results for different impurities are seen ending with a discussion on how this project is seen from an social and ethical point of view.

### 5.1 Blank experiment

Before starting the experiment the gases and methanol was run through the reactor. This to see that the element balance, see Appendix C, was correct and to see if there was anything ells that needed to be corrected. For example is could be seen that the relation for methanol tops at 31 and 29 are not 50 % but 60 %. A top at 18 (water) could also be detected even though this should not be seen. How the methanol varies over time can be seen in Figure 5.1, were it can be seen that there might be some problem with the vaporization of methanol. This might also be due to that the gases flows and sometimes draws more methanol in to the reactor. The elemental balances, se Appendix C, did not add up, this means there was something wrong in the system, but what it was could not be found or solved.

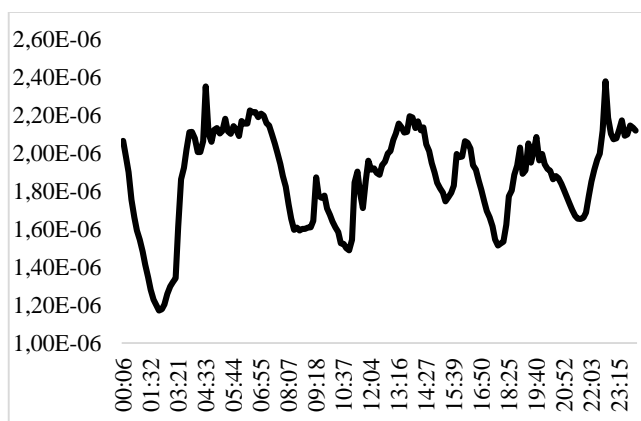

*Figure 5.1 Methanol flow over time.*

Figure 5.2 shows the experiment with the empty reactor (black) and were alpha-alumina had been added (gray). The experiment with alpha-alumina was done to make sure that alpha-alumina did not have any affects. An amount of less than 0.40 % of DME could be seen.

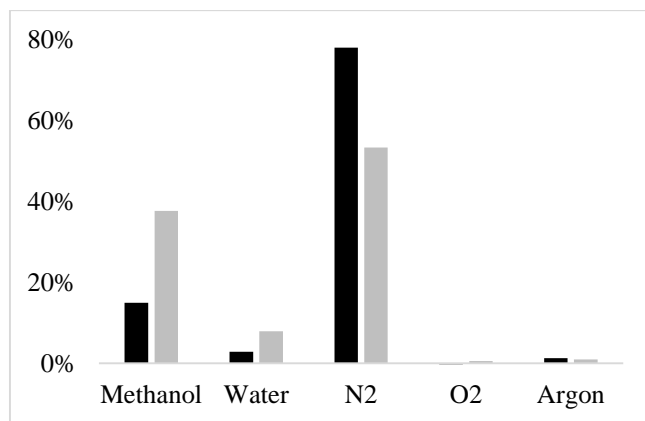

Figure 5.2 Experimental values for the empty reactor (black) and when alpha-alumina was added to the reactor (gray).

A high amount of methanol could be seen in Figure 5.2 especially for when alpha-alumina was added (gray), one reason for this might be because the methanol peak shows condensation, and this would also apply for water. If there is condensation, this will give more area in the detector because the liquid could be seen as a kind of blockage that makes it harder for the gases to enter the MS. This will affect the way the MS scales the different substances, because MS scales the results to the one that is the highest and condensation could disturb this. The values that are down to ppm levels should also be considered a second time because at those values the MS might not be as accurate because of noise. It might also be that more methanol is actually entering the system, because the gases might pull more methanol into the system. This is very hard to check as well because the calibration of the syringe pump is done to atmospheric pressure.

## 5.2 Pure Methanol

Shown in Figure 5.3 the result from the experiment done on pure methanol. The reason for the high amount of methanol might be because of lack of a hot spot. The lack of hot spot means that the temperature profile might not be good enough. As said in the previous section, it might also be condensation occurring in the MS or that higher quantities of methanol actually enters the system.

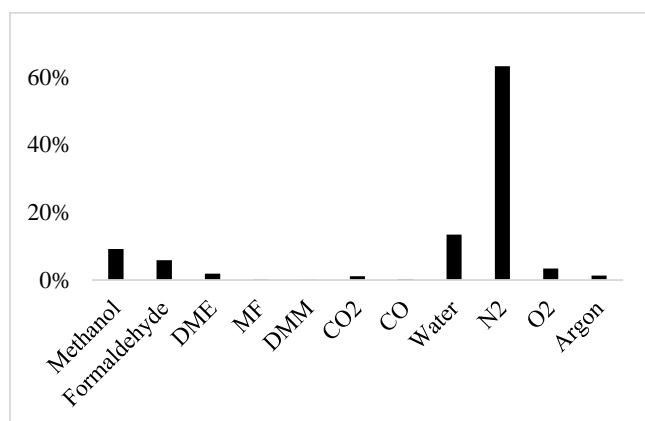

Figure 5.3. The results from the experiments conducted in this study with pure methanol.

Figure 5.4 shows how the different components are produced at different temperature. It can be seen that methanol decreases with the temperature and carbon monoxide increases. At higher temperature full combustion seems to occur in greater amount. Because HT runs at 280 °C this is the temperature that this report will continue looking at.

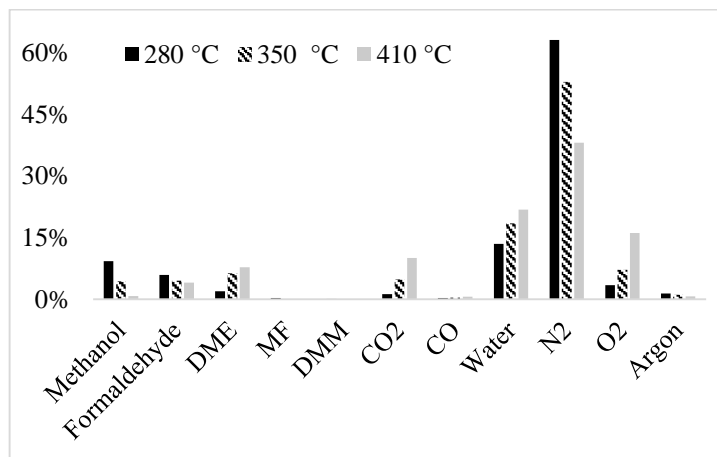

Figure 5.4 A experiment that were run at three different temperatures 280 °C (black), 350 °C (striped) and 410 °C gray.

Because of the great variation in composition of the out-going stream compared to what was expected and the fact that this project aims to study by-products, the components that do not classify as such are not studied further. The by-products are put in a figure alone as can be seen in Figure 5.5 and will be used as the reference for the impure results.

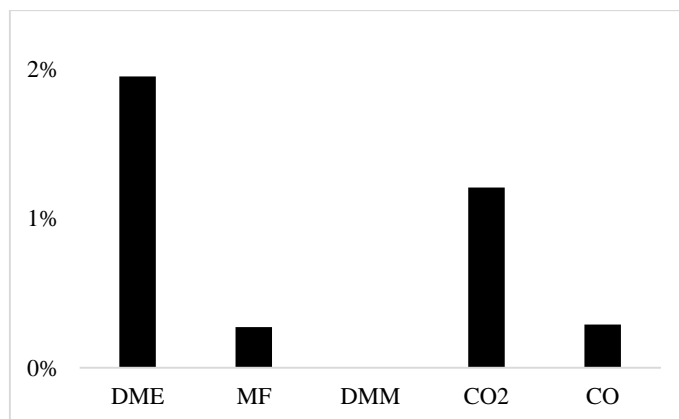

Figure 5.5. The by-products received when using pure methanol.

### 5.3 Ethanol

In Figure 5.6 the by-products that came out from the experiment where 2,000 ppm of ethanol had been added to the methanol can be seen (black). Figure 5.6 also shows the experimental data from the pure methanol case (gray). An increase could be seen in close to all by-products except for the CO<sub>2</sub> case where a decrease was detected. The report also looked into if any diethyl ether, acetaldehyde or formic acid had been produced as by-products but this report could not detect that this was the case and therefore not presented in Figure 5.6.

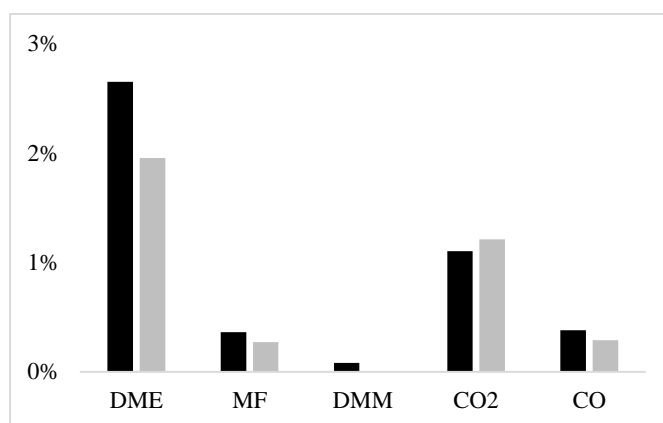

Figure 5.6 Comparison between the experimental data obtained from the pure methanol experiments (grey) and the experiment where 2,000 ppm ethanol was added (black).

### 5.4 Higher Alcohols

Figure 5.7 shows the comparison between the experimental data obtained from the pure methanol experiment (grey) and where 3,000 ppm of a higher alcohol (black) was added. Figure 5.7A shows the addition of 1-butanol as the higher alcohol and Figure 5.7B 2-propanol. An evident increase in DME can also be seen for both plots in Figure 5.7, as well as a small increase in CO. For 1-butanol (A) an increase of DMM can be seen, in both cases a decrease in CO<sub>2</sub> occurs.

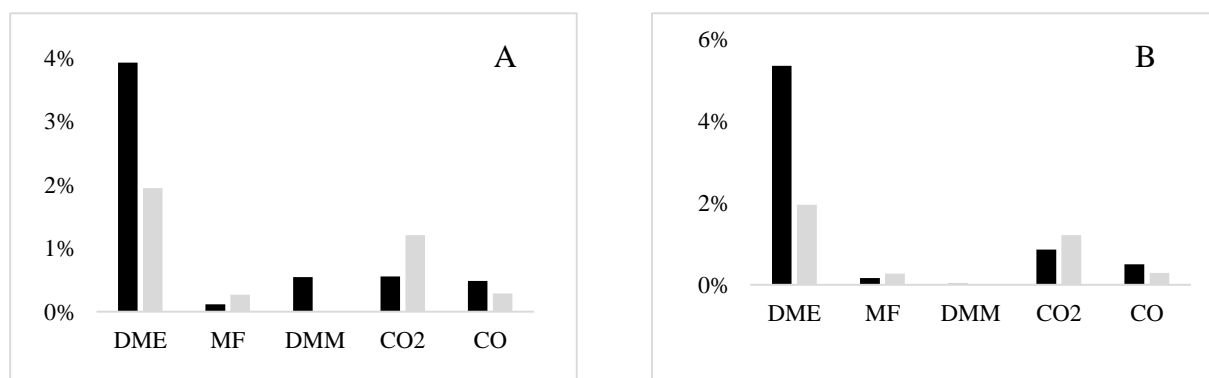

Figure 5.7 Comparison between the experimental data obtained from pure methanol (grey) and methanol containing 3,000 ppm of a higher alcohol (black), in A) 1-Butanol B) 2-Propanol.



## 5.5 Methyl Formate

Presented in Figure 5.8 are the by-products that were produced in the case where 700 ppm MF was added. As with the previous impurities an increase in DME and a decrease in carbon dioxide can be noticed. A small increase in carbon monoxide and DMM is also notable. A small decrease of MF seems to have occur, which is weird because an extra 700 ppm was added. The reason might be because it is so low values that the noise becomes very clear.

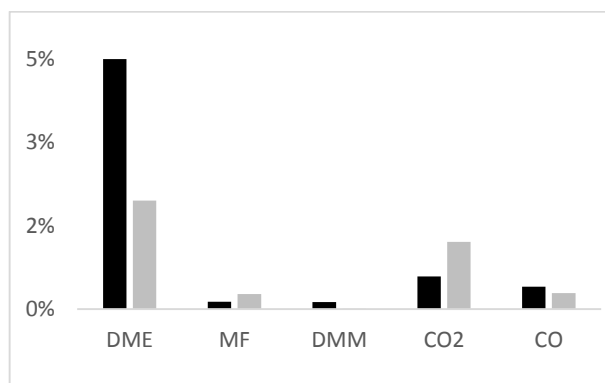

Figure 5.8 Comparison between the experimental data obtained from the pure methanol experiments (grey) and the experiment were 700 ppm MF was added (black).

## 5.6 Acetone

Figure 5.9 shows the experiment were 100 ppm acetone were added to pure methanol. A large decrease can be seen for the carbon dioxide and a vast increase for DME and DMM is also visible. Smaller changes can be seen for MF and carbon monoxide were the first decreases and the second increases.

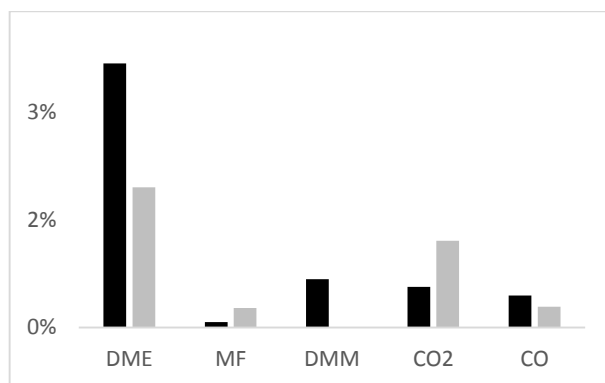

Figure 5.9 Comparison between the experimental data obtained from the pure methanol experiments (grey) and the experiment were 100 ppm of acetone was added (black).

## 5.7 Crude Methanol

Figure 5.10 shows the experiment done with a mixture of all impurities above, see Table 5.1 for a summary of the impurities and the quantities used. For higher alcohols half was 1-butanol (1,500ppm) and the other half was 2-propanol. As in the previous experiments the highest increase in peaks are for DME and DMM, a smaller increase could be seen for carbon monoxide. None of these three by-products should disturb the production of formaldehyde, two of them already exist as by-products today (DME and CO). The third DMM would most probably just react back to methanol and formaldehyde, as aqueous formaldehyde is acidic, with pH below 4, which forces the reaction back to methanol and formaldehyde. Hence DMM will not be a problem because of the low pH that exist in the adsorption tower.

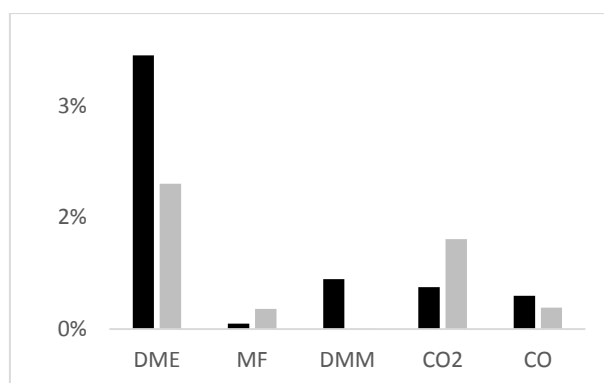

Figure 5.10 Comparison between the experimental data obtained from the pure methanol experiments (grey) and the experiment where all of the impurities were mixed to simulate crude methanol (black).

Table 5.1. The impurities used for the mixture can be seen as well as the quantities used.

<b>Impurity</b>	<b>Crude Methanol [ppm]</b>
<b>Ethanol</b>	2,000
<b>1-Butanol</b>	1,500
<b>2-Propanol</b>	1,500
<b>MF</b>	700
<b>Acetone</b>	100

Figure 5.11 shows one cycle round on the MS. What can be seen is that no other by-products than the once looked at seem to be produced, not in any concentrations that can be seen at least. Figure 5.12 shows an in zoomed version of Figure 5.11 where only the masses of 80 and above are seen, to be sure that no other by-products were produced that could not be seen in the large picture. The small peaks represents noise, this could be seen when looking at the values for the peaks for all the cycles, because close to all other cycles show a response that are smaller than the peak that are seen here.

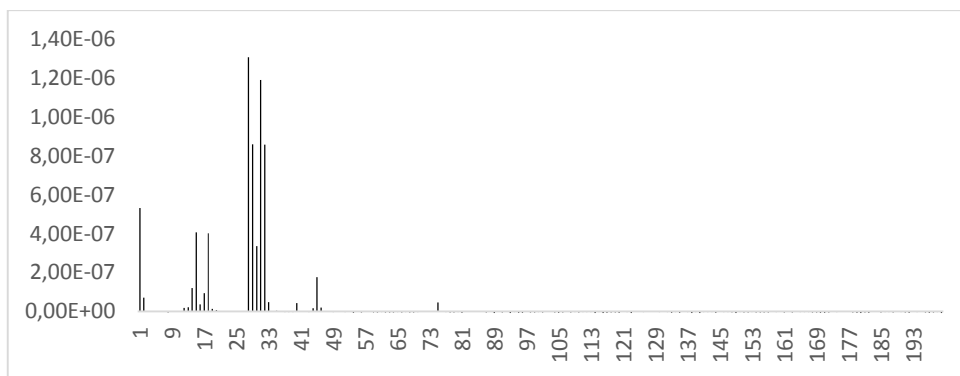

Figure 5.11 A cycle scan in the MS. Were it can be seen that nothing else than what have been reported can be seen.

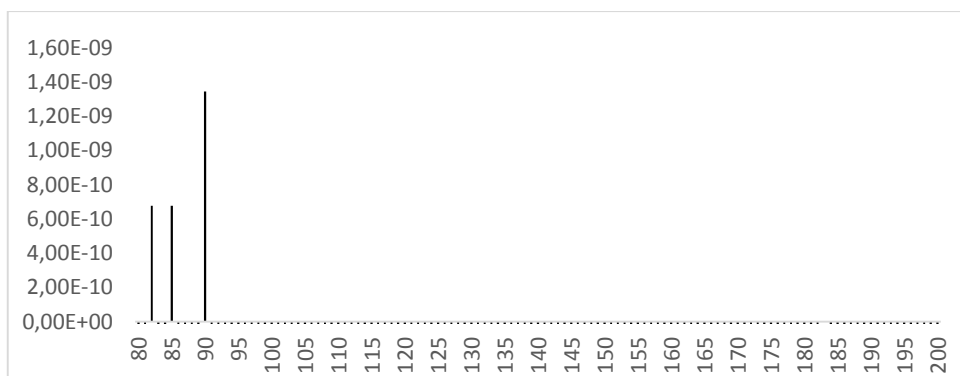

Figure 5.12 An in zoomed cycle scan from the MS with only the masses for 80 and above is seen.

## 5.8 Catalyst

The catalyst was photographed before and after as well as weighed to see if any change could be seen. Figure 5.13 shows on the left how the catalyst looked before a test on the right how a used catalyst looked. The catalyst did not changed significant in mass, the unused catalyst weighed 4,094 g and after the same catalyst weighed 4,085 g. This means that the same amount of weight of coal that have been produced on the catalyst (the reason it is black) have left in the form of, probably, molybdate as this is what leaves the catalyst in deactivation se 2.5.2 Iron-Molybdate Catalyst.



Figure 5.13. On the left an unused catalyst can be seen and on the right a used catalyst.

## **5.9 Social & Ethical Aspects**

This project affects the social and ethical aspects in the way that it looks in to optimization. In case of an optimization it is possible great amount of energy could be saved, if crude methanol can be used instead of a more purified methanol. From an economic stand point it would be beneficial as well, if crude methanol were used, the formaldehyde process would be cheaper to run because methanol stand for large part of the costs for the production of formaldehyde [14].

## 6 Conclusion

The results shows that all the impurities increase the production of DME, most impurities showed a clear increase for DMM as well. Only a small increase for MF, from ethanol as the impurities could be seen. Compared to CO<sub>2</sub> that showed a decrease for all impurities. The reason that a smaller amount of carbon dioxide seems to be formed is probably because other substances are blocking the surface area of the catalyst so that full combustion does not occur. The mixture that contained all impurities showed the same general trend that has been noticed with the other impurities. This means that no interaction between the impurities occurred.

The DME and DMM that was the highest amount of by-products produced should not be any problem for HT to work with. DME already exist in the process today, the only difference is that there will probably become a higher amount of DME if crude methanol is used.

Both by-products are equilibrium equations and will therefore reach a maximum and stay there. DME will be removed from the product in the absorption tower while the DMM will continue with the products. DMM might not even be formed in the HT plant, because when DMM is in an aqueous acid it will be hydrolyzed back to methanol and formaldehyde because of the acidic environment that formaldehyde creates.

Even though a lot of methanol could be seen in most of the experiments very little or close to no oxygen could be seen in the outlet stream. So the high peak that can be seen for methanol should not be due to low conversion, but rather something to do with the MS.

## 7 Future Work

This report have covered all of the impurities as well as mixed them together to see the effects. In continuing this project one needs to do more through calibrations on a MS, if this is to be used but a GC is to be preferred. Because there are a lot of mass overlaps on the MS that are hard to take in to consideration, which is why a GC is strongly suggested to be used. In a GC or highly calibrated MS a crude methanol mix should be tested.

It is needed to continuing this project to see how the conversation and yield affects the increase in by-products. After that crude methanol from a plant should be tried in case the impurities vary. If this is seems to work it could be tried at a higher scale. It is also important to see how the impurities might affect the quality of the formaldehyde in the production.

If the project is continued it will be beneficial to look at what methanol that actually comes out of the reactor. This could be done by letting methanol and nitrogen flow through the reactor and then letting the outlet gases condensate in an ice bath for example. To see if any extra methanol is drawn in to the reactor. Or switch to another set up that are more reliable on how much methanol that actually goes through to the reactor.

## 8 References

- [1] G. Reuss, W. Disteldorf, A.O. Gamer, A. Hilt, Ullman's Encyclopedia of industrial chemistry, Formaldehyde, 2012, pp. 735.
- [2] H.R. Gerberich, G.C. Seaman, H.-C. Corporation, Kirk-Othmer Encyclopedia of Chemical Technology, Formaldehyde, 2013, pp. 1-12.
- [3] L. Ebersson, Nationalencyklopedin, Formaldehyd  
<http://www.ne.se/uppslagsverk/encyklopedi/lång/formaldehyd>, 2015.
- [4] S.S. Srivastava, K.M. Kumari, Encyclopedia of Analytical Chemistry, Online, Environmental Analysis of Formaldehyde, 2006, pp. 1-34.
- [5] S.A.R.K. Deshmukh, M.v.S. Annaland, J.A.M. Kuipers, Kinetics of the partial oxidation of methanol over a Fe-Mo catalyst, Applied Catalysis A, 289 ( 2005) 240-255.
- [6] G.T. Whiting, J.K. Bartley, N.F. Dummer, G.J. Hutchings, S.H. Taylor, Vanadium promoted molybdenum phosphate catalysts for the vapour phase partial oxidation of methanol to formaldehyde, Applied Catalysis A, 485 (2014) 51-57.
- [7] A.P.V. Soares, M.F. Portela, A. Kiennemann, Methanol Selective Oxidation to Formaldehyde over Iron-Molybdate Catalysts, Catalysis Reviews: Science and Engineering, 47 (2005) 125-174.
- [8] A.M. Bahmanpour, A. Hoadley, A. Tanksale, Critical review and exergy analysis of formaldehyde production processes, Reviews in Chemical Engineering, 6 ( 2014 ) 583-604.
- [9] M. Massa, R. Häggblad, S. Hansen, A. Andersson, Oxidation of methanol to formaldehyde on cation vacant Fe–V–Mo-oxide, Applied Catalysis, 408 ( 2011) 63– 72.
- [10] G. Centi, S. Perathoner, Encyclopedia of Catalysis, Selective Oxidation—IndustrialWiley Online Library, 2002.
- [11] A.P.V. Soares, M.F. Portela, A. Kiennemann, L. Hilaire, J.M.M. Millet, Iron molybdate catalysts for methanol to formaldehyde oxidation: effects of Mo excess on catalytic behaviour, Applied Catalysis A: General, 206 (2001) 221-229.
- [12] J.M. Tatibouët, Methanol oxidation as a catalytic surface probe, Applied Catalysis A, 148 (1997) 213-252.
- [13] R. Häggblad, M. Massa, A. Andersson, Stability and performance of supported Fe–V-oxide catalysts in methanol oxidation, Journal of Catalysis, 266 ( 2009) 218–227.
- [14] Methanex, Our Business, methanex.com, Methanol prices from 2002 to 2015.
- [15] H.T.A.S. (HQ), History, About/History <http://www.topsoe.com/>, 2015.
- [16] O. Deutschmann, H. Knözinger, K. Kochloefl, T. Turek, Ullmann's Encyclopedia of Industrial Chemistry, Heterogeneous Catalysis and Solid Catalysts, 1. Fundamentals, 2011.
- [17] J.F. Walker, Production, Formaldehyde 1964, pp. 4-13.
- [18] J. Ott, V. Gronemann, F. Pontezzen, E. Fiedler, G. Grossmann, D.B. Kresebohm, G. Weiss, C. Witte, Ullman's Encyclopedia of industrial chemistry, Methanol, 2012.
- [19] J.A. Moulijn, M. Makkee, A.v. Diepen, Production of Formaldehyde, Chemical Process Technology 2013, pp. 199-201.

- [20] A. English, J. Rovner, J. Brown, S. Davies, Kirk-Othmer Encyclopedia of Chemical Technology, Methanol, 2005, pp. 299-316.
- [21] N. Burriesci, F. Garbassi, M. Petrera, G. Petrini, N. Pernicone, Solid state reactions in Fe-Mo oxide catalysts for methanol oxidation during aging in industrial plants, Studies in Surface Science and Catalysis, 6 ( 1980) 115-126.
- [22] R. Häggblad, J.B. Wagner, S. Hansen, A. Andersson, Oxidation of methanol to formaldehyde over a series of  $\text{Fe}_{1-x}\text{Al}_x\text{-V}$ -oxide catalysts, Journal of Catalysis, 258 ( 2008) 345–355.
- [23] A. Andersson, M. Hernelind, O. Augustsson, A study of the ageing and deactivation phenomena occurring during operation of an iron molybdate catalyst in formaldehyde production, Catalysis Today, 112 ( 2006) 40-44.
- [24] O. Deutschmann, H.K. Zinger, K. Kochloefl, Ullman's Encyclopedia of industrial chemistry, Heterogeneous Catalysis and Solid Catalysts, 2. Development and Types of Solid Catalysts, 2012.
- [25] H. Adkins, W.R. Peterson, The oxidation of methanol with air over iron, molybdenum and iron-molybdenum oxides, Journal of the American Chemical Society, 53 ( 1931) 1512-1520.
- [26] A.M.E. Sánchez, A.F. Tena, M.C.M. Moreno, Oxidation of methanol to formaldehyde on iron-molybdenum oxide catalysts, with and without chromium as a promoter, Reaction Kinetics and Catalysis Letters 38 (1988) 193-198.
- [27] S.D. Lafyatis, G. Creten, G.F. Froment, TAP reactor study of the partial oxidation of methanol to formaldehyde using an industrial Fe-Cr-Mo oxide catalyst, Applied Catalysis A: General 120 ( 1994) 85-103.
- [28] W.-H. Cheng, Methanol and Formaldehyde Oxidation Study over Molybdenum Oxide, Journal of Catalysis 158 ( 1996) 477–485.
- [29] N. Pernicone, F. Lazzarin, G. Liberti, G. Lanzavecchi, On the Mechanism of  $\text{CH}_3\text{OH}$  Oxidation to  $\text{CH}_2\text{O}$  over  $\text{MoO}_3\text{-Fe}_2(\text{MoO}_4)_3$  Catalyst, Journal of Catalysis, 14 ( 1968).
- [30] U.C.f.C.C.a. Physics, Eley-Rideal and Langmuir Hinshelwood Mechanism, in: A. Wolff (Ed.), UCLA, <http://www.chem.ucl.ac.uk/cosmicdust/er-lh.htm>, 2015.
- [31] K.H. Hassana, P.C.H. Mitchell, Evaluation of different methods to prepare the  $\text{Fe}_2\text{O}_3/\text{MoO}_3$  catalyst used for selective oxidation of methanol to formaldehyde, Studies in Surface Science and Catalysis, Elsevier, 2010.
- [32] M.P. House, A.F. Carley, M. Bowker, Selective oxidation of methanol on iron molybdate catalysts and the effects of surface reduction, Journal of Catalysis, 252 ( 2007) 88-96.



## 9 Abbreviations

Table 9.1 shows the different abbreviations that have been used in this report.

*Table 9.1. This table shows the abbreviations and definitions of words used in the rapport.*

<b>Abbreviation</b>	<b>Definition</b>
DME	Dimethyl ether
DMM	Dimetoxymethane
GHSV	Gas Hourly Space Velocity
HT	Haldor Topsøe
LH	Langmuir–Hinshelwood
MF	Methyl formate
MFC	Mass Flow Controller
MS	Mass Spectrometer
MvK	Mars–van Krevelen







# 10 Appendices

## Appendix A

Equations (A.1) to (A.4) below shows the corrections that have been done for the different MS peaks that overlap with another one.

$$m_{\text{methanol}} = m_{31} - m_{60} \quad (\text{A.1})$$

$$m_{\text{Formaldehyde}} = m_{29} - \frac{m_{43}}{0.5} - m_{31} \cdot 0.45 \quad (\text{A.2})$$

$$m_{\text{CO}_2} = m_{44} - m_{43} \left( \frac{0.8}{0.5} \right) \quad (\text{A.3})$$

$$m_{\text{N}_2} = m_{28} - m_{12} \quad (\text{A.4})$$

## Appendix B

This appendix consist of the tables (Table B.1 –B.8) for the different figures seen under 4. Results and Discussion.

*Table B.1 The result for the empty column as well as the results for when alpha-alumina was added can be seen.*

	Empty	Alpha-alumina		Average Alpha-alumina
		Experiment 1	Experiment 1	
<b>Methanol</b>	14.97%	36.18%	39.05%	37.61%
<b>Water</b>	2.84%	9.41%	6.45%	7.93%
<b>N2</b>	77.97%	53.56%	53.01%	53.28%
<b>O2</b>	-0.23%	0.56%	0.57%	0.56%
<b>Argon</b>	1.30%	0.29%	0.93%	0.93%

*Table B.2 Listed are the compositions for the two experiments done on pure methanol as well as the calculated average value which is the used on in the report.*

Element	Composition [mol%]		
	Experiment 1	Experiment 2	Average
<b>Methanol</b>	8.86%	9.62%	9.24%
<b>Formaldehyde</b>	4.62%	7.20%	5.91%
<b>DME</b>	1.64%	2.27%	1.95%
<b>MF</b>	0.30%	0.00%	0.15%
<b>DMM</b>	0.01%	0.00%	0.01%
<b>CO<sub>2</sub></b>	1.52%	0.90%	1.21%
<b>CO</b>	0.30%	0.28%	0.29%
<b>Water</b>	10.87%	16.09%	13.48%
<b>N<sub>2</sub></b>	70.73%	55.68%	63.20%
<b>O<sub>2</sub></b>	0.21%	6.59%	3.40%
<b>Argon</b>	1.65%	1.09%	1.37%

*Table B.3 Listed are the compositions for the two experiments done on methanol with added ethanol as well as the calculated average value which is the used on in the report.*

	<b>Experiment 1</b>	<b>Experiment 2</b>	<b>Average</b>
<b>Methanol</b>	19.78%	9.80%	14.79%
<b>Formaldehyde</b>	9.06%	4.49%	6.77%
<b>DME</b>	3.67%	1.63%	2.65%
<b>MF</b>	0.25%	0.47%	0.36%
<b>DMM</b>	0.15%	0.01%	0.08%
<b>CO<sub>2</sub></b>	0.77%	1.43%	1.10%
<b>CO</b>	0.45%	0.31%	0.38%
<b>Water</b>	14.43%	10.10%	12.27%
<b>N<sub>2</sub></b>	49.64%	69.44%	59.54%
<b>O<sub>2</sub></b>	0.66%	0.45%	0.55%
<b>Argon</b>	0.94%	1.66%	1.30%
<b>Etanol</b>	0.14%	0.16%	0.15%

*Table B.4 Listed are the compositions for the two experiments done on methanol with added 1-Butanol as well as the calculated average value which is the used on in the report.*

	<b>Experiment 1</b>	<b>Experiment 2</b>	<b>Average</b>
<b>Methanol</b>	23.82%	22.19%	23.00%
<b>Formaldehyde</b>	9.95%	11.45%	10.70%
<b>DME</b>	3.36%	4.51%	3.93%
<b>MF</b>	0.07%	0.17%	0.12%
<b>DMM</b>	0.53%	0.56%	0.55%
<b>CO<sub>2</sub></b>	0.49%	0.62%	0.56%
<b>CO</b>	0.48%	0.49%	0.49%
<b>Water</b>	12.84%	15.25%	14.05%
<b>N<sub>2</sub></b>	46.92%	43.12%	45.02%
<b>O<sub>2</sub></b>	0.66%	0.83%	0.75%
<b>Argon</b>	0.86%	0.77%	0.82%
<b>1-Butanol</b>	0.00%	0.00%	0.00%

*Table B.5 Listed are the compositions for the two experiments done on methanol with added 2-propanol as well as the calculated average value which is the used on in the report.*

	<b>Experiment 1</b>	<b>Experiment 2</b>	<b>Average</b>
<b>Methanol</b>	19.87%	26.51%	23.19%
<b>Formaldehyde</b>	10.37%	8.41%	9.39%
<b>DME</b>	5.23%	5.45%	5.34%
<b>MF</b>	0.12%	0.20%	0.16%
<b>DMM</b>	0.00%	0.10%	0.03%
<b>CO<sub>2</sub></b>	0.69%	1.03%	0.86%
<b>CO</b>	0.46%	0.54%	0.50%
<b>Water</b>	16.45%	14.35%	15.40%
<b>N<sub>2</sub></b>	45.12%	41.22%	43.17%
<b>O<sub>2</sub></b>	0.65%	1.15%	0.90%
<b>Argon</b>	0.82%	0.71%	0.77%
<b>2-Propanol</b>	0.15%	0.18%	0.17%

*Table B.6. Listed are the compositions for the two experiments done on methanol with added Methyl formate (MF) as well as the calculated average value which is the used on in the report.*

	<b>Experiment 1</b>	<b>Experiment 2</b>	<b>Average</b>
<b>Methanol</b>	18.38%	19.24%	18.81%
<b>Formaldehyde</b>	9.47%	9.35%	9.41%
<b>DME</b>	4.83%	4.16%	4.49%
<b>MF</b>	0.09%	0.17%	0.13%
<b>DMM</b>	0.14%	0.12%	0.13%
<b>CO<sub>2</sub></b>	0.53%	0.65%	0.59%
<b>CO</b>	0.40%	0.41%	0.40%
<b>Water</b>	13.48%	15.94%	14.71%
<b>N<sub>2</sub></b>	51.80%	48.44%	50.12%
<b>O<sub>2</sub></b>	0.54%	0.55%	0.54%
<b>Argon</b>	0.29%	0.91%	0.60%



Table B.7 Listed are the compositions for the two experiments done on methanol with added acetone as well as the calculated average value which is the used on in the report.

	<b>Experiment 1</b>	<b>Experiment 2</b>	<b>Average</b>
<b>Methanol</b>	20.08%	25.27%	22.67%
<b>Formaldehyde</b>	10.65%	9.08%	9.87%
<b>DME</b>	4.55%	2.81%	3.68%
<b>MF</b>	0.08%	0.07%	0.08%
<b>DMM</b>	0.39%	0.95%	0.67%
<b>CO<sub>2</sub></b>	0.59%	0.54%	0.57%
<b>CO</b>	0.42%	0.47%	0.45%
<b>Water</b>	13.95%	11.00%	12.47%
<b>N<sub>2</sub></b>	47.77%	48.18%	47.98%
<b>O<sub>2</sub></b>	0.60%	0.71%	0.66%
<b>Argon</b>	0.88%	0.88%	0.88%
<b>Acetone</b>	0.04%	0.03%	0.04%

Table B.8 Listed are the compositions for the two experiments done with “crude” methanol. Methanol with all of the impurities added to one mix. The table also contains calculated average value which is the used on in the report.

	<b>Experiment 1</b>	<b>Experiment 2</b>	<b>Average</b>
<b>Methanol</b>	20.91%	23.81%	22.36%
<b>Formaldehyde</b>	9.81%	9.66%	9.74%
<b>DME</b>	2.98%	3.02%	3.00%
<b>MF</b>	0.08%	0.14%	0.11%
<b>DMM</b>	0.30%	0.39%	0.34%
<b>CO<sub>2</sub></b>	0.56%	0.67%	0.61%
<b>CO</b>	0.45%	0.49%	0.47%
<b>Water</b>	12.73%	12.34%	12.54%
<b>N<sub>2</sub></b>	50.62%	47.87%	49.24%
<b>O<sub>2</sub></b>	0.56%	0.66%	0.61%
<b>Argon</b>	0.94%	0.87%	0.91%
<b>Acetone</b>	0.04%	0.07%	0.06%
<b>Ethanol+2-propanole</b>	0.14%	0.16%	0.15%
<b>Formic acid</b>	0.00%	0.00%	0.00%
<b>1-Butanol</b>	0.00%	0.00%	0.00%

## Appendix C

The element balances for carbon, oxygen, hydrogen, nitrogen and argon can be seen below in equations (C.1) to (C.5).

