

Master Thesis

LUTMDN(TMMV-5274)/1-57/2016SE



LUND UNIVERSITY
Lund Institute of Technology

Integrated System for Machining Process Visualization and Analysis in Blade Applications

Pontus Westlin

2016

DEPARTMENT OF MECHANICAL ENGINEERING
LUND INSTITUTE OF TECHNOLOGY

Abstract

The manufacturing industry is heading towards a more digitized environment. Sandvik Coromant is therefore developing intelligent tools, as well as software tools for machining applications. The aim for this thesis is to develop the understanding of a specific machining process. This is done through a background study of previously known methods, followed by development of a demonstrator to integrate machining data, and finally a case study to visualize a process.

Continuous development of methods and approaches are required to provide efficient manufacturing processes. Simulations of a machining process is a helpful tool to gain knowledge about relationships between process data and the machining results. Verifying the simulation results is a challenge, especially since every application has its own requirements. Therefore, a case study is performed during this thesis work for the selected application.

A demonstrator for an integrated system has been developed using Integrated Feature based Metrology (IFM), which is an internally developed concept for connecting data from different machining stages. Pre-process data (digital models and process plans) is connected to in-process data (feed, speed, cutting forces etc.) as well as post-process data (geometric evaluations of the finished component). Deviations and correlations that can cause machining problems can be detected and analyzed through alignment of these types of data.

The developed demonstrator shows that it is possible to connect data from the three machining stages. A case study is included, where three blade machining processes are performed. Blade design, CAM software, machine and control system are unchanged, but the cutting data is altered for the different blades. Axis positions and feed rates are acquired from the machine control system, along with cutting forces, torques and vibrations from external sensors, to illustrate how the behavior changes for different cutting data. Most notably, the feed rate is varying more as its nominal value increases.

Future work includes applying the integrated system for machining processes with more than three axes. More case studies should be performed to further verify the functionality of the demonstrator.

Acknowledgement

This master thesis was performed at AB Sandvik Coromant from September 2015 to February 2016. It was done in cooperation with the institution for Industrial Production at the Faculty of Engineering at Lund University.

I really appreciate all help I have received from everyone who has been involved in any way with this master thesis at Sandvik Coromant, particularly my colleagues at the department of Intelligent Machining. I would like to send a special thank you to Mikael Tedeberg and Tomas Engborg for their involvement during the whole thesis, as well as Sten-Åke Ekström, Peter Eriksson and Anders Ivarsson for their expertise in pre-, in- and post-process respectively.

Furthermore, I am thankful for the continuous help I have gotten from Carin Andersson at the department of Production and Materials Engineering at Lund University.

Words and Abbreviations

Integrated Feature-based Metrology (IFM)	Method developed by Sandvik Coromant to integrate pre-, in- and post-process data for geometrical and data features.
Pre-process	Digital models and process planning for a machining process.
In-process	Actual machining data such as feeds, speeds and cutting forces.
Post-process	Geometric measurements of the finalized component.
Fault Tree Analysis (FTA)	Method for finding root causes and correlations for a manufacturing problem.
Computer-Aided Design (CAD)	Software often used for creating digital models of a component.
Computer-Aided Manufacturing (CAM)	Software for generating machining data such as tool paths and cutting data.

List of symbols

Symbol	Unit	Variable
v_c	m/min	Cutting speed
f_z	mm/tooth	Feed per tooth
a_p	mm	Axial cutting depth
a_e	mm	Radial cutting depth
n	rpm	Spindle speed
v_f	mm/min	Table feed
z	pieces	Number of cutting teeth
D_c	mm	Diameter of cutting tool
D_{cap}	mm	Diameter of cutting tool at actual cutting depth
h_{ex}	mm	Maximum chip thickness
K_r	°	Rake angle / Entering angle
D_3	mm	Largest diameter of the cutting tool.

Table of contents

1	Introduction.....	1
1.1	Presentation of the Company	1
1.2	Background.....	3
1.3	Problem definition	4
1.4	Purpose.....	5
1.5	Limitations	5
1.6	Structure of the report	6
2	Method	7
3	Theory	9
3.1	Metal cutting	9
3.2	Machining stages	14
3.3	Integrated Feature based Metrology.....	19
3.4	Fault Tree Analysis	21
4	Execution	23
4.1	Visualization program.....	23
4.2	Case study – visualized machining process	25
4.3	Fault Tree Analysis	33
5	Results.....	35
5.1	Demonstrator for visualization.....	35
5.2	Results for the case study.....	42
6	Discussion.....	49
7	Conclusions.....	51
7.1	Conclusions.....	51
7.2	Future work.....	51
7	References.....	53
8	Appendix.....	57

1 Introduction

This chapter introduces Sandvik and its five business areas. It also presents the background and purpose of the thesis, along with the structure of the report.

1.1 Presentation of the Company

Sandvik AB consists of five business areas: Sandvik Construction, Sandvik Machining Solutions, Sandvik Materials Technology, Sandvik Mining and Sandvik Venture. The following section gives a short introduction of the company and its history, along with a presentation of the different business areas in general and Sandvik Coromant, a company within Sandvik Machining Solutions, specifically.

1.1.1 Sandvik AB

Sandvik AB is a high-tech and global engineering group. The company offers advanced products and services which enhance productivity, profitability and safety for the customers. The operations are based on expertise in materials technology and insight into industrial and customer processes. Sandvik has world-leading positions in the areas of:

- Tools and tooling systems for metal cutting, as well as components in cemented carbide and other hard materials.
- Equipment and tools for the mining and construction industries, along with various types of processing systems.
- High value-added products in advanced stainless steels, special alloys and titanium, as well as metaling and ceramic resistance materials.

The group has more than 47,000 employees representing more than 130 countries worldwide, and sales of about 89 billion SEK. Based on invoiced sales, Europe is the biggest market area and mining industry is the largest customer segment [1]. Their vision is to set the industry standard, which will be achieved through technology and expertise, as well as through the employees and the relationships with customers and stakeholders. The vision enhances the importance of constantly striving toward being the leader in the chosen segments. Sandvik's core values are customer focus, innovation, fair play and passion to win. These are built on the heritage of the company, and aims to support the future ambitions.

Sandvik was founded in 1862, first named Högbo Stål and Jernwerks AB, later Sandvikens Jernwerks AB and then Sandvik AB since 1972. The founder, Göran Fredrik Göransson, was the first to use the Bessemer method for steel production on an industrial scale. The manufacturing of stainless steel started in 1921, and cemented carbide in 1942 [2].

Sandvik Machining Solutions is the largest of the five business areas, based on invoiced sales, operating profit and number of employees. It is a market-leading manufacturer of tools and tooling systems for advanced industrial metal cutting. Focus is on increasing customer productivity by providing products, solutions and application knowledge.

Sandvik Mining is a leading global supplier of equipment and tools for the mining industry, with the most complete product program in the market. They offer products for rock drilling, cutting and crushing, loading and hauling, recycling and materials handling of rock and minerals.

Sandvik Materials Technology is a world-leading manufacturer of products in advanced stainless steels and special alloys for industries such as oil and gas, nuclear and chemical. The safety and efficiency of processes are increased, while the environmental impact is reduced, through development of new materials in close collaboration with their customers.

Sandvik Construction delivers equipment, tools and service for breaking, drilling and crushing in the construction industry. They can be found in tunneling, quarrying, civil engineering, demolition and recycling applications, with products like rock tools, drill rigs, breakers, bulk materials handling and crushing and screening machinery.

Sandvik Venture creates opportunities for growth for small to medium sized businesses in attractive and fast-growing industries [3].

1.1.2 Sandvik Coromant

AB Sandvik Coromant is a part of the business area Sandvik Machining Solutions. The company, who has 8,000 employees, is the leading supplier of tools, tooling solutions and knowledge to the metalworking industry. Unique innovations are developed to increase productivity through extensive investments in R&D, strong industry knowledge and close customer relationships. The main business segments are aerospace, automotive and energy industries [4].

Sandvik Coromant is adapting to the digitizing environment through development of intelligent tools, which will allow faster and more reliable decisions through data stream management [5].

1.2 Background

Sandvik Coromant manufactures and develops cutting tools and tool holding systems for a wide range of areas within the metal cutting industry. Also, they develop methods for specific applications. Such applications may be machining of a certain material or manufacturing of a type of product. Furthermore, the company develops software tools for different machining applications. Adveon™ is a general cutting tool data management software that allows tools from any supplier to be imported to a CAM program. There are also software developed for specific applications, such as InvoMilling™ for gear milling and SpiroGrooving™ for grooving.

The market's demand for efficient manufacturing processes is increasing. New methods and approaches are required in order to provide efficient manufacturing processes, with more sustainability and higher flexibility than before. Software tools and systems are available to support simulation during product development and production. However, every component has its own difficulties and requirements, so a general simulation method may not be applicable. A challenge is how to verify simulations of a machining process based on process data. Another challenge is to develop models to analyze cause-effect relationships.

Sandvik Coromant has developed a method called Integrated Feature based Metrology, IFM, to make it possible to measure, present and evaluate machining data from sensors and geometric measurements along with a nominal CAD model. Both geometrical information and sensor data are included in the term feature. The concept integrates feature data from pre-process, such as digital models and process planning, with in-process data such as feeds, speeds and forces, as well as quality evaluation data from the post-process stage. This concept has, however, not been applied on blade or blisk machining applications yet.

The aerospace industry is a demanding market with complex components, difficult to machine materials and high demands on quality. Therefore, it is important to detect where machining errors occur through monitoring, and be able to change the strategy causing problems.

A blisk, see Figure 1, is an aerospace component that requires great stability in the machining process, along with high quality on the finished product. Blisk is short for blade integrated disk, and there are dozens of them in a single jet engine. One engine needs blisks suited for temperatures ranging from below zero to more than fifteen hundred degrees Celsius. Therefore, blisks of lightweight titanium are used along with heat-resistant super alloy blisks. A blisk consists of mainly two features, the disk and the blades. These may be welded or machined from a solid workpiece. The latter method is becoming more common because of its improved aerodynamic properties and resistance to fatigue. However, a solid blisk entails new machining problems, since some have blades placed so tight that the accessibility of the cutting

tool is reduced. The distance between blades, as well as their height, varies depending on the placement in the engine. The variations in material and dimensions may require different machining methods for the optimal result.

It is advantageous to be able to compare the pros and cons of alternative process plans and machining strategies, in order to find the optimal method for a certain blisk configuration. The blades of a blisk have a complex, double curved shape, and need to be manufactured in machines where the cutting tool can move and rotate with a high degree of freedom.



Figure 1: Picture of a blisk [6].

1.3 Problem definition

Monitoring a machining process through visual examination is desirable in order to find out causes and effects of occurring deviations. It is also helpful for comparing different machining strategies. Problems can emerge due to an inadequate choice of machining method, but what causes the method to be poor is not always obvious. Troubles during manufacturing cost both time and money, so it is important to find them as soon as possible. Therefore, it is helpful to visually illustrate factors that may cause machining problems, and examine if one of these factors cause the tool or workpiece to behave in an unanticipated way. What causes trouble varies due to several factors, such as tool selection, machining order and workpiece material as well as cutting data. This makes application knowledge important in order to acquire and visualize the accurate machining information.

The visualization of the machining process can be performed using the IFM concept. One problem with this method is how to handle all data from pre-process, in-process and post-process. Another problem is how to align the data in time and position.

Machining a blisk requires an advanced machine where the tool can move with both high precision and in several degrees of freedom. The focus in this master thesis is on blade machining, so a model with similar characteristics, and therefore also similar machining methods, to a blisk is used. The component, henceforth called a blade, is designed with single curved surfaces, which makes tool engagement easier. Another simplification is that it is attached to a solid, rectangular workpiece, instead of a circular disk, like in the blisk case. The selection of a geometrically simpler component is done for several reasons, such as the extensive operation time of a blisk and the fact that the material is often expensive. However, the main reason for using blade machining is the machine availability to perform the experiments. The system for acquiring synchronized machining data is only available at a few machines. Those machines can't handle the complexity of a complete blisk machining process, but they are well suited for blade machining.

1.4 Purpose

The purpose of this master thesis is to develop a demonstrator of a tool to supervise a machining process. The demonstrator should act as a proof of concept for an integrated system for machining process visualization and analysis in blade applications. Pre-, in- and post-process data should be combined according to the IFM concept. The system will enable identification of effects, consequences and problems of a machining method, and can be used to find root causes of errors or deviations, as well as compare different machining strategies. A case study for blade applications will be performed to verify the functionality of the demonstrator.

The scope is to develop a demonstrator based on the IFM concept which integrates data from before, during and after a machining process.

1.5 Limitations

Blade machining is the only application to be dealt with in this thesis. However, the method for integrating and visualizing data should be modular, so that the same methodology might be used for studying blisks, and other applications as well, in the future.

The focus in this thesis is on the integrated system, rather than finding the optimal machining method. All tests generating data will be done in the same machine, using the same cutting strategy from the same CAM software. Neither the material nor the geometries of the blades will be altered. The cutting tools and holders, as well as the fixturing method, will also remain unchanged. Cutting data, such as feed and cutting speed, is the only change that will alter the result of each blade. The scope is limited to generate data to be able to test the functionality of the developed software module. Consequently, the results is not aiming at analyzing the choice of best possible method, even though such a comparison is possible in the future.

1.6 Structure of the report

The first chapter introduces the company Sandvik Coromant and the group Sandvik, as well as the background, purpose and limitations for the thesis.

The next chapter explains the approach of the thesis, where the choice of method is introduced.

Chapter three describes the theoretical background of tools used in this thesis. The three process stages pre-process, in-process and post-process are defined, along with the IFM method that integrates them for process analysis. General information regarding metal cutting is provided, along with a presentation of the application blisk machining and how it relates to the components machined in this work.

The fourth chapter gives detailed information about the execution of the thesis. Choices during the progress are explained.

A presentation of the developed demonstrator is provided in the fifth chapter, along with a case study to verify its functionality.

Discussion of choices and results are included as the sixth chapter of the report. Problems during the thesis, and their solutions, are discussed, together with possible future improvements. The possibilities and limitations of the final software are also presented.

The seventh chapter concludes the execution, results and discussion of the thesis. It also gives recommendation of how to improve the software further in order to suit other applications than just blade machining.

The report also comprises a list of references used during the thesis, and an appendix which explains a part of the work in more detail.

2 Method

This master thesis is going to gather data from different stages of a machining process in order to illustrate the impact they will have on the final component. The acquired data should be integrated into one system, where the coordinate system and time alignments between datasets are particularly important. Graphic visualization of the different datasets can demonstrate problematic areas, and inform where an altered method may be beneficiary. The integrated and visualized data realizes the opportunity to find the root cause to why a product did not meet the quality expectations. Another application for the visualized data may be to find easier and more controlled areas of a feature where the machining speed can be increased in order to reduce the cycle time of a product.

Different strategies for machining a component, in this case a blade, will be explored, in order to find out where there are different solutions available. However, the final result will consist of only one method, and can therefore be called a case study [7]. Aspects that might cause problems during the machining process will be compiled in a Fault Tree Analysis, in order to study root causes for unsatisfying quality results. It is possible to influence chosen methods during this project in order to accommodate the integration of the end product through observation and participation in decisions. This requires in-depth knowledge of available methods and their respective limitations.

An architecture for IFM will be developed, including a method to integrate data from the three machining stages. Previous projects involving IFM will be studied to understand possibilities and limitations with the concept. The background study will also ensure that this thesis is in line with previously used IFM applications.

One part of the thesis work is to develop code for a demonstrator capable of, on the basis of input data from the different phases in a complete machining process, visualizing outcomes of the machining process. The second part is verifying the functionality of the demonstrator through executing a complete machining process in order to generate data. Results from the machining operations will be analyzed and discussed. Since there will be only one machining process, no comparisons between different selections is made. This should, however, be possible in the future.

For the testing of the developed IFM for the new machining application chosen in this thesis work, different sets of data are required:

- Geometrical data for the part to be machined is acquired from the CAD model
- Data from the machining process are gathered through experimental studies using different sensors to monitor different operational parameters
- Data on achieved product quality is acquired through optical measurements

The most important aspect of the acquired data is its quality. There is no point of gathering data from too many sources or at too high sampling rates if its integration and synchronization can't be verified. However, the amount of data has to be enough to demonstrate the performance and behavior of the process.

3 Theory

This chapter will define the three machining stages. It will also present application methods for machining in general and blade machining in particular. The different origins of the process data will also be explained.

3.1 Metal cutting

Metal cutting is a machining method to subtract material from a raw piece. It can be split into two major categories: continuous and intermittent machining. The former process has a constant contact between cutting tool and workpiece, while the latter is in contact less than 50 % of the operation. A continuous method usually have just one cutting edge, while intermittent methods can have one or several edges. Turning and drilling are examples of continuous machining methods, but they might also be intermittent processes if there are slots in the workpiece. Milling and sawing are intermittent processes.

Machining methods may be grouped in different ways as well, one with a rotating workpiece – turning – and another with a rotating cutting tool – milling. There are also combinations of the two, called mill-turning or turn-milling. As shown in Figure 2, the turning process is preferred for applications with axisymmetric workpiece, whereas the milling operation is used for machining flat surfaces, slots, pockets, profiles and complicated surfaces [8].

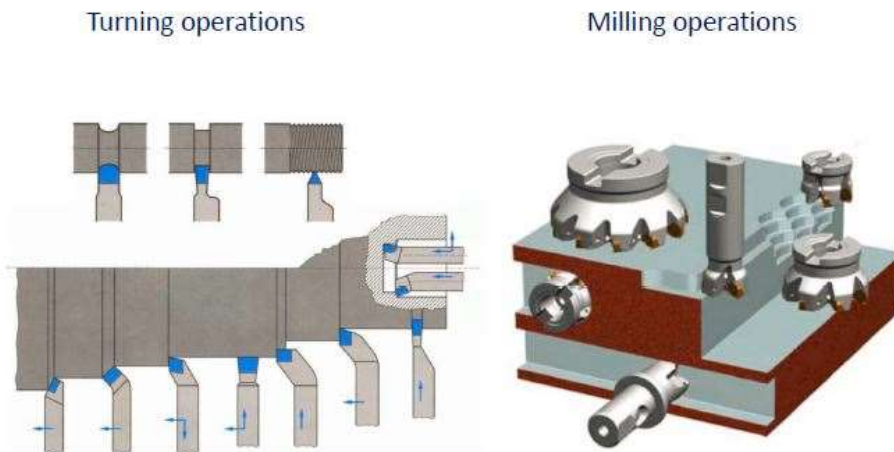

Figure 2: Shows different concepts of turning (left) and milling (right) [9].

3.1.1 Machine configurations

When choosing the machine for the cutting operation, the number of directions the tool can move is of great importance. Each available movement direction is called an axis. The minimal option is two axes, normally a turning lathe machine, where movement normally is available in X and Z direction. A more common configuration is 2.5 axis, which can move in three directions, but only two at a time. The number of axes in a milling machine can be between three and seven, where the most common configurations are three, four or five axes. A three axis mill can perform translational movement in X, Y, Z directions simultaneously. Four, five and six axis machines adds rotational movement in A, B and C, where A rotates around the X axis, B around the Y axis, and C around Z. The seventh axis makes it possible to move the workpiece in order to machine every side of it. The complexity of the detail determines how many axes are needed.

3.1.2 Machining parameters

During machining there are several parameters that influence both the cost efficiency of the process and the machining results in terms of quality. A common name for these parameters are cutting data and they will be explained especially for milling in this section. Formulas described further ahead in this section are only applicable for milling applications, and is used to calculate cutting data. The most important parameters and formulas are described below.

- Cutting speed (v_c , m/min): The peripheral speed at the tool outer diameter where the chip removal process takes place. The cutting choice of cutting speed are influenced by both workpiece material and tool geometry, and the chosen cutting speed influences the process temperature and wear propagation.
- Feed per tooth (f_z , mm/tooth): The amount of workpiece material cut by tooth or insert on the tool. Figure 3 shows a geometric interpretation of the parameter for a tool with six cutting edges.
- Axial cutting depth (a_p , mm): Depth of cut in the axial direction, the stock of material removed when the tool passes over the workpiece. The axial depth of cut determines together with the feed per tooth and workpiece material the cutting forces. The axial cutting depth is limited by the size of the tool or the insert.
- Radial cutting depth (a_e , mm): The depth of cut in the radial direction, or width of cut, that influences the length of engagement and the length of the chip. The radial depth of cut can be equal to the tool diameter, as in slot milling, but usually recommended to be less.
- Spindle speed (n , rpm): Number of revolutions per minute the spindle, and consequently the tool, makes. It is calculated using the recommended cutting speed and the tool diameter (D_c , mm) according to Equation 1. If the tool

cuts at a point not located at its periphery, D_c is replaced with D_{cap} , which denotes the cutting diameter at the current a_p .

- Feed speed (v_f , mm/min): Speed of the movement of the tool in relation to the workpiece in the feed direction. Feed speed can be calculated with Equation 2, using f_z , n and the number of cutting teeth, z [10] [11].

The choice of cutting speed and feed is supported by the cutting tool supplier that e.g. proposes a cutting speed interval for a combination of workpiece material, tool geometry and tool material. These proposals are based on a vast number of machining tests.

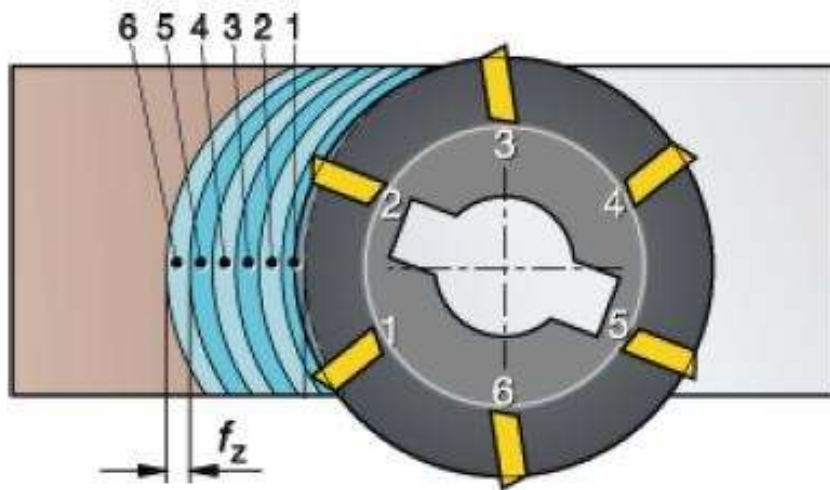

Figure 3: Feed per tooth (f_z , mm/tooth) [10].

$$n = \frac{1000 * v_c}{\pi * D_c} \quad (1)$$

$$v_f = f_z * n * z \quad (2)$$

According to Ståhl [9], the cutting force is mainly dependent on the feed, the cutting depth and the workpiece material. Other factors that may influence the force, to a lesser extent, is the rake angle and the cutting tool material. The cutting speed will impact the resulting force both directly and indirectly, through its influence on the cutting temperature. The force can be divided as shown in Figure 4, where A stands for axial, R for radial and T for tangential direction. All three force components have a linear dependency on the chip thickness.

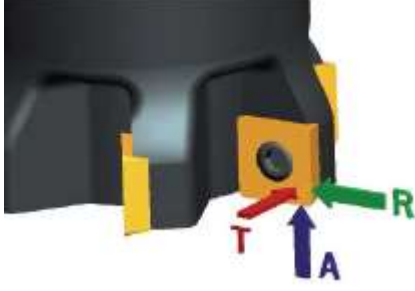

Figure 4: Directions of a force acting on a cutting tool for milling [9].

The chip thickness is calculated in different ways depending on the characteristics of the cutting edges. In applications where side milling is used together with straight edges, the maximum chip thickness (h_{ex} , mm) is calculated according to Equation 3. The thickness depends on the rake angle (K_r , degrees) and the radial cutting depth (a_e , mm). The cutting diameter of the tool at the actual axial cutting depth (D_{cap} , mm), which can be calculated using the axial cutting depth (a_p , mm) with Equation 4 [11]. Definitions of the parameters for straight cutting edges can be found in Figure 5a.

$$h_{ex} = \frac{f_z * 2 * \sin(K_r) * \sqrt{D_{cap} * a_e - a_e^2}}{D_{cap}} \quad (3)$$

$$D_{cap} = D_c + \frac{2 * a_p}{\tan(K_r)} \quad (4)$$

The maximum chip thickness in ball nose end mill applications is calculated using Equation 5, which is different from the previous method, see Figure 5b. At one section of the ball nose, the tool diameter is greater than the diameter of the shaft (D_3 , mm). The maximum cutting diameter at a specific axial depth is given by Equation 6. Definitions of the radial cutting depth for face and side milling is shown in Figure 5c and Figure 5d.

$$h_{ex} = \frac{f_z * \sqrt{D_{cap}^2 - (D_{cap} - 2 * a_e)^2}}{D_3} \quad (5)$$

$$D_{cap} = \sqrt{D_3^2 - (D_3 - 2 * a_p)^2} \quad (6)$$

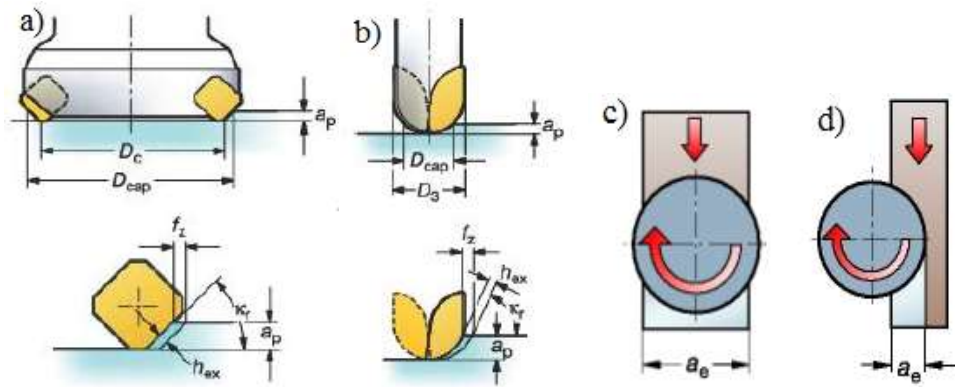

Figure 5: Parameter definitions for cutters with straight cutting edges (a) and for ball nose end mills (b), along with radial cutting depths for different cases (c, d) [11].

3.2 Machining stages

A machining process is defined here as having three stages – pre-process, in-process and post-process [12].

3.2.1 Pre-process

The pre-process stage of machining occurs before the actual machining. It is a planning operation where the components are designed, machine and tools are chosen, and tool paths and cutting data are set. The stage also defines what kind of measurements that should be carried out in subsequent stages.

3.2.1.1 *Design*

Design is the process of deciding attributes for the component that will be machined. The complexity differs depending on multiple factors. Some projects need research of the component in order to find the critical elements, while other components can be designed more freely, depending on the objective of the project. The advanced projects need to find out how every feature of the component affects the performance of the finished product. Such information may be the size and tolerances of shafts, holes or pockets to fit another component correctly. Other aspects to consider can be how height-to-width ratio impacts component stability, how angles are related to aerodynamic problems, or which material is most suitable for the application.

Computer-Aided Design, CAD, is most likely used to design the component. For most products, there are several CAD programs to choose from. The choice of program can be based on what is available in the company and what the designer personally prefers. The design software is not interchangeable by default, so the same program should preferably be used for the complete designing process. However, the design can be exchanged to other programs using standard ways to represent model-based 3D engineering data such as the ISO 10303-242 [13]. The standard describes geometries of a model in a general way, and it is available for all CAD programs.

Another way to export design data for general access is through triangular representation in a stereolithography, STL, file. The file contains surface information of the part through points grouped by three who describes the vertices of each triangle [14]. An increased number of triangles yields a better approximation of the model, but also increases the file size.

3.2.1.2 *Process planning*

The process planning decides machining methods and the fixturing strategy, as well as tool paths and cutting data. There may be several methods to manufacture a component, and application knowledge is required to choose the best solution for current conditions. In most applications, Computer Aided Manufacturing, CAM, is used to create code for the CNC machine. The software often have pre-programmed strategies where some settings can be altered. These strategies will generate a tool path which will depend on the length and diameter of the cutting tool, as well as its number of cutting edges. It is common to perform the machining operation with constant tool engagement, if possible, in order to avoid problems related to entrance and exit in the material. In roughing operations, the problem is mainly a more rapid tool wear and residue material, while in finishing operations it is desired to avoid entrance and exit marks on the finished surface.

The fixturing strategy is important for several reasons. Firstly, it has to make sure that the component is fixed in all directions so it does not move during machining, even though there may be high forces involved. The fixture also has to be rigid in order to avoid dents from the workpiece. It may have to be designed for specific applications in order to be able to machine all sections of the workpiece to avoid reclamping of the component. Moving may reduce the precision of the machining, since it is difficult to fixture it at the desired position or angle one more time. Some details of the component may need extra support in order to have sufficient stability, and this should be provided by the fixturing device.

There are often several methods available for machining a component. One example where the chosen method is important is during machining of thin walls, as in blade machining. Thin blades will vibrate if they are too long, but this tendency can be avoided. The blade can be machined as one, or split in several sections with iterative roughing and finishing operations for increased stability of the component, see Figure 6. The stability of the wall increases if more stock material remains at the component, but there may be a clear difference in surface characteristics between two sections. This method may also be used for machining processes where the required material removal depth is greater than the axial cutting depth of the tool.

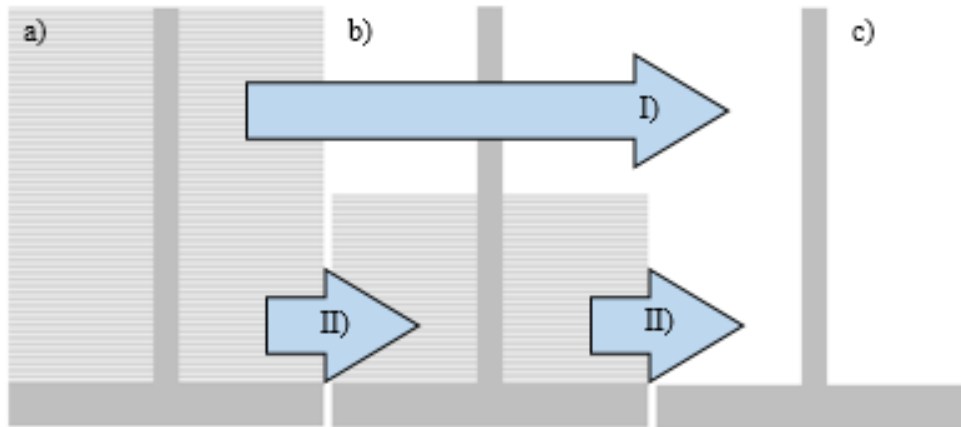

Figure 6: Concept of thin wall machining. The striped areas illustrates stock material to remove. It can be done in one step, from the a) directly to c) as illustrated by method I, or in two steps, from a) to b) and then from b) to c).

In general, the cutting speed is chosen with respect to the workpiece material and tool geometry. Radial and axial cutting depths are mainly limited by the tool diameter and the cutting length respectively. They are also decided considering both workpiece and tool material, along with limitations on the available machine power and torque. The cutting speed and depths, and the tool properties, will generate cutting data such as spindle speed and feed along the tool path. The data can be optimized in order to increase the speed or maintaining a steady material removal rate. This will cause varying speeds and feeds along the way.

The process planning generates a program code for numerical controls, where directions, patterns and speeds are described. The code is often specific for a control system in a numerically controlled machine, and the language may vary significantly between different controllers. It is also possible to extract the machining instructions as a general code, but the general language can't be input to a numerical controller.

3.2.1.3 Resources planning

Before the choice of machine can be done, the geometry of the component has to be known, as described in section 3.1.1 above. For axial symmetric components, it is often sufficient with 2 or 2.5 axes, where X is in the radial direction, Z is parallel to the workpiece axis and Y, if used, is the offset in height from the center of the component. 3 axis milling machines can manufacture simple three-dimensional components. Since all axes can be moved simultaneously, it possible to create rounded corners and curved surfaces. However, it requires free access from the cutting point all the way up to the spindle, which may cause problems in for example slot and pocket machining. The lack of accessibility may also lead to the need of multiple time-consuming and precision-reducing setups.

Four axis machining makes it possible to rotate either the workpiece or the tool. This increases the reachability of the tool, and will therefore improve machining possibilities for components with cavities. By adding a fifth axis, it is possible to rotate the tool and the workpiece simultaneously. This makes it possible to machine complex geometries. Additionally, the tool can be tilted so that the material removal occurs further away from the tool center, which increases the cutting speed. This method will improve tool life and generate a better surface finish than the completely vertical tool.

3.2.1.4 Measurement planning

To prepare for in-process and post-process measurements and quality assurance, it is important to plan ahead what parameters that need to be measured. For in-process measurements there are different sensors and tools to choose from to measure most of the characteristics in a machining process, but the measurements should be as few as possible. Therefore, it is important to plan a measurement strategy for both in-process and post-process data. Application knowledge is required to assess which parameters to measure. These parameters may differ from application to application, therefore it is important to understand the reasons for measuring. One reason to optimize the measuring is to avoid excessive size on data files, which reduces analyzing speed and causes storing troubles. Another reason is to lower the economic costs, since the sensors may be expensive.

The measuring of the quality of the final detail should also be defined in the pre-process, in order to ensure that the component can be measured. Some measurement methods for the post-process can be programmed based on the component design. By programming this during the pre-process, time will be saved at later stages.

3.2.2 In-process

The in-process machining stage realizes the decisions made in the pre-process through machining the component along with the planned measurements. In-process data may be cutting forces, axis positions, feed rates or torques.

Cutting forces are measured as three components in an orthogonal coordinate system from external sensors. The coordinate systems in sensors may differ from the machine coordinate system. Therefore, it is important to know how they are related, in order to transform all data into the same coordinate system. Sensors may also register torque on one or more of the axes.

Using external sensors may cause changes of the machining process. Stationary devices can be attached to the fixture, meaning it has to be at least as rigid as the fixture in order to avoid changes of the workpiece behavior. Moving devices are usually connected to the cutting tool or its holder. This increases the length between

the cutting edge and the rigid spindle, which will increase the risk of deflections and vibrations on the tool.

In-process data can also be acquired directly from the servo motor of the machine. Such data may be tool positions, feed rate and spindle speed.

3.2.3 Post-process

Geometric measurements are made in the third machining stage. These measurements are used to evaluate the actual result to the planned one. This comparison gives feedback to decisions earlier in the machining process, such as method and cutting data selection. If several different strategies are used, it is possible to find the best among them. The evaluation can also be used to identify problematic sections of the component. In the case of a blisk, a problematic section might be the edges.

There are two general methods to measure a component; by contact and optical measurements. A coordinate measuring machine, CMM, generates results through moving a probe over the surface to be measured that records data along the movement path. The machine can measure a specific point by a simple probe-component contact, or a cluster of points through dragging the probe over a surface. It is also possible to measure the component without contact through usage of a laser scanner instead of the probe. The main advantage of the CMM is the high accuracy of the measurement. However, the probe movement has to be programmed, which may take a long time for a complex detail. The measurement of the detail is also time consuming.

An optical measurement device uses a camera that directs a light beam at the component, and gives a result based on the reflected intensity of the light. The camera can record several points with each picture, which means it does not require gathering of data in as many points as a CMM would. This reduces the programming time, which may be a great advantage in low-volume products [15]. The distance between points can be programmed to fit the tolerances of the applications. An increased point density gives higher resolution, but also increases the size of the measurement data, which may cause problems when handling the resulting file. Even though an optical measurement requires no direct contact, the surface of the component has to be prepared with temporary reference points in order to connect different snapshots to each other. Smooth surfaces are often reflective, and has to be covered in a matt layer in order to increase the precision of the measurement. Sections with dark surfaces may also have to be coated [16].

3.3 Integrated Feature based Metrology

Integrated Feature based Metrology, IFM, is a concept developed internally at Sandvik Coromant during a project within the internal CFPC project. This project resulted in two IFM prototypes; one for turning and one for pocket milling [17]. The IFM concept has then been further developed within R&D and applied in other machining applications, but not for multi axis machining such as blade machining.

The idea behind IFM is the possibility to measure, integrate and analyze sensor data in combination with geometrical data from pre-process, in-process and post-process, as shown in Figure 7. Sensor data comes from the in-process stage and might be in the form of cutting forces, process temperatures, torques and power as well as the corresponding tool path during machining. Geometric data, such as dimensions, form and surface characteristics, is acquired from a CAD/CAM system for the pre-process, and from optical or contact measurements in the post-process.

Before the development of the IFM, it was possible to evaluate data from various stages of the machining process, but there was no method to link them together and analyze the complete process. The purpose of evaluating all stages together is to find the root cause of a deviation and visualize correlations between different cutting parameters.

Sandvik Coromant has an internally developed system for extracting machining data from several sensors simultaneously called Coromant Data Transfer, CDT. CDT is a method for one way communication from machine to computer.

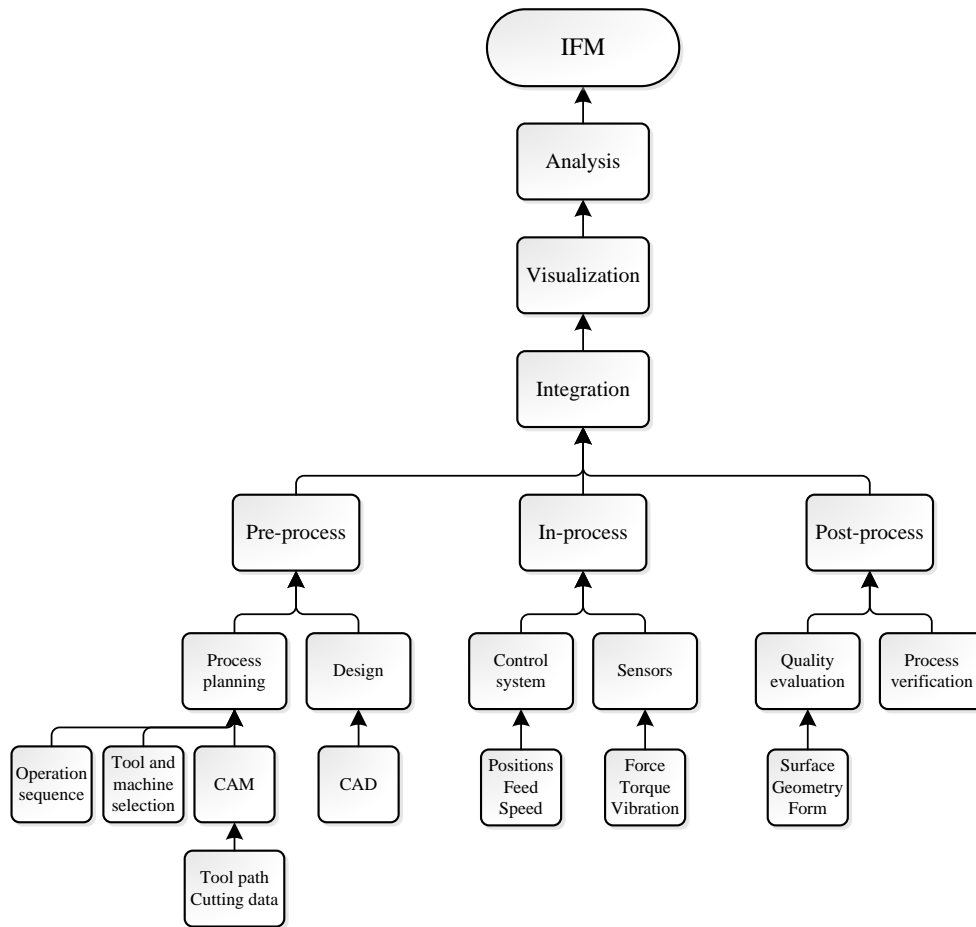

Figure 7: The structural idea of the Integrated Feature based Metrology.

3.4 Fault Tree Analysis

A Fault Tree Analysis, FTA, is a symbolic logic analytical technique for finding problems in a process. It is a graphic model shaped as tree, with the undesired event at the top, and the root causes at the bottom. Root causes are linked to a symptom of a problem, which can be measured in physical terms. Figure 8 shows the general method to depict a FTA. The analysis aims to illustrate problems at every step of the chain leading to the undesired event. It should also serve as a tool to better understand both problems and possibilities of the process [18].

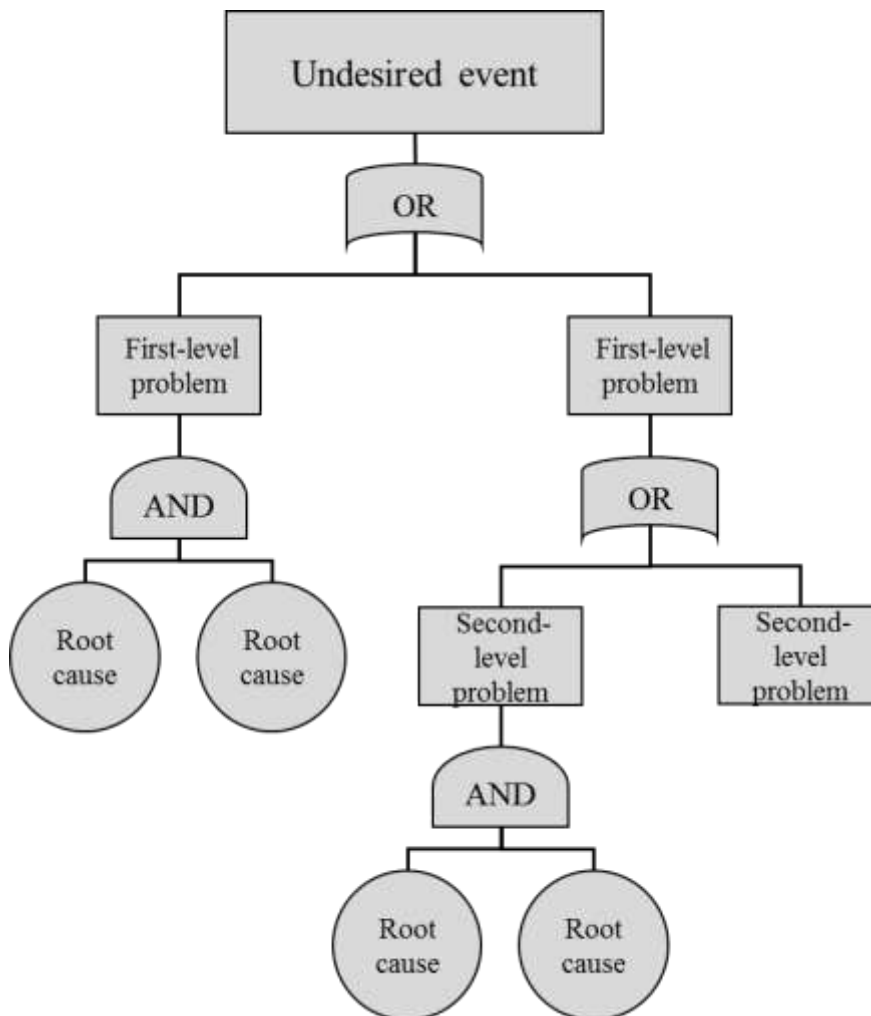

Figure 8: General method to illustrate a Fault Tree Analysis.

4 Execution

This chapter describes the process of the project, and provides explanations for selections made during its completion. The work is divided in two main sections; one for the demonstrator of the visualization, and one for the case study that exemplifies one way to use the demonstrator. Both sections will be further divided into pre-process, in-process and post-process stages.

4.1 Visualization program

The software used to visualize the machining process is programmed in Python, along with its extension MayaVi. It is possible to choose other programming languages, but Python is chosen since it is widely used, and it can handle large amount of data. The extension MayaVi is a powerful tool for data visualization with a lot of opportunities for customization. Data from all systems within the machining process is put into the program, which will extract the relevant information from each file and save the filtered data in new files. All data extraction is general, so it is possible to change input files if different strategies should be tested without reprogramming. Data types from the three machining stages are presented below, and they are compiled together with its file types in Figure 9.

4.1.1 Pre-process for demonstrator

The design of the component is performed in a CAD program, where the data is specific for each software. However, it can be exported as general file types as well. In this case, the data is exported using a triangulation method and stored as an STL-file. The file describes the vertices of every triangle using X, Y and Z coordinates. These numerical values for the coordinates are extracted to a new file, and later visualized using the same triangulation method. This method removes text that is used to explain every row. Results from triangulation will never be as smooth as the original file, but if the triangles are sufficiently small, the visualized design will look good enough.

A CAM software is used to realize the process planning stage. The CAM program generates a file that contains the tool for every operation, as well as all relevant cutting data, such as cutting speed, feed per tooth and radial cutting depth. Path information that describes every movement of the tool is also included, along with the feed rate for every segment of the path. The result from the CAM program is usually converted to a language that is specific for the control system in a machine. However, it can also be exported as a general code, usually with the extension .cl. The feed and tool path data is extracted from this file in order to visualize that information in the demonstrator.

4.1.2 In-process for demonstrator

The in-process data is acquired from the internal data acquisition system Coromant Data Transfer (CDT). Output from the system can be generated with comma separated values, CSV. CSV file types have a similar function as a table, where every column is a data type, for example position of the X axis in the machine or force in the Y direction, and every row has a new measured value. The data can be measured at different sample rates, which means every row will have information for data measured at the highest frequency, whereas gathered at lower frequencies will have rows without information. Measurement planning during the pre-process stage should ensure that relevant data, neither more nor less, is measured. However, machining data may be useful for other analyses as well. For this reason, all gathered data will not be used in for this demonstrator. The visualization program filters the data to remove excessive information. Remaining data is visualized, either as an overview or detailed for a section of the component. The magnitude of quantifiable data is included in the visualization in order to illustrate how it changes during the machining process.

4.1.3 Post-process for demonstrator

Post-process measurements provide geometric form and dimensions for the actual output after the machining process, and are used to asses if the results from the machining process are within the specified tolerances. The comparison is based on deviations in X, Y and Z directions. In order to achieve a truthful comparison, at least one reference point from the designed component need to be measured in the post-process. This will make it possible to align the measured data to design data. The measured data is described in a similar way as the design data, and can also be exported using the triangulation method. However, the triangulated data does not include information from the comparison between the desired design and the actual output. This information can only be exported as a point cloud in CSV file. A mesh is then approximated from the point cloud, where the comparison data is included.

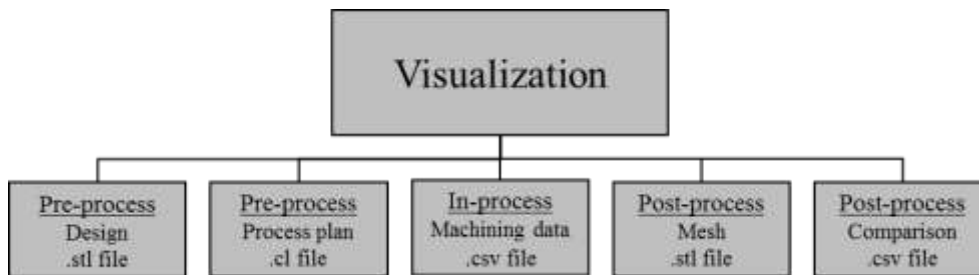

Figure 9: Input for the visualization program together with their respective file type.

4.2 Case study – visualized machining process

A case study is performed in order to verify the functionality visualization program and give an example of its purpose. The component, a blade, is machined in three operations; roughing, semi-finishing and finishing. No measurements are made for the first two, since the focus is on the evaluation of the finishing.

4.2.1 Pre-process for case study

4.2.1.1 Component design

Using Unigraphics NX, the component is designed as a blade in order to get characteristics similar to a blisk. Some of the usual design limitations can be ignored, since this part will not be used after the machining is finished. A blade in a blisk application have specifications for the curvature of the surface, and are designed for optimal aerodynamic performance, resulting in an almost free form surface. Other specifications that may limit the alternatives for machining methods are the height and width of the blades, and, in the case of a solid blisk, the distance between the blades. This blade has a simpler design, with only single curved surfaces; one convex and one concave. The height is limited to the overhang of a standard tool, and is set to 40 mm in this project. In order to improve the reachability for the cutting tool, the blade is designed to be bigger at the bottom than at the top. This also improves the stability of the blade. Figure 10 shows a 3D view of the blade generated in the CAD software, along with definitions for edges and surfaces of a blade henceforth used.

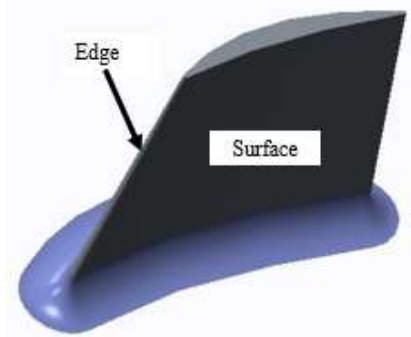

Figure 10: 3D view of the chosen blade geometry generated in Unigraphics NX with definitions of edge and surface, which are sub features of a blade. The height of the blade is 40 mm, and the maximum width is 45 mm.

Even with the abovementioned simplifications of blade curvatures and geometries, the machining process of this blade is comparable to a blade from a blisk. The finishing operation on the edges of the blade are of great interest since it often causes trouble during machining due to the difficulty to maintain the correct feed and tool

path when the tool orientation changes. The edges are important in order to get the correct aerodynamic properties on the finished component.

4.2.1.2 Machining equipment requirements

A simultaneous task to the model design is to choose which machine to use. Since the component is three-dimensional, the machine has to have at least 3 axes with the possibility to move in X, Y and Z directions simultaneously. The lack of double curved surfaces and pockets on the part means that a vertical tool can access everywhere on the surface. Otherwise, a 4 or 5 axis machine would be required. One advantage of designing a component freely, as in this project, is that its size can be fitted to the working area of an available machine. The range of machines would have been narrower if it would have been the other way around, where the size of the component is of practical interest. The data acquisition system is only installed on a limited number of machines, a requirement that reduced the number of available machines. It would be possible to measure the same data without the CDT, but that would require manual synchronization of data.

4.2.1.3 Methods and tools requirements

The machining process is divided into three operations; roughing, semi-finishing and finishing. The roughing operation removes big volumes of material quickly, while maintaining a controlled wear on the cutting tool. For this process, a shoulder milling operation is chosen. Flank milling is usually an option for such operations, but it is not used in this project since the method is unavailable for machining of the double-curved surfaces of a blisk. In order to maintain similar machining characteristics as in blisk machining, point milling is chosen. The tool has to be engaged from above, since a side entry method is not able to reach to concave side of the blade. The CAM program used to generate the tool paths and cutting data is Unigraphics NX.

First of all, the selected tool has to be harder than the workpiece material in order to perform the cutting operation in a satisfying manner. However, tools in hard materials tend to be become more expensive, which means it is not always an economical solution to have the hardest tool. For intermittent operations, the tool has to be tough in order to not break at tool entrance, but also hard enough to avoid a rapid wear. Because of the high material removal rate in roughing operations, the chosen tool should withstand high cutting forces. This means it is advantageous to have a relatively large tool diameter in order to avoid deflections. If there are significant deflections during the machining process, instability may be introduced on either the workpiece or the cutting tool. Sharp cutting edges for tools in roughing operations should be avoided, since those may be cause risks of breakage at the cutting edges.

Tools for finishing operations should have sharp cutting edges, since they will generate a smoother surface. The last operations of a machining process are

removing less material, so the tools don't have to withstand as high cutting forces, which means smaller diameters can be used. A smaller diameter also means that the reachability improves, which is of great importance for applications where the blades are close to each other, particularly if the tool can be rotated as in four and five axis machining.

4.2.1.4 Choice of machining equipment

The chosen machine, a DMG Mori NV 5000 α 1, is shown in Figure 11. It is a 3-axis milling machine with CDT integrated, which were the main requirements for this project. The maximum speed of the spindle is 15000 r/min, and it can handle tools with a weight of up to 15 kg [19]. The control system is MSX-501, which is a kind of FANUC controller.



Figure 11: Picture of the chosen machine: DMG Mori NV 5000 α 1 [19].

The chosen workpiece material is SS-2541 (DIN EN: 34 CrNiMo6), which is a low-alloy steel common for machining tests. The raw material is prepared with holes, as shown in Figure 14, to be able to attach it to the dynamometer.

A CoroMill® Plura solid carbide square shoulder end mill, R216.24-16050CCC32P 1620, is selected for the roughing and semi-finishing operations. It is shown in Figure 12a [20]. The tool diameter is 16 mm, and its maximum axial depth of cut is 32 mm. Since the blade height is greater than the allowed axial depth of cut, it has to perform the roughing operation twice, at different levels, as described in Figure 6. The tool is attached to an adapter, CoroChuck 930-C6-HD-32-091. The adapter grips the tool with a HydroGrip Chuck, and is connected to the spindle through a Coromant Capto® C6 at the other end. The tool can handle rotational speeds of up to 80000 rpm, while the holder endures 20000 rpm, which both are higher than the limit of the machine at 15000 rpm.

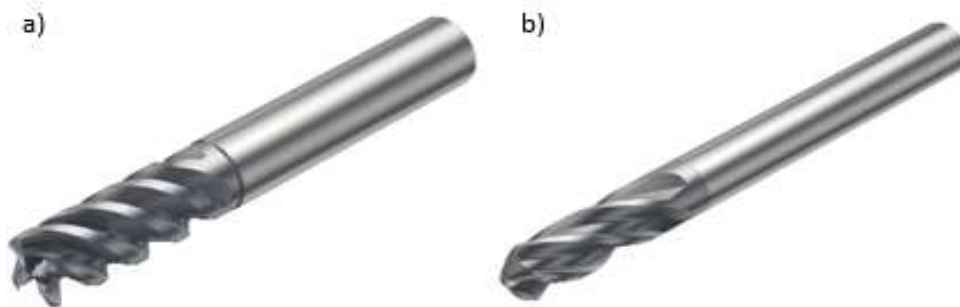

Figure 12: Tools used for roughing and semi-finishing (a), and finishing (b) [20] [21].

For the finishing operation, a different solid carbide CoroMill® Plura is selected. This tool is a ball nosed end mill denoted R216.44-10030-AK22N 1620, and is shown in Figure 12b. The tool diameter is 10 mm [21]. The involvement of a rotating dynamometer, which is described in more detail in section 4.2.2, for the finishing operation limits the rotational speed to 5000 rpm. The tool path creates a spiral from the top of the blade to the bottom, where the tool is in constant engagement with the workpiece.

Table 1 contains cutting data for the finishing operation. The values are varying for the blades in order to examine the impact of the changes on the finished component.

Table 1: Cutting data for the finishing operation at blade 1, 2 and 3.

Parameter	Meaning	Unit	Blade 1	Blade 2	Blade 3
D	Tool diameter	mm	10		
z_n	Number of teeth	pcs	4		
v_c	Cutting speed	m/min	100	150	150
f_z	Feed per tooth	mm	0.03	0.03	0.04
n	Rotational speed	rpm	3183	4775	4775
v_f	Table feed	mm/min	382	573	764

4.2.2 In-process for case study

During the machining experiments two different parameters are measured; cutting forces and vibrations. For this purpose, two different cutting force sensors are used for data acquisition in this machining process, despite the earlier mentioned desire to avoid excessive data. Both are used in order to test the functionality of the demonstrator on as many data sources as possible for a machining process. The vibrations are measured by an accelerometer, mounted on the base of the workpiece.

The piezoelectric Kistler 9255B, which is a stationary dynamometer, measures the three orthogonal force components. It consists of several internally placed sensors. Each sensor has three pairs of quartz plates, one to register the pressure as a passive force parallel to the axial (Z) direction, and the other two register shear tension as forces in X and Y directions in the active plane [22]. Figure 13a shows a Kistler dynamometer of model 9255C. The used 9255B and the pictured 9255C look the same; the only variation between the models is the measuring range [23].



Figure 13: Pictures of the stationary 3-component dynamometer, model Kistler 9255C, (a) and the rotating 4-component dynamometer, model Kistler 9124B (b) [23] [24].

A rotating 4-component dynamometer, Kistler 9124B, pictured in Figure 13b is attached to the spindle. It measures the forces on the cutting tool in an orthogonal coordinate system, as well as the torque on the Z axis [24]. The orthogonal forces are measured in the same way as for the stationary dynamometer, but the coordinate system moves along with the rotational dynamometer. Shear-sensitive plates are added in a circular pattern at a fourth pair of quartz plates in order to measure torque [22].

A total of three blades are machined during the test, with varying cutting data in order to compare how different feed rates and speeds will impact the quality of the component. The numbering of the three blades are shown in Figure 14, along with an illustration of the outlines of the raw workpiece, as well as the placement of the accelerometer that registers vibrations. All three blades are milled from a solid

workpiece. The four holes are used to attach the workpiece directly to the dynamometer, without using a traditional fixturing device, thus reducing the weight. This method avoids usage of components with less rigidity than the measuring device.

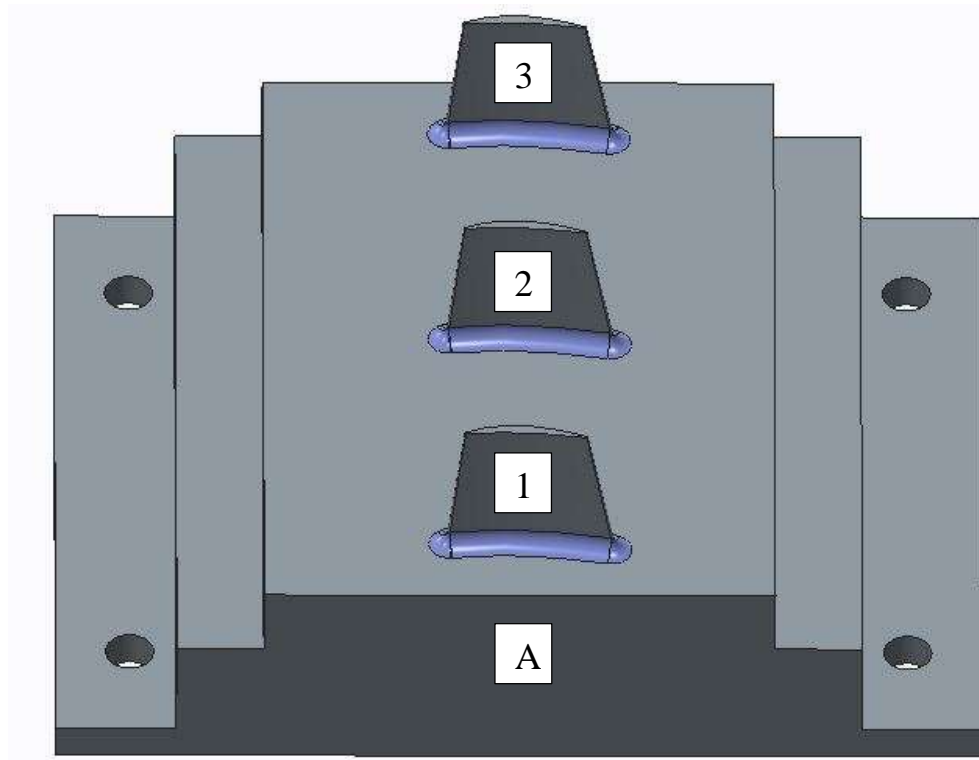

Figure 14: Numbering of the machined blades, as well as the accelerometer (A).

The internal data acquisition system, CDT, is used to register data from the available sensors. Forces in X, Y and Z directions are registered from both the stationary and the rotating dynamometer, along with a torque around the Z axis from the latter. The CDT also collects accelerometer data in two directions. Other in-process data, such as spindle speeds, feed rates and axis positions linked to the tool path, comes from the servo motor of the machine.

Measurements are only made for the finishing operation, since it is the characteristics of the finished component that are of interest. Sampling frequencies are varying; the highest sampling rate is 10 kHz for the accelerometer, while the data from the two dynamometers are sampled at 5 kHz, and the lowest frequency is 200 Hz for the control system data. However, all data for the visualization is filtered, and shows information at the lowest frequency of 200 Hz.

Figure 15 shows all components in the machining process set-up, along with positive directions and origins for their respective coordinate systems. Letters are indexes for different components, and Roman numbers describes coordinate systems. The X and Y directions of the rotating dynamometer are dynamic and will rotate as the dynamometer rotates. The rest of the coordinate systems are stationary, and will be transformed to the coordinate system of the component for the visualization process. Table 2 offers descriptions for the symbols shown in the figure.

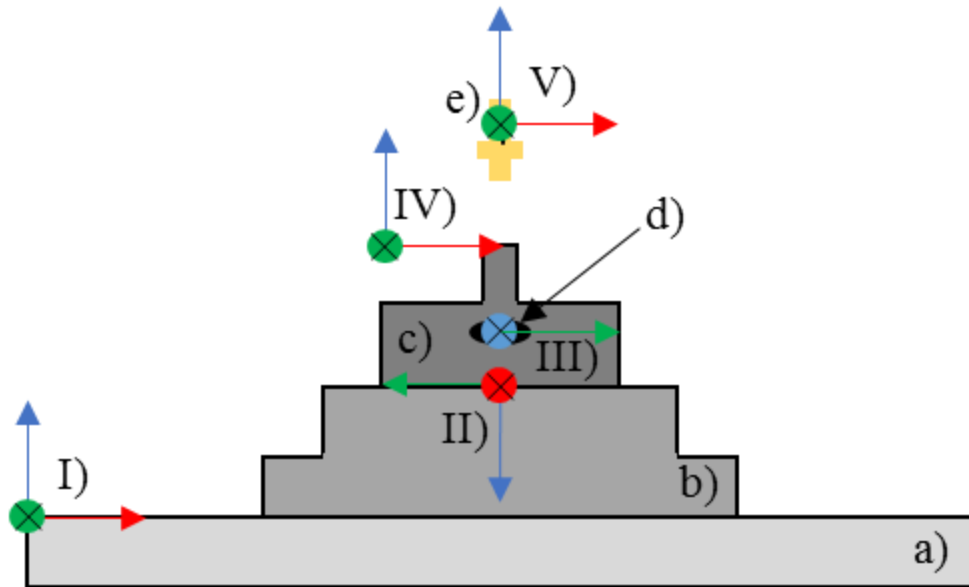

Figure 15: Illustration of machining process components and their coordinate systems. The arrows indicates the positive directions, and red corresponds to the X axis, green to Y and blue to Z.

Table 2: Descriptions of symbols and Roman numbers shown in Figure 15.

Symbol	Component	Coordinate system
a)	Table of the machine.	I
b)	Stationary dynamometer.	II
c)	Workpiece component, with visible blade.	III
d)	Accelerometer	IV
e)	Rotating dynamometer and attached cutting tool.	V

4.2.3 Post-process for case study

Optical post-process measurements are chosen for this machining process because of its flexibility. A coordinate measuring machine has to be programmed in order to know how to move along the geometry to be measured. The programming time is often notable, which means it is not the optimal option for low volume products. In optical measurements, the component can be moved manually, which can be advantageous when certain sections need closer attention than others.

Components with smooth surfaces can appear glossy, which causes problems for optical measurement systems. Therefore, it is coated with a thin layer of titanium oxide in order to reduce the reflecting lights. The surface will also be covered with temporary stickers, which are used for relating different pictures taken with the cameras of the measuring system to each other.

The form and dimensions of the blades are measured with an ATOS III Triple Scan system from the company GOM, see Figure 16. Its two 8 MP cameras takes snapshots of the same area from slightly different angles, which increases the precision of the results [25]. The accuracy during these measurements is set to 0.036 mm. A milled reference point at the origin of the coordinate system of the CAD model has been used to align the pre-process and post-process data, along with information about positions of all three blades.



Figure 16: ATOS III Triple Scan for post-process measurements [25].

4.3 Fault Tree Analysis

A Fault Tree Analysis, FTA, is performed for blisk applications in general, which can be seen in Appendix A. It is based on existing knowledge regarding manufacturing difficulties and problems, as well as important quality aspects to fulfill. The reason for this analysis is to provide a tool that can be combined with the visualization program for examining a machining process. The analysis can be verified through tests with different set-ups and background conditions.

Figure 17 **Fel! Hittar inte referenskälla.** shows a condensed version of the full analysis. This machining process focuses on the obtainable quality, rather than testing the limits of the cutting tools and the machine. Therefore, one of the first level problems, failure, is completely removed. Neither stress nor hardness are measured in this work, and are subsequently removed from second level problems from this FTA. Some third level problems are mentioned, but more may be added as more machining tests are performed. The machine stability includes both inertia at low speeds and rigidity at higher speeds. Other problems may, for example, be caused by the lack of precision in the CAM software. Not all of the root causes mentioned in this analysis have a notable effect on this machining process, but are included here since they can be analyzed using the visualization tool in further work.

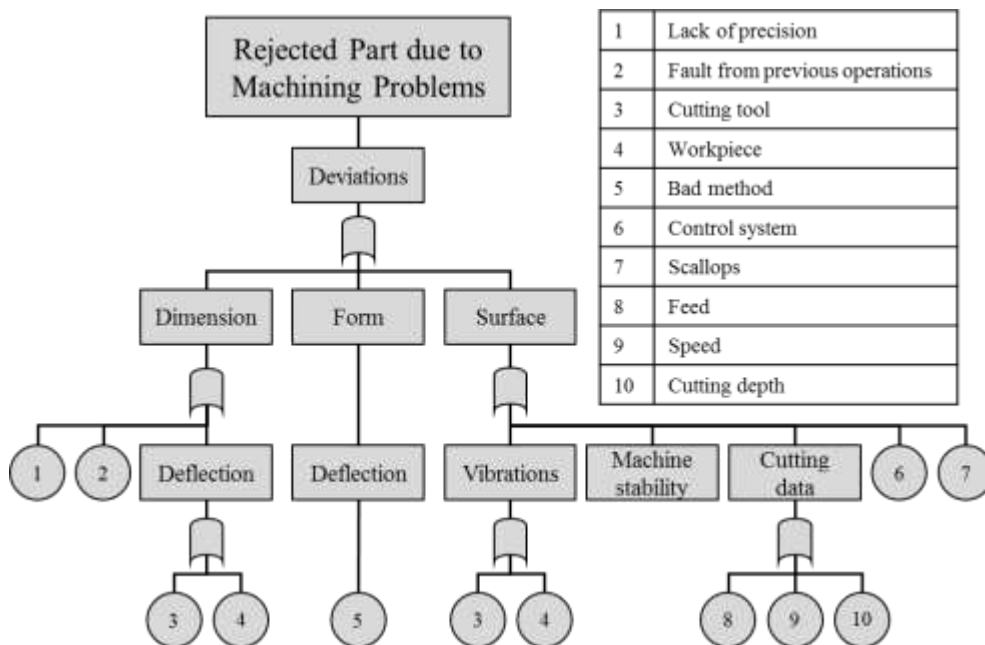

Figure 17: Fault Tree Analysis of a blade machining process.

The numbers indexing the root causes are described below.

- 1) Lack of precision, meaning the cutting tool has a different position than planned. May be due to insufficient rigidity of the tool, its holder or the spindle, causing a slight angle between the actual and desired cutting position.
- 2) Fault from previous operations points out that too much material has been removed during earlier machining stages. This may be caused by relocating the workpiece while changing fixture or machine.
- 3) The cutting tool may be too weak for the current cutting applications. This can occur if the diameter is too small, or if the hardness of the tool material isn't sufficient compared to the workpiece material.
- 4) The workpiece may, in a similar way as above, be too hard for the chosen cutting tool. Components with thin sections are easily deflected. Therefore, it is important to keep cutting forces in such applications low. Problems can also occur due to too much material left to remove.
- 5) Bad method indicates that one or more method for the cutting process leaves an insufficient result. This problem can be indicated through high cutting forces during the machining. The availability for method development is one of the major reasons for analyzing a certain application, because it enables the opportunity for improved application knowledge.
- 6) Different control systems calculate the tool path with varying velocity, and it is therefore important to identify if there are systems that can't handle machining applications with high speeds.
- 7) Scallops are a machining setting that describes the step-over from one lap of machining to the next one. Increasing the scallop means the distance between each lap will increase, and therefore result in a shorter machining time. However, it may cause a rougher surface.
- 8) Feed rates during machining have a close connection to the generated surface. Higher feed means a shorter machining time, but it has to be ensured that this have no negative impact on the surface of the component. Analysis can also be performed to find out how beneficial an optimization of a cutting process is.
- 9) The spindle speed can be alternated in a similar way as the feed, even though its relations to generated surface isn't as clear.
- 10) Both axial and radial cutting depths affect the generated surface, mainly because the parameters decide how much material that are removed during a cutting operation.

5 Results

This chapter presents results from the development of the demonstrator which are separated from the results from the machining for the case study. Both types of results are based on the same data, but the different types highlight different aspects of the result.

5.1 Demonstrator for visualization

Figure 18 illustrates one view from the visualization software. The CAD design of a blade, and its base, will always be shown as a visual reference to other data. In this section, all figures will show data from the third blade, because these results shows most variations. The coordinate system is also visible, where the red arrow corresponds to the positive X direction, green arrow to the Y axis and blue to Z. All coordinate systems are transformed to this, in order to show directions correctly.

There are buttons below the visualization area that control what data to show, since showing all data at once will cause confusion. For the same clarification reason, it is also possible to show parts of the in-process and post-process data using the handles at the second-bottom and bottom of the figure respectively. The red section contains pre-process information, the green section is for in-process, and the blue for post-process data.

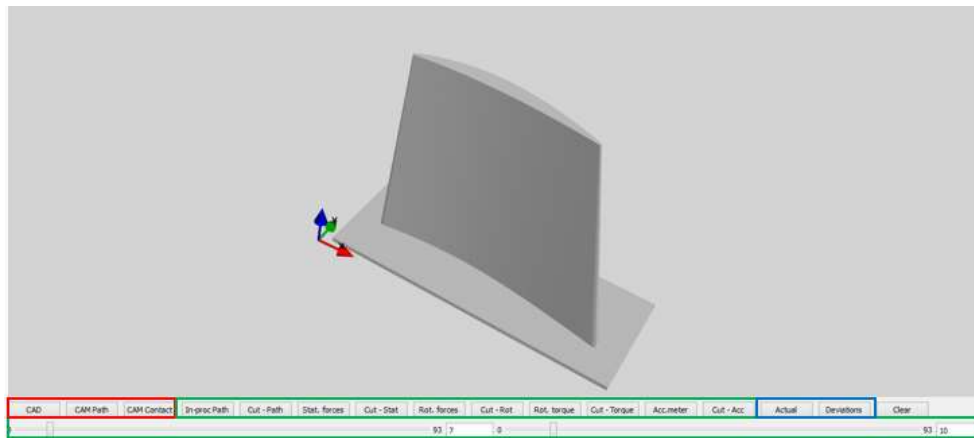

Figure 18: Basic visualization of one blade and its coordinate system.

The buttons in the red, green and blue sections in Figure 18 are further described in Table 3.

Table 3: Description of buttons in the demonstrator shown in Figure 18.

Process stage	Button	Button description
Pre	CAD	Toggle visibility for the designed component.
Pre	CAM Path	Visualizes center points of the tool for the CAM generated tool path.
Pre	CAM Contact	Visualizes the contact points between tool and workpiece for the CAM generated tool path.
In	In-proc Path	Illustrates the actual tool center positions during the in-process measurements.
In	Cut - Path	Illustrates the actual tool center positions for a specific section of the machining operation.
In	Stat. forces	Shows magnitude and directions of forces measured by the stationary dynamometer.
In	Cut – Stat	Forces from the stationary dynamometer for a specific section of the machining operation.
In	Rot. forces	Shows magnitude of forces measured by the rotating dynamometer.
In	Cut - Rot	Forces from the rotating dynamometer for a specific section of the machining operation.
In	Rot. torque	Shows magnitude of the torque on the rotating dynamometer.
In	Cut - Torque	Torque on the rotating dynamometer for a specific section of the machining operation.
In	Acc. meter	Illustrates vibrations measured by the accelerometer.
In	Cut - Acc	Vibrations measured by the accelerometer for a specific section of the machining operation.
Post	Actual	Visualizes the measurement of the actual component after the machining process.
Post	Deviations	Visualizes deviations between the designed and the actual component.
-	Clear	Clears the scene of all visualized data.
In	-	Handles in the green area decide specific sections for which to visualize in-process data.

The buttons for the pre-process toggle the visibility of the CAD design, the CAM prepared tool path and its points of contact between tool and workpiece, as shown in Figure 19. The green color of the tool path indicates it is keeping the same feed throughout the machining. If a chip thickness optimization would have been done, then the feed would vary, which the visualization is able to illustrate through altering the line color. The magnitude of the feed can then be interpreted from the color bar at the left. The tool path illustrates the movement of the center of the tool.

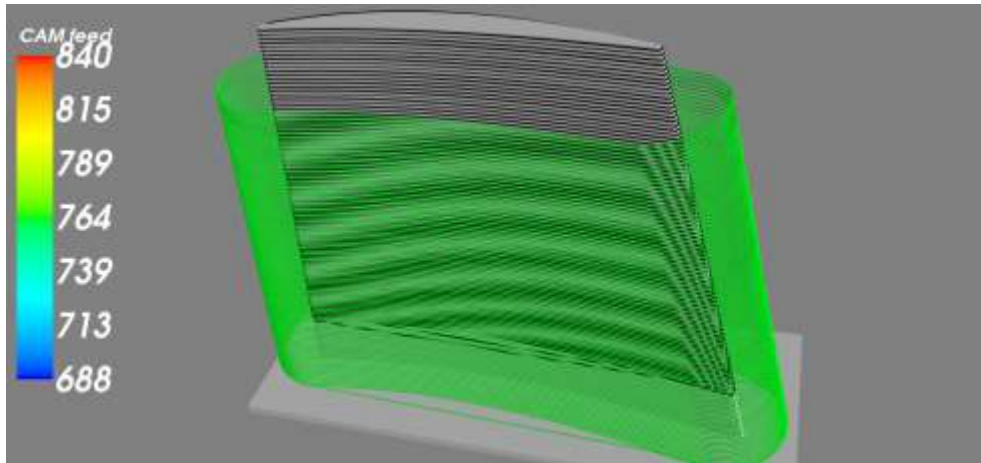

Figure 19: CAM generated tool path and feed (colored) and its contact points (black) along with the designed component (gray). The feed is measured in mm/min.

Similar to the CAM generated tool path and feed visualization in Figure 19, it is possible to illustrate the actual tool path and feed, as shown in Figure 20. The lines are representing the center of the tool. This in-process data is extracted from the control system of the machine. It shows that the feed is lowered at the beginning and end of the edges, even though it is programmed to maintain the same velocity. If geometric variations around the edges is detected at the post-process measurements, this is a probable cause, and the machining strategy has to be changed.

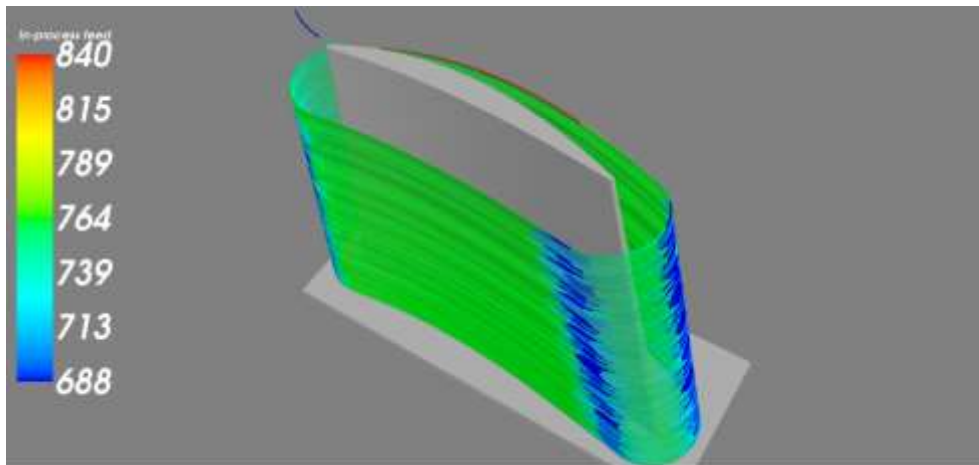

Figure 20: Actual tool path and feed [mm/min] from the machining process.

The handle at second-bottom of the screen makes it possible to zoom in at in-process data, in order to look for more detailed deviations in the process. The user of this visualization program can choose manually if data should be viewed as a whole or only partly through pressing either the button “In-proc path” or “Cut – Path”. Figure 21 uses the latter method to illustrate that the feed changes multiple times around the edge of the blade. The lines are still representing the tool center and not the cutting point. Note that the desired feed value is colored red here, as seen in the legend to the left. The colors only illustrate relative magnitude of the feed, and should not be interpreted as a grade for a good or bad process.

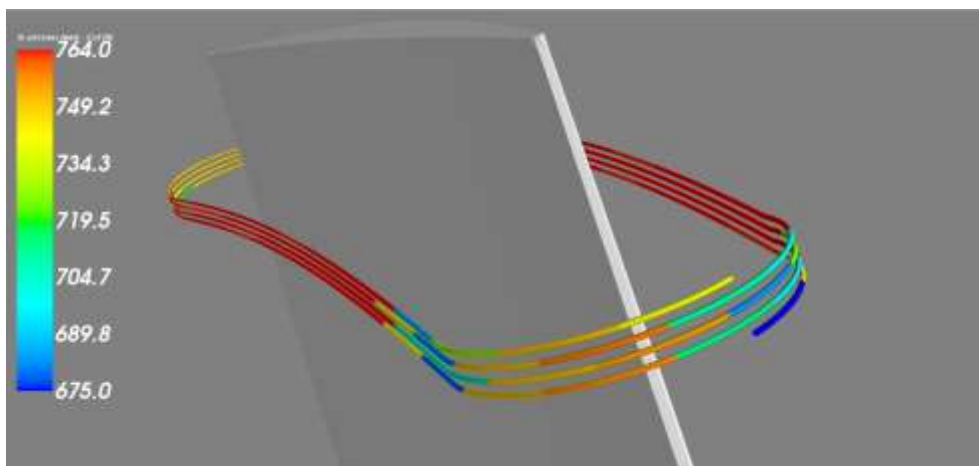

Figure 21: Close up of the tool path and feed [mm/min] from in-process data.

The forces acting on the stationary dynamometer can be shown for the complete blade or as a close up, similar to Figure 20 and Figure 21 respectively. The close up method describes the force tendencies with less noise, and will therefore be the only way the forces are depicted for this section of the report, even though both are available. Figure 22 shows the magnitude and the direction of the forces on a part of the blade. The red arrows indicate that it is a relatively high force, but it does not tell if it is dangerously high.

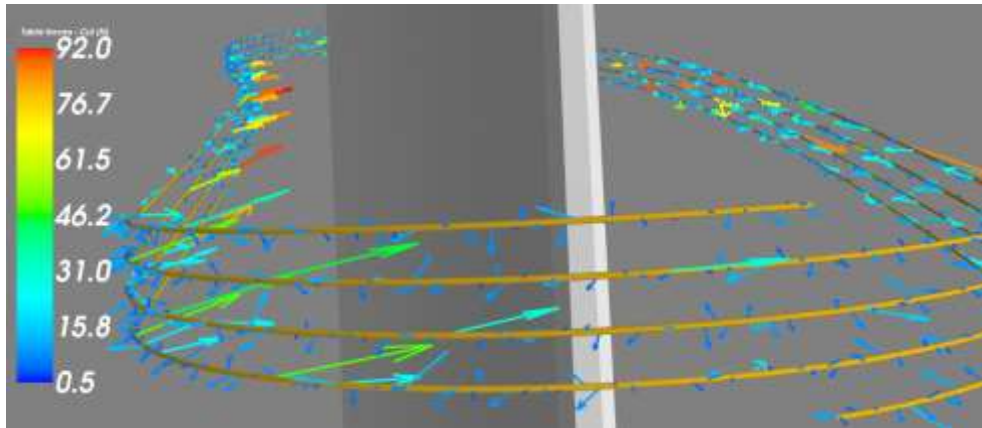

Figure 22: Magnitude and direction of the forces [N] acting on the stationary dynamometer.

The forces on the rotating dynamometer at the tool holder are shown in Figure 23. Since its coordinate system rotates, it is not transformed to the general coordinate system. Instead, the magnitude of the resultant force is shown. The higher cutting forces registered from the stationary dynamometer indicates that the workpiece is exposed to more stress than the cutting tool.

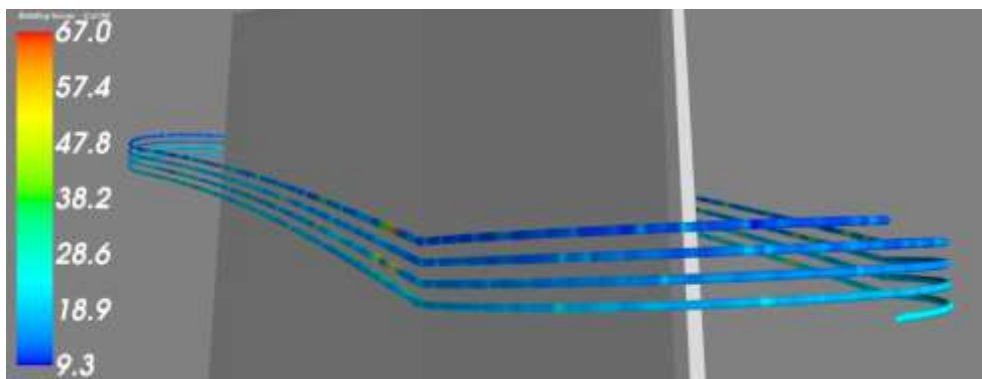

Figure 23: Magnitude of the forces [N] acting on the rotating dynamometer.

The torque at the rotating dynamometer is shown for a section of the machining operation in Figure 24.

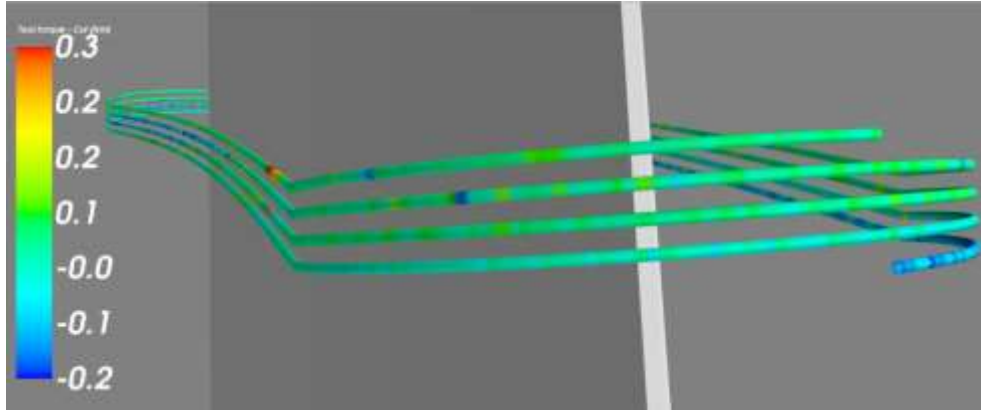

Figure 24: Magnitude of the torque [Nm] acting on the rotating dynamometer.

The vibrations are measured by the accelerometer (m/s) placed at the front of the workpiece, and they are shown for a section of the blade in Figure 25.

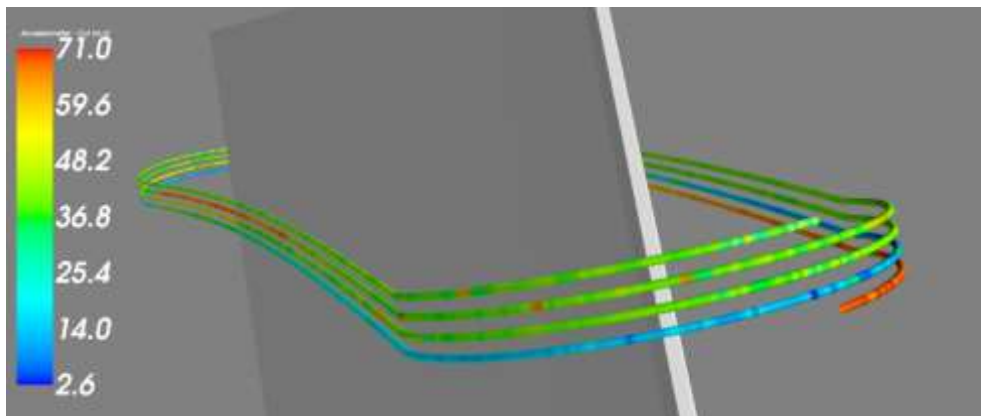

Figure 25: Vibrations measured by the accelerometer in m/s.

Data from the post-process measurements of the component is visualized in Figure 26. The structure of the blade is based on a point cloud from the designed component, with the color value coming from the measured deviation between the nominal and actual model. Negative deviation values indicate that the machining has removed too much at that section. It is possible to toggle the coloring based on tolerances for the application. However, such tolerances are not available for this component, so a conclusion whether this machining process yields a sufficient result is not possible. Actual results after the machining can be shown as in Figure 26. The three spots seen at the top of the component comes from reference stickers used during the measurements. It is possible to interpolate the surface over the holes in order to get a smooth surface.

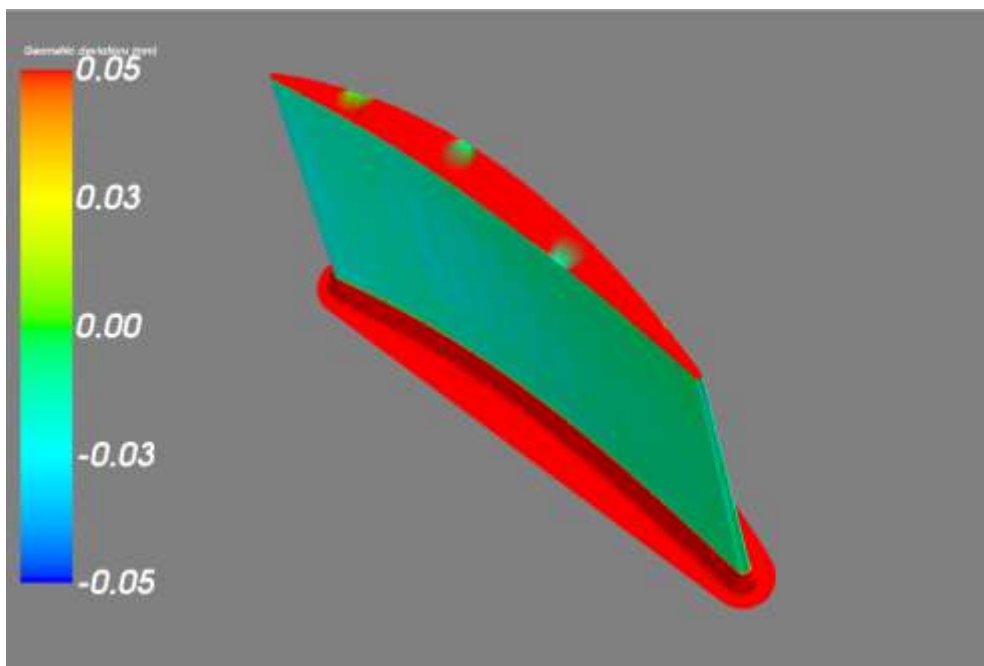

Figure 26: Post-process measurement with graphic representation of the deviation (mm) between the nominal and actual model.

5.2 Results for the case study

In this section some observations made by the visualization software regarding the specific component machined and analyzed. The FTA method is used to align root causes to the observations to identify any root causes for not achieving the required quality.

Figure 27 illustrates the feed variation for a section of blade 1 (top), 2 (middle) and 3 (bottom). The process is programmed to maintain a constant feed, but it drops at the edges of all blades, especially when the nominal feed increases. The in-process tool path does not differ from the CAM generated to the same extent as the feed differs, which indicates that the machine prioritizes the correct positions rather than cutting data. This means the first root cause in the FTA, lack of precision, is avoided since it does not induce dimension problems on the part. The same behavior of feed drop can be seen at the whole blade, see Figure 20.

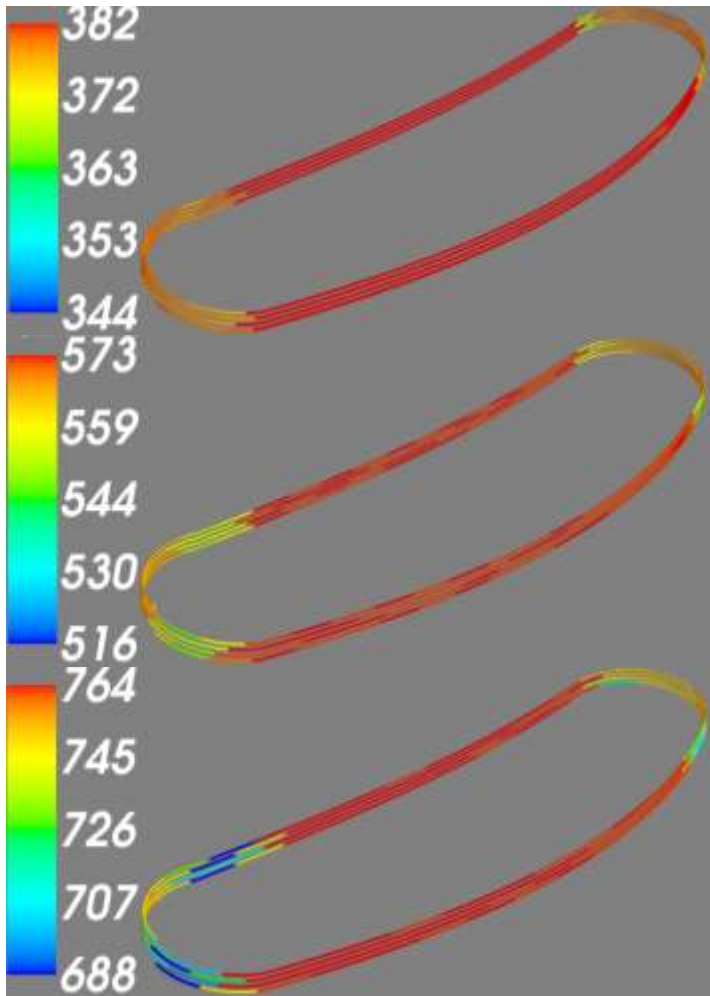

Figure 27: Feed [mm/min] variations for blade 1 (top), 2 (middle) and 3 (bottom) along with legends describing their respective actual feed.

Forces from the stationary dynamometer are shown in Figure 28. The maximum cutting forces are increasing slightly as the feed increases. Medium sized forces occur more often with a higher feed rate. This may cause an increased deflection on either the cutting tool or the workpiece, see root causes 3 and 4 in the FTA, as well as a more rapid tool wear. The highest forces act on the surfaces of the blade because of the increased tool engagement at these sections compared to the edges.

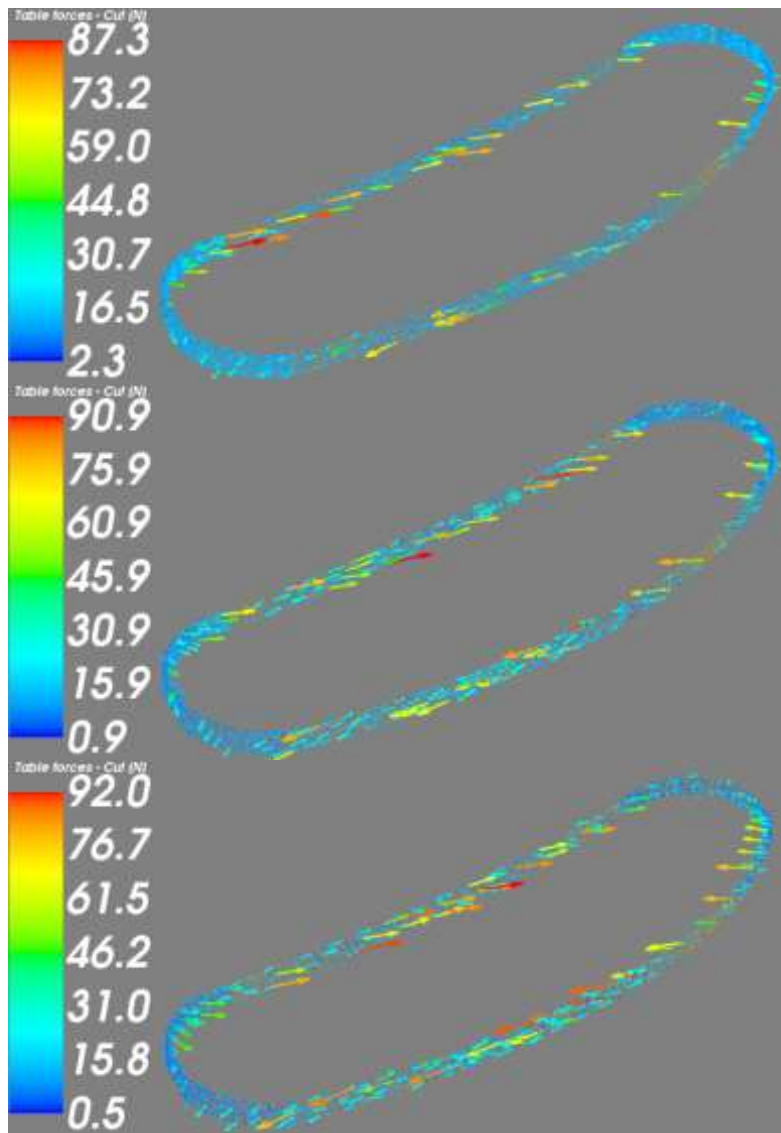

Figure 28: Forces [N] from stationary dynamometer for blade 1 (top), 2 (middle) and 3.

Figure 29 shows forces from the rotating dynamometer for blade 1, 2 and 3 respectively. In theory, the force should increase as the feed increases. This is validated by the cutting forces from the stationary dynamometer. However, force measurements from the rotating dynamometer indicate the mirrored behavior. The first two blades shows mirrored tendencies; the highest forces are generated at the top of blade 1, whilst at the bottom for blade 2. This behavior is unsuspected, and further evaluations of cutting forces from the rotating dynamometer is required.

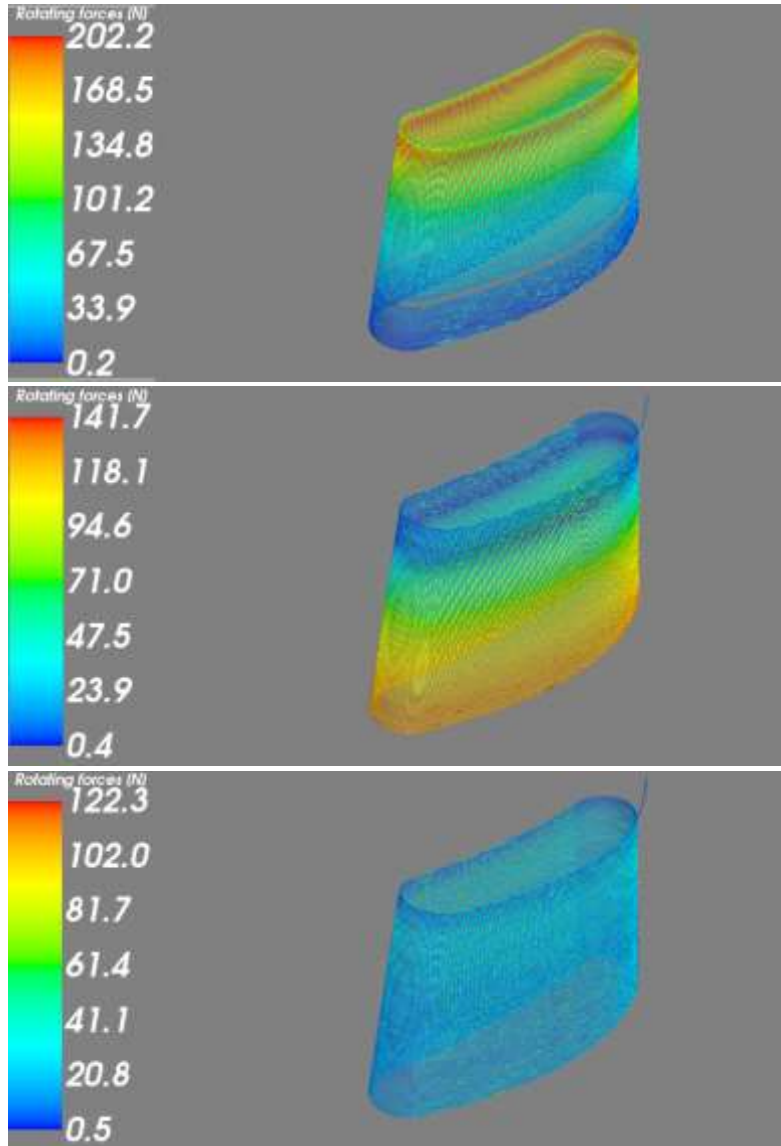

Figure 29: Forces [N] from the rotating dynamometer for blade 1 (top), 2 (middle) and 3.

The maximum torque can be observed to reduce as the feed increases, see Figure 30. It was anticipated to increase with a higher feed. However, the magnitude of the torque is so small that it may be due to measuring inaccuracy at the dynamometer. There are periodical torque peaks over the complete blade. These may be caused by hard inclusions in the workpiece material, either from the raw piece or caused by earlier machining operations.

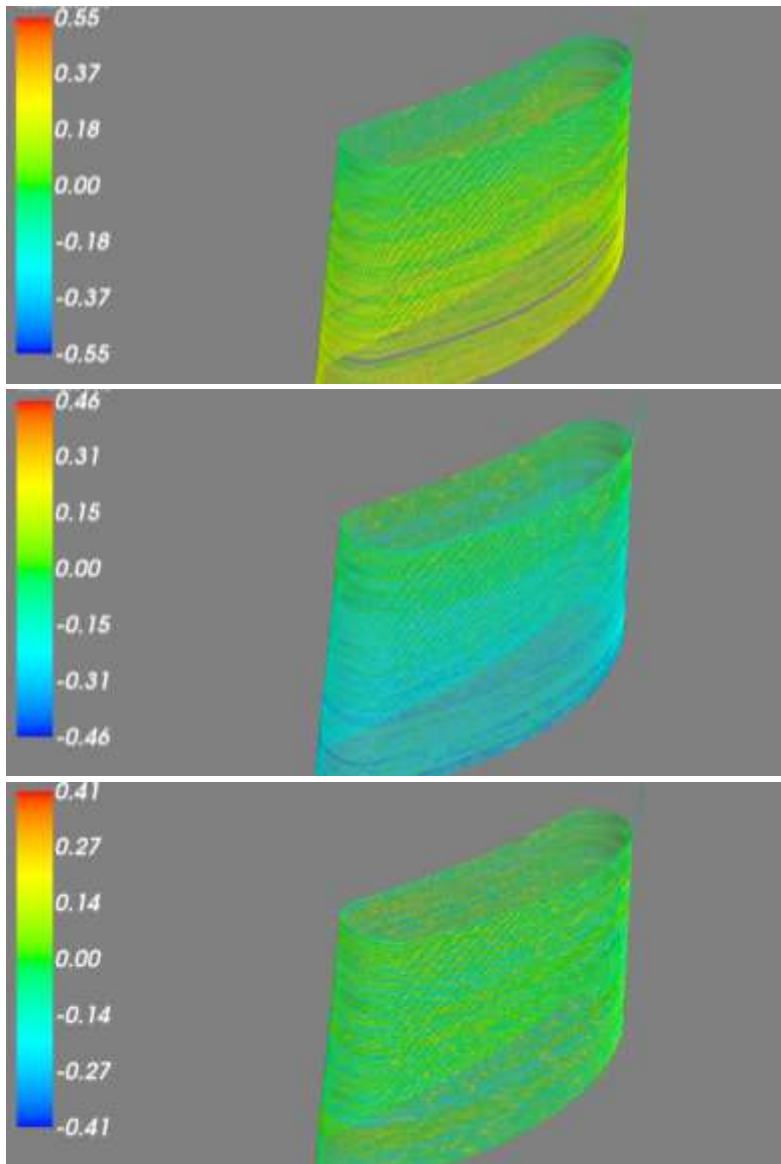

Figure 30: Torque [Nm] at rotating dynamometer for blade 1 (top), 2 (middle) and 3.

Figure 31 visualizes the vibration tendencies for the work piece, root cause 12 in the FTA, for blade 1, 2 and 3 (left) and for the first lap of the machining of the same blades (right). Note that the red sections indicates values of 100 m/s and higher.

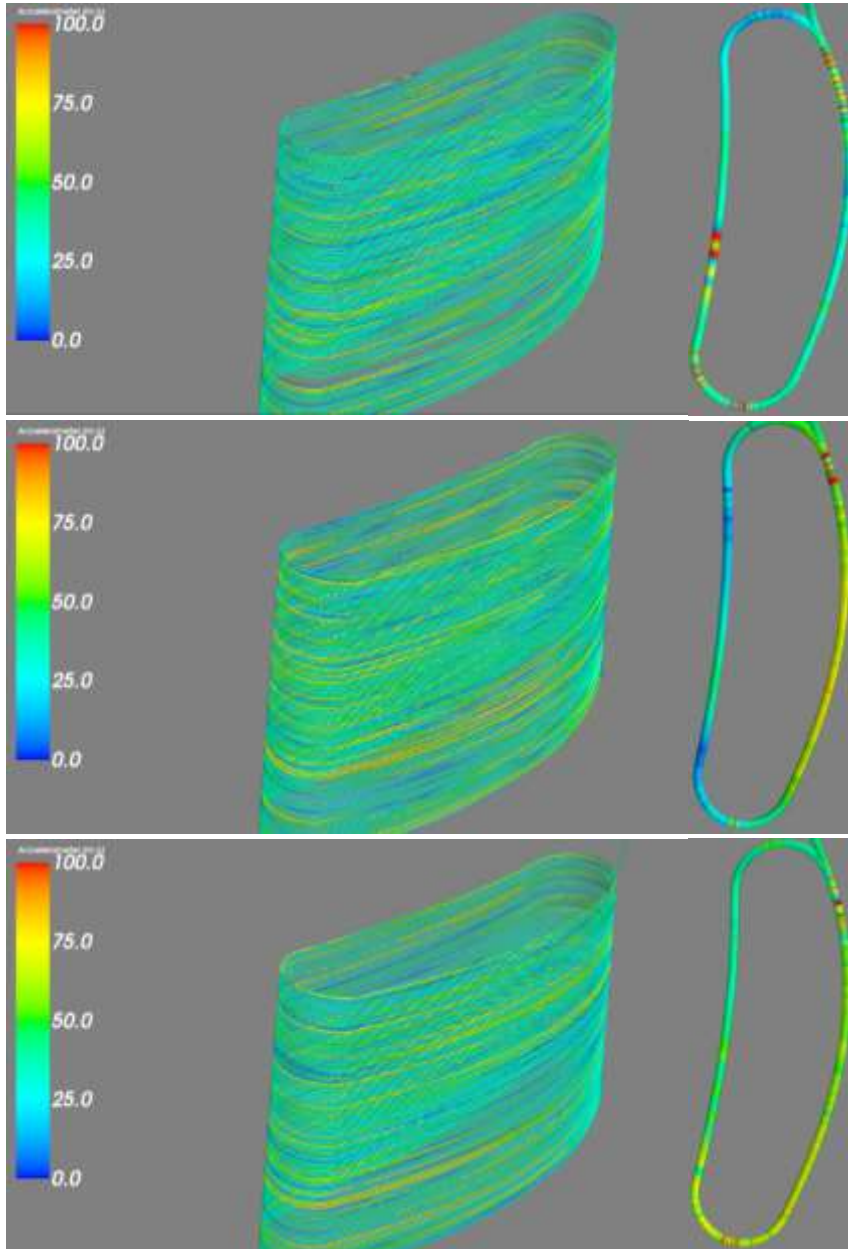

Figure 31: Left hand side shows vibrations [m/s] from accelerometer on blade 1 (top), 2 (middle) and 3. Right hand side shows the first lap of the machining of the same blades.

Actual results after the machining process are visualized in Figure 32, along with the deviations between it and the designed component. It shows that the deviations at the surface of the blade are relatively consistent. This means that the machining process is stable under the current conditions. Note that red and blue sections includes greater deviations as well.

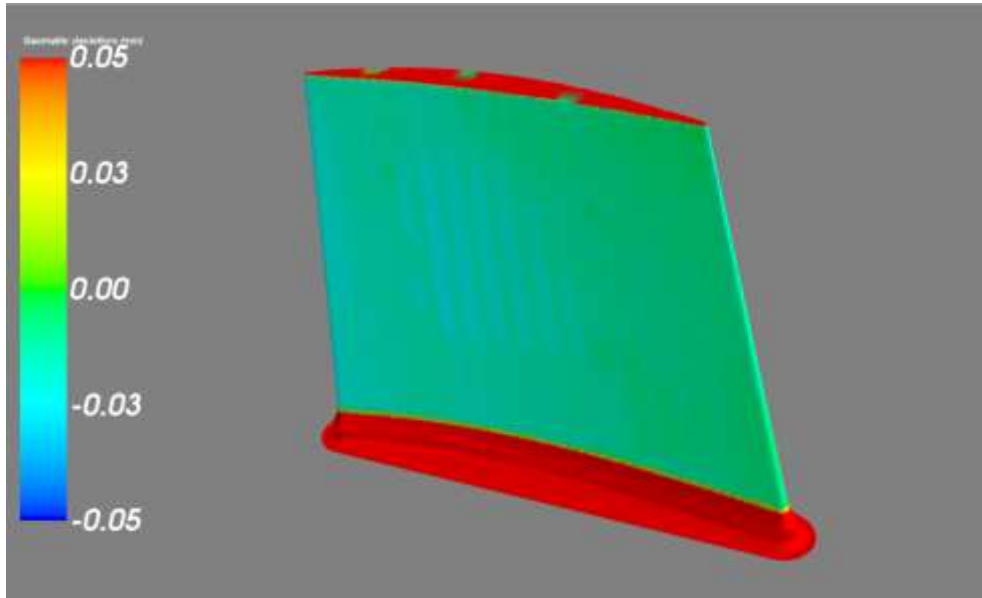

Figure 32: Deviations [mm] between designed blade and actual result.

There are material left at the bottom of the blade due to a misunderstanding during the process planning of the case study. The tool are exposed to increased stresses when its center point is in contact with the material, since the cutting speed at the center is zero, and this should be avoided if possible. Therefore, the bottom area of the blade was not machined in order to minimize the wear on the cutting tool, even though examination of the cutting process behavior at this area would have been of interest. The top of the blade has too much material left, as indicated by the red color in Figure 32. The finishing operation does not machine the top, therefore the error is caused in earlier operations (see root cause number 2 in the FTA).

6 Discussion

Product quality evaluations are of principal interest for future customers, since they are mainly looking at the final result, and not as much at the performance of the machining process. However, this visualization tool may be used by other stakeholders as well. In-process deviations are important to acknowledge for departments working with application development, in order to identify problematic areas. The IFM concept allows comparisons between different machining parameters in an application strategy through relations of data. This enables the possibility to visualize which stage of a machining process that leads to geometric deviations.

Results from three machining processes with varying cutting data are presented in this work, but it is also possible to perform other evaluations. It would be interesting to evaluate the result if the semi-finishing was skipped. If the result is acceptable, the time to produce a component would decrease, and the productivity would increase. This is important for some applications, but not all of them. Another interesting comparison would be to perform exactly the same machining operation, but in a different machine. This would emphasize the importance of choosing the right machine. Other evaluations might be changing the workpiece material, the cutting tools or tool holders. Even the impact of different designs can be illustrated.

The visualization tool illustrates the peaks in cutting forces, torque and vibrations at the cutting path, which is more illustrative than when presented in a table or as a graph. High forces and torque occur more frequently at the surfaces of the blade than at the edges. The edges are thin compared to the cutting tool, which makes a low tool engagement at these sections, and leading to lower cutting forces. Unexpectedly, the feed drops at the edges, especially for the third blade, which is another reason for the decreased cutting forces as compared to the blade surfaces, where the feed is close to the nominal feed at all times. There may also be less material to remove at the edges, which is a third reason for lower forces.

All three blades register the highest vibrations, measured by the accelerometer, at tool entrance. This result illustrates the importance of keeping the tool in constant engagement with the workpiece. Other than that, there are no significant vibration patterns. The accelerometer placement causes it to mainly register vibrations at the base of the workpiece. Had the sensor been attached directly to the blade, it would probably have exhibited both higher frequency and amplitude vibrations at both surfaces or edges.

It is likely that other error sources than just cutting data are involved during the machining process. However, they are not further examined in this work. Different CAM software may prepare a machining process with different algorithms, and it could be of interest to examine how the result would change. Other interesting evaluations could include the connection between CAM software and control system in the machine, and if some control systems handle certain applications better than others. Another error source may be the machine condition, where a worn machine will display less accuracy than when in top condition.

Other machining properties than cutting data could be altered as well. This could include testing of different tool types or grades, as well as diameters. The influence of the tool holder can also be examined. Fixturing devices can be tested to find the optimal design or material for a certain application. Furthermore, it is possible to test different cutting fluids, and how a change in fluid type or pressure affect the machining behavior.

The presented Fault Tree Analysis derives from both theoretical studies and information from the analysis of the case study. Some root causes in the Fault Tree Analysis, such as the influence of feed rates, could be verified through this process, while other factors can be examined in future case studies using this software. The analysis can both be widened to include more cause and effect relationships, but also validate the interconnected relations.

This demonstrator is developed for 3 axis machining of a blade. However, it is possible to develop it further in order to visualize other machine configurations. The tool is always vertical in this application, but it will be rotated in 4 or 5 axis milling. This means that data for tool angle at each position need to be acquired as well.

7 Conclusions

7.1 Conclusions

This work shows that it is possible to develop a tool for visual supervision of, and acquiring feedback from, manufacturing operations through connecting data from pre-process, in-process and post-process. All data is related to the component, in order to achieve a quick and clear relation between the data sets. The tool is able to analyze machining processes and show tendencies and problems of operations. Through executing several machining tests with slightly modified attributes, it is possible to find a preferable method for a certain application. Such attributes may be cutting parameters, CAM software or machining order.

An analysis is performed, where the cutting data is altered. This indicates that the control system has trouble to maintain the correct feed if the nominal feed is too high. Cutting forces increases as the feed increases, and they are higher at the surfaces of a blade than at the edges, since the tool engagement is greater at the surfaces. However, this does not seem to have any negative influence on the result of the blade, which indicates that the cutting forces are relatively low. The workpiece tend to vibrate the most at tool entrance, so constant tool engagement is important.

7.2 Future work

This program visualizes data from one machining application. It can handle changes in the pre-process methods, as well as new in-process and post-process measurements. However, the software needs to be developed further in order to be able to visualize data from machining applications with more than three axes. The in-process data are visualized at the tool center. However, it may be more descriptive to illustrate it on the machined surfaces. The surface for the deviations in the post-process data could be smoother, which possibly can be obtained with other triangulation methods in the future.

7 References

- [1] Sandvik AB, "Annual Report 2014," 2015. [Online]. Available: https://www.sandvik.com/globalassets/sandvik_ar_2014_engprintedversion.pdf. [Accessed 16 09 2015].
- [2] Sandvik AB, "History," 2015. [Online]. Available: <http://www.sandvik.com/en/about-us/our-company/history/>. [Accessed 16 09 2015].
- [3] Sandvik AB, "Sandvik's Business Areas," 2015. [Online]. Available: <http://www.sandvik.com/en/about-us/our-company/business-areas/>. [Accessed 16 09 2015].
- [4] Sandvik Coromant, "Sandvik Coromant in brief," 2015. [Online]. Available: http://www.sandvik.coromant.com/en-us/aboutus/sandvik_coromant_in_brief/pages/default.aspx. [Accessed 16 09 2015].
- [5] Sandvik Coromant, "About us," 2015. [Online]. Available: <http://www.sandvik.coromant.com/en-us/aboutus/lookingahead/pages/an-outlook-into-the-future-of-manufacturing.aspx>. [Accessed 16 09 2015].
- [6] Sandvik Coromant, "Aerospace," [Online]. Available: <http://www.sandvik.coromant.com/en-gb/industrysolutions/aerospace/titanium/Pages/Blisk.aspx>. [Accessed 26 01 2016].
- [7] M. Höst, B. Regnell and P. Runeson, Att genomföra examensarbete, Lund: Studentlitteratur, 2006.
- [8] J.-E. Ståhl, Industriella tillverkningssystem: Del I - Material och tillverkningsmetoder, 2 ed., Lund, 2012.
- [9] J.-E. Ståhl, Metal Cutting - Theories and models, Lund, 2012.
- [10] Sandvik Coromant, "The Milling Process," [Online]. Available: <http://www.sandvik.coromant.com/en->

us/knowledge/milling/formulas_and_definitions/the_milling_process/pages/default.aspx. [Accessed 26 01 2016].

- [11] Sandvik Coromant, "Knowledge," 2016. [Online]. Available: http://www.sandvik.coromant.com/en-gb/knowledge/milling/formulas_and_definitions/formulas/pages/default.aspx. [Accessed 12 01 2016].
- [12] M. Helgason and V. Kalhori, "A Conceptual Model for Knowledge Integration in Process Planning," *Procedia CIRP*, vol. 3, pp. 573-578, 2012.
- [13] ISO, "Standards Catalogue," 2015. [Online]. Available: http://www.iso.org/iso/home/store/catalogue_tc/catalogue_detail.htm?number=57620. [Accessed 14 12 2015].
- [14] C. R. Gilman and S. J. Rock, "The Use of STEP to Integrate Design and Solid Freeform Fabrication," pp. 213-220, 1995.
- [15] J. Bibee, "Understanding Optical Measurement," *Quality Digest*, 31 03 2009.
- [16] T. Brajliah, T. Tasic, I. Drstvensek, B. Valentan, M. Hadzistevic, V. Pogacar, J. Balic and B. Acko, "Possibilities of Using Three-Dimensional Optical Scanning in Complex Geometrical Inspection," *Journal of Mechanical Engineering*, vol. 57, no. 11, pp. 826-833, 2011.
- [17] M. Helgason, P. Eriksson and A. Ivarsson, "Technological Prototype - Integrated Feature based Metrology," Sandvik, Sandviken, 2006.
- [18] P. L. Clemens, "Fault Tree Analysis," Jacobs Sverdrup, 1993.
- [19] DMG Mori Seiki, "DMG Mori Products," 31 01 2014. [Online]. Available: <http://us.dmgmori.com/blob/165762/8ea6234b0daddf63e9d67b746f25638f/pm0uk13-nv5000-pdf-data.pdf>. [Accessed 19 01 2016].
- [20] Sandvik Coromant, "Tools," 2016. [Online]. Available: <http://www.sandvik.coromant.com/en-gb/products/pages/productdetails.aspx?c=R216.24-16050CCC32P%201620>. [Accessed 13 01 2016].
- [21] Sandvik Coromant, "Tools," 2016. [Online]. Available: <http://www.sandvik.coromant.com/en->

gb/products/pages/productdetails.aspx?c=R216.44-10030-AK22N%201620.
[Accessed 13 01 2016].

- [22] Kistler, "Cutting Force Measurement," 2009. [Online]. Available: <http://www.m3.tuc.gr/EQUIPMENT/MIKRODYNAMOMETRO/cutting%20force%20measurement.pdf>. [Accessed 15 01 2016].
- [23] Kistler Holding AG, "Cutting Force Measurement," 2012. [Online]. Available: http://www.kistler.com/se/en/applications/sensor-technology/cutting-force-measurement/milling/products/#multi_component_dynamometer_up_to_60_k_n_9255_c. [Accessed 19 01 2016].
- [24] Kistler Group, "Rotating 4-Component Dynamometer RCD," 2008. [Online]. Available: <http://www.kistler.com/?type=669&fid=3344>. [Accessed 19 01 2016].
- [25] GOM, "Metrology Systems," [Online]. Available: <http://www.gom.com/metrology-systems/system-overview/atos-triple-scan.html>. [Accessed 19 01 2016].

8 Appendix

Appendix – Fault Tree Analysis

