

Student thesis series INES nr 383

# **Assessing avalanche risk by terrain analysis**

## **An experimental GIS-approach to The Avalanche Terrain Exposure Scale (ATES)**

**Simon Nåfält**

---

2016  
Department of  
Physical Geography and Ecosystem Science  
Lund University  
Sölvegatan 12  
S-223 62 Lund  
Sweden



Simon Nåfält (2016).

*Assessing avalanche risk by terrain analysis – An experimental GIS-approach to The Avalanche Terrain Exposure Scale (ATES)*

*Uppskattning av lavinrisk genom terränganalys – En experimentiell GIS-strategi för The Avalanche Terrain Exposure Scale (ATES)*

Bachelor degree thesis, 15 credits in *Physical Geography and Ecosystem Science*

Department of Physical Geography and Ecosystem Science, Lund University

Level: Bachelor of Science (BSc)

Course duration: *March* 2016 until *June* 2016

#### Disclaimer

This document describes work undertaken as part of a program of study at the University of Lund. All views and opinions expressed herein remain the sole responsibility of the author, and do not necessarily represent those of the institute.

# **Assessing avalanche risk by terrain analysis**

**An experimental GIS-approach to The Avalanche Terrain Exposure Scale (ATES)**

---

**Simon Nåfält**

Bachelor thesis, 15 credits, in *Physical Geography and Ecosystem Science*

Supervisor: Andreas Persson  
GIS-Centrum  
Lund University

Examiner: Ulrik Mårtensson,  
Department of Physical Geography and Ecosystem Science  
Lund University



## **Abstract**

This study addresses the complex nature of snow avalanches and how their location can be predicted, and thus avoided, when navigating through mountainous terrain during winter recreations. The avalanche risk in the ski area of Nuolja, in northern Sweden, was evaluated by an experimental implementation of the Avalanche Terrain Exposure Scale (ATES) which is a model for pre-trip planning and assessment of exposure to avalanches. The model includes a high level of subjectivity and thus requires some background knowledge in avalanche science. The parameters in ATES consider terrain characteristics and avalanche history to determine the exposure. Analysis was carried out by the use of GIS software which is a departure from the intended usage method. The model was implemented two times: Firstly, according to the original model and, secondly, through modifying ATES by including an altitude parameter which is a terrain factor that is not included in the original model. The results indicated that the highest exposure mainly resides in areas that have experienced avalanches in the past. Including altitude did not show any clear improvements, mainly due to difficulties in evaluating the results from a model that already includes the “ground truth”, which in this case were previous avalanches. It was concluded that ATES can be a valuable tool for avalanche prediction but the current model is not very well suited for GIS. Furthermore, the subjectivity in the model makes the results highly dependent on the producer.

Key words: Avalanche, Terrain analysis, ATES, Altitude, GIS, Nuolja

## **Sammanfattning**

Denna studie behandlar den komplexa karaktären hos snölaviner och hur de kan förutsägas, och därmed undvikas, vid navigering genom fjällterräng under vinteraktiviteter. Risken för laviner i skidområdet Nuolja, i norra Sverige, utvärderades genom en experimentell tillämpning av The Avalanche Terrain Exposure Scale (ATES) som är en modell utvecklad för planering och bedömning av lavinexponering. Modellen innehåller en hög grad subjektivitet och kräver därför en viss bakgrundskunskap inom lavinämnet. Parametrarna i ATES behandlar terrängen och lavinhistoria för att bestämma exponeringen. Analysen utfördes med hjälp av GIS-programvara vilket är en avvikelse från den avsedda användningsmetoden. Modellen genomfördes två gånger: först enligt den ursprungliga modellen och sen även genom en modifiering av ATES med hjälp av att inkludera en höjdparameter, vilket är en terrängfaktor som inte ingår i den ursprungliga modellen. Resultaten visade att den högsta exponeringen huvudsakligen förekommer i områden som har utsatts laviner förut. Inkluderingen av höjdparametern visade inte några tydliga förbättringar, främst på grund av svårigheterna att utvärdera resultaten från en modell som redan omfattar utvärderingsdata, som i det här fallet var historiska laviner. Det konstaterades att ATES kan vara ett värdefullt verktyg för att förutsäga lavinriskområden, men den nuvarande modellen är inte väl lämpad för GIS. Vidare gör subjektiviteten i modellen att resultaten i hög grad beroende på användaren.

Nyckelord: Laviner, Terränganalys, ATES, Höjdparameter, GIS, Nuolja

## **Acknowledgement**

I would like to thank my supervisor Andreas Persson for all the guidance and feedback throughout the course. I would also like to thank STF Abisko for providing data on documented avalanches in Nuolja.

## Contents

<b>1. Introduction</b> .....	2
1.1 Aim.....	2
1.2 Assumptions and Limitations .....	3
<b>2. Background and Theory</b> .....	4
2.1 Avalanches .....	4
2.2 The formation of an avalanche .....	5
2.2.1 Meteorological factors .....	5
2.2.2 Snowpack factors .....	6
2.2.3 Terrain Factors .....	6
2.3 Value and methods of Avalanche forecasting .....	7
2.4 The Avalanche Terrain Exposure Scale .....	8
2.5 Study Area.....	10
<b>3. Method</b> .....	11
3.1 Data .....	11
3.2 Implementing the Avalanche Terrain Exposure Scale .....	11
3.2.1 Slope inclination .....	12
3.2.2 Aspect .....	12
3.2.3 Slope shape .....	13
3.2.4 Terrain traps .....	13
3.2.5 Forest/Vegetation cover .....	14
3.2.6 Avalanche frequency .....	14
3.2.7 Start zone, track, runout zone and path .....	14
3.2.8 Glaciation and route options .....	15
3.3 Development of ATES map .....	15
3.4 Integrating altitude in ATES .....	15
3.5 Analysing the results .....	16
3.6 Generalizing the results .....	16
<b>4. Results</b> .....	17
4.1 Original ATES parameters .....	17
4.2 Integrating Altitude in ATES .....	18
4.3 Analysing the results .....	19
4.4 Generalized results .....	20
<b>5. Discussion</b> .....	21
5.1 Data .....	21
5.2 Implementation of ATES in GIS.....	21
5.3 Results .....	23
5.4 Further studies .....	24
<b>6. Conclusion</b> .....	25
<b>7. References</b> .....	26
<b>8. Appendices</b> .....	29



## 1. Introduction

Avalanches are snow masses, driven by gravity, moving rapidly down mountain slopes. Each winter there is a considerable amount of both triggered avalanches and potential avalanche risk areas in the Swedish mountains. Around one million individuals reside in these areas each winter. Since the beginning of the 21st century, 9 people have died in avalanche accidents in the Swedish mountains (SMHI 2014). In the future, this number might increase due to the growing interest in off-pist skiing, off road snowmobile usage and a general increase in tourism (Naturvårdsverket 2014a).

Varying climatic conditions during winter and spring leads to stratification in the snowpack where the snow layers have different mechanical properties such as cohesion and shear strength. This structure makes the snowpack susceptible to internal slides between the layers. The stability of the snow cover depends on many different factors that can be divided into fixed (e.g. slope and aspect) and varying factors (e.g. wind and precipitation)(Ancey 2001). According to Mcclung and Schaerer (2006), snowpack instability evaluation “involves aspects of both science and art” and that there is no precise equations available. Furthermore, it is explained how field observations and experience are crucial.

The exceedingly complex nature of avalanches has led to the development of several predictive models with different approaches (Ancey 2001). Predictive models are favourable for detection of instability that is a direct result of weather changes over large areas. For a specific backcountry avalanche hazard analysis however, it is crucial to investigate the terrain (Mcclung and Schaerer 2006).

Parks Canada has developed the Avalanche Terrain Exposure Scale (ATES) which is a method of evaluating avalanche risk based on the terrain and past avalanches. The end product of the model leads to a categorization of the terrain into simple, challenging and complex exposure to avalanches. The initial goal with this method was to create a system for “pre-trip” planning, or to get an overview of the terrain, in contrast to “in-slope” decision making that backcountry visitors might encounter. A fundamental parameter of the terrain, aspect, is excluded in ATES since it is deemed irrelevant to larger scale applications the method originally was intended for. Aspect should however be considered on a slope scale (Statham et al. 2007). The 11 parameters that are treated in ATES include a high degree of subjectivity, with its frequent use of terms like *mostly*, *generally* and *primarily* when describing how parameters should be managed (Campell et al. 2012). The developers (Statham et al. 2007) describe how the next logical step would be to present ATES as polygons directly on terrain maps, instead of text in columns, which improves the way of presenting avalanche exposure to the public. Furthermore, according to Statham et al. (2007), attempts of doing this by implementing geographical information system (GIS) are in development. Large scale ATES-analysis has been carried out in avalanche risk areas in Sweden that are commonly visited by skiers and snowmobile users (Fjällsakerhetsrådet 2015). In this study, an attempt will be done to make an ATES analysis of the Swedish off-pist mountain of Nuolja, with the use of GIS software.

### 1.1 Aim

The avalanche risk areas in Nuolja will be assessed through:

- Implementation of high resolution, slope-scale, ATES analysis to classify the off-pist areas in Nuolja, Sweden
- Comparison between ATES with and without altitude
- Method development for including altitude in ATES

## **1.2 Assumptions and Limitations**

The lack of field experience, other than a general description of locations of past avalanches, creates difficulties implementing ATES accurately. Also, the high subjectivity is not well suited for a GIS-system that implements mathematical algorithms which need a quantitative input. The method tested in this study is also relatively new (2006) and amount literature about implementing GIS in the analysis is low. With this in mind, this study has to be considered an experimental ATES-analysis of avalanche exposure in Nuolja.

## 2. Background and Theory

### 2.1 Avalanches

The area in which avalanches move is called an avalanche path. This can then be divided in to start zone, track and runout zone. The start one is the upper part of the path where avalanches initiate, or are “triggered”. The avalanches then run along the track, until they reach the runout zones that are the lower area where the snow deposits and the avalanche stop. The general inclination angle for runout zones are  $10^\circ$  when looking at it statistically worldwide. The length of an avalanche path may vary between less than 50 meters to several thousand meters depending on avalanche size (Ancy 2001; Mcclung and Schaerer 2006).

The release of an avalanche can occur as two different types, loose snow release or slab release. These two can further be divided into wet or dry avalanches. The loose snow avalanches start in a point or area near the surface of a snow cover with little or no cohesion. From this point it then spreads out in a triangular pattern as snow beneath the starting point is integrated into motion. The cause for the initiation of a loose snow avalanche is that the critical angle of static friction is exceeded by the slope angle. The slab avalanche is a result from a collapse of a deep weak layer in the snowpack when the shear strength is exceeded by the shear stress, thus, leading to a fracture in the aloft cohesive layer and the dislodge of a unit of snow, a slab, that slide down the slope (Schweizer 1999)(Figure 1). The majority of dry slab avalanche release is due to high amounts of new snow that induce stress on a weak underlying snow layer by loading (Mcclung and Schaerer 2006).

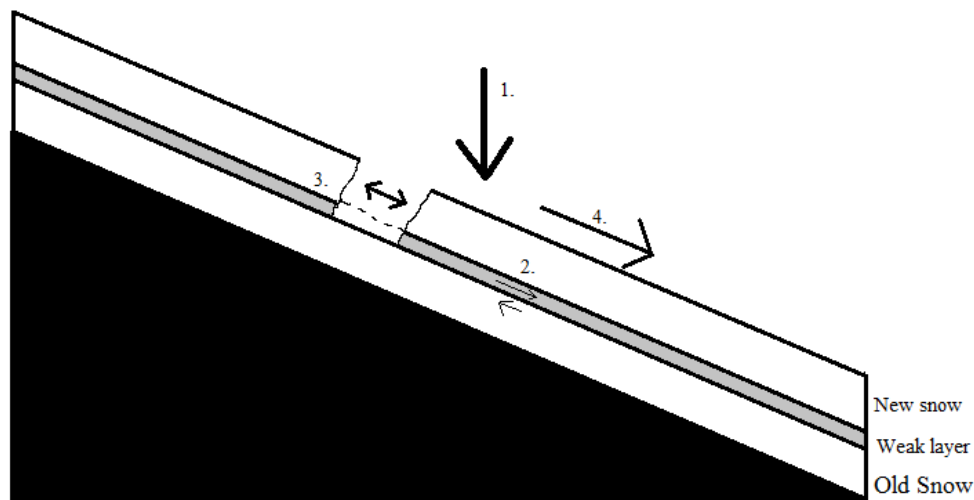

**Figure 1: Slab avalanche release.** 1: Shear stress on snow pack, 2: Weak layer collapse, 3: Fracture in upper snow cover, 4: Slab that slide down the slope. Modified from Sjölander (2004).

An increase in the liquid water content in the snow leads to reduced shear strength and thus increased avalanche activity (Ancy 2001). Wet avalanche occurrence is still not well understood leading to challenges in predicting them (Baggi and Schweizer 2009). The dry-slab avalanche is the most hazardous for backcountry activities and is responsible for most accidents both in Sweden and internationally, thus it is the most studied type (Göransson et al. 1984; Mcclung and Schaerer 2006), and also the main focus in this study.

The triggering of an avalanche can be divided into *natural* and *artificial* release where the artificial is caused by humans, e.g. explosives or skiing (Mcclung and Schaerer 2006). The majority of avalanches release naturally during or shortly after storm events. However,

most avalanche victims are skiers that trigger the avalanche themselves where the snowpack is too weak to support the additional pressure applied by the skier (Schweizer 1999).

## **2.2 The formation of an avalanche**

The complex interaction between meteorological conditions, terrain and snowpack are the basis of formation of weak deficit zones that could result in an avalanche (Schweizer 1999; Schweizer et al. 2003). According to Schweizer et al. (2003), there are a lot of uncertainties of where and when an avalanche will occur and there are no definite answers about all the involved processes given by current science. However, Schweizer et al. (2003) describes five essential factors for predicting avalanche occurrence; terrain, precipitation, temperature, wind and snowpack stratigraphy.

### **2.2.1 Meteorological factors**

#### Precipitation

Precipitation is mainly considering new snow deposition which is the most frequent cause of avalanches. This is due to the new additional weight influencing the balance between shear stress on any weak layer's shear strength, leading to an increased risk for slab avalanche (McClung and Schaerer 2006). The intensity of the precipitation is also important to study since the weight of the new snow is slowly compressing the weak layer and increasing its stability. Therefore there is a competition between loading rate and stabilization rate (Schweizer et al. 2003). Another thing to consider with the precipitation of new snow is its density. The density can be an indicator of how the snowpack stratigraphy will develop. For slab formation the optimal density on the new snow is between 100 and 250 kg/m<sup>3</sup>, but they can also occur outside this density range (McClung and Schaerer 2006).

#### Wind

The way wind affect avalanche formation is through its impact on snow deposition. Prevailing wind direction in combination with snow precipitation is a way of finding favourable sites for avalanche release. Irregular deposition of snow (leading to locally high loading rate) and a higher amount of snow in general are common on the leeward sides of a mountain or a ridge (Schweizer et al. 2003). An example of this is the cornice, which is an accumulation of snow on the leeward side of a ridge, which can collapse and form an avalanche (National Avalanche Center). High wind speeds can also lead to wind packing of the snow on the windward side which can result in slab formation depending on the type of snow precipitation. If there is high winds without snow precipitation, winds might instead export weak surface layers from the windward side to rid the snowpack of future exposure to avalanches (McClung and Schaerer 2006). The wind direction can also change on several scales due to local temperature gradients or terrain features, which has to be considered (Schweizer et al. 2008).

#### Temperature

The main influence of on avalanche occurrence is snow metamorphism in which the temperature gradient plays a vital role (Logan 1992; McClung 1996). The formation of bonds in the snow occurs both by molecular motion on crystal surfaces between neighbouring grains and by diffusion of water vapour through porosities in the snow. This process is called sintering (McClung and Schaerer 2006). Cold temperatures can lead to weakness in the snow due to slow sintering, while warmer temperatures enhance the sintering (Osborn 1982). Due to the low thermal conductivity of snow, these processes mainly affect the surface layer (Sturm et al. 1997).

The most important thing to study when making temperature observations is the trend, or the rate of change. Rising temperature during heavy snowfall can lead to cohesive layers of

snow on top of weaker layers (that was deposited during colder temperatures) which creates suitable conditions for slab avalanches (Schweizer et al. 2003; Mcclung and Schaerer 2006).

### **2.2.2 Snowpack factors**

Snowpack instability is the result of successive snowfalls and varying climatic conditions leading to stratigraphy and thus susceptibility to slides between the layers (Ancey 2001). Weak layers are most commonly formed at the snow surface and are then subsequently covered with new snow (Colbeck and Jamieson 2001). There are several drivers behind this stratigraphy and spatial variability in the snow pack, such as radiation and wind (Schweizer et al. 2008). The snowpack characteristics are mainly determined by the mechanical properties to withstand applied pressure, the shear strength. The physical properties of a snowpack that determine the shear strength includes, among others, density, temperature and bonding to adjacent layers. Generalizing, the two components of shear strength are friction and cohesion in the snow.

The cohesion is the bond strength of neighbouring crystals and grains in the snow which is dependent on grain shape, grain size and density of bonds. Some examples of development of low cohesion snow layers are: *i*) during snowfalls with cold temperatures and relatively windless conditions, *ii*) when snow crystals have rounded or faceted shapes that stagnate bond formation or *iii*) when the snow becomes wet, leading to melting of bonds.

Friction is the resistance to movement between grains in one layer and grains in a neighbouring layer, which is important in slab avalanche formation. Snow friction foremost depend on water content, texture and weight of snow layers above. Therefore friction increase with snow depth (Mcclung and Schaerer 2006).

### **2.2.3 Terrain Factors**

Terrain is the only avalanche factor that is constant with time (Schweizer et al. 2003). Avalanches can occur on any slope with certain topographic characteristics, with the exception of slopes occupied by dense forest that function as anchors, holding the snowpack in place (Schneebeli et al. 1999; Maggioni and Gruber 2003; Mcclung and Schaerer 2006). According to BC NRS (2011), the forest density need to prevent avalanches is 1000 trees per hectare.

#### Inclination

For triggering of an avalanche, the slope inclination generally have to be in the range of 25° to 55° (Mcclung and Schaerer 2006). The majority of dry slab avalanches occur when the slope is >30° (Fjällsakerhetsrådet) and the typical value is 38° (Perla 1977; Schweizer 1999). For slopes inclining less than 25°, the shear stress and shear deformation is not sufficient enough to cause fractions and failures in the snowpack. For inclinations >55°, natural release of sluffs (loose-snow avalanches) prevents slab formation (Mcclung and Schaerer 2006). Slope inclination is one of, if not the most influencing parameter in avalanche occurrence (Maggioni and Gruber 2003; Haegeli and Schweizer 2015).

#### Aspect

The direction of a slope, aspect, is another terrain parameter. With aspect, the snow cover will vary in characteristics due to different exposure to wind and sun radiation (Mcclung and Schaerer 2006). In winter times, north aspect slopes (on the northern hemisphere) receive little direct heat from the sun and lose heat due to long wave radiation, leading to slow stabilization and a tendency to form weak layers. On the same time the melting during the day and freezing during the night, in the south aspect slopes, increase stability in the snowpack.

During spring, the snowpack in the north aspect slopes might instead be more stable since it is stabilizing at a steady rate with the air temperature increase and is shielded from the sun. The sun exposed south aspect slopes might instead experience instability due to rapid melting, leading to wet slab avalanches (Conway and Raymond 1993; Mcclung and Schaerer 2006). The orientation to prevailing wind can also change snow pack properties (see section 2.2.3) (Mcclung and Schaerer 2006). Statistics show that most avalanche accident occurs in north facing slopes. However, this is not based on slope usage which has to be considered (Mcclung and Schaerer 2006).

### Altitude

The meteorological conditions of temperature, wind and precipitation, explained in section 2.2.1, are more suitable for avalanche formation at higher altitudes where temperature is lower, wind speeds higher and precipitation amount increased. According to Gleason (1994), altitude have a highly significant relationship to avalanche start zone frequency. The variations in snow cover properties with altitude can also lead to varying stability in the upper and lower parts of a mountain side, potentially posing a problem assessing avalanche risk for backcountry activities. (Mcclung and Schaerer 2006).

### Surface Roughness

Rough terrain surfaces will act as anchors to the snowpack and hold it in place. Some examples of this are boulders, trees and terrain terraces. The size and density of the anchors in proportion to the snow has to be considered however. If there is a sufficient snow depth, the anchors will become irrelevant to the large scale snowpack. The density of the surface roughness can affect avalanche frequency in two ways. High density of e.g. a forest will be an efficient anchor. Wide-spread trees or boulders, that penetrate the snowpack, might instead pose a weakness (Logan 1992; Ancy 2001; Mcclung and Schaerer 2006).

### Slope shape

By examining the slope shape it is possible to further analyse avalanche occurrence. With convex slope, there is a tension in the snowpack that can cause shear fracture weakness and thus avalanche activity (Foehn et al. 2002; Mcclung and Schaerer 2006). In concave slopes there is instead compression of the snowpack that can prevent smaller slab avalanches (National Avalanche Center). Looking at a slope in a transverse direction profile, convexity and concavity can influence how snow is deposited (Luckman 1978). Locally high amounts of new snow increase weight on underlying snow and thus increase risk of avalanches.

## **2.3 Value and methods of Avalanche forecasting**

Most off-pist skiing is done in near proximity to ski areas without requirement of considerable experience. In recent years however, the “top touring”, or skiing in unknown areas where you can’t get by ski lifts, has increased among Swedish skiers (Naturvårdsverket 2014b). Avalanche warnings are usually issued by local avalanche centres that monitor weather and study the snowpack stratigraphy in the area to determine risk level and general topographic terrain features to avoid. Avalanche risk in Sweden is reported according to the North American Danger Scale which has five levels of avalanche risk from *Low* to *Extreme* and considers both likelihood of avalanche triggering and presumed size of avalanches (Appendix 2). In ski areas this can then be combined with local knowledge about where avalanches are frequent to implement preventive measures and reduce the risk of accidents.

The most effective way to predict future avalanches is to look at the historical events (Perla and Martinelli 1976). A slope with history of avalanching is likely to experience more in the future. Avalanche dynamics include aspects of fluid-, particle- and soil mechanics,

making it very difficult to model. It is also hard to calibrate and improve models due to difficulties in collecting data from real avalanche events. This has led to the development of several different computational models that attempt to describe and predict avalanches with different approaches (Harbitz et al. 1999). There is no worldwide acknowledged model standard available that describes all avalanches adequately and, according to Harbitz et al. (1999), there probably never will be. Among all methods of predicting avalanches, the most used types are statistical- and dynamical models (Ancey 2001).

Statistical models are a way to estimate avalanche zones or their extent. A common model for this is the Norwegian statistical-topographical  $\alpha$ - $\beta$  model, developed by Lied and Bakkehoi (1980). This has been extensively used for avalanche mapping and land use planning. All statistical models rely on correlations between topography and runout distance, and need high resolution input data of profiles in historical avalanches (Harbitz et al. 1999; Barbolini et al. 2000; Ancey 2001).

Dynamical models attempt to describe the fluid like motions of avalanches mathematically (Barbolini et al. 2000). One of the most widely used dynamic model is the Savage-Hutter model, developed by Savage and Hutter (1991). This is designed to model avalanche motion and deformation from start zone to runout zone, based on the dynamics of mass movement of cohesionless granules (eg sand, grains and snow) (Hutter et al. 2005).

Another method used is snowpack modelling, such as the SNOWPAK-model by (Bartelt and Lehning 2002), which was developed to predict and monitor the snow cover stratigraphy and predict the stability based on meteorological conditions.

## 2.4 The Avalanche Terrain Exposure Scale

ATES, developed by Parks Canada, is a method of categorizing terrain into Simple, Challenging or Complex exposure to avalanches (Statham et al. 2007). Its purpose is to extensively evaluate, describe and communicate avalanche terrain exposure to backcountry users, mainly skiers and ice climbers, planning a trip (line feature). According to Campell et al. (2012), when a specific trip is not planned, the entire usage, or “play”, area should be evaluated according to ATES if possible. This is applied in this study for Nuolja, where skiers might take several different routes during a skiing session.

ATES is divided into a public communication model (Table 1) and a technical model (Table 2) which express the same concept but at different complexity, making it suitable for both public usage and experienced decision makers. Some of the rough descriptors in the 11 parameters that are included in the technical model carry more weight than others. These are described in italic text font and defaults into that terrain exposure category or higher. Thus, if an area mainly includes terrain factors that correspond to the simple category, but one complex italicized descriptor, the area will be categorized as complex. Non-italicized descriptors carry less weight but their combination with the other factors has to be considered (Statham et al. 2007). There are four parameters considering the terrain: Slope angle, Slope shape, Forest density and Terrain traps. Another terrain factor that should be included when implementing ATES on a high resolution is Aspect. Six of the factors are related to previous avalanches: Avalanche frequency, Runout zone characteristics, Start zone density, Interaction with avalanche paths, Route options and Exposure time. According to Campell et al. (2012) these factors usually requires some field experience to be implemented. The last parameter in Glaciation which is more related to ice climbing.

According to the developers (Statham et al. 2007) the next logical step of ATES would be to implement it in GIS and there has been some attempts of doing this, e.g. (Delparte et al. 2008) who implemented ATES in combination with a statistical runout model to estimate avalanche paths in Glacier National park in Canada; Gavaldà et al. (2013) who implemented ATES in the Aran Valley in Central Pyrenees to improve the avalanche

information in the area; or Campell and Marshall (2010) who mapped several snow mobile areas in British Columbia.

According to Campell et al. (2012), a useful improvement, that also is applicable in GIS, would be to add a “no avalanche” category which could be useful for backcountry users when, for example, locating a suitable site to set camp. An example of an area that might be categorized as no avalanche terrain is dense forest with 1000 trees per hectare (BC NRS 2011). Campell et al. (2012) also discusses how an algorithm for automatically classifying exposure according to ATES would be preferred, but is not suitable in the current model which requires a degree of user knowledge since some parameters cannot be digitally modelled. Furthermore

Table 1: ATES Public Communication model

Description	Class	Terrain Criteria
<b>Simple</b>	<b>1</b>	Exposure to low angle or primarily forested terrain. Some forest openings may involve the runout zones of infrequent avalanches. Many options to reduce or eliminate exposure. No glacier travel.
<b>Challenging</b>	<b>2</b>	Exposure to well defined avalanche paths, starting zones or terrain traps; options exist to reduce or eliminate exposure with careful routefinding. Glacier travel is straightforward but crevasse hazards may exist.
<b>Complex</b>	<b>3</b>	Exposure to multiple overlapping avalanche paths or large expanses of steep, open terrain; multiple avalanche starting zones and terrain traps below; minimal options to reduce exposure. Complicated glacier travel with extensive crevasse bands or icefalls.

Table 2: ATES technical model

	1 - Simple	2 - Challenging	3 - Complex
<b>Slope angle</b>	Angles generally < 30°	<i>Mostly low angle, isolated slopes &gt;35°</i>	<i>Variable with large % &gt;35°</i>
<b>Slope shape</b>	Uniform	Some convexities	Convoluted
<b>Forest density</b>	Primarily treed with some forest openings	Mixed trees and open terrain	Large expanses of open terrain. Isolated tree bands
<b>Terrain traps</b>	Minimal, some creek slopes or cutbanks	Some depressions, gullies and/or overhead avalanche terrain	<i>Many depressions, gullies, cliffs, hidden slopes above gullies, cornices</i>
<b>Avalanche frequency (events:years)</b>	1:30 ≥ size 2	1:1 for < size 2 <b>1:3 for ≥ size 2</b>	1:1 < size 3 <b>1:1 ≥ size 3</b>
<b>Start zone density</b>	Limited open terrain	Some open terrain. Isolated avalanche paths leading to valley bottom	Large expanses of open terrain. Multiple avalanche paths leading to valley bottom
<b>Runout zone characteristics</b>	Solitary, well defined areas, smooth transitions, spread deposits	Abrupt transitions or depressions with deep deposits	Multiple converging runout zones, confined deposition area, steep tracks overhead
<b>Interaction with avalanche paths</b>	Runout zones only	Single path or paths with separation	<i>Numerous and overlapping paths</i>
<b>Route options</b>	Numerous, terrain allows multiple choices	A selection of choices of varying exposure, options to avoid avalanche paths	<i>Limited chances to reduce exposure, avoidance not possible</i>
<b>Exposure time</b>	None, or limited exposure crossing runouts only	<i>Isolated exposure to start zones and tracks</i>	<i>Frequent exposure to start zones and tracks</i>
<b>Glaciation</b>	None	<i>Generally smooth with isolated bands of crevasses</i>	<i>Broken or steep sections of crevasses, icefalls or serac exposure</i>

“Terrain that qualifies under an *italicized* descriptor automatically defaults into that or a higher terrain class. Non-italicized descriptors carry less weight and will not trigger a default, but must be considered in combination with the other factors.” (Statham et al. 2007).



## 2.5 Study Area

The mountain of Nuolja is located at 68° north, 18° east, towards the west from Abisko in the municipality of Kiruna, Sweden (Figure 2). The landscape in the area shows traces from previous ice ages and contains the famous u-valley of Lappporten. The highest peak of Nuolja mountain is located 1169 meters above sea level and the tree limit is generally at 600 m.a.s.l. The trees are dominated by mountain birch (*Betula pubescens*) and other than that the vegetation is relatively low growing as a result of the high latitude. The annual precipitation is relatively low due to rain shadowing from the moist Atlantic eastward winds by mountains in the west. With less snow the avalanche risk might be relatively lower in Nuolja compared to western mountains.

The topography of the study area (Figure 3) has a general aspect towards the east and the inclination is generally lower in the southern parts of the mountain than the northern. The ski area includes one ski lift stretching from about 390 to 900 meters above sea level. There is no prepared ski piste in Nuolja so the way back down to the lift is through off-piste skiing on a route of own choosing, or following one of the 16 recommended routes. Preventive measures for avalanche accidents are done in some areas close to the ski lift. Other than that, avalanches are a reoccurring threat for winter sport recreationists.

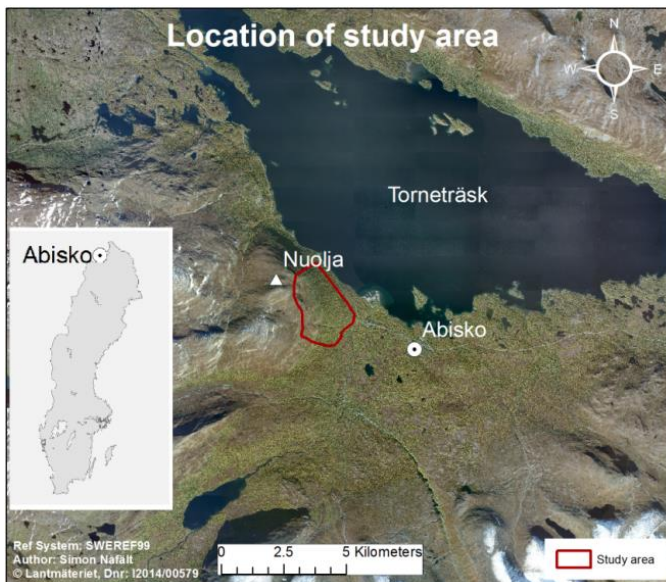

Figure 2: Location of study area

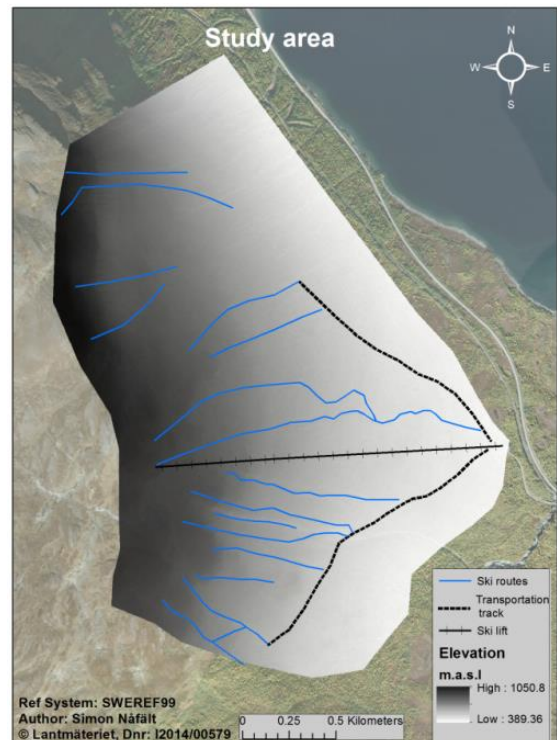

Figure 3: The study area in Nuolja

### 3. Method

Published literature, reports, proceedings and books was mainly studied in order to establish the theoretical framework for avalanche risk assessment in general and the Avalanche Terrain Exposure Scale, as well as defining key terms, definitions and terminology. An experimental implementation of the Avalanche Terrain Exposure Scale in a geographical information system (GIS) was also made.

#### 3.1 Data

**GSD-Höjddata, 2m+** - The two meter resolution digital elevation model (DEM) used, was acquired from Lantmäteriet (Swedish national land survey). It was developed by laser scanned points, taken every second meter, converted to a grid surface through Triangulated Irregular Network (TIN) interpolation.

**GSD-Vegetationsdata** - Vegetation map from Lantmäteriet containing vegetation types in vector surfaces with description provided in attached document. The classification in the data has been done by interpretation of infrared flight photos.

**GSD-Ortofoto** – Orthophoto grid from Lantmäteriet containing radiometrically processed flight photos to adjust for the effects of central projection and used to interpret vegetation density.

**Avalanche documentation** – Documentation of past avalanches in Nuolja kept by STF Abisko turistcenter. Data that was acquired covered year 2002, 2003 and month 2-4 2016 and includes various data on location, triggered type, size and in which terrain features it occurred. Full documentation can be found in Appendix 2.

#### 3.2 Implementing the Avalanche Terrain Exposure Scale

This experimental analysis was done in ESRI ArcGIS software and mainly through spatial analysis and the hydrological tools. To implement ATES in GIS and without field experience or possibility to evaluate each area “case by case” due to the size of the study area, the model parameters and categories had to be quantified. Due to frequent use of terms like *generally*, *mostly* this quantification was done subjectively based on knowledge from literature. The technical model (Table 1) was weighted both by parameters (rows) and terrain exposure categories (columns) as seen in Table 3. The columns were weighted 0.33, 0.66 and 1,

Table 3: The method of weighing the ATES technical model.

ATES index table					
	A	B <sub>1</sub>	B <sub>2</sub>	B <sub>3</sub>	C
Factor	Weight %	Simple	Challenging	Complex	A*B <sub>x</sub>
Aspect	10	0.33	0.66	1	Cell value
Slope angle	25	0.33	0.66	1	Cell value
Slope shape	5	0.33	0.66	1	Cell value
Forest density	10	0.33	0.66	1	Cell value
Terrain traps	10	0.33	0.66	1	Cell value
Avalanche frequency (events:years)	20	0.33	0.66	1	Cell value
Start zone density	5	0.33	0.66	1	Cell value
Runout zone characteristics	5	0.33	0.66	1	Cell value
Interaction with analanche path/ Exposure time	10	0.33	0.66	1	Cell value
Sum	100				Index value

representing Simple-, Challenging- and Complex terrain respectively and each parameter importance was determined subjectively. Parameters were generally assigned a higher importance if they had italicized descriptors or a lower level of subjectivity in the original ATES-model. In this way the italicized descriptors was integrated in the model, instead of handled separately, which made the method more suitable for GIS.

A two meter resolution grid surface, divided into the three ATES categories, was developed for each parameter if possible. With this approach, a cell-by cell analysis could be done and the resulting map would have a comprised ATES-index.

Two ATES parameters: glaciation and route options was not used in this attempt since they were deemed irrelevant (See section 3.2.8 below).

### 3.2.1 Slope inclination

Both inclination and aspect was derived from the digital elevation model. Inclination, which is one of two parameters in ATES with a quantitative description, was divided into the terrain categories by thresholds of  $<25^\circ$ ,  $25^\circ$ - $35^\circ$  and  $>35^\circ$  seen in Figure 4. ATES describes simple inclination as “*generally less than 30 degrees*” and Mcclung and Schaerer (2006) describes how avalanche generally occurrence at more than  $25^\circ$  inclination. The threshold for simple terrain was therefore set to  $<25^\circ$  to be a bit conservative and reduce risk of under estimation of avalanche risk. Complex terrain was set to inclinations more than  $35^\circ$  and challenging terrain, which ATES defines as “*generally low angles and some isolated slopes  $>35^\circ$* ”, was set to inclinations ranging between the thresholds that where set for simple and complex terrain. Since inclination is a very prominent parameter and had two italicized descriptors it was given a weight of 25%.

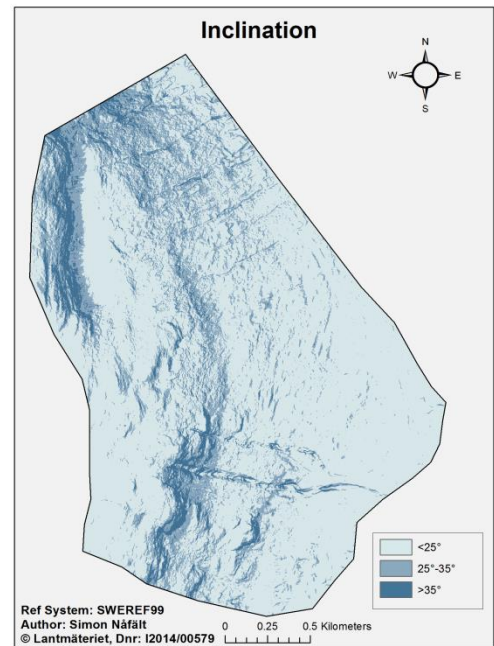

Figure 4: Inclination parameter surface

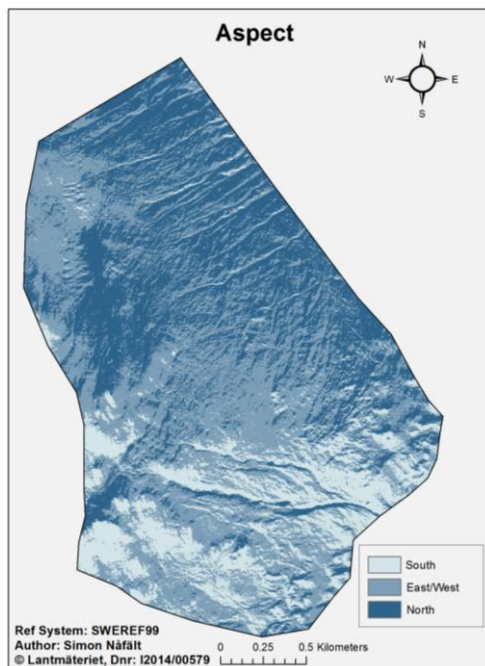

Figure 5: Aspect parameter surface

### 3.2.2 Aspect

Aspect is not defined by ATES technical model but is according to the developer (Statham et al. 2007) a factor that has to be considered on a high resolution analysis. As explained in section 2.2.3 this report, due to sun radiation, north facing slopes generally develops instability and south facing slopes gain stability during winter months. Therefore north facing aspects where set to complex, east and west aspects as challenging and southern aspects as simple (Figure 5). Since statistics about aspect and its relation to accidents are clear but its impact on avalanches is debated (see aspect in section 2.2.3), the parameter was weighted 10%.



### 3.2.3 Slope shape

The slope shape, or “the slope of the slope”, was derived from the DEM, with a spatial analysis tool in ArcGIS, to display if a slope is convex or concave in a cell. The ATES model categorises slope shape into *uniform*, *some convexities* or *convoluted*. Since the model was developed to plan a trip which stretches over larger areas, the slope shape in each 4 m<sup>2</sup> cell doesn't represent the general slope shape in a larger area. Instead the variance and range of the slope shape values over 25x25 cells was used to determine if a slope was generally flat (uniform) or of irregular shape (convoluted). This generalization led to some loss in data but increases the compatibility to the description in ATES. Large variance of cell values in an area was classified as complex, low range of cell values in an area was classified as simple and challenging slope shape was determined to be the remaining area (Figure 6). The slope shape, as defined in ATES, has no italicized descriptors and is also hard to define in GIS software. Therefore it was set to 5% parameter importance.

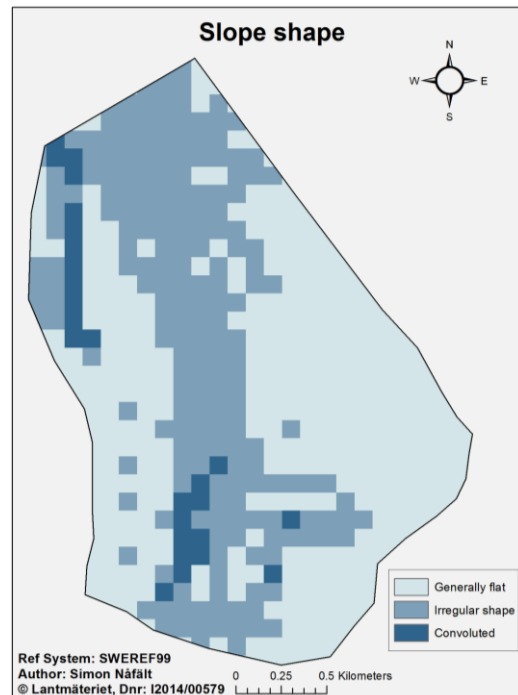

Figure 6: Slope shape parameter surface

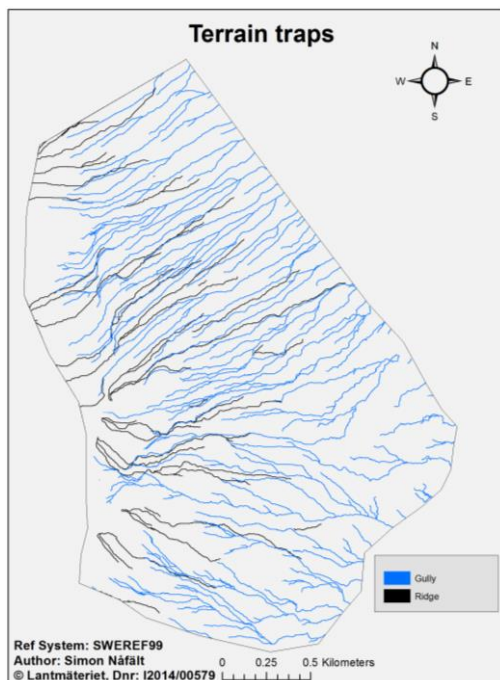

Figure 7: Highest stream order complex terrain traps

### 3.2.4 Terrain traps

For the terrain trap analysis, focus was put entirely on gullies and ridges. The gullies were defined through hydrological modelling based on the DEM. The tool used calculates areas of accumulated flow of water which corresponds to areas where gullies usually form. The three ATES categories for terrain traps are defined *minimal*-, *some*- and *many* traps. Instead of taking the same approach as with slope shape, to make a quantitative analysis over larger areas, the terrain traps were instead kept at two meter resolution since the specific location of traps was believed to be more suitable for a slope scale analysis. The accumulation of flow was instead divided by a method of stream order operation, proposed by Strahler (1957) which led to a stream network with six orders. The largest gullies, 5<sup>th</sup> and 6<sup>th</sup> stream order, were categorized as complex (Figure 7), 4<sup>th</sup> and 3<sup>rd</sup> order as challenging and 1<sup>st</sup> and 2<sup>nd</sup> order as simple terrain traps. This led to a modification of ATES that instead would

correspond to a minimal-, medium- and maximum trap *size* and the italicized descriptor in the complex category was considered a normal descriptor.

For ridges, which are common places for formation of cornices, the same procedure was done but the input DEM was multiplied by -1 to reverse the values. The bottom of the stream order then represented the highest ridges (Figure 7) that are more exposed to winds

which is the main driver in cornice formation (McClung and Schaerer 2006). The parameter was assigned a weight of 10% importance.

### 3.2.5 Forest/Vegetation cover

Visual interpretation of the aerial photography in combination with vegetation map provided sufficient information about the extent of the forest and open areas. These could then be categorized as simple and complex terrain and the semi covered area in between as challenging (Figure 8). Vegetation cover was weighted relatively high at 10% due to its impact on avalanche occurrence explained in section 2.2.3.

### 3.2.6 Avalanche frequency

The data needed for frequency of avalanches in the ATES parameters is number of avalanches per year and what size they were, according to the North American Danger Scale. This scenario posed some problems. First of all, the plan was to divide the whole area into the three ATES categories but in this case, areas that never experienced any avalanches do not fulfil the criteria for simple exposure. Secondly, the documentation only cover statistics on observed avalanches so there is probably some degree of “hidden” statistics of unobserved avalanches. The avalanche frequency parameter was therefore approached by only using the italicized descriptors of complex and challenging exposure as they would default into categories. Complex exposure was assigned to areas that experienced size three avalanches in the past and challenging exposure in areas that experienced size two avalanches in the past (see Figure 9).

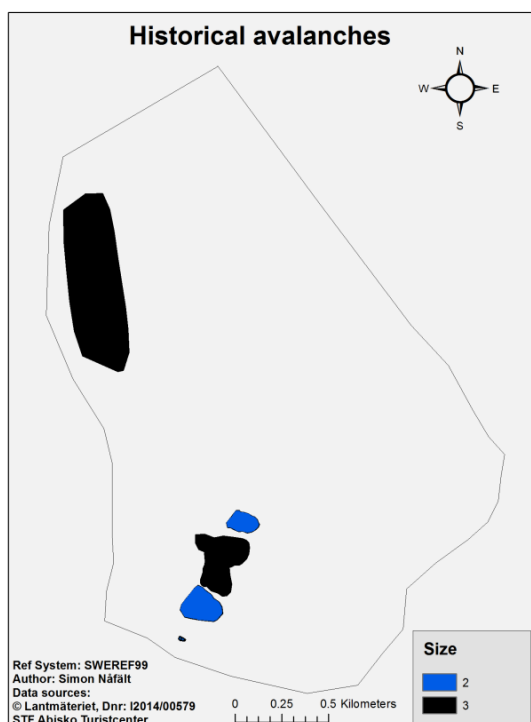

Figure 9: Size of historical avalanches (according to the North American Danger Scale) used in the analysis.



Figure 8: Vegetation cover parameter surface

Since the data on previous avalanches was not geographically tagged with coordinates, avalanche areas had to be defined based on altitude, aspect, inclination, slab width and the general description about in what off-pist route it had occurred. A complete description with all these indicators were rarely available so in some instances only some of them were used. These problems resulted in that only six past avalanches could be used. The parameter was weighted at 20% for the reason that past avalanches is the best way to predict future ones as explained in section 2.3. It also has got two italicized descriptors that carry more weight which should not be overlooked.

### 3.2.7 Start zone, track, runout zone and path

The past avalanches were divided into start zone, avalanche track and runout zone to implement the ATES-parameters that consider hazards when skiing in areas where avalanches have occurred in

the past. The parameters of start zone density, runout zone characteristics and a combination of interaction with avalanche path/exposure time (Figure 10) was used to subjectively weight each area based on knowledge gained from literature and visually analysing the aerial image, avalanche documentations and terrain data.

The documentations did not include any data on length of avalanches so the locations were presumed to represent the start zones. The general rule of avalanches stopping in slopes below  $10^\circ$  was used to determine length of the avalanches and the area between the start zones and runout zones were defined as avalanche track. Each start zone, avalanche track and runout zone was categorised according the criteria in the technical model. Start zone density and runout zone characteristics parameters were both given a 5% importance due to the high level of subjectivity and uncertainties. Interaction with avalanche path/exposure time was weighted higher, at 10%, due to an italicized descriptor in the complex category and it was a combination of two parameters.

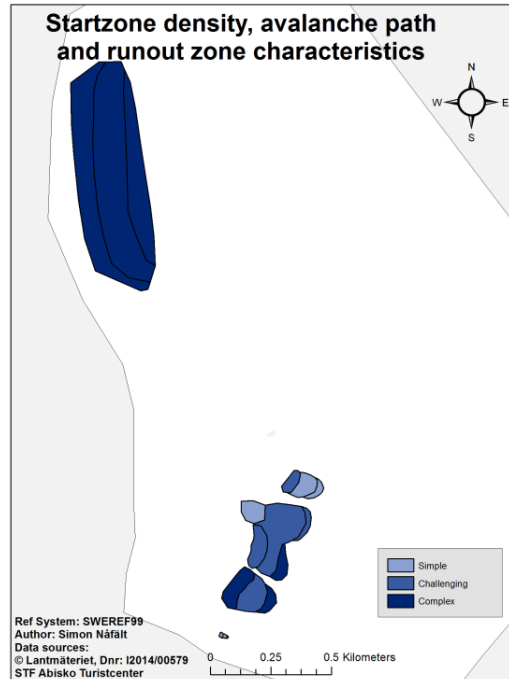

Figure 10: Avalanche path parameters divided into ATES categories

### 3.2.8 Glaciation and route options

Two parameters in the technical model of ATES were not included for different reasons. Glaciation was one of these simply because there was no glaciation in the study area. The second parameter that was excluded was route options. It describes the degree of possibilities to avoid skiing in an avalanche area which indicates a trip-scale usage that ATES was originally developed for and not the area based evaluation this study was intended as. This is also a similar concept as the one treated by terrain traps since gullies and ridges limit route options.

### 3.3 Development of ATES map

All parameters were combined according to the method in Table 3. Subjective thresholds were set in the resulting ATES-index value range to divide the map into categories of simple, challenging and complex terrain. The thresholds were determined by interpreting both the map with all factors combined and a map with only terrain factors combined. The resulting map then showed ATES-classification on a slope scale in a 2x2 meter grid format.

### 3.4 Integrating altitude in ATES

An attempt to integrate altitude in ATES was done since altitude is another terrain factor that impact avalanche occurrence. The same method was used but altitude was given an importance factor of 10% at the expense of avalanche frequency which then was reduced from 20% to 10%. This was done to get a more realistic result since the avalanche areas was considered to have been over represented in the original ATES analysis due to the parameter weighting. The categories in Figure 11 were determined based on altitude statistics on the data of

Table 4: Altitude statistics on documented

Altitude of past avalanches in Nuolja (m.a.s.l)				
Avalanche Size	0-1	1.5-2.5	3-3.5	All
Average	752	800	857	782
Minimum	650	720	800	650
Maximum	850	850	950	950

previous avalanches in the area (Table 4). The minimum altitude of that an avalanche had occurred in the documentation was 650 meters above sea level. The simple category was conservatively set to range between the minimum elevation value in the study area (389 m.a.s.l) to 600 m.a.s.l. The minimum value for large avalanches, size >3, was set as threshold for the complex category and challenging exposure was the area between simple and complex, thus ranging between 600-800 m.a.s.l. Same thresholds as in the previous analysis were used for dividing the index in the resulting map into ATES-categories to make comparisons easier.

### 3.5 Analysing the results

No ground truth data was available since the documentation on historical avalanches did not include exact geographical locations. Instead, a comparison was done to determine how well the parameter weighing corresponded to a map containing only the italicized descriptors (that default into a category). This was done in a way that the accuracy maps showed if the results were equal, under estimating or over estimating avalanche risk where the italicized map was considered “ground truth”. Since the terrain traps parameter had been modified, from quantity of traps to quality of traps, it was not used in the italicized map. Both the original ATES method and the map where altitude was integrated were analysed.

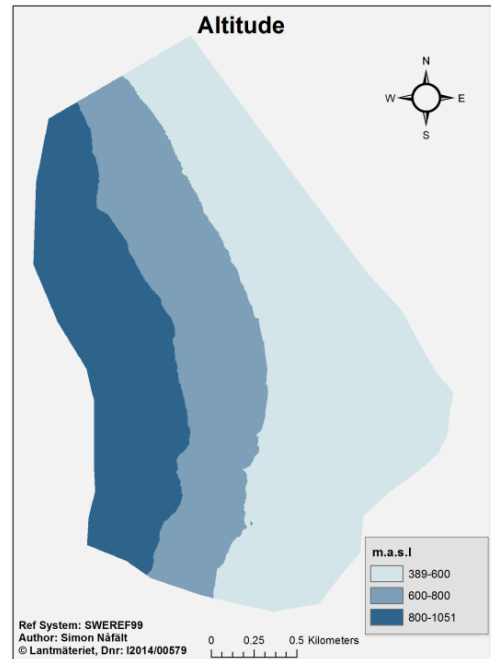

Figure 11: Altitude thresholds based on altitude of historical avalanches in Nuolja

### 3.6 Generalizing the results

Because avalanche occurrence is very hard to define and parameters are more of a rough description, the resulting two meter resolution map of the unmodified ATES method was also further generalized into vector graphics to propose a conservative map suitable for public communication of avalanche risk in Nuolja. Polygons were drawn over the map to generally delineate areas into different categories. The polygons were then modified with input from italicized descriptors to avoid under representation of avalanche exposure in the map.



## 4. Results

### 4.1 Original ATES parameters

The parameter importance weighting resulted in maps that were very dominated by the areas of past avalanches (Figure 13). Historic avalanching in an area is an important parameter to consider but in this instance, the first impression was that it seemed to have been weighted out of proportion to the terrain parameters (Figure 12).

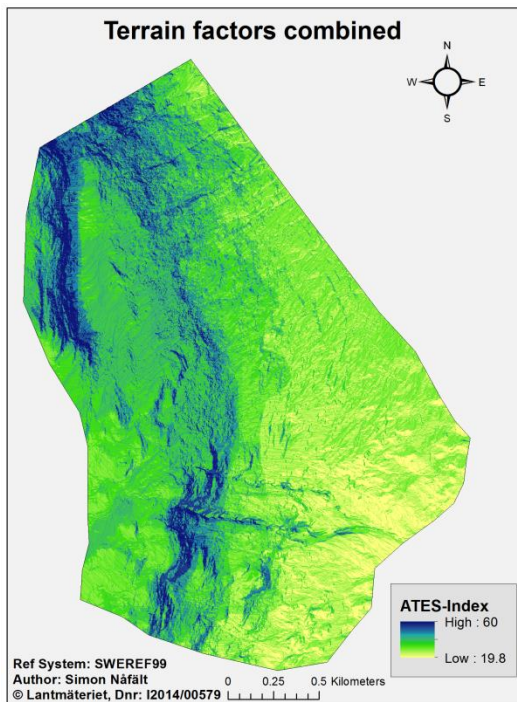

Figure 12: Result from combining terrain factors

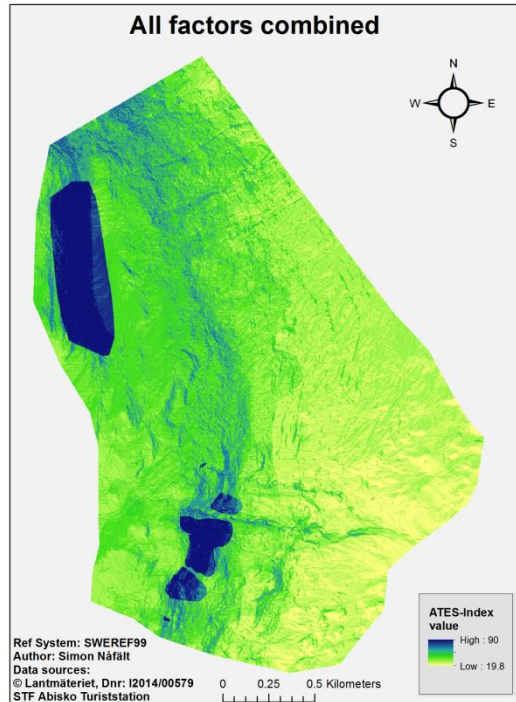

Figure 13: Result from combining all factors

A combination of the map showing all factors and the map with only terrain factors was used to determine thresholds. The terrain factors maximum index value of 60% had to be considered when dividing the values in Figure 13 so the most exposed terrain was included into the complex-category. The index values ranging between 20% and 90% was divided in such a way that  $>50\%$  represented complex terrain,  $<35\%$  represented simple terrain and values between 35% and 50% represented challenging terrain.

The resulting map in Figure 14 is dominated by simple exposure both in the lower altitudes in the eastern parts and in higher altitudes in south western parts. Challenging exposure is mainly found steeper northern parts but also along a passage across in mid-altitudes. Regardless of avalanche size, the avalanche areas generally resulted in complex exposure. Except that, complex exposure is found in the steep slopes in the northern part of the map and scattered in mid altitudes in connection to

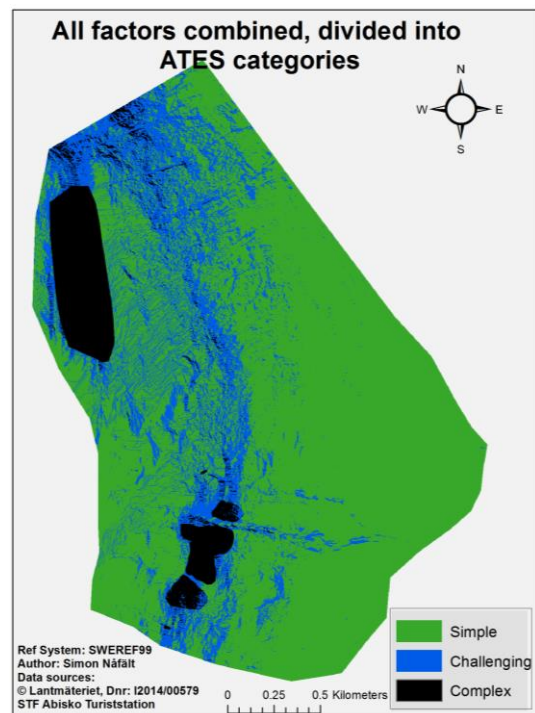

Figure 14: Resulting ATES map in 2m resolution



challenging exposure.

## 4.2 Integrating altitude in ATES

When looking at terrain parameters combined with altitude, there is a noticeable difference between the general values in the low altitudes and the rest of the study area (Figure 15). This is mainly because the altitude parameter is similar to the forest density parameter. Their combination led to a more distinct separation of the low values and the forest, which is better suited according to the theory that avalanches generally don't occur in forest areas, explained in section 2.2.3.

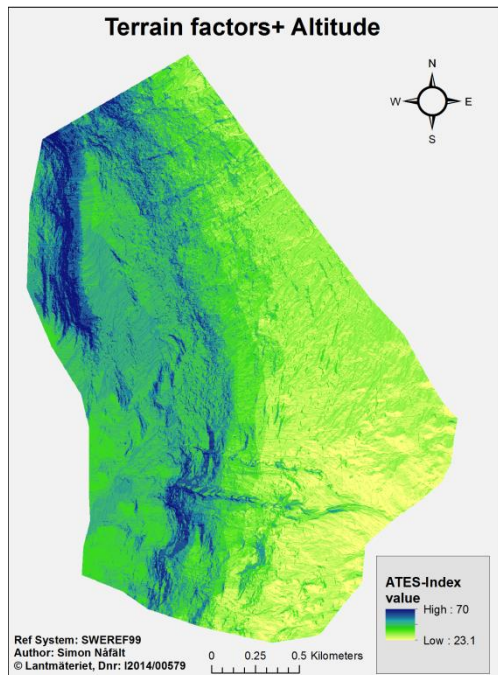

Figure 15: Modified ATES. Terrain and altitude factors combined

With altitude integrated in the model, and thus lowered impact of avalanche frequency, the resulting map (Figure 16) show that areas of previous avalanches were not as distinct in the map and thus seemed more assimilated with the terrain parameters. Previous avalanche areas still exhibits the highest exposure index value of 90%. However, avalanches with size two (challenging exposure) did not always exceed the terrain index values. The same threshold values are used in Figure 17 as in the previous section. The parameter importance modifications led to more areas with high terrain index value were included in the complex category together with areas of previous avalanches. Also, many areas in higher altitudes that previously were categorized as simple were now included in the challenging category.

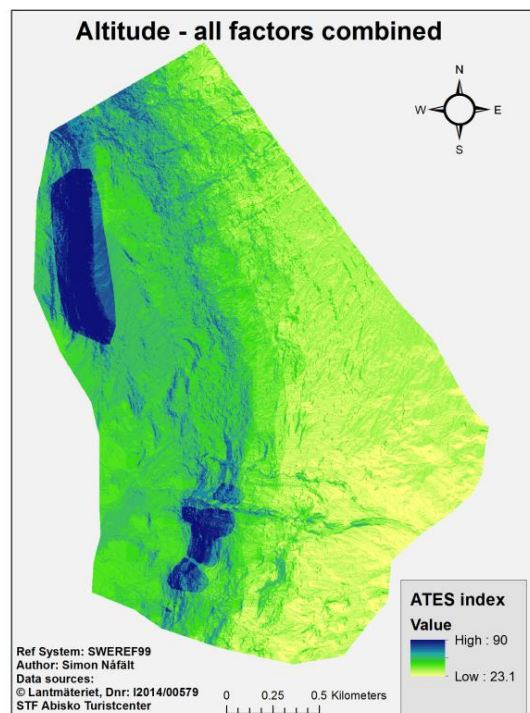

Figure 16: Modified ATES. All factors and altitude factors combined

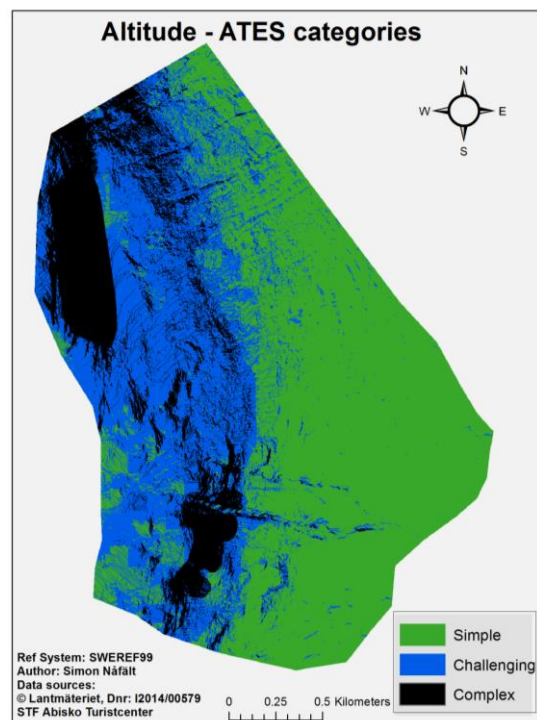

Figure 17: Modified ATES. Resulting ATES map in 2m resolution

### 4.3 Analysing the results

A map made from italicized descriptors (Figure 18), which include slope inclination and previous avalanches exclusively, were compared to the results from the two ATES implementations (Figure 14 & 17). An under estimation means that the resulting map display a lower category in an area compared to the italicized map and an over estimation mean that the resulting map display a higher category than the italicized map. In general, the italicized descriptors were under estimated in eastern half of the study area and over estimation in the western half of the area by the original ATES method (Figure 19). This is also true, and more prominent, when doing the same comparison for when altitude was included (Figure 20). The exposure category in the size-2 avalanches are generally over estimated in both cases.

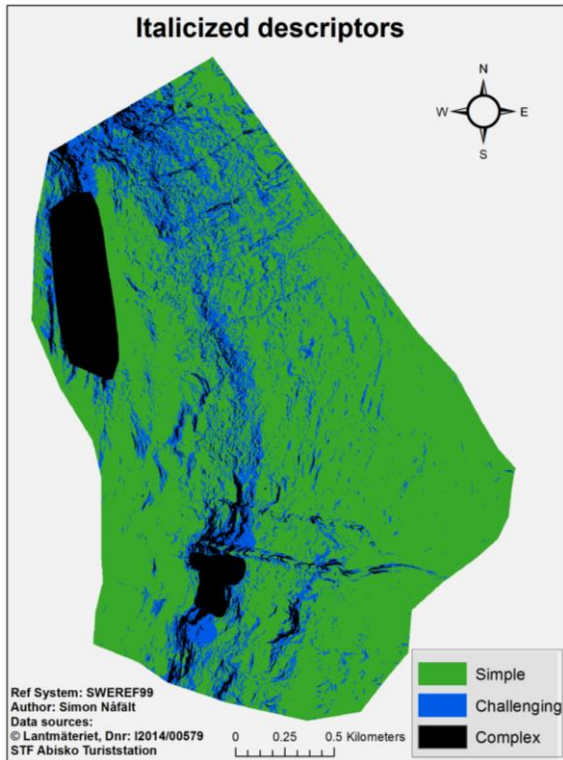

Figure 18: Map of italicized descriptors

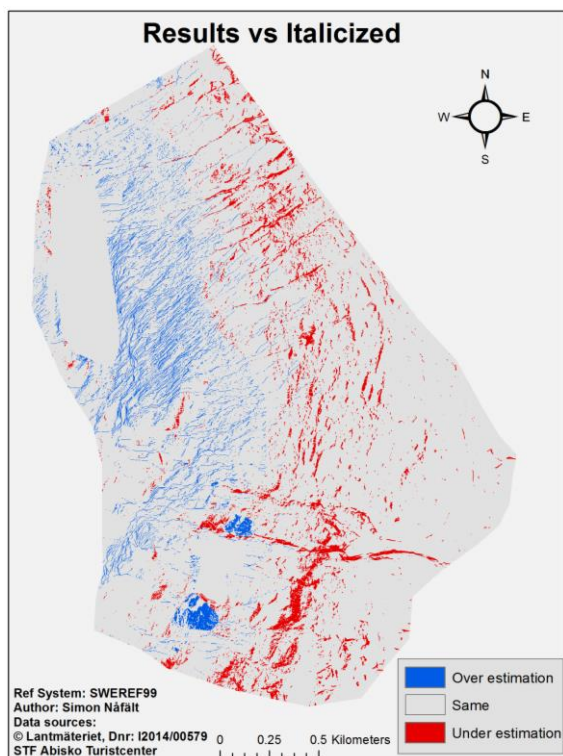

Figure 19: Original ATES method compared to italicized descriptors

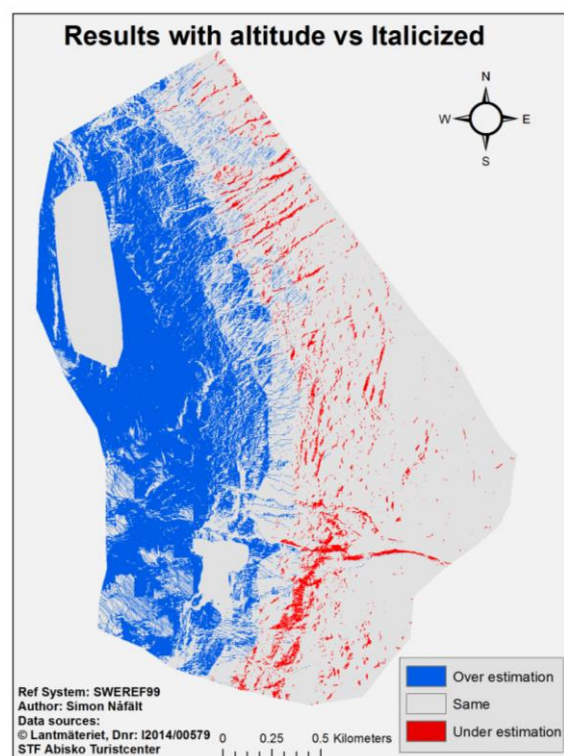

Figure 20: Modified ATES method compared to italicized descriptors

#### 4.4 Generalized results

The generalized result (Figure 21) gave a more conservative and easier to interpret, map of ATEs categories in Nuolja which is more suited for public communication of avalanche risk. The complex category dominates areas with steep inclinations exposed to reoccurring avalanche events as well as areas in deep gullies that form terrain traps.

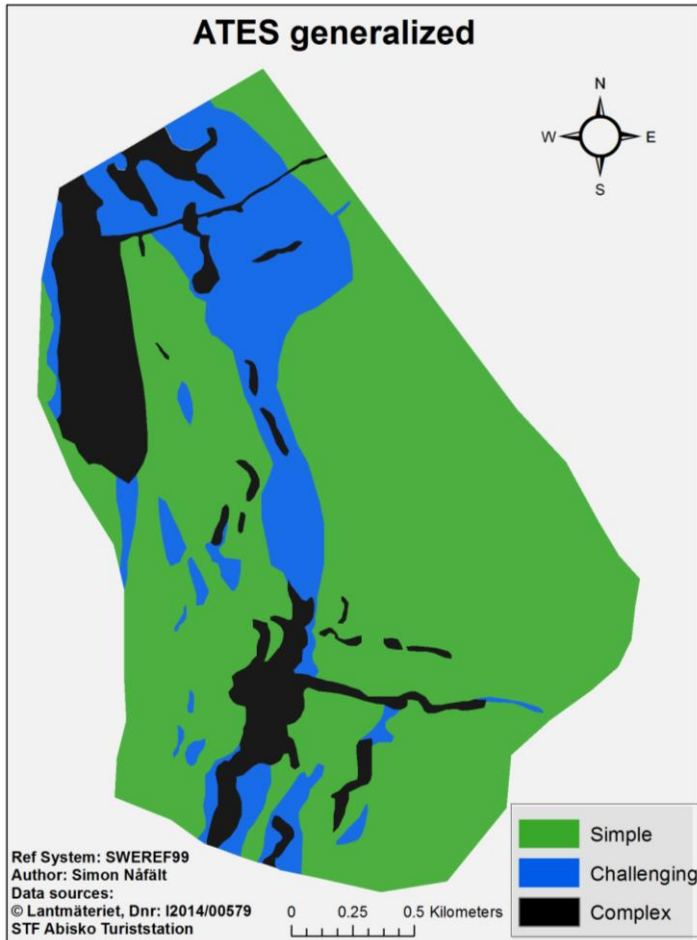

Figure 21: Proposed generalization into an ATEs map suited for public communication

## 5. Discussion

### 5.1 Data

The digital elevation model might have some small errors due to the interpolation process even though the TIN-interpolation used, is well suited for representing terrain. The only drawback could be that the method is quite sensitive to outliers and thus single measuring errors might have a large impact. The vegetation data did not include metadata on density of trees in the forest which would have been a helpful input. Mountain birch (*Betula pubescens*) is a small-growing species which avalanche prevention abilities probably differs from the dense forest that BC NRS (2011) define as non-avalanche terrain. There are a lot of voids in the avalanche documentation that made most of the avalanche events unusable even though avalanche areas were determined with a high degree of subjectivity. Out of the 68 avalanches only about 10 events had an adequate description, both about location, length and width, to make an estimation of their coverage area plausible. Some location descriptions could not be found in the ski map of Nuolja e.g. *Branten* and *Vindtunneln*. These locations are described in the events from 2002-2003 so it might be historic names or paths that no longer exists in the ski map. STF Abisko Turistcenter was contacted about this without results.

### 5.2 Implementation of ATES in GIS

The high amount of subjectivity in the ATES model put demands on user knowledge and thus results might vary a lot based on user background. The parameters of terrain traps and slope shape were found difficult to define during this experimental GIS approach and the methods used were not scientifically attested in publications. Also, the ambiguous description of parameters in ATES is not very well suited for GIS-analysis since it requires quantitative input. However, with a subjective description the user has the possibility so make smaller modifications in the method to fit the specific conditions of a study area and base it on the rough descriptions provided by the model. In Nuolja this could be implemented by, for example, lowering the importance of aspect due to the lower exposure to sun radiation in the winter months at this latitude. Or the general risk might be lower in Nuolja due to the relatively low precipitation amount. Local knowledge could therefore be helpful.

#### Aspect and inclination

Neither the inclination nor the aspect weighting are based on slope usage (Schweizer et al. 2003; Mcclung and Schaerer 2006). This means that statistics might show that accidents occur more in north aspects just because the majority of skiers use those slopes. Improved knowledge about this could strengthen the usefulness of GIS in ATES-analysis since determination of slope and aspect from a DEM requires relatively simple one-step operations.

#### Terrain traps

The stream order operation used to define gullies and ridges in the terrain is based on calculations of flow direction and flow accumulation of water on a surface. There are several different methods and algorithms for how flow is directed in a grid surface. The GIS software used in this study, ArcGIS, uses a general method of single direction flow. This means that the flow is directed from the higher cell value to the lowest neighbouring cell value, which is not always the case in real world situations. Pilesjo and Hasan (2014) tested and compared several flow direction algorithms and in their results the ArcGIS single direction method produces the poorest results.

The ridges were developed by inverting values in the DEM and implement the same procedures as with gullies. The shape of a natural surface has been developed on large time scales through erosion, driven mainly by water and gravity. By reversing the DEM an



unnatural surface is created that might have features that makes the flow direction algorithms incompatible. For example, if a generally flat slope has a rock outcrop, the flow will be directed around it. If the surface is reversed, this rock outcrop will become an unnatural sink that might prevent further flow and thus the detection of ridges in the “shadow” beyond it.

### **Forest Density**

Since the density of the forest cover was unknown and it mainly consists of a low-growing bush-like birch, the weighting in the simple terrain of ATES might be suitable. If the forest would have been a dense coniferous forest, that is common in Sweden, a weighting of 33% might have been too high. In this case it could have been suitable to introduce the “no avalanche” category proposed by Campell et al. (2012). The combination of other factors would still have to be considered but in this case in Nuolja, a lot of the forested area has got a generally flat slope, a low inclination angle and, as far as the documentation show, no avalanche activity (below 650 m.a.s.l).

### **Avalanche factors**

There were high amount of drawbacks when the GIS method was tested considering the avalanche factors and its usage as field experience. First of all, there was a high level of subjectivity since both locations and weighting was producer determined. The terrain description of where the avalanches had occurred was a general description since number often where rounded. Avalanche width to the closest 50 meters and slab depth to the closest 5 cm. There was also no information on slab length or length of the whole avalanche path which is needed in ATES and instead the general rule about angle of runout zones worldwide had to be used. A better way could have been to use a runout model to estimate the avalanche patch, but the data needed for that was not available. Without information about width, polygons of avalanches could simply not be drawn.

Trying to implement ATES without real field experience turned out to be very difficult in this case. If detailed data on historical avalanche events would be available, that could greatly improve the results and lower the subjectivity. The subjectivity also poses possible drawbacks in terms of accuracy on a slope scale resolution. When avalanche areas have to be estimated subjectively it has to be done conservatively, so avalanche risk is not under estimated, which leads to loss of accuracy in the resulting map. However, on a larger scale showing risk areas in general, this conservativity might be a better way to present avalanche risk to skiers to avoid future accidents.

The categories in the avalanche parameters of ATES only deal with areas affected by avalanches. The simple category on avalanche frequency is defined as: one avalanche size 1 every 30 years. Areas that never were affected by an avalanche therefore do not fulfil the criteria for the lowest category. This is another case where the “no avalanche” category could be useful when using GIS. When implementing the map algebra, as done in this study, it is preferable if the whole area in the avalanche parameters has a quantitative value and not left as “no data”. Otherwise the areas with avalanche weights have an “extra parameter” when weights from all maps are added together. An alternative could be to weight the “no data” areas as simple, just to have values in the whole parameter map, but then many areas could be over or under estimated.

The subjectivity was taken one step further when weighting the start zones, avalanche tracks and runout zones since each zone was already determined- and then weighted- subjectively based on remote sensing of the terrain. This subjectivity might almost reach levels were it is no longer acceptable to use it but, as explained in section 2.3, previous avalanche occurrence is the best way to predict future avalanches so excluding it was

determined less acceptable. Giving the avalanche parameters a lower importance would be a better alternative.

### **Altitude**

The ski area has a vertical height range of about 700 meters. This is a relatively short range that was divided into the three ATES categories and thus it is very specifically adapted for Nuolja. For it to be applicable in more places than Nuolja and to see if there in fact is a correlation between avalanches and altitude, a larger dataset of avalanches worldwide would have to be statistically analysed. To instead base the altitude parameter on the physical properties of how wind and temperature change with altitude is also an alternative that could be investigated.

## **5.3 Results**

Even though this study assessed avalanche risk on a high resolution slope scale, the subjectivity of the method and uncertainties in avalanche factors make the resulting maps display a general risk. When comparing the original ATES model with the modified model, which incorporates altitude, the overall general impression in the study area changes from simple to challenging exposure. This can be explained by the modification of the model where the terrain parameters had increased importance, and thus generally higher index values, but the thresholds for the ATES categories were unchanged. Since the threshold values were somewhat based on the terrain index values (explained in section 3.3), a large part of the map was categorized into a higher category. It might have been better to make new subjective threshold values for the modified model but this poses problems when comparing the results. However, the high exposure risk areas were generally in similar locations but to different extent, and the extent is a result of the subjective thresholds.

### **Evaluation of results**

Due to the complexity and uncertainties in avalanche science it is hard to evaluate the results. An alternative could have been to exclude some historical avalanches in the analysis and use them as ground truth. Since only a few documented avalanches could be used and the fact that their locations were very generalized and subjective, this was not an alternative.

Most of the underestimation compared to the italicized descriptors is in areas with the combination of high inclination angle, low altitudes and occurrence of forest. Some avalanche experts say that avalanches can occur on any slope (McClung and Schaerer 2006) and other say that avalanches can't occur in dense forest (BC NRS 2011). Due to this and uncertainties explained before it is therefore hard to determine the relevance of the evaluation.

### **Generalizing the results**

For public communication of avalanche risk, a two meter resolution map, with the amount of subjectivity included, might not be suitable. A generalized and conservative map of exposure could be a better way to present the avalanche risk even though it loses some accuracy. With sufficient data and knowledge, a high resolution map could be developed. However the question is if that is a suitable way to communicate avalanche risk to the public since showing avalanche exposure at that scale somewhat contradicts the fact that knowledge about avalanche occurrence is not fully understood. This might instead get a reverse effect on backcountry users that get a sense of false security when navigating through the terrain.

#### **5.4 Further studies**

The way the technical model of ATES is setup now, it is hard to include every aspect of the exposure risk in a GIS-analysis. The method is very user demanding and human bias is reoccurring throughout implementation. An idea could be to develop a separate ATES model that is better suited for GIS with more quantitative thresholds in the subjective terms. A way to handle the subjective descriptions could be to implement fuzzy logic, which is a type of “many-values” logic that can be suitable when modelling a vague phenomenon such as avalanches (Novák 2005). With a computerized model it also would become easier to include varying factors, like meteorological parameters, which could lead to better and up-to-date avalanche risk maps that could be communicated to the public continuously.

## 6. Conclusion

Due to uncertainties and complexity in avalanche science, risk assessment is still largely dependent on knowledge from field experience. This, combined with the lack of quality in data, makes it a very challenging phenomenon to model and development is still a work in progress.

The Avalanche Terrain Exposure Scale is a valuable tool for assessing avalanche risk but the results are highly dependent on the producer. The technical model of ATES, as it is today, is problematic to use in GIS due to the lack of quantitative descriptions.

The experimental implementation of ATES without field experience proved to be very difficult. Insufficient data led to a result in lower resolution than what was aimed for and it included a lot of subjectivity. Incorporating altitude did not show any clear improvement though due to lack of time and general uncertainties, the results were not thoroughly analysed.

Public communication of avalanche risk on a small scale map is difficult due to the background knowledge needed to fully interpret it.



## 7. References





- Ancey, C. 2001. Snow Avalanches. In *Geomorphological Fluid Mechanics*, eds. N. J. Balmforth, and A. Provenzale, 319-338. Berlin, Heidelberg: Springer Berlin Heidelberg.
- Baggi, S., and J. Schweizer. 2009. Characteristics of wet-snow avalanche activity: 20 years of observations from a high alpine valley (Dischma, Switzerland). *Natural Hazards*, 50: 97-108. DOI: 10.1007/s11069-008-9322-7
- Barbolini, M., U. Gruber, C. J. Keylock, M. Naaim, and F. Savi. 2000. Application of statistical and hydraulic-continuum dense-snow avalanche models to five real European sites. *Cold Regions Science and Technology*, 31: 133-149. DOI: 10.1016/S0165-232X(00)00008-2
- Bartelt, P., and M. Lehning. 2002. A physical SNOWPACK model for the Swiss avalanche warning: Part I: numerical model. *Cold Regions Science and Technology*, 35: 123-145. DOI: [http://dx.doi.org/10.1016/S0165-232X\(02\)00074-5](http://dx.doi.org/10.1016/S0165-232X(02)00074-5)
- BC NRS, 2011. Avalanche Safety Plan. British Columbia Public Service Natural Resource Sector for General Wilderness Activities, Report.
- Campell, C., B. Gould, and J. Newby. 2012. Zoning with the avalanche exposure scale. In *International Snow Science Workshop*, Anchorage, Alaska.
- Campell, C., and P. Marshall. 2010. Mapping exposure to avalanche terrain. In *International Snow Science Workshop*, Squaw Valley, Ca.
- Colbeck, S. C., and J. B. Jamieson. 2001. The formation of faceted layers above crusts. *Cold Regions Science and Technology*, 33: 247-252. DOI: 10.1016/S0165-232X(01)00045-3
- Conway, H., and C. F. Raymond. 1993. Snow stability during rain. *Journal of Glaciology*, 39: 635-642.
- Delparte, D., B. Jamieson, and N. Waters. 2008. Statistical runout modeling of snow avalanches using GIS in Glacier National Park, Canada. *Cold Regions Science and Technology*, 54: 183-192. DOI: 10.1016/j.coldregions.2008.07.006
- Fjällsakerhetsrådet. Lavinsäkerhet. Retrieved 19 April 2016, from <http://www.fjallsakerhetsradet.se/forberedelser/laviner/Faktaomlaviner/>.
- Fjällsakerhetsrådet. 2015. Klassning av lavinterräng i svenska fjällen. Retrieved 11 April 2016, from <http://www.fjallsakerhetsradet.se/forberedelser/laviner/lavinterrangklassning/>.
- Foehn, P., M. Stoffel, and P. Bartelt. 2002. Formation and forecasting of large (catastrophic) new snow avalanches. In *International Snow Science Workshop*, Penticton, British Columbia.
- Gavaldà, J., I. Moner, and M. Bacardit. 2013. Integrating the ATES into the avalanche information in Aran Valley (Central Pyrenees). In *Proceedings of the International Snow Science Workshop, Grenoble, France*, 381-384.
- Gleason, J. 1994. Review-Terrain parameters of avalanche starting zones and their effect on avalanche frequency. In *International Snow Science Workshop*, Snowbird, Utah.
- Göransson, U., U. Blomberg, and S. N. Fjällsakerhetsrådet. 1984. *Snö och laviner: om lavinfara, hjälpmedel, räddning m m*. Institutionen, Univ.
- Haegeli, P., and J. Schweizer. 2015. Recent developments in applied snow and avalanche research. *Cold Regions Science and Technology*, 120: 153-156. DOI: 10.1016/j.coldregions.2015.09.008
- Harbitz, A., D. Issler, C. J. Keylock, and U. Gruber, 1999. SAME Avalanche Mapping, Model Validation and Warning Systems, Summary Report. European Commission, Report.

- Hutter, K., Y. Wang, and S. P. Pudasaini. 2005. The Savage–Hutter avalanche model: how far can it be pushed? *Philosophical Transactions of the Royal Society of London A: Mathematical, Physical and Engineering Sciences*, 363: 1507-1528.
- Lied, K., and S. Bakkehoi. 1980. Empirical calculations of snow-avalanche run-out distance based on topographic parameters. *Journal of Glaciology*, 26: 165-177.
- Logan, N. 1992. Snow temperature patterns and artificial avalanche release. In *International Snow Science Workshop*, Breckenridge, Colorado.
- Luckman, B. H. 1978. Geomorphic Work of Snow Avalanches in Canadian Rocky Mountains. *Arctic and Alpine Research*, 10: 261-276. DOI: 10.2307/1550759
- Maggioni, M., and U. Gruber. 2003. The influence of topographic parameters on avalanche release dimension and frequency. *Cold Regions Science and Technology*, 37: 407-419. DOI: [http://dx.doi.org/10.1016/S0165-232X\(03\)00080-6](http://dx.doi.org/10.1016/S0165-232X(03)00080-6)
- McClung, D., and P. Schaerer. 2006. *The Avalanche Handbook*. The Mountaineers Books.
- McClung, D. M. 1996. Effects of temperature on fracture in dry slab avalanche release. *Journal of Geophysical Research-Solid Earth*, 101: 21907-21920. DOI: 10.1029/95jb03114
- National Avalanche Center. Encyclopedia. Retrieved 23 April 2016, from <http://www.fsavalanche.org/encyclopedia/>.
- Naturvårdsverket, 2014a. Att utreda relevansen och behovet av lavinprognoser för de svenska fjällen. Report 6641, Swedish environmental protection agency.
- Naturvårdsverket, 2014b. Offpiståkning – riskminimering eller riskacceptans?, Fjällsäkerhetsrådet, Report.
- Novák, V. 2005. Are fuzzy sets a reasonable tool for modeling vague phenomena? *Fuzzy Sets and Systems*, 156: 341-348. DOI: <http://dx.doi.org/10.1016/j.fss.2005.05.029>
- Osborn, G. 1982. Handbook of Snow: Principles, Processes, Management & Use, edited by DM Gray and DH Male. *Arctic*, 35: 346.
- Perla, R. 1977. Slab avalanche measurements. *Canadian Geotechnical Journal*, 14: 206-213.
- Perla, R., and M. Martinelli. 1976. *Avalanche Handbook, 2nd Revised Edition*. Forest Service Agriculture handbook: USDA.
- Pilesjö, P., and A. Hasan. 2014. A Triangular Form-based Multiple Flow Algorithm to Estimate Overland Flow Distribution and Accumulation on a Digital Elevation Model. *Transactions in Gis*, 18: 108-124. DOI: 10.1111/tgis.12015
- Savage, S. B., and K. Hutter. 1991. The dynamics of avalanches of antigranulocytes materials from initiation to runout .1. Analysis. *Acta Mechanica*, 86: 201-223. DOI: 10.1007/bf01175958
- Schneebeli, M., C. Pielmeier, and J. B. Johnson. 1999. Measuring snow microstructure and hardness using a high resolution penetrometer. *Cold Regions Science and Technology*, 30: 101-114. DOI: 10.1016/s0165-232x(99)00030-0
- Schweizer, J. 1999. Review of dry snow slab avalanche release. *Cold Regions Science and Technology*, 30: 43-57. DOI: 10.1016/s0165-232x(99)00025-7
- Schweizer, J., J. B. Jamieson, and M. Schneebeli. 2003. Snow avalanche formation. *Reviews of Geophysics*, 41: 25. DOI: 10.1029/2002rg000123
- Schweizer, J., K. Kronholm, J. B. Jamieson, and K. W. Birkeland. 2008. Review of spatial variability of snowpack properties and its importance for avalanche formation. *Cold Regions Science and Technology*, 51: 253-272. DOI: 10.1016/j.coldregions.2007.04.009
- Sjölander, S. 2004. Vindens och temperaturens förhållande till lavinaktiviteten på fjället Nuolja, Abisko. PhD Thesis Göteborgs Universitet
- SMHI. 2014. Lavinolyckor i Sverige. Retrieved 11 April 2016, from <http://www.smhi.se/kunskapsbanken/meteorologi/lavinolyckor-i-sverige-1.29251>.

- Statham, G., B. McMahon, and I. Tømm. 2007. The Avalanche Terrain Exposure Scale. eds. P. Canada, and C. A. Association.
- Strahler, A. N. 1957. Quantitative analysis of watershed geomorphology. *Eos, Transactions American Geophysical Union*, 38: 913-920.
- Sturm, M., J. Holmgren, M. König, and K. Morris. 1997. The thermal conductivity of seasonal snow. *Journal of Glaciology*, 43: 26-41.

## 8. Appendices

**Appendix 1:** The North American public avalanche danger scale, used in Sweden.

North American Public Avalanche Danger Scale				
Avalanche danger is determined by the likelihood, size and distribution of avalanches.				
Danger Level		Travel Advice	Likelihood of Avalanches	Avalanche Size and Distribution
<b>5 Extreme</b>		Avoid all avalanche terrain.	Natural and human-triggered avalanches certain.	Large to very large avalanches in many areas.
<b>4 High</b>		Very dangerous avalanche conditions. Travel in avalanche terrain <u>not</u> recommended.	Natural avalanches likely; human-triggered avalanches very likely.	Large avalanches in many areas; or very large avalanches in specific areas.
<b>3 Considerable</b>		Dangerous avalanche conditions. Careful snowpack evaluation, cautious route-finding and conservative decision-making essential.	Natural avalanches possible; human-triggered avalanches likely.	Small avalanches in many areas; or large avalanches in specific areas; or very large avalanches in isolated areas.
<b>2 Moderate</b>		Heightened avalanche conditions on specific terrain features. Evaluate snow and terrain carefully; identify features of concern.	Natural avalanches unlikely; human-triggered avalanches possible.	Small avalanches in specific areas; or large avalanches in isolated areas.
<b>1 Low</b>		Generally safe avalanche conditions. Watch for unstable snow on isolated terrain features.	Natural and human-triggered avalanches unlikely.	Small avalanches in isolated areas or extreme terrain.
Safe backcountry travel requires training and experience. You control your own risk by choosing where, when and how you travel.				

## Assessing Avalanche risk by terrain analysis

### Appendix 2: Documentation of past avalanches in Nuolja

Avalanche no	Date	Time	Location	Comment	Size (North American Danger Scale)	Aspect	Altitude (M.A.S.L.)	Inclination °	Type	N = Natural, S = Skier, X = Explosives		Reason
										Average Slab Width (m)	Average Slab Depth (cm)	
1	04/01/2002	night	Bullen	nedre	2	E			Slab	85	0.5	N
2	10/01/2002		Herr Melin		1				Slab	10	0.4	N
3	12/01/2002	night	Lavindalen		3.5				Slab	250	2.25	N
4	29/01/2002	11	Harbranten		1			45	Slab	10	0.1	S
5	31/01/2002	13	Branten	N lift	1	E	700	25	Slab	15	0.7	S
6	31/01/2002	12	Rihtunjira	N vindtunnel	1	E	800	30	Slab	10	0.3	S
7	04/02/2002		Näsan									N
8	04/02/2002		Rihtunjira	S sidan								N
9	04/02/2002		Rihtunjira	N sidan								N
10	14/02/2002	morning	Rihtunjira	Sweetspot								
11	18/02/2002	morning	Branten									
12	20/02/2002	morning	Branten									
13	23/02/2002	10	Branten	N lift	1	E	700	30	Slab	30	0.4	X
14	10/03/2002		Rihtunjira	sweetspot	3	E		45	Slab	100	0.45	X
15	25/03/2002	8	Bullen	Nedre	1	NE	750		Slab	10	0.1	S
16	25/03/2002	11	Vindtunneln		1.5	NE	850	40	Slab	35	0.3	S
17	28/03/2002		Branten	Nedfart	1	E			Slab	40	0.3	S
18	28/03/2002	morning	Rihtunjira	sweetspot	2	NE	845	48	Slab	40	0.4	S
19	29/03/2002		Rihtunjira	vindtunnel näsan	2.5				Slab			X
20	30/03/2002	14	Grytan	500m N linbana	3	NE	935	40	Slab	200	1.25	N
21	07/04/2002	10	Rihtunjira	sweetspot	1	NE	845	45	Slab	8	0.15	S
22	10/04/2002		Branten		1	E			Slab	40	0.2	S
23	11/04/2002		Branten		1	E			Slab	20	0.15	S
24	11/04/2002		Bullen	Övre	1				Slab	20	0.25	S
25	11/04/2002		Rihtunjira	vindtunnel	0.5				Slab	20	0.2	S
26	12/04/2002		Vindtunneln	Drivan från	2.5	NE	810		Slab	50		N
27	12/04/2002	9.45	Rihtunjira	vindtunnel	2	NE	810	48	Slab	30	0.7	X
28	12/04/2002	14.45	Vindtunneln	Drivan mot näsan	2	NE	810		Slab	30	0.7	X
29	12/04/2002	9.15	Rihtunjira	sweetspot	2	NE	800	36	Slab	40	0.3	X
30	13/04/2002		Herr Melin	Mynning N sidan	0.5	SE			Slab	8	0.1	S
31	13/04/2002		Amlert	Under telefonhyllan mot	0.5			50	Slab	20	0.1	S
32	13/04/2002		Bullen	S delen av nedre	0.5	SE			Slab	15	0.15	S
33	13/04/2002		Amlert		0.5	SE			Slab	5	0.15	S
34	14/04/2002	13.45	Grytan-Exteremen-Harbranten		3.5	E-NE	950	38.5	Slab	800	3.5	S
35	14/01/2003	11	Lilla Grytan	Nedfart	1	E-SE		35	Slab		0.65	S
36	16/01/2003	17.30	Rihtunjira	N Bullen, Grytan	1	NE		40	Slab			N
37	17/01/2003	13	Näsan	S lavindalen	1	E-NE			Slab			N
38	24/01/2003	9.30	Rihtunjira		1	SE	750		Slab			N
39	31/01/2003	12	Bullen	Nedre	0.5		700		Slab	5	0.15	S
40	16/02/2003	9.50	Konvexen		2	E	800		Slab	150		N
41	16/02/2003	9.50	Näsan		1	E	800		Slab	70		N
42	16/02/2003	9.50	Rihtunjira		1	E	800		Slab	70		N
43	16/02/2003	9.50	Branten	Drivan	0.5	E	800		Slab	10		N
44	18/02/2003	12	B3	200m nedan	0.5	E	850		Slab			N
45	08/03/2003	24	Näsan		0.5	SE	700		Slab	10		N
46	08/03/2003	24	Lavindalen		2	SE	800	45	Slab	100		N
47	08/03/2003	24	Extremen		1	E	800	45	Slab	20		N
48	08/03/2003	24	Branten						Slab	7	0.3	S
49	16/03/2003		Näsan		3	E-NE	800		Slab	150	1.75	N
50	17/03/2003	11.43	Bullen	Nedre	2	E	720		Slab			N
51	17/03/2003	morning	Lavindalen-Konvexen		3.5	E-SE	800		Slab	350	2	N
52	22/03/2003	24	Branten	Drivan S	2	E	750		Slab	15		N
53	22/03/2003	24	Rihtunjira	sweetspot	3	NE	800	45	Slab	50	1	N
54	23/03/2003	9	Bullen	Nedre mot hermelin	1	E-NE	750		Slab	15	0.4	S
55	04/23/2016		Skidområde		1	E-E		30	Slab	5	6.5	S
56	04/13/2016		Skidområde		1	E-NE			Slab	30	25	X
57	04/12/2016		Skidområde		1	E-NE			Slab	135	15	S
58	04/12/2016		Skidområde		1	SE-NE			Slab	100	12.5	S
59	04/11/2016		Skidområde		1	NE-N			Slab	20	17.5	S
60	03/29/2016	09:30	Skidområde		1	E	650	45	Slab	3	10	N
61	03/27/2016		Skidområde		1	NE-E			Slab	5.5	8.5	X
62	03/20/2016		Skidområde	1* sc övre bullen, 1*sc nedre bullen, 1*sc hermelin, vindflak från natten till 20/3	1	SE-E			Slab	4.5	5.5	S
63	03/18/2016		Skidområde		1.5	E			Slab			S
64	03/17/2016		Skidområde		1	E	650		Slab	6	10	S
65	03/12/2016		Skidområde		1	NE-E		35	Slab	15	10	S
66	02/29/2016	14:00	Skidområde	vindflak från nattens drevsnö. Endast övre lagret som släppte.	1	E-E	650		Slab	4.5	7.5	S
67	02/29/2016		Skidområde	vindflak från senaste nattens drev, endast översta lagret.	1	E-E	800		Slab	5.5	7.5	S
68	02/28/2016		Skidområde	Tunt flak i den snö som drevat in under dagen, Branta Långsvängen.	1	E	800	40	Slab	15	7	S

**Institutionen för naturgeografi och ekosystemvetenskap, Lunds Universitet.**

Student examensarbete (Seminarieuppsatser). Uppsatserna finns tillgängliga på institutionens geobibliotek, Sölvegatan 12, 223 62 LUND. Serien startade 1985. Hela listan och själva uppsatserna är även tillgängliga på LUP student papers (<https://lup.lub.lu.se/student-papers/search/>) och via Geobiblioteket ([www.geobib.lu.se](http://www.geobib.lu.se))

The student thesis reports are available at the Geo-Library, Department of Physical Geography and Ecosystem Science, University of Lund, Sölvegatan 12, S-223 62 Lund, Sweden. Report series started 1985. The complete list and electronic versions are also electronic available at the LUP student papers (<https://lup.lub.lu.se/student-papers/search/>) and through the Geo-library ([www.geobib.lu.se](http://www.geobib.lu.se))

- 350 Mihaela – Mariana Tudoran (2015) Occurrences of insect outbreaks in Sweden in relation to climatic parameters since 1850
- 351 Maria Gatzouras (2015) Assessment of trampling impact in Icelandic natural areas in experimental plots with focus on image analysis of digital photographs
- 352 Gustav Wallner (2015) Estimating and evaluating GPP in the Sahel using MSG/SEVIRI and MODIS satellite data
- 353 Luisa Teixeira (2015) Exploring the relationships between biodiversity and benthic habitat in the Primeiras and Segundas Protected Area, Mozambique
- 354 Iris Behrens & Linn Gardell (2015) Water quality in Apac-, Mbale- & Lira district, Uganda - A field study evaluating problems and suitable solutions
- 355 Viktoria Björklund (2015) Water quality in rivers affected by urbanization: A Case Study in Minas Gerais, Brazil
- 356 Tara Mellquist (2015) Hållbar dagvattenhantering i Stockholms stad - En riskhanteringsanalys med avseende på långsiktig hållbarhet av Stockholms stads dagvattenhantering i urban miljö
- 357 Jenny Hansson (2015) Trafikrelaterade luftföroreningar vid förskolor – En studie om kvävedioxidhalter vid förskolor i Malmö
- 358 Laura Reinelt (2015) Modelling vegetation dynamics and carbon fluxes in a high Arctic mire
- 359 Emelie Linnéa Graham (2015) Atmospheric reactivity of cyclic ethers of relevance to biofuel combustion
- 360 Filippo Gualla (2015) Sun position and PV panels: a model to determine the best orientation
- 361 Joakim Lindberg (2015) Locating potential flood areas in an urban environment using remote sensing and GIS, case study Lund, Sweden
- 362 Georgios-Konstantinos Lagkas (2015) Analysis of NDVI variation and snowmelt around Zackenberg station, Greenland with comparison of ground data and remote sensing.
- 363 Carlos Arellano (2015) Production and Biodegradability of Dissolved Organic Carbon from Different Litter Sources
- 364 Sofia Valentin (2015) Do-It-Yourself Helium Balloon Aerial Photography - Developing a method in an agroforestry plantation, Lao PDR
- 365 Shirin Danephash (2015) Evaluation of Standards and Techniques for Retrieval of Geospatial Raster Data - A study for the ICOS Carbon Portal
- 366 Linnea Jonsson (2015) Evaluation of pixel based and object based classification

- methods for land cover mapping with high spatial resolution satellite imagery, in the Amazonas, Brazil.
- 367 Johan Westin (2015) Quantification of a continuous-cover forest in Sweden using remote sensing techniques
- 368 Dahlia Mudzaffar Ali (2015) Quantifying Terrain Factor Using GIS Applications for Real Estate Property Valuation
- 369 Ulrika Belsing (2015) The survival of moth larvae feeding on different plant species in northern Fennoscandia
- 370 Isabella Grönfeldt (2015) Snow and sea ice temperature profiles from satellite data and ice mass balance buoys
- 371 Karolina D. Pantazatou (2015) Issues of Geographic Context Variable Calculation Methods applied at different Geographic Levels in Spatial Historical Demographic Research -A case study over four parishes in Southern Sweden
- 372 Andreas Dahlbom (2016) The impact of permafrost degradation on methane fluxes - a field study in Abisko
- 373 Hanna Modin (2016) Higher temperatures increase nutrient availability in the High Arctic, causing elevated competitive pressure and a decline in *Papaver radicum*
- 374 Elsa Lindevall (2016) Assessment of the relationship between the Photochemical Reflectance Index and Light Use Efficiency: A study of its seasonal and diurnal variation in a sub-arctic birch forest, Abisko, Sweden
- 375 Henrik Hagelin and Matthieu Cluzel (2016) Applying FARSITE and Prometheus on the Västmanland Fire, Sweden (2014): Fire Growth Simulation as a Measure Against Forest Fire Spread – A Model Suitability Study –
- 376 Pontus Cederholm (2016) Californian Drought: The Processes and Factors Controlling the 2011-2016 Drought and Winter Precipitation in California
- 377 Johannes Loer (2016) Modelling nitrogen balance in two Southern Swedish spruce plantations
- 378 Hanna Angel (2016) Water and carbon footprints of mining and producing Cu, Mg and Zn: A comparative study of primary and secondary sources
- 379 Gusten Brodin (2016) Organic farming's role in adaptation to and mitigation of climate change - an overview of ecological resilience and a model case study
- 380 Verånika Trollblad (2016) Odling av Cucumis Sativus L. med aska från träd som näringstillägg i ett urinbaserat hydroponiskt system
- 381 Susanne De Bourg (2016) Tillväxteffekter för andra generationens granskog efter tidigare genomförd kalkning
- 382 Katarina Crafoord (2016) Placering av energiskog i Sverige - en GIS analys
- 383 Simon Nåfält (2016) Assessing avalanche risk by terrain analysis – An experimental GIS-approach to the Avalanche Terrain Exposure Scale (ATES)