

Antenna design, manufacture and testing

Constantine Ayimba, *Department of Electrical and Information Technology, Lund Unviveristy*

Abstract—Patch or planar antennae have become increasingly popular for use in many applications as they are cheap to manufacture and can be easily incorporated into the circuitry of many devices.

This work explores the processes required to produce reliable planar antennae. Designs of antennae are simulated using specialised software to predict their behaviour. The best performing designs are then supplied to a laser milling machine for manufacture. Measurements on the manufactured antennae are compared with initial predictions to assess the dependability of the processes and make recommendations.

I. INTRODUCTION

A conversation can be viewed as a rudimentary wireless communication system. Thoughts are transformed into words which are then voiced from the speakers mouth and are transferred as sound waves to the listeners ear.

In radio communication systems, antennae take the place of the mouth and ears in a human conversation. Electrical signals are transformed into electromagnetic waves by the transmitting antenna and are then transferred over the air to the receiving antenna. The receiving antenna transforms the incoming waves back into electrical signals as shown in Figure 1.

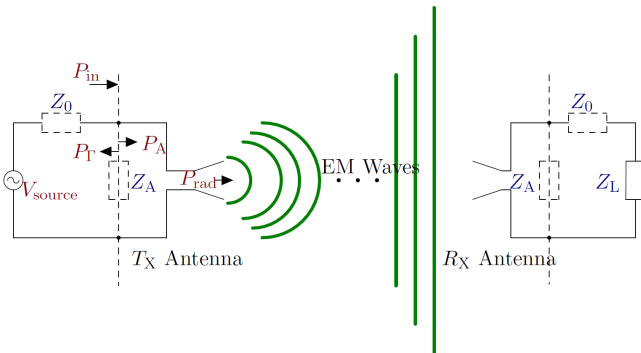

Fig. 1. Schematic of a radio communication system

II. DESIGN AND MANUFACTURE

Planar antennae are typically made from pre-fabricated circuit boards consisting of a base material sandwiched between two thin layers of copper. Typically, one of these layers is formed into a particular antenna shape by etching away excess copper as shown in Figure 2. The dimensions of the shape determine the frequency range of operation.

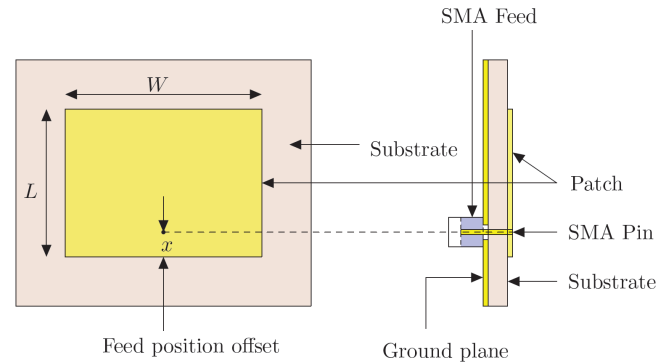

Fig. 2. Typical structure of a planar antenna

A properly designed antenna at the sending end should be able to convert most of the electrical energy it receives into electromagnetic waves in order to enhance the chances of the signal being recovered at the receiving end. The antenna at the receiving end should be designed to respond to the weakest possible signal at the proper frequency.

A good indicator of the ability of an antenna to perform either function is how much of the energy delivered to it is lost owing to reflections. The lower this value is, the better the antenna performs.

Once the physical model of the antenna has been determined, adjustments to its dimensions can then be made using specialised software in order to improve its performance at the desired frequencies. These programs perform simulations based on classical electromagnetic formulae and the structure of the antenna to determine its characteristics.

Once the optimal characteristics are attained, the resulting designs are supplied to the milling machine shown in Figure 3 for fabrication. An example of a fabricated antenna is shown in Figure 4.

III. ANTENNA TESTING

Once the antenna has been fabricated, its electrical properties are measured using the precision instrument shown in Figure 5. The measurements determine how much energy it loses due to reflection over a given range of frequencies.

A typical measurement result is depicted in Figure 6. Disparities between the measured and simulated responses are often observed. In such cases, it is important to adjust the electrical properties of the base material so that subsequent simulations are as close as possible to the actual measured responses. The design process is then repeated with the updated material properties to produce better antennae at the design frequencies.

C. Ayimba is a candidate for an MSc. in Wireless Communications from LTH, Lund University, Sweden

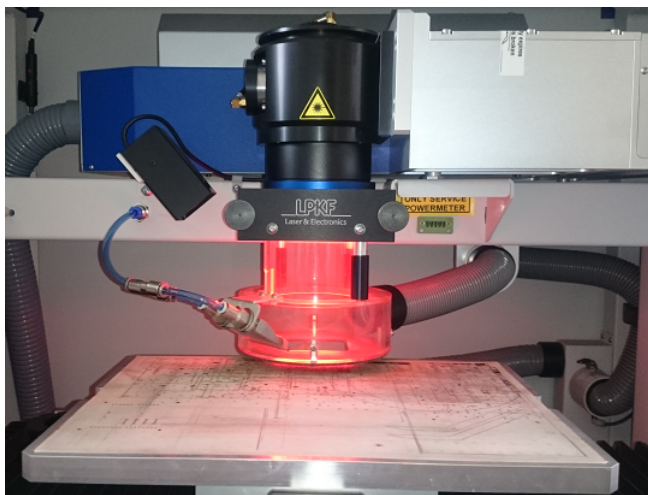

Fig. 3. Laser milling machine

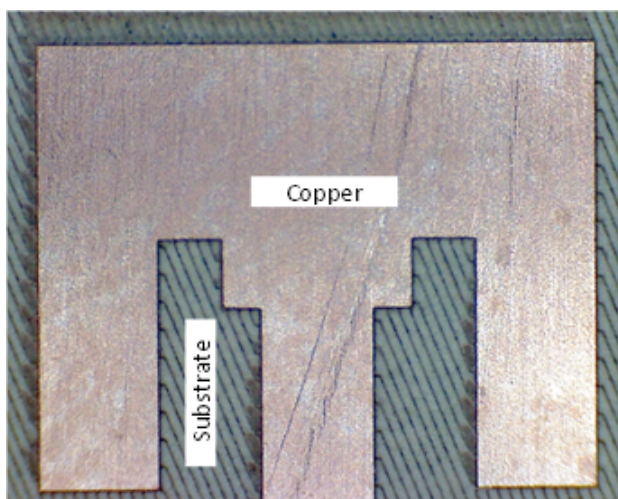

Fig. 4. Manufactured antenna

IV. CONCLUSION

The properties of the base material as represented in the simulation software are found to have the greatest influence on how well the manufactured antenna's responses correspond to those obtained during its design. The more accurately these parameters are represented, the more reliable the simulations are when compared to actual measurements. Fabrication errors are found to be minimal pointing to high accuracy of the laser milling process.

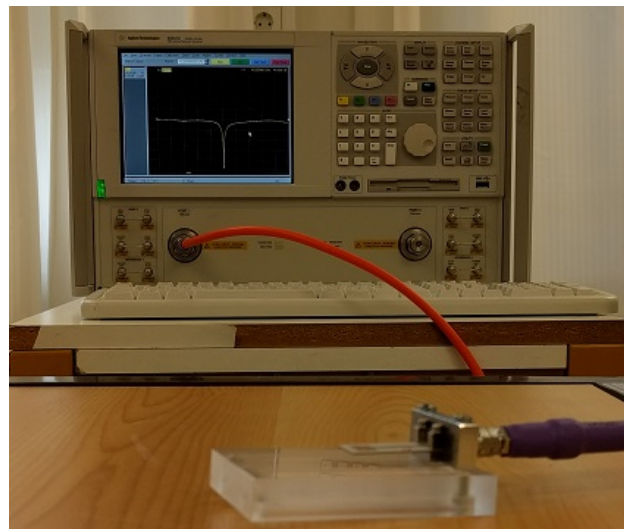

Fig. 5. Vector Network Analyser measurement setup

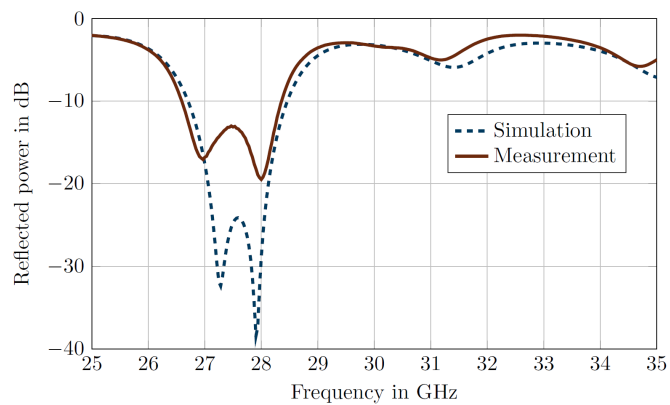

Fig. 6. Antenna measurement result. Below -10dB, the disparity between the graphs is not considered important.