

Versatile Test Rig

**Further development of a test rig for
pneumatic brake valves**



Sherjeel Ton

Division of Industrial Electrical Engineering and Automation
Faculty of Engineering, Lund University

Versatile Test Rig

Further development of a test rig for pneumatic
brake valves

Sherjeel Ton

6/3/2013

Abstract

This report is about further development of a test rig called the Delhi Metro Rail Corporation Test Rig, called the DMRC Test Rig. A method for testing pneumatic valves, used in the systems for train brakes and called brake valves, was developed. The main objective was to automatize the testing of all existing and future developed pneumatic brake valves, made by the company Faiveley Transport, using the DMRC Test Rig. The project was kept at a low cost and with the least modifications to the DMRC Test Rig possible.

In the development process all the DMRC Test Rig components and every pneumatic brake valve was studied so that concepts could be generated. When the final concept was chosen together with the Research & Development team, the execution started. A complete new Ladder code was written for the Mitsubishi PLC system to run and test the pneumatic brake valves. Also a whole new Java code was written to support the RS-232 communication between the Windows XP based PC and the Mitsubishi PLC system, which is used for operating the DMRC Test Rig and storing the captured data.

At the end of the project the single port relay valve was tested using the DMRC Test Rig and both the valve and the rig showed good results. The DMRC Test Rig proved to make the performance test 60 times faster than the original test rig. Also the endurance test showed interesting and useful results even when there was not enough time to perform all the cycles required. This report covers the whole product development process from studying the DMRC Test Rig components to testing the valve. The report can be used for future developers.

Abstract.....	2-1
1.1 Background	2-4
1.2 Motivation.....	2-4
1.3 Objective	2-5
1.4 Scope.....	2-5
1.5 Important Notice.....	2-5
2 Required Theory.....	2-6
2.1 Pneumatic & Fluid Mechanics.....	2-6
2.2 Mechanics	2-6
2.3 Electronics/ Computer Science	2-6
2.4 Product Development and Design Methodology	2-7
3 The Original, existing DMRC Test Rig Components	3-8
3.1 Mitsubishi PLC.....	3-9
3.2 Pneumatic	3-13
3.3 Other Components	3-15
3.4 Developed Hardware by Faiveley Transport.....	3-16
3.5 Pneumatic Schematic.....	3-17
3.6 Electrical Schematic	3-18
4 Software Development	4-19
4.1 User Interface.....	4-19
4.2 RS-232 Communication.....	4-21
4.3 Java.....	4-22
4.4 PLC Ladder.....	4-26
5 Current Testing Methods	5-32
5.1 Endurance Test	5-32
5.2 Performance & Leak Test.....	5-34
6 Pneumatic Brake Valves for Testing	6-35
6.1 Brake Valves	6-35
7 Generating Concepts	7-58
7.1 Concept 1	7-59
7.2 Concept 2	7-60
7.3 Concept 3	7-61

7.4	Concept 4	7-61
8	Improving and Choosing Concept	8-62
8.1	Concept 1	8-62
8.2	Concept 2	8-62
8.3	Concept 3 and Concept 4 Combined	8-62
8.4	Choosing Concept	8-63
9	The new DMRC Test Rig Build	9-64
9.1	Pneumatic Schematic.....	9-64
9.2	Adding New Valves	9-64
10	Testing of Single Port Relay Valve	10-65
10.1	Tests	10-65
10.2	Connection/Assembly/Schematics	10-66
10.3	Captured Data	10-67
10.4	Analysis of Data.....	10-67
10.5	Conclusion.....	10-69
10.6	Discussion.....	10-69
11	Further Development.....	11-71
11.1	Valve Mounting Device	11-71
11.2	Features	11-71
11.3	RS-232 & Ladder code.....	11-72
11.4	User Interface.....	11-72
11.5	Adding more Valves	11-72
12	Bibliography	12-73
	Appendix A Schematics	A-1
	Appendix B New Schematic	B-4
	Appendix C Captured data during testing of Single Port Relay Valve.....	C-6
	Appendix D Calculations	D-9

Introduction

Faiveley Transport Railway Technologies is an international company with headquarter in Paris. They are manufacturer and supplier of railway equipment. The division in Hosur, India has approximately 300 employees. That is also where this project, Versatile Test Rig, is taking place. Faiveley Transport in Hosur, India is mainly producing and developing train doors, ventilation systems and pneumatic valves. It is a fast growing company where the product quantities are increasing.

1.1 Background

In the late 90s Faiveley Transport in Hosur, India bought a test rig from the Russian company Ajana. The test rig, called the Delhi Metro Rail Cooperation Test Rig or the DMRC Test Rig, was used in the Delhi Metro Rail Cooperation project to perform tests on the complete train brake systems.

A complete train brake system consists of different types of pneumatic valves, called brake valves. Before testing the complete brake system the brake valves have to be tested individually in other existing test rigs.

There are several types of tests which all brake valves have to undergo before they can be assembled into the complete brake system. The focus in this project, Versatile Test Rig, lies in the main three tests: endurance, performance and the leak test.

The purpose with the endurance tests is to make sure that the valves last long enough for their task. Performance test is to make sure that the valves are working properly and delivering the right values, for example the right pressure or the right volume flow. In the leak test the valves are tested against air leakages. These tests should resemble the reality as much as possible to prevent malfunctions during its use.

1.2 Motivation

Having a variety of tests and many different test rigs takes up a lot of space and time. It is also confusing for the labor, especially when the rigs are manual and semi-automatic. Developing a test rig which can perform all the tests on all the valves, completely automatically, would make the whole test process much faster, easier and cheaper. Less labor would be needed, space would be saved and the captured data from the tests can be stored digitally which it is not being done today. By storing the data, the company can use the information for example to benchmark the valves against competitors and also to improve their own product.

1.3 Objective

The objective of this project is to modify the DMRC Test Rig to make the rig possible to test existing and future developed brake valves made by Faiveley Transport. If this is possible the objectives presented below are next to be taken into consideration.

- Find ways to modify the construction, pneumatics, electronics and programming of the DMRC Test Rig to make it possible to perform leak, performance and endurance tests on as many brake valves as possible.
- Program it in such a way it is easy to add new valves to the Ladder and Java code for the testing.
- Program the Mitsubishi PLC system in such a way that it is easy for future developers to understand and further develop the DMRC Test Rig.
- Make the DMRC Test Rig fully automatic and add the possibility to save the data from every test.
- Make an interface based on C/C++ on a PC with Windows XP.
- Operate the DMRC Test Rig by RS-232 from a Windows XP based computer.
- Keep it at a low cost with the least modification possible.

1.4 Scope

The target of this thesis is to meet all the objectives in the project and to make the system run. There are many things that have to be taken into consideration during the development and the project is relatively big for one person. That will make it difficult to achieve all the objectives and it might not be achieved at all.

1.5 Important Notice

The unit used for pressure in this report is [bar]. The pressure at sea level is equal to 1 atm or 1.01325 bar. At Faiveley Transport in Hosur India they are using 0 bar as reference for the pressure at sea level. This reference will be used in this report as well to avoid misunderstandings with Faiveley Transport.

Faiveley Transport is currently using British Standard Pipe (BSP) for all threads on pneumatic tubes and other types of pneumatic connections related to pneumatic brake valves in this project.

2 Required Theory

An engineer specialized in only one field, for example an electrical engineer, would have a hard time doing this project alone because the DMRC Test Rig contains parts within the electrical, mechanical and software fields. Mechatronic engineers have knowledge within all these fields which makes them suitable for this task.

2.1 Pneumatic & Fluid Mechanics

Having some knowledge in pneumatics and fluid mechanics will speed up the study phase of the project. It makes it possible to quickly understand how most of the valves are functioning just by looking at the pneumatic symbols. It also eases the reading of the schematics which makes it possible to understand how the pneumatic arrangement can be controlled and what limitations it has. For example the Extended Bernoullis Equation from fluid mechanics gives an idea of how the pressure and airflow is controlled by physical parameters. Later in the process this knowledge will be used to determine if and how the valves can be tested.

Most of the information was taken from (1).

2.2 Mechanics

Basic knowledge in mechanics is required to be able to understand the technical design of the valves. The DMRC Test Rig cannot test every valve in the same way as it is being done today. The test methods of some valves need to be changed to fit into the DMRC Test Rig. Studying the construction of each valve helps finding a possible solution to test the valves differently and also their limitations.

2.3 Electronics/ Computer Science

It is required to know the basics of electronics to be able to understand the electrical parts of the DMRC Test Rig. The most important part is to know how a relay works, how to read electrical schematics and how to follow up wires stated in schematic. It is also necessary to have a logical understanding of how the physical wires are connected to the PLC, with regard to the Ladder programing.

To start programming the PLC system with Ladder code it is necessary to know the basics of the programming language. Mitsubishi provided the PLC system so most of the programming functions are in the datasheets given by Mitsubishi. Each of the PLC modules has its own datasheet. Most of the module functions are well explained in the datasheet and relatively easy to understand.

To manage the serial communication between the PLC and the PC it is required to know Java programming. The objective was to do the programming in C/C++ but this was later changed to Java due to a particular reason which is explained later in the report. Java is a relatively easy and safe programming language which can be used by many and was therefore chosen. The main Java functions used is the concurrent programming with threads and also the Serial Communication with RS-232 for Java.

2.4 Product Development and Design Methodology

Most of the product development methodologies used in the process was taken from (2). It was useful and it also gave a good approximation on how to begin the project. Despite this only a part of the methodology was applied due to some reasons, such as time, costs and modification restrictions to the DMRC Test Rig.

3 The Original DMRC Test Rig Components

This chapter describes the product specifications and purposes of the installed hardware. These are the pneumatic components and the PLC modules. There is barely any information or datasheets for the components in the DMRC Test Rig. To get this information the ID has to be located for every component so the documentation for each of the components can be searched for and downloaded from the Internet.

The modules limit the number of valves, pressure regulators which can be controlled and also the number of pressure transducer which can be installed. The valves, installed in the DMRC Test rig, will then control the amount of brake valves which can be tested. Therefore it is important to get the right product specifications for each of the modules for the development.



Figure 1. The DMRC Test Rig.

3.1 Mitsubishi PLC

The PLC system was bought from Mitsubishi Electric which is a well-known company in the PLC market. The abbreviation PLC stands for Programmable Logic Controller. It is a digital computer used for automation of electromechanical processes, for example to automatize the testing of pneumatic valves. This PLC runs with Ladder code which is written by a user on a PC. Datasheets and other information can be found on the company website.

Software called GX Developer is provided with the PLC system. The software is used for writing the Ladder code, setting up the module specifications, debug and manually run the system. The program is also used for loading the Ladder code into the PLC system using USB or the RS-232 port. The code will then be stored in a battery backed up memory. The PLC system consists of the modules shown in Figure 2. These modules are connected to a 12 slot base rack. Each of the modules has one or more specific datasheets which explains the specifications and the functions of the modules. But only the relevant and useful information will be brought up in this chapter. For more information about Mitsubishi PLC modules, see datasheets mentioned in each subsection.

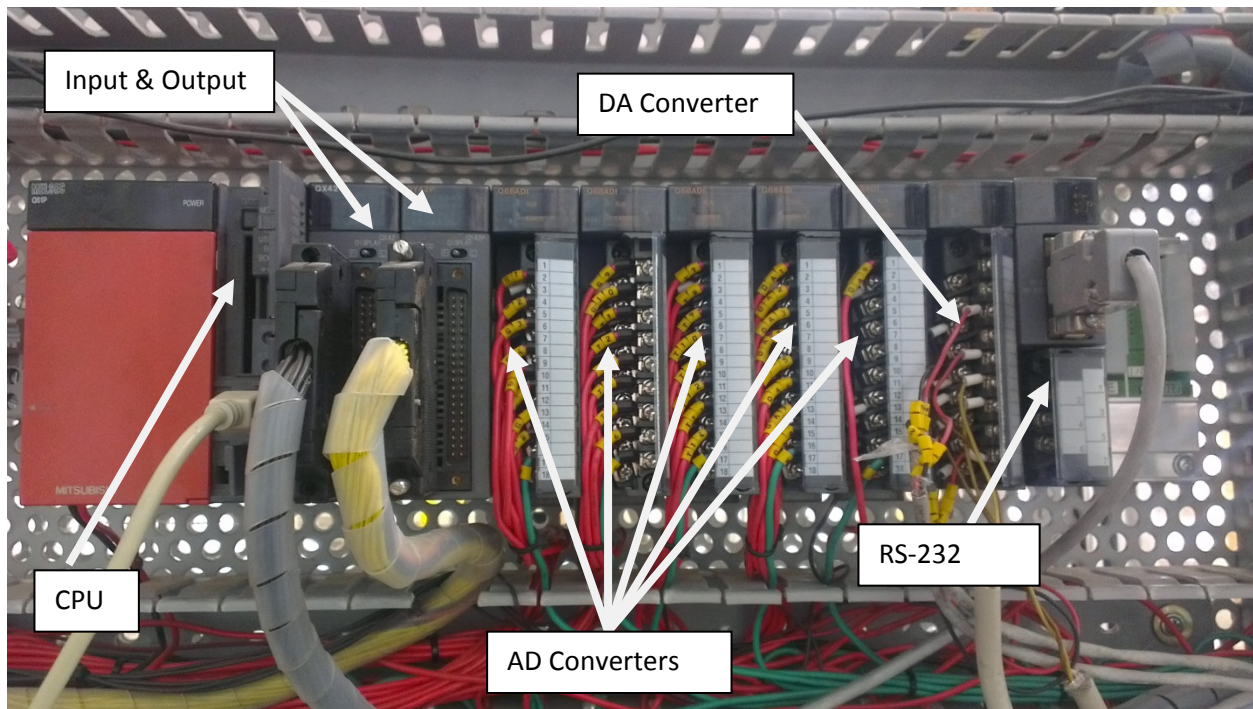

Figure 2. PLC modules.

3.1.1 Analog to Digital Converter Module (Q68ADI)

The Q68ADI module is an analog to digital, 8 channels converter. There are five of these modules connected to the base rack. The module is used for converting analog signals, from the transducers, to digital. 10 fixed transducers, G1- G10 referred to the pneumatic schematic in Appendix A, are connected to the first A/D module and are used for valve testing purposes. 4 – 20 mA and normal resolution mode has been chosen which means 4 mA input will return 0 and 20 mA will return 4000 digital, the last 95

out of the 4095 decimals in the buffer are not being used. There are two ways to convert the analog signals, *Sampling Processing* and *Average Processing*, these are described below.

1. *Sampling Processing*: The A/D conversion is performed successively for the analog input.
2. *Average Processing*:
 - *Average amount of time*: The average value is calculated from the sum of values excluding maximum and minimum. The number of processing repetitions is limited by the set time. The average value is then calculated and stored in the buffer.
 - *Average set number of times*: The average value is calculated after it has performed a predefined number of processing repetitions.

Choosing “Sampling processing” will make the converted value update too frequent and on every slight pressure change. Choosing this option will lead to never having a stable pressure value in any of the transducers. Instead the value will seem to vary within an unknown range, for example if the pressure regulator is set to 2 bar and the air inside the reservoir is 2 bar and then the valve to the reservoir is shut. The transducer which measures the pressure inside the reservoir should have the same value every time it updates, unless the pressure changes which is not occurring. Instead the measured pressure value varies, for example in the range of 795 – 805. This range is unknown and can be experienced as random. This phenomenon was not studied closer but it was probably caused by oscillation by the transducers.

Because of this phenomenon it is difficult to determine when the right pressure is achieved. Due to this reason “Average processing” was chosen which gave a steady average value. There were no advantages to know the exact number of times of processing repetition, therefore “Average number of times” was not necessary. It is easier to control the total time than to control the number of repetitions because the time for one repetition is unknown and has to be calculated.

Figure 3 is presenting the Q68ADI module. For more information about the module, see (3).



Figure 3. A/D module.

3.1.2 Digital to Analog Converter Module (Q68DAV)

The Q68DAV module is a digital to analog converter with 8 channels. There is one module installed in the PLC system, where 4 out of 8 channels are being used for controlling the pressure regulators. Each channel has three different options for the output range where 4 – 20 mA is chosen with normal resolution mode. This means that 0-4095 input data will return 4 – 20 mA on output channel. The last 95 out of the 4095 decimals in the buffer is not being used.

For more information about the module and how to program it, see (4). Figure 6 presents the Q68DAV module.

3.1.3 Central Processing Unit module (Q02HCPU)

The Q02HCPU can handle a maximum of 4096 I/O points on the modules connected to the base rack (X/Y0 to FFF). The number of device points usable in the program is 8192 points (X/Y0 to 1FFF). Figure 4 shows the CPU module. More information regarding this CPU is available in (5) and (6).



Figure 4. Q02HCPU module.

3.1.4 DRP-480-24

Figure 5 shows the power supply with 100-240V AC Input and 5V DC 3A or 24V DC 0.6A Output.



Figure 5. Power supply.

3.1.5 Input Module (QX42)

The QX42 input module has 64 Input signals which can be used as relays in the Ladder code. The module will not be described any further because it is not used in this project.

3.1.6 Output Module (QY42P)

The QY42P output module has 64 output signals which are connected to external relays by wires. These output signals coming from the output module are triggered inside the Ladder code and used for controlling the valves together with the relays and a power supply. There is one module installed in the base rack. More detailed information about this module is available in (7).

3.1.7 RS-232 Module (QJ71C24)

The QJ71C24 module is used for establishing a RS-232 communication between an external device and the PLC system, for example it is possible to transmit data to the PLC and operate the rig by this port. It is also possible to go the other way and send data from the PLC to the PC or any other external device. This module is used for controlling the rig and to store the captured data on the PC hard drive.

It supports many different communication methods and allows many settings. It is too complex to explain everything here. All the features and how to program this module are explained in the datasheets. For more information about features and how to program it, see (8) and (9). Figure 6 shows the MQJ71C24 serial communication module.

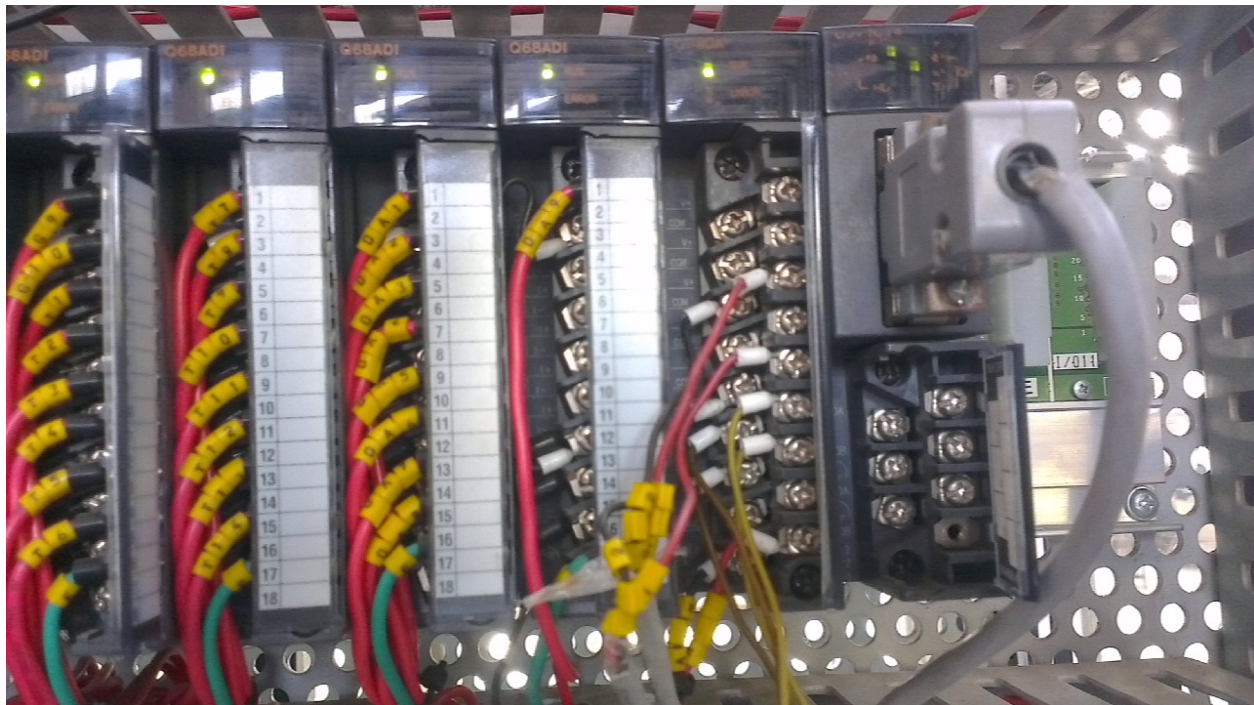

Figure 6. A/D, D/A & Serial module.

3.2 Pneumatic

All the relevant and important pneumatic parts in the DMRC Test Rig are described in this chapter. The information is taken from the documents and the datasheets which had to be searched for on the web, except for the transducer which was provided.

There is a slight deviation between the pneumatic connections in the rig and the pneumatic schematic. On the physical rig there are some additional tubes and connections which are missing in the schematic. There is no documentation supporting this change. Later on it was discovered that this mismatching was caused by several valve changes in the rig. To control these new valves additional control air was required. This led to extra tubes being installed in the rig but the functionality still remains the same.

3.2.1 Transducers ver. 8293.78.2517/8293.79.2517

The specifications made for the transducers were given by Faiveley Transport and manufactured by another company. These are used for measuring the pressures in the different lines in the DMRC Test Rig. They return values as analog signals in the range of 4 – 20 mA. A/D converters are being used to convert these signals into digital. Each transducer occupies one channel on the A/D converter module.

The measuring range which the transducer can handle is 0 – 10 bar for model .78 and 0-16 bar for model .79. These transducers have a typical accuracy of 0.5% at 25°C but it will vary depending on the temperature, see Figure 7 which is taken from (10). Due to temperature changes in Hosur, India an accuracy of 1% should be used if the tests are running during days and nights. This accuracy is not enough for certain valves which will be stated under valve descriptions in Chapter 6, the calculations are presented in Appendix D.

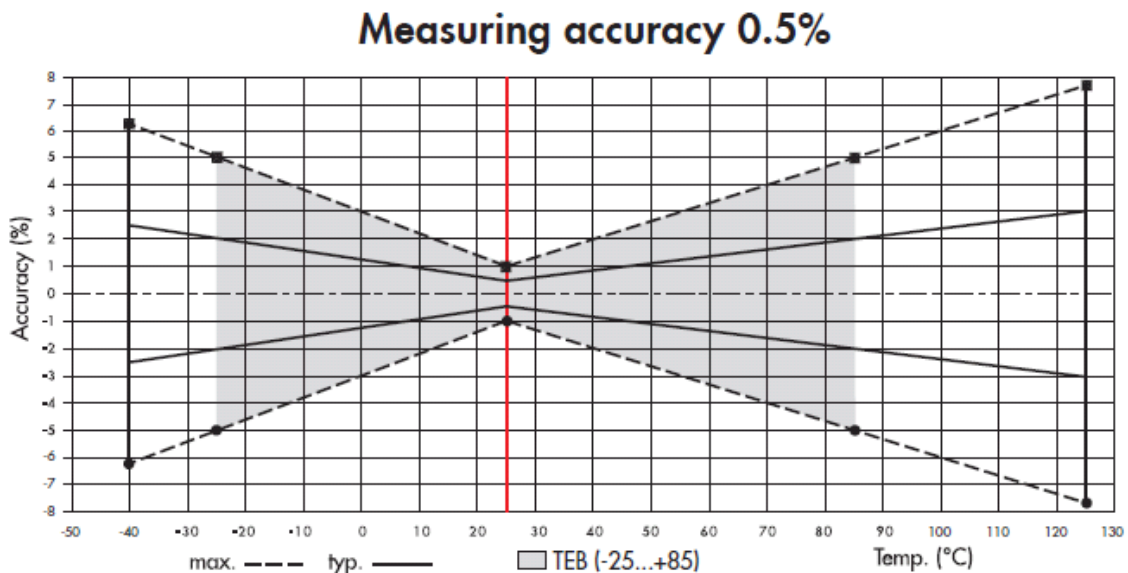

Figure 7. Measuring accuracy for transducer 8293.78.2517 and 8293.79.2517.

Figure 8 shows one of the transducers which is installed in the DMRC Test Rig. The G7 note on the figure refers to transducer G7 on the pneumatic schematic.



Figure 8. Transducer.

3.2.2 Pressure Regulators, MPPE-3-1/2-10 010-B

The pressure regulator regulates the pressure in the DMRC Test Rig. These pressure regulators are controlled by analog signals between 0-10 V. Depending on the voltage, the pressure will vary between 0-10 bar. The DMRC Test Rig has 4 pressure regulators of type MPPE-3-1/2-10 010-B made by Festo. Each pressure regulator occupies a channel on the D/A module for controlling purposes. They are designed for ½” connections but for some reason the tubes connected are 1”, which is odd because the pressure regulator will restrict the diameter of the air flow down to ½”. Figure 9 shows one of the pressure regulators which is installed in the DMRC Test Rig. “R3” marked on the pressure regulator refers to pressure regulator “R3” on the pneumatic schematic presented in Appendix A.



Figure 9. Pressure Regulator.

3.2.3 2/2 Valve / Cocks

These cocks with the size 1" are used for shutting the air flow. Unfortunately they have a small leak. The leak does not interfere with the endurance or the performance test but it will make the leak tests difficult or impossible to perform. Figure 10 shows one of the cocks installed in the DMRC Test Rig. The brownish part on the figure is the physical cock and the black part marked with "C1" is the electrical device for controlling purposes. "C1" refers to the cock "C1" on the pneumatic schematic presented in Appendix A.

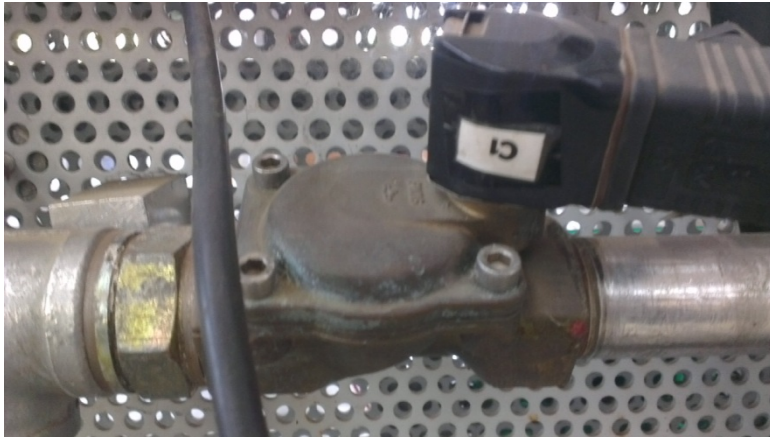

Figure 10. Cocks.

3.3 Other Components

The rig contains many other components than those mentioned above, for example tubes, reservoirs, manifolds. The tube sizes are all stated in the pneumatic schematic presented in Appendix A . They vary between ¼" to 1" depending on which line it is, for example inlet has a 1" tube connected because it is important that there are no restrictions in that line. There are also a couple of reservoirs with different sizes which is stated in the pneumatic schematic. However in the pneumatic schematic there is a 100 L reservoir which does not exist.

Figure 11 shows some tubes connected to the old leak test manifold. The small openings in the vertical beam are where the air exits when the leak test was running in the old DMRC project.



Figure 11. Old leak test manifold.

There are 2x 20L, 1x 10L, 2x 5L and 1x 3L Reservoirs installed in the rig as stated in the pneumatic schematic presented in Appendix A. Figure 12 and Figure 13 shows the 10 and 5 liters reservoirs which are being used in the tests of a single port relay valve. In that test the 10 liter is used as inlet and the 5 liter as outlet.



Figure 12. 10 liter reservoir.



Figure 13. 5 liter reservoir.

3.4 Developed Hardware by Faiveley Transport

Some parts of the DMRC Test Rig have been changed by Faiveley Transport. Most of the changes have not been documented and had to be figured out during this project. In the following subsections the changes done to the DMRC Test Rig and made by Faiveley Transport are clarified.

3.4.1 Angle Seat Valve – Double Acting by Rotex

The DMRC Test Rig contains a number of 2/2 bidirectional valves which replaced the original cocks because they were leaking. They are used for controlling the air flow, for example to stop it from entering the reservoirs. These valves have a constant air pressure applied to the valve be able to function properly and are controlled with the PLC. This information has been added here because there are no other supporting documents for this change. Figure 14 shows one of the angle seat valve installed in the DMRC Test Rig. The white note with the text “C5” on the figure refers to the valve “C5” in the pneumatic schematic presented in Appendix A. The blue tube contains pressurized air, used for controlling the valve together with the electrical parts, which are the black components in the figure.

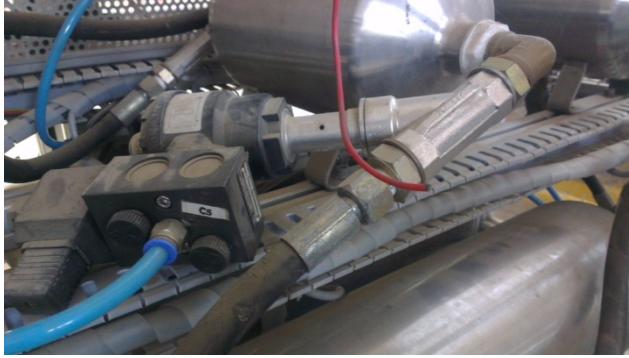

Figure 14. Angle Seat Valve.

3.5 Pneumatic Schematic

Figure 15 is a thumbnail of the pneumatic schematic. This is the original and the only schematic of the DMRC Test Rig. As it was mentioned above some cocks have been changed to Angle Seat Valves. These valves require air pressure to function and these tubes have not been added to the schematic. The decision not to make a new schematic was made because of time lacking and the small change. Another important notice is the 100L tank which does not exist. Otherwise the functionality still remains the same and is not affected.

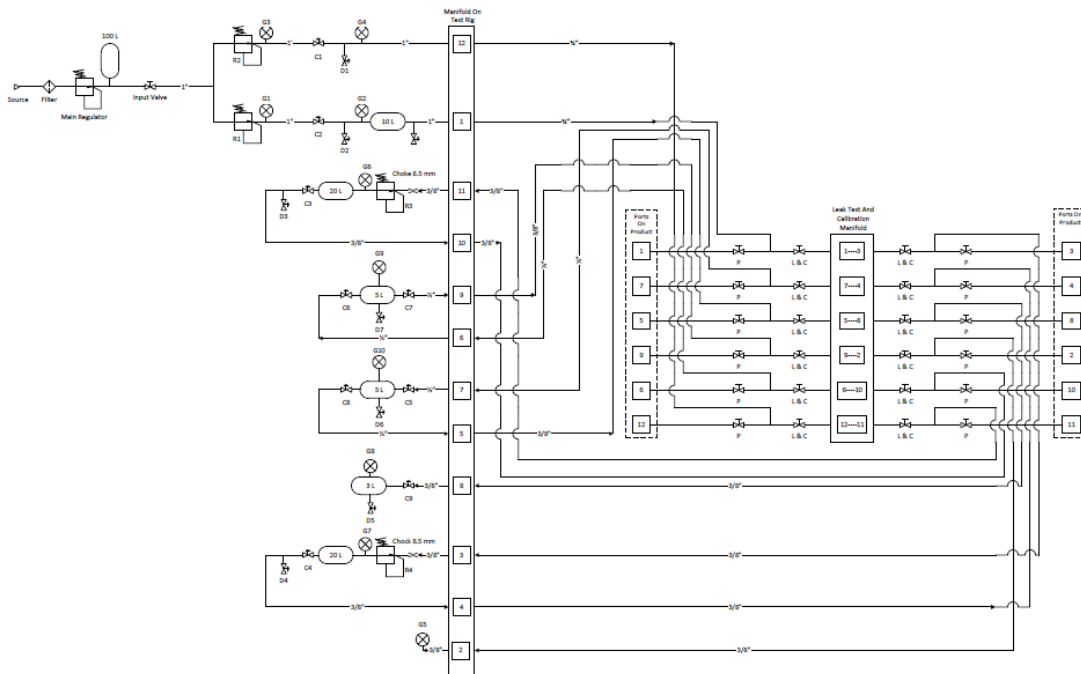

Figure 15. Pneumatic schematic of the DMRC Test Rig.

3.6 Electrical Schematic

The electrical schematic is presented in Appendix A. Many wires and connections had to be investigated in the physical rig because the electrical schematic does not show everything. The following descriptions are made to ease the understanding of the schematic.

The PLC ports 0 and 1 on the electrical schematic are the port names for all connections on the output module. These are then connected to relays for controlling the cocks and exhaust valves which are stated as C1 – C9 and D1 – D9 on the pneumatic schematic. Unfortunately the schematic, both pneumatic and the electrical, does not say which connections on the output module is connected to which cock or exhaust valves. To get this information, wires and connections have to be traced in the rig. All the wires have tags and these tags can be matched together with ports on the output module, for example the Y49 connection on the Output module is equal to C1 after matching the tags on the lines.

PLC Ports 2 and 3 on the schematic are the ports of all the connections on the A/D module which are connected to transducers G1 – G10. Unfortunately there is no information on the electrical schematic to tell which port goes to which transducers. After some studies of the physical DMRC Test Rig the following conclusion could be made. G1 - G8 are connected to the first A/D Converter, channel 1 - 8. G1 – channel 1, G2 – channel 2 etc. G9 and G10 are connected to the second A/D Converter, channels 1 and 2.

4 Software Development

This chapter describes the structure of the new developed code. There are two types of codes in this project, Java for the RS-232 communication and the Ladder code for controlling the DMRC Test Rig. Originally the RS-232 communication was supposed to be written in C/C++, but writing and running the RS-232 serial port on a Windows XP based computer was very time consuming and difficult with the experience that was available. The time was running out and therefore a decision was made to write it in Java instead. RS-232 is supported by Java and it is very easy to understand and write the code.

An explanation on how to run the tests for single port relay valve is also explained in this chapter. There was only time enough to add two valves for testing where only one of them is being used. The structure of the code makes it easy to add more valves to the code in the future.

4.1 User Interface

There was not enough time to make a proper user interface so the task still remains. However the rig can still be operated by Java and the captured data can still be saved. To operate the rig the development environment Eclipse is used, the code has also been developed there. Eclipse is a freeware and open source software. The following subsections describe how to run the rig and how to start the tests which have been added.

4.1.1 Starting the test

To run the test Eclipse first needs to be started. While inside Eclipse, locate the Java Class “SerialCom” and run the class, see Figure 16.

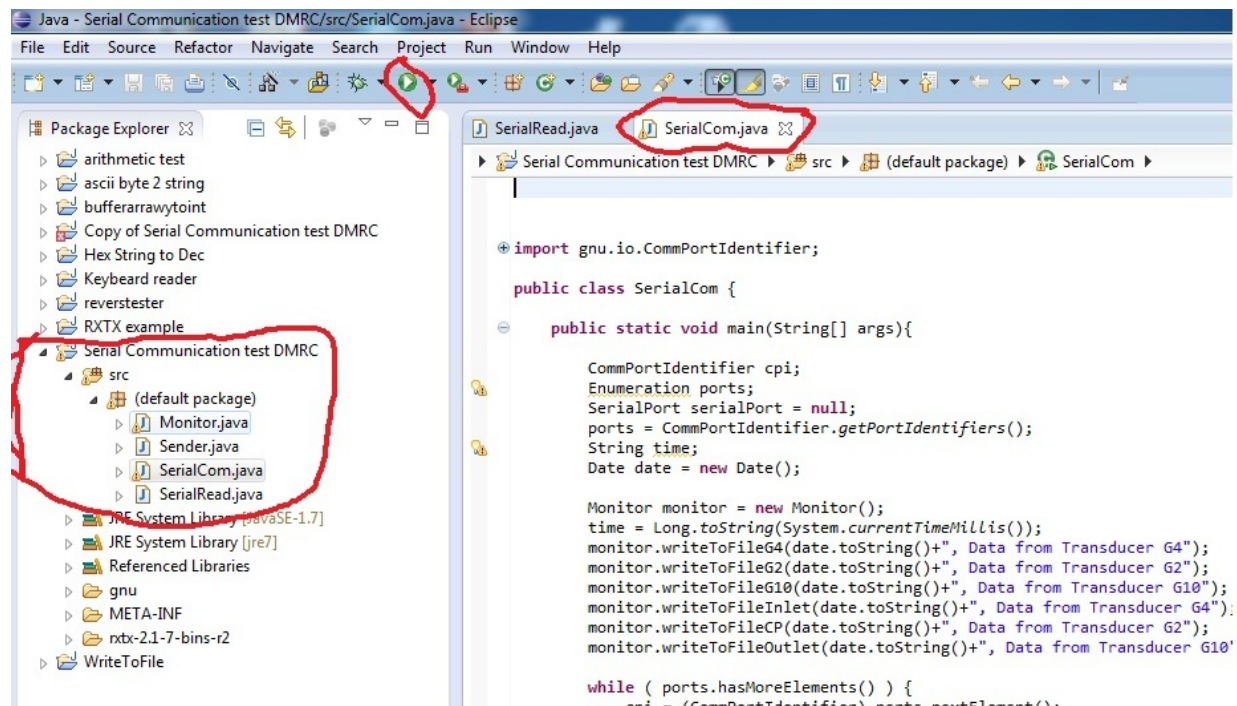

Figure 16. Running SerialCom.

The Java Class “SerialCom” will establish the communication between the PLC system and the Windows XP based computer. To start the test 0 or 1 needs to be typed in the console followed by “Enter” key.

- Sending 0 will trigger the “Warm up” which has to run on every new installed single port relay valve. After the “Warm up” of the valve the endurance and performance test will automatically start running.
- Sending 1 will trigger the endurance and performance test directly.

The captured values will be printed out on the console during the test to make sure the test is running and to ensure there is no problem.

4.1.2 Reading and understanding the text files

The captured data is stored in text files on hard drive “C:\” on the PC. Information about the text files and how they are structured is explained in subsections 4.3.4.2.1 and 4.3.4.2.1. The location where the files are stored can be changed and this is explained in subsection 4.3.4.

“Outlet G10P#” and “ControlPort G2P#” are text files used for processing data, for example the data can directly be copied from the text files to diagrams in Excel for working purposes. “#” in the text file names refers to numbers 1 - 4. These numbers refers to which estimated pressure the data is captured. G10 and G2 refer to which transducer it is in the pneumatic scheme.

Every file has a date stored in the first line. The date tells when the test was started and when the file was created. Whenever someone shuts down the test and restarts it, a new date will be added in the text file. This date will be added in the line after the last stored result. The below text is taken from ControlPort G2P1.

```
0.872  
1.004  
0.924
```

Inlet, *Output* and *ControlPort* are text files which are directly linked to the transducers, in this case G2, G4 and G10. This means that all data the transducers have captured will be stored in these files together with the exact time. These files can be used for locating problems, for example if there are some bad values on “Outlet G10P2”, these values can be matched with values from Outlet to determine at what time it occurred. The text below is taken from the file “ControlPort”.

```
Tue Nov 27 15:37:48 GMT+05:30 2012, Data from Transducer G2  
Tue Nov 27 15:38:32 GMT+05:30 2012, 0.872
```

Files G2, G4 and G10 are the same as Inlet, Output and ControlPort but with dates. Only the date when the file was created is stated.

4.2 RS-232 Communication

The serial communication is used for communication between the PC and the PLC system and to make it possible for one to operate the rig. It is also used for storing results produced by the PLC. RS-232 settings set in the PLC are explained in this chapter and also the structure of the messages.

4.2.1 Settings

The settings shown below are set for the PLC and PC. There is no motivation to why baud rate 9600 was chosen. This setting was default and since there was no information loss during communication this setting was kept. "No parity" and "one stop bit" was also on default and since there were no problem using default values these settings were kept.

- Baud rate 9600
- Non procedural communication
- No parity bit
- One stop bit

No procedural communication is a function for sending and receiving data between a PLC and an external device. An external device is for example a measuring instrument, bar code read, PC etc. The setting is set with GX-Developer. Hand-shaking is not required for this type of communication and was therefore disabled. The receiving and transmission buffer size is by default 600h to 7FFh and 400h to 5FFh which is big enough. The captured data is maximum 24 bits at a time.

4.2.2 Message format

ASCII is an easy way to transmit characters and was therefore chosen as message format. In the current tests only numbers are being used which makes ASCII unnecessary. The decision to use ASCII was made because it is a standard format and to allow future developments.

The following subsections describe how the data is converted in every step from the PLC to PC. The process from when the data is captured with the transducer till how it changes formats, is converted and sent to the PC is described. Also how the PC converts the data after it has been received is explained.

4.2.2.1 PC to PLC

The whole message from the PC to the PLC will be sent as one byte at a time but the message length is undefined and can vary. The message length can easily be changed if it is required in the future. For transmitting from the PC to the PLC, the typing from the keyboard are registered in the Java console and the message will be sent after the enter key has been pressed. The information will be converted into hexadecimal ASCII automatically by Eclipse before it is sent to the PLC. When the PLC has received the message it will just compare the message as hexadecimal ASCII. Depending on the message content different actions will be taken, no conversion in the Ladder code will occur, for example if number 1 is pressed on the keyboard and then the enter key is hit, the PLC will receive the message 31 hexadecimal.

Keyboard [read characters] -> PC [converts to hexadecimal ASCII] -> PLC [reads as hexadecimal value]

4.2.2.2 PLC to PC

The messages used for transmitting from the PLC to the PC will always be 8 bytes. During the transmission only 4 out of 8 bytes will have an assigned value, the rest will be read as null, [0]. The message format used is decimal ASCII because it works for Java to convert it back to characters. Below is a description on what the different bytes in the message are used for. This structure is used in the testing of the Single Port Relay Valve and it can easily be changed if another structure is required.

1. First byte, [0], States at what stage of the process the value has been captured.
2. Second byte, [1], states from which transducer the captured data is from.
3. Third to sixth, [2] – [5], byte is the captured data.
4. The last two bytes, [6] and [7] are empty.

The captured data is first saved in 16 bit format. Before sending the data it will first be converted to decimal ASCII and stored as a byte. When the PC receives the message the first two bytes will be read directly from the buffer as it is. These two bytes are read individually and does not need to be converted. Third to sixth byte, which is the captured data, will be converted into a Java String object.

4.3 Java

The original plan was to program the user interface and the RS-232 communication in C/C++ because this is the main programming language used in the company. Later on it was discovered that it was practically too difficult/time consuming to write the RS-232 communication in C/C++ on a Windows XP system. Instead the decision to write the complete communication code in Java was made. The Java program which is used to establish the connection and communication with the PLC system contains two threads, one monitor and one main class. These classes are described below.

4.3.1 SerialCom

SerialCom is the main class which creates the threads, monitors and also establishes the connection between the PC and the PLC. Starting this class will make it search for an available RS-232 port and establishing the communication. When it has found a port and established the serial communication it will set the communication settings using the line shown below.

```
serialPort.setSerialPortParams(9600, SerialPort.DATABITS_8,  
SerialPort.STOPBITS_1, SerialPort.PARITY_NONE);
```

When the settings have been set it will start two threads, SerialRead and Sender. It will also send an instance to the monitor and a "SerialPort" along with them. Instance to the monitor will allow and help the threads to store data in files. The SerialPort object is needed by the threads for sending and receiving data.

4.3.2 SerialRead Thread

The SerialRead thread is used for receiving data from the PLC. It has a While loop which reads the port periodically. When there is a message incoming the thread will read and store the message.

This thread had a problem during message reception. When the message was sent from the PLC, a fraction of it was read at a time, in the Java code, instead of the complete message, for example if "012345" is sent from the PLC, the PC would receive it like, "01", "234", "5" instead of the complete message "012345". The separation was completely random. Since the data is read fractionally it is impossible to determine from which transducer the beginning and the end data of the message belonged to. Therefore a counter was added, when 6 bytes was read, the buffer was sent to the monitor to process the data. See the code below,

```
final int size = 8;
byte[] buffer = new byte[size];
int total = 0;
int read = -1;
while (total < size && (read = this.in.read(buffer, total, size - total)) >= 0)
{
    total = total + read;
    if(total>=5)
    {
        monitor.putData(buffer, size);
        total = 0;
    }
}
```

Buffer size 8 was needed because the actual message is 8 byte. The last two bytes is not used. It is only there because the buffer should be bigger than the message itself.

4.3.3 Sender Thread

This thread is mainly used for sending data to the PLC. It has a while loop which will register the entered keys and it will transmit to the PLC every time the enter key on the keyboard is hit. Currently it is only used in the beginning of the test to register the entered keys for choosing which test to run. This thread does not need to be more complex since the comparison is done in the PLC. Thread.sleep(100) is needed so the thread does not use all the resources. See code below.

```
while(true){
    try
    {
        int c = 0;
        while ( ( c = System.in.read()) > -1 )
        {
            out.write(c);
        }
    }
    catch ( IOException e )
    {
        e.printStackTrace();
    }
    try {
        Thread.sleep(100);
    } catch (InterruptedException e) {
        // TODO Auto-generated catch block
        e.printStackTrace();
    }
}
```

```

    }
}

```

Sending 0 starts the testing of the Single Port Relay Valve from scratch which means it will start by warming up the valve with a few runs and continue with the endurance and performance test. Sending 1 will start the endurance and performance test immediately.

4.3.4 Monitor

The class Monitor is made for storing captured data into text files on the hard drive. Before storing the files it will first convert the received message into understandable data. To fully understand the contents of the received message, the reader is referred to subsection 4.2.2.

4.3.4.1 `public void putData(byte[] buffer, int size)`

Once the data is received SerialRead Thread will put the data into the monitor using the method “`putData(byte[], int)`”. The transducer and pressure data, telling from which transducer and at what estimated pressure the captured data is taken from, are stored in buffer slots 0 and 1 as integers. These data are received as decimal ASCII and they are not converted into characters.

The captured data, stored in buffer slots 2 to 5, are taken from the buffer as decimal ASCII, converted into characters and stored as a String in the text files. “Date()” is used for updating the time which is stored in the text files as well. This is necessary to see the time when the data was captured.

```

this.buffer = buffer;
this.size = size;
Transducer = buffer[1];
pressure = buffer[0];
s = new String(this.buffer, 2, this.size-2);
n = Double.parseDouble(s);
date = new Date();

```

Once the data is stored and the date is updated the pressure and transducer data will be compared by a switch as integers. Depending on the values they will be processed and stored differently.

When the code has reached the last case the data will be converted into understandable data, bar. But before the conversion, the data varies between 0 – 4000. 0 means 0 bar and 4000 means either 10 or 16 bar depending on which transducer it is. The method “`writeToFile###`” is used to store the data into text files.

As it is shown in the code bellow the second transducer, case 50, does not need an additional switch to determine at which pressure the captured data is taken. This transducer is the main reservoir and should always remain at maximum pressure, 12 bar.

```

switch(Transducer) {
    case 50:
        bar10 = df.format(n/4000*10);
        System.out.println(bar10);
        writeToFileCP(date.toString()+"", "+bar10);
        writeToFileG2(bar10);

```

```

        break;
    case 49:
        bar16 = df.format(n/4000*16);
        System.out.println(bar16);
        writeToFileInlet(date.toString()+" "+bar16);
        writeToFileG4(bar16);
        switch(pressure){
            case 49:
                writeToFileG4P1(bar16);
                break;
            case 50:
                writeToFileG4P2(bar16);
                break;
            case 51:
                writeToFileG4P3(bar16);
                break;
            case 52:
                writeToFileG4P4(bar16);
                break;
        }
        break;

```

4.3.4.2 *private synchronized void writeToFile####(String string)*

This and the following similar methods are used for storing the captured data in text files.

```

BufferedWriter bw = new BufferedWriter(new FileWriter(new File(
    "C:/ControlPort G2P1.txt"), true));

bw.write(string);
bw.newLine();
bw.close();

```

Hard drive "C:/" is the current location where all the text files are stored. The location and the name of the files can easily be changed by changing some lines in the code, note the blue colored text in the code. The pressure values is first added in the text file with the method `bw.write(string)`, then a new line is added with the method `bw.newLine()`. When the data has been written into the text file, the text file is closed so other programs, functions or threads can access it.

"Synchronized" is not necessary yet but it has been added in case future developers decides to add functions, threads or other objects that uses these methods in parallel with the current thread. If the methods are not synchronized and used by more than two threads, the data from the threads can be mixed up during preemption.

4.3.4.2.1 *writeToFileG#P#*

These text files are mainly used for data analysis, for example diagrams in Excel. There are only captured data in these text files, except from the date which tells when the file was created. This date is displayed on the first row. It makes it easy to copy and paste the information to other application without having to separate the dates, which is required using the text files described in subsection 4.3.4.2.2.

5. G# tells which transducer it is. The number # refers to the transducers in the pneumatic schematic.

6. P# is the estimated pressure where the data is captured.

4.3.4.2.2 WriteToFile”...”

“...” refers to the Inlet, Outlet or CP. These text files stores all the data the transducers are capturing. The data is stored together with date and time. These files are used for example to determine the exact time when the captured data was taken. It can then be used for comparing to other text files which are mentioned in the previous subsection, 4.3.4.2.1.

4.3.5 UML

Figure 17 shows a UML diagram of the Java code. It was created using GreenUML.

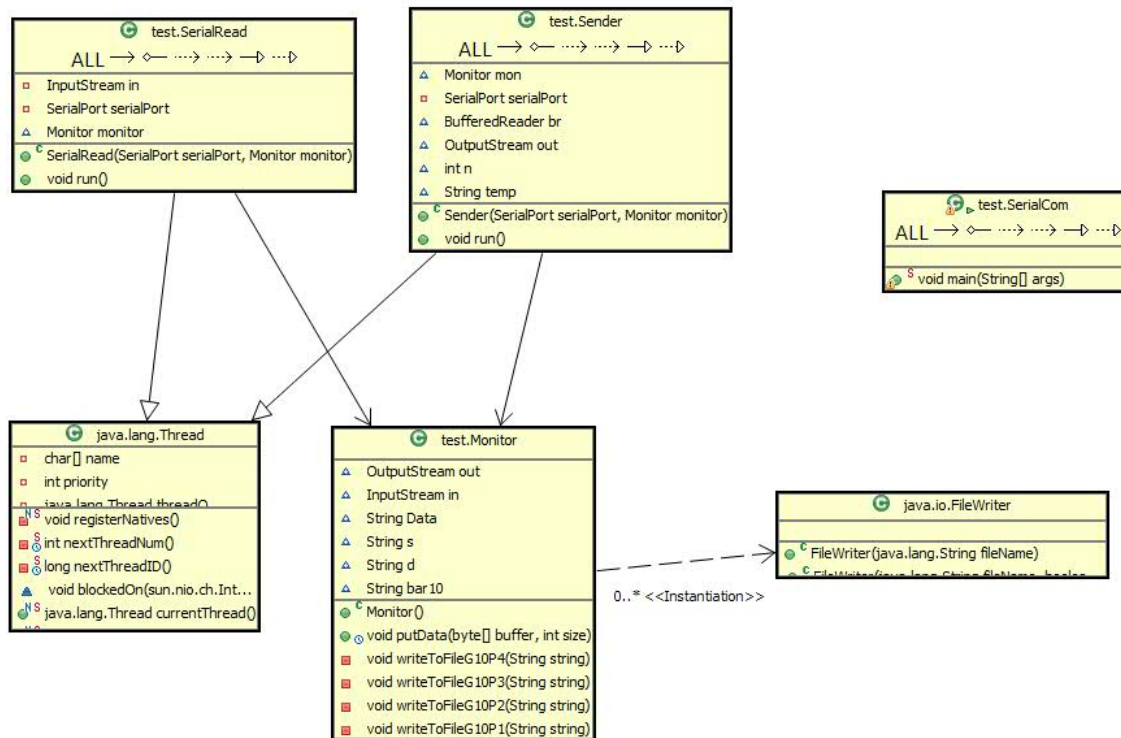

Figure 17. Java UML diagram.

4.4 PLC Ladder

This section describes the structure of the code written for the PLC. The idea behind this subchapter is to make it easy for future developers to understand the structure of the code so they later can further develop/add new valves to the code.

4.4.1 PLC Valve Connections and Structure

To control the pneumatic valves installed in the DMRC Test Rig, it is required to know which port on the output module is connected to which valve. As it says on the electrical schematic, ports on the output module are connected to relays which are connected to a power supply and the valves. In other words the output module is controlling the valves by relays. Table 1 and Table 2 shows how everything is

connected. Pneumatic valves in Table 1 are used for controlling the air to and from reservoirs. Valves in Table 2 are used for exhausting the air out of the system.

Values which are inside quotation marks in column “Output port on module” means that they have not been double checked and they have not yet been associated to relays in the Ladder code. Some examples are “Y##”, “Y42”, “Y43” etc. Values inside quotation marks in column “Associated Relay for Controlling” mean they can be associated to the mentioned relays to follow the logical order. Some example are “M###-M###”, “M1300-M1399”, “M1400-M1499” etc. For more information about port names and module see to datasheet (7). The programming can be found in the code starting at row 110.

Table 1. 2/2 valves / cocks.

Valve on Pneumatic scheme	Output Port on Module	Associated Relay for Controlling	Type of Valve
C1	Y40	M1200-M1299	Old 2/2 Valve / Cock
C2	Y41	M1100-M1199	Old 2/2 Valve / Cock
C3	“Y42”	“M1300-M1399”	Unknown
C4	“Y43”	“M1400-M1499”	Unknown
C5	Y44	M1500-M1599	New 2/2 Angle Valve
C6	“Y45”	“M1600-M1699”	New 2/2 Angle Valve
C7	“Y46”	“M1700-M1799”	New 2/2 Angle Valve
C8	“Y47”	“M1800-M1899”	New 2/2 Angle Valve
C9	“Y48”	“M1900-M1999”	Unknown

Table 2. Exhaust valves.

Valve on Pneumatic scheme	Output port on module	Associated relay for controlling	Type of Valve
D1	Y49	M2200-M2299	Old 2/2 Valve / Cock
D2	Y4A	M2100-M2199	Old 2/2 Valve / Cock
D3	“Y4B”	“M2300-M2399”	Old 2/2 Valve / Cock
D4	“Y4C”	“M2400-M4399”	Old 2/2 Valve / Cock
D5	“Y4D”	“M2500-M2599”	Old 2/2 Valve / Cock
D6	Y4E	M2600-M2699	Old 2/2 Valve / Cock
D7	“Y4F”	“M2700-M2799”	Old 2/2 Valve / Cock

4.4.2 A/D Converters and Pressure Transducers

Pressure transducers are directly connected to channels on the A/D module. There are 5 A/D modules connected but only 2 are being used for the pressure transducers. All transducers are the same except for those which are connected to line 1/inlet line; They are the transducers G3 and G4 on the pneumatic schematic presented in Appendix A. The pressure range for those transducers is 0-16 bar instead of 0-10.

4.4.2.1 Settings and Switch Settings on the A/D Module

Average amount of time processing has been chosen for reading the analog signals. This was chosen because it is easier to control and set time limits on the measuring time. There are also no advantages choosing number of processing repetitions. Sampling time is set to 1000 ms on every channel connected to the transducers except for G3. The sampling time on G3 is set to 10 ms because 1000 ms was too slow for testing the single port relay valve on decreasing pressure. Too much pressure was released during 1000 ms. These settings can be found in the Ladder code starting at row 0.

Switch settings are set to 4 – 20 mA as analog input range which is also the transducers output range. Normal resolution mode is chosen which will make the converted signal range between 0 – 4000 in the Ladder code. 4000 will be 10 bar for all the transducers except from G3 and G4 referred in the pneumatic schematic, where it will be 16 bar and 0 will be equal to 0 bar. The reason why 4000 is used and not 4095 is explained in section 3.1.1. For more information about the module and how to program it is given in (3).

Table 3 is table showing which channel on the module each transducer is connected to and also which slot on the base rack the module is connected to.

Table 3. Transducer connections.

Transducer on Pneumatic Scheme	Channel on module	Slot on Base rack (0-11)
G1	1	3
G2	2	3
G3	3 (10 ms sampling time)	3
G4	4	3
G5	5	3
G6	6	3
G7	7	3
G8	8	3
G9	1	4
G10	2	4

4.4.3 D/A Converter and Pressure Regulators

The D/A converter which is installed in slot 8 (0-11 slots) is used for controlling the pressure regulators. Switch settings are set to 4 – 20 mA and normal resolution mode, 0-4000. The reason why 4000 is used and not all 4095 is explained in section 3.1.2. By setting certain values on the module, between 0-4000, it will give an output between 4 – 20 mA. Depending on the analog outputs the pressure regulators will set a pressure, 0-10 bar. For more information and how to program the module see (4).

4.4.4 PCALL and CALL

Call functions have been used for operating valves easily and to easily access functions which are used frequently. These functions are for example basic operations such as draining the lines, closing the lines, reading the pressure transducers etc. The functions can be found in the Ladder code starting at row 852.

Below are two tables showing CALL functions and its operations. Table 4 provides functions related to the valves. Table 5 presents functions related to processing captured values and transmission of data. D338 – D349 are constant values which are being used in the test of the single port relay valve. These fixed values are used for referring to which transducer and at what pressure/stage the data is captured. These values can also be used in other tests to refer to which stage of the test the values are captured in. The values can be seen in the code starting at row 145.

Table 4. CALL functions, valves.

CALL Functions	Operation	“O” = Open, “C” = Close
P10	Drain all lines	O: C1, C2, C5, D1, D2, D6
P11	Stop drain all lines	C: C1, C2, C5, D1, D2, D6
P12	Open line 1	O: C1, D1
P13	Close line 1	C: C1, D1
P14	Open line 2 and 4	O: C1, C5
P15	Close line 2 and 4	C: C1, C5
P16	Open line 1, 2 and 4	O: C1, C2, C5
P17	Close line 1, 2 and 4	C: C1, C2, C5
P18	Drain line 1	O: D1
P19	Stop drain line 1	C: D1

Table 5. CALL functions, saving and converting.

CALL Functions	Operation	Which slots, “>” = Saves to
P100	Save transducer values	G2 > D302, G4 > D304, G10 > D310
P101	Save transducer values	G2 > D374, G3 > D373, G4 > D372, G10 > D380
P103	Convert data to Dec ASCII	D302 > D361-D364, D338 > D360
P104	Convert data to Dec ASCII	D304 > D361-D364, D339 > D360
P105	Convert data to Dec ASCII	D310 > D361-D364, D340 > D360
P106	Convert data to Dec ASCII	D302 > D361-D364, D341 > D360
P107	Convert data to Dec ASCII	D304 > D361-D364, D342 > D360
P108	Convert data to Dec ASCII	D310 > D361-D364, D343 > D360
P109	Convert data to Dec ASCII	D302 > D361-D364, D344 > D360
P110	Convert data to Dec ASCII	D304 > D361-D364, D345 > D360
P111	Convert data to Dec ASCII	D310 > D361-D364, D346 > D360
P112	Convert data to Dec ASCII	D302 > D361-D364, D347 > D360
P113	Convert data to Dec ASCII	D304 > D361-D364, D348 > D360
P114	Convert data to Dec ASCII	D310 > D361-D364, D349 > D360

4.4.5 RS-232 Communication

All the communication methods, settings and how to program the module are described in (9) and (8). The basic settings and the structure of the transmission/reception are explained in this section.

4.4.5.1 Switch/Transmission/Receiving Settings

Switch settings are set to 05C2/0006/0000/0000/0000. These settings will result in the following transmission settings shown below.

- 8 data bits
- None parity bit
- 1 stop bit
- Communication rate 9600 bps
- Communication protocol setting to Non Procedural Protocols

Choosing “Non Procedural Protocol” leads to G.OUTPUT and G.INPUT commands will be used for transmission and reception in the Ladder code. The transmission settings are set in D350 to D352 which states that channel 1 will be used and data count set to 4 words, 8 bytes. The reception settings are set in D700 to D702 which states that channel 1 will be used and the allowable number of words for received data to be stored is 1, the rest are default. Transmission and reception message settings can be found in the code starting at row 180. More information about these commands can be found in datasheet (8).

4.4.5.2 Sending Messages

The messages which will be sent from the PLC are the captured values from transducers. The standard endurance test is 1 million cycles, for example in the single port relay valve test, to store values from three different transducers for 1 million cycles at 7 different stages will lead to 21 million values. The PLC does not have enough memory slots to store 21 million values. Using serial communication to store the data on the local hard drive on a desktop PC is a way of solving the problem.

The way the captured data is processed and sent using Ladder codes are described below in steps 1-3.

1. The data is stored temporarily in PLC memory slots using the written CALL Function “CALL P100”. When the CALL Function is finished, a relay will be activated so the next step can start, see Figure 18.

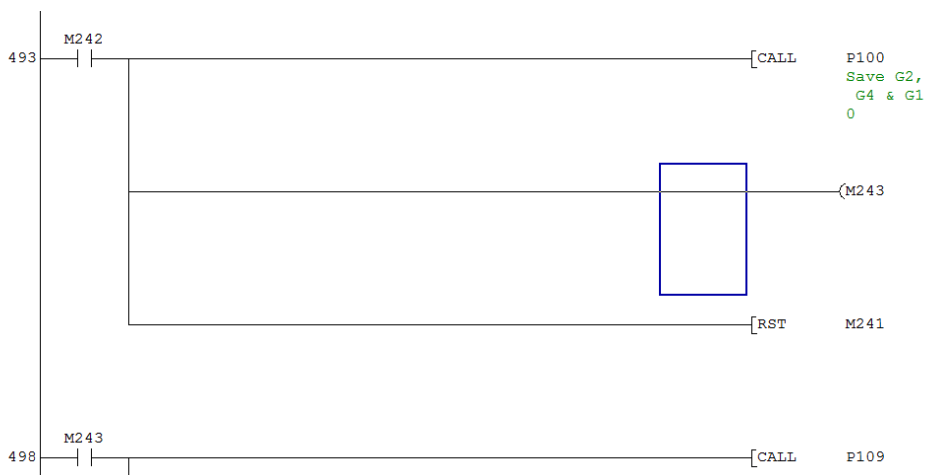

Figure 18. Ladder CALL P100.

- Now a two digit fixed value and the captured data are converted into decimal ASCII using CALL functions P103 – P114. The fixed value is stored in the PLC memory slot D360 and is needed later in the Java code to determine at which stage the transducer captured the data. Choosing CALL functions P103 – P114 also determines from which transducer the data is converted and stored. The conversion will turn the 16 bit value into decimal ASCII and store it in D361-D365. Though only D231-D364 will be used.
- When the data has been converted and stored in a certain order, D360 – D365, the message can be sent using the command G.OUTPUT. Figure 17 shows an example of the transmission after the CALL function P110 has been used.

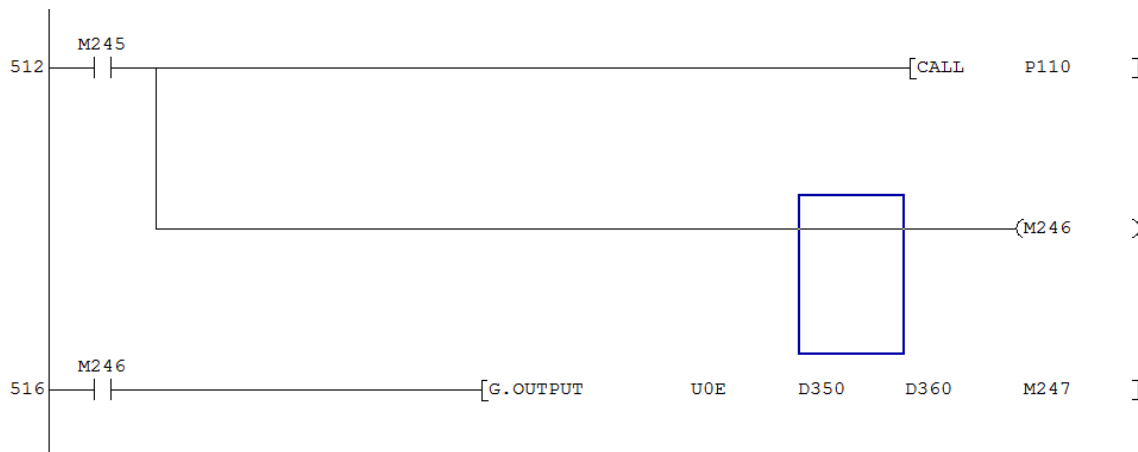

Figure 19. Ladder code, transmission.

4.4.5.3 Receiving Messages

Receiving messages are easier than them. When the module receives a message from the PC the relay X0E3 (X3) becomes active and the command G.INPUT will start executing. The module will receive the complete message and store it in D800. When the message is received and stored the comparison will start. Depending on the value, different relays (M306 or M307) becomes active. When the relay has turned active the code will start running automatically. The start of the code which triggers M306 or M307 will only trigger on rising edge so the tests cannot be disturbed by more messages or spam during its run. Figure 20 shows the reception procedure and the comparison of the received value which is stored in D800.

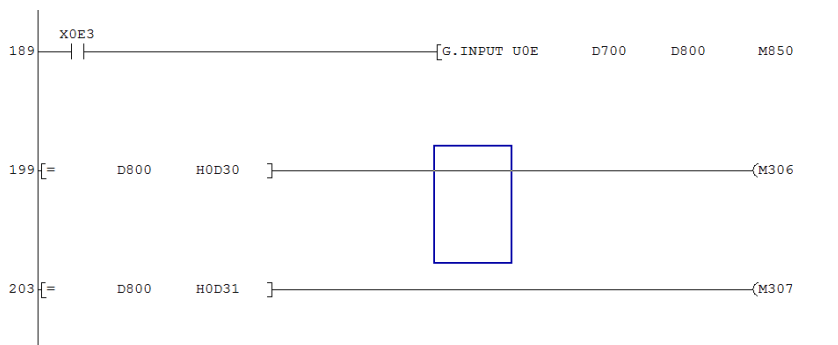

Figure 20. Ladder Code, Reception.

5 Current Testing Methods

This chapter gives a brief description on how the main three tests currently are being done, which are the Endurance test, Performance test and Leak test. The purpose of this chapter is to give the reader a deeper understanding on how the testing currently is being done so it later can be compared to the new testing method with the DMRC Test Rig.

5.1 Endurance Test

The endurance test is very simple, the test rig is manually built, customized for each of the valves and is more of an arrangement than a fixed physical rig. It can test several valves at the same time if they are of the same type. Basically it consists of timers, electric 2/2 valves, tubes and air supply. The pressure in the system is manually set, the 2/2 valves are triggered by the timers which will control the direction of the air flow. This will then simulate the valve in operation.

The valves are all connected in parallel to each other to make it possible to test several valves at the same time. There is nothing to stop the air between each of the valves which means if a valve fails and for example starts leaking air through a port, it will then affect the rest of the valves and therefor the final result. No data will be saved during the test. It is only possible to read data through the analog gauge which means there is no guarantee that the valves have functioned during the whole time nor delivered the right results. When a valve change occurs, a customization needs to be done to the arrangement. A new setup has to be made where tubes, timers, valves have to be manually rearranged or changed and reset.

5.1.1 Endurance Test on Double Port Relay Valve

An explanation is given on how the current endurance test is being done on the double port relay valve. This section is to give the reader a deeper knowledge in the endurance testing methods. Information on how the double port relay valve functions and how it is tested, see subsection 6.1.3.2.

The setup contains air supply, analog gauges, pressure controller, timer, solenoid and a reservoir. The testing valves are connected in parallel to each other. Figure 21, taken from (11), is a schematic showing the test rig setup. The timer will be giving pulses at a frequency. It will then shift the solenoid (NC) to either set pressure (5 bar) to the control ports (CP) or release the pressure. If the control port receives the pressure 5 bar the valve will let the air from main reservoir (7 bar) to flow through the valve and into a 1L reservoir. The analog pressure gauge on the 1L reservoir can be read during the whole test. When the timer triggers again, so the control air (5 bar) is let out to the atmosphere, the control port will sense 0 bar. The valve will then exhaust its inner pressure and the air inside the 1L tank will reduce to 0 bar.

2 CONTROL PORT RELAY VALVES ENDURANCE TEST SCHEME
 OPERATING FREQUENCY 30 CYCLES/MINUTE

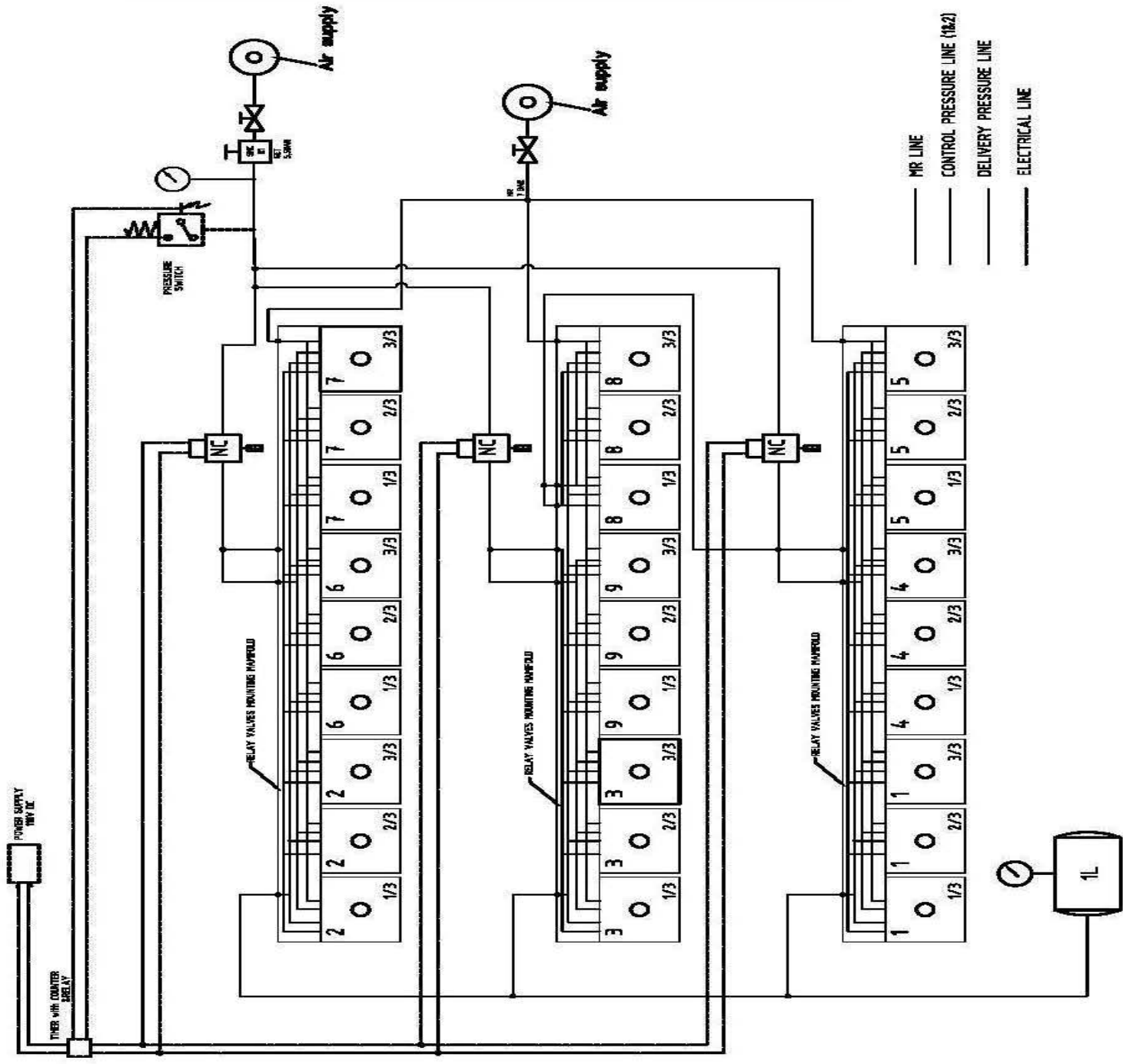

Relay Valve DOE Endurance Test for Lock Nut Loosening
 018 0070 00

Place : Erige Lab. Date : May'03 '11

SI No.	Method of Tightening	Cleaning Grease before Loctite Used	Presence of Oil	Loctite Used	No. of Valves	When the Nut gets loosened
1	W/O FIXTURE	No	No	No	3	
2	W/O FIXTURE	No	Yes	No	3	
3	W/O FIXTURE	No	Yes	Yes	3	
4	Fixture + 30 Nm	No	No	No	3	
5	Fixture + 30 Nm	No	No	Yes	3	
6	Fixture + 30 Nm	No	Yes	No	3	
7	Fixture + 30 Nm	No	Yes	Yes	3	
8	Fixture + 30 Nm	Yes	No	Yes	3	
9	Fixture + 30 Nm	Yes	Yes	Yes	3	

Figure 21. Double Port Relay Valve Endurance Test Schematic.

5.2 Performance & Leak Test

Every valve has to run a performance test and some have to run leak tests as well before they are approved for delivery. The reason for running a performance test is for example to check whether the valve is delivering the right pressure or the right volume of air. This is very important for certain valves. Leak tests can be done in several ways. Some need to be sunk down into a water solution to check for bubbles and for some it is enough just to listen to the sound of air coming out.

There are several fixed rigs for performance and leak testing. Everything is manually set and controlled. For most of the valves the data are read visually on analog pressure gages and noted down by pen and paper. Some valves are measured digitally with better accuracy but they are also noted down with pen and paper. Performance and leak testing the valves can take up to 2 hours and sometimes even more depending on which valve it is.

6 Pneumatic Brake Valves for Testing

There are many types of pneumatic valves but the valves focused in this project are primary used for the train brake systems. These valves are more detailed explained in this chapter to give the reader a deeper understanding about the valves.

6.1 Brake Valves

Functions, test specifications and requirements for each valve that needs to be tested are described in this chapter. Also a description on how the valves possibly can be tested in the DMRC Test Rig is given. Each of the valves has been studied closely to find different ways of testing the valve in the DMRC Test Rig without doing any modifications to it. The information about the valves has been taken from specific documents and drawings. The documents describe the functionality of the valves and also how they should be tested.

The following definitions are made to ease the description of each valve.

- *Inlet* means the port where the air from the main reservoir enters
- *Outlet* is the port where the air normally exits
- *Control Port (CP)* is the port where the control air will enter/affect for example controlling the outlet
- *Exhaust* is the port where the air exits

6.1.1 Pressure Regulator (Limiting Valve)

This valve regulates the pressure on the outlet port with the condition that the inlet always has to have a higher pressure. The valve also has an exhaust port in case the pressure gets too high on the outlet port, the air will then exhaust to ease the pressure. Figure 22 shows the pneumatic symbol of the pressure regulator.

This valve has three ports:

- Inlet
- Outlet
- Exhaust

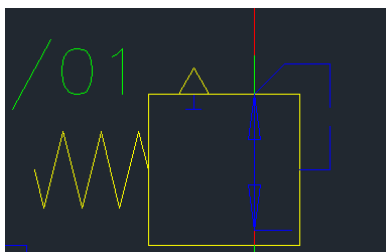

Figure 22. Symbol for pressure regulator.

6.1.1.1 Test Specifications and Requirements

Test requirements:

1. Inlet 7 bar should give outlet 5 ± 0.05 bar
2. Inlet 7 bar. Open outlet port so a pressure drop occurs then close again. Outlet pressure should return back to 5 ± 0.05 bar.
3. Let 7 bar through a 0.3 mm choke enter out. Out should not change more than 0.3 bar. Also check the reverse.

Due to the choke, a bigger modification to the DMRC Test Rig is required if an identical performance test is to be made. The highest tolerance on this valve is 2% of the pressure. Together with the pressure from the transducers it can have a final variance of 0.00050505 bar which is too low. The calculations can be seen in Appendix D.

For more information on how to test the valve, see (12).

6.1.2 Variable Pressure Regulator

This valve is the same as the pressure regulator except for that this valve has an extra control port. Depending on the pressure applied to the control port it will set the pressure in the outlet, under the condition where the Inlet has to have a higher pressure than the outlet. The pressure in the outlet should remain constant even if the pressure in the inlet varies. Figure 23 shows the pneumatic symbol of the variable pressure regulator.

This valve has three ports:

- Inlet
- Control Port
- Outlet

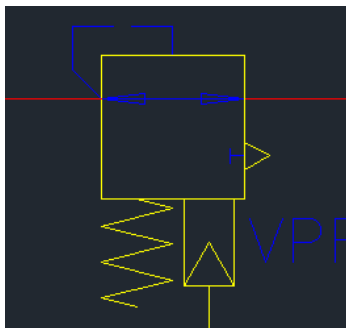

Figure 23. Symbol for variable pressure regulator.

6.1.2.1 Test Specifications and Requirements

Testing this valve is similar to the pressure regulator except for the control port. For the exact test routine, see (13).

6.1.2.2 How to Test with the DMRC Test Rig

A possible way of testing this valve on the DMRC Test Rig is explained below. The highest tolerance required on this valve is calculated below and the current transducers are accurate enough to measure the values.

$$\frac{0.2}{5.2} = 3.84\%$$

Figure 24 shows an installation which makes it possible to test the valve on the DMRC Test Rig without any modifications.

Tests possible to perform:

- Performance
- Endurance

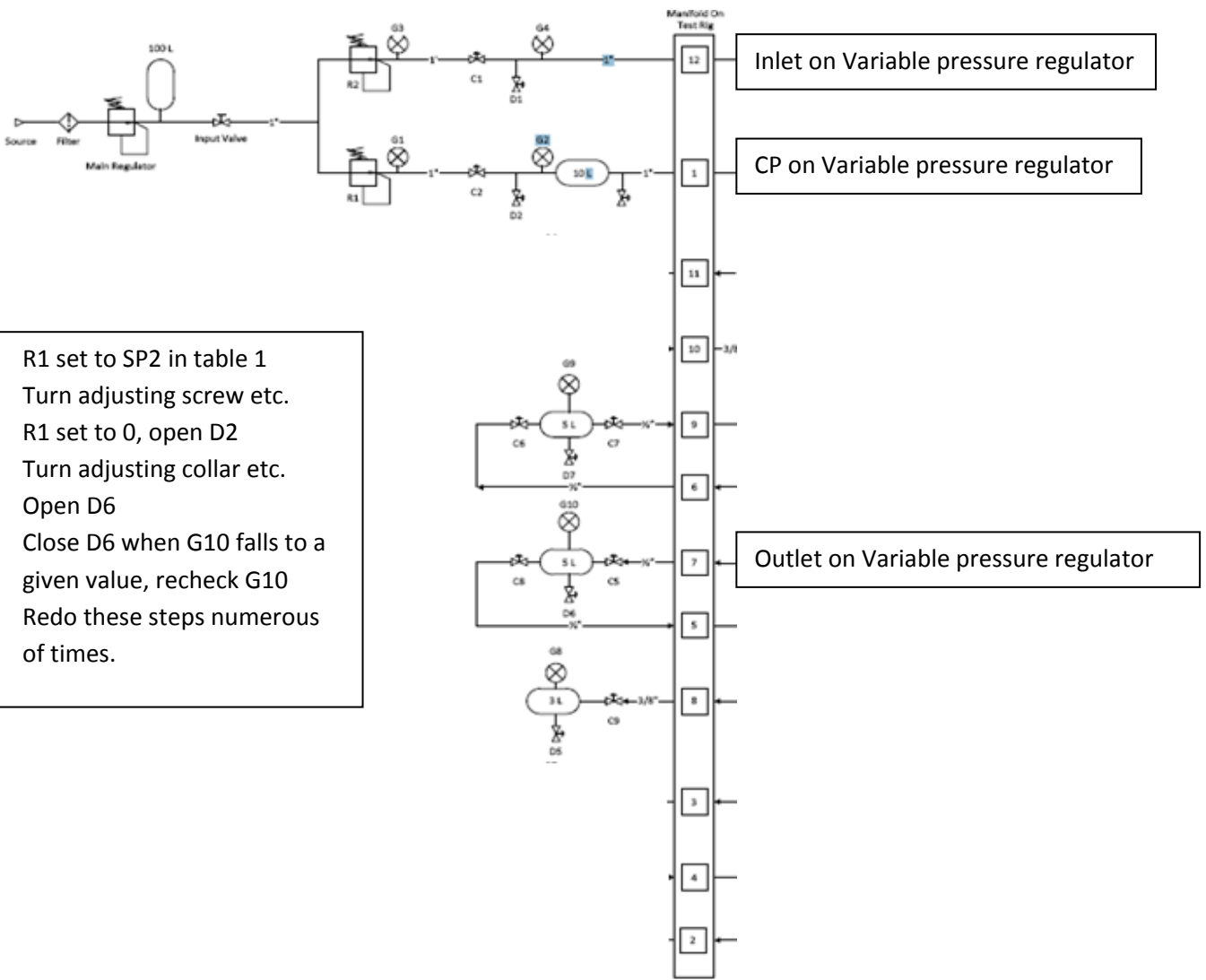

Figure 24. Variable pressure regulator on the DMRC Test Rig.

6.1.3 Relay Valves

These valves are pressure-controlled pressure regulators. Depending on the pressure applied to the control port it will determine the pressure in the outlet. The pressure in the outlet is proportional to the pressure in the control port by 1/1. If the pressure in the outlet is too high the relay valve will exhaust the air until the right pressure is achieved.

6.1.3.1 Single Port Relay Valve

This valve has four ports:

- Inlet
- Outlet
- Control port
- Exhaust

Figure 25 shows the pneumatic symbol of the single port relay valve.

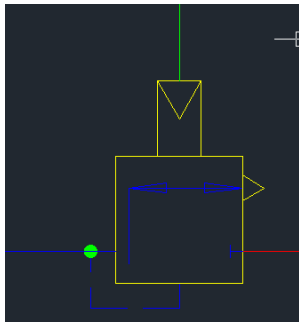

Figure 25. Symbol for single port relay valve.

6.1.3.1.1 Test Specifications and Requirements

The way the single port relay valve is designed has given the valve different tolerances depending on if the pressure in the control port was increasing or decreasing. Table 6 shows the tolerances on the pressure in the outlet, when the pressure is increasing in the control port, for example if the pressure in the control port increased from 1 to 2 bar, the pressure in the outlet should not vary more than $2^{+0.05}_{-0.15}$ bar. Table 7 shows the tolerances on the pressure in the outlet, when the pressure in the control port is decreasing, for example if the pressure in control port was decreasing from 2 to 1 bar, the pressure in the outlet should not vary more than 1 ± 0.1 bar

Table 6. Tolerances for raising the pressure on control port.

Test requirements for Single Port Relay Valve		
MR (bar)	CP (bar)	Out (bar)
10	1	$1^{+0.05}_{-0.15}$
10	2	$2^{+0.05}_{-0.15}$
10	3	$3^{+0.05}_{-0.15}$
10	3.5	$3.5^{+0.05}_{-0.15}$

The maximum tolerance, when the pressure is rising in the control port, is $3.5^{+0.05}_{-0.15}$ bar. If the accuracy of the transducer is included in the calculation, the tolerances can vary between 3.3874 - 3.5649 bar when the expected pressure is 3.5 bar. This leads to a maximum tolerance of +0.0149 and -0.1126 bar, calculations can be found in Appendix D.

Table 7. Tolerances for decreasing the Pressure on control port.

Test requirements for Single Port Relay Valve		
Inlet (bar)	CP (bar)	Out (bar)
10	3	3 ± 0.1
10	2	2 ± 0.1
10	1	1 ± 0.1
10	0	0

The maximum tolerance, when the pressure is decreasing in the control port, is 3 ± 0.1 bar. If the transducer accuracy is included, the measured value can vary a maximum of +0.0693 and -0.0707 bar, calculations can be found in Appendix D. The transducers installed in the DMRC Test Rig should be accurate enough to measure the ports on this valve.

For more information on how to test this valve, see (14).

6.1.3.1.2 How to Test with DMRC Test Rig

Figure 26 is a brief description on how the test possibly can be done with the DMRC Test Rig without any major modifications.

Tests planned to perform:

- Performance
- Endurance

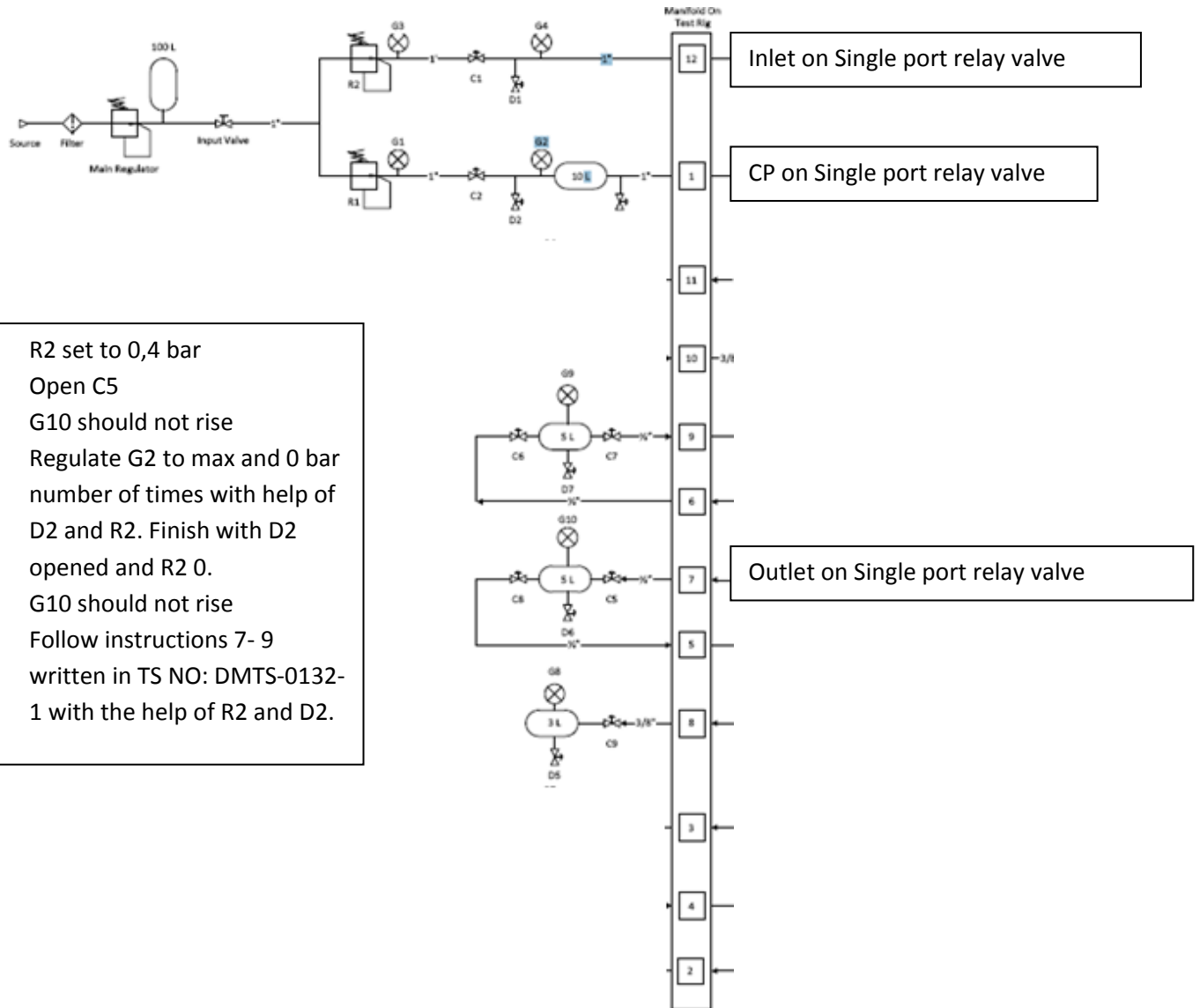

Figure 26. Structure to test single port relay valve with existing rig.

6.1.3.2 Double Port Relay Valve

This valve is the same as the single port relay valve except for that this valve has two control ports. The control port with highest pressure determines the pressure in the outlet.

This valve has 5 ports:

- Inlet
- Outlet
- Exhaust
- Control port 1 & 2

Figure 27 shows the pneumatic symbol for the double port relay valve.

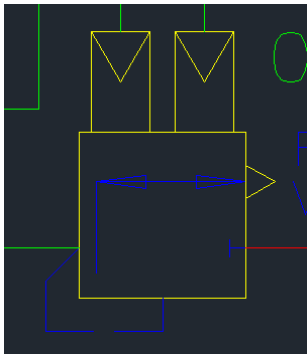

Figure 27. Symbol for double port relay valve.

6.1.3.2.1 Test specifications and requirements

The way the double port relay valve is tested is similar to how the single port relay valve is tested and therefore it will not be described any further. For the exact test specifications, see (15).

6.1.3.2.2 How to test with the DMRC Test Rig

There is a possibility to do the test on the DMRC Test Rig without any major modifications. Figure 28 is a brief description on how the valve should be installation in the DMRC Test Rig to make it possible to test the valve.

Tests planned to perform:

- Performance
- Endurance

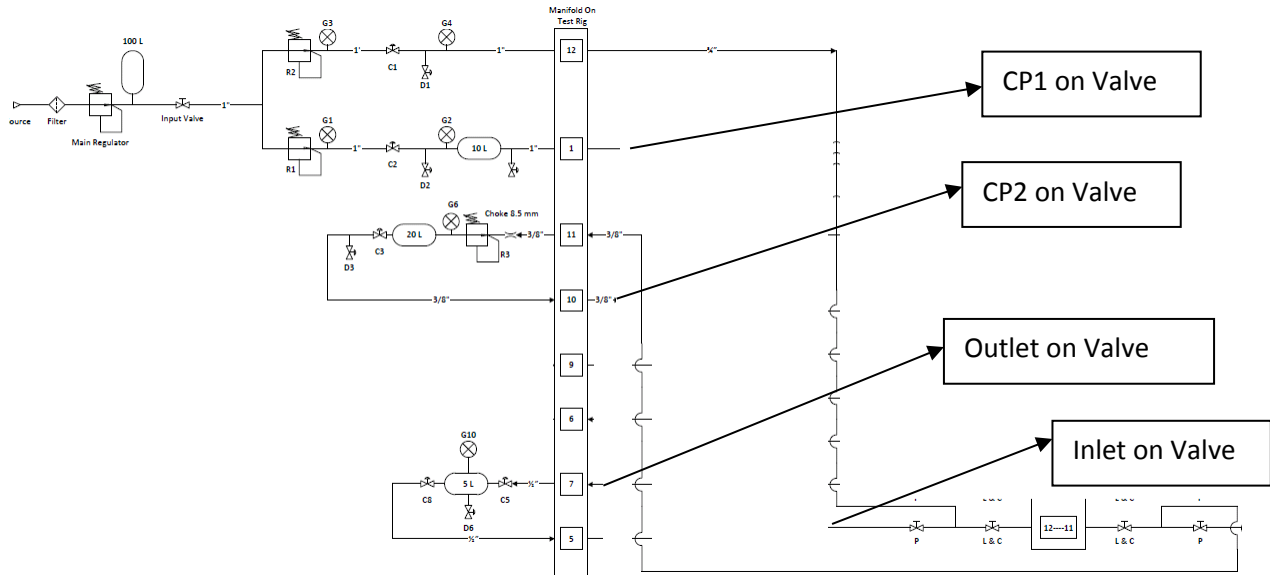

Figure 28. Structure to test double port relay valve on existing rig.

6.1.4 Single Hose Protection

If the tube connected to the outlet port bursts and the air flows right out to the environment, the design of this valve will automatically shut the port. This valve has one outlet and it will close it if the air gets out too fast. The outflow volume is vital when testing this valve. The right volume of air has to be controlled.

This valve has two ports:

- Inlet
- Outlet

Figure 29 shows the pneumatic symbol of the single hose protection valve.

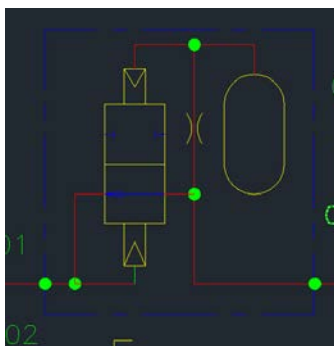

Figure 29. Symbol for single hose protection valve.

6.1.4.1 Test Specifications & Requirements

Performance testing this valve is all about measuring the air flow. Chokes has to be installed to be able to do an identical performance test as it is being done today. For the exact test routine, see (16).

It might be possible to change the current way of doing the performance test to allow performance testing the valve with the DMRC Test Rig. However this will require a lot of work and therefore the conclusion will be that it is not possible to test the performance of this valve.

Endurance test might be possible since it is not required to measure the exact flow. Figure 31 shows how the single hose protection valve can be installed in the DMRC Test Rig to allow it to endurance test the valve.

6.1.5 Double Hose Protection

If a tube connected to one of the outlets on this valve breaks, the valve will automatically close that outlet port, for example if the tube connected to one of the outlet ports bursts and the air flows right out to the environment the design of the valve will automatically close that port. All ports have the port size $\frac{1}{2}$ ". The difference in pressure between both of the outlet ports is the key function to close one of the ports. This valve is very similar to single hose protection valve, the difference lies in the extra outlet port which the double hose protection valve has.

This valve has three ports:

- Inlet
- Outlet 1 & 2

Figure 30 shows the pneumatic symbol of the double hose protection valve.



Figure 30. Symbol for double hose protection valve.

6.1.5.1 Test Specifications and Requirements

Testing this valve is similar to testing single hose protection valve. As for single hose protection valve, chokes are required to be able to do an identical performance test on this valve. To make it possible to do a performance test with the DMRC Test Rig without any changes, the way of doing and measuring the performance test has to be changed. Changing the way of doing the test requires a lot of work and the conclusion will therefore be it is not possible to do the performance test. For the exact test routine, see (17).

6.1.5.2 How to Test with the DMRC Test Rig

Tests are not possible to perform on this valve with the DMRC Test Rig because chokes are vital for doing the performance and endurance test, the tubes sizes have to be precise. To be able to do the endurance test on this valve, the following change has to be made.

- A choke has to be added to one of the inlet lines of the DMRC Test Rig, either line 1 or 2.

There is still a possibility to do an endurance test by changing the size of the connections/ports. But however this has to be studied closer and might be a project on itself. Figure 31 shows an installation on the DMRC Test Rig that might work if the ports are changed to the right sizes.

To be able to do the performance test with the DMRC Test Rig three chokes have to be added:

- 5.5 mm to either line 1 or 2
- 7 mm chokes to line 3 and 4.

Technically it should be possible to do the performance test by proportionally increasing the size of the inlet port. Then only one choke is needed on line 1 or 2. The outlet will have ½" size and the inlet will have a bigger choke which has been proportionally increased with the outlet port size.

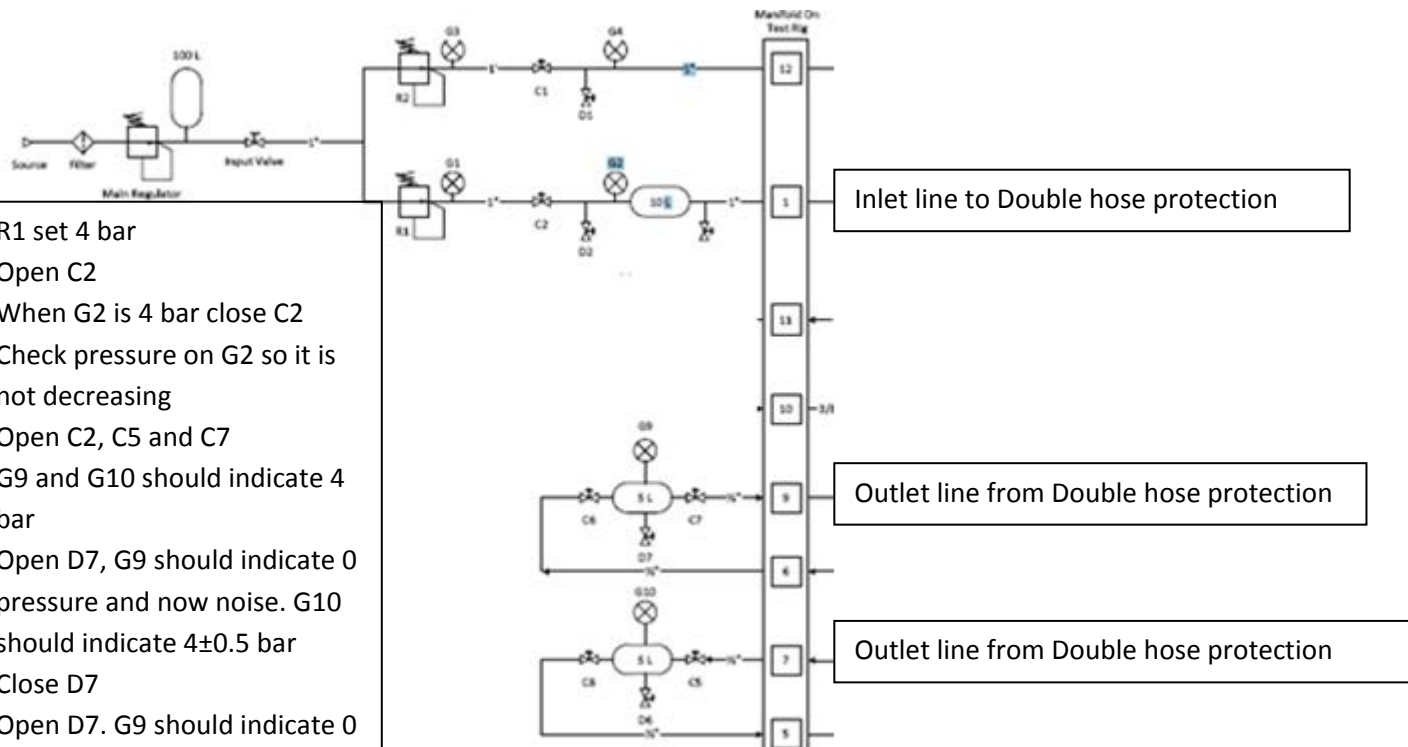

Figure 31. Structure to endurance test double hose protection valve.

- R1 set 4 bar
- Open C2
- When G2 is 4 bar close C2
- Check pressure on G2 so it is not decreasing
- Open C2, C5 and C7
- G9 and G10 should indicate 4 bar
- Open D7, G9 should indicate 0 pressure and now noise. G10 should indicate 4±0.5 bar
- Close D7
- Open D7. G9 should indicate 0 pressure and noise. G10 should indicate 4 bar

6.1.6 Leveling Valves

Depending on the load applied on the mechanical arm attached to the valve, it will regulate the pressure on outlet.

This valve has three ports:

- Inlet
- Outlet
- Exhaust

Figure 32 shows the pneumatic symbol of the leveling valve.

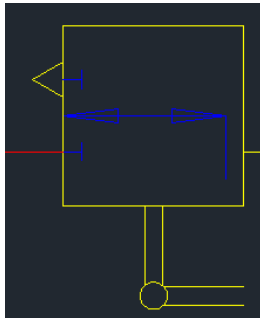

Figure 32. Symbol for leveling valve.

6.1.6.1 Test Specifications and Requirements

This valve is different from the rest because it requires a physical movement to be able to run the valve. In this project the leveling valve will not be focused in due to it might be a project on itself. The test routine involves many steps and will not be explained. The exact test routine for this valve can be seen in (18).

6.1.7 Check Valve

Check valve allows flow in one direction at a certain pressure and stops the flow in the other.

This valve has two ports:

- Inlet
- Outlet

Figure 33 shows the pneumatic symbol of the check valve.



Figure 33. Symbol for check valve.

6.1.7.1 Test Specifications and Requirements

Describing routine test specifications is not necessary. To see the test specifications, see (19).

6.1.7.2 How to Test with the DMRC Test Rig

This valve can be tested with the DMRC Test Rig without any modifications to the rig. Figure 35 presents an installation suggestion that allows the valve to be tested. The installing structure is the same as for duplex check valve.

Tests planned to perform:

- Performance
- Endurance

6.1.8 Duplex Check Valve (Differential Check Valve with a Spring)

Duplex check valve is almost the same as the check valve, except this one allows airflow in the opposite direction. The springs can have various forces which allow different pressures in both directions, for example in one direction the spring allows a pressure at 2 bar and in the other direction it will allow 3 bar.

This valve has two ports:

- Inlet
- Outlet

Figure 34 shows the pneumatic symbol of the duplex check valve.

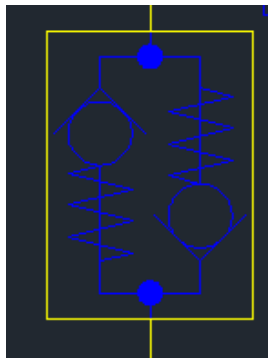

Figure 34. Symbol for duplex check valve.

6.1.8.1 Test Specifications and Requirements

The duplex check valve is assembled with two different settings but they are both tested in the same way. The difference lies in the expected pressure. Testing the volume flow is vital in the performance test of this valve.

Table 8 shows the different pressure data expected in each of the models. This pressure "X" will be used in Table 9, which presents the expected results in each step. For more information on the tests of this valve, see (20).

Table 8. Duplex check valve models.

Part No.	Diff. pressure. 'X' (bar)
039 0016 00	1.0 ±0.2
FT0050908-100	1.5±0.2

Table 9. Expected test results for duplex check valve.

Port A	Port B
3 bar	Should give 3-X bar after approx. 30 sec
8.5 bar	Should give 8.5-X bar after approx. 30 sec
4 bar	4+X bar
0 bar	X bar

6.1.8.2 How to Test with the DMRC Test Rig

With the current testing methods, different sizes of reservoirs are used compared to the ones in the DMRC Test Rig. Using different reservoirs leads to different results but the new expected results can easily be recalculated.

Figure 35 presents how the duplex check valve can be installed in the DMRC Test Rig to allow it to be tested.

Tests planned to perform:

- Performance
- Endurance

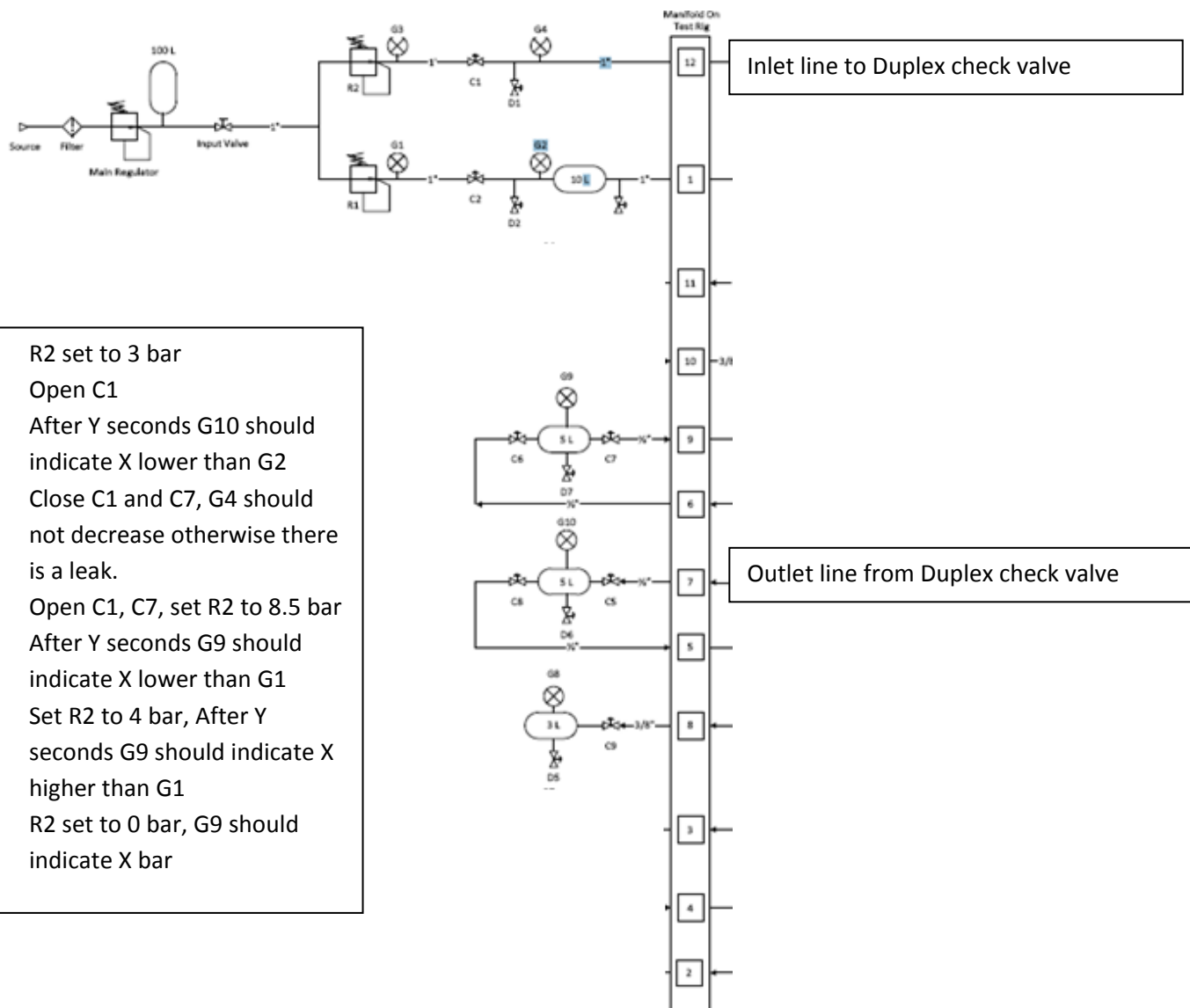

Figure 35. Structure for testing duplex check valve.

6.1.9 Auto Drain Valve

This is basically a 2/2 valve controlled with a spring at one condition and pneumatically at the other. There is a reservoir connected for drainage. When the pressure in the control port is above 5.7 – 6.7 bar the reservoir will be drained on air to the environment.

This valve has three ports:

- Inlet
- Control Port
- Exhaust

6.1.9.1 Test Specifications and Requirements

Table 10 presents the expected values depending on the state. For the exact test routine see (21).

Table 10. Expected results for auto drain valve.

Inlet (bar)	Control Port (bar)
State 1 to 2 (repeat 4-5 times)	
9.5 (0 at state 2)	5.9-6.7
State 2 to 1 (CP on exhaust)	
0 (9.5 after a while at state 2)	1.7 – 2.3

6.1.9.2 How Test with the DMRC Test Rig

Performance and endurance tests are possible to do in the DMRC Test Rig. Figure 36 presents how the valve can be installed in the DMRC Test Rig which allows the valve to be tested.

Tests planned to perform:

- Performance
- Endurance

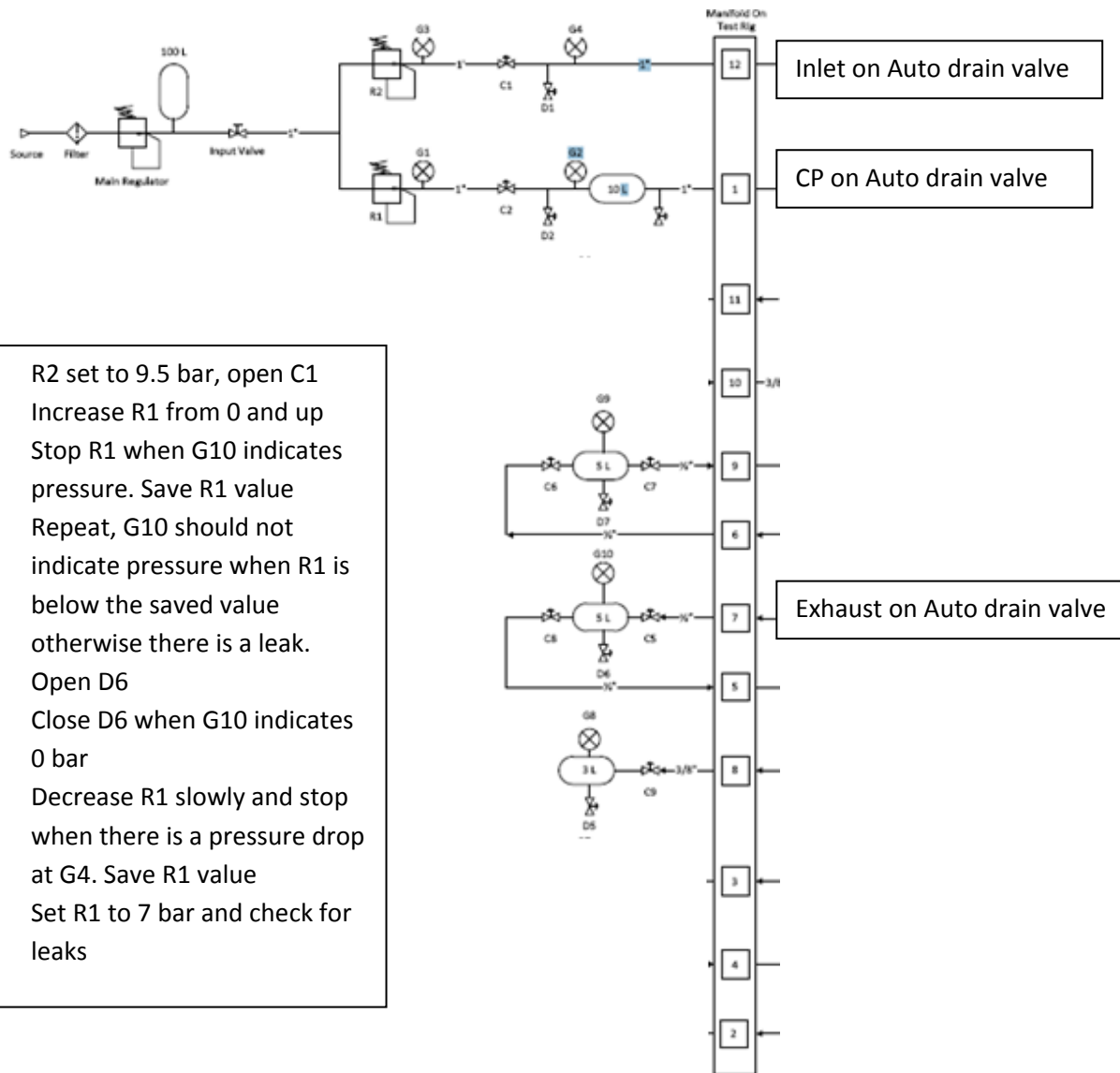

Figure 36. Possibly installation on auto drain valve.

6.1.10 2/2 EP Valve

This valve has two modes, to change mode it needs an electrical signal and a pneumatic pressure. When there is no pressure or an electrical signal, it will return to its original state. The valve is normally closed.

This valve has two ports:

- Inlet
- Outlet

Figure 37 shows the pneumatic symbol of the 2/2 EP valve.



Figure 37. Symbol for 2/2 EP valve.

6.1.10.1 Test Specifications & Requirements

The valve will be tested the same way as the 3/2 EP valve and is therefore not described in this section.

Tests planned to perform:

- Performance
- Endurance

6.1.11 3/2 EP Valve

This 3/2 valve has two modes, to change mode it needs an electric signal and a pneumatic pressure. When either the signal or the pressure is missing the valve will return to its original mode. The valve is normally closed/ releasing air to environment.

This valve has three ports:

- Inlet
- Outlet
- Exhaust

Figure 38 shows the pneumatic symbol of the 2/3 EP valve.

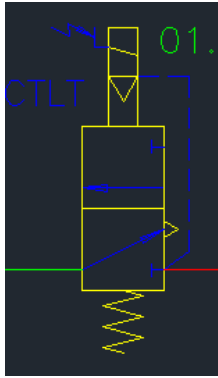

Figure 38. Symbol for 3/2 EP valve.

6.1.11.1 Test Specifications and Requirements

Table 11 shows what values are expected in different states. For more information about routine test specification, see (22).

Table 11. Performance test values on 3/2 EP valve.

State 1		
Inlet	Outlet	Exhaust (3/2 only)
9 bar	0 bar	Exhaust = outlet bar
State 2 (Electrical signal on coil)		
Inlet	Outlet	Exhaust (3/2 only)
X bar	X bar	0 bar
9 bar	0-8 bar in 1,5±1 sec	0 bar
State 2 (too high pressure)		
Inlet	Outlet	Exhaust (3/2 only)
Too high, S bar	Above 0 bar	Exhaust = Outlet bar

This test has to be tried with 70% of rated voltage and spring force vs. pressure.

6.1.11.2 How to Test with the DMRC Test Rig

An external power supply needs to be installed in the DMRC Test Rig to be able to run any test on this valve. The time mentioned in the routine test specification has to be recalculated due to the difference reservoir volume. The current volume of the reservoir used in performance test is 6 liters. The available reservoirs in the DMRC Test Rig are 3, 5 or 10 liters. Depending on which reservoir to use different time will be expected.

Figure 39 presents an installation in the DMRC Test Rig which allows the valve to be tested.

Tests planned to perform:

- Performance
- Endurance

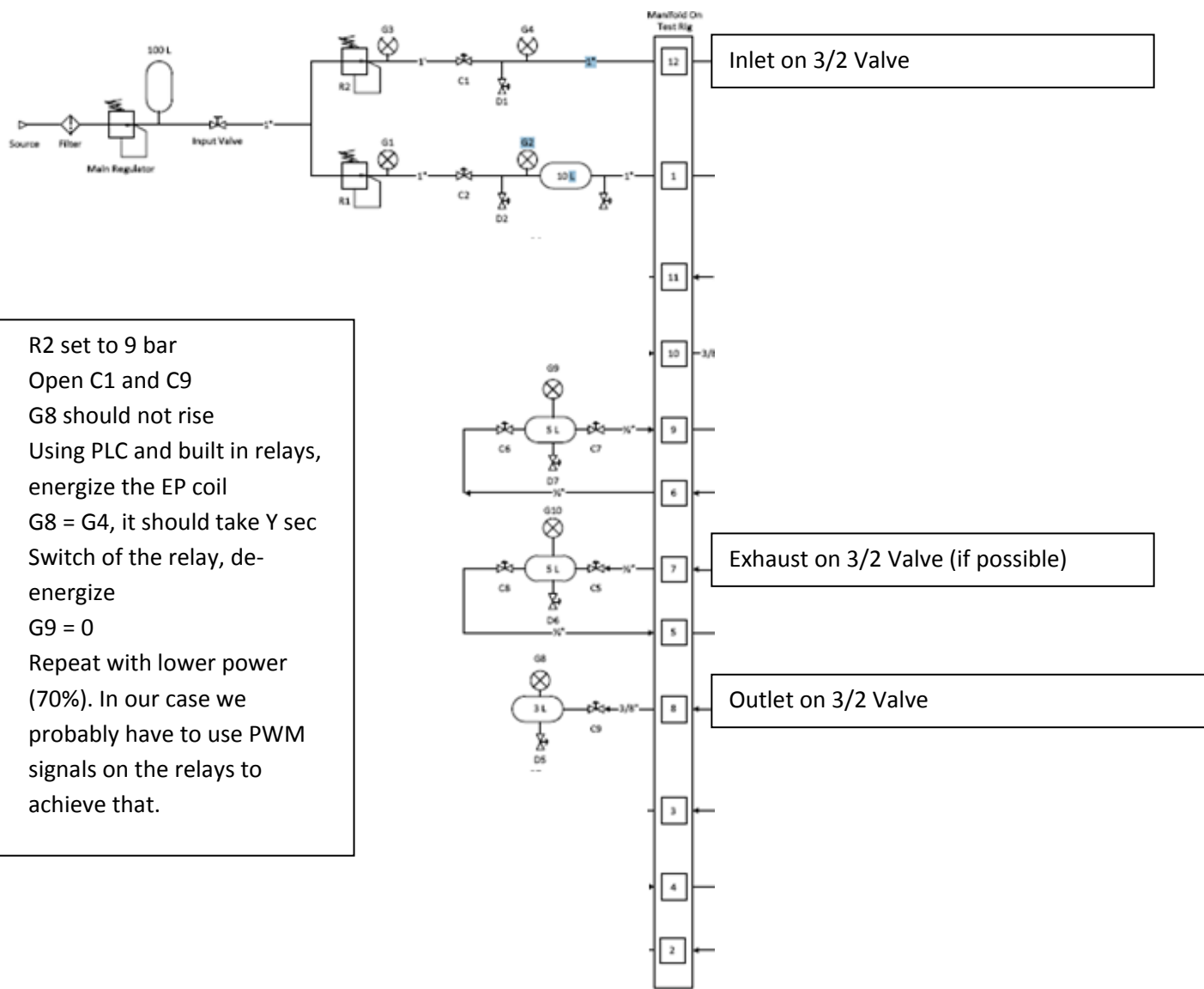

Figure 39. Installation of the 3/2 EP valve.

6.1.12 Distributor Valves

The distributor valves are pilot controlled by pressure which is connected through control port. Normally there is 5 bar in the control port which makes the valve closed. If the pressure in the control port drops, the air from the inlet will go through the outlet. The pressure in the outlet will increase and keep increasing if the pressure in the control port continues to drop.

This valve has three Ports:

- Control port
- Outlet
- Inlet.

For example, control port = 5 leads to outlet = 0, control port = 0 leads to outlet = full (no restriction between MR and out). Connection between inlet and outlet will start at control port = 3.5 bar.

6.1.12.1 Test Specifications and Requirements

There are some initial settings procedures that require a person to do, for example adjusting the screws, so correct pressure is achieved. These are described in (23).

There are different kinds of performance tests and they are all described in the document mentioned above. The names of the tests are mentioned below.

- BC Filling Time
- Max BC Pressure
- BC Release Time
- Sensitivity
- Minimum Brake Pipe Reduction
- Gradual Braking
- Gradual Release
- Air Tightness
- Proportionality

Most of the distributor valves are about the same, they will have a maximum of 4 ports and by measuring the pressure on each port it will be possible to do a performance test. But there is one type of distributor valve that needs a physical movement step. Right now it is done by an actuator. This makes the distributor valve different from the rest. These valves have to be studied much closer before any statement or decision can be made. For more information about the routine test specifications, see (23).

6.1.13 Emergency Exhaust Valve

The emergency exhaust valve is pneumatically controlled together with a spring. The valve is closed as long as the pressure in the inlet is lower than a certain value. If the control port has lower pressure than the inlet and the inlet has a higher pressure than X bar, the air from the inlet will exit from the outlet.

This valve has three ports:

- Inlet
- Control Port
- Exhaust

6.1.13.1 Test Specifications and Requirements

Table 12 is a summary of the steps for testing the emergency exhaust valve accordingly (24). For the exact instructions on how to test the valve, see (24).

Table 12 Test specifications for emergency exhaust valve

Inlet (bar)	Control Port (bar)
5	Slowly rising to 5
0.827	0

6.1.13.2 How to Test with the DMRC Test Rig

The endurance test is possible to perform, however the performance test is not possible if the values are not recalculated. This requires additional work and the conclusion for this valve is therefore that it is not possible to do the performance test.

Tests planned to perform:

- Endurance

Figure 40 presents a suggestion on how to install the valve in the DMRC Test Rig to allow it to be endurance tested.

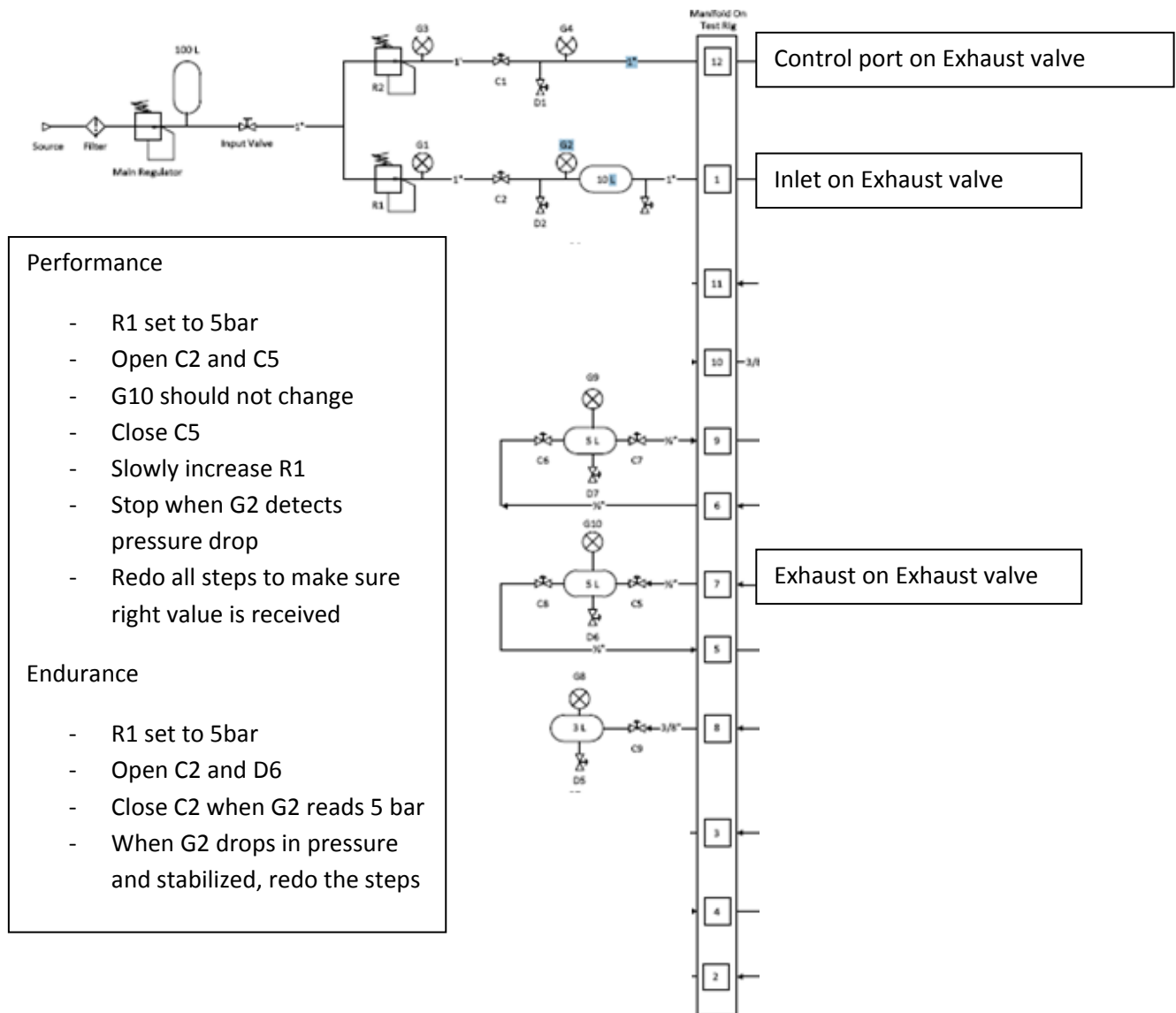

Figure 40. Possibly installation on emergency exhaust valve.

6.1.14 Drivers Brake Valve

Drivers brake valve is completely manually operated. Using the handle will switch the valve between three modes. First mode will lead the air from the inlet to the outlet. Second mode will close the inlet port and exhaust the pressure from the outlet. The third and last mode will hold everything, meaning shutting all the ports.

This valve has three ports:

- Inlet
- Outlet
- Exhaust

6.1.14.1 Test Specifications and Requirements

This valve is different from the others due to needs of manual moments. The construction of this valve needs to be studied closer if the tests should be made automatically. The conclusion is therefore, it is not possible to perform tests on this valve with the DMRC Test Rig without modifications. The expected values in each mode are presented in Table 13. For more information about drivers brake valve, see (25)

Table 13. Specifications on drivers brake valve.

Inlet	Outlet	Exhaust
"FILL"		
Inlet = Outlet	Outlet = Inlet	0 bar
4.5 bar	4.5 bar (4.1 bar within 1.2 – 3 sec)	0 bar
"HOLD"		
4.5 bar	4.5 bar (not drop more than 0.07 bar in 5 min)	0 bar
"VENT"		
-	0 bar (4.5 to 0.4 bar should take 3 – 6 sec)	Above 0 bar

7 Generating Concepts

Most of the methods and steps for generating concepts have been taken from (2). Generating the concepts was not easy since there were many aspects that had to be taken into consideration. Every valve is unique. Other branches than pneumatics has been looked into without any results. This is a quite well-aimed problem and there are not many other branches that can solve this problem. There is one branch that has been studied closely which is the hydraulic branch. Unfortunately most of the testing in that branch basically works the same as its being done now, with manual operated rigs.

Rivals such as Knorr Bremse and Westinghouse have been investigated but also there without any positive results. These companies do not reveal their testing methods. Possible testing methods have been searched for in the patent data base but neither did they have anything useful. This does not give much more options than to generate own ideas.

After studying the valves some basic conclusions could be made:

- All ports on each valves need pressure transducers to be able to capture the data
- Reservoirs are needed on each line to be able to measure the volume flow
- Valves are needed to be able to control the air to and from the ports

The following concepts where built after these criteria.

7.1 Concept 1

In this concept the valves are tested individually which means there will be a 2/2 valve on each port to control the air flow. The valves are tested in parallel, for example if this rig is built for testing 3 valves, 3 valves will be tested in the same time and eight 2/2 E valves have to be installed for every valve which is going to be tested. $8 \times n$ 2/2 E valves is needed, where n is the number of valves which is going to be tested.

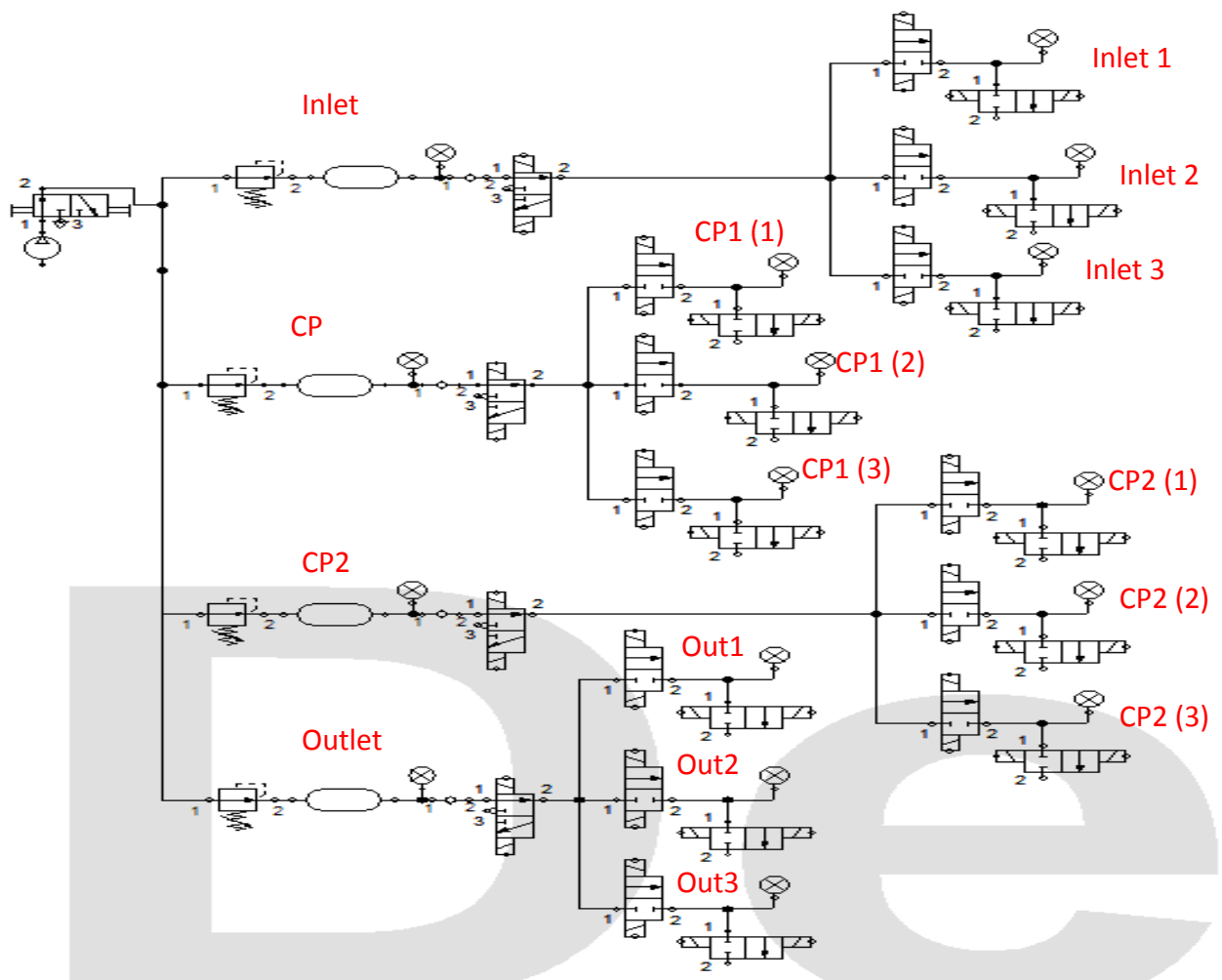

Figure 41. Concept 1.

7.2 Concept 2

This concept has limited the amount of valves installed in the rig. Therefore it cannot capture data from every valve itself because the ports on each valve are linked to each other without any restrictions. In this concept, the DMRC Test rig can only run the endurance test. At the end of the test, employees have to manually do the performance test on every tested valve. This concept is similar to how it is being done today. The advantage compared to how it currently is being is that the rig does not need to be rebuilt after each valve change. Since the data cannot be captured individually on each port on the valves, during the test, no one knows how the valve performed during the cycles. The amount of valves and components needed for this rig is minimal. Figure 42 presents a pneumatic schematic of the concept showing how it would look like when 3 valves are being tested at the same time.

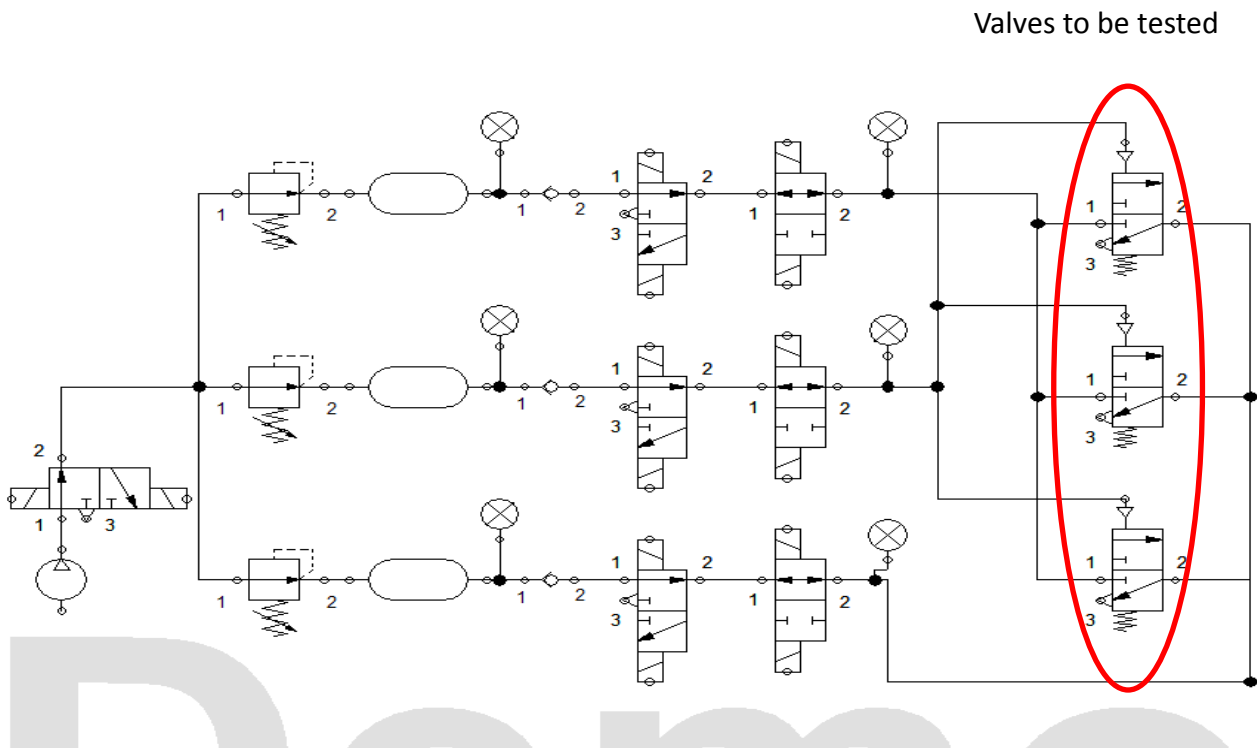

Figure 42. Concept 2.

7.3 Concept 3

Each valve is tested sequentially and the data is captured individually. If this rig is built for three valves and three valves is going to be tested, it will take 3 cycle time for the rig to run 1 cycle on each valve. Compared to Concept 1, this concept has fewer valves but it will be slower. Figure 43 presents a pneumatic schematic of this concept. The schematic is made for 3 valves.

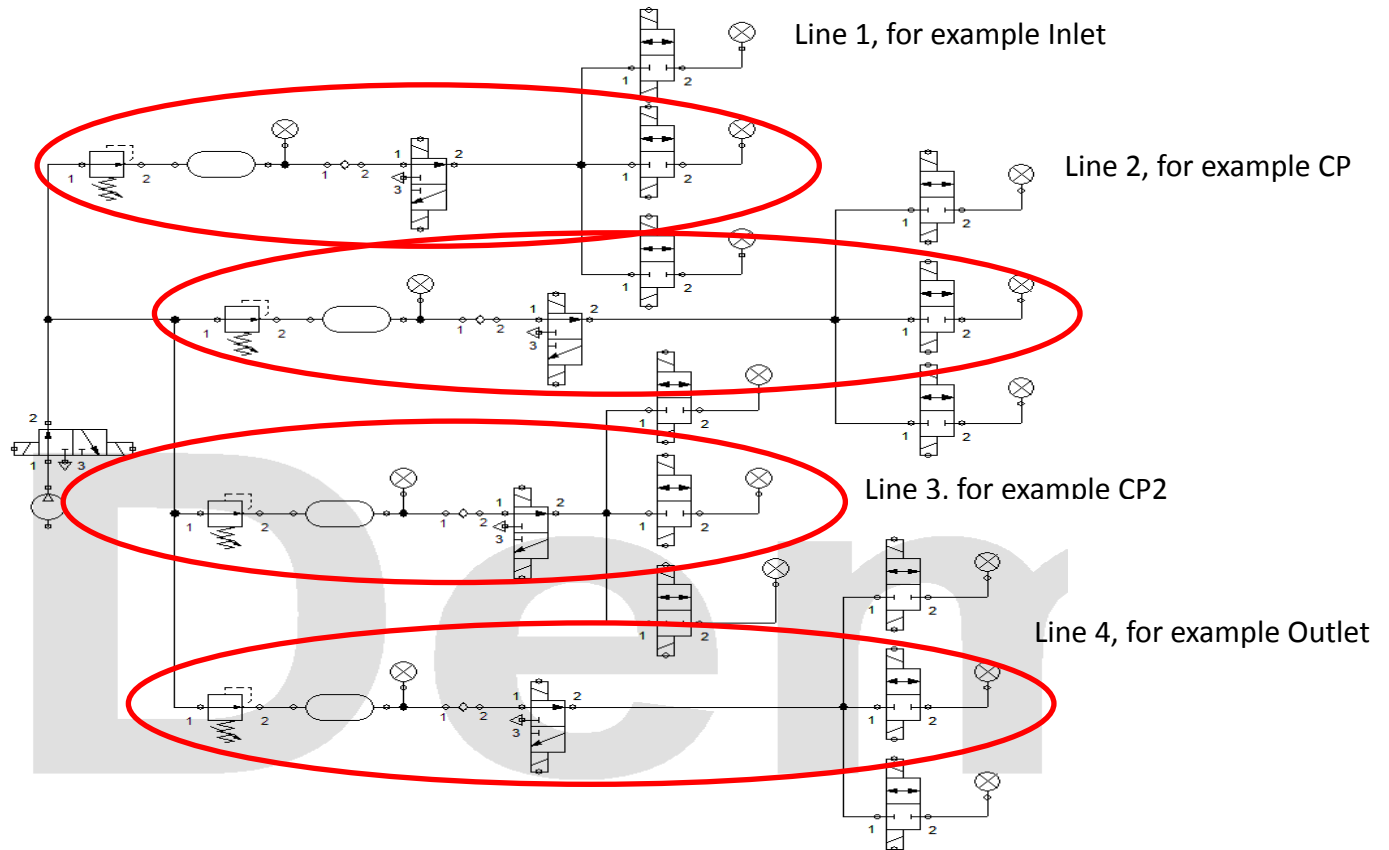

Figure 43. Concept 3.

7.4 Concept 4

Keeping the original design of the rig and find ways to test the different valves. Most of the work is already done in the study process. The possible valves are explained in section 6.1.

8 Improving and Choosing Concept

After a presentation of these concepts it was decided not to change the DMRC Test Rig too much. The presentation was made for the engineers in the R&D department. The time is limited and leaving a project half done is not an option. Therefore the main purpose of improving the concepts has been trying to fit them into the DMRC Test Rig with the least amounts of modifications possible and at the same time trying to achieve the objective.

8.1 Concept 1

Just by looking at the schematics it is possible to see this concept is very difficult to achieve because of the amount of valves which is required. It will require major changes to the DMRC Test Rig to apply this concept.

8.2 Concept 2

Choosing this concept will not make much of a difference compared to what they are doing already. But it can easily be applied by splitting some tubes on the DMRC Test Rig. The schematic will basically look the same as it is shown in Figure 44. More tubes and connections can be added in parallel to the end of each manifold (marked 12, 1 etc.) to fit more valves.

8.3 Concept 3 and Concept 4 Combined

Concept 3 was very similar to the DMRC Test Rig and could therefore be combined with Concept 4. The lines in Concept 3 are similar to the existing lines on the DMRC Test Rig. By ignoring the tubes to the right side of the manifold and installing the valves to be tested as presented in Appendix B, it will be possible to test most of the valves without any bigger changes to the rig. An example would be that the first two lines will work as inlet and control port while the next three lines can work as outlet and exhaust. The only disadvantage would be that it is only possible to test one valve at a time.

After studies of the valves, see section 6.1, it was possible to determine which valves are possible to test using this concept. The following valves which can be tested, without any physical changes to the DMRC Test Rig, are mentioned below.

- Variable pressure regulator
- Single port relay valve
- Double port relay valve
- Check valve
- Duplex check valve
- Auto drain valve
- 2/2 EP valve
- 3/2 EP valve
- Emergency Exhaust Valve

8.4 Choosing Concept

The decision, which concept to choose, was made together with the R&D team. Concept 3 combined with Concept 4 was chosen. The reason why the others were discarded and why the chosen concepts were chosen is explained below.

Concept 1 is too complex and therefore discarded. Choosing this concept will result in major changes to the DMRC Test Rig due to the amount of 2/2 valves required. This leads to a lot of work and takes a lot of time.

Concept 2 was discarded because of the data loss. The data from the tests will not be of good quality since the data is not from the individual valves. The data is common between all the valves and could be affected by valves that fail. This means there will be no guarantee that the valves have been functioning during the whole test. The change also will not have enough benefits compare to how it is being done currently. Therefore the change is not worth the effort.

Concept 3 and Concept 4 leads to no modifications to the rig. Only programing and a valve mounting manifold were required. A lot of time would be saved by choosing these concepts combined. However there is a catch, choosing these concepts will result in that all the valves cannot be tested and only one valve can be tested at once. But this was accepted by the R&D department so the final concept is Concept 3 and Concept 4 combined.

9 The new DMRC Test Rig Build

The new construction, how it intends to work and the process of adding new valves to the test are explained in this chapter. The schematics for this rig still remain the same, as the physical/electrical structure of the rig has been kept as its original. Most of the changes made to the rig lie in the Ladder programming, where a completely new code has been written. Another big change is the way the DMRC Test Rig is being used.

The valves which have been added to the DMRC Test Rig are the single port relay valve and check valve. When connecting these valves to the rig, it is important to get the connection right. Depending on the valve, different lines are programmed to function as Inlet, Control Port, Exhaust or Outlet. This cannot be changed without changing the Ladder code. As the lines have been assigned a function each, such as inlet, outlet etc. they are programmed to follow the steps written in the routine test specification. Routine test specification is the technical document which every valve has and explains how the test should run. To add a new valve new Ladder code has to be written and added.

9.1 Pneumatic Schematic

In Appendix B, there is a schematic explaining what the different lines in the DMRC Test rig should be used as. The way the lines are structured in the schematic is the easiest way to test the valves. For some valves it is the only possible way to perform the tests. Line 3 can be used if the valve requires an additional control port or anything that needs a certain fixed pressure. On the schematic there are also additional ports on the rig which can be used for measuring, exhausting etc. It all depends on the needs.

9.2 Adding New Valves

There are no strict rules on how to add new valves. The important part is that it should work mechanically and pneumatically. Basically line 1 and 2 works best as control port and inlet because they have a pressure regulator connected directly to the main air supply and a reservoir. The other lines serve other purposes such as outlet and exhaust. There are many ways to add new valves to the rig but the best way is to follow the steps shown below.

1. Study the valve pneumatically and find out what pneumatic component is needed. When the study part is done take a look at the pneumatic scheme and see which lines can fulfill its needs and connect it that way.
2. Start programming. Follow the Routine Test Specification to know the pneumatic steps required and program the different lines to follow these steps. During the programming, see which CALL Functions are already there so time will not be wasted.

As mentioned before, this rig cannot run leak tests because of the leakage in the cocks, in line 1 and 2. These cocks have to be changed to 100% leak proof valves if there is a need of doing leak tests.

10 Testing of Single Port Relay Valve

There was only enough time to write the codes for the check valve and single port relay valve. Check valve is too easy and not interesting enough to test, so the test will neither be described nor run. In this chapter the focus lies in describing the tests done on the single port relay valve. The data will be presented, analyzed and conclusions will be made out of the 70 cycle test.

The original standard endurance test is supposed to run 1 million cycles. This test is just to show how it is intended to work and how the data can be applied and used. The 1 million cycle test can use the same principles as for the 70 cycle test which is described in this chapter. The reason 70 cycles was used was because of time limitations and the amount of data to present which would make it too much. The valve was also supposed to be mounted according to a certain document which it had not been. There was not enough time to design and produce the valve mounting manifold.

10.1 Tests

The test planned to perform is part of the performance and endurance test. The leak test is included in the performance test but it has been excluded because some valves in the DMRC Test Rig are leaking which has made it impossible. Performance test also includes the “warm up” of the valve, where the valve has to run for approximately 5 cycles so the components inside the valve get into position. The endurance test works as putting the performance test into repetitive cycles. It will run a total of 1 million cycles and it will collect data from each cycle from every port on the valve. Unfortunately there is no manifold to connect the valve to which means the valve hangs loose on the connecting tubes until further.

One cycle of the performance test is described below. The following numbers below show the applied pressure on the control port. After each step, 2-8, data is captured from the transducers in the outlet, control and Inlet port. It is too difficult to match the pressure exactly under the falling pressure which means that the pressure will only be approximated, marked “~” bellow, during those circumstances. However this is not a problem for the test, technically the test is still the same, for example if the control port has the pressure 2.23 bar from decreasing decreasing pressure, the outlet should have 2.23 ± 0.1 bar. This means the control port does not have to be at exactly 2 bar but it should be near to that value.

1. 0 bar
2. 1 bar
3. 2 bar
4. 3 bar
5. 3.5 bar
6. ~3
7. ~2
8. ~1
9. 0

10.2 Connection/Assembly/Schematics

As it was mentioned before, there are no strict rules saying how the lines should be used. With logical thinking it is understandably easier to control the pressure in a tube if there is a volume installed, for example it is easier to control the pressure in line 2 than in line 1 because line 1 does not have a volume. This means line 2 should work as control port. As it is now line 1 is used as control port and it does not have volume. The reason why line 1 is used as control port and not as inlet is because there was not any 1" tube which could be used for connecting the main air supply to the rig. Instead a 3/8" tube was used. The small tube caused a bottle throttling and affected the results and the speed. So instead line 1 had to be used as control port and line 2 as inlet because the inlet needed a volume to prevent the bottle throttling. The lines can easily be changed back in the future when a proper tube is used instead. Figure 45 shows the pneumatic schematic on how the single port relay valve is connected to the rig.

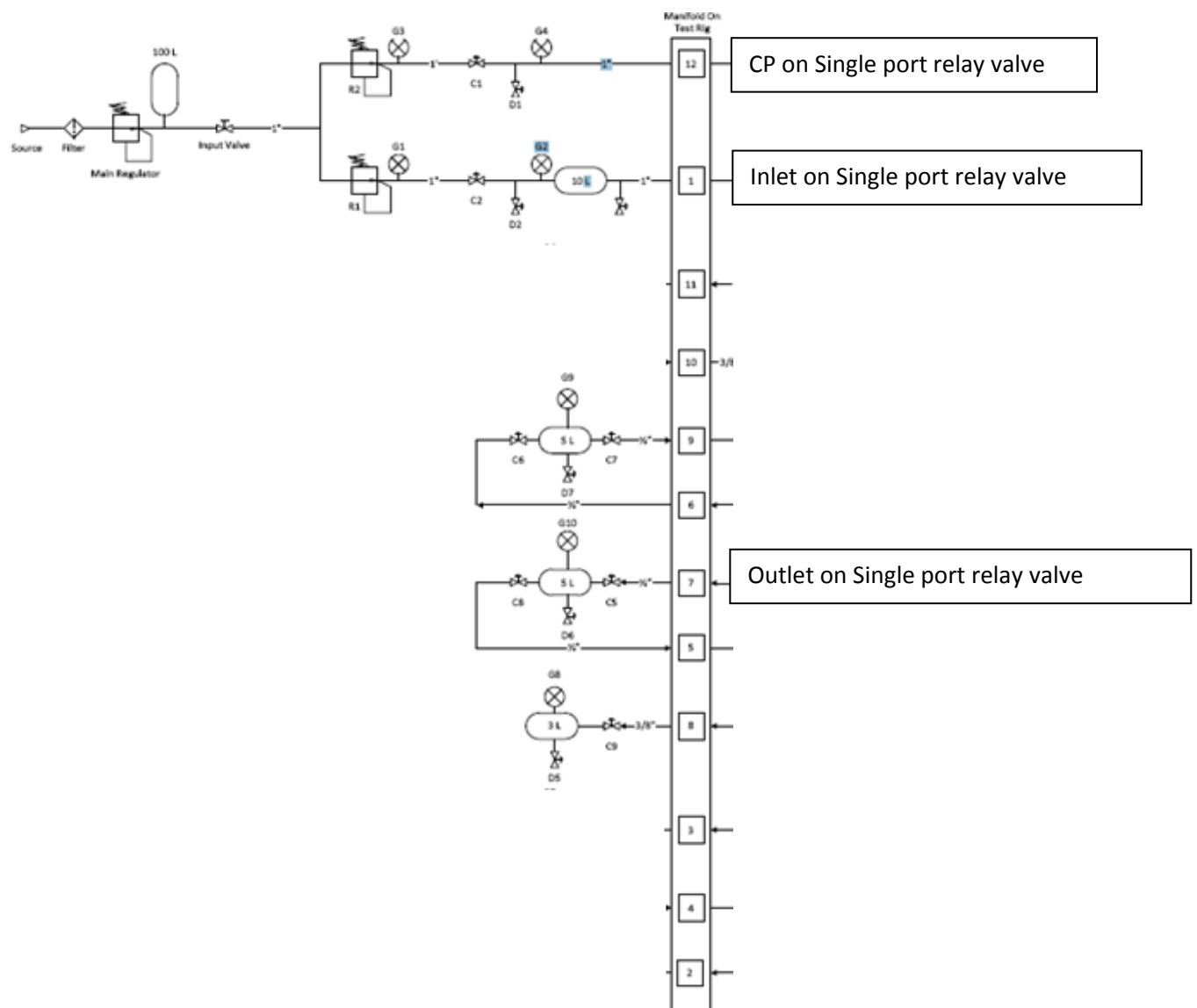

Figure 44. Schematic on testing SPRV.

10.3 Captured Data

All the collected data is stored in text files and stored in such a way that the data, from the control and outlet port, are split up between 4 text files each. For each stage, 1 bar, 2 bar, 3 bar and 3.5 bar, there is a text file for the transducers as presented below.

- Outlet G10P1.txt ControlPort G2P1.txt (1 bar)
- Outlet G10P2.txt ControlPort G2P2.txt (2 bar)
- Outlet G10P3.txt ControlPort G2P3.txt (3 bar)
- Outlet G10P4.txt ControlPort G2P4.txt (3.5 bar)

G10 and G2 refer to the transducers in the pneumatic schematic.

The tolerance on the single port relay valve depends on if the value is captured when the pressure was increasing or when it was decreasing. The stored data is not ordered in such a way. If the transducer from the control port and the text file “ControlPort G2P1” (Data from the transducer in control port at 1 bar) are taken as an example. The first time the transducer stores a value in the text file will be during increasing pressure. Next time it stores a value will be when the pressure is decreasing. Every data stored in an even row, 2, 4, 6 etc. will be during decreasing pressure. The rest will be during increasing pressure. Sorting the values in the text files can easily be done in for example Excel with the function modulus by setting it to 1, 0, 1, 0 etc., and then use the built in filter in Excel. Table 14 shows how the first 4 values from the text files “G10P1.txt” and “G2P1.txt” are sorted up using modulus, so the differences could be calculated and stored in column “P1 Up” and “P1 Down”. The values are in bar.

Table 14. Example of modulus in Excel.

Num	Mod	CP P1	Out P1	P1 Up	P1 Down
1	1	0.872	0.8325	-0.0395	
2	0	1.004	1.0175		0.0135
3	1	0.924	0.885	-0.0390	
4	0	1.008	1.0225		0.0145

10.4 Analysis of Data

According to (14) the difference in pressure between the control and outlet port can maximum be +0.05, -0.15, when the pressure is increasing and ±0.1 when the pressure is decreasing. It means that if 2 bar is applied to the control port, the outlet must have a pressure in the range 1.85 – 2.05 bar if the pressure was increased from <2 to 2 (less than 2 bar to 2 bar) bar and 1.9 - 2.1 bar if the pressure was decreased from >2 to 2 bar (more than 2 bar to 2 bar). The formula to calculate the captured values should therefore be “current outlet pressure” – “current control pressure”. Table 14 shows the calculations of the first four values. Take first row as an example, “Out P1” – “CP P1” Equals to the value in “P1 Up”.

Table 15 shows the most extreme values which were captured and also the mean value from the 70 cycles, for example in “Stage 1 bar, Increasing Pressure”, the absolute lowest pressure was -0.0555 bar,

the absolute highest was -0.039 bar and the mean value was -0.0493 bar. The functions MAX, MIN and Mean were applied to the columns, with the captured data, in Excel. Table 15 presents the results after the functions were applied.

Table 15. Data analysis.

Stage (Bar)	Lowest	Highest	Mean (70 Values)	Tolerance	Transducer Accuracy incl.
Increasing to 1	-0.0555	-0.039	-0.0493	-0.150 - 0.050	-0.113 – 0.015
Decreasing to 1	0.0135	0.022	0.0174	-0.100 - 0.100	-0.071 – 0.0693
Increasing to 2	-0.076	-0.0565	-0.06312	-0.150 - 0.050	-0.113 – 0.015
Decreasing to 2	-0.043	-0.03	0.03719	-0.100 - 0.100	-0.071 – 0.0693
Increasing to 3	-0.0945	-0.075	-0.08459	-0.150 - 0.050	-0.113 – 0.015
Decreasing to 3	-0.0955	-0.077	-0.09146	-0.100 - 0.100	-0.071 – 0.0693
Increasing to 3.5	-0.107	-0.0855	-0.09759	-0.150 - 0.050	-0.113 – 0.015

No environmental disturbance occurred during the test and the programmed code ran smoothly. Also the data in different stages were kept in a certain range which looked reliable. This can be seen in Figure 46. Although the valve was not mounted properly, it still worked perfectly. In the graph, presented in Figure 46, the round dotted marks is the captured data. The color defines at what pressure the data was captured. The lines with different color are the mean pressure from all the data captured in that stage. The x-axis presents the number of cycles and the y-axis presents the pressure difference between the control and outlet port.

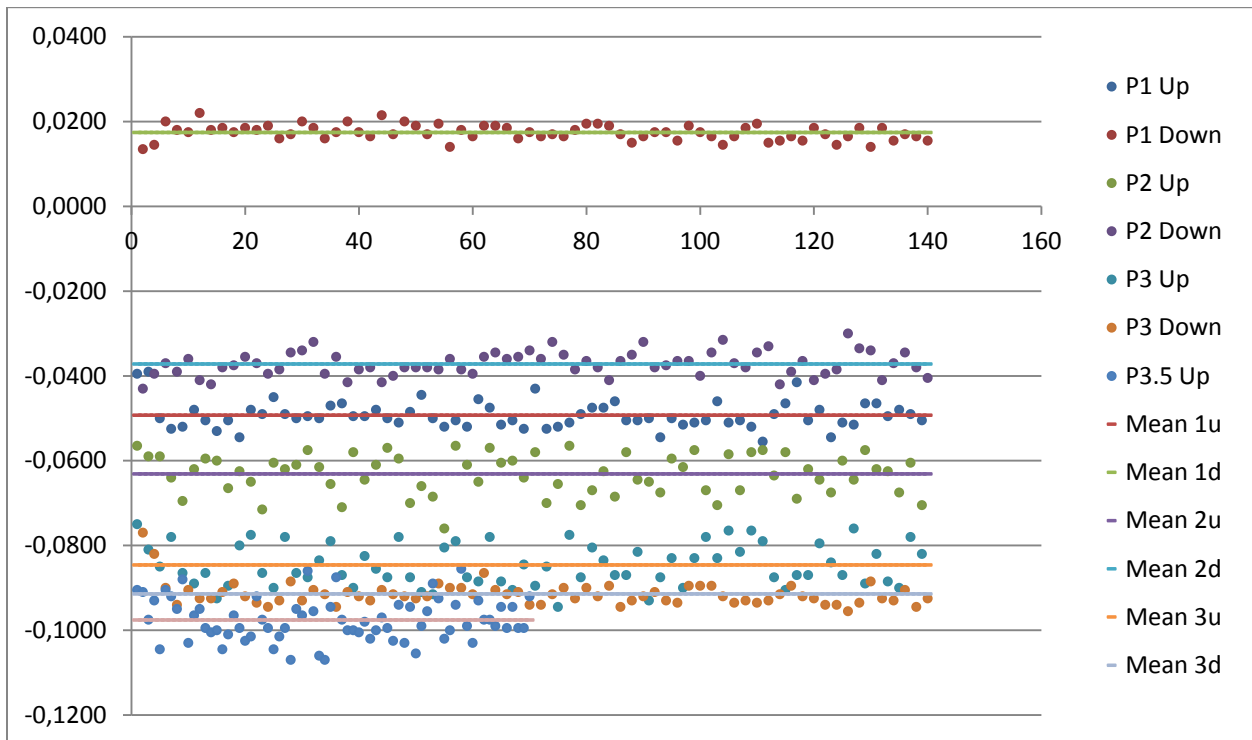

Figure 45. Plotted graph of the captured data.

10.5 Conclusion

The presented data clearly demonstrates how the variance is increased the higher the pressure becomes. According to (10), only temperature can affect the accuracy of the transducer. Since the test only ran during the day and not over the night, the temperature differences were not big and did not affect the data. Only the way the valve was mounted could have affected the data but since the data was not randomly set the, way the valve was mounted probably did not affect the data. The captured data can be considered as reliable but still a valve mounting manifold has to be designed and manufactured because the valve has to be properly mounted.

Table 15 shows that all the values are within the tolerance range. However the test only includes 70 cycles which does not make this test 100% completed, as the original endurance test needs at least 1 million cycles. Because the test only ran 70 cycles, this test cannot guarantee that the same valve will perform as good as if it were 1 million cycles, so this has to be taken into consideration. One cycle takes approximately 30 seconds to perform with the current code without optimization which means that it would take 347 days to do the full test. There was not enough time for that. The calculation can be seen below. All the data from the 70 cycles are plotted in graphs and it can be seen in Appendix C.

$$\frac{1000000 \text{ (Cycles)}}{24(h) * 60(\text{min}) * 2(30 \text{ sec})} = 347.222$$

If the transducer accuracy is included the valve might not pass the test. The measured values for 3 bar during decreasing pressure are outside the tolerated boundaries. Not even the mean value, -0.09146 bar, is within the tolerated boundaries which is between -0.071 to 0.0693 bar. Overall the values are good.

10.6 Discussion

A way of solving the problem, where the values were not within the boundaries, is to look closer to the accuracy of the transducer. If the accuracy is higher the boundaries will become bigger which might accept these data. Another solution can be changing the existing transducers to more accurate transducers. If this does not work, the problem might lie within the valve or because the valve was not mounted properly.

If the new endurance test on DMRC Test Rig is compared to how the endurance test currently is being done, the DMRC Test Rig takes longer time to perform one cycle. This is due to how it is tested. The code can be changed so the time taken will be the same but then it will not be as reliable as it is now. Currently the endurance test runs in such a way that they only test it at a certain pressure, for example 2 bar on the control port and then the pressure is released and it continues to run like that that for one million cycles. It only checks for the pressure at a fixed value instead of many different. This makes the test faster but less reliable. As mentioned in previous chapters a lot of information was lost using the old test methods. The new way of testing basically repeats the performance test multiple times, which means the valve is tested against 1, 2, 3 and 3.5 bar for each cycles and also when the pressure is decreasing 3, 2, 1 bar. The data is captured during the whole process which currently is not being done.

The new way takes longer time to test but it is a reliable test and the captured data can easily be used to benchmark against other similar products or also to develop and improve the valve.

The current endurance test technically does not guarantee that it will function for all those 1 million cycles. Before an endurance test is run, the valve will first be performance tested so the output values are correct. If the valve passed the performance test, the endurance test will start. After the endurance test the valve will go through a new performance test to see if the values are still correct and within the tolerances. No values are checked during the endurance test which means if the valve for example fails for some cycles and returns to its normal state again after some time it will not be noticed. Or if the valve starts to return false output data for 100 cycles during the 1 million cycles it still will not be detected. It is important to make sure the valve will work to 100% when it carries an important task like being a part of the brake system of a train.

Obviously it takes too long to do the new endurance test. 347 days to perform a standard endurance test, 1 million cycles, is not acceptable. Nobody wants to wait almost a year for the results. This test has to be shown to the customers. Also changes have to be done if there are problems with the valve. This time needs to be cut down dramatically and it can. The test can easily be optimized so it can run much faster. The reason the test was not optimized was because of the tube which was connected to the rig for air supply was causing a bottle throttling. The thickness of that tube was only 3/8" when it was supposed to be 1". If this tube is changed to 1" the test can easily run much faster, probably below 10 seconds for one cycle. This leads to 116 days which is still a very long time but more acceptable. The calculations can be seen below.

$$\frac{1000000}{24(h)*60(min)*6(10\ sec)} = 115.7\ days$$

By comparing the current endurance test method with the developed method, the developed one has several advantages. The developed method basically runs the current performance test automatically every cycle, which means that a manual performance test is not necessary after running an endurance test on the DMRC Test Rig. However the leak test is missing in the DMRC Test Rig and is included in the current performance test. The leak test could not be done because some valves in the rig were leaking. Comparing the time of the different tests the DMRC Test Rig runs them much faster because it is automatic. The current performance test takes approximately two hours to perform but then the leak test is also included. The leak test is only a small part of the current performance test so even if the leak test was excluded this rig still runs the performance test much faster.

11 Further Development

There is a lot to improve on the DMRC Test Rig to make it more functional and user friendly. The rig has great advantages for testing valves where many steps can be automatized and speeded up. This rig can have a great variance in the tests which the existing arrangements does not have. It can test the valves in many more ways than the existing rigs. The captured data from the tests can be used in many purposes such as benchmarking, improving the valves and also for marketing and sales. The limitations are endless. Companies using this technology for testing valves will have great advantages. In this chapter some suggestions of improvements have been added. These improvements are for example optimization, more features etc.

11.1 Valve Mounting Device

Now when the testing works for sure it is important to develop something that the valve can be connected to. There are strict rules how the valves should be mounted which make this mounting device very important. The optimal would be it should be flexible, fit all the valves and easy to assemble the valves to. Chokes could also be integrated into this mounting device which will make it possible to test additional valves such as hose protection valves.

11.2 Features

Some useful features could be added in the Java code. The R&D department had a few ideas, some were just useful and some were necessary. Currently there is a document which has to be filled in and signed for each test. This document presents, for example how the valve has performed and who is responsible. Making a user interface in Java and integrate this document would save a lot of time for the user. The users can write their name in the computer and choose which test to run. When the test is finished it will create a PDF file with the results so it can be printed out. When the document is printed out it just needs a signature from the person who ran the test. This would speed up the whole process compared to the old method, writing everything manually with pen and paper.

Some other features can be to operate the PLC from the PC with more control. More control means for example adding pause, restart, reset, adding more cycles etc. There was not time enough to add these features but it can be done. Some of these features can be added very easily and some are a bit more difficult.

11.3 RS-232 & Ladder code

Both the Ladder code and the Java code have proven to work perfectly but that does not mean that the code is perfect. There are still parts of the code which can be improved. Greater parts of the Ladder code are structured in a good way but it can still be confusing for someone who is not familiar with the code. Below are some structuring examples.

- RS-232 settings for transmission and reception can be put in a more proper place, for example all the settings can be put in the beginning. Now parts of the RS-232 settings are spread everywhere in the code.
- The reception procedure can be shortened and more optimized in SerialRead Thread in Java. Right now it there are a lot of converting which might not be necessary. Some parts can be read directly from the buffer.
- The different tests should be separated with lines and comments so it will be easy to find and update the test in case it is needed to.

11.4 User Interface

It is very important to have a good user interface to make it easy for operators to run the DMRC Test Rig. That means the user interface has to be done properly. It has to be done in a good way so other people can easily understand and use it. There should be no need to teach other people how to use it. It should be that easy so whoever can run the program and start operating the rig. The interface should have the following functions:

- Manually operate every single valve. To be able to follow the measurements from the transducers in real time.
- Be able to choose which test to run. There should also be options for which parts of the test to run and which to be skipped.
- This is not a required feature but an interesting and useful one. The captured data in the test should be possible to plot directly into a graph which updates in real time. This feature makes people who are running these tests more integrated by allowing them to follow the progress.

To achieve these features it is required to program in the Ladder code as well. It makes it necessary for the person to first study the Ladder code before starting to program the user interface.

11.5 Adding more Valves

Adding more valves to the test should be done after studying the Java and the Ladder code. Otherwise the structure of the code might be changed or messed up. Studying the Java and the Ladder code will also help knowing how to add new valves. The process will become much faster and easier.

12 Bibliography

1. **Rydberg, Karl-Erik.** *Basic theory for Pneumatic system Design*. Linköping : Linköping University IKP, Fluid Mechanical Engineering Systems, 1997.
2. **Eppinge, Karl T. Ulrich & Steven D.** *Product Design and Development*. McGraw-Hill/Irwin : 5 edition, 2011. ISBN-10: 007340477.
3. **Mitsubishi.** *MELSEC System Q, Programmable Logic Controllers User's Manual*. Ratingen, Germany : MITSUBISHI ELECTRIC Industrial Automation, 2004. Q64AD, Q68ADV/ADI, GX Configurator-AD. Datasheet.
4. —. *MELSEC System Q, Programmable Logic Controllers User's Manual*. Ratingen, Germany : MITSUBISHI ELECTRIC Industrial Automation, 12 2010. Q62DAN, Q62DA, Q64DAN, Q64DA, Q68DAVN, Q68DAV, Q68DAIN, Q68DAI, GX Configurator-DA. Datasheet.
5. —. *MELSEC System Q, Programmable Logic Controllers User's Manual (Hardware & Maintenance)*. Ratingen, Germany : MITSUBISHI ELECTRIC Industrial Automation, 2003. CPU Modules Q02(H)CPU, Q06HCPU, Q12HCPU, Q25HCPU. Datasheet.
6. —. *MELSEC System Q, Programmable Logic Controllers*. Nagoya, Japan : MITSUBISHI ELECTRIC Industrial Automation, 2003. High Performance Model QCPU (Q Mode) User's Manual. Datasheet.
7. —. *MELSEC System Q, Programmable Logic Controllers User's Manual*. Ratingen, Germany : MITSUBISHI ELECTRIC Industrial Automation, 2007. Digital I/O Modules. Datasheet.
8. —. *MELSEC System Q, Programmable Logic Controllers User's Manual (Basic)*. Ratingen, Germany : MITSUBISHI ELECTRIC Industrial Automation, 2004. Serial Communication Modules QJ71C24N-R2/-R4, QJ71C24/-R2 Gx Configurator-SC. Datasheet.
9. —. *MELSEC System Q, Programmable Logic Controllers User's Manual (Application)*. Ratingen, Germany : MITSUBISHI ELECTRIC Industrial Automation, 2003. Serial Communications Modules QJ71C24(-R2), QJ71C24N(-R2)/(-R4). Datasheet.
10. **Trafag.** *Ralyway Pressure Transmitter EPR*. Männedorf, Germany : Trafag Sensors & Controls, 2006. 8293 Ralyway Pressure Transmitter EPR. Datasheet.
11. **Faiveley Transport.** *Single Port Relay valve Endurance Test Schematic*. Hosur : s.n.
12. —. *DMTS-0139-1*. Hosur : s.n., 2008. Internal Technical Report.
13. —. *DMTS-0142-1*. Hosur : s.n., 2011. Internal Technical Report.
14. —. *TEST SPECIFICATION FOR: RELAY VALVE - AB738-W1 & AB738-T11*. Hosur : s.n., 2008. Internal Technical Report.
15. —. *DMTS-0144-1*. Hosur : s.n., 2012. Internal Technical Report.

16. —. *DMTS-0128-1*. Hosur : s.n., 2008. Internal Technical Report.
17. —. *DMTS-0127-1*. Hosur : s.n., 2009. Internal Technical Report.
18. —. *DMTS-0129-1*. Hosur : s.n., 2009. Internal Technical Report.
19. **Davies & Metcalfe plc.** *AB 221 T1/2 222T1 227 T1 TS*. Cheshire : Faiveley Transport, 1988. Internal Technical Report.
20. **Faiveley Transport.** *DMTS-130-1*. Hosur : s.n., 2012. Internal Technical Report.
21. —. *DMTS-006-1*. Hosur : s.n., 1998. Internal Technical Report.
22. —. *DMTS-0177-1*. Hosur : s.n., 2009. Internal Technical Report.
23. —. *AB736-W18/RS2*. Hosur : s.n., 2006. Internal Technical Report.
24. —. *DMTS-003-1A*. Hosur : s.n., 2003. Internal Technical Report.
25. —. *DMTS-0131-1*. Hosur : s.n., 2012. Internal Technical Report.

Appendix A Schematics

A1 Electrical Schematic

Figure 47 presents the electrical schematic over the DMRC Test Rig which is not used very much in this project.

A2 Pneumatic Schematic

Figure 48 presents the pneumatic schematic over the DMRC Test Rig. Some parts on the DMRC Test Rig have been changed which does not show on the pneumatic schematic. These changes are described in section 3.4.

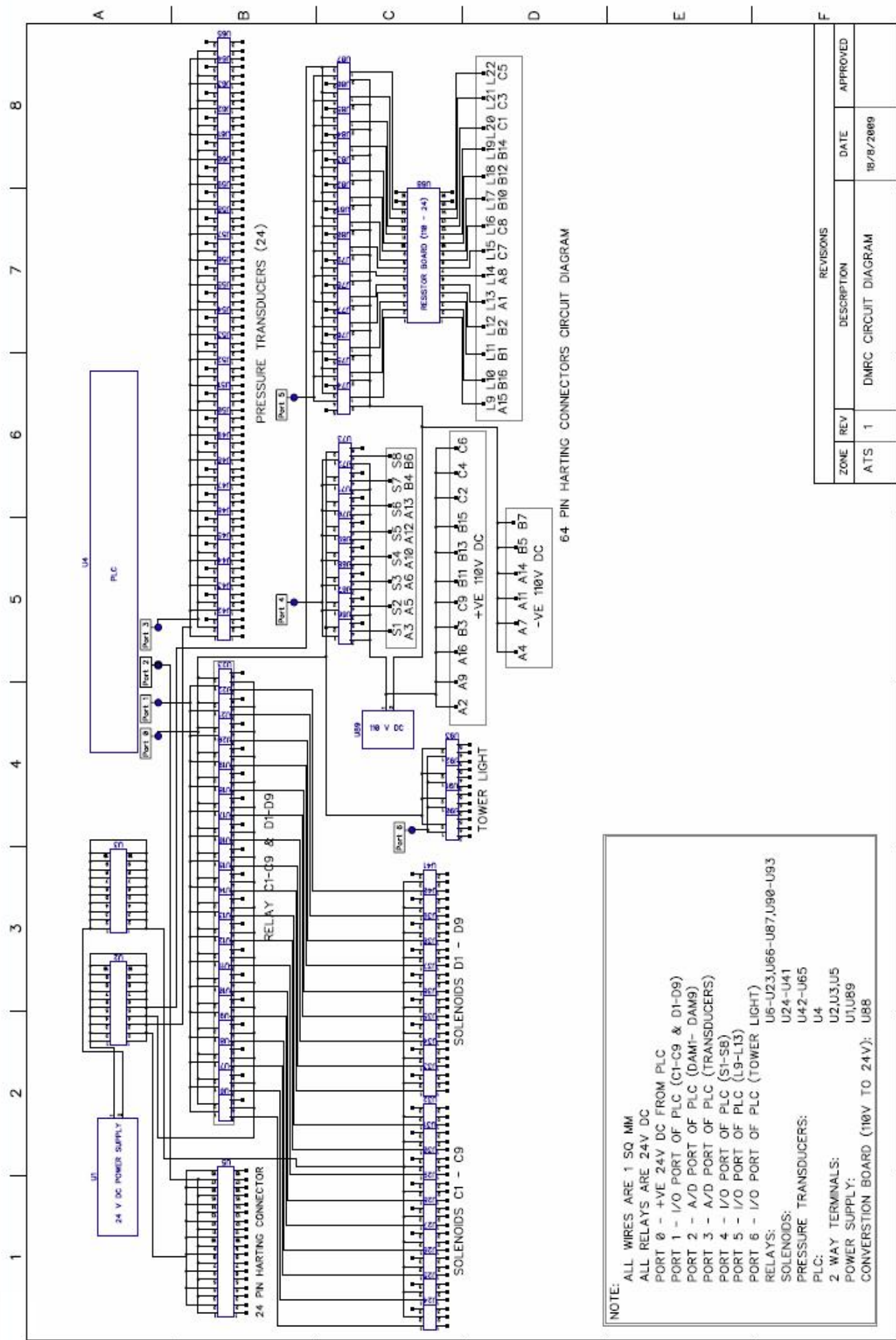

64 PIN HARTING CONNECTORS CIRCUIT DIAGRAM

NOTE:
 ALL WIRES ARE 1 SQ MM
 ALL RELAYS ARE 24V DC
 PORT 0 - +VE 24V DC FROM PLC
 PORT 1 - I/O PORT OF PLC (C1-C9 & D1-D9)
 PORT 2 - A/D PORT OF PLC (DAMI- DAM9)
 PORT 3 - A/D PORT OF PLC (TRANSUCERS)
 PORT 4 - I/O PORT OF PLC (S1-S8)
 PORT 5 - I/O PORT OF PLC (L9-L13)
 PORT 6 - I/O PORT OF PLC (TOWER LIGHT)
 RELAYS:
 U6-U13,U66-U87,U90-U93
 U24-U41
 SOLENOIDS:
 U42-U65
 PRESSURE TRANSDUCERS:
 U4
 PLC:
 U2,U3,U5
 2 WAY TERMINALS:
 U1,U89
 POWER SUPPLY:
 U88
 CONVERSION BOARD (110V TO 24V):
 U88

REVISIONS				
ZONE	REV	DESCRIPTION	DATE	APPROVED
ATS	1	DMRC CIRCUIT DIAGRAM	18/8/2009	

Figure 46. Electrical schematic.

PNEUMATIC CIRCUIT FOR DMRC TEST RIG

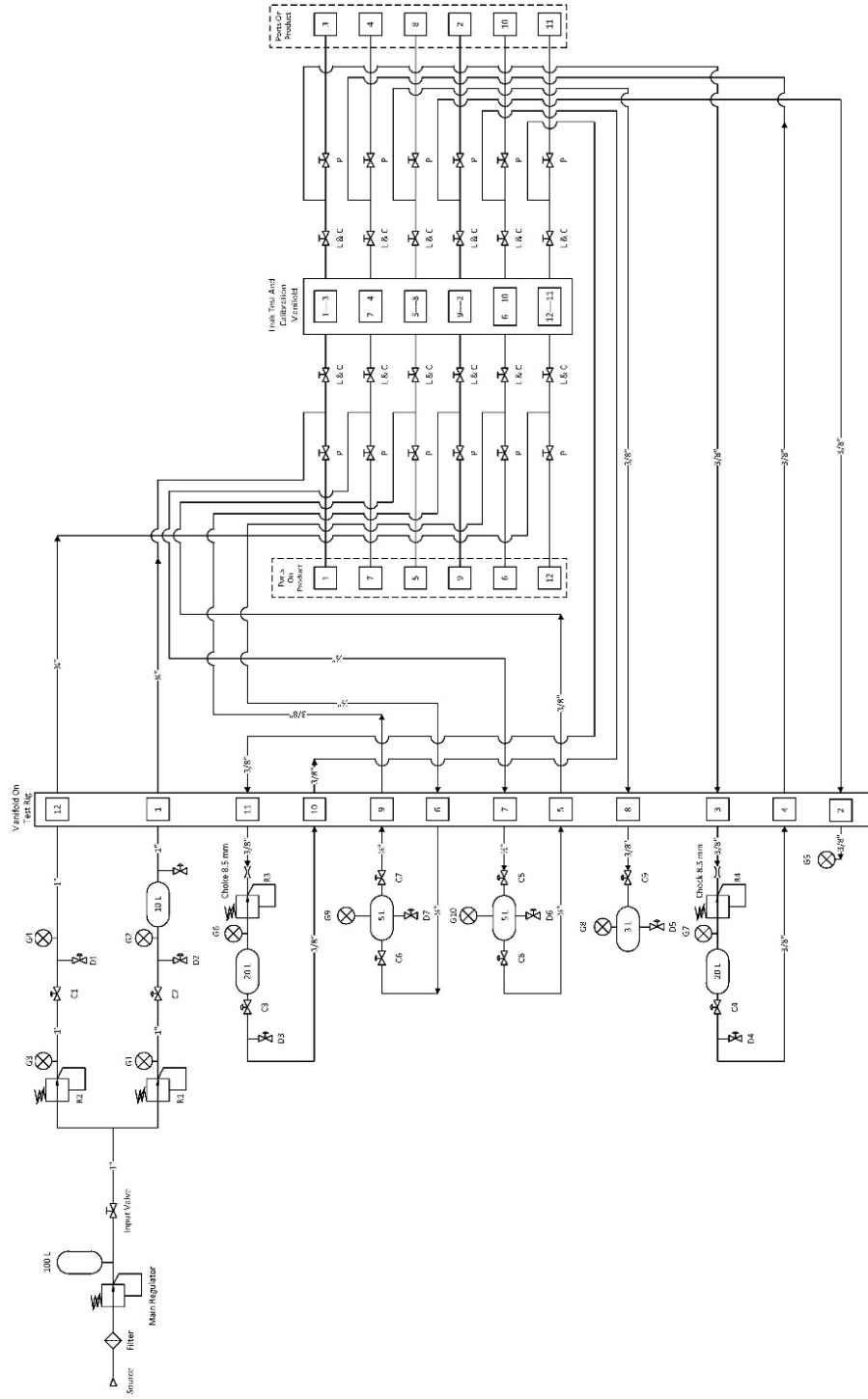

AJANA TECHNOLOGIES
SOLUTIONS PVT LTD

Note:- Please refer Leak Test and Calibration Manual for 'P' and 'L & C' description.

Figure 47. Pneumatic schematic.

Appendix B New Schematic

Figure 49 presents a pneumatic schematic, over the DMRC Test Rig, with notes telling what the various lines and connection are best suitable as for the testing of the brake valves. This schematic can be used for determining which line should be used for which port on the brake valve. There have been some valve changes done to the DRMC Test Rig which does not show on the pneumatic schematic, this is explained in section 3.4.

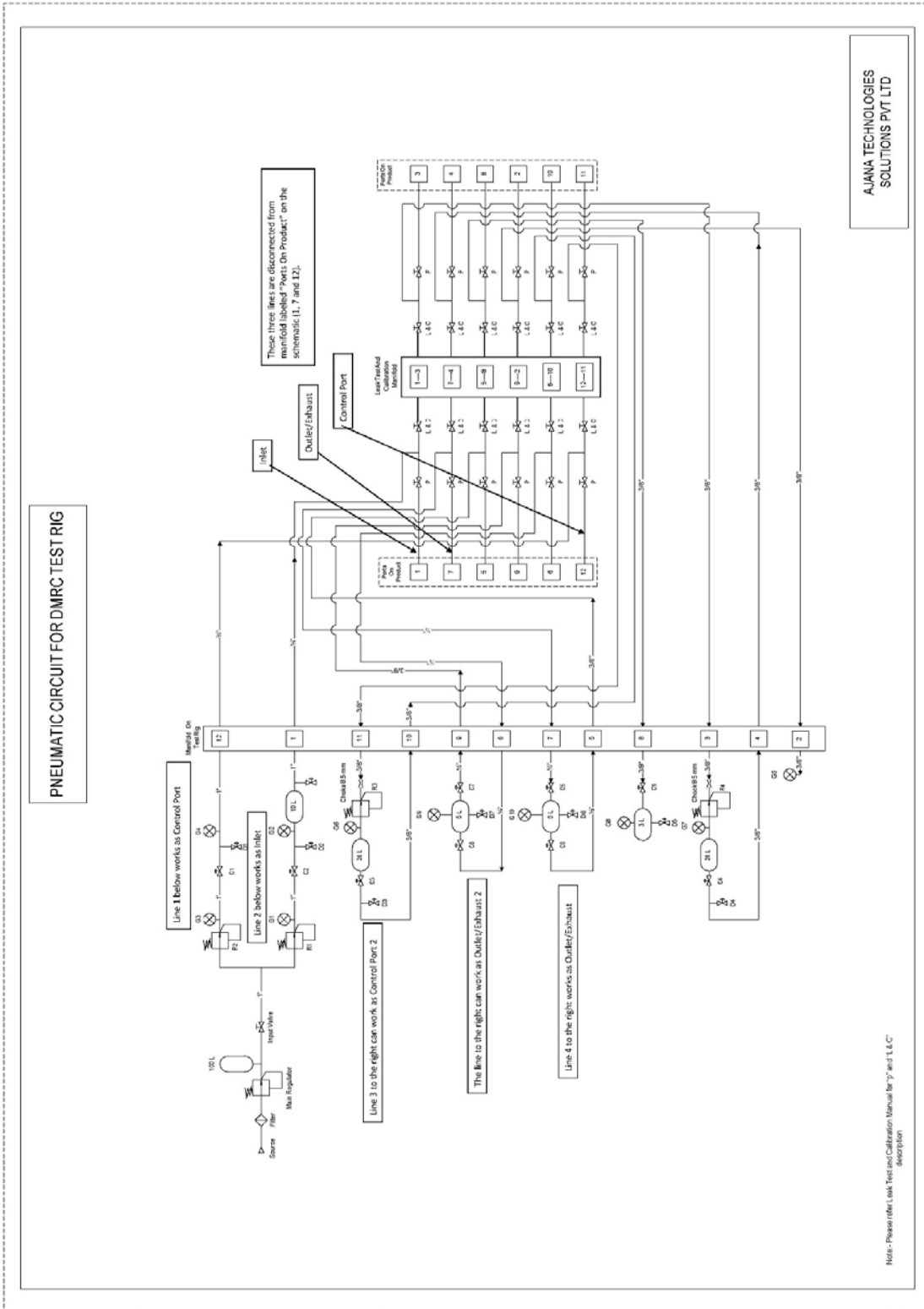

Figure 48. New pneumatic schematic.

Appendix C Captured data during testing of Single Port Relay Valve

In Figure 50 - Figure 54, the round marks are the plotted data and the straight lines are the mean value for each pressure stage. The x-axis presents the number of cycles and y-axis presents the pressure in bar. These graphs presents the pressure differences, in bar, between the control and outlet port from every cycle. These graphs clearly show how the pressure differences are staying in a certain range depending on what pressure the data was captured.

Figure 50 shows all the captured data from the 70 cycle test of the single port relay valve plotted in one single graph.

Figure 51 to Figure 54, presents the plotted data from each pressure stage for the single port relay valve. The pressure stages are 1 bar, 2 bar, 3 bar and 3.5 bar. In each of the stages the data is split into two parts which are up and down, meaning if the pressure data was captured when the pressure was increasing or decreasing. Up means it was captured when the pressure was increasing and down is when it was decreasing.

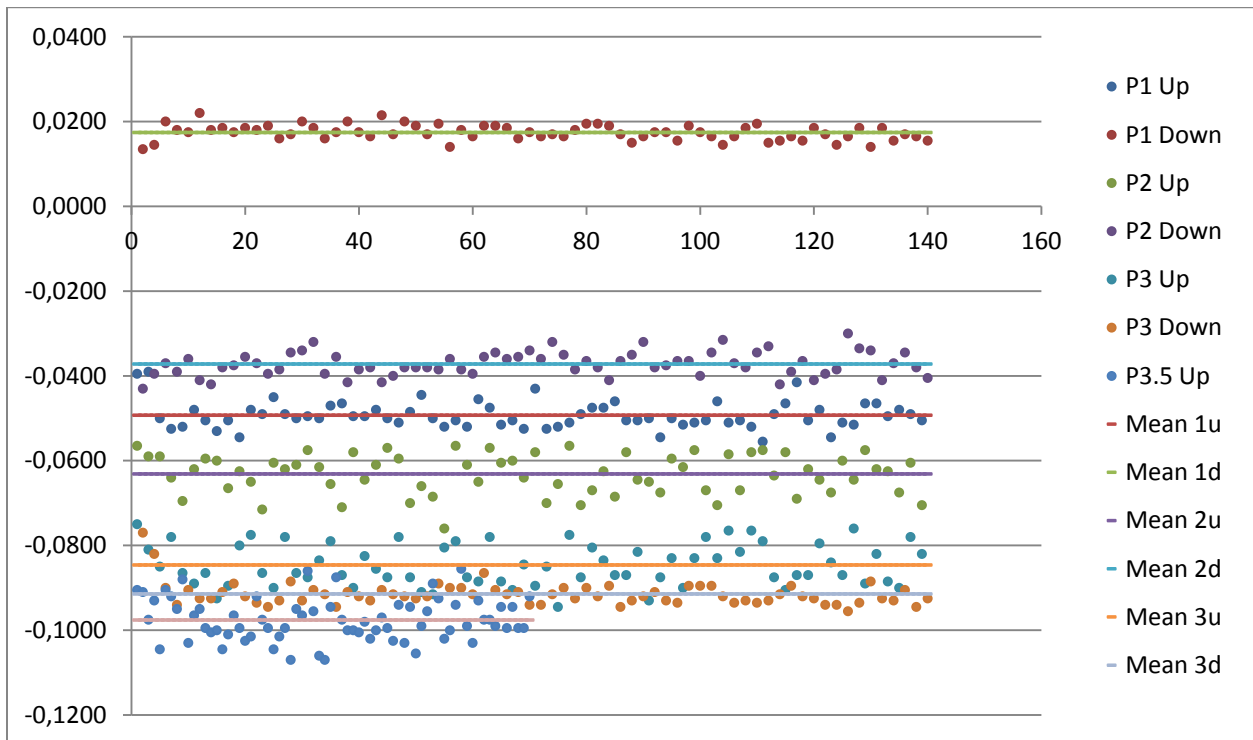

Figure 49. All data graph.

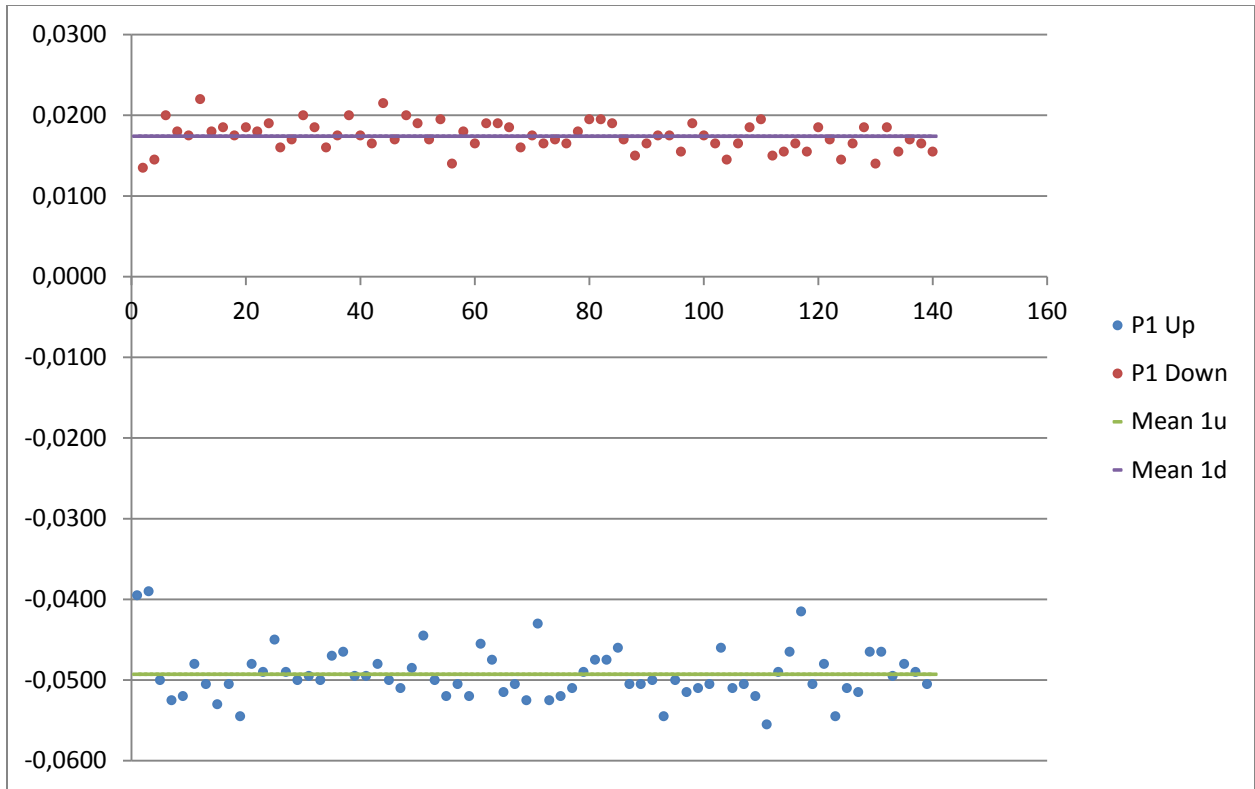

Figure 50. Data at 1 bar graph.

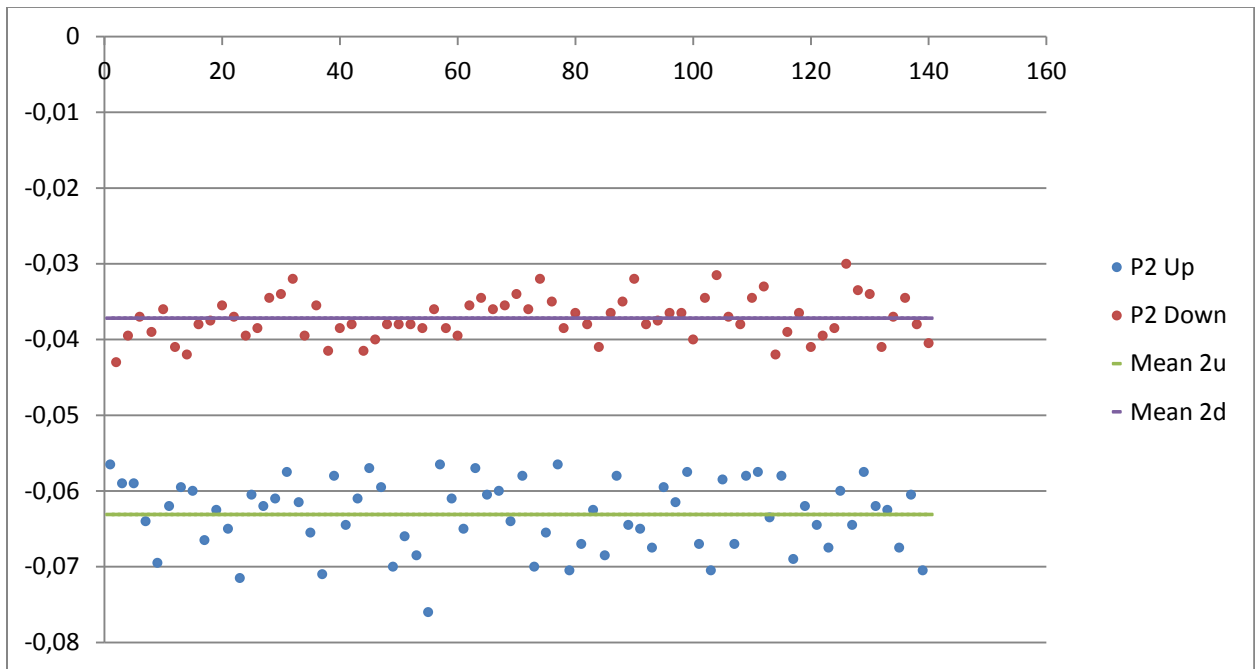

Figure 51. Data at 2 bar graph.

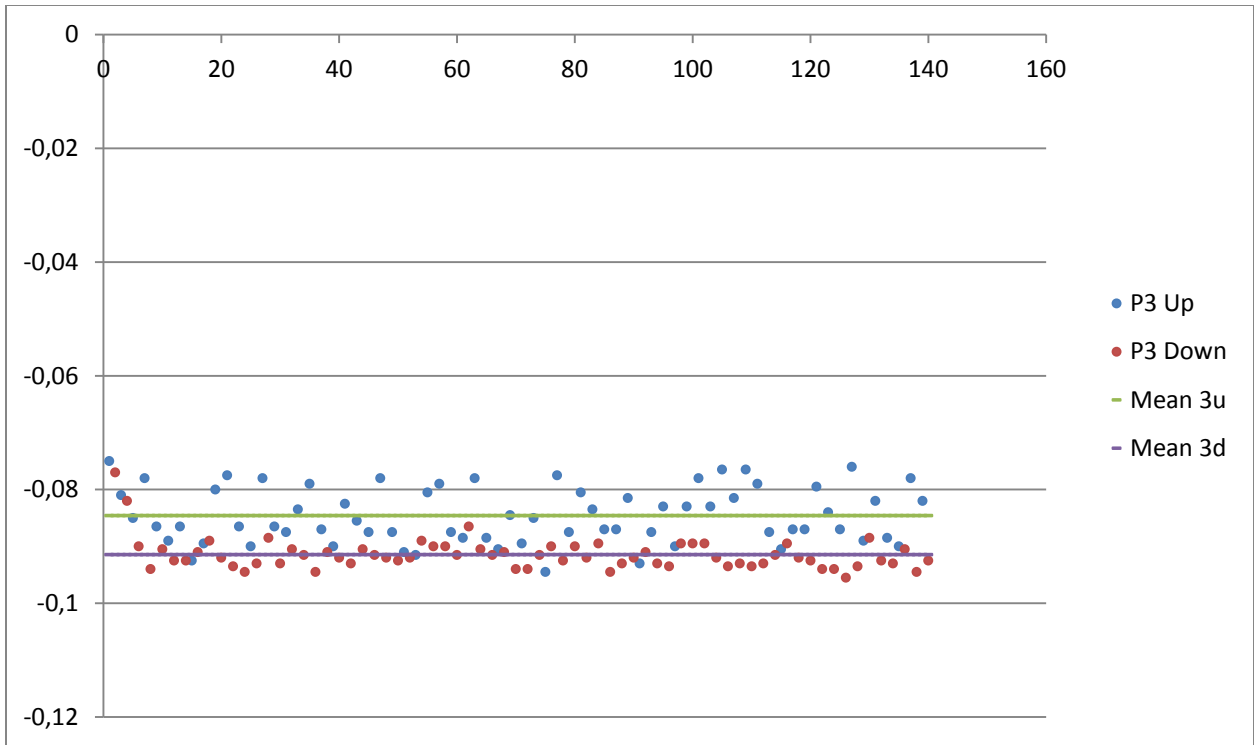

Figure 52. Data at 3 bar graph.

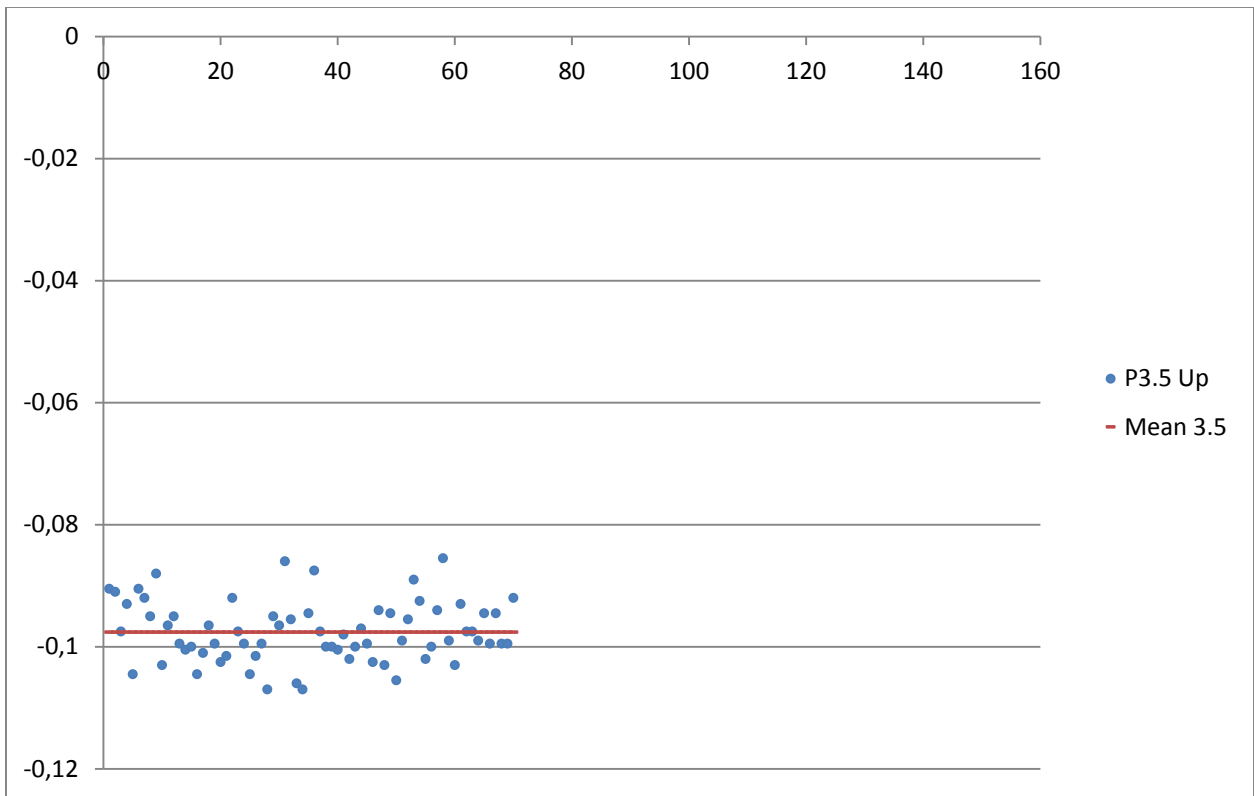

Figure 53. Data at 3.5 bar graph.

Appendix D Calculations

The new tolerances are calculated with transducer accuracy included. First the Pressure regulator is calculated because it is the valve which requires the highest tolerances. Followed up is the Single Port Relay Valve which is separated into two parts. First when the pressure is increasing and then when the pressure is decreasing.

Tolerances Pressure Regulator

Pressure regulator has a tolerance of 2%

$$\frac{0.05 + 0.05}{5} = 0.02 = 2\%$$

Together with the accuracy $X = 1\% = 0.01$ of the transducer this will not be enough to handle the task. It is all explained below.

- $P1$ is the lowest outlet pressure allowed, $5 - 0.05 = 4.95 \text{ bar}$ in this example
- $P2$ is the highest outlet pressure allowed, $5 + 0.05 = 5.05 \text{ bar}$ in this example
- P is the pressure wanted, 5 bar in this example
- $T1$ is the lowest pressure allowed, showed and measured by the transducer
- $T2$ is the highest pressure allowed, showed and measured by the transducer
- $Y1$ is the pressure difference between P and $T1$,
- $Y2$ is the pressure difference between P and $T2$,
- $Z1$ is the pressure difference $P1$ and $T1$, $X(P - Y_1) = Z_1$
- $Z2$ is the pressure difference between $P2$ and $T2$, $X(P - Y_2) = Z_2$

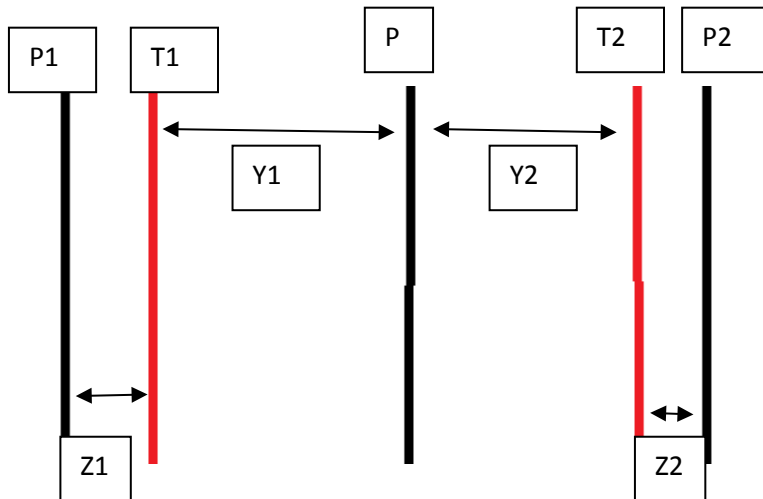

$$P + Y_2 + Z_2 = P_2 \Leftrightarrow P + Y_2 + X(Y_2 + P) = P_2 \Rightarrow Y_2 = \frac{5.05 - 5 - 0.01 * 5}{1.01} = 0 \text{ bar}$$

$$P - Y_1 - Z_1 = P_1 \Leftrightarrow P - Y_1 - X(P - Y_1) = P_1 \Rightarrow Y_1 = \frac{P_1 - P + X * P}{X - 1} = 0 \text{ bar}$$

Single port relay valve rising pressure

$$P + Y_2 + Z_2 = P_2 \Leftrightarrow P + Y_2 + X(Y_2 + P) = P_2 \Rightarrow Y_2 = \frac{3.55 - 3.5 - 0.01 * 3.5}{1.01} = 0.0149 \text{ bar}$$

$$T_2 = P + Y_2 = 3.5 + 0.0149 = 3.5149 \text{ bar}$$

$$P - Y_1 - Z_1 = P_1 \Leftrightarrow P - Y_1 - X(P - Y_1) = P_1 \Rightarrow Y_1 = \frac{3.35 - 3.5 + 0.01 * 3.5}{0.01 - 1} = 0.1161 \text{ bar}$$

$$T_1 = P - Y_1 = 3.5 - 0.1161 = 3.3838 \text{ bar}$$

Single port relay valve decreasing pressure

$$P + Y_2 + Z_2 = P_2 \Leftrightarrow P + Y_2 + X(Y_2 + P) = P_2 \Rightarrow Y_2 = \frac{3 - 2.9 - 0.01 * 3}{1 + 1.01} = 0.0693 \text{ bar}$$

$$T_2 = P + Y_2 = 3 + 0.0693 = 3.0693 \text{ bar}$$

$$P - Y_1 - Z_1 = P_1 \Leftrightarrow P - Y_1 - X(P - Y_1) = P_1 \Rightarrow Y_1 = \frac{2.9 - 3 + 0.01 * 3}{0.01 - 1} = 0.0707 \text{ bar}$$

$$T_1 = P - Y_1 = 3 - 0.0656 = 2.9293 \text{ bar}$$