

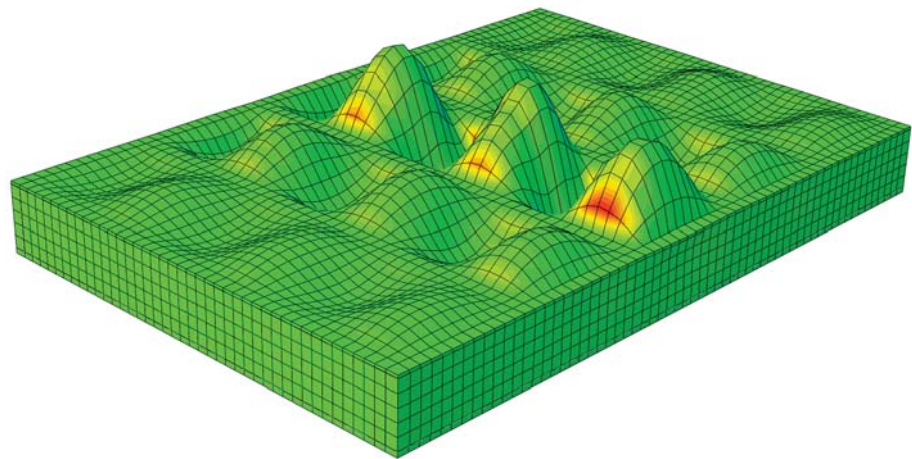

**LUND**  
UNIVERSITY



# INVESTIGATION OF IMPACT SOUND BEHAVIOUR IN LIGHTWEIGHT FLOOR CONSTRUCTIONS

**A Market Survey and Finite Element Analysis**

FANNY SANDBERG

---

Engineering  
Acoustics

*Master's Dissertation*

---



DEPARTMENT OF CONSTRUCTION SCIENCES  
DIVISION OF ENGINEERING ACOUSTICS

ISRN LUTVDG/TVBA--16/5049--SE (1-77) | ISSN 0281-8477

MASTER'S DISSERTATION

# INVESTIGATION OF IMPACT SOUND BEHAVIOUR IN LIGHTWEIGHT FLOOR CONSTRUCTIONS

A Market Survey and Finite Element Analysis

FANNY SANDBERG

Supervisors: **DELPHINE BARD**, Assoc. Prof., Div. of Engineering Acoustics, LTH, Lund  
together with **EMMA ARVIDSSON**, MSc, and **ERLING NILSSON**, PhD, Saint-Gobain, Ecophon AB.

Examiner: Professor **ERIK SERRANO**, Div. of Structural Mechanics, LTH, Lund.

Copyright © 2016 by Division of Engineering Acoustics,  
Faculty of Engineering LTH, Lund University, Sweden.

Printed by Media-Tryck LU, Lund, Sweden, June 2016 (PI).

**For information, address:**

Division of Engineering Acoustics,  
Faculty of Engineering LTH, Lund University, Box 118, SE-221 00 Lund, Sweden.

Homepage: [www.akustik.lth.se](http://www.akustik.lth.se)



---

## ABSTRACT

---

In the last years, the interest in high-rise timber framed building has gone up resulting in an increased demand for good solutions regarding sound insulation. Due to the worldwide growing interest in environmental issues, it has become of greater importance for companies to find ways to take care of their residue, instead of throwing it away. This can benefit both the environment, as less new material is used, and the economy, as less material goes to waste. Ecophon is presently developing a new type of lightweight aggregate (LWA) from glass wool residue that comes from their production of sound absorbing tiles. It will be investigated if these new LWA's can be used as ballast in intermediate floors.

The aim of this thesis is to find intermediate floor constructions where the new materials can be used. A market survey will provide the basis and suggest a few specific floor constructions where the LWA's could replace other insulation materials.

To further investigate the materials sound insulation properties in an actual floor, a FEM-calculation in Abaqus will be used. The FEM-modelling will be executed on a standard type floor to ease further comparison with other filling materials. The FEM-modelling will give the opportunity to compare the new materials with others that are commonly used in today's market. The results from the FEM-calculation will also be compared to measurements done by the consulting company Akustikverkstan.

Analyzing accelerations in the bottom plate for frequencies up to 125 Hz showed no significant improvement when adding LWA 1 into the floor. The accelerations decreased for some frequencies but then again got worse for others. To motivate an improvement, the accelerations would have to be lowered for all calculated frequencies. The most likely reason for the LWA's acoustic performance is its lack of stiffness which otherwise is the main reason to add mass. In this case, the mass is added without providing the necessary amount of stiffness.

With the measurements of the laboratory room at Akustikverkstan, it was possible to recalculate the accelerations in the bottom plate of the Abaqus model into sound pressure levels. This made comparison possible and one could see a correlation between the measurements and the calculations. Possible applications for the material should be investigated further as the manufacturing process is cheap and energy efficient in comparison to other recycling methods for mineral wool residue. This is of interest for Ecophon, not only from an environmental point of view but also from an economical perspective.



---

## SAMMANFATTNING

---

Efter en lång period där många bränder härjade i Sveriges storstäder förbjöds höga trähus. Denna lag upphörde att gälla i mitten på 90-talet och sedan dess har intresset för höga trähus ökat. Detta har resulterat i att behovet av bra ljudisoleringslösningar har blivit större.

På grund av det växande intresset för miljöfrågor har det blivit viktigare för företag att hitta nya lösningar för att ta hand om sitt avfall. Den typen av resonemang gynnar både miljön då mindre jungfruligt material behövs och ekonomin eftersom mindre material går till spillo. Ecophon håller för närvarande på att utveckla en ny typ av lättballast från den glasull som blir över vid deras övriga produktion. I denna uppsats kommer det att undersökas om denna lättballast kan användas som ballast i mellanbjälklag.

Syftet med uppsatsen är att hitta mellanbjälklagskonstruktioner där den nya ballasten kan användas. En marknadsundersökning ger grunden för att kunna föreslå vilka material som används i dag samt vilka material som skulle kunna bytas ut mot den nya ballasten.

För att vidare undersöka de nya materialens prestanda i ett faktiskt golv har FEM-beräkningar utförts i Abaqus. FEM-modelleringen utförs på ett standardgolv för att underlätta vidare jämförelser med andra isoleringsmaterial. Resultaten från FEM-beräkningen kommer också jämföras mot mätningar som utförts av konsultbolaget Akustikverkstan.

Vid analys av accelerationer i bottenplattan för frekvenser upp till 125 Hz kunde man inte se någon signifikant förbättring då den nya ballasten lades in i golvet. Accelerationerna minskade vid vissa frekvenser men blev också högre vid andra. För att motivera en förbättring bör accelerationerna bli lägre vid alla frekvenser i det undersökta spektret. Den troligaste anledningen till den nya ballastens akustiska prestanda är dess brist på styvhet, vilket anars är huvudanledningen till att man adderar massa till en lätt konstruktion. I detta fall är massa adderad utan att få den nödvändiga styvheten. Med måtten på labbet i Akustikverkstan blev det möjligt att räkna om accelerationerna från Abaqus till ljudtrycksnivåer. Detta gjorde jämförelse möjlig och man kunde se en korrelation mellan akustikverkstans mätningar och FEM-resultaten.

För framtida utveckling bör andra möjliga applikationer för materialet undersökas. Att hitta en användning för detta material bör ligga i Ecophons intresse eftersom tillverkningsprocessen är energieffektiv i jämförelse med andra återvinningsmetoder för glasull. Detta kan ge en vinst, inte bara ur miljösynpunkt utan också ur ekonomisk synvinkel.





---

## ACKNOWLEDGEMENTS

---

This master thesis has been carried out at the Division of Engineering Acoustics at the Institute of Technology at Lunds University, Sweden.

First of all I would like to express my deepest gratitude to my supervisors Delphine Bard, Emma Arvidsson and Erling Nilsson. Your calm, and always positive ways have been a great support. I would also like to thank PhD Juan Negreira for helping me, even though it has been stressful at times.

I wish to send a special thank you to my dear friend Anna for proofreading, and always being there for me.

Most of all I want to send all my love to my fantastic family who is always there for me, and to Johan who stays with me, for better and for worse.

Fanny Sandberg

Lund, June 2016



---

## CONTENTS

---

<b>I</b>	<b>THEORY</b>	9
1	INTRODUCTION	11
1.1	The Company	11
1.2	Thesis Background	11
1.3	Purpose	12
1.4	Scope and Limitations	12
1.5	Dissertation of contents	13
1.6	method	13
2	IMPORTANT CONCEPTS	15
2.1	Sound and Noise	15
2.2	Sound pressure Level (SPL)	16
2.3	Frequency and Amplitude	17
2.4	Frequency Band	17
2.5	Velocity of Sound	18
2.6	Properties of a Single Wall and a Double Wall	19
2.7	Sound Classification	20
2.8	Defining sound insulation performance	21
2.9	Flanking Transmission	21
2.10	Absorption	22
2.11	Impact Noise	23
2.12	Tapping Machine	25
2.13	Porous material	25
2.14	Lightweight Aggregate	26
2.15	Standards and Building regulations	26
3	THE NEW MATERIALS	29
3.1	Description of LWA 1	29
3.2	Description of LWA 2	30
<b>II</b>	<b>MARKET SURVEY</b>	33
4	INVESTIGATION OF INTERMEDIATE FLOORS	35
4.1	Wood as Load bearing Structure	35
4.1.1	CLT	35
4.1.2	Box Elements	37
4.1.3	Glulam Beams	38
4.1.4	Volume Elements	39
4.2	Suggestions of Replicable Materials	41

4.2.1	CLT . . . . .	42
4.2.2	Box Elements . . . . .	43
4.2.3	Glulam . . . . .	44
4.2.4	Cassette elements . . . . .	45
5	ECONOMY . . . . .	47
6	ENVIRONMENTAL ASPECTS . . . . .	49
<b>III</b>	<b>CALCULATIONS . . . . .</b>	<b>51</b>
7	FINITE ELEMENT MODELLING . . . . .	53
7.1	Introduction to the Finite Element Method . . . . .	53
7.2	Design . . . . .	53
7.3	Aim for Calculations . . . . .	55
7.4	Modelling a floor in Abaqus . . . . .	56
7.4.1	Defining materials in Abaqus . . . . .	56
7.4.2	Workflow for Abaqus . . . . .	57
7.4.3	Validation of the Model . . . . .	61
7.4.4	Alternation of Material Parameters . . . . .	64
7.5	Comparing results . . . . .	64
7.5.1	Comparing Abaqus Simulation Results . . . . .	65
7.5.2	Comparing Abaqus Simulation Results With Measurements . . . . .	65
7.6	Results . . . . .	68
7.7	Conclusions from Abaqus Simulations . . . . .	72
<b>IV</b>	<b>CONCLUSION . . . . .</b>	<b>73</b>
8	DISCUSSION . . . . .	75
8.1	Market Survey . . . . .	75
8.2	Calculations . . . . .	77
8.3	Proposal of Future Work . . . . .	77
<b>V</b>	<b>APPENDIX . . . . .</b>	<b>89</b>
A	APPENDIX A . . . . .	91

Part I  
THEORY



---

## INTRODUCTION

---

### 1.1 THE COMPANY

Saint-Gobain Ecophon AB is an international company, which develops and produces acoustic products and systems to improve the sound environment. Ecophon, that is a part of the Saint-Gobain group, has business units in 14 countries and delegations in another 30 countries worldwide.

### 1.2 THESIS BACKGROUND

For a long time, there was a Swedish law stating that you could not build timber framed buildings more than two storeys high. This law was founded in the 19th century when fires were common ravaged the cities, causing a lot of damage. The law was lifted in the mid-nineties and since then, interest in high-rise timber framed building has gone up. As interest increased, the demand for good solutions regarding sound insulation have been necessary to meet the Swedish laws and restrictions for noise.

The low frequency impact sound is generally governed by the mass and stiffness of the structure [1]. This gives an acoustical advantage to concrete structures over timber ones. Due to the worldwide growing interest in environmental issues, it has become of greater importance for companies to find ways to take care of their residue, instead of throwing it away. This can benefit both the environment, as less new material is used, and the economy, as less material goes to waste. Ecophon is presently developing a new type of lightweight aggregate (LWA) from glass wool residue that comes from their production of sound absorbing tiles. This new material is produced in both smaller and larger granules that can be used for different types of insulation. As these products are under development they still have no names but will in this thesis be called LWA 1 and LWA 2 (see figure 1.1).



Figure 1.1.: to the left: LWA 1 and to the right: LWA 2 [2]

### 1.3 PURPOSE

The aim of this thesis is to find intermediate floor constructions where the new materials can be used. A market survey will provide the basis and suggest a few specific floor constructions where the LWA's could replace other insulation materials. The main focus of the market survey is Swedish building techniques but it will also shed some light on other construction-examples from Europe.

To further investigate the materials sound insulation properties in an actual floor, a FEM-calculation in Abaqus will be used. The FEM-modelling will be executed on a standard type floor to ease further comparison with other filling materials. The FEM-modelling will give the opportunity to compare the new materials with others that are commonly used in today's market.

### 1.4 SCOPE AND LIMITATIONS

This thesis is in first-hand an evaluation of the new materials and their technical performance when used in intermediate floor constructions. As it is the insulating performance of the material that is of importance, flanking transmission from the potential floor-types will not be further investigated.

Due to the limited timeline, the insulating properties will only be investigated for a standard type floor, and not for all the floor types investigated in the market survey.



Although both impact and airborne sound is of interest when investigating insulation properties in floors, only impact sound (at low frequencies up to about 100 Hz) will be investigated.

To evaluate the materials relevance on the market, not only technical but also economic and environmental parameters are of interest, and will be investigated to fully analyze if there are advantages in producing LWA from glass wool residue. Economic and environmental aspects are however not the main aim of this thesis.

## 1.5 DISSERTATION OF CONTENTS

1. The purpose and background of the thesis is presented. Also, scope and limitations are discussed
2. Acoustical terms that are commonly used in building acoustics are closer explained
3. The new materials are explained in further detail and necessary material parameters are presented
4. The market survey is carried out and possible floor constructions are presented
5. An economical investigation of the costs of the materials that the new LWA's could replace
6. A discussion of the new materials environmental standard and whether they have advantage to other acoustical materials
7. Calculations in Abaqus of a standard wooden floor
8. A discussion of the thesis is carried out resulting in conclusions about the new materials and proposal of future work

## 1.6 METHOD

This thesis will be divided into three parts where different methods are applied. First, a literature study will be carried out, where the background to the problem will be investigated. Definitions of important concepts, such as impact sound, will be explained and the new LWA's will be described. Secondly, it will be evaluated if the LWA's could be used as impact sound insulation in intermediate floors. It will be investigated how floors can be constructed in multistory buildings today, together with an economical and environmental analysis. This part of the thesis will be based on interviews with building companies, acousticians on universities and employees at Ecophon. Finally, the characteristics of the LWA's will be investigated and compared to other types of sound insulation materials. This will be done by FEM-calculations in Abaqus.



---

## IMPORTANT CONCEPTS

---

To get a deeper understanding of the subject of acoustics, some important words and expressions are presented and described.

### 2.1 SOUND AND NOISE

Sound is defined as an oscillation in a medium or a material, most commonly propagated through air, resulting in a pressure variation [3]. The outer ear captures the vibrations in the air and leads it into the inner ear where it is amplified (see figure 2.1). The oscillations are transformed into nerve impulses that are recognized by the brain and result in sound.



Figure 2.1.: The ear[4]

Sound and noise are physically the same, however noise is defined as unwanted sound. What is unwanted sound is in many ways a subjective matter and up to the receiver to decide.

To help define unwanted noise, WHO [5] has made some measurements that can be used as guidelines. For example, the background noise should be at least 15 dB lower than speech to be able to get full speech intelligibility. Normal speech is around 60 dB, which means that a sound level of 75 dB can be disturbing and affect speech intelligibility. Speech intelligibility is a measure of how comprehensible speech is and can be affected by speech clarity as well as precision.

2.2 SOUND PRESSURE LEVEL (SPL)

Because the ear is sensitive to pressure variations in the air it is appropriate to describe sound by using the term sound pressure or acoustic pressure which has a linear scale with the unit Pascal [3]. However, since the human ear can perceive sound pressures at both very low and very high levels this makes it inconvenient to use a linear scale. Therefore, another measurement known as the sound pressure level (SPL), or sound level, is used. This is a logarithmic measurement that gives the ratio to the standard reference level. The standard reference level is set at the sound pressure 20  $\mu\text{Pa}$  and the frequency 1000 Hz, which a healthy individual can barely hear. This is also known as the threshold for human hearing, which using the decibel scale corresponds to 0 dB. The correspondence between sound pressure level and sound pressure is further explained in figure 2.2. Decreasing the SPL by 3 dB is equivalent to halving the sound pressure.

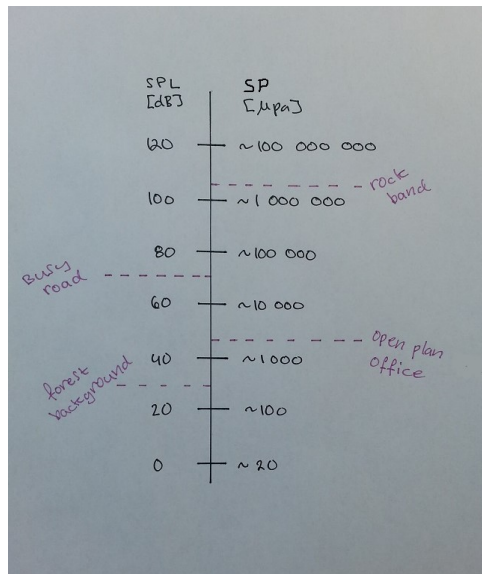

Figure 2.2.: Correspondence between sound pressure level (SPL) and sound pressure (SP)

## 2.3 FREQUENCY AND AMPLITUDE

Whether a tone is perceived as a high pitch or a low pitch depends on how fast the pressure change is [3]. The speed of the pressure change is measured in the number of periods per second and is called frequency. If the tone is high pitched the pressure change is fast, (a short wavelength) resulting in a high frequency. Similarly, for the low pitch tone the pressure change is slower, resulting in a lower frequency (figure 2.3). The human ear can hear frequencies between 20 Hz 20 000 Hz. On the other hand, whether a tone is perceived as strong or weak depends on the amplitude of the signal (figure 2.3).

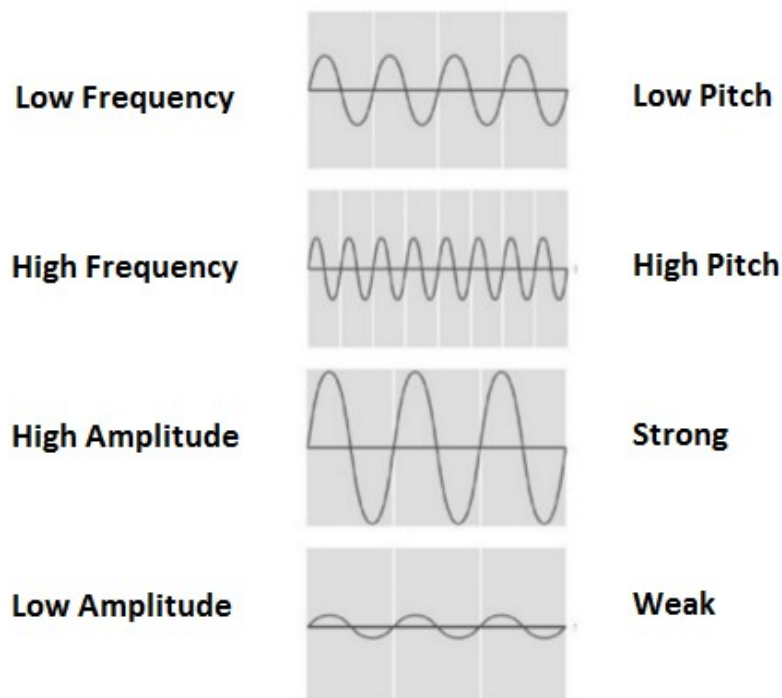

Figure 2.3.: Frequencies and amplitudes contra the perception of sound. Inspiration from [6]

## 2.4 FREQUENCY BAND

Different types of sound insulation is effective for different frequencies [3]. As a sound consists of a various amount of frequencies, an analysis of the frequency spectrum in a sound environment can give the tools to provide the right sound insulation. When investigating what frequencies a sound contains, it can be divided in frequency bands. An "octave" means

doubling of frequency and a "third" stands for a third of the octave. The octave and third are easiest to describe with the piano, where one can hear the difference in pitch (the octave is marked in figure 2.4).

For acoustics, the octave frequency band is most commonly used for traffic noise analysis while the third frequency bands are more often used in room acoustics. The third frequency bands are basically used for a more detailed analysis. The middle frequency is used to name the octave and third bands and having that, the bandwidth can be calculated. The bandwidth is the difference between the highest and lowest frequency in the band.

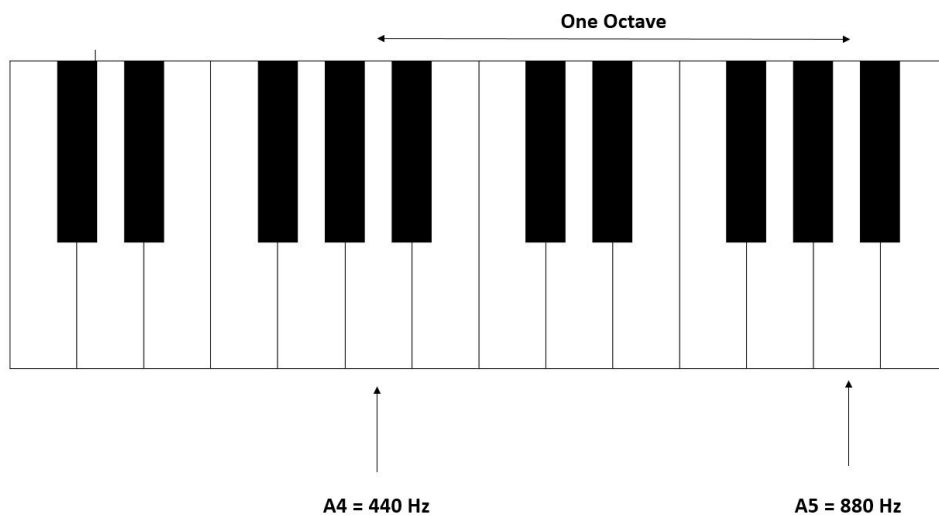

Figure 2.4.: Frequencies can be divided in bands. This piano shows an octave.

## 2.5 VELOCITY OF SOUND

It takes time for the sound to travel and the speed at which it travels depends on the material it is propagating in [3]. The density of the material plays an important role since materials with higher densities propagate sound faster.

Material	Long Velocity (m/s)	Shear Velocity (m/s)
Air	340	0
Steel	5900	3200

Table 2.1.: Velocity of sound in steel and air [3] [7].

As shown in table 2.1, a solid material, like steel, carries the sound forward much faster than air. Also, in a solid material the sound wave can be both long and shear. This is an important

factor to take under consideration when building a house. For example a steel beam running through an insulation material can create an audio bridge.

## 2.6 PROPERTIES OF A SINGLE WALL AND A DOUBLE WALL

A single wall is defined as a wall that consists of one layer, for example a concrete wall. When air borne sound hits a wall, bending waves will occur [3]. This type of wave gives the particles both long, shear and rotational movement. The insulating properties of the wall is basically dependent on the walls ability to resist the bending waves as this prevents the air borne sound to propagate. For lower frequencies, the walls spring stiffness will be the physical phenomenon that mainly affects the walls insulating ability. This is called the zero-mode-range. If the frequency increases slightly, mass and spring stiffness interacts which will result in resonances at some frequencies. The frequency range with the first resonance frequencies is called the few-mode-range and this is the behaviour that light weight constructions often shows. As the frequency increases, the resonances become more frequent. However, higher frequencies leads to faster pressure fluctuations which in turn makes it harder to move the wall. In conclusion, the resonances will not show in the curve and the sound pressure-frequency dependency will be linear in this frequency range. This frequency range is called the multi-mode-range. The single walls behaviour is described in figure 2.5.

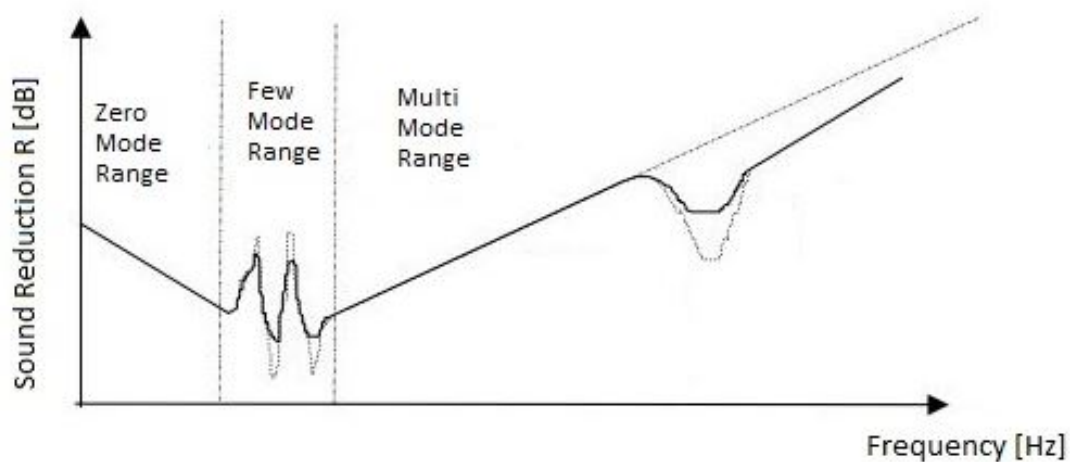

Figure 2.5.: Principle sketch of the sound reduction/frequency dependence for a single wall [3]. The few-mode range is typical for light weight constructions and the multi-mode range is typical for heavy constructions.

A double wall is defined as two plates that are separated with air, mineral wool or some other type of filling material. This is a technique that is used to be able to build lighter constructions without losing the sound insulating properties. At very low frequencies, the double wall will have the same behaviour as the single wall but as frequency increases the both walls will start to work as two separate masses, connected with a spring whose stiffness is decided from the air or filling material in the cavities. This system also has resonance frequencies where the mass and spring coexist which gives the wall a significantly lowered insulating ability here. This can however be improved with for example mineral wool that transforms the sound energy into heat. At even higher frequencies the double wall starts to behave as two separate single walls which gives double sound reduction. The double wall's behaviour is visually described in figure 2.6.

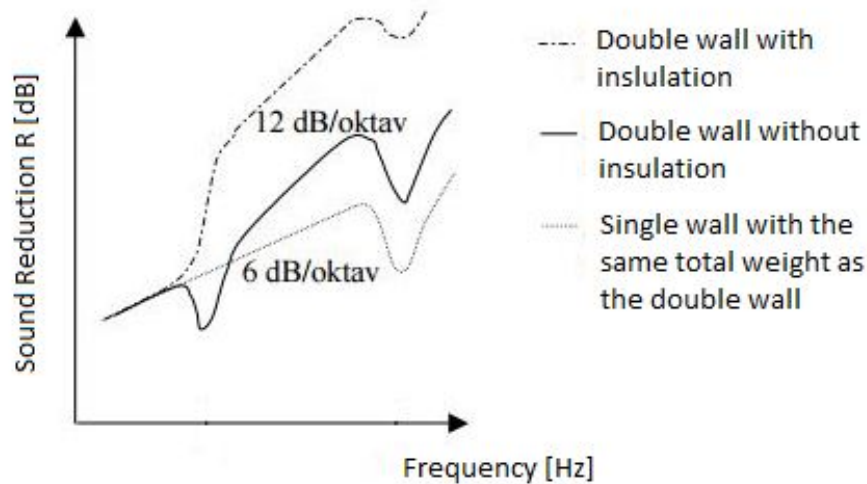

Figure 2.6.: The sound reduction for a double wall with and without insulation in the cavities. As a reference, a single wall with the same weight as the double wall is also plotted [3].

## 2.7 SOUND CLASSIFICATION

The Swedish building standard contains regulations for new constructions as well as for additions/changes of existing buildings [3]. The standard has four different sound classifications, A, B, BBR and D where sound classification A and B corresponds to very good acoustic conditions and BBR is the minimum standard for Swedish housing [8]. Class D is meant to be used if sound classification can't be achieved, for example during renovation. The sound classification limits are presented in table 2.2.



Sound Class	A	B	BBR	D
Airborne Sound Insulation ( $D'_{nT,w} + C_{50-3150}$ )	60	56	52	48
Impact Sound Insulation ( $L'_{nT,w} + C_{I,50-2500}$ )	48	52	56	60

Table 2.2.: Sound classifications described in dB [9]

## 2.8 DEFINING SOUND INSULATION PERFORMANCE

In Swedish housing there are regulations saying a certain amount of soundproofing has to be maintained to diminish noise such as those from neighbors or roads [3]. The sound insulation can be measured by using weighted values [8]. The weighted values summarize the performance of the building element (for example a floor) in one single value. For airborne sound, the weighted value is expressed as a sound reduction index (which means that a high value indicates good sound insulation). For impact sound, the sound insulation is described as a weighted value indicating the impact sound level (resulting in a lower value indicating good impact sound insulation).

## 2.9 FLANKING TRANSMISSION

The isolating ability of a partition wall is not only dependent on its own characteristics. Sound can also transmit via the flanking walls (figure 2.7). This type of sound transmission is called flanking transmission and to minimize it, well executed junctions are crucial. The flanking transmission is important to take into account to get the best sound reduction from the partition wall.

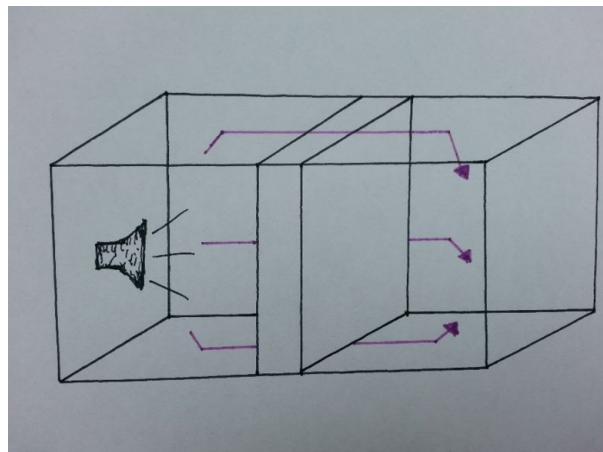

Figure 2.7.: Flanking transmission. Inspired by [3]

## 2.10 ABSORPTION

When a sound wave hits an object or material one part of the wave reflects and one part absorbs [3]. This can be described with equation 2.1 where  $\Pi_i$  is the incoming sound effect,  $\Pi_r$  is the reflecting sound effect and  $\Pi_a$  is the absorbed sound effect.

$$\Pi_i = \Pi_r + \Pi_a \quad (2.1)$$

One part of the absorbed sound wave energy converts to heat energy and the rest transmits through the material or object (see figure 2.8). A materials sound absorbing properties are defined by the absorption coefficient ( $\alpha$ ) which gives the share of the sound effect that absorbs (see equation 2.2). The absorption coefficient ranges from 0 (total reflection) to 1 (total absorption).

$$\alpha = \frac{\Pi_a}{\Pi_i} \quad (2.2)$$

The absorption area (A) gives a partial area, with  $\alpha = 1$ , that corresponds to the same absorption that the actual absorbing surface (S) will give. In conclusion: A is a theoretical area while S is the actual area that can be measured in a room. The absorption area can be described with equation 2.3 and an example follows bellow to further describe the concept.

$$A = \alpha \cdot S \quad (2.3)$$

An absorbent, say a curtain, with  $\alpha = 0.5$  and  $S = 5 \text{ m}^2$  will have an absorption area of  $0.5 \cdot 5 = 2.5 \text{ m}^2$ . This means that  $2.5 \text{ m}^2$  of an absorbent with  $\alpha = 1$  (this corresponds to a  $2.5 \text{ m}^2$  open window) will give the same absorption that  $5 \text{ m}^2$  of the original absorbent (the curtain).

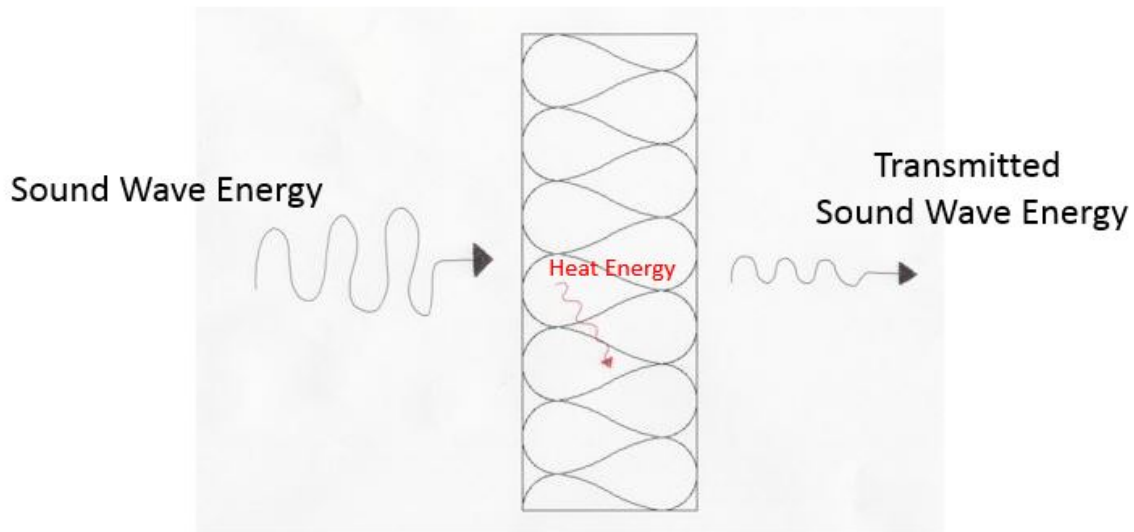

Figure 2.8.: Parts of the sound wave energy is converted into heat. The rest transmits through the material.

## 2.11 IMPACT NOISE

When parts of a building structure is excited, the vibrations are transferred as sound pressure to other parts of the structure, for example another room or apartment [3]. Usually, sound impact noise appears when walking on a floor. It can be very intense and therefore make the sound travel far (figure 2.9). The surface of the floor can be of interest when studying impact noise. For a barefoot walker, the floor surface is not as significant for the sound impact as it is for a person with shoes. The barefoot walker basically causes same frequencies when walking on a hard surface (for example tiles) as a soft (for example a rug), unlike the shoe wearing walker. This is important to take under consideration when designing and testing sound insulation systems.

The normalized impact noise  $L_n$  can be calculated under laboratory conditions with the equation bellow, where  $L_i$  is the sound pressure in the receiving room and  $A$  is the theoretical absorption area in the receiving room.

$$L_n = L_i + 10 \cdot \log\left(\frac{A}{10}\right) \quad (2.4)$$

In Swedish regulations, the Weighted Normalized Impact Noise ( $L'_{n,w}$ ) is used [10]. This number is estimated by fitting a reference curve to the measured values. The weighted impact noise is read at 500 Hz at the adjusted reference curve according to ISO 717-2. When characterizing sound impact noise, the Weighted Normalized Impact Sound Level is called  $L_{n,w}$

for a building element tested under laboratory circumstances and  $L'_{n,w}$  when measurements have taken place in an actual building (see figure 2.10). Impact sound pressure level measured in the field can also be calculated with the standard reverberation time ( $T_0$ ) and is called the Standardized Impact Sound Pressure Level ( $L'_{nT}$ ) [11]. ( $L'_{nT}$ ) can be calculated with equation 2.5.

$$L'_{nT} = L'_i + 10 \cdot \log\left(\frac{T}{T_0}\right) \quad (2.5)$$

where  $T_0$  for dwellings is 0.5 s and  $T$  is the time of the measurement.

When characterizing impact noise from walking on wooden and concrete floors with effective covering, the  $L_{n,w}$  has shown to be an adequate measurement [10]. Unfortunately, it is not good enough when dealing with peaks at single low frequencies in timber joist floors and bare concrete floors. To take these effects into account, a so called spectrum adaption term,  $C_I$  was introduced in the ISO-standard:

$$C_I = L_{n,sum} - 15 - L_{n,w} \quad (2.6)$$

$$C_I = L'_{n,sum} - 15 - L'_{n,w} \quad (2.7)$$

$$C_I = L'_{nT,sum} - 15 - L'_{nT,w} \quad (2.8)$$

As it is the low frequencies that are of greatest interest for these calculations,  $C_I$  may be carried out for a larger frequency range (including 50, 63 and 80 Hz). The term is then denoted as  $C_{I,50-2500}$  or  $C_{I,63-2500}$ .

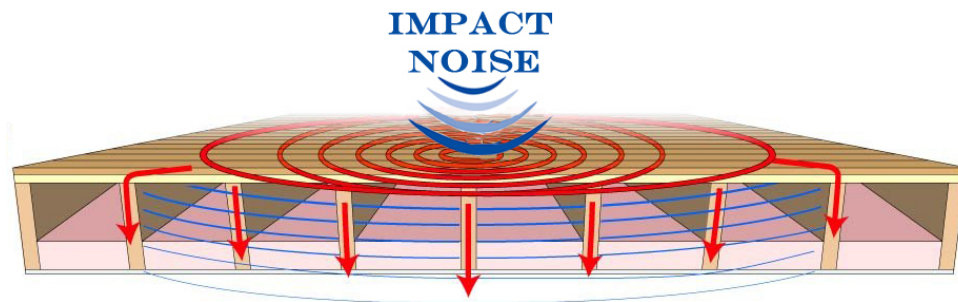

Figure 2.9.: Visualisation of impact noise [12].

## 2.12 TAPPING MACHINE

When measuring impact sound noise in a building, a tapping machine is used [13]. The tapping machine was originally developed to imitate the impact noise from high-heeled shoes and this can sometimes give misleading results as it is more common to be barefoot indoors, at least in Swedish dwellings. The barefoot walker causes impact sound in the lower frequency range while the high-heel gives frequencies in the higher frequency range. There are other instruments on the market developed for low frequency measurements, for example letting a rubber tire or ball fall to the floor. However, using the tapping machine is of international standard and most commonly used when investigating impact sound. The tapping machine should therefore in first hand be used. Sound transmission differs between the laboratory case and field situation [11]. In the laboratory case, the test specimen is often structurally separated from the primary construction, hence there are no vibrations travelling through walls and such (figure 2.10). Although flanking transmission has an impact, it's normally a greater problem when dealing with air-borne sound.

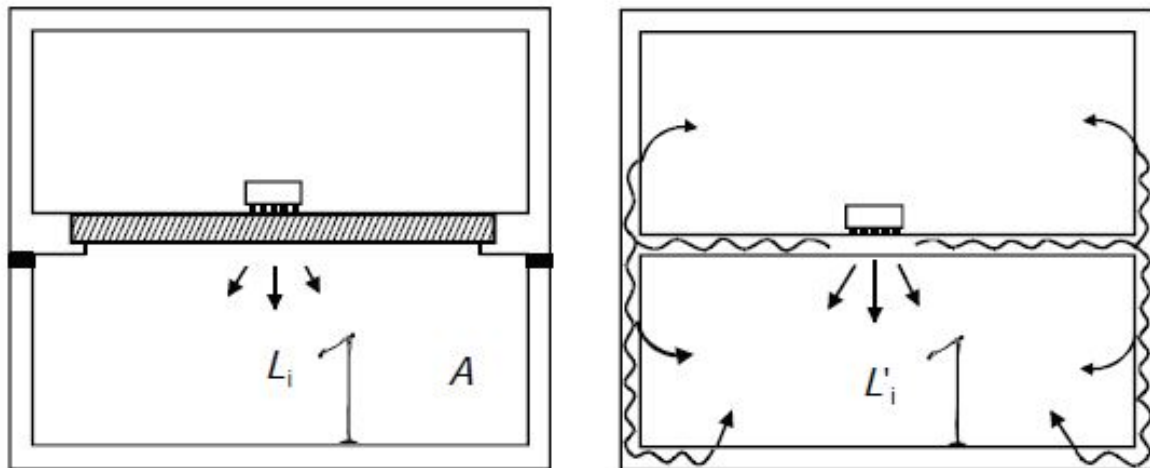

Figure 2.10.: Difference between a laboratory case (left) and a field case (right) [11].

## 2.13 POROUS MATERIAL

Building materials can be divided in two main categories: porous and compact [14]. In the following sub chapter the porous material is further described. A porous material consists partly of pores and partly of compact mass. Examples of porous materials can be concrete, wood or mineral wool. The porosity is of importance for a materials strength and also for a materials heat insulating properties. The insulating properties are the main reason for mineral wool to be a common material to use in most types of building constructions but it also have

sound insulating properties. This is due to the porosity of the material that forces an interaction between air and wool fibres [9]. The porous structure is forcing the sound pressure waves to travel a longer distance resulting in a damping effect from friction at the surface of the fibres.

#### 2.14 LIGHTWEIGHT AGGREGATE

A light weight aggregate can be defined as a coarse granular material. By definition the granular structure means collections of many macroscopic solid grains [15]. The difference between granule and grain is described in figure 2.11. In this thesis the grains are made from glass wool residue but in general the grains can be anything from rice to gravel.

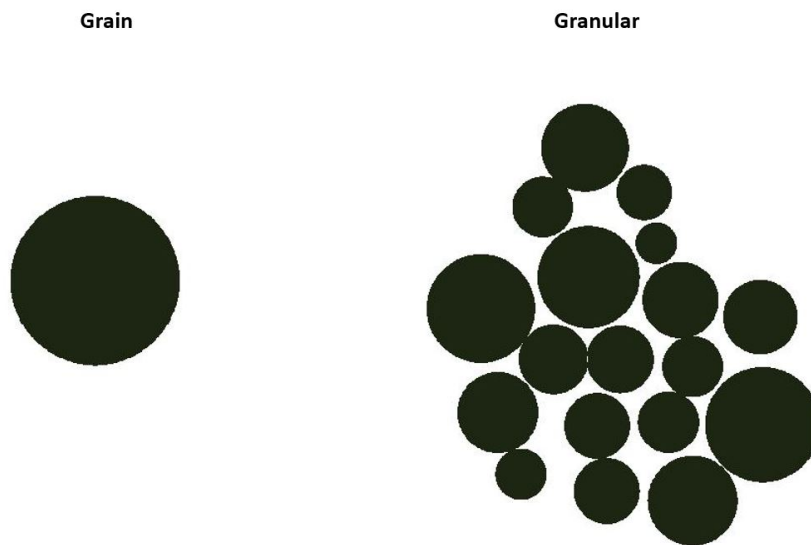

Figure 2.11.: The difference between "grain" and "granular".

#### 2.15 STANDARDS AND BUILDING REGULATIONS

In the last years, the interest for building light weight timber constructions have increased, which sets new demands on the current national building regulations [16]. When building a house, one must take into account the rules and restrictions that apply in the current country. The building restrictions exist to specify minimum requirements and as all regulations usually are based on international standards, they tend to bear many similarities. However, all countries usually have additional rules, which are a result of their traditions in building technique.

Swedish housing regulations are based on PBL (Plan- & Bygglagen) but BBR (Boverkets Byggregler) is the regulatory code that provides the practical application of the laws [17]. BBR therefore becomes the document used for more detailed information and advice. The chapter concerning noise insulation covers both airborne and impact noise. The general requirement says that buildings shall be constructed in a way that limits the occurrence and spread of noise. The maximum impact noise level recommended from BBR is 56 dB (sound classification BBR) and this level is valid for outside noise coming inside dwellings. More details and circumstance cases can be found in BBR.

In Sweden, the frequency range at which impact sound regulations must apply was extended down to 50 Hz in 1999 [16]. This was an attempt to include the problem of sound impact noise that arises in light weight buildings, but research work indicates that it is not enough in order to prevent acoustically poor constructions from entering the market. In the rest of Europe, the minimum frequency is set at 100 Hz although a reduction to 50 Hz is discussed. According to [16], one thing to have in mind when measuring impact sound is that the perceived sound insulation normally is worse than the objective measurements show. In the table below, minimum impact sound requirements are presented for some European countries:

Country	Impact sound [dB]
Austria	$L'_{nT,w} \leq 48$
Germany	$L'_{n,w} \leq 53$
Norway	$L'_{n,w} \leq 53$
Sweden	$L'_{n,w} \leq 56$
Switzerland	$L'_{n,w} + C_{I,50-2500} \leq 56$
	$L' \leq 56$
	$L' \leq 48$

Table 2.3.: Impact sound requirements in some European countries [16].

When viewing table 2.3 it must be considered that Swedish regulations demand measurements at a frequency range down to 50 Hz in contrast to the rest of Europe where there are only requirements down to 100 Hz. This means a floor that is approved according to for example Austrian standards can't be used in Sweden even though the standardized weighted impact noise level is lower in Austria than Sweden. This is due to the differences in frequency range requirements.





---

## THE NEW MATERIALS

---

Ecophon are developing two new granular materials with different grain sizes, giving the two aggregates different possible applications. The materials can be viewed in figure 3.1 - 3.2. This chapter is a short summary of the report on LWA 2 (the smaller granules) that Ecophon ordered from Saint-Gobain Research center earlier in 2015, interviews with Emma Arvidsson from Ecophon and measurements done in Ecophon's laboratory. The two granular materials are described, but as they are still in a developing process there are information gaps. Currently, the information on LWA 1 is incomplete in different areas, which is why all parameters cannot be accounted for both materials.

### 3.1 DESCRIPTION OF LWA 1

Originally, LWA 1 is a way to process the glass wool residue in order to send it to landfills where it can be used as construction material [18]. The residue is processed to grains, using process water from other production lines and cement. The proportions are roughly 10% cement, 15% process water and the rest is mineral wool residue. In this way, both glass wool residue and process water is taken care of and a fairly small amount of new material (cement) is put in the process. The final product is a granular material with irregular sized grains. Necessary material parameters were measured in Ecophon's laboratory and are presented in table 3.1.

Parameter	LWA 1	LWA 2
Density ( $\rho$ )	1400 $kg/m^3$	1000 $kg/m^3$
Yong's modulus ( $E$ )	-	$3 \cdot 10^6$
Poisson's ratio ( $\nu$ )	-	0
Loss Factor ( $\eta$ )	-	0.25
Porosity ( $\Phi$ )	40%	$\pm 1.2\%$
Resistivity ( $\sigma$ )	$300 \pm 97 Nsm^{-4}$	$6052 Nsm^{-4}$
Tortuosity ( $\alpha_\infty$ )	-	1.84
Viscous characteristic length ( $\Lambda$ )	-	184 $\mu m$
Thermal characteristic length ( $\Lambda'$ )	-	$1.4 \cdot 10^6 N/m$

Table 3.1.: Summary of mechanical parameters for LWA 1 and LWA 2

### 3.2 DESCRIPTION OF LWA 2

In contrary to LWA 1, LWA 2 are made from glass wool residue with a polymer binder instead of cement [18]. So far, these light weight aggregates have only been manufactured in small scale in laboratory environment. The grains have irregular size from 1-8 mm and a density around  $1000 kg/m^3$  which makes it lighter than many other ballast materials (for example gravel) but heavier than insulation materials such as mineral wool [19].

In the laboratory report carried out by [19], measured values are presented for both mechanical and acoustical parameters. The results can be found here in table 3.1.



Figure 3.1.: LWA 1 used at a landfill in Landskrona



Figure 3.2.: LWA 2 manufactured in laboratory



Part II

MARKET SURVEY



---

## INVESTIGATION OF INTERMEDIATE FLOORS

---

In this chapter a market survey of intermediate floors is presented. The goal is to find floor-types where the new LWA's can replace other sound insulation materials. The market survey is carried out by free interviews with a number of building companies and also by studying science reports. The chapter is divided in different types of load bearing structures.

### 4.1 WOOD AS LOAD BEARING STRUCTURE

Using wood as load bearing structure is very common when building single family houses. In Sweden over 80% of all single family houses are made from wood [20]. When it comes to multi-family building it is not as common and stands for only about 10% today. But because of new fire regulations and increasing interest in renewable materials, the interest in timber framed buildings have increased. The technique is also well suited for industrial building and prefabricating building elements can speed up the building process.

Building with wood can be done with regular sawn timber but the material can also be refined in many ways [21]. When layers of wood are glued, or in some other way joined to a solid product, it is called Solid Wood. Intermediate floors made from this types of techniques such as CLT, Glulam, Box Elements and Volume Elements are presented in the following sub chapters.

#### 4.1.1 CLT

CLT (or Cross Laminated Timber) is a building technique where timber lamellas are glued in multiple layers. Each lamella is perpendicular to its adjacent layer [21]. This technique results in an element being able to take load in two directions. CLT can be used as load bearing structure in multistory buildings or smaller houses. The CLT floor can be a plate of solid wood or a cassette structure which can be insulated in various ways. Concrete can be used in some extent, for example as leveler. This gives the floor more stiffness that in turn leads to less low frequency sound transmission [1].

Examples of what materials can be used are presented in the bullet list below, in order from floor-top to inner-ceiling. The first three examples in the list are built in Switzerland and Austria, and the last example is a Swedish type solution. Figure 4.1 and 4.2 are type sketches

and gives a general idea and visualization of what a CLT-floor can look like. A CLT slab could be replaced with Brettstapel. Brettstapel is another type of solid wood technique where no glue or nails are used, but instead the timber lamellas are joined with hard wood dowels [22].

- Floor covering, concrete leveler, impact sound insulation, cement panels, particle board, CLT [23]
- Floor covering, concrete leveler, impact sound insulation, layer of concrete on CLT or Brettstapel
- Floor covering, sound impact insulation, EPS Foam, concrete, PE-foil, CLT, mineral wool and gypsum that either can be installed directly on the CLT or alternatively as a suspended ceiling
- Floor covering, gypsum board, sound impact insulation, solid wood cassette structure filled with mineral wool, structure to hold up a suspended ceiling with mineral wool and gypsum [24]

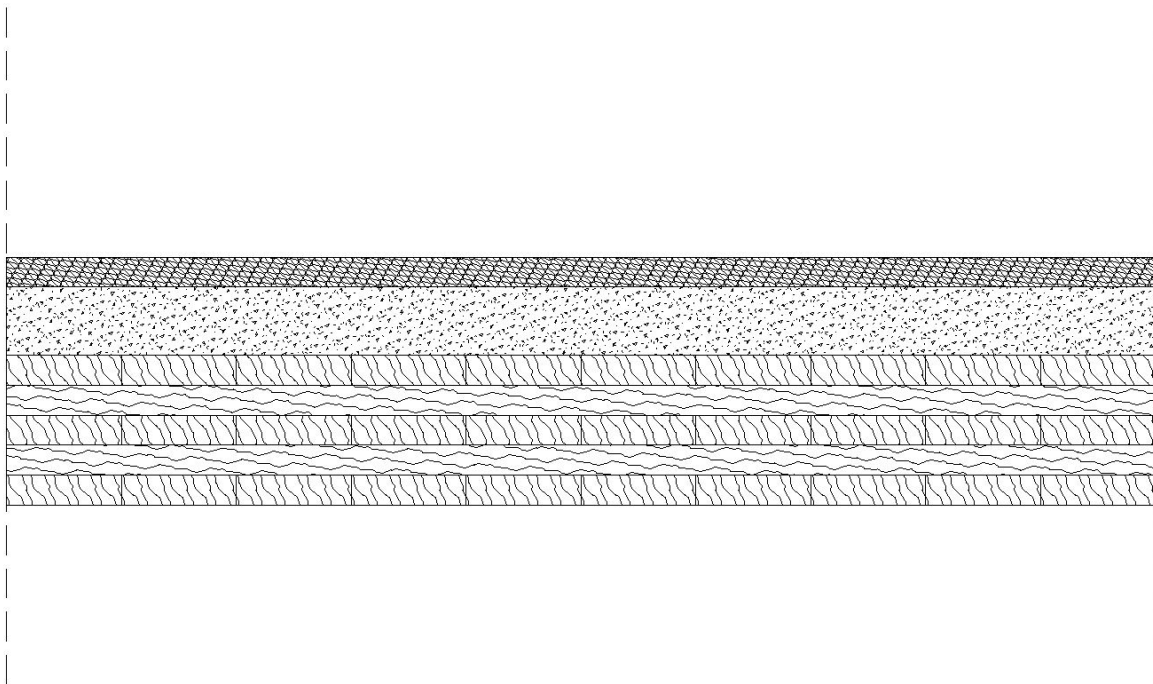

Figure 4.1.: General sketch of a CLT element [25]. The slab is covered with a layer of concrete with impact sound insulation layer on top.



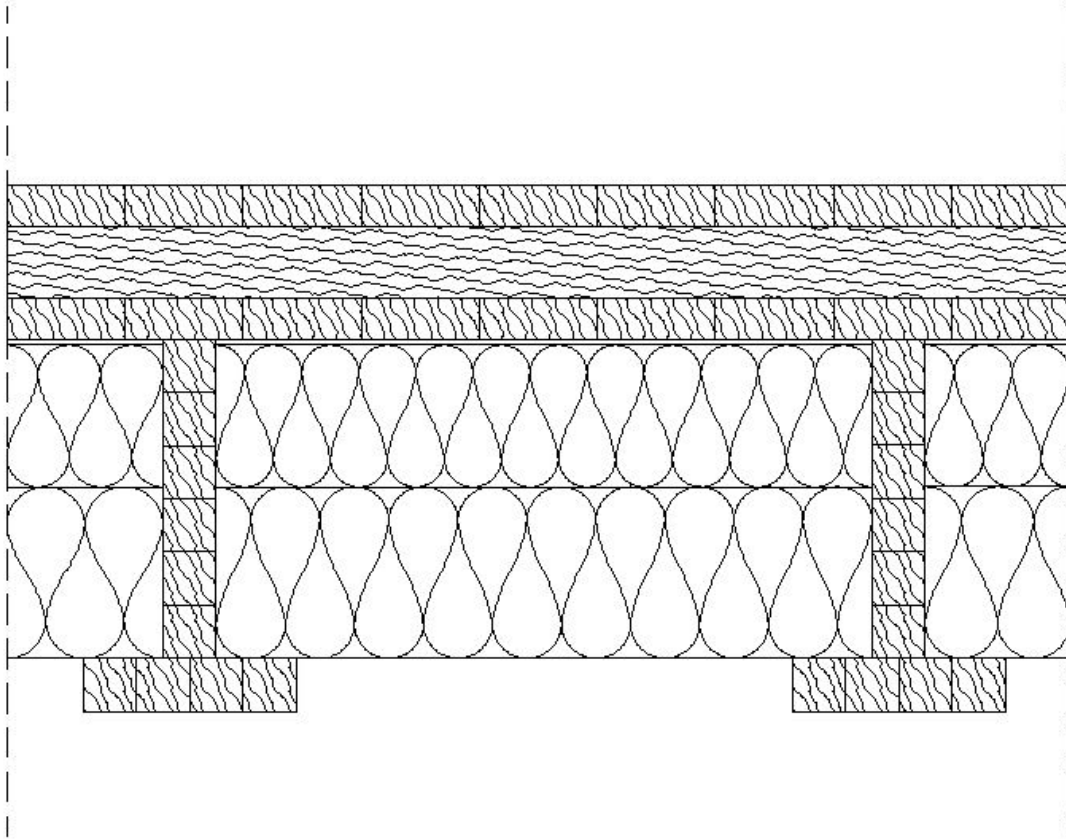

Figure 4.2.: 2D model of a cassette structure with inspiration from [24]

#### 4.1.2 Box Elements

Box systems are prefabricated elements where solid wood plates are joined with crossing bars to create a slab element [26]. Box elements are usually filled with insulating material and/or ballast to prevent sound to amplify (by reflection) inside the cavities. A ballast material gives more stiffness to the floor and reduce vibrations.

In the bullet list, the first example is a multifamily house in Switzerland and the second example a type construction from a Swiss company that is focused on industrial production of these types of floors. In figure 4.3 a type sketch of a box element floor slab is presented.

- Floor covering, concrete leveler, impact sound insulation, gypsum board, box element filled with ballast material [23]

- Floor covering, particle board, sound impact insulation, Layer of honeycomb fill, Box element filled with ballast material [26]

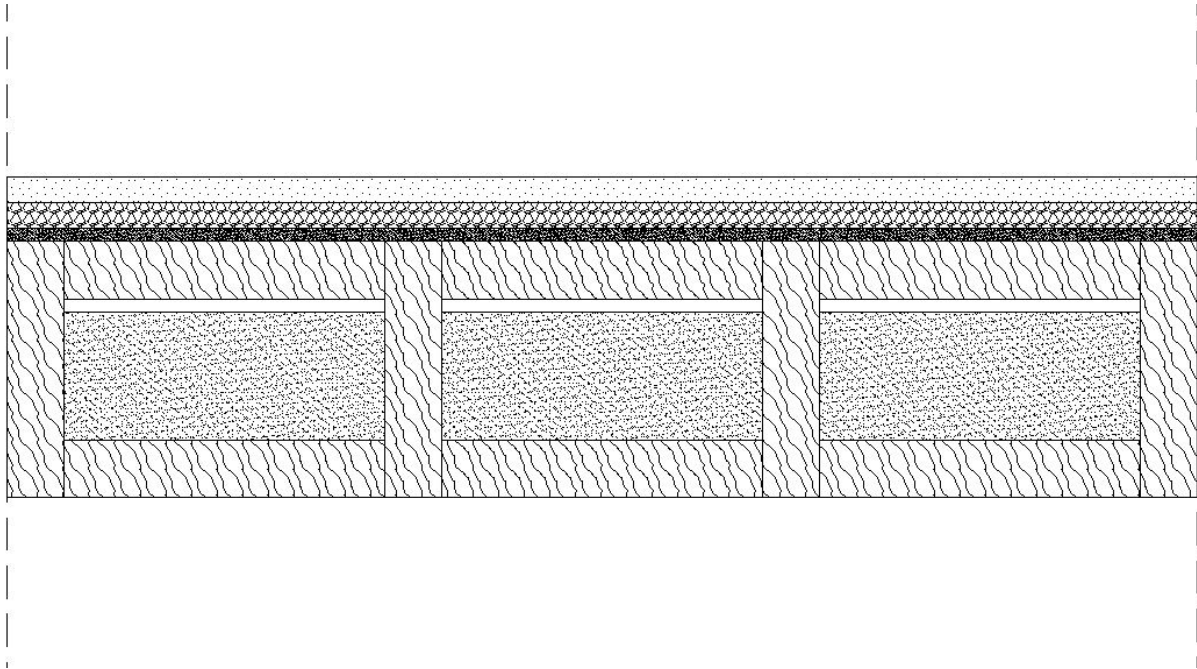

Figure 4.3.: Example of box element floor slab with inspiration from [27]. This box element is filled with ballast and there are three material layers (honeycomb fill, sound impact insulation and screed) on top.

#### 4.1.3 *Glulam Beams*

Glulam is a traditional technology with roots in the beginning of the 20th century [28]. Defects in the sawn wood such as knots, splits and sloping grain are randomly distributed throughout the beam allowing glulam to be designed to higher stresses than regular sawn wood of the same grade. It also can be manufactured in a wide variety of shapes and sizes and beams wider than normally can be manufactured.

When designing an intermediate floor with glulam one can have beams as primary structure, fill the cavities with insulation and put a floating floor with various layers of materials on top to provide good insulation as well as stability. The layers vary from building to building but examples are:

- Floor, cement leveling, impact sound insulation, cement board, particle board, beams of Glulam [23]

- Combine beams of glulam with a solid wood board in the bottom of the floor slab, creating something similar to a box element. The cavities are filled with mineral wool and on top of the bearing structure one can install a floating floor on an elastomer. The floating floor can consist of various layers of gypsum and particle boards
- Mineral Wool between beams and floating floor of particle board and gypsum installed on an elastomer to dampen out vibrations [29]

The first two examples in the bullet list above are from Switzerland and the last one is a Swedish construction. Figure 4.4 shows an example of what a glulam construction can look like.

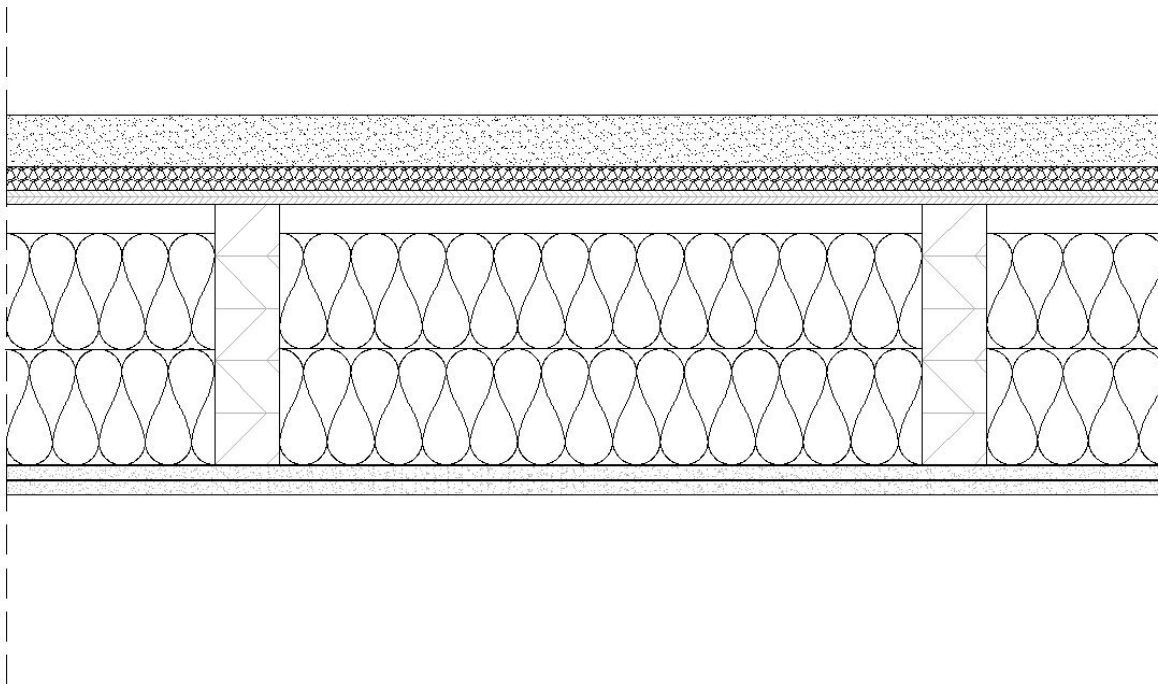

Figure 4.4.: Example of a glulam floor [30]. Stratigraphy from the top: sand, sound impact insulation board, particle board, glulam beams with mineral wool and two layers of gypsum.

#### 4.1.4 Volume Elements

In modern building industry, the interest of prefabricating building elements has increased in recent years [1]. Volume elements are a building technique where larger building elements are assembled at a factory. This makes the building process less sensitive to weather and gives a more secure quality control. The volume elements are assembled at the construction site.

Figure 4.5 and 4.6 shows a general sketch of a volume element building and a detailed design of a joint.

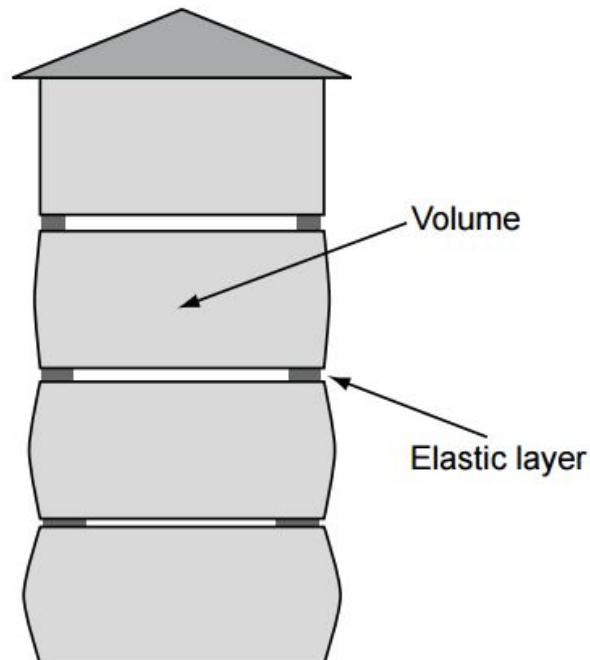

Figure 4.5.: The volume elements are prefabricated and assembled at the construction site. In order to prevent sound transmission between elements, an elastomer is put between the elements. [1]

Transfer of structure borne sound can be avoided by mechanically separating the volumes i.e. leaving space between ceiling and floor of adjacent volumes (see figure 4.6). With this type of design, impact sound can only be transferred through the flanks but this can be reduced by placing an elastomer at the edges of the volume. These layers must be dimensioned for the specific weight that is put on the elastomer, meaning that it is of importance to consider the increasing load far down the building. This phenomenon is described in figure 4.5. Volume elements are common in both Sweden and Norway where a construction could have the following layers [23]:

- { Upper element: particle board, glulam beams with mineral wool
- { Lower element: mineral wool between beams, gypsum board

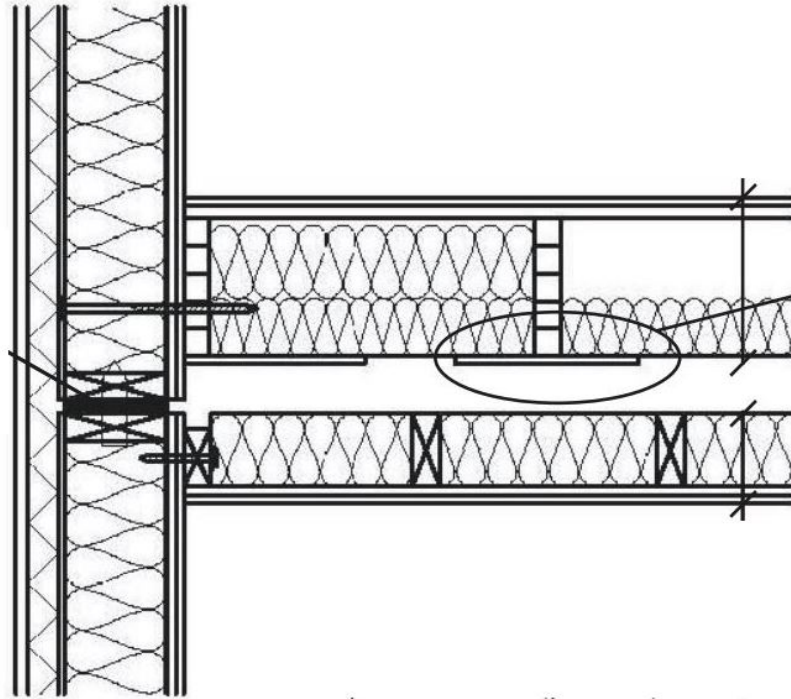
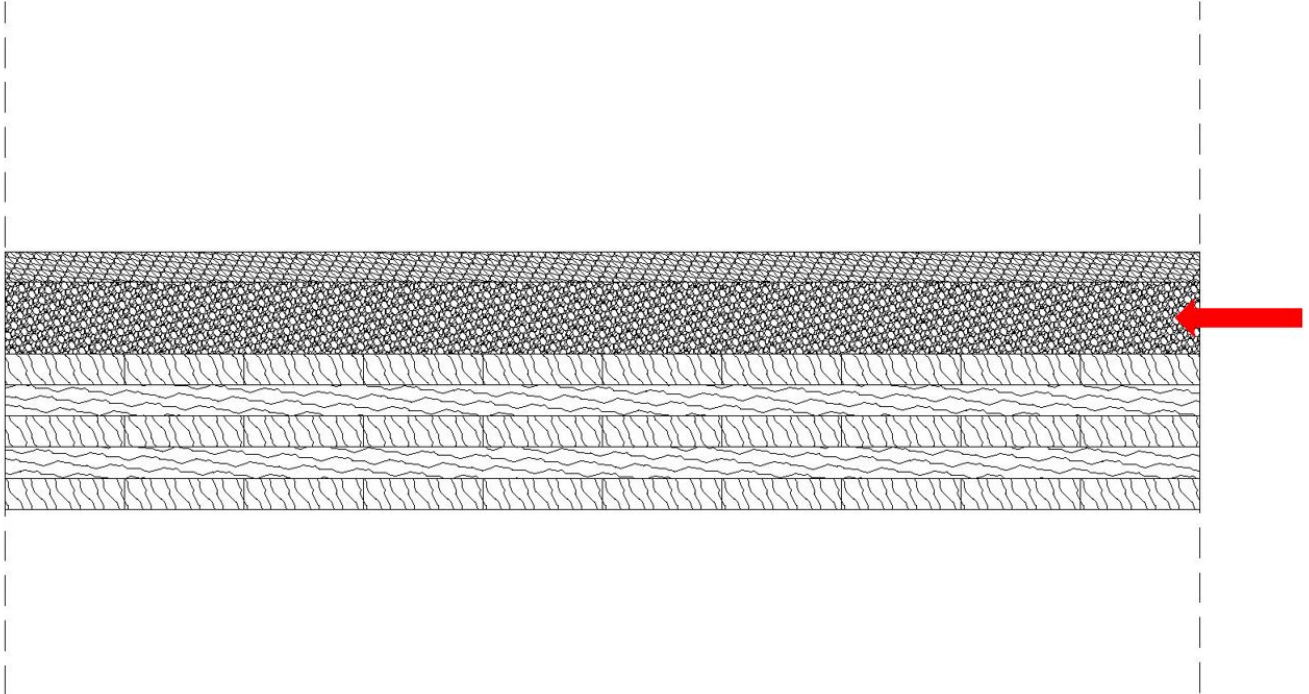

Figure 4.6.: Example of assembly between volume elements creating a floor slab [1].

#### 4.2 SUGGESTIONS OF REPLICABLE MATERIALS

The following sub chapter will present suggestions of materials that possibly could be replaced by Ecophon's new LWA's. The suggestions are based on the outcome of the market survey and are not tested on actual floors. The materials that are assumed to be replaced are mineral wool, concrete and sound impact boards. In a later state it is important to consider that these materials might also fulfill other building requirements. Concrete can for example be a part of the load bearing structure or work as a leveler to put flooring materials on, and mineral wool is a common heat insulator. Therefore, one cannot replace materials without considering all aspects of the construction first. In the figures in the following subchapter, some of the floor structures from chapter 4.1 have been altered to show where the LWA's could be placed.

4.2.1 CLT



In the case where the CLT is designed as a solid slab element, concrete leveler might be replaced with LWA 2 as these have smaller granule size and can create a relatively plane surface.

### 4.2.2 Box Elements

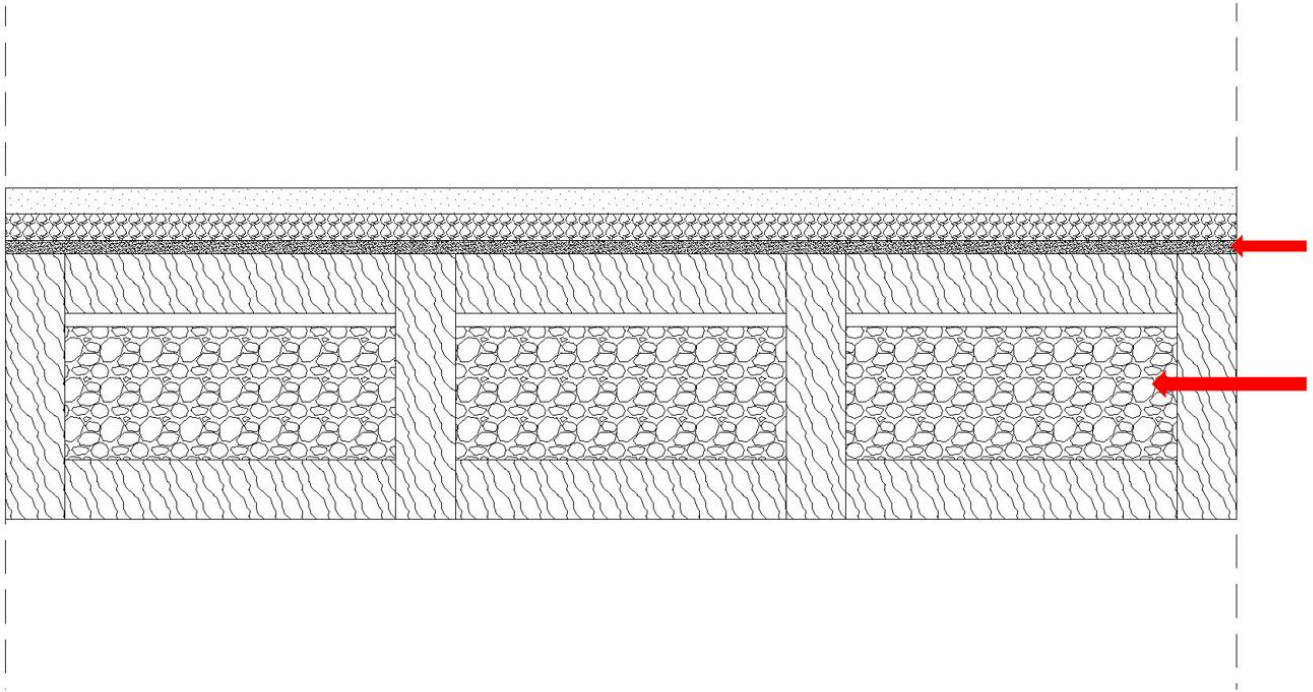

The cavities might be filled with LWA 1 instead of another ballast material. A concrete leveler or Honeycomb fill could be replaced with LWA 2.

4.2.3 *Glulam*

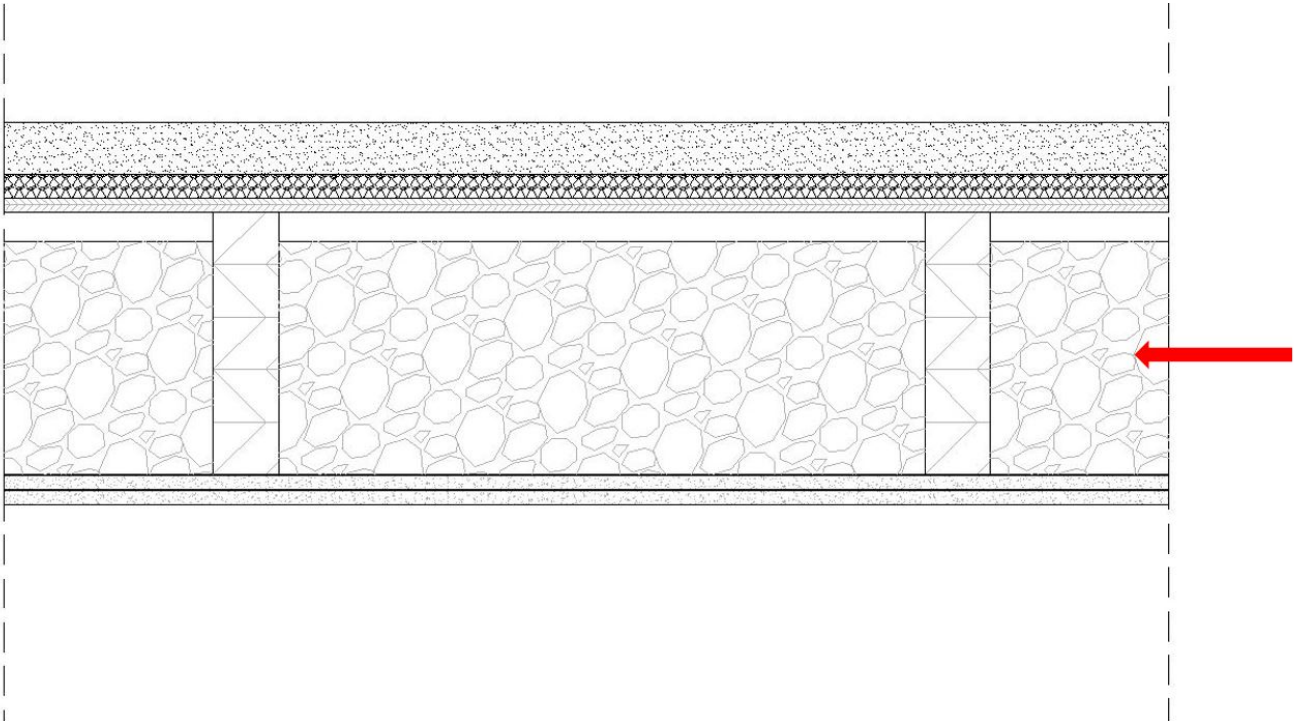

Parts or all mineral wool in cavities could be replaced with LWA 1.



#### 4.2.4 *Cassette elements*

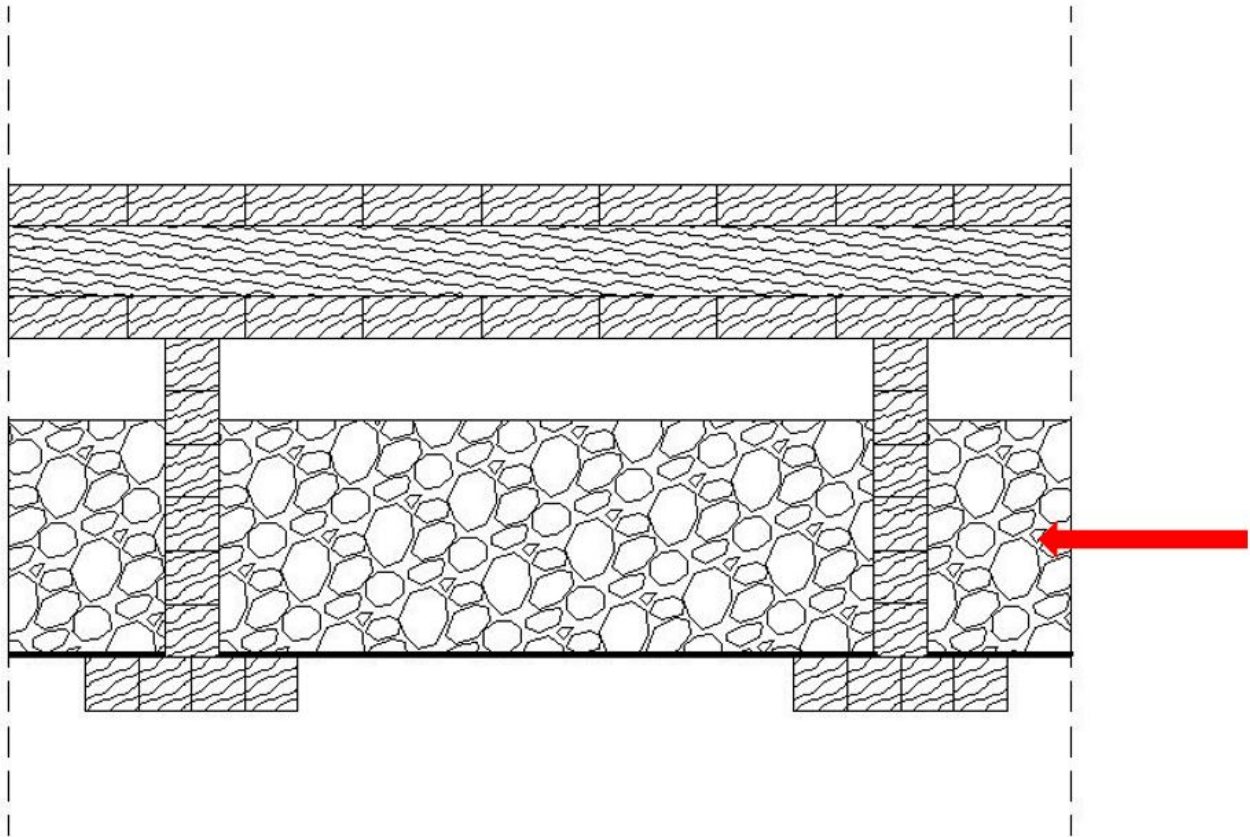

In the case with the cassette structures, a granule material seems difficult to use as filling inside the load bearing structure. Basically one can assume that the granules will need a well defined space to be able to stay in place. This is however possible to solve, for example by putting a particle board on the bottom of the cassette, creating a defined space for the granules.



---

 ECONOMY
 

---

This chapter is a short of the market survey where possible costs of traditional building materials commonly used in intermediate floors, are investigated. The goal is to be able to present a price span where the new LWA's needs to be in order to be competitive in the market.

The market survey revealed some materials that seems to be common as impact sound insulators:

- Mineral wool
- Ballast materials
- Concrete

Interviews with the builders' merchant Optimera [31] and the mineral wool manufacturer Isover [32] gave a general idea of how, and where companies buy their material. The conclusion is that larger building companies buy materials both from builder's merchants and directly from factories but usually they have special agreements giving them discounts for buying large amounts. The extent of these discounts are not a public matter, however it will be tested in a hypothetical example bellow. The discount in this example is not based on the above mentioned interviews, but was discussed with the supervisors at Ecophon.

Price examples of material costs are retrieved from Wikelks Byggbearkningar [33] and presented in the table below.

Material	Layer Thickness (mm)	Builders' merchant Price (SEK/m <sup>2</sup> )
Mineral Wool	95	44
Concrete	100	126
Gravel	100	96

Table 5.1.: Price levels for an approximate layer size of 100 mm for mineral wool, concrete and gravel [33]

As mentioned above, larger building companies usually have discounts when buying large amounts. As an experiment, a 50% discount was applied to see what price levels this resulted in (see table 5.2)

<b>Material</b>	<b>Layer Thickness (mm)</b>	<b>Price after discount (SEK/m<sup>2</sup>)</b>
Mineral Wool	95	22
Concrete Leveler	100	63
Gravel	100	48

Table 5.2.: Price levels for the materials mentioned in 5.2 after a 50 % discount

As the discount levels are not a public matter, this calculation can only be seen as an estimation but it gives an indication of the market with the conclusion being that depending on what type of material the new LWA's will replace, and if discounts are applied or not, the price level can range from ~20 SEK to ~ 120 SEK.

---

## ENVIRONMENTAL ASPECTS

---

There is a globally increasing interest for environmental issues leading the construction industry to take interest in sustainable building. The demands from EU increases when it comes to for example energy efficiency and material use [17]. The following chapter is based on an interview with Ecophons environmental specialist Anna Palminger [34].

The mineral wool waste that the LWA's consists of comes from Ecophons other production that mainly consists of acoustic inner ceilings. The ceilings have a surface treatment that makes it hard to put it back in production of mineral wool without contaminating the process. The LWA's are today under development but LWA 1 is in its present state used as a construction material at a landfill site in Landskrona. According to EU:s waste hierarchy the material is at the "recovery step" meaning it can be used instead of virgin materials but is still not fully recycled into a new product [35]. The goal is however to be able to "upgrade" the LWA's to recyclable materials, which in this case means that it becomes usable as an acoustical material. The steps of EU:s waste hierarchy can be seen in figure 6.1.



Figure 6.1.: EUs waste hierarchy [35]

Being able to recycle mineral wool residue can provide significantly lowered GWP's (Global Warming Potential) and of course also lowered waste production for Ecophons other mineral wool based products, as they are so called passive products (i.e. most environmental impact are in production stage and waste stage). This can be applied on all of Ecophons current EPD's, resulting in products with less GWP and less waste production.

Green building certification systems such as LEED and BREEAM can motivate building companies to choose alternative materials to improve their certification scores. It is however not for certain that one can raise their scores in such certification systems by replacing insulation materials in floor structures, this depends on how the score-system is designed. For example, insulation materials are excluded from the evaluation criterias in BREEAM [36]. In LEED, the rule applied is that one needs a certain amount (10 or 20 %) of recycled material in the entire building to require scores for using recycled materials [37]. The sound insulation in intermediate floors only stands for a small part of a building and therefor one will probably not be able to get scores in LEED just by using the new LWA's. To know for certain if the new LWA's could be advantageous when certifying a building, various certification systems must be more closely investigated. This is however not the aim for this thesis.

Part III

CALCULATIONS





---

## FINITE ELEMENT MODELLING

---

A floor will be modelled with the finite element method. A parametric study will be carried out where comparisons between traditional materials and the new LWA's are made.

### 7.1 INTRODUCTION TO THE FINITE ELEMENT METHOD

Solving engineering problems can often result in differential equations that is too complicated to be solved by classical analytical methods [38]. The finite element method (FEM) is a commonly used numerical method that consists of approximate general differential equations. The differential equations can describe physical problems (for example acoustic sound propagation) that holds over a region that can be one- two- or three-dimensional. But instead of trying to find an approximation that holds for the entire region, it is divided into smaller parts, so-called finite elements. The collection of finite elements in a region is called a mesh. The behavior for each element is approximated and a solution for the behavior of the entire region can then be obtained by assembling the elements into a global system.

When deriving a finite element problem, the system is transformed from having infinitely many unknowns (degrees of freedom) to having a finite number of unknowns. Problems that are solved with FEM generally have thousands of degrees of freedom and can only be calculated with a computer. The amount of degrees of freedom is governed by the number of elements in the region. Creating a finer mesh gives a more accurate result, but at the cost of increased time to solve the problem.

### 7.2 DESIGN

To make calculations, a simple floor model is chosen. This is partly to simplify the mesh and partly to have a basic standard at which one easily could add more to. It consists of glulam beams (56mmX270mm) with cc 600mm, a bottom plate of particle board and a gypsum board on top. Measurements can also be found in figure 7.3. The market survey carried out in chapter 4 indicates that this type of frame is common, even though it usually is combined with a floating floor and/or a suspended ceiling to achieve the requirements.

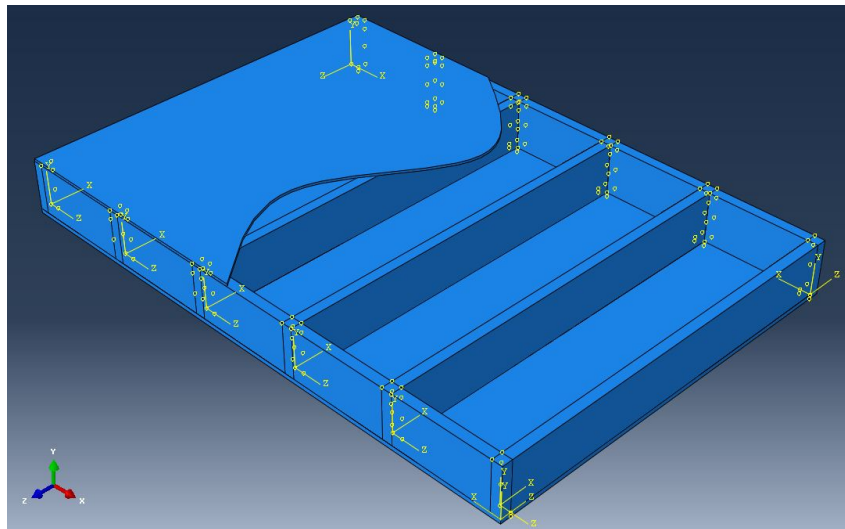

Figure 7.1.: The floors structure.

**Physical Phenomenon**



**Differential Equation**



Approximations

**FEM Equations**



**Mesh**

Figure 7.2.: General explanation of the finite element method.

### 7.3 AIM FOR CALCULATIONS

The main aim for the calculation model is to find out how the new LWA's react at low frequencies (<125 Hz), meaning at what frequencies it can absorb sound. It is assumed that the chosen floor type is best suited for LWA 1, which is why the calculations are limited to this material and LWA 2 is left out. This is based on the outcome of the market survey, where coarser ballast is used when filling out cavities in intermediate floors. A parametric study is carried out where a reference floor (with only air in the cavities) is compared to a number of possible cases where the cavities are filled with various amounts of mineral wool and LWA's. The reason to also test the structure with a combination of mineral wool and LWA is because mineral wool is a commonly used insulation material, and will probably be a part of any insulation solution as it absorbs sound at higher frequencies. Finally the outcome of the calculations will be compared to laboratory measurements done by the consulting firm Akustikverkstan.

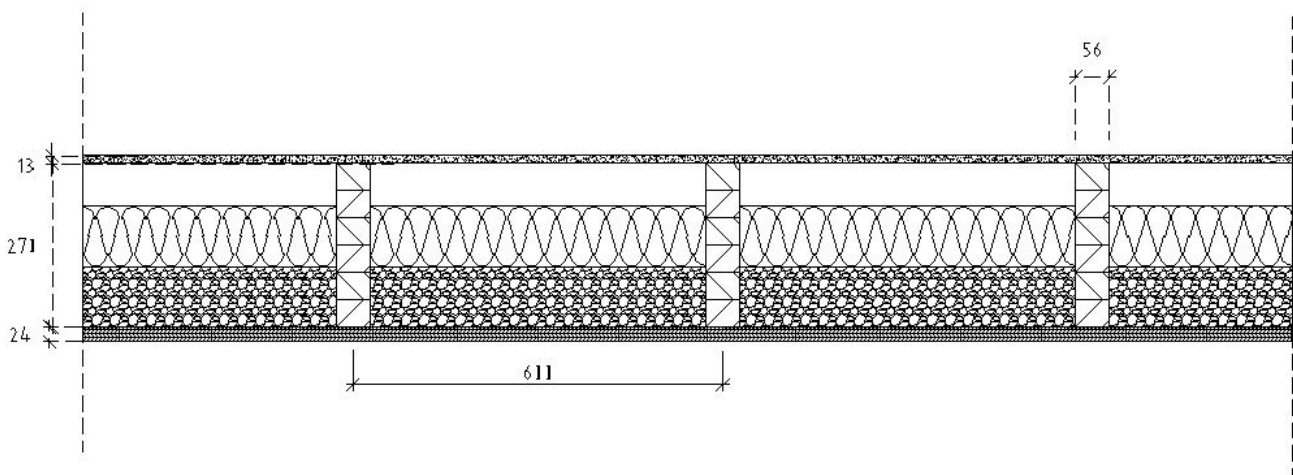

Figure 7.3.: A sketch of the floor slab with measurements.

## 7.4 MODELLING A FLOOR IN ABAQUS

The following subchapters will bring up the modelling in Abaqus and necessary validations of the model. There is also a section where some material parameters have been altered in order to later discuss possible alternations of the materials.

7.4.1 *Defining materials in Abaqus*

As mentioned above, the floor consists of various types of materials that needs to be defined in Abaqus. The frame consists of structural materials that are defined by density, Poisson's ratio, elastic- and shear modulus depending on if the material is isotropic or orthotropic (see table 7.1 and 7.2).

Material	$\rho$ kg/m <sup>3</sup>	E (Mpa)	$\nu$ (-)
Gypsum Board	650	29500	0.13
Particle board	750	340	0.08

Table 7.1.: Material parameters used for isotropic materials [39]

$\rho$	$E_1$	$E_2$	$E_3$	$G_{12}$	$G_{13}$	$G_{23}$	$\nu_{12}$	$\nu_{13}$	$\nu_{23}$
380	9040	790	340	640	580	30	0.5	0.66	0.84

Table 7.2.: Material parameters used for the glulam beams. Wood is considered a orthotropic material [40].  $\rho$  is given in kg/m<sup>3</sup> and E and G in MPa.

The acoustical materials are defined as acoustic fluids <sup>1</sup> by density, bulk modulus and volumetric drag. The bulk modulus ( $K_0$ ) is calculated according to [9] as

$$K_0 = \rho_{air} \cdot c_{air}^2 = 141826 \quad (7.1)$$

where  $\rho_{air} = 1.184$  kg/m<sup>3</sup> and  $c_{air} = 346.1$  m/s [39]. The volumetric drag ( $\gamma$ ) was calculated according to [41] as

$$\gamma = \sigma \cdot \Phi \quad (7.2)$$

where  $\sigma$  is the flow resistivity and  $\Phi$  is the porosity [42] (see table 7.3).

<sup>1</sup> Both mineral wool and LWA will be defined as porous materials. This is an approximation and will not give quite exact calculations but it is a fair approximation

Acoustic material	$\sigma$ (Nsm <sup>-4</sup> )	$\Phi$ (-)	$\rho$ (kg/m <sup>3</sup> )
Mineral Wool	9000	0.99	16
LWA 1	266	0.37	1400

Table 7.3.: Material parameters used for acoustical materials [42]

#### 7.4.2 Workflow for Abaqus

Five separate parts were created: long beams, short beams, bottom plate, top plate, and filling. The four first parts were assembled, creating a frame with five compartments (figure 7.4). To assemble the parts (for example the gypsum board with the beams), partitions had to be made to be able to choose the specific surfaces involved (figure 7.5). When assembling two parts one must choose a master/slave relation. When dealing with this type of construction, this had to be done in the right order because if a surface is chosen to be slave, Abaqus erases all nodes at this surface. If the slave later is chosen as master to another part, there are no nodes left to be tied to the surface. There are no specific rules in how to make the bound between surfaces but in this case the frame was first assembled, choosing the plates to be master surfaces. Then all of the inside of the frame was tied to the filling (air or insulation) that was set to slave. Finally, the filling was partitioned in three layers to make alternations between different combinations of filling materials possible.

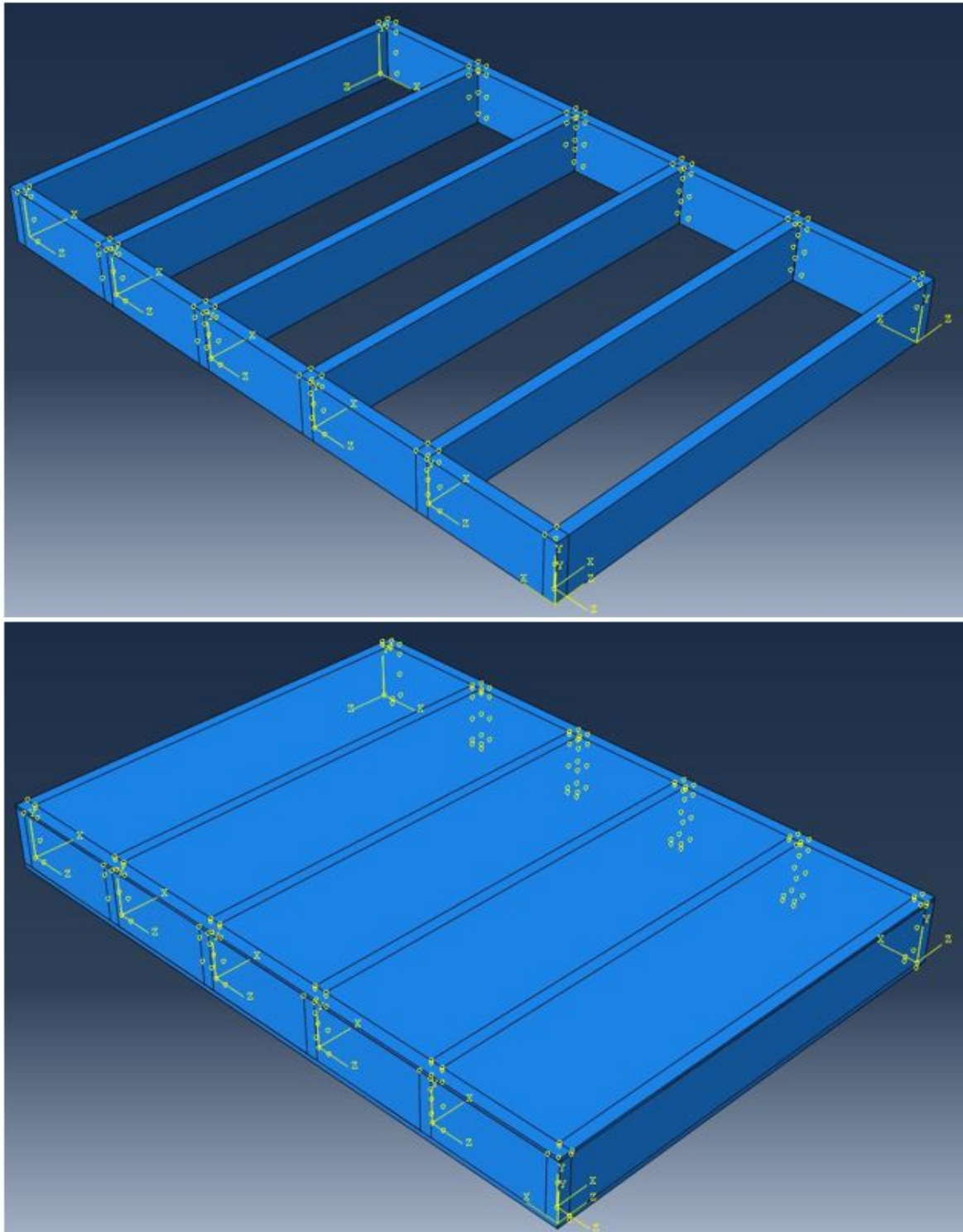

Figure 7.4.: The frame modelled in Abaqus. The upper image shows the frame of beams and the lower image shows both beams and plates assembled creating the entire frame.

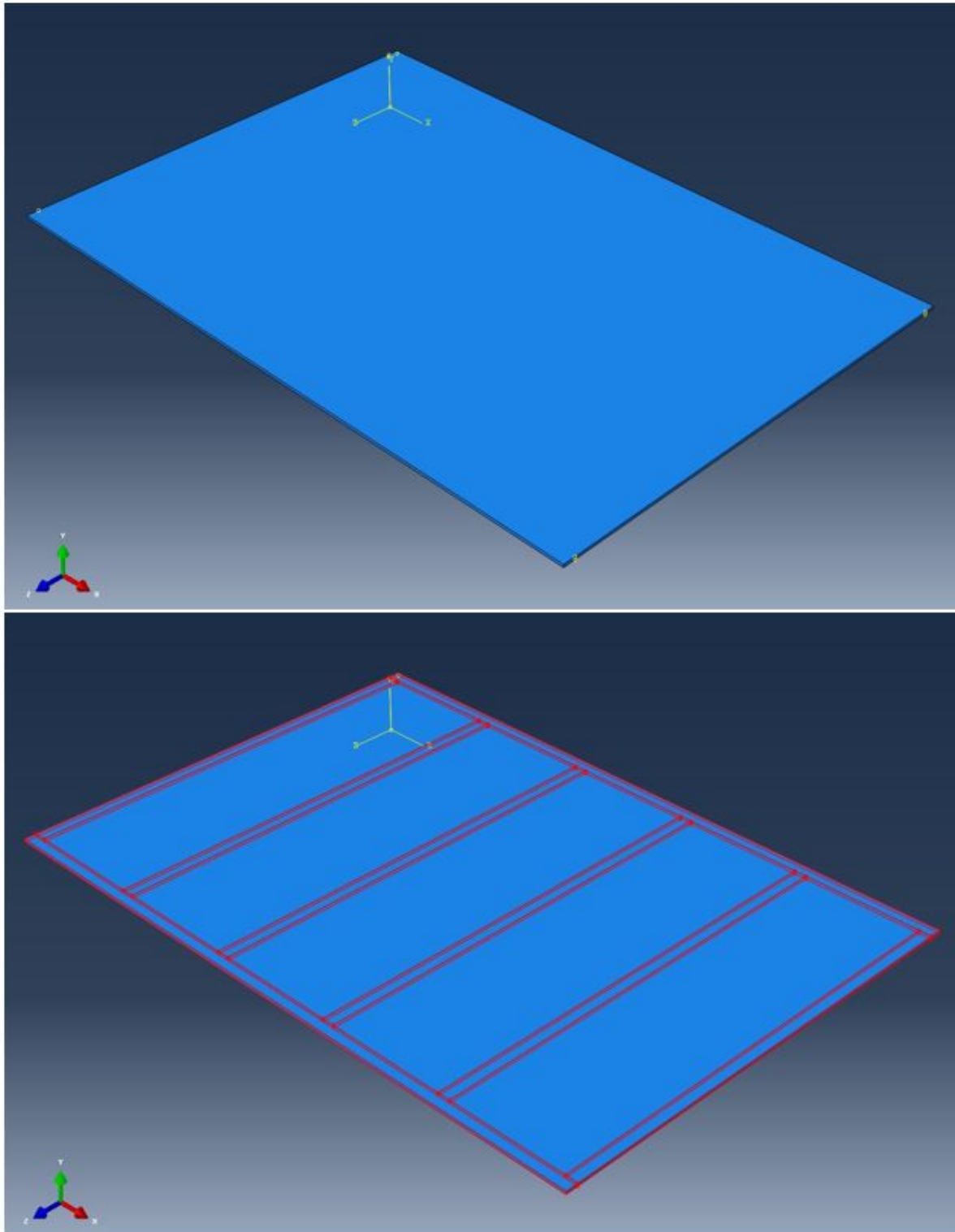

Figure 7.5.: The plate is partitioned, making assembling possible.

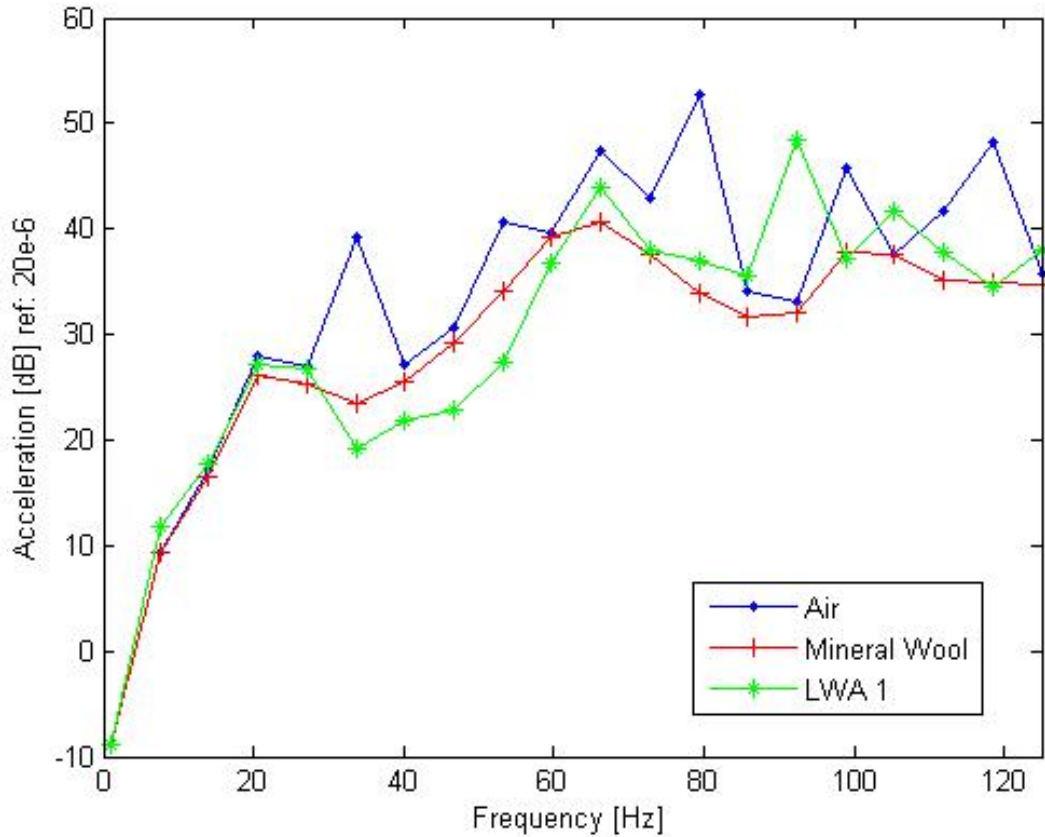

Figure 7.6.: Three plots where the cavities in the Abaqus model is filled with air, mineral wool and LWA 1 respectively.

In the mesh, the frame was set as "3D stress" and the filling inside the cavities was set as "Acoustical". This created a system with both structural and acoustical elements that were tied into one system.

To investigate the floors behaviour, a frequency sweep from 0 to 125 Hz was carried out for the case when a point load was applied at the floor's center point. The point load was in this case an approximation for a footstep or similar. A nodal analysis at  $1/4$  of the bottom plate showed the variation of the accelerations as a function of frequency (see the upper image in figure 7.9). The frequency sweep was made for 3 base cases: only air in the cavities, only mineral wool and only LWA 1 (see figure 7.6). This gave an indication of the materials behaviours and the credibility of the model could be discussed.



### 7.4.3 Validation of the Model

The model was validated by choosing nodes from half of the plate (figure 7.9) and extend the frequency sweep from 0-125 Hz to 0-200 Hz. The results from the validation are plotted in Abaqus (see figure 7.7)

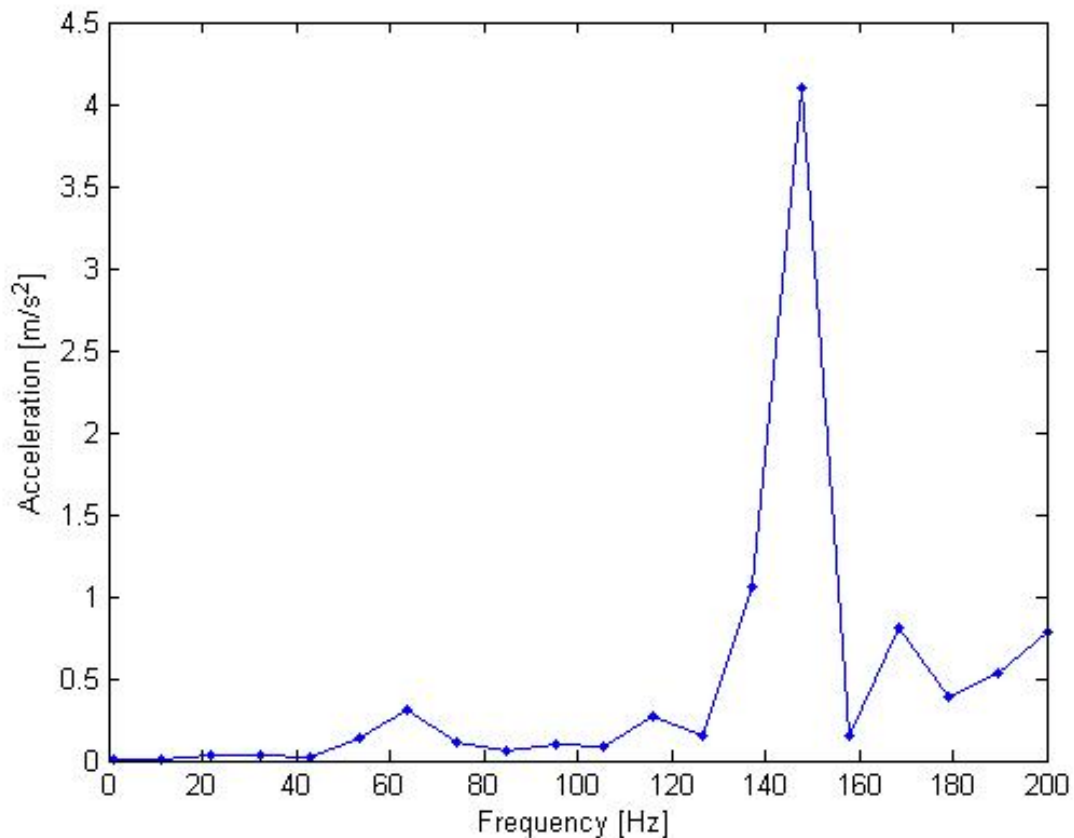

Figure 7.7.: It is validated that the Abaqus model gives the same result for half of the plate as for one fourth of the plate.

Another part of the model that needed validation was the tie between the mineral wool and the top plate. The simulations were made both for the case where the mineral wool was tied directly to the top plate and for the case where a 3mm air gap between mineral wool and top plate was added. In figure 7.8 one can see that the air gap makes no significant difference for the results and therefore the simplest case for a given calculation will be used. This means that the filling will be directly tied to the gypsum board for the case where the entire cavity is filled.

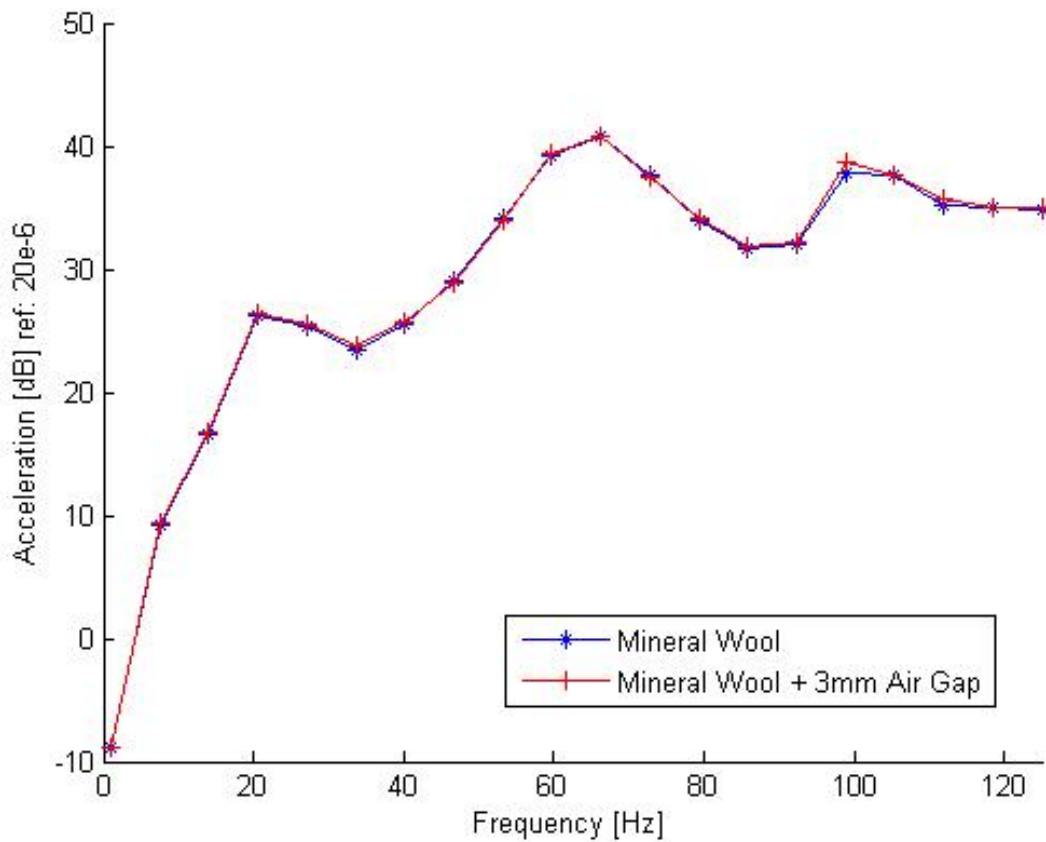

Figure 7.8.: Cavities in the floor are filled with mineral wool. The blue plot shows the case where the mineral wool is tied to the top plate. The red plot shows the case where there is a 3mm air gap between the mineral wool and the top plate.

After the model was validated the materials could be combined. A three-layer combination of air, mineral wool and LWA 1 was tested and the layer thicknesses was altered to find out a suitable combination. Three layer thicknesses of LWA 1 was tried out but the mineral wool layer was constant at 100 mm.

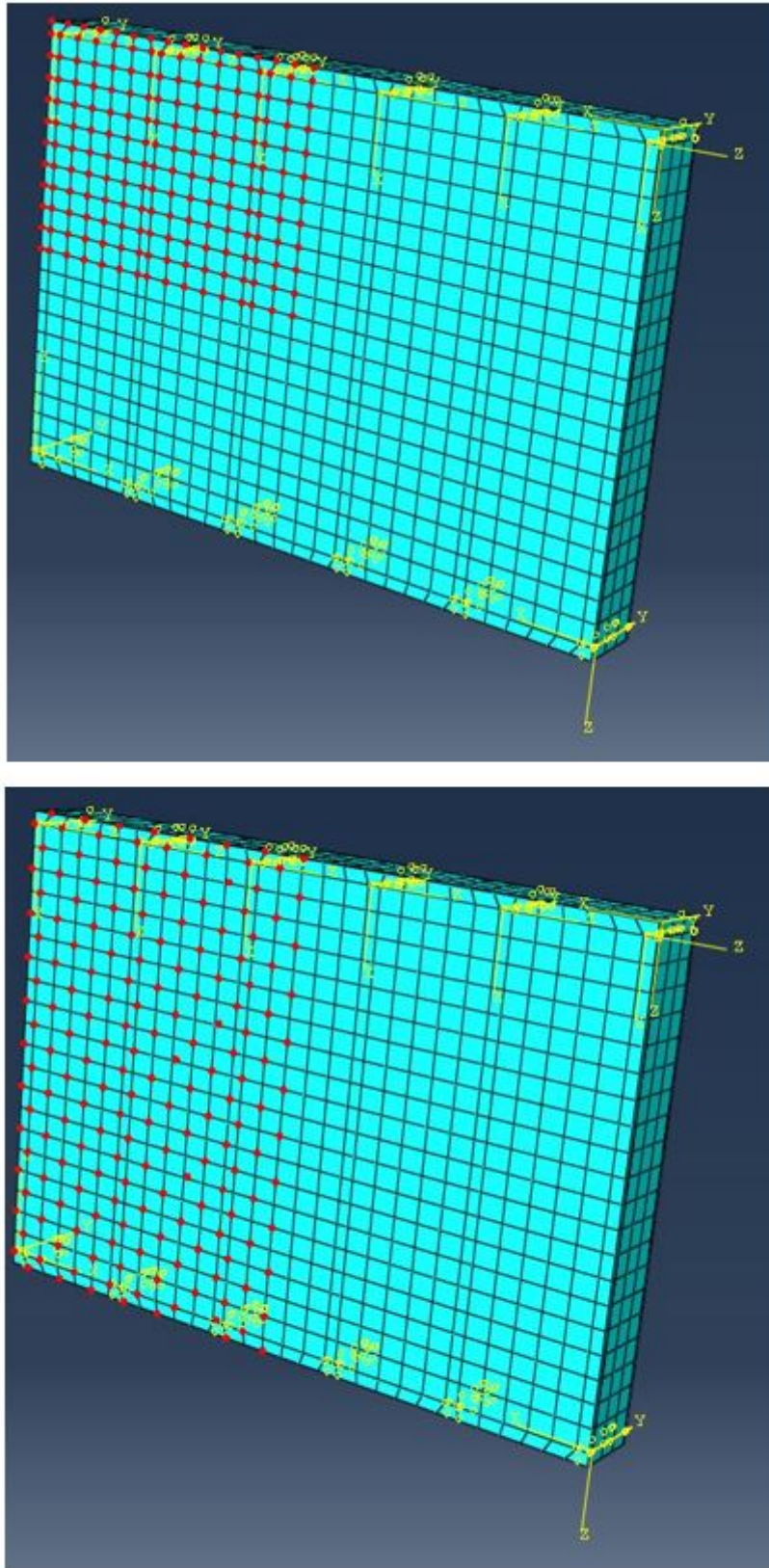

Figure 7.9.: For validation, nodes from half the plate is chosen to find out if it gives the same result as if one fourth of the nodes are chosen.

#### 7.4.4 Alternation of Material Parameters

As the LWA's are under development, there are still a possibility to alter the material parameters to optimize it for the floor insulation application. The volumetric drag (see equation 7.2) was altered to see indications of improvement or deterioration. The volumetric drag for LWA 1 was very low to begin with so the parameter was significantly increased to see if this gave any differences in acceleration. The increase could for example correspond to a flow resistivity of  $\sim 7000 \text{ Nsm}^{-4}$  and a porosity of  $\sim 60\%$ . The density was altered to  $2400 \text{ kg/m}^3$  which is approximately the same as concrete.

#### 7.5 COMPARING RESULTS

The simulation results from Abaqus consists of accelerations in nodes at the bottom plate at 20 frequencies between 0 and 125 Hz. In order to compare different simulations and be able to draw conclusions, this data must be analyzed. In the following subchapters the conversion from accelerations to sound pressure levels (that are comparable with measurements) are presented. The workprocess is described in figure 7.10.

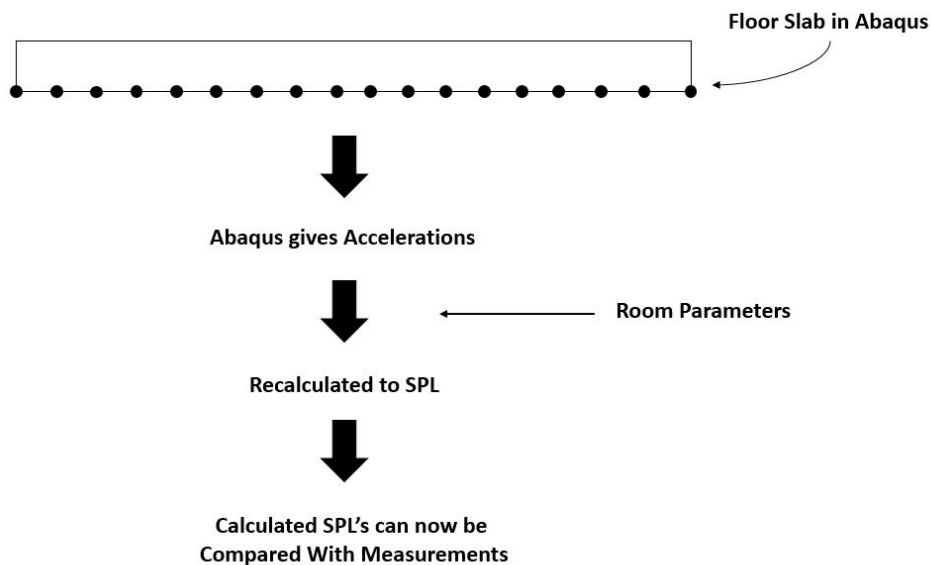

Figure 7.10.: The simulation results are exported from Abaqus as accelerations and recalculated to sound pressure levels with respect to the dimensions of the laboratory at Akustikverkstan. This gave comparable results.

### 7.5.1 Comparing Abaqus Simulation Results

The data was exported from Abaqus and analysed in Matlab (see code example in appendix A). All accelerations were redefined as RMS-values according to [9] and this made it possible to compare different cases in the same plot:

$$\alpha_{RMS}(f) = \sqrt{\frac{1}{n} \sum_{i=1}^n a(f)^2} \quad (7.3)$$

### 7.5.2 Comparing Abaqus Simulation Results With Measurements

In order to compare calculations with earlier measurements done by Akustikverkstan, the accelerations had to be recalculated into sound pressure<sup>2</sup> using relations from equation 7.4.

$$\frac{p}{v} = \rho \cdot c \quad (7.4)$$

where  $p$  is the sound pressure in Pa,  $v$  is the particle velocity in m/s,  $\rho$  is the density in  $\text{kg}/\text{m}^3$  and  $c$  is the velocity of sound in the medium (in this case the medium being air) in m/s. Eigenmode frequencies for the room (meaning the receiving room at Akustikverkstans laboratory) were found using equation 7.5. These frequencies were paired with corresponding sound pressure from the Abaqus simulations.

$$f = \frac{c}{2} \sqrt{\left(\frac{n_x}{L}\right)^2 + \left(\frac{n_y}{W}\right)^2 + \left(\frac{n_z}{H}\right)^2} \quad (7.5)$$

---

<sup>2</sup> This is not an exact comparison as the floor tested at Akustikverkstan has a different structural design.

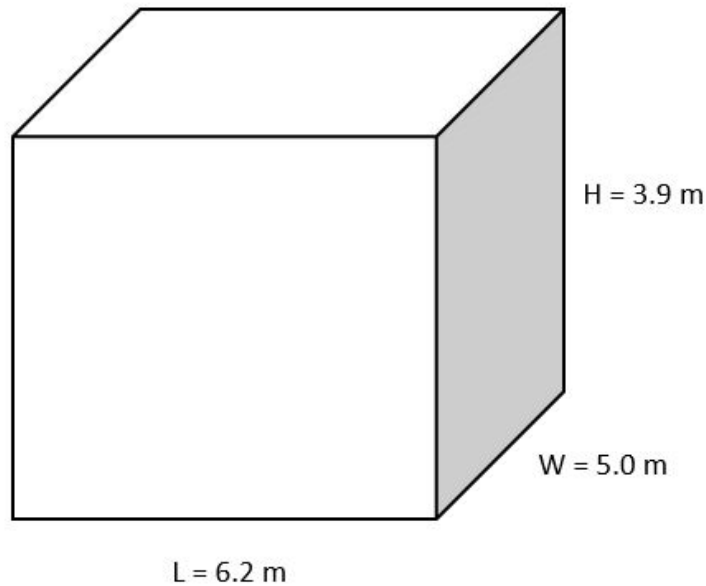

Figure 7.11.: Principle sketch showing the measurements of the receiving room of the laboratory at akustikverkstan

The eigenmodes were calculated with respect to the room measurements of the laboratory at Akustikverkstan (see figure 7.11) where previous measurements have been made. The results from the actual measurements are presented in figure 7.12.

Finally, the sound pressures were described as SPL's using equation 7.6

$$L_p = 10 \cdot \log\left(\frac{\tilde{p}^2}{k \cdot p_{ref}^2}\right) \quad (7.6)$$

where  $k$  is the number of modes,  $\tilde{p}$  is the RMS-value of the sound pressure and  $P_{ref}$  is the reference value  $20 \mu Pa$ .

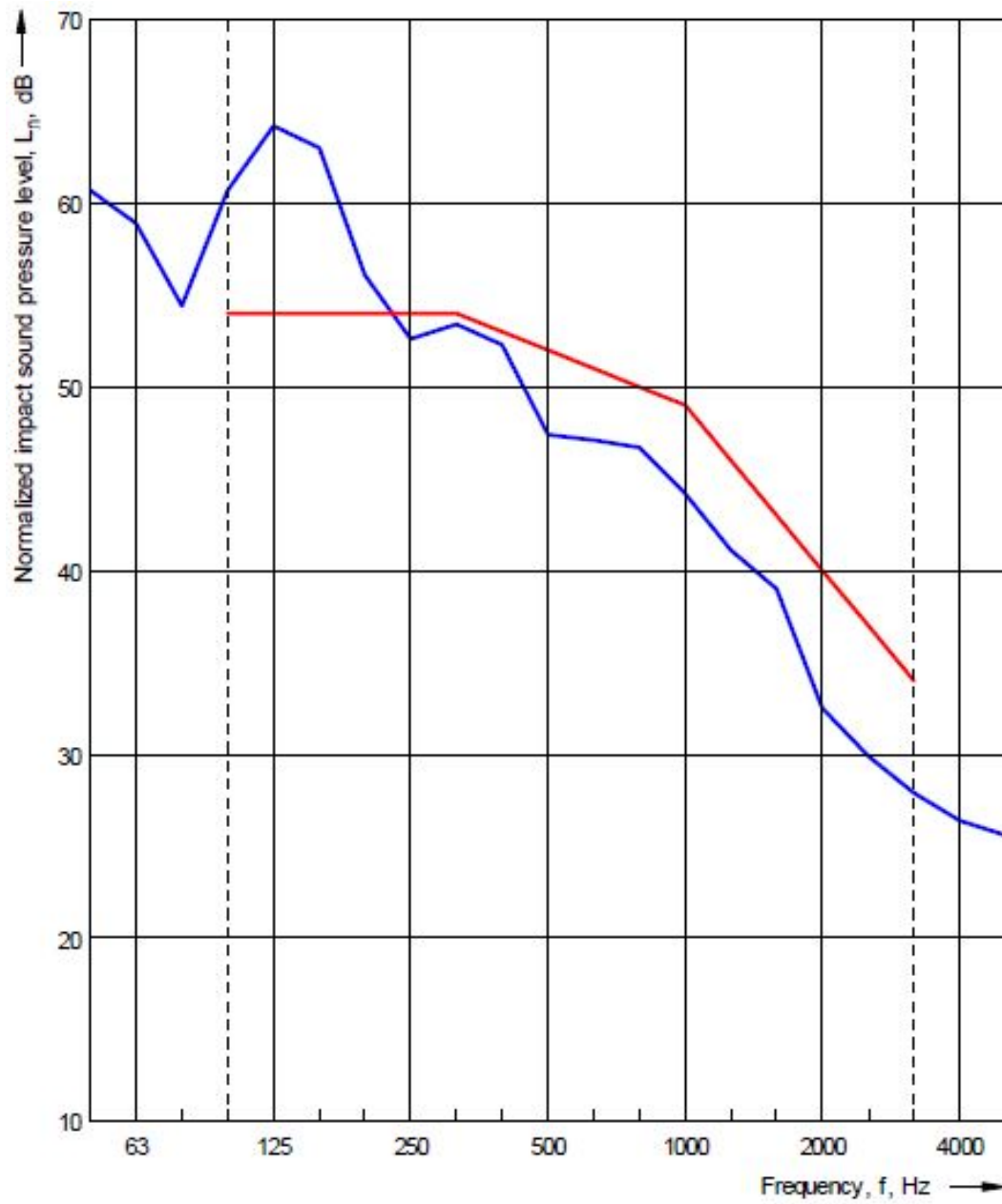

Figure 7.12.: The measurements carried out by Akustikverkstan is done on for a CLT-floor covered with 80mm LWA 1, Isover TDPS 30 and 70mm screed [43]

## 7.6 RESULTS

Results are presented in figure 7.13 where accelerations (in dB) have been plotted at frequencies from 0 to 125 Hz. Figure 7.13 shows the results for when mineral wool and LWA 1 have been combined in the same floor. When comparing the curves it seems that the case with 50 mm LWA 1 and a 100 mm mineral wool is the best case scenario. The curve does not rapidly peak and also decreases around 100 Hz. The three cases does however not vary much from the case where there are only mineral wool in the cavities (see figure 7.6) and the peaks caused by the floor structure is not effectively dampened.

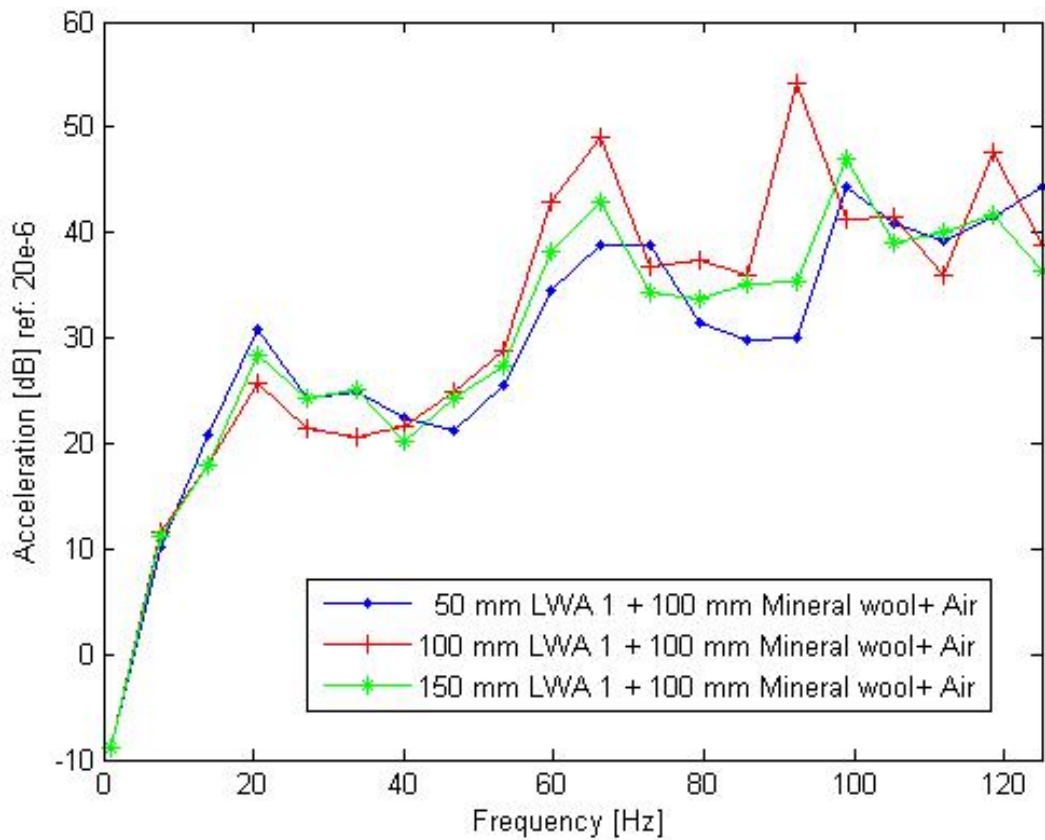

Figure 7.13.: The cavities are filled with various amounts of LWA 1, mineral wool and air



In the two following plots the results are presented in sound pressure level ( $L_p$ ) at some modes in the lower frequency interval (0-125 Hz). This in order to be able to make some comparisons with measurements from Akustikverkstan (measurement results can be viewed in figure 7.12). Figure 7.14 shows the results for the three layer combinations. In this figure one can see that the SPL is lower around 80 Hz for all curves. This corresponds to the results from the measurements from Akustikverkstan (figure 7.12).

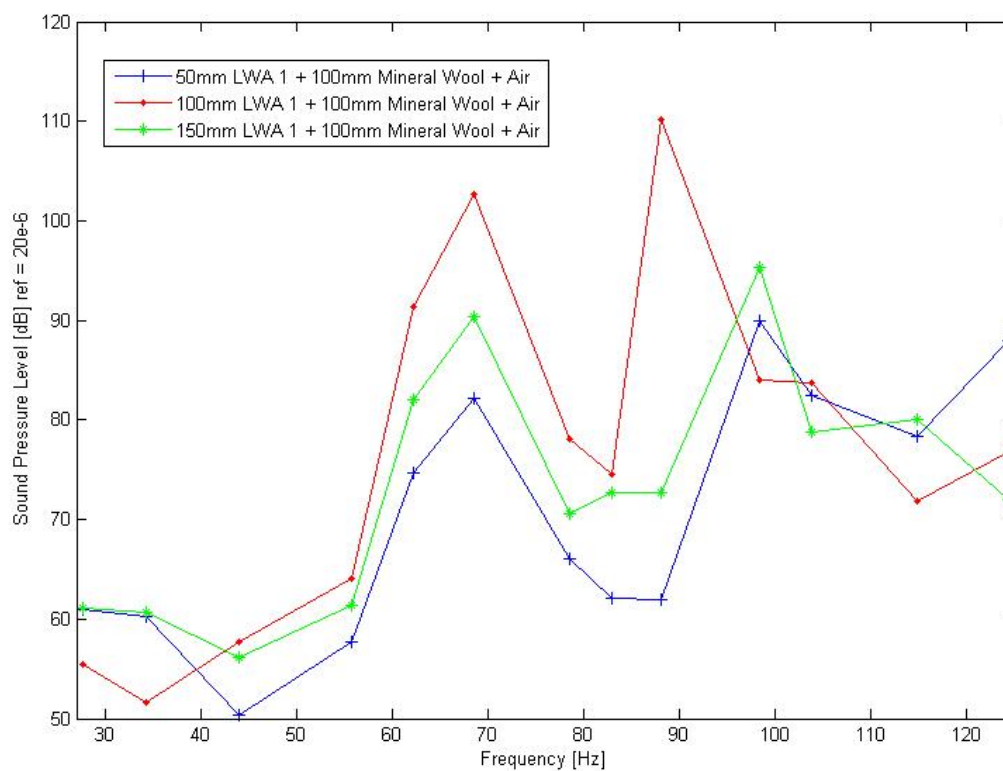

Figure 7.14.: The sound pressure level calculated in some modes for the receiving room at Akustikverkstan

To simplify comparison, the best calculated case for the LWA 1 is plotted together with the case where the cavities are filled with only mineral wool (see figure 7.15). In this figure one can see an improvement in the frequency range from approximately 40 to 90 Hz. At frequencies around 100 Hz and up there is an equally large deterioration and the curve seems to have an up-going trend here.

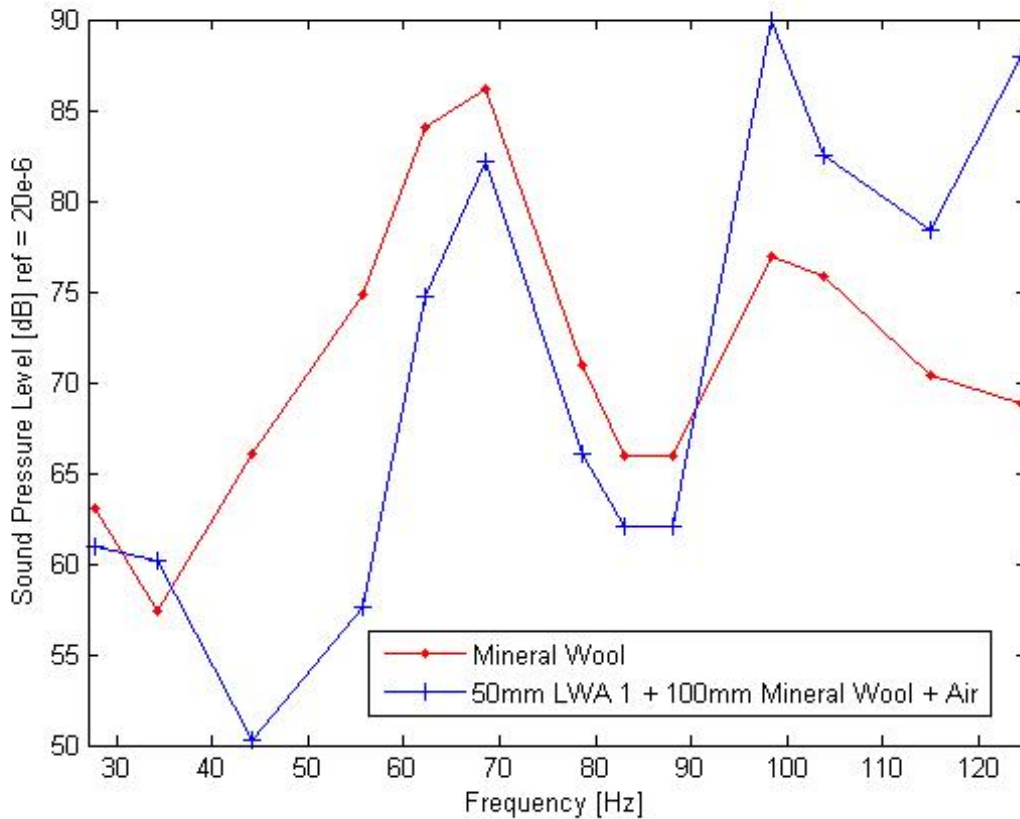

Figure 7.15.: The best case with LWA's are plotted in the same figure as the case where the cavities are filled with mineral wool. This in order to be able to compare and see at what frequencies one can see improvements and deteriorations

The alternation of the volumetric drag and density did not give any significant results as seen in figure 7.16 and 7.17.

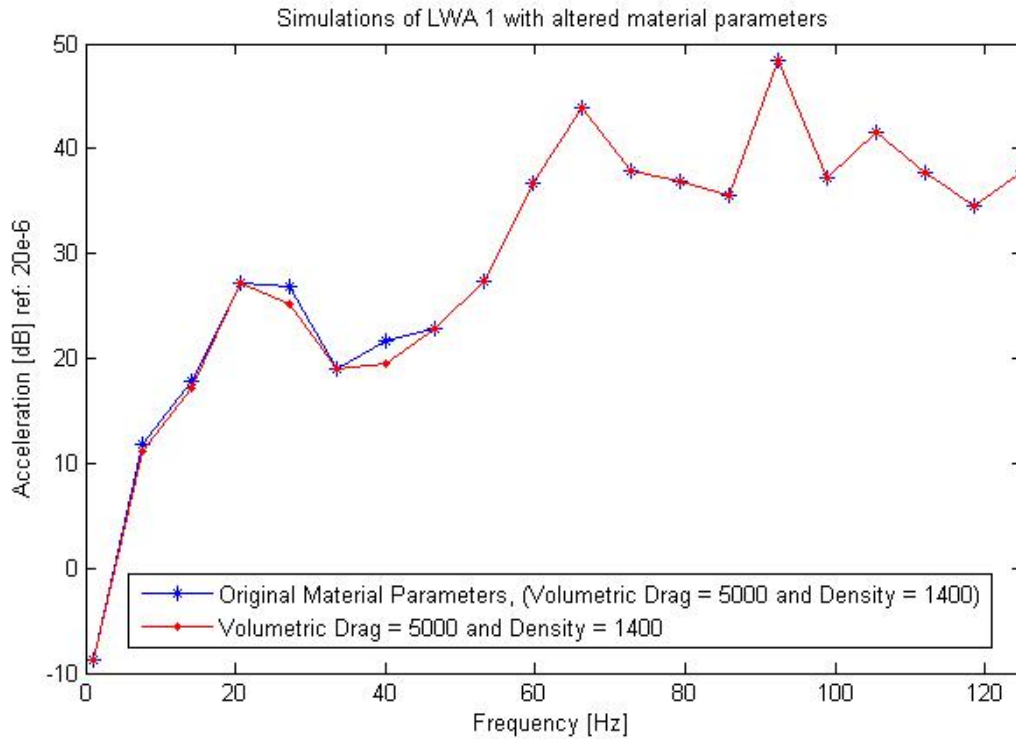

Figure 7.16.: The material parameters have been altered in order to see if change in flow resistivity or porosity can affect the results

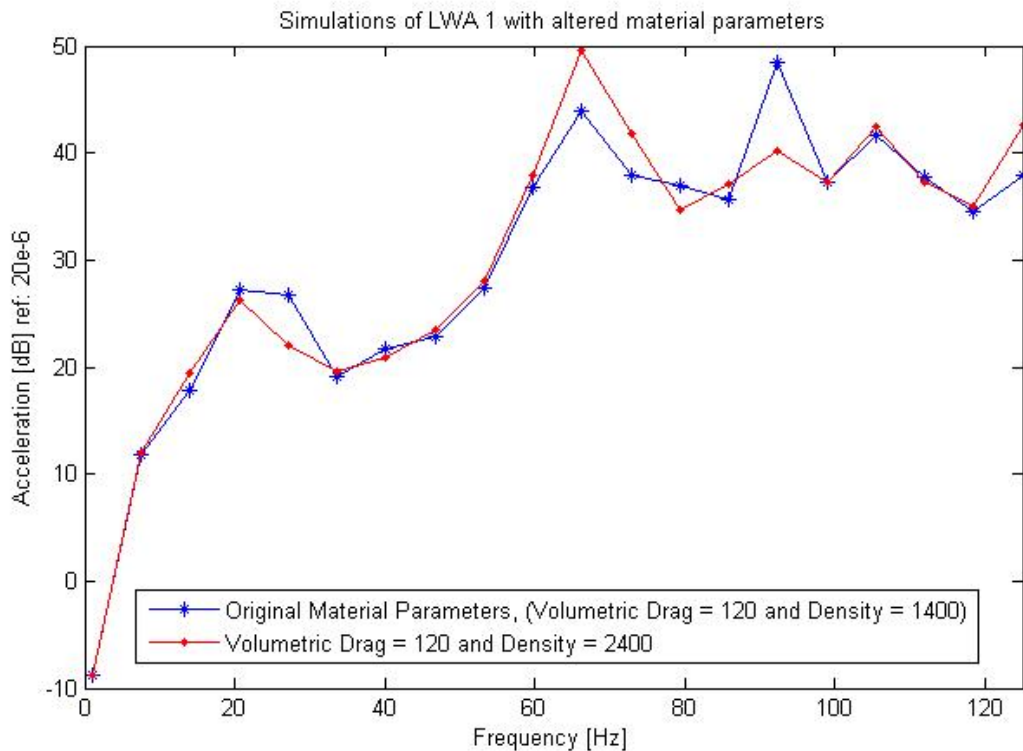

Figure 7.17.: The material parameters have been altered in order to see if change in density can affect the results

## 7.7 CONCLUSIONS FROM ABAQUS SIMULATIONS

The validation of the Abaqus model shows that one does not have to plot all nodes to provide reliable results. It also showed that there was no need for an air gap between the top plate and the material, the results where the same. With the measurements of the laboratory room at Akustikverkstan, it was possible to recalculate the accelerations in the bottom plate of the Abaqus model into sound pressure levels. This made comparison possible and one could see a correlation between the measurements and the calculations. This further validated that the model is reliable. The alternation of the material parameters density, flow resistivity and porosity did not give any significant improvement or deterioration. This implies that if one wants to improve the material, the structure needs to be altered in its structure in other ways.

Part IV

CONCLUSION



---

## DISCUSSION

---

The different parts of the thesis are presented and discussed. Conclusions of the LWA's acoustical properties are presented and future work is proposed.

### 8.1 MARKET SURVEY

The market survey did not reveal what type of load bearing structure that is most commonly used today, but it gave examples of how floor structures could possibly look like in existing buildings. What can be said anyway is that the main economic advantage in timber framed building is that the building process can be sped up when building volume elements. The Economic advantage is an indicator that this will be the most popular building technique in the future, but if the uncertainties in acoustic performance are not solved, light weight buildings may gain a bad reputation.

The floating floor is of importance for sound insulation properties. The technique reduces propagation of vibrations in the primary structure and dampen them out instead. Floating floors are in some extent used in all floor constructions that I have come across during the market survey. When having beams as primary structure, elastomers that are special made for sound insulation sometimes can be installed between the primary and secondary floor structure. For the elastomers to be effective, they must be able to carry the load of the above elements.

One can see that even though wood is used as load bearing structure, it is common that there are layers of concrete somewhere in the floor structure. The concrete layer can interact with the timber as load bearing structure, or be used as a leveler to put the actual floor cover on. Concrete also have a main acoustical advantage over timber: it is heavier and stiffer and this results in less structure borne vibrations in concrete buildings compared to timber framed ones. One main reason to build light weight timber structures is to avoid concrete as it is not very eco-friendly <sup>1</sup>. However, the concrete quantities are much less in these types of timber constructions than if it would have been used as load bearing structure all together.

---

<sup>1</sup> This is a well-discussed subject where one can argue that the concrete binds CO<sub>2</sub> in the manufacturing process. However concrete demands large amounts of virgin materials that can not be recycled

The building materials that was discussed to be replaced by LWA 1 and 2 are concrete, ballast or mineral wool. The building material that bears the most similarities with the LWA's are ballast and is therefore easiest to replace in an existing building solution. As the LWA's material properties are very different from concrete or mineral wool, these materials cannot be replaced without further investigation.

If discussing replacing mineral wool with the new LWA's it is important to take into account that the LWA's have a significantly higher density. In case of replacement from a lighter material, load bearing capacity calculations must be carried out considering the new, heavier material. Another important aspect one always needs to consider when introducing a new material in a building structure is how the material interacts with other materials in terms of moisture. This is of course of greatest importance for the building envelope but should be verified for all building components. It also need to be determined that the material does not contain any toxic substances that could be a health risk for builders and residents. For LWA 1 the issue of glass wool dust should also be considered for them who will handle the material. The joint between outer wall and floor often causes a thermal bridge in which case floor insulation material with good thermal insulation properties can be preferable to reduce this effect.

The price range that was concluded from chapter 5 shows a quite wide range. Depending on if the new materials improve the acoustical performance or not in comparison to other acoustical materials, the price can be set higher or lower. Even with the assumption that the new LWA's can provide with equivalent sound reducing ability, it probably needs to be at the lower price range to be preferred over other proven materials. As the construction industry have an unfortunate history of trying new building materials without properly testing them out first (for example asbestos or rhoca gil), there are a reluctance against trying new materials if they are not properly tested. This sets a greater pressure on the manufacturer (in this case Ecophon) to prove the material to work, not only from an acoustical point of view.

From an environmental viewpoint there are always benefits in reusing residue as this reduces the use of virgin materials in other productions. Today there are not that much focus on EPD's in general in the building industry, but it is likely that this becomes more important in the future as the focus on the environment increases and rules and regulations get stricter. In the future it is likely that the EPD's will play a great role when a building company will choose their material and therefor it can be of interest to optimize them to keep up with the development of the markets future environmental interest. Recycling of waste can then be one of the most important ways to lower the GWP for Ecophons current products. The green building certification systems that where discussed in chapter 5 demanded quite large amounts of recycled material, the quantities being so large that the intermediate floors are insignificant. This does not make it less important to use environmentally friendly materials in the floors, but it can be more difficult to motivate a construction company to use a material that doesn't give any visible results in the certification system.



## 8.2 CALCULATIONS

Analyzing accelerations in the bottom plate for frequencies up to 125 Hz showed no significant improvement when adding LWA 1 into the floor. The accelerations were lowered for frequencies around 40-90 Hz but then again got worse around 100 Hz. To motivate an improvement, the accelerations would have to be lowered for all calculated frequencies. Even if the accelerations in the plate for some frequencies decrease more with LWA 1 added, it is not more than a couple of dB which cannot be considered as a significant improvement. The most likely reason for the LWA's acoustic performance is its lack of stiffness which otherwise is the main reason to add mass. In this case the mass is added without providing the necessary amount of stiffness. The goal of adding stiffness to a light weight construction is to go from the few-mode-range (where the spring stiffness dominates the insulation properties) to the multi-mode-range (where the mass dominates the insulation properties). This is not fully achieved with the LWA.

At frequencies over 20 dB the LWA's show an irregular behaviour where some frequencies are effectively dampened out but some are not. This is an effect of the granular structure that makes the material transmissive. Overall, the mineral wool shows a more predictable curve where there are no sudden peaks at either high or low frequencies.

Finally, it should be mentioned that this thesis is focused on a frequency interval that basically is out of boundaries for the Swedish and European standard today. This makes the analysis of the material quite demanding. Dampening out frequency levels below 50 Hz still remains a discussion and proper calculation- and measuring methods must be found in order to be able to apply it to ISO-standards.

## 8.3 PROPOSAL OF FUTURE WORK

For future work, an investigation of other possible applications for the LWA's might be approached. Maybe investigate if one could replace concrete or ballast rather than mineral wool, and find out if the stiffness of the material could be improved. Maybe the main structure of the material could be changed. It is also of greatest interest to investigate other possible applications for the material. Could it be used in some other area of the building industry, maybe for foundation? If the material will be used as a building material in some extent, it needs to be studied not only from an acoustical approach but all its properties need to be investigated (for example toxic substances and moisture resistance).

Possible applications for the material should be investigated further as the manufacturing process is cheap and energy efficient in comparison to other recycling methods for mineral wool residue. This is of interest for Ecophon, not only from an environmental point of view but also from an economical perspective.



---

## BIBLIOGRAPHY

---

- [1] Rikard Öqvist. *Variations in sound insulation in lightweight timber constructions*. Luleå: Luleå University of Technology, 2010.
- [2] The architects journal. *New innovation from Ecophon*. 2011. URL: <http://www.architectsjournal.co.uk/home/new-innovation-from-ecophon/8613144-fullarticle> (visited on 04/08/2016).
- [3] Erling Nilsson et al. *Grundläggande Akustik*. Lund: Department of constructions sciences, 2008.
- [4] Lakeside audiology. *About your hearing health*. URL: [http://www.lakesideaudiology.com/hearing\\_health.php](http://www.lakesideaudiology.com/hearing_health.php) (visited on 01/26/2016).
- [5] WHO. *Guidelines for community noise*. 1999.
- [6] TutorVista. *Wave Frequency*. URL: <http://physics.tutorvista.com/waves/wave-frequency.html> (visited on 06/31/2016).
- [7] Dakota Ultrasonics. *References*. URL: <http://www.dakotaultrasonics.com/reference/> (visited on 02/02/2016).
- [8] Juan Negreira. *Vibroacoustic performance of wooden buildings - Prediction and perception*. PhD Thesis TVBA-1013. Lund: Department of Construction Sciences, Division of Engineering Acoustics, 2016.
- [9] O flodén and J Negreira and K Persson and G Sandberg. *The effects of modelling acoustic media in cavities of lightweight buildings on the transmission of structural vibrations*. Department of construction sciences, 2014.
- [10] ISO. *Acoustics - Rating of sound insulation in buildings and of building elements- Part 2: Impact sound insulation*. International Organization for Standardization, 1996.
- [11] Tor Erik Vigran. *Building Acoustics*. USA: Taylor Francis, 2008.
- [12] New England Soundproofing. *The facts about impact noise*. URL: [http://www.newenglandsoundproofing.com/facts\\_about\\_impact\\_noise.html](http://www.newenglandsoundproofing.com/facts_about_impact_noise.html) (visited on 05/31/2016).
- [13] Marc Asselineau. *Building Acoustics*. USA: Taylor Francis Group, 2015.
- [14] Per Gunnar Burström. *Byggnadsmaterial -Uppbyggnad, tillverkning och egenskaper*. Danmark: Studentlitteratur, 2007.
- [15] Igor Aranson and Lev Tsmiring. *Granular Patterns*. Oxford: Oxford Scholarship Online, 2008.

- [16] Klas Hagberg and Delphine Bard. "Sound insulations descriptors in Europe- special rules complicate harmonization within lightweight industry". In: *Building Acoustics* (2010), pp. 277–290.
- [17] BBR. *Regelsamling för byggande*, BBR. Boverket, 2015.
- [18] Emma Arvidsson (2016-02-03). *Frågor om de nya granulaten* (F.Sandberg, Interviewer).
- [19] Yifu Gou. *Characterization of Vibro-acoustical Properties of Granular Beds*. Master Thesis. Saint- Gobain Recherche, 2015.
- [20] Thomas Ekenberg. *Stort marknadsintresse att bygga i trä*. 2013. URL: [http://www.skogsindustrierna.org/skog-industri/innehall/skog\\_och\\_industri\\_nyhetsarkiv/nyheter\\_4/stort-marknadsintresse-att-bygga-i-tra](http://www.skogsindustrierna.org/skog-industri/innehall/skog_och_industri_nyhetsarkiv/nyheter_4/stort-marknadsintresse-att-bygga-i-tra) (visited on 03/14/2016).
- [21] Träguiden. *Generell beskrivning av massivträteknik*. URL: <http://www.traguiden.se/planering/planera-ett-trabygge/byggsystem/massivtrateknik/generell-beskrivning-av-massivtrateknik/> (visited on 02/19/2016).
- [22] Brettstapel construction. *Brettstapel*. URL: <http://www.brettstapel.org/Brettstapel/Home.html> (visited on 03/11/2016).
- [23] Klas Hagberg. *Sammanställning av typiska konstruktioner inom Europa av trä och betong*. WSP, 2015.
- [24] Träduiden. *bjälklag*. URL: <http://www.traguiden.se/konstruktion/konstruktionsexempel/bjalklag/> (visited on 04/08/2016).
- [25] Greenspec. *Crosslam timber / CLT - Intermediate floor construction*. URL: <http://www.greenspec.co.uk/building-design/crosslam-timber-intermediate-floors/> (visited on 04/08/2016).
- [26] Lignatur. *Home*. URL: <http://www.lignatur.ch/en/home/> (visited on 02/17/2016).
- [27] Lignatur. *Workbook*. URL: [http://www.lignatur.ch/fileadmin/ablage/downloads/workbook\\_a4\\_en/2014-06-04\\_workbook\\_a4\\_en\\_schallschutz.pdf](http://www.lignatur.ch/fileadmin/ablage/downloads/workbook_a4_en/2014-06-04_workbook_a4_en_schallschutz.pdf) (visited on 04/08/2016).
- [28] Roberto Crocetti et al. *Design of Timber Structures*. Malmö: Swedish Wood, 2011.
- [29] Kevin Dunne. *Stegljudsmätning vid Ånäskolan*. Lokalförvaltningen, 2014.
- [30] Träguiden. *Casa Nova i Danmark*. 2003. URL: <http://www.traguiden.se/konstruktion/konstruktionsexempel/ljudisolering/ljudisolering/casa-nova-i-danmark1/> (visited on 04/08/2016).
- [31] Optimera Lund (2016-03-07). *Materialförsäljning* (F. Sandberg Interviewer).
- [32] Marcus Dehlin (2016-03-07). *Materialförsäljning* (F. Sandberg Interviewer).
- [33] Wikells Byggberäkningar AB. *Sektionsfakta - NYB 12/13*. Växjö: Elanders, 2012.
- [34] Anna Palminger (2016-03-21). *Miljödiskussion* (F. Sandberg Interviewer).

- [35] European Commission. *Directive 2008/98/EC on waste (Waste Framework Directive)*. URL: <http://ec.europa.eu/environment/waste/framework/> (visited on 03/21/2016).
- [36] Sweden Green Building Council. *BREEAM*. Sundbyberg, 2013.
- [37] USGBC. *Recycled content*. 2009. URL: <http://www.usgbc.org/credits/commercial-interiors-retail-ci/v2009/mrc4> (visited on 04/18/2016).
- [38] Niels Ottosen and Hans Pettersson. *Design of Timber Structures*. Edinburgh: Prentice Hall Europe, 1992.
- [39] Acoustics. *Material Properties*. URL: <http://www.akustik.lth.se/fileadmin/tekniskakustik/education/VTAF05/MaterialProperties.pdf> (visited on 05/04/2016).
- [40] Kristian Berbom Dahl. *Mechanical properties of clear wood from Norway spruce*. Norway: Faculty of Engineering Science and Technology, Department of Structural Engineering, 2009.
- [41] Abaqus analysis user's manual. *Acoustic medium*. URL: <http://web.byggmek.lth.se:2080/v6.11/books/usb/default.htm?startat=pt05ch25s03abm57.html#usb-mat-cacousticmed-define> (visited on 05/04/2016).
- [42] Jean-Francois Allard and Philippe Herzog and Denis Lafarge and Masayuki Tamura. *Recent topics concerning the acoustics of fibrous and porous materials*. Laboratoire d'Acoustique Associé au CNRS, 1991.
- [43] Pontus Thorsson. *Laboratory measurements for floor constructions for Saint-Gobain Ecophon AB according to SS-EN ISO 10140-2:2010 and 10140-3:2010*. Tech. rep. 2016.



---

## LIST OF FIGURES

---

Figure 1.1	to the left: LWA 1 and to the right: LWA 2 [2]	12
Figure 2.1	The ear[4]	15
Figure 2.2	Correspondence between sound pressure level (SPL) and sound pressure (SP)	16
Figure 2.3	Frequencies and amplitudes contra the perception of sound. Inspiration from [6]	17
Figure 2.4	Frequencies can be divided in bands. This piano shows an octave.	18
Figure 2.5	Principle sketch of the sound reduction/frequency dependence for a single wall [3]. The few-mode range is typical for light weight constructions and the multi-mode range is typical for heavy constructions.	19
Figure 2.6	The sound reduction for a double wall with and without insulation in the cavities. As a reference, a single wall with the same weight as the double wall is also plotted [3].	20
Figure 2.7	Flanking transmission. Inspired by [3]	21
Figure 2.8	Parts of the sound wave energy is converted into heat. The rest transmits through the material.	23
Figure 2.9	Visualisation of impact noise [12].	24
Figure 2.10	Difference between a laboratory case (left) and a field case (right) [11].	25
Figure 2.11	The difference between "grain" and "granular".	26
Figure 3.1	LWA 1 used at a landfill in Landskrona	30
Figure 3.2	LWA 2 manufactured in laboratory	31
Figure 4.1	General sketch of a CLT element [25]. The slab is covered with a layer of concrete with impact sound insulation layer on top.	36
Figure 4.2	2D model of a cassette structure with inspiration from [24]	37
Figure 4.3	Example of box element floor slab with inspiration from [27]. This box element is filled with ballast and there are three material layers (honeycomb fill, sound impact insulation and screed) on top.	38
Figure 4.4	Example of a glulam floor [30]. Stratigraphy from the top: sand, sound impact insulation board, particle board, glulam beams with mineral wool and two layers of gypsum.	39
Figure 4.5	The volume elements are prefabricated and assembled at the construction site. In order to prevent sound transmission between elements, an elastomer is put between the elements. [1]	40

- Figure 4.6 Example of assembly between volume elements creating a floor slab [1]. 41
- Figure 6.1 EUs waste hierarchy [35] 49
- Figure 7.1 The floors structure. 54
- Figure 7.2 General explanation of the finite element method. 54
- Figure 7.3 A sketch of the floor slab with measurements. 55
- Figure 7.4 The frame modelled in Abaqus. The upper image shows the frame of beams and the lower image shows both beams and plates assembled creating the entire frame. 58
- Figure 7.5 The plate is partitioned, making assembling possible. 59
- Figure 7.6 Three plots where the cavities in the Abaqus model is filled with air, mineral wool and LWA 1 respectively. 60
- Figure 7.7 It is validated that the Abaqus model gives the same result for half of the plate as for one fourth of the plate. 61
- Figure 7.8 Cavities in the floor are filled with mineral wool. The blue plot shows the case where the mineral wool is tied to the top plate. The red plot shows the case where there is a 3mm air gap between the mineral wool and the top plate. 62
- Figure 7.9 For validation, nodes from half the plate is chosen to find out if it gives the same result as if one fourth of the nodes are chosen. 63
- Figure 7.10 The simulation results are exported from Abaqus as accelerations and recalculated to sound pressure levels with respect to the dimensions of the laboratory at Akustikverkstan. This gave comparable results. 64
- Figure 7.11 Principle sketch showing the measurements of the receiving room of the laboratory at akustikverkstan 66
- Figure 7.12 The measurements carried out by Akustikverkstan is done on for a CLT-floor covered with 80mm LWA 1, Isover TDPS 30 and 70mm screed [43] 67
- Figure 7.13 The cavities are filled with various amounts of LWA 1, mineral wool and air 68
- Figure 7.14 The sound pressure level calculated in some modes for the receiving room at Akustikverkstan 69
- Figure 7.15 The best case with LWA's are plotted in the same figure as the case where the cavities are filled with mineral wool. This in order to be able to compare and see at what frequencies one can see improvements and deteriorations 70
- Figure 7.16 The material parameters have been altered in order to see if change in flow resistivity or porosity can affect the results 71
- Figure 7.17 The material parameters have been altered in order to see if change in density can affect the results 72



---

## LIST OF TABLES

---

Table 2.1	Velocity of sound in steel and air [3] [7].	18
Table 2.2	Sound classifications described in dB [9]	21
Table 2.3	Impact sound requirements in some European countries [16].	27
Table 3.1	Summary of mechanical parameters for LWA 1 and LWA 2	30
Table 5.1	Price levels for an approximate layer size of 100 mm for mineral wool, concrete and gravel [33]	47
Table 5.2	Price levels for the materials mentioned in 5.2 after a 50 % discount	48
Table 7.1	Material parameters used for isotropic materials [39]	56
Table 7.2	Material parameters used for the glulam beams. Wood is considered a orthotropic material [40]. $\rho$ is given in $kg/m^3$ and E and G in MPa.	56
Table 7.3	Material parameters used for acoustical materials [42]	57



---

## ACRONYMS

---

<b>BBR</b>	Boverkets Byggregler
<b>BREEAM</b>	BRE Environmental Assessment Method
<b>cc</b>	Center Distance
<b>CLT</b>	Cross Laminated Timber
<b>EPD</b>	Environmental Product Declaration
<b>FEM</b>	Finite Element Method
<b>GWP</b>	Global Warming Potential
<b>LEED</b>	Leadership in Energy and Environmental Design
<b>LWA</b>	Light Weight Aggregate
<b>PBL</b>	Plan- och Bygglagen
<b>RMS</b>	Root Mean Square value
<b>SPL</b>	Sound Pressure Level
<b>SP</b>	Sound Pressure
<b>WHO</b>	World Health Organization



Part V

APPENDIX





---

## APPENDIX A

---

Abbreviated Matlab code:

```
SCRIPT 1: calculating RMS values of accelerations
clear all
close all
Aair = [1. 0. 6.26316 0. ... .. 95.7368 35.0665E-03 101. 650.508E-03];
plockar ut alla accelerationer från matrisen ANOAIR aAcc = Aair(:,2);
skapar en vektor med de plateser jag vill hämta ut från aAcc steps = zeros(104,1); n =
length(steps);
-----step 1-----
for i=0:103 steps(i+1)=(20*i+1); end
steps
b1 = 0;
for j = 1:length(steps) b1= b1 + (aAcc(steps(j)))2; end
a1 = sqrt((1/n)*b1)
repeat for-loops for all steps
-----Plottar Acceleration för air-----
ploty = [a1 a2 a3 a4 a5 a6 a7 a8 a9 a10 a11 a12 a13 a14 a15 a16 a17 a18 a19 a20]
plotx = [1. 6.26316 11.5263 16.7895 22.0526 27.3158 32.5789 37.8421 43.1053 48.3684 53.6316
58.8947 64.1579 69.4211 74.6842 79.9474 85.2105 90.4737 95.7368 100];
-----export acceleration matrix to plot-script-----
SCRIPT 2: plot accelerations
-----matriser med accelerationen uttryckt i decibel-----
air = [2.64717810289984e-06 ... 0.0367994185024515 2.20246271491814]; MU =
[2.59428041695602e-06 ... 0.0351238624620481 0.220736064176765]; EcoDrain =
[2.62102761352813e-06 ... 0.164379650574898 0.199554458456087];
a,ef = 20e - 6;
airplot = 10*log10(air/a,ef); MUplot = 10 * log10(MU/a,ef); EcoDrainplot = 10 *
log10(EcoDrain/a,ef);
frekplot = [1. 6.26316 11.5263 ... 95.7368 100];
```

```
figure(1) plot(frekplot, airplot, '-') hold on plot(frekplot, MUplot, '- r') hold on plot(frekplot,  
EcoDrainplot, '- g')  
xlabel('Frequency [Hz]') ylabel('Acceleration [dB] ref: 20e-6') title("")
```