



ADAPT: *A new resilient living in a Kampala post-industrial area*

ACKNOWLEDGEMENT

This thesis comes to reality as a result of kind support and help from a number of Individuals. I would like to extend my sincere thanks to them.

First, I would like to thank my supervisors Laura Liuke and Louise Lövenstjerne for their time and expert input into this project. I would in the same light like to thank the Sustainable Urban Design Faculty for the great learning experience.

Secondly, I am very grateful the Swedish Institute without whose financial backing all this would not have been possible.

Thirdly, I would also like to thank my family for both the financial and moral support that they provided during this time.

Lastly but not least, all glory and honour goes to God for the wisdom, strength, peace of mind and good health to complete this research.

Arnold Mwirumubi Nyawanga

TABLE OF CONTENTS

CHAPTER I	FOREWORD			
1.1	Africa	1		
1.2	Kampala	1		
CHAPTER II	INTRODUCTION			
2.1	Location	2		
2.2	History and Structure	3		
CHAPTER III	CLIMATE	4		
CHAPTER IV	DEMOGRAPHICS AND GROWTH	6		
CHAPTER V	THE CITY			
5.1	Functions and Land use	7		
5.2	Ecology	8		
5.3	Connections	9		
CHAPTER VI	RESEARCH SUMMARY			
6.1	Summary of Challenges	10		
6.2	Research Questions	10		
6.3	Goal	10		
6.4	Objectives and General Strategy	11		
CHAPTER VII	THE DESIGN PROJECT			
7.1	Site Selection Criteria	12		
7.2	The Site	13		
7.2.1	Site Characteristics	14		
7.2.2	Existing Functions	15		
7.2.3	Existing Connections	16		
7.2.4	Site Climate Analysis	17		
7.2.5	Site Storm Water Analysis	18		
CHAPTER VIII	THE DESIGN PROPOSAL			
8.1	Site Development Phasing Strategy	20		
8.2	Site Development Phase 1	22		
8.3	Flood Mitigation Strategy	24		
8.3.1	Urban Greening	25		
8.3.2	Nakivubo Canal Strategy	26		
8.3.3	Street Strategy	27		
8.3.4	Built environments Strategy	28		
8.3.5	Flood Proofing integration in buildings typologies	29		
8.4	Design Drawings			
8.4.1	Site Plan	30		
8.4.2	Detailed Design (Mixed Use Community)	31		
8.4.3	Design Sections	32		
8.4.4	Artistic Impressions	35		
CHAPTER IX	PROJECT SUMMARY AND CONCLUSION	37		
CHAPTER X	BIBLIOGRAPHY	38		

1.FOREWORD

1.1.AFRICA

Despite Urban and demographic developments of the past decades having already presented a major challenge for African cities in providing socially just, sustainable and well serviced living and working environments for their rapidly increasing Urban populations, the current climate and environmental changes have greatly aggravated these challenges. UN Habitat(2014).

According to UNHabitat, (2014), Africa's urban population is still below the 50% urban threshold meaning major re-conceptualization of its approach to Urbanism is still possible. With vastly changing global conditions especially in the areas of climate and environment change, African cities have the opportunity to take a global lead in innovations. A resilient approach to Urban design is thus important in the future development of cities not only in Africa but the world at large.

1.2. KAMPALA

Kampala is rapidly urbanising with the population explosion putting stress on the city and services with transport,housing and employment being the areas most affected. With congested streets, limited and or low quality housing coupled with high unemployment,. As a result, informality and inequality have become entrenched in the fabric of the city. This is a challenge clearly portrayed in the existing settlement on unplanned land without public services and bulk infrastructure, unregistered housing construction and transfer, informal and insecure jobs as well as unregulated trade and service provision. (Taylor and Camaren,2014). These challenges as mentioned earlier are and will continue to be aggravated by climate change.

"In the light of the threats posed by changing climatic conditions and the prevailing realities of economic and political dis empowerment, how might we go about grounding and working with the idea of climate compatible development so that we can envision and build new urban futures in cities across Africa that are vibrant, inclusive and sustainable?"(Taylor and Camaren,2014).

The answer lies in designing cities to be resilient and forward-looking. This thesis focuses on the development of an Urban design strategy that builds resilience towards climate change while tackling the base challenges facing a rapidly urbanising and expansion of Kampala City.

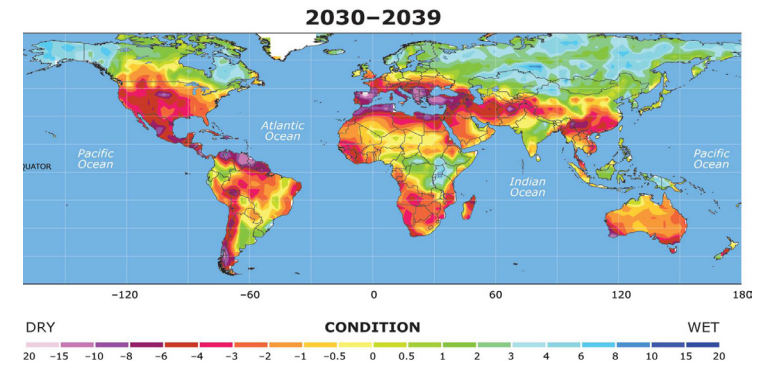

Global Climate Change effect Prediction

Source: ScienceTalerter

Accessed at: http://madtilmilliarder.sciencetalenter.dk/artikler-og-viden/?tx_colab_articles%5Bsubject%5D=163&tx_colab_articles%5Baction%5D=show&tx_colab_articles%5Bcontroller%5D=Subject&cHash=df567f61d30afe8d7596fa592040320



Flash Floods in Kampala

Photo credit: Waswa Balunywa

2. INTRODUCTION

2.1. Location

Kampala is the administrative and commercial capital of Uganda. It is located 0.3476° N, 32.5825° E and covers approximately 189 sq. Kilometres. Kampala is bordered 8km to the south by lake Victoria and Wakiso district to the North, East, West and Southwest. Initially planned covering four hills, Kampala City has expanded and now covers 24 hills with an average height of 1120m. The hills mainly have steep upper slopes, merging into undulating slopes and ending into broad shallow valleys. Kampala is also defined and structured by extensive papyrus swamps, and perennial streams/channels.

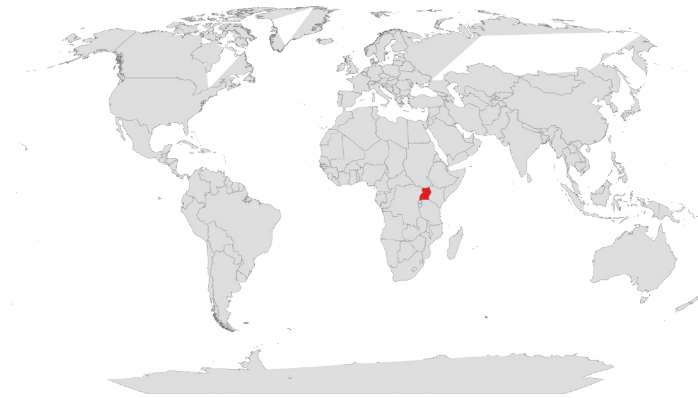

Location of Uganda in the Global Context



Location of Kampala within Uganda

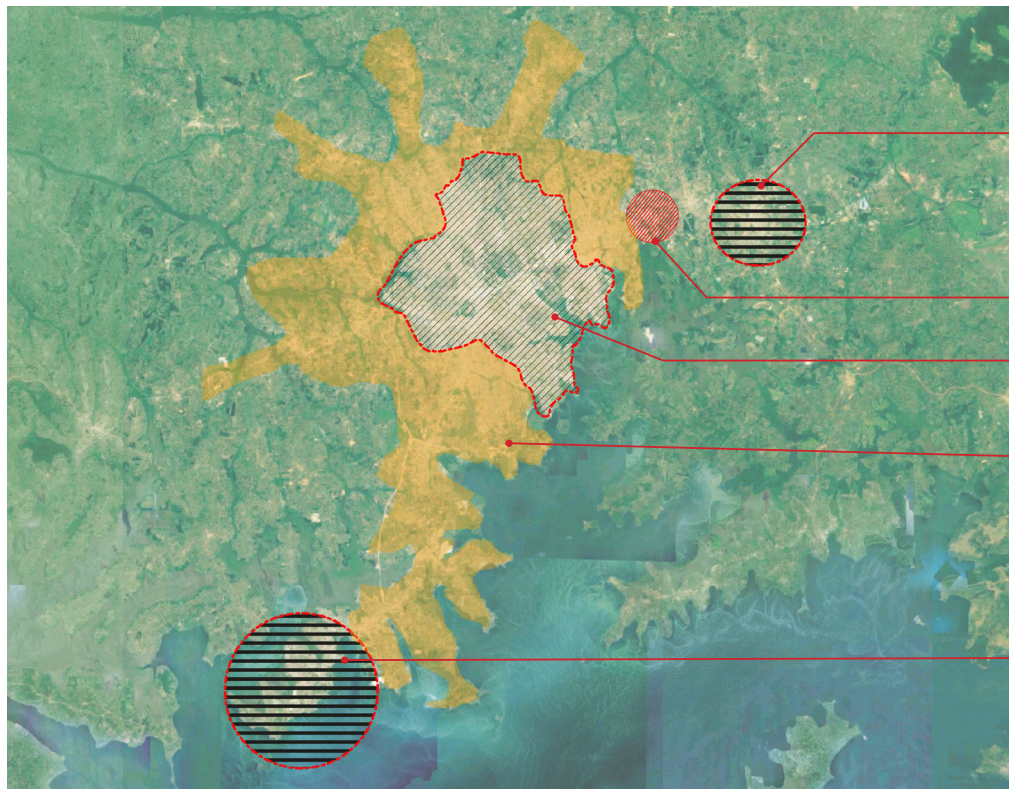

Mukono Town

Proposed Kampala Industrial and Business Park

Kampala City

Greater Metropolitan Kampala

Entebbe Municipality

Location of Kampala and its immediate surroundings

2.2. History and Structure

Kampala was historically located next to the capital (kibugga) of one of the larger Kingdoms in Uganda; the Buganda kingdom which was ruled by His royal highness the Kabaka. The kingdom was divided into districts each ruled by a chief and separated by swamps, rivers and cultivated gardens that marked the different borders. The capital changed from one hilltop to another with the coronation of a new King. However, in 1884 it was moved to Mengo by the then King Mwanga and has remained there until today.

The British colonial government allied themselves with the Buganda Kingdom as signed an agreement in 1900 with the Kabaka and his chiefs creating the first sparks of what grew into the current day Kampala. Like many Colonial cities, Kampala was designed along racial segregation lines: viz., African, Asian and European. Over time the city has evolved having different influences and long standing effects that are still seen in present day Kampala.

According to Omolo(2010), Kampala was gazetted as a township in 1902 and was granted Municipal status in 1950, when a Council was appointed with a Mayor as its head. Kampala became a city by the Royal Charter of 28th September 1962 and became Uganda's capital city at independence the same year.

Kampala city is a District under the Decentralization Act 1997 and has five political and administrative divisions (municipalities) namely; Central, Nakawa, Kawempe, Rubaga and Makindye. At the administrative and Management level, the Capital City is with effect from March 2011 headed by the Executive Director (financial officer), who is directly appointed by the President of the Republic of Uganda.

Kampala today accounts for 31.2% of Uganda's total urban population. This urban population of 3.5 million is predicted rise to nearly 8-10 million by 2030. According to the Kampala Physical development Plan(KPDP),2012 Kampala today is estimated to house around 3.15 million persons in some 800,000 households in the Greater Kampala Metropolitan Area(GKMA) with some 1.75 million in the Kampala City Council Authority (56%) and some 1.4 million in the Kampala Metropolitan Trading Centres KMTC (44%).

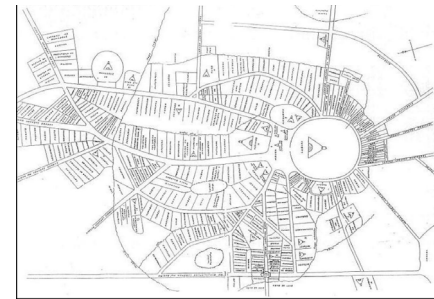

Plan of the Kibuga 1858 (Source: Roscoe, 1911 in: P.C.W Gutkind, 1960 in: Omollo 2010)

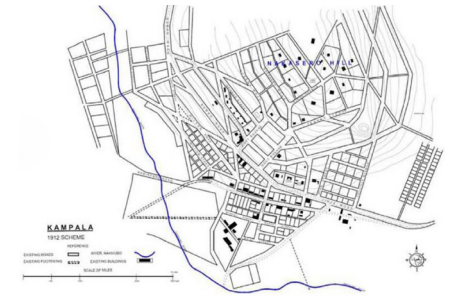

The First Planning Scheme for Kampala 1912 (source: Kendall, 1955: Omollo 2010)

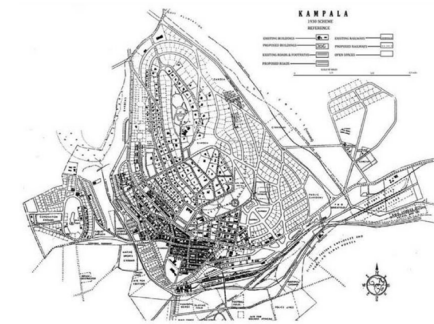

Mirams 1930 scheme for Kampala (source: Kendall 1955 in: Omollo 2010)



The Ernst May plan 1945 (source: Uganda Museum)

3. CLIMATE

Uganda has a variant climate that is tropical and equatorial. There are two main seasons, the wet and the dry season although precipitation can be expected all year round in regions around the large water bodies.

Kampala lies next to Lake Victoria and being close to the equator gives it a more equatorial and monsoon type climate. The rainfall seasons which follow the equinoxes generally run from March to May and September to November. Uganda receives totals of approximately 2100mm a year of rainfall. The total average rainfall for Kampala is approximately 1350mm per annum.

The Kampala wind regime shows considerable variation across both the day and the year. The most frequent wind directions are the southerly and northerly winds which are generally calm. There is therefore a need to create environments that facilitate and or accelerate wind-flow to create better micro climates and evaporative cooling. This is especially in the outdoor spaces but there should also be good air flow within the living spaces.

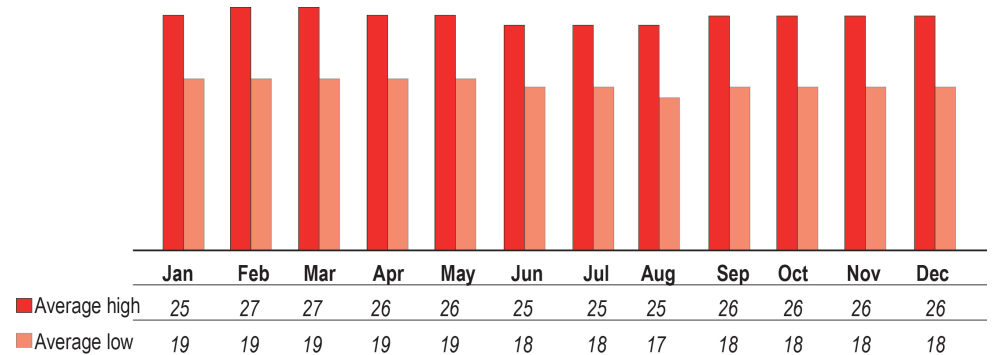
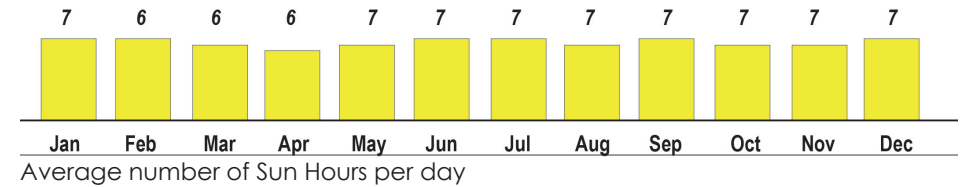
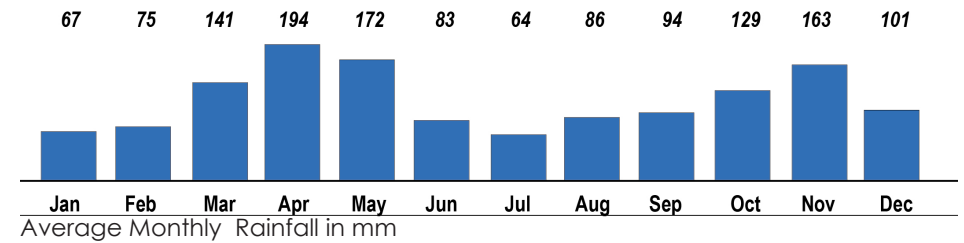
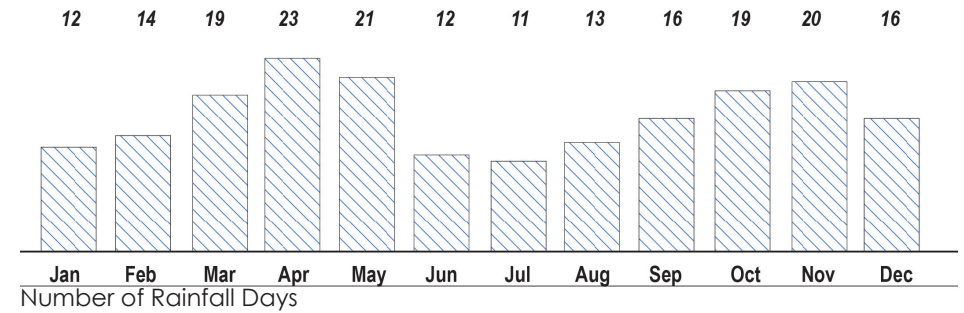
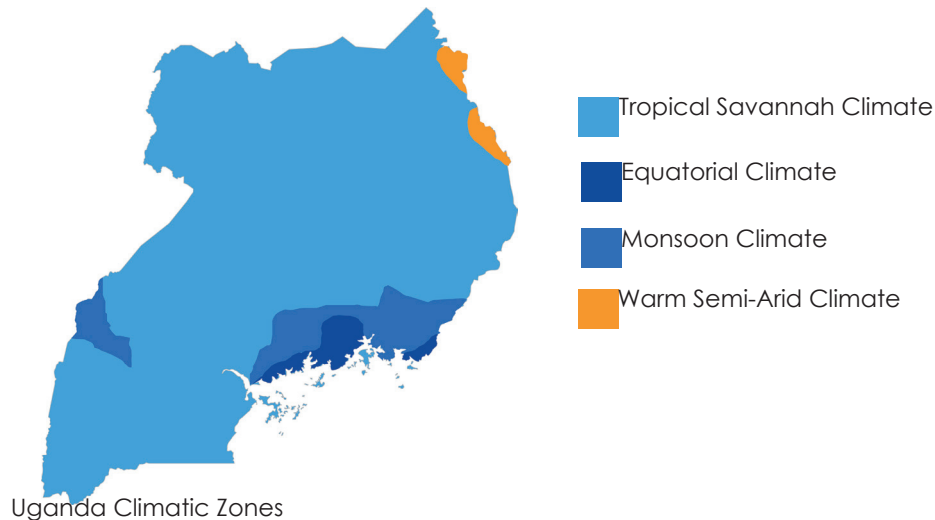

Average monthly temperature in Degrees Celsius

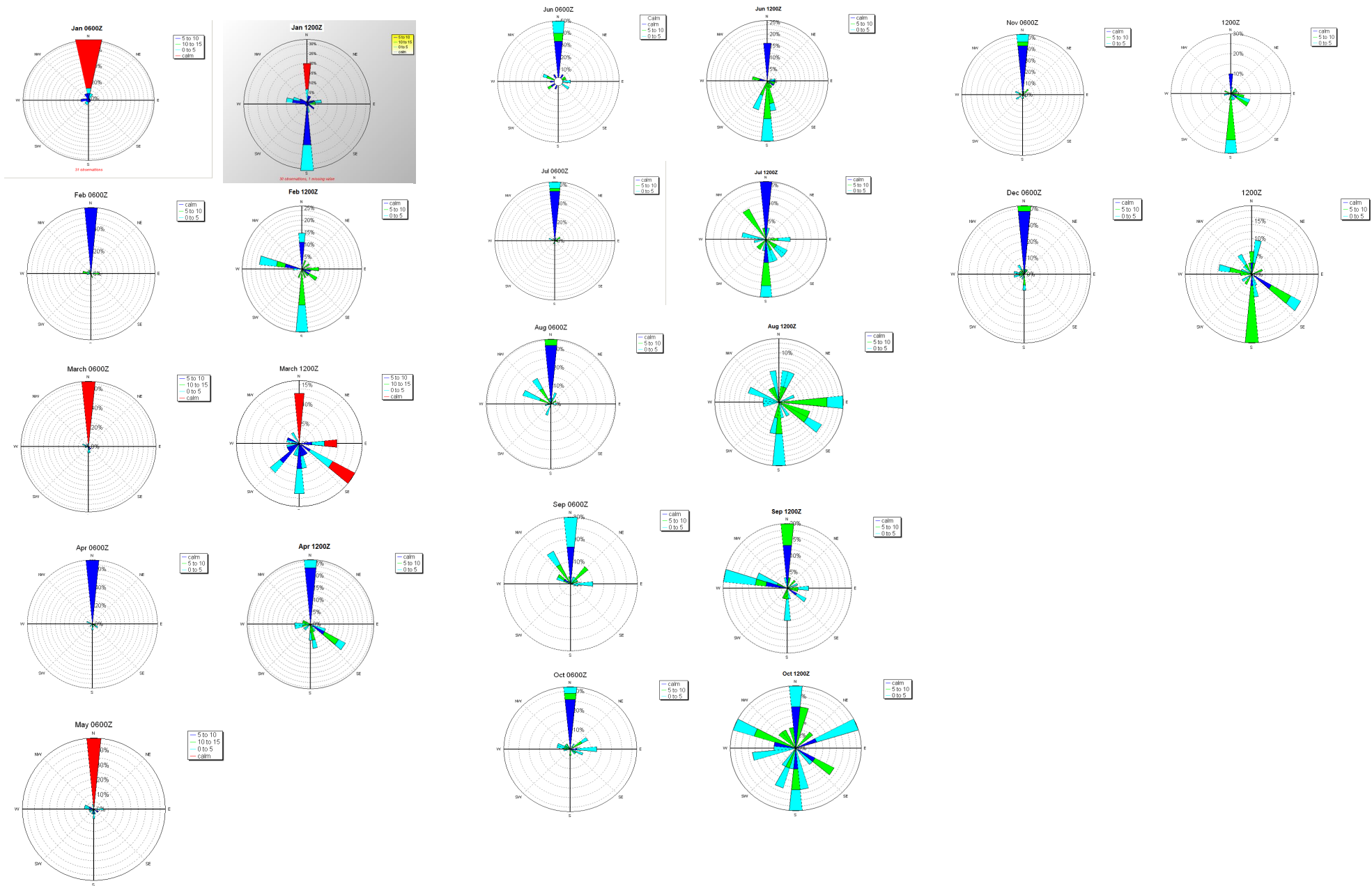

Wind Rose Data For Kampala

Source. Kampala Meteorological Department referenced in UNRA 2014

4. DEMOGRAPHICS AND GROWTH

According to the Kampala Physical development plan(2012), Kampala, currently has a population a little over 3 million. It is projected to grow to 5 million in the coming decade and to exceed 10 million within a generation. In relation,if in-migration is to accelerate over the coming generation the City's population may well significantly exceed 15 million, indeed approach 20 million, by 2040.

Currently the city is spreading out resulting into urban sprawl. This has resulted in the creation of slums,informal settlements and new developments on the city periphery and in the wetland zones. There is therefore a need for a new type of urbanism, a type of development that looks within, instead of developing outwards. This means the city develops and densifies from within, in terms of places for people to live. Living in this case entails sustainable transit systems, quality and inclusive accommodation, as well as places of employment and recreation.

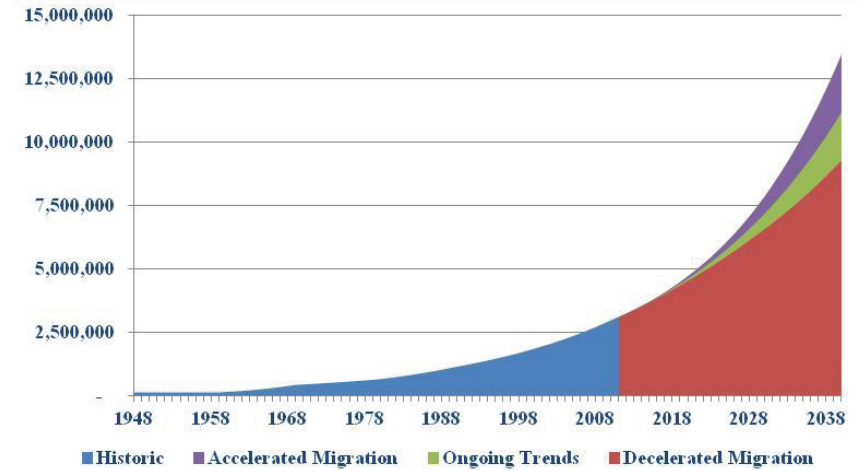

Kampala projected population growth

Source: Kampala Physical development Plan 2012

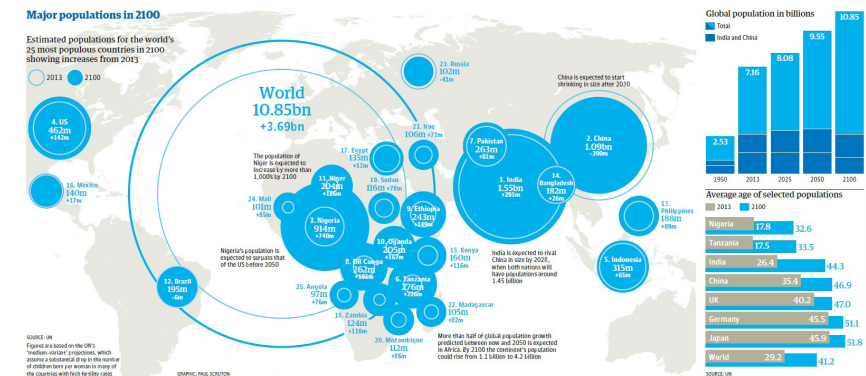

Major Global Populations 2100

Source: The Boom burst

Accessed at:http://profulgent29.rssing.com/chan-15548318/all_p4.html

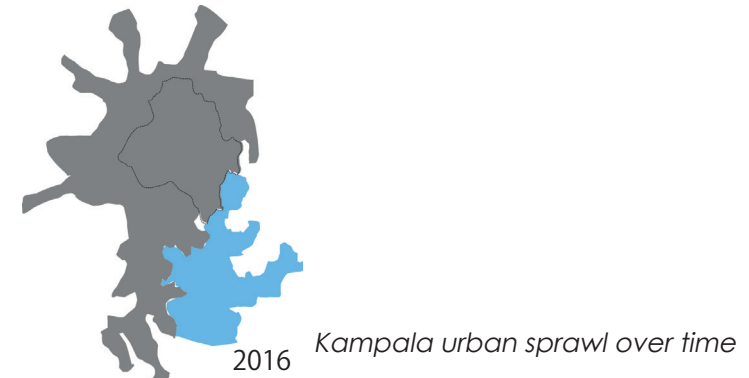
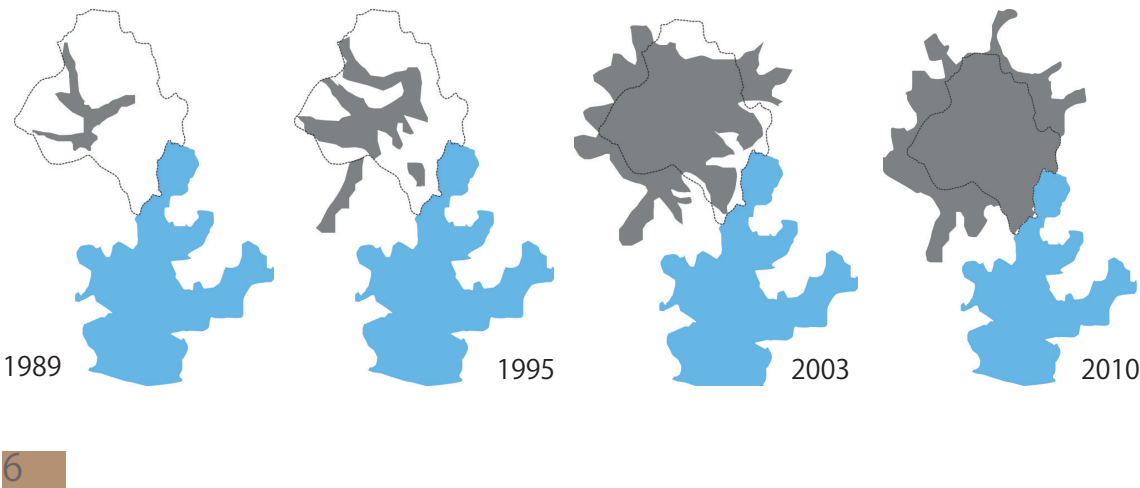

Kampala urban sprawl over time

5. THE CITY

5.1. FUNCTIONS AND LAND USE

Kampala city within the bounds Kampala City Council Authority is almost entirely built-up. According to KPDP(2012), the scale of open land reserves in Kampala today is very limited with vacant land comprising of less than 10% of the KCCA's landmass, with another 7% being wetlands. The bulk of the developed land is residential areas covering 60%. Employment associated landsmen stands at 10% while public services and facilities stands at 6%. With much of the KCCA already largely built-up, developments are restricted peri-urban areas that are within Kampala Metropolitan Trading Centres that lie between Kampala city and the neighbouring towns. It is important to look at inefficiently used areas already existent within the city for redevelopment. A case in point is underperforming industrial zones that have no place within the city.

It is estimated that Kampala city has a deficit of over 100,000 housing units. Kampala has recently seen new housing developments and estates mainly at the periphery of the city with varying concepts. Majority cater to the mid and higher income populace with the low cost housing projects being criticised for not being affordable.

The challenge is mainly on how to finance these projects especially those that cater to the urban poor. Some examples of how this can be done are seen from some examples below.

CHINA

Housing Provident Fund (HPF): With this programme, employers and employees pay a percentage (initially 5%) of the employee earnings into a housing saving fund which is then used by the employees to acquire low cost mortgages to purchase homes.

Cheap rental housing program(CRH): with this programme low-income groups can rent houses at controlled rent rates and access rent subsidies if they rent private houses and have access to further rent reduction if they live in public rental houses.

U.S.A.

Low-Income Housing Tax Credit Program (LIHTC): This programme offers tax credit to developers targeting low-income groups.

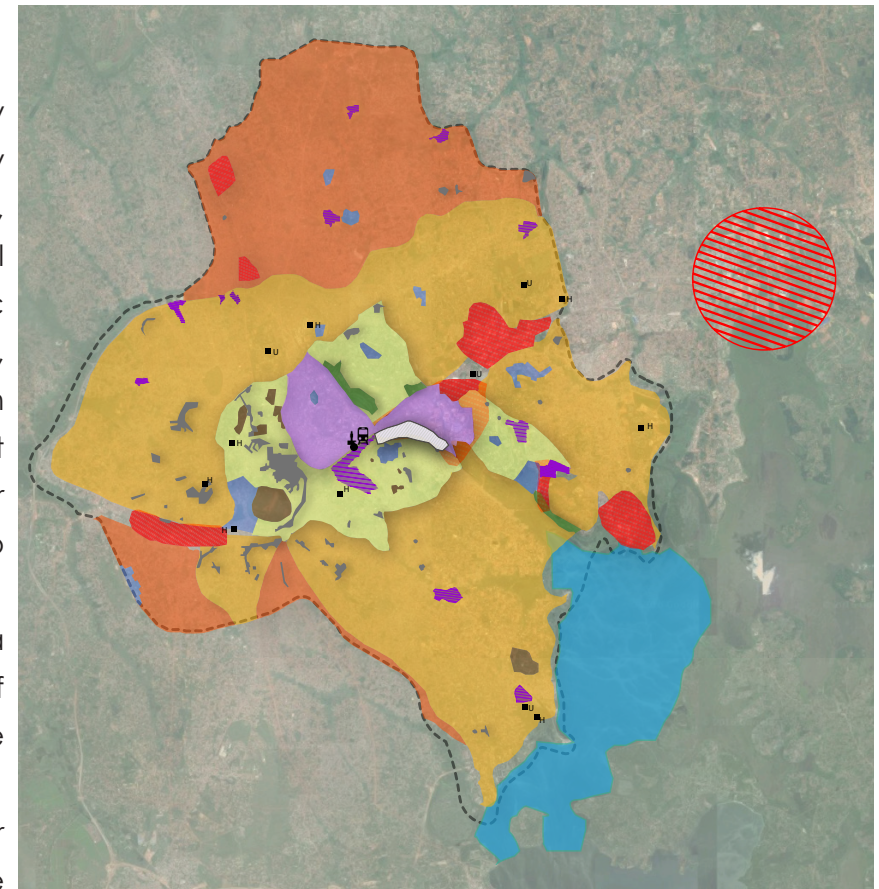

Kampala Major Land Use

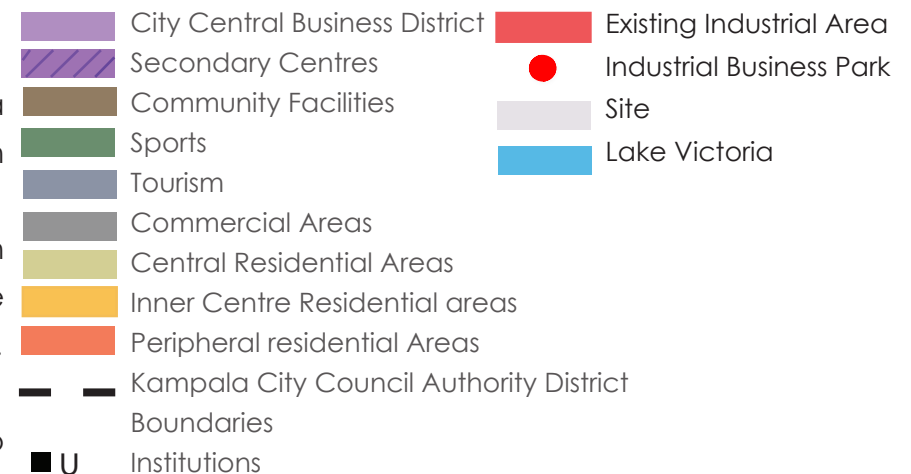

5.2. ECOLOGY

According to KPDP(2012), Kampala's ecosystem is defined by Lake Victoria and its catchment areas. Together with its location on the equatorial highlands, these have defined the region's climate and carved out its topography. The ecological framework includes a series of hills and undulating valleys with swamps and seasonal canals. Historically settlements were set up on the hill slopes with a social hierarchy that decreased as one went down the slopes thus those of a lower social hierarchy were relegated to the lower parts of the hills closer to the swamp valleys. Industries were also functionally zoned to these areas.

Over time, unplanned developments have mushroomed within the natural waterways blocking and polluting them. These areas being wetland reserved areas pose a significant challenge in regards to upgrading meaning these people would need to be relocated as the better ecological and financially feasible solution.

There is thus a need to provide an alternative area to resettle some of the residents in the most high risk zones, a move that would help restore the City's fragile ecological framework.

In relation, existing public green spaces in the city are few compared to the current population thus the need to develop new public spaces within the new proposal. It should be noted that Kampala's susceptibility to climate change especially flash floods presents an opportunity to develop green areas for flood water retention and infiltration creating a multifunctional green system.

Trees too play a very important role in the infiltration of rainwater. This because urban trees intercept large quantities of precipitation that buffers cities from flooding impacts. A high diversity of urban tree species directly contributes biodiversity as well. Conclusively, Urban greening will go a long way to give future city developments more biodiverse ,healthy and attractive ecological networks.

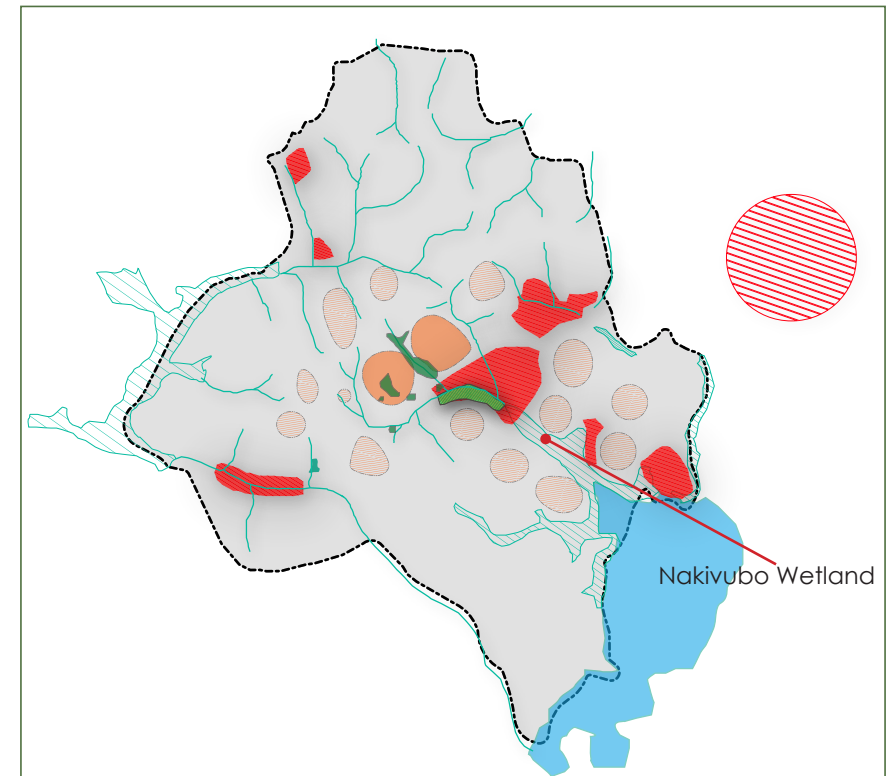

Kampala Drainage System and location of industrial areas in the flood plains



5.3. CONNECTIONS

With regards to population increase, comes the need for a more efficient transit system since transport is a major driver of urban development and a good transit system is key to sustainable urban development.

Uganda today has a multi-modal transport system, by means of road, air, rail and water. According to Van der Griend and Siemonsma(2011) Road transport is predicted to remain the dominant form of transport, carrying over 95% of country's goods traffic and 99% of passenger traffic. Road traffic has continued to grow rapidly in recent years especially in the Greater Kampala Metropolitan Area (GKMA). The current national vehicle population is estimated at 635,656 vehicles, with a potential growth of more than 10% per annum. Half of these vehicles are located in the city or use the city roads daily. Commercial passenger and goods transport by road is exclusively performed by the private sector (MoWT, 2010) cited in Van der Griend and Siemonsma(2011) . Public transport in Uganda is mainly operated by buses and other forms of motorised road transport i.e. commuter minibuses and motorcycles. Many rail lines were closed due to technical deficiencies and inadequate traffic volumes, though currently they have been restarted and are in their early redevelopment stages.

Pedestrian and bicycle transit is greatly neglected with poor walking spaces and no design for dedicated bicycle lanes on the city's transit network.

Positively, Kampala city is in the early stages of developing a rapid transit bus system and has also restarted the train transit system as seen in Fig.16. In the future, the city has proposed a light rail system in a bid to de-congest the city traffic. This presents an opportunity to extend this light rail system to the site area to create a better connection to the city. This system could also link the other areas that have potential to be redeveloped.

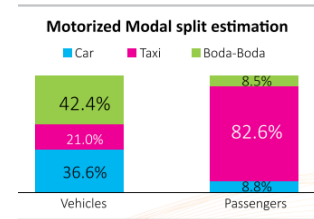

Fig.16 Kampala Transport by mode of travel

Source: KCCA, 2014

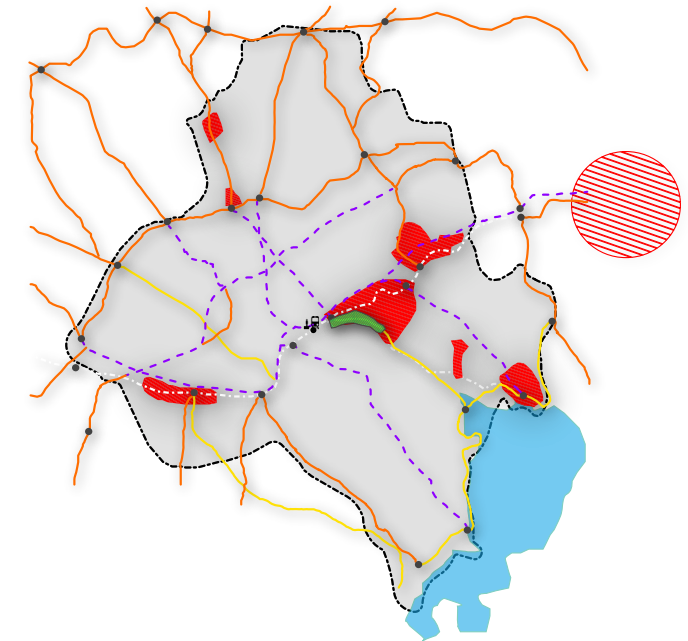
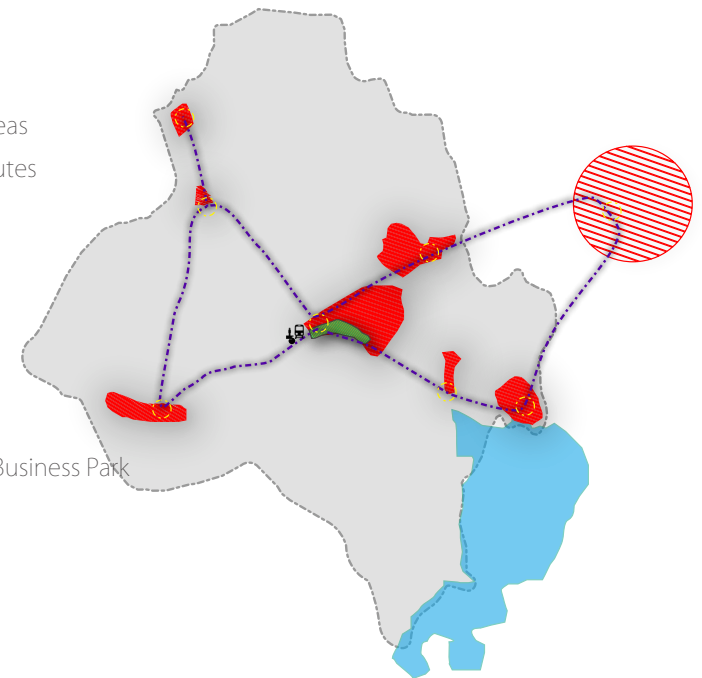
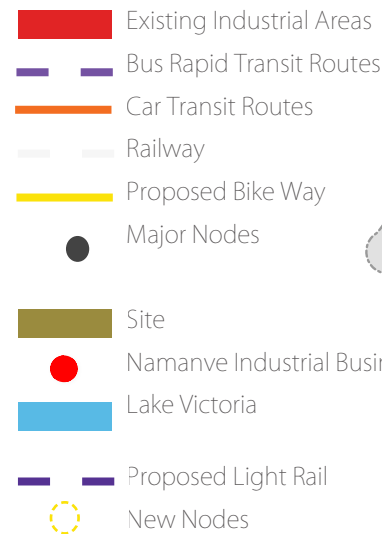

Fig.16 Kampala Transit Connections



Proposed New Connection

6. RESEARCH SUMMARY

6.1. Summary of Challenges

First, Kampala is facing a problem of uncontrolled sprawl coupled with limited vacant land within the city. The two together create a bit of an impasse in terms of the need to develop vs the inevitability of spreading to where land is available. A strategy to redevelop inefficiently functional areas within the city can help alleviate this impasse. For this thesis I choose Industrial zones. The reasoning behind this shall be explained fully in the next chapter.

Secondly, the congestion in the city's transit system that is entirely car dominated requires a shift to a more sustainable transit module.

Lastly, the challenge presented by Climate change needs to be taken into consideration and adopt principles that can work around and alleviate these challenges in the design proposal.

In conclusion, the research shows that there is a need for strategic and holistic development to allow for a multifunctional area catering for employment, housing, good transit and better public spaces. The development should be envisioned as a new urbanism that is more socially cohesive and adaptive to people's way of life and future changes.

6.2. RESEARCH QUESTIONS

1. Can we develop our communities in a way that adapts to the threat of climate change?
2. Can this adaptation be done in such a way as to create more sustainable communities in terms of social, ecological and economic sustainability?

6.3. GOAL

Reinventing the Kampala industrial Area as a resilient and adaptive sustainable urban-scape.

This is to be achieved by using 5 resilience principles and adopting them as objectives of the design proposal.

Resilience can be defined as the ability of a system to absorb disturbance and still retain its basic function and structure. (Walker and Salt 2006, cited in Ahern (2013)).

6.4. Objectives and General strategy



Increase bio diversity: This is aimed to support ecosystem processes and services. This includes flood resilience, food production and recreation culminating in the creation of a more attractive and healthy environment.



Build Urban ecological friendly networks and connections: Connectivity in terms of transport services that serve both the population and that are environmentally responsive. In this particular case, the urban connections are in relation to hydrology, transportation and urban mobility with a larger contribution to building resilience capacity.



Design for Multi-functionality: With the key aim of the project being the development of existing areas within the city, efficient use of this space is imperative. This is to be achieved through the combination of spaces to achieve multi-functionality. The functions can be organised in such a way as to work independently or in complement with each other within a defined space and at varying scales.

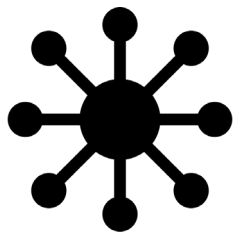

Allow for redundancy and use of modular systems design: This is true for the storm water system on site using decentralised elements that allow for failure without letting this affect the entire system.



Adaptive Design: The design should focus on and respond to its location in terms of geophysical, social, economic and political contexts. The urban plan also allows for flexibility by developing the site in phases and allowing for changes in the future.

7. THE DESIGN PROJECT

7.1. SITE SELECTION CRITERIA

Since the focus of this thesis is to create new developments without the negative effect of sprawl, I chose to look at potential sites within the city. This in reference to the principle of redundancy and modularization as mentioned being one of the five base principles I shall be following. The City of Kampala being a colonial city was developed under rigid segregation of both functions and people a segregation that is still evident today. The segregation of function left areas designated for industry to grow redundant over time as a result of economic slow down. These areas can be seen as redundant since they perform below par. As a site for this thesis project I chose the existing central Kampala industrial area. Below are the reasons for this choice.

- First, with the development of an industrial park outside the city, it is inevitable that larger scale industries shall move out as it is both logistically and financially sustainable for them to do so. This in itself presents an opportunity to use an already existing resource to combat future urban problems like land shortage and adaptively reuse this area as an extension of the city albeit playing a more multi-functional role.
- Secondly, location in a wetland area. Historically, industrial areas in Uganda have been located in wetland areas mainly due to the ease of access to water and the ease of disposal of waste material into the natural filters. The other reason would be logistical in terms of the railway line that was constructed following the lowland areas of Kampala. The ease of creating flat landscapes in a hilly region was presented in these low lying marshlands that were easily drained and reclaimed, a cheaper alternative to cutting and reinforcing the hilly landscape. The location in low lying area provides an opportunity to develop a new type of urbanism in a climate change vulnerable area that is already in existence.

- Thirdly, the site presents though degraded, an infrastructure that can be built upon both in terms of water management and connectivity at both neighbourhood and city scale.

- Lastly, the Kampala central industrial area in itself is a major employment centre encompassing both informal and formal sectors, large-scale and small scale industries as well proximity to both low scale and higher end accommodation settlements. The site presents a unique palette of social cohesion that provides a unique sense of place that can be tapped into to develop a more robust and dynamic community that functions independently in itself but is also part of the greater whole that is the city of Kampala

7.2. THE SITE

The project site sits within the Kampala industrial area. This particular zone of the industrial area is the most low lying area and would be greatest affected by flash floods and water from the surrounding hills.

This site also sits adjacent to Nakivubo wetland, a natural filter for Lake Victoria and an existing waste water treatment plant that is in the future to be moved south into the wetland area.

The Site is traversed by two rail way lines only one of which is still being used. This provides an opportunity to create a well serviced place in the proposed area.

Water from the city is transported through the nakivubo channel that runs through the site creating an opportunity to re-invent this channel, the attitude towards it and how it is used.

The general infrastructure in the area is mainly industrial, commercial and very few residential areas creating an opportunity to develop more public space and accommodation area for the envisioned population increase.

The green strips also have the potential to be redeveloped into infiltration areas and public space.

KAMPALA INDUSTRIAL AREA

Size -2.55km²
 Pop (2011) - 3672
 2050 - 8842

Employment (2011) - 13965
 2050 - 18888

Built Up Area - 138295m²
 2050 - 264342m²

PROJECT SITE

Size - 0.65km²
 Pop (2050) - 2210.5
 Employment - 4722
 Built up (Current) - 174,955m²

Unbuilt - (Hard scape) - Roads -57976m²
 - Other - 168,963m²
 - Soft scape - 245467m²

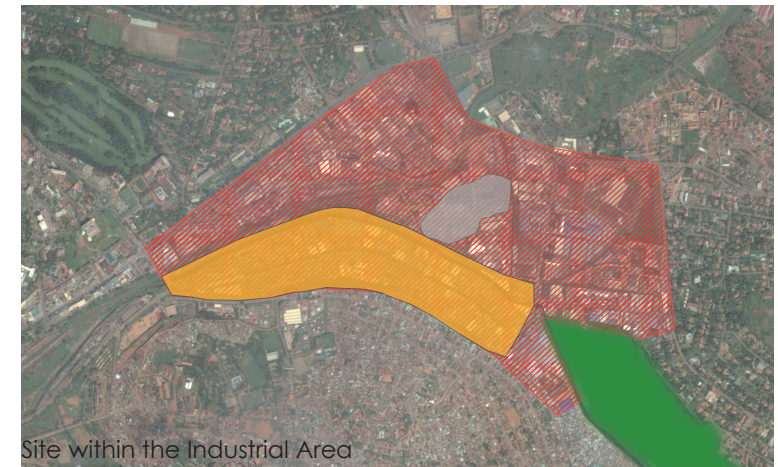

Site within the Industrial Area

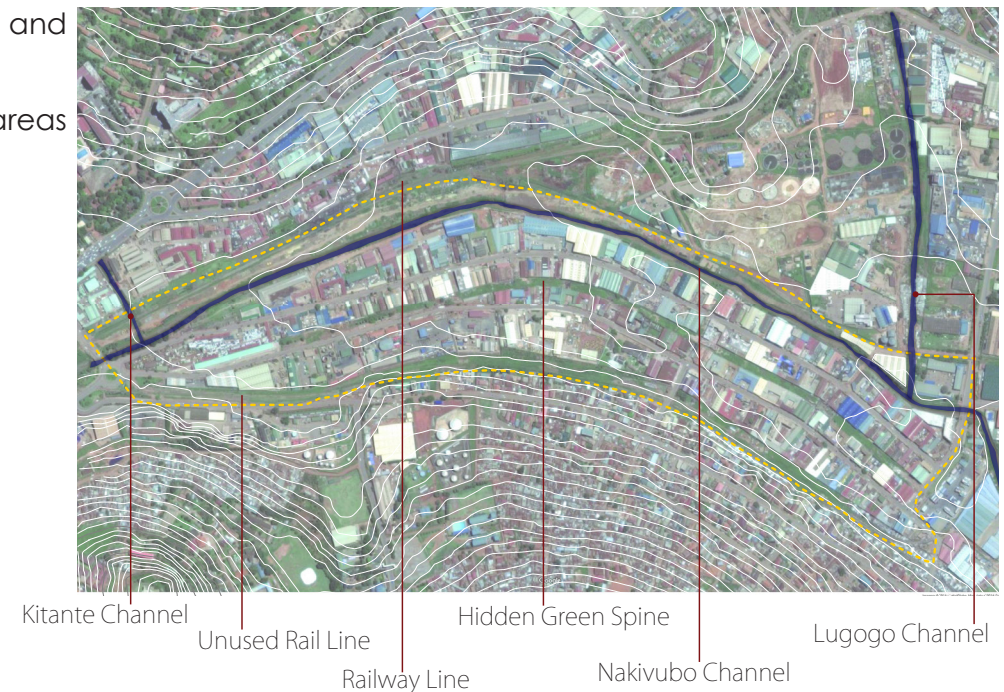

Key Features in the site Area

7.2.1. SITE CHARACTERISTICS

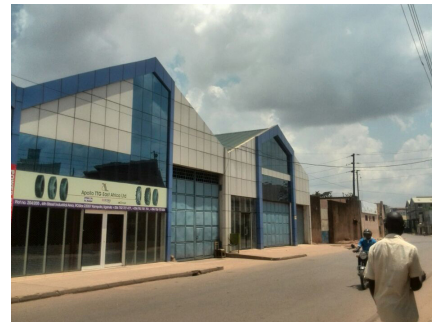

7.2.2. EXISTING FUNCTIONS

The site is characterised by industrial functions that are complimented by office and commercial areas. The main commercial functions are large scale whole sale especially of bulk construction products and automobile showrooms and repair shops. There are some new developments that cater to office function but these are mainly bank branches that are the more significant developments. A few office buildings have been constructed as well.

There is however a general lack of cohesion of functions which also do not cater to the needs of the greater population.

It should be noted that there is a general lack of public space with the majority of the open spaces being with closed courtyards.

The new development strategy for this area's, functions envision them to be mixed, cohesive, evenly distributed and catering to the everyday needs of the local population.

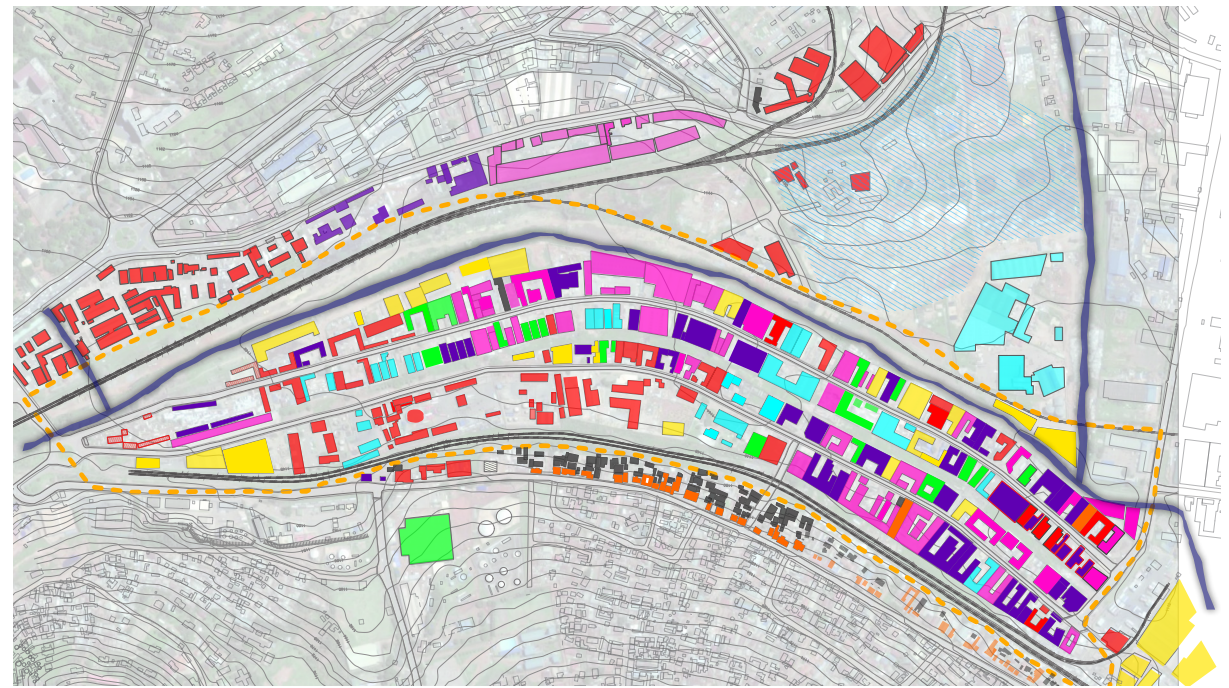

	Residential
	Office
	Commercial whole sale
	Mixed office and Industrial
	Industrial (Manufacturing)
	Industrial(manufacturing) and Commercial
	Industrial (warehousing)
	Government storage
	Community Centre
	Current waste water treatment plant

7.2.3. EXISTING CONNECTIONS

The site has to mainly car dominated connections that cut across it east to west. The site is generally lacking in the north south connectivity which would give it better permeability and also better connection to the areas around it.

The main car streets are to be narrowed into single lane streets that create a public bust transit loop around the site.

The new connections can also serve to transport and retain the storm water generated on the site as well as that which arrives from the surrounding areas.

A new public transit system is to be introduced while discouraging private car use. Other sustainable means of transit like walking and cycling are to be greatly supported in the new proposal through the creation of pedestrian friendly streets and walkable neighbourhoods.

In addition, consideration needs to be taken in creating a hierarchy within the new connections that are proposed with the transition elements becoming more of public spaces and creators of opportunity for interaction with both the landscape and the users.

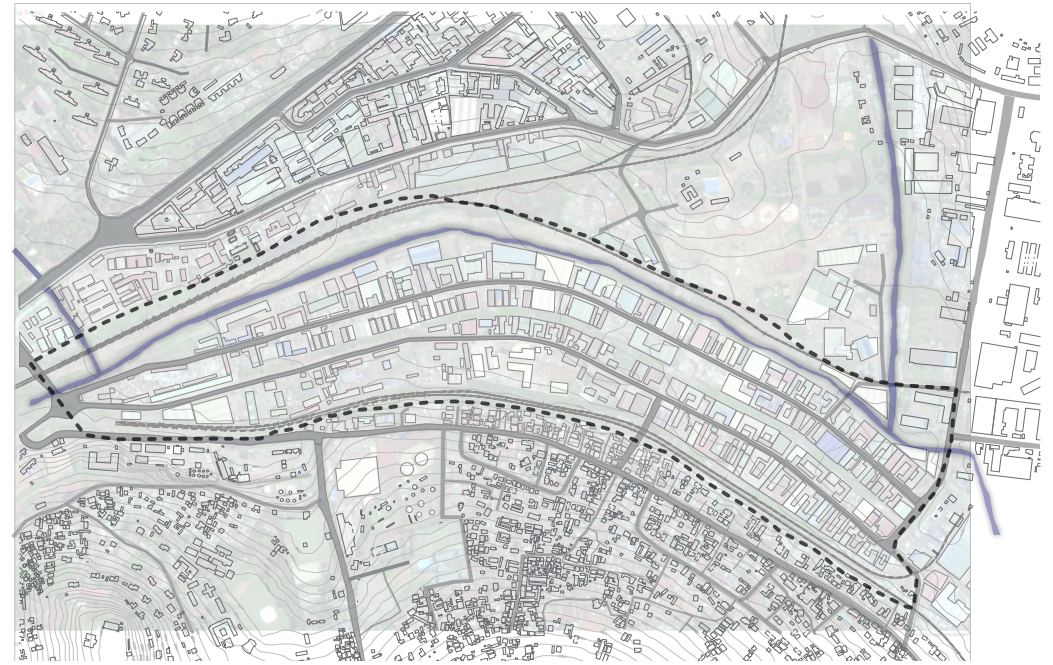

Existing Site Connections

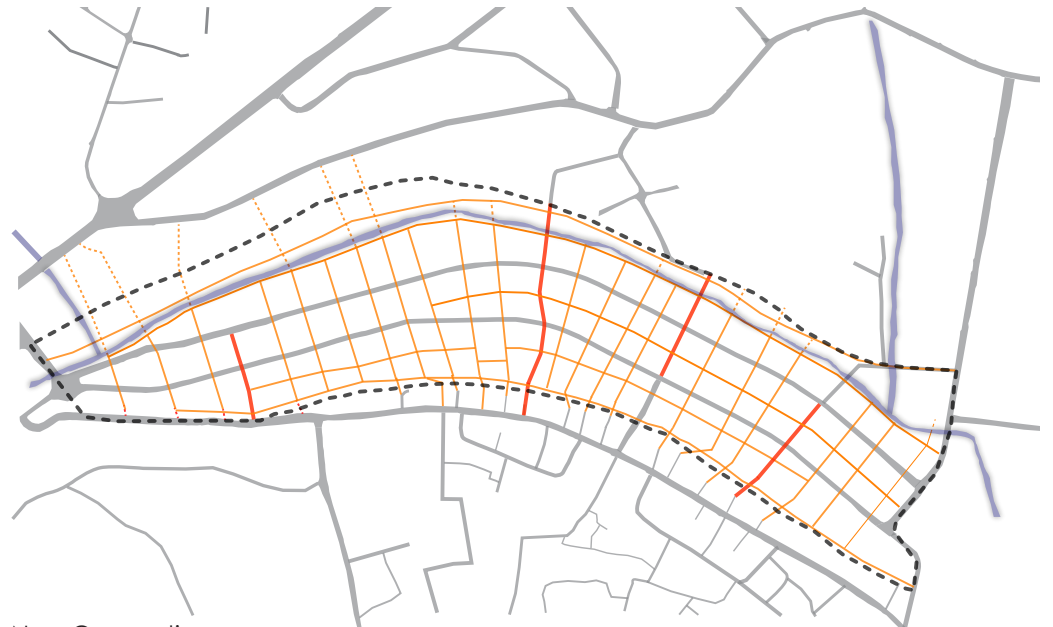

New Connections

-  Allow for regular car traffic
-  Pedestrian and bicycle dominated streets that can accommodate service and emergency vehicles

7.2.4. SITE CLIMATE ANALYSIS

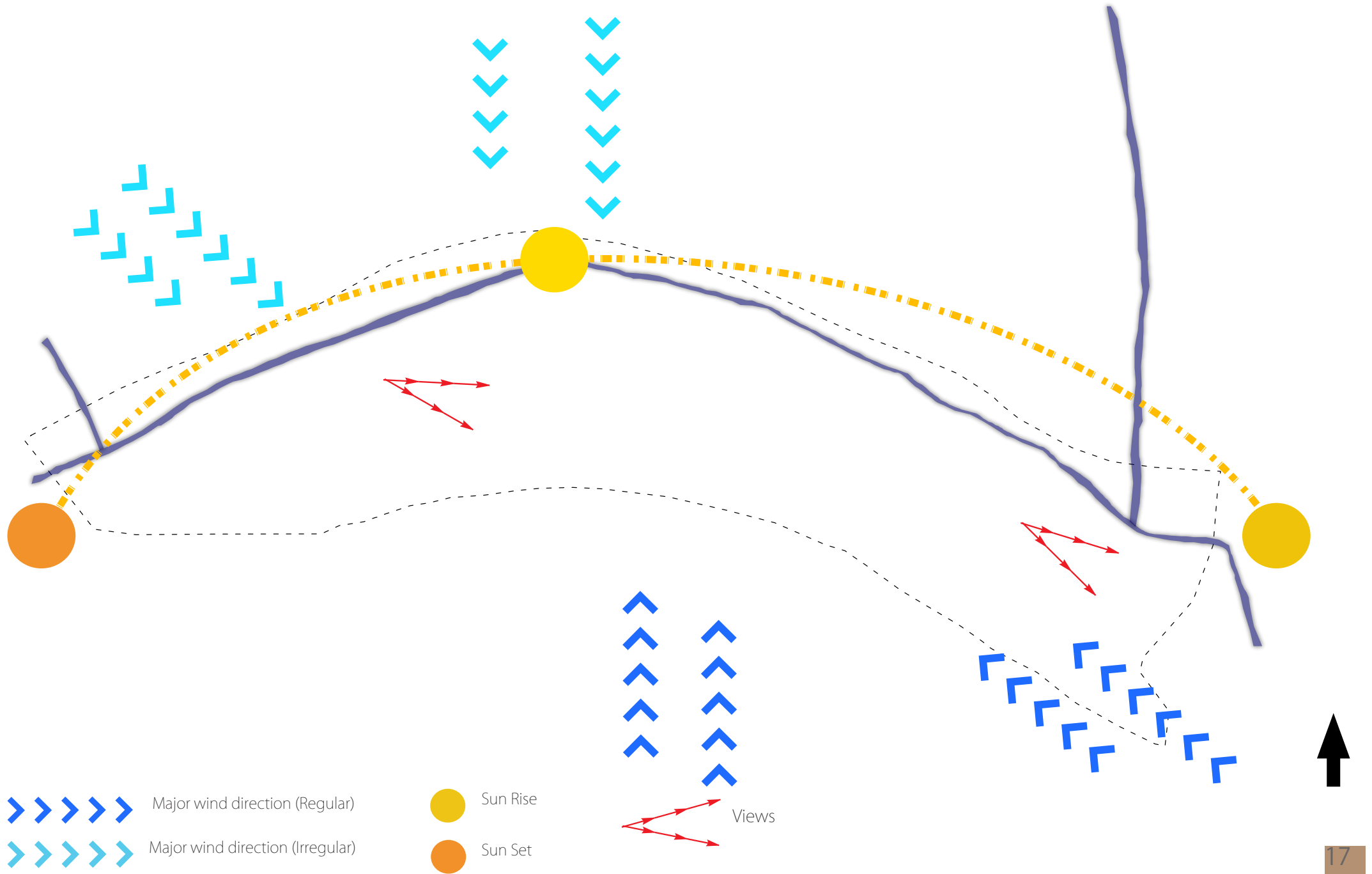

7.2.5. SITE STORM WATER ANALYSIS

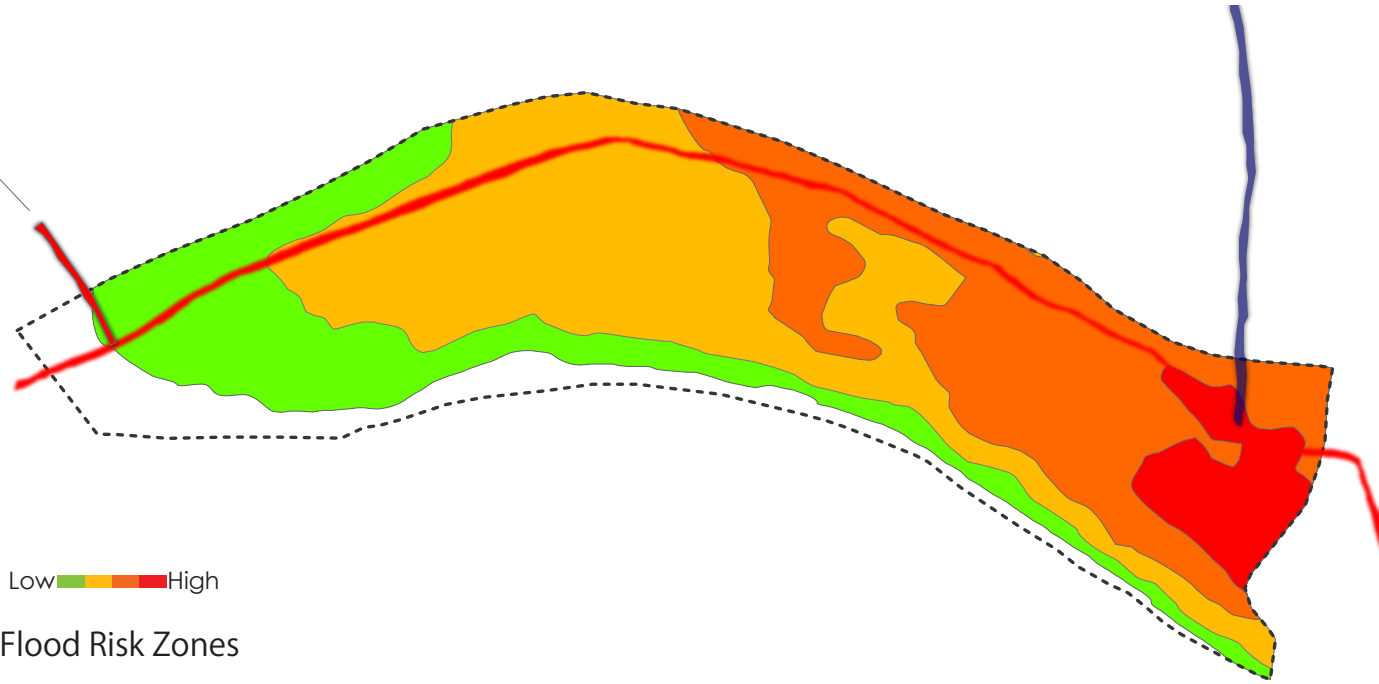

- Complete Redevelopment
- Infill Redevelopment
- Street Redevelopment

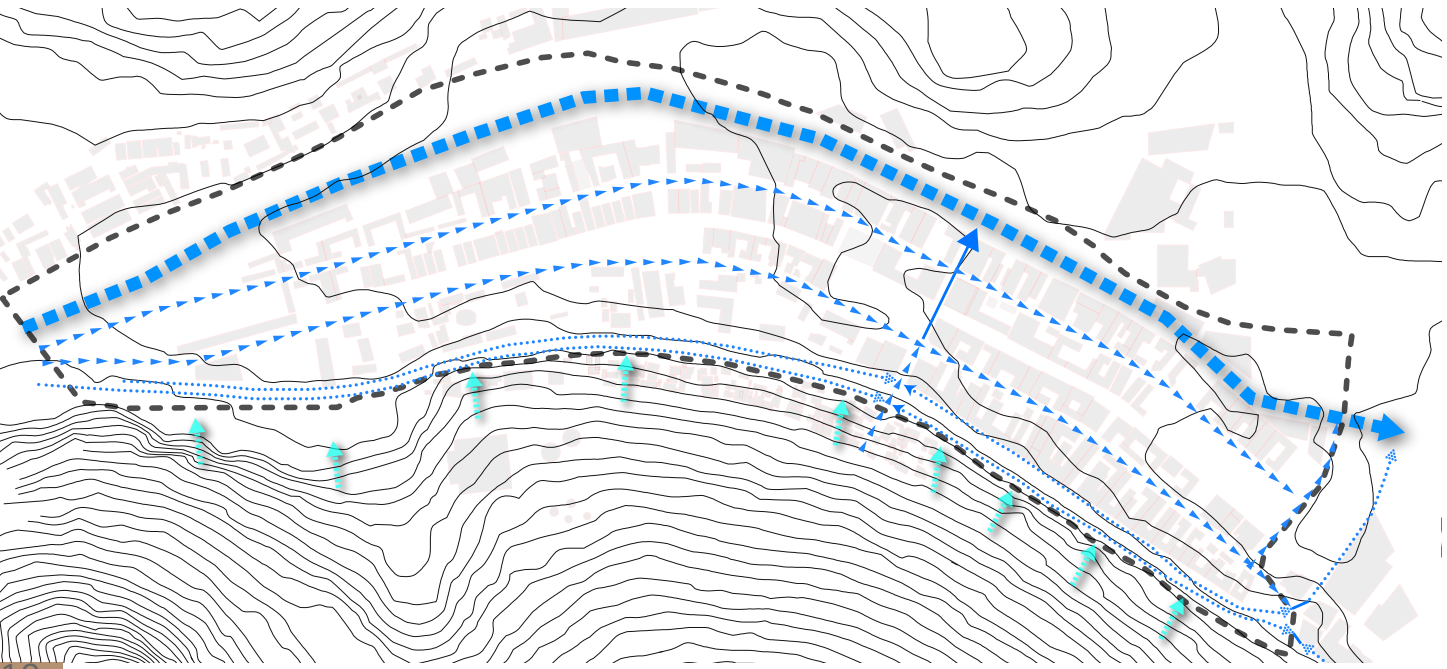

- Current Water Runoff Flow**
- Canal (water from City)
 - Street flow with subsurface drainage
 - Subsurface drain
 - Surface flow Direction
 - Open Drainage Trench

The site can be looked at wholly as a flood plain and has a flood risk in its entirety. The general slope in the site albeit small makes some areas of higher risk than others but provides an opportunity for gravity driven flood alleviation strategies through retention and infiltration. There exist both hard scape and green scape in an almost equal measure on the site. The character of the soft scape areas is they are more of leftover space from the rail lines and the Nakivubo drainage channel, meaning that there is very little infiltration on the site in the built up areas.

Unbuilt - (Hard scape) - Roads -57976m²
 - Other - 168,963m²

- Soft scape - 245467m²
 - Roofs - 173,955m²

Water Runoff currently generated on site.

Values considered

Average Maximum Rainfall intensity recorded - 70mm/hr.

Max rainfall depth - 66.2mm

Return period - 2years

Duration 2hrs

Clay loam soil infiltration rate - 6.3mm/hr.

Evaporation Rate 4.65mm/day

Area	Size m ²	Runoff Coefficient	Total runoff m ³ /hr
Hard scape	168963	0.7	118274.1
Roads	57967	0.85	49271.95
Roofs	173955	0.8	139164
Soft scape	245467	1.5	25774.04
			332484

332484x 2hrs = 664,968m³

This is the amount of runoff volume produced by the site before intervention.

The project thus will reduce the amount of runoff produced on the site by creating more green areas to allow more infiltration, reduce the area of paved surfaces and collect roof water runoff.

8. THE DESIGN PROPOSAL

8.1. SITE DEVELOPMENT PHASING STRATEGY

The overall site development site will be developed in phases to allow for adaptability in future developments.

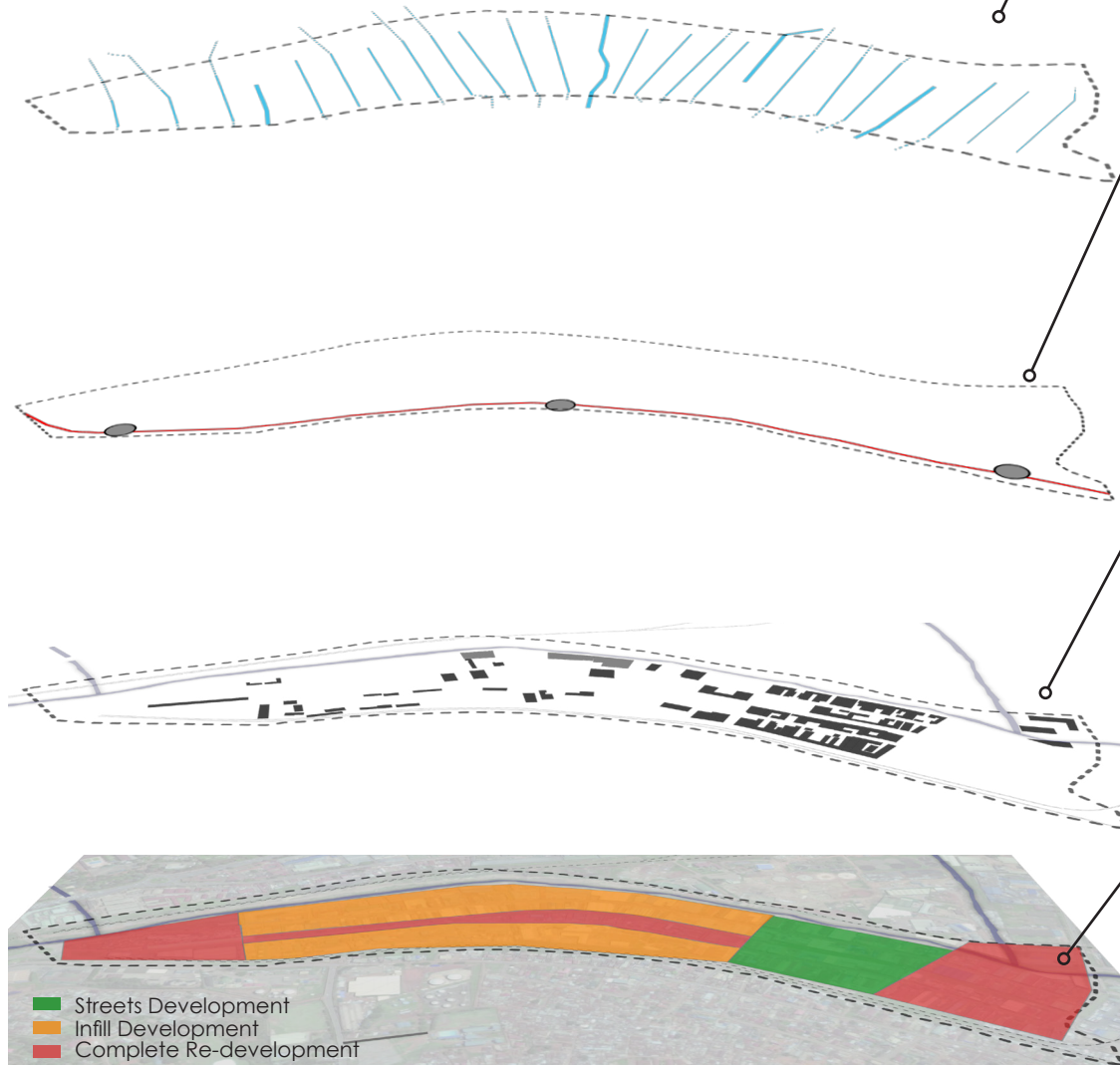

Wind Corridors as pedestrian priority streets

The site being in a tropical equatorial climate, has a need to allow and facilitate wind-flows. The dominant winds on site are mainly northerly and southerly winds. The new streets are thus oriented to allow for both human and natural elements movement through the site. This orientation also allows for the continuity of the missing north-south physical connection

A new Sustainable Mass transit system

Using the existing framework of the defunct rail to the south of the site, a new elevated light rail linking to the proposed city light rail system is to be developed. This shall be the initial trigger for developing the site by easing movement within the site and to the surrounding areas through public transport.

Buildings to be retained

Majority of the buildings on the site are old and derelict. However, some are in good condition, can be kept and integrated within the new urban fabric forming a unique layer that speaks for the old and the history/heritage of the site.

Site Development Zones

The proposal will have some areas that will be completely redeveloped, areas where infill developments will take place as well as areas where minimal intervention will take place. These minimal interventions will mainly involve the creation of new pedestrian streets to allow for permeability but in all to try and maintain a piece of the old with a few adjustments.

Completion

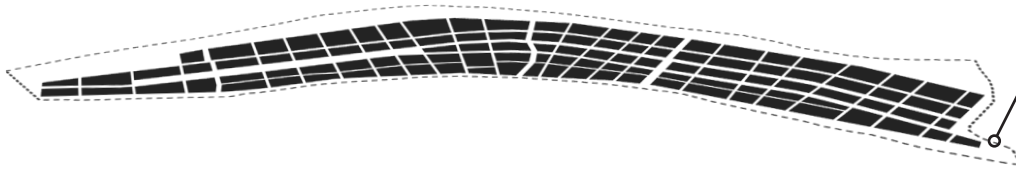

The final completion of the entire site would have seen various evolutions of the site allowing for adaptability. This evolution happens within the blocks allowing them to evolve and vary in terms of structural development and function but all in the while keeping the initial structure of the streets and that define the overall pattern

PHASE III

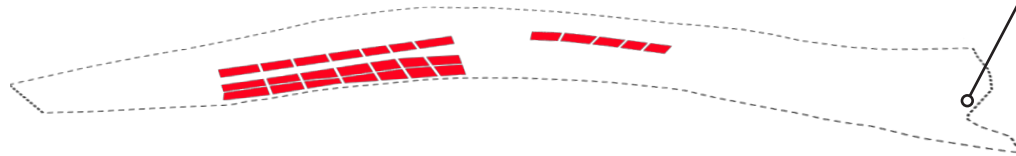

The final phase in a period of 40-50 years would see an infill densification within the already marked boundaries of phase two. This would also allow for development of some areas that would have been left over in phase one but are at the moment too old or derelict.

PHASE II

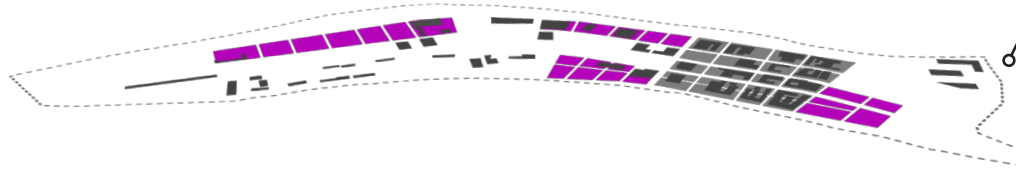

This phase is to occur in the next 20-30 years. It would entail the development of the area along the edges of the site to tie the developments together marking its extents and unifying along the site edges. The edges along the water can also be developed based on newer climate change predictions at the time. The new streets can also be gradually added in the old section of the development area.

PHASE I

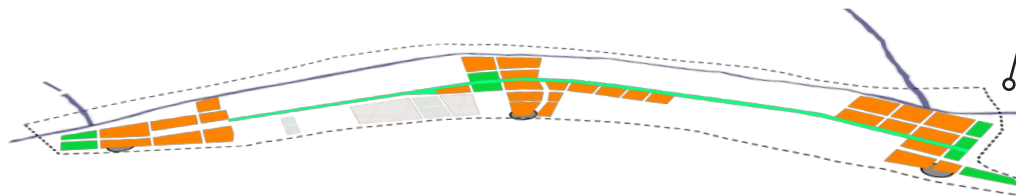

The first phase of the site can begin in the next 10-15 years and see full completion in the next 20 years. This time-line would allow for a more detailed study of predicted changes in climate and also allow for relocation of those in the affected zones. This is the phase covered in this thesis and kick-starts the site development with an urban acupuncture type development. The developments are tied together by a transit oriented development i.e. mass sustainable transit to the south, pedestrian and seasonal water transit at the centre and regular transit of water to the north .

8.2 SITE DEVELOPMENT FOR PHASE 1

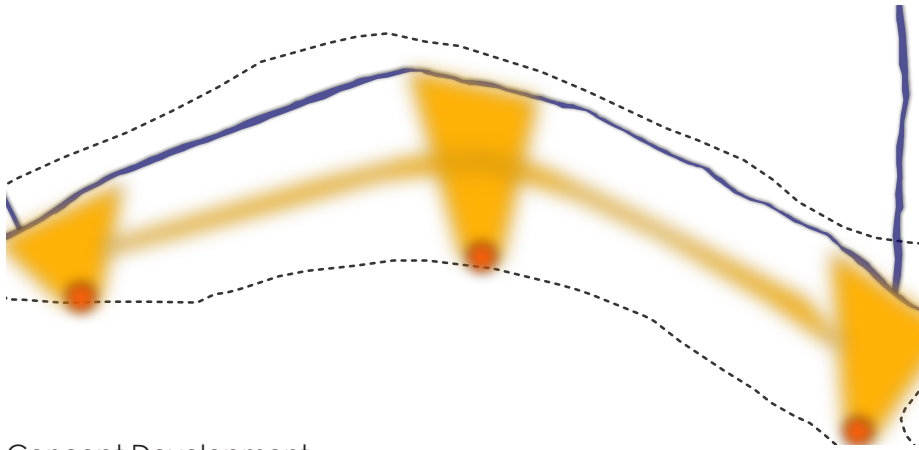

Concept Development

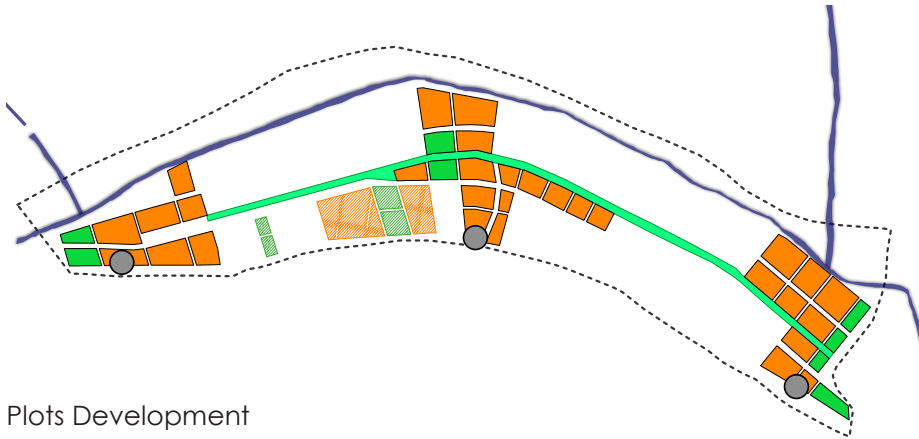

Plots Development

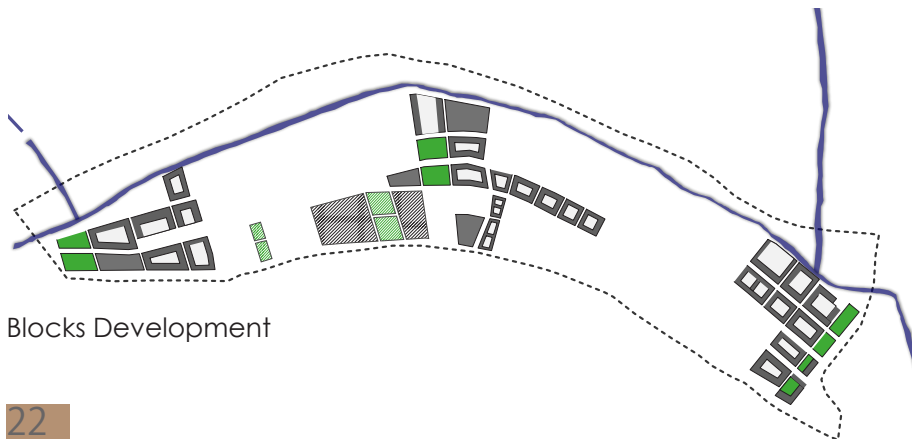

Blocks Development

The site development is influenced by an acupuncture strategy that is guided by a transit oriented development. The development starts at the nodes which are light rail stations and progress inwards towards the Nakivubo water Canal. The three acupuncture points are tied together by the site water intervention strip that is an existing unused green strip which is re-purposed into bio Swale and pedestrian street.

The blocks are developed in line with the northerly oriented new pedestrian priority streets. The blocks are varied in size to cater to different sized developments. The sizes are however not larger than 75m to make them walkable and pedestrian friendly. The blocks include public space blocks and infill development blocks as well.

The blocks are further developed to allow for public a semi public spaces within the individual blocks

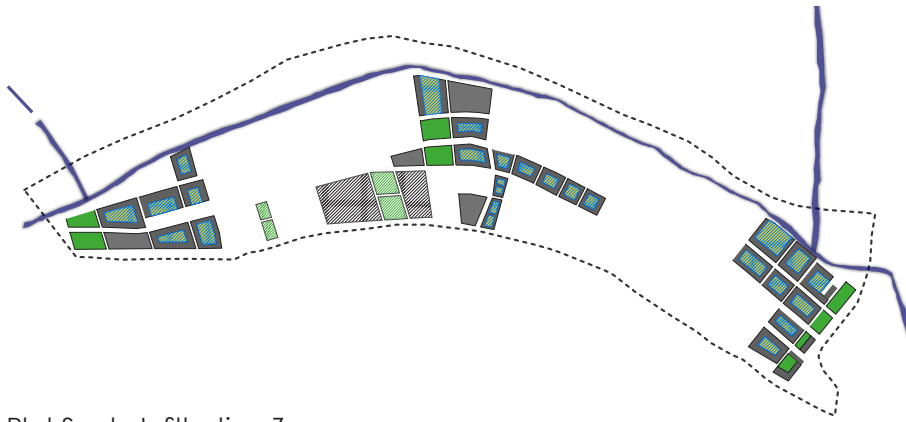

Plot Scale Infiltration Zones

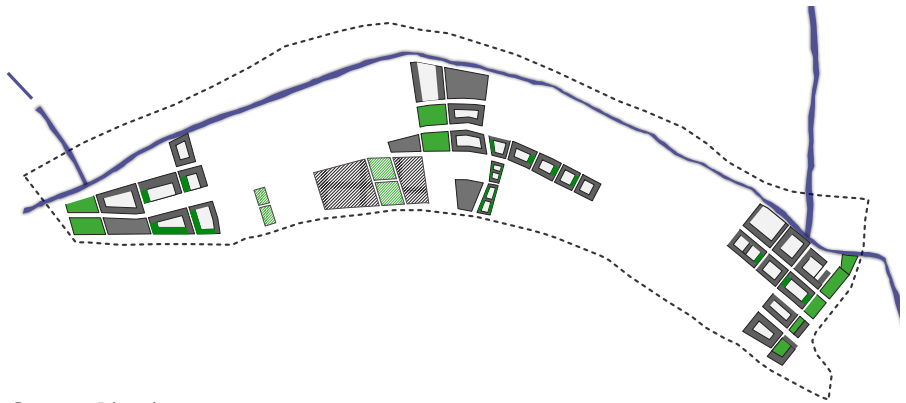

Green Blocks

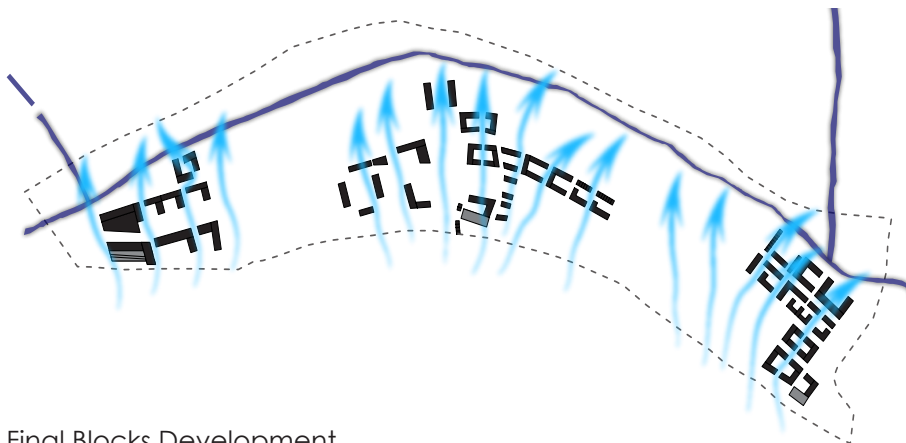

Final Blocks Development

The spaces developed become activity places where people come together.

The spaces also become water retention and infiltration spaces localised to the neighbourhood level.

The Developed blocks are further opened up on the edges to allow for biodiversity to be inserted into the building structure. This is mainly to allow for privacy between the developments while maintaining the size of the narrow streets. The new biodiversity blocks consists of trees and other vegetation types.

The blocks are further subdivided to allow for air, water and easier pedestrian movement and access.

Varying the heights of the buildings also helps facilitate air movement between the buildings.

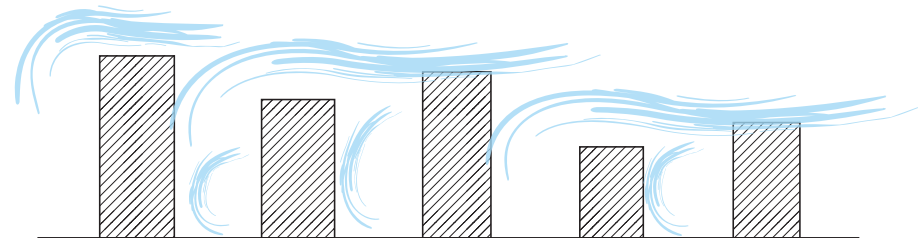

8.3 FLOOD MITIGATION STRATEGY

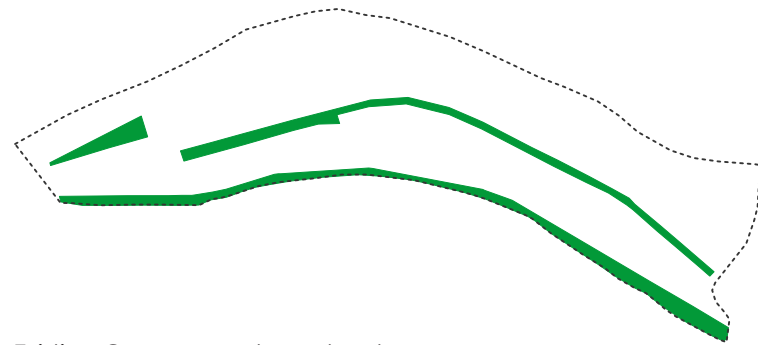

Existing Green areas to re-develop

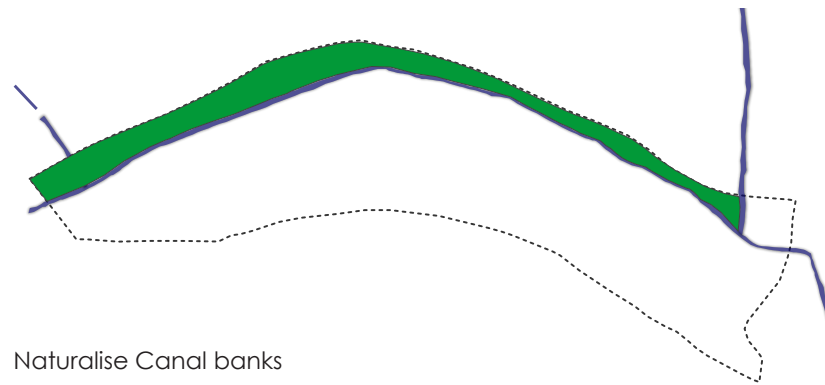

Naturalise Canal banks



Storm Water Consolidation Strategy

- Blue arrow: Canal(water from City)
- Light blue square: Areas for site storm water Management
- Red dashed arrow: New Flow

Instead of redirecting the water runoff on the site to the Nakivubo canal that is already loaded at rainfall peak times, the proposal will use existing left over spaces as retention and infiltration zones. Excess water can then be discharged to the Nakivubo Canal at strategic points if need arises. The on-site infiltration system can also work in reverse in case the existing canal overflows and take on some of the excess water and letting it rejoin the canal further downstream closer to the Nakivubo Swamp. The left over green spaces can also be re-developed, restructured and re-purposed into new functions that support and add life and variety to the new development. This includes edible landscaping, urban forestry, floriculture and ornamental landscaping. The site has pedestrian unfriendly streets with underground water drainage. The strategy is to reduce the impermeable surface and daylight the streets bring runoff flow to the surface and infiltrate in the street green. The project reduces the impermeable street area by almost 70% making the streets one way streets looping and allowing for public transport.

8.3.1. Urban Greening

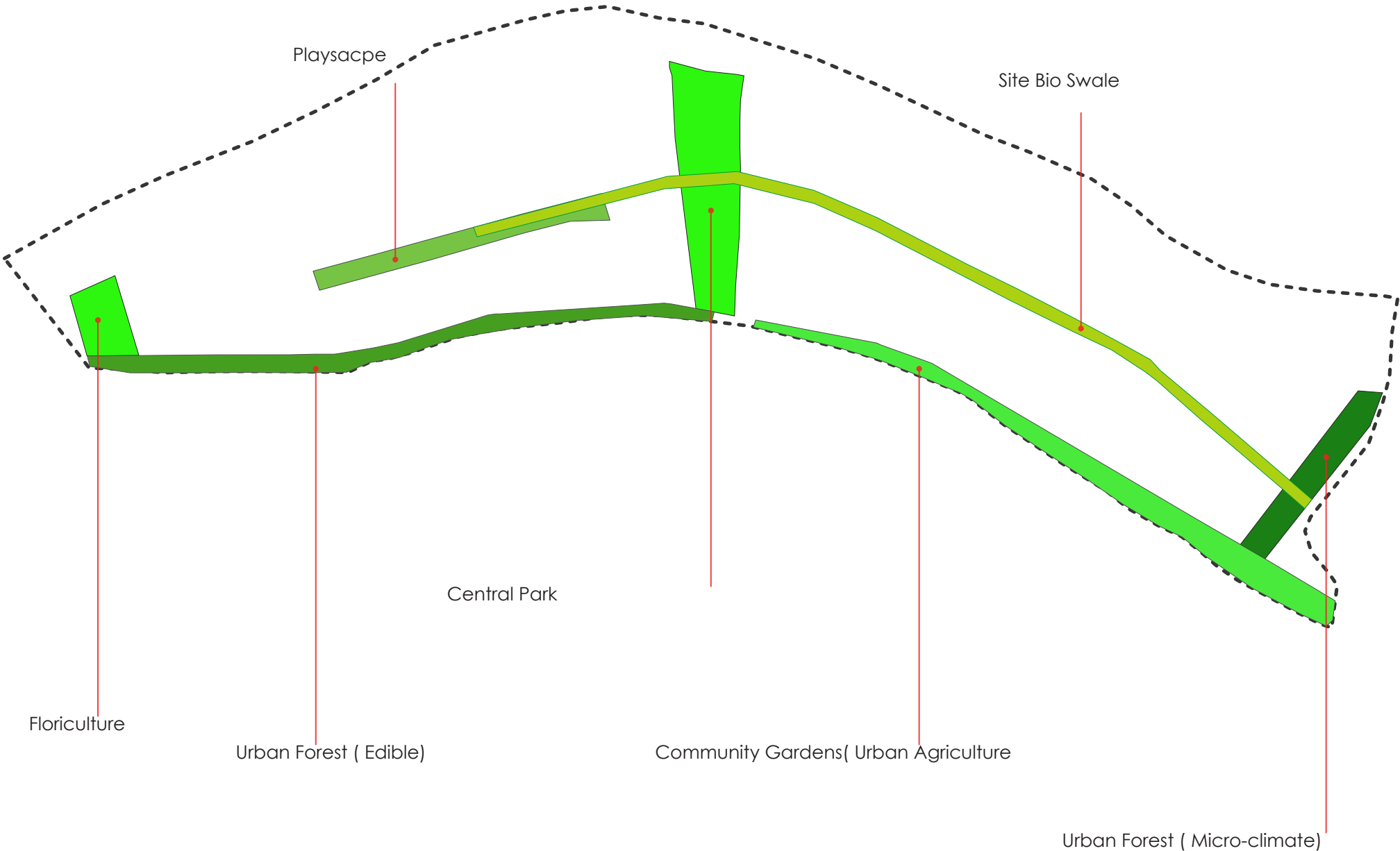

8.3.2. Nakivubo Canal Strategy

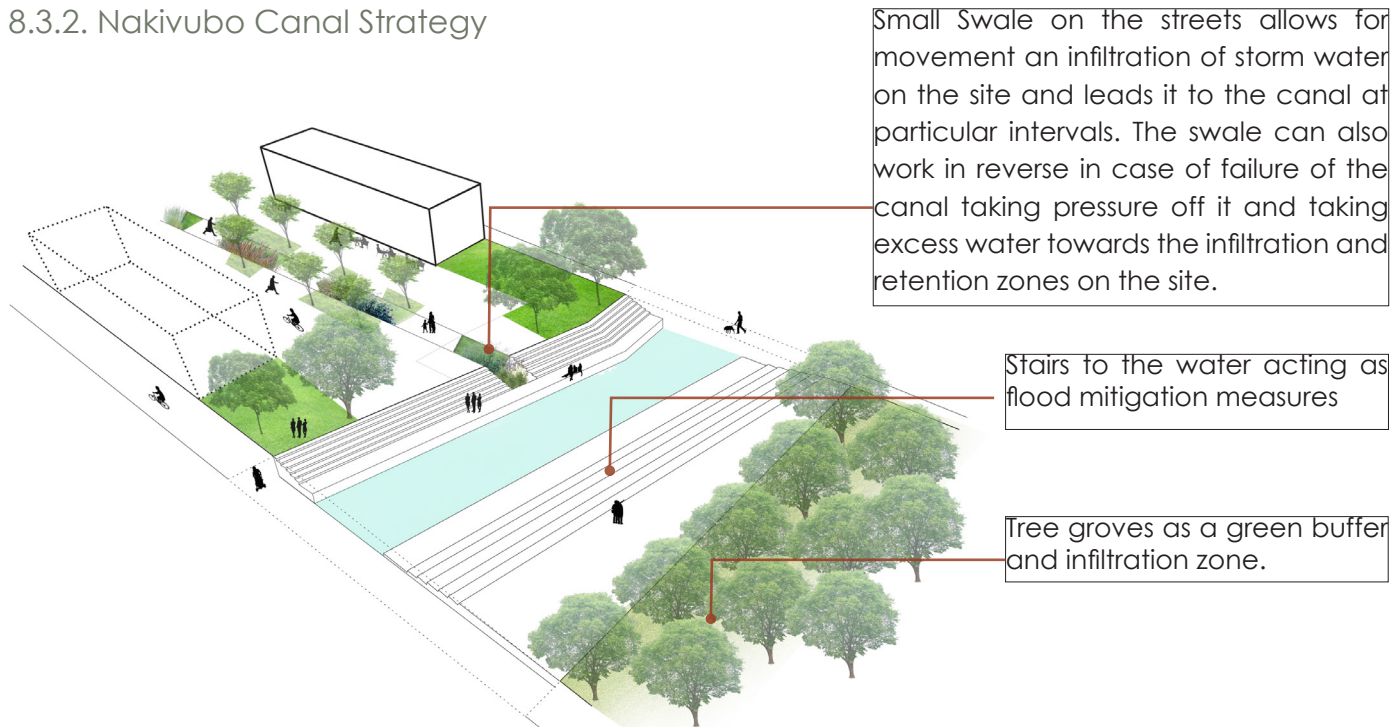

Dry Flood mitigation Measures

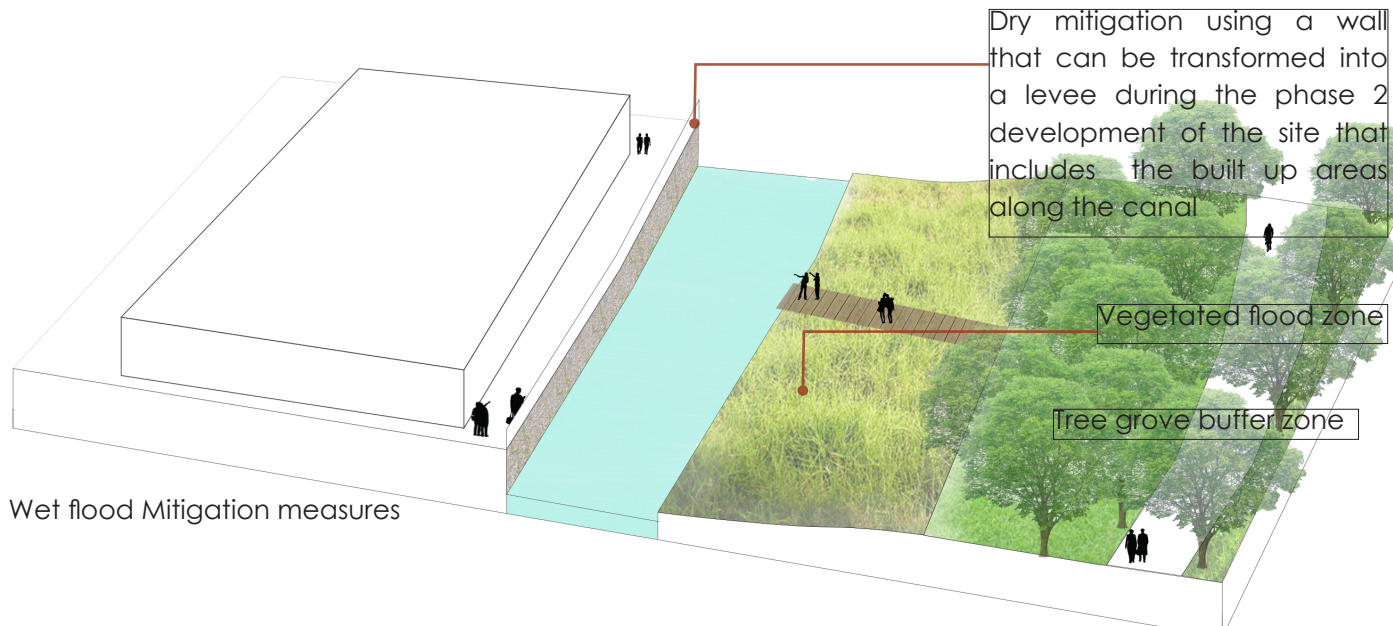

Wet flood Mitigation measures

Dry Flood mitigation Measures are used on the canal to create a floodable zone. The zone can be used during the dry months as public space and have an alternative and dual purpose of flood mitigation along the Nakivubo Canal. Green buffer zones such as tree groves are used to supplement the dry mitigation measures working as infiltration zones but also providing shade.

Wet flood mitigation measures are also used on the canal by creating swamp vegetation along the banks of the canal. The vegetation used should be able to withstand both wet and dry conditions. This type of mitigation not only helps improve the biodiversity along the Nakivubo canal but also adds a different experience along the canal. The green zone also helps to clean the water as it moves through the canal. The wet and dry flood mitigation measures can be used in tandem along different parts of the canal.

8.3.3. Street Strategy

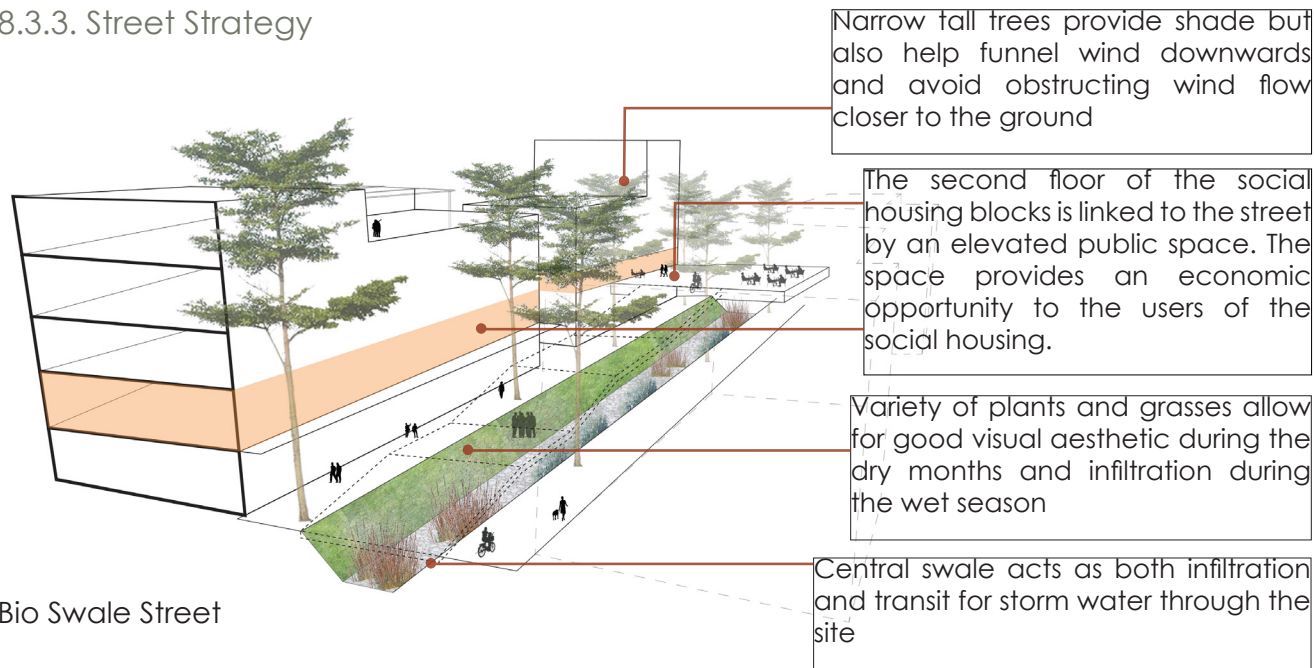

Bio Swale Street

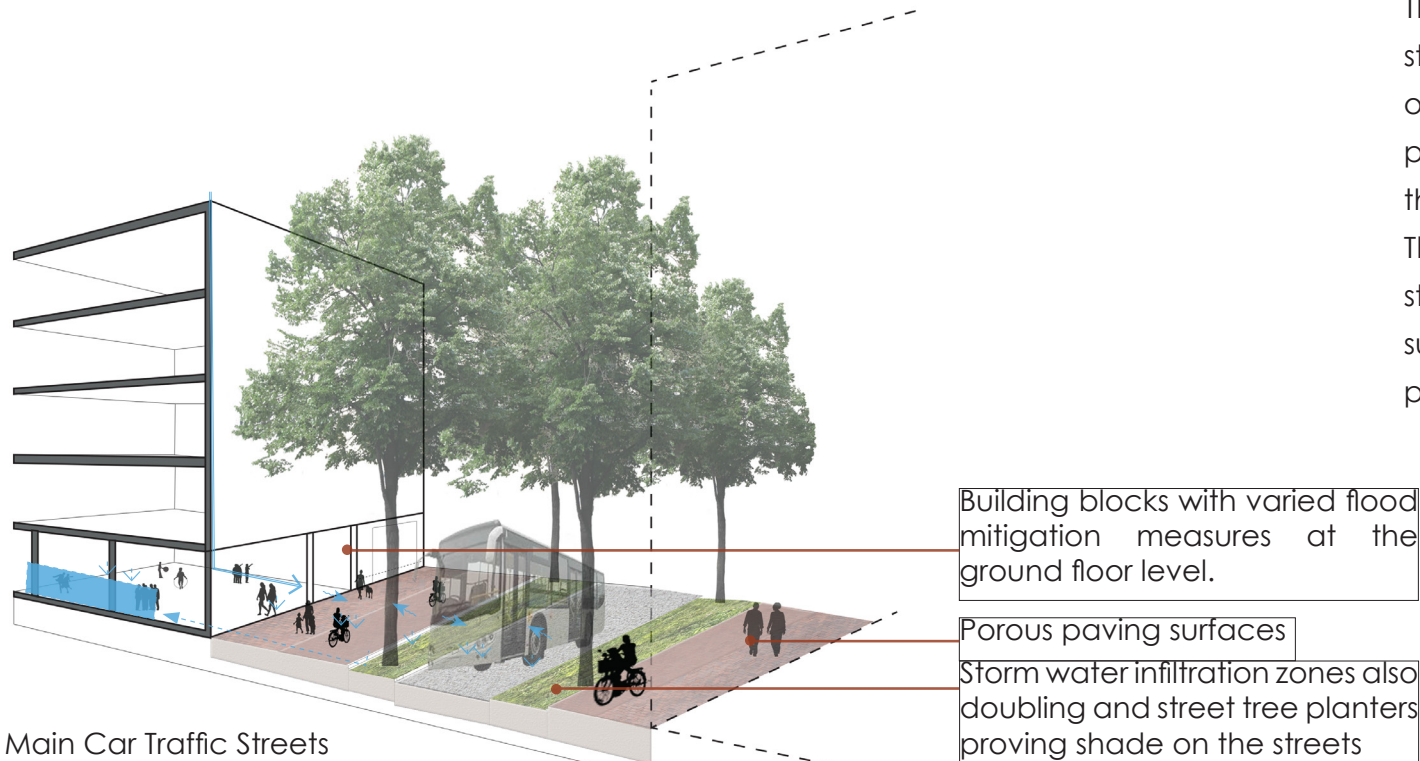

Main Car Traffic Streets

The streets are improved by giving them a better hierarchy in terms of pedestrian and vehicular access. Majority of the streets are limited to cyclist and pedestrians but are wide enough to allow movement of emergency as well as service vehicles. The streets also becomes public space where people can meet and interact. The use of permeable materials in combination with green infiltration zones allows for multifunctional, diverse and dynamic streets that give opportunity to create a vibrant street life.

The orientation of commercial store fronts to the streets also provides for active streets while the orientation of apartment windows to the streets provides for better well supervised streets making the area more secure.

The main car streets are converted into single lane streets with slow car traffic and more infiltration surface which in turn contributes to a better pedestrian experience.

8.3.4. Built Environments Strategy

Constructed Hills as landscape ornaments, water filtration, storage and distribution. The water filters vertically through layers of natural filtering materials

Elevated walkway doubles as water transit system in case of surface storage overflow

Surface Storm and rain water storage: water can be stored for irrigation and toilet flushing. Some of the water can be purified for more domestic needs.

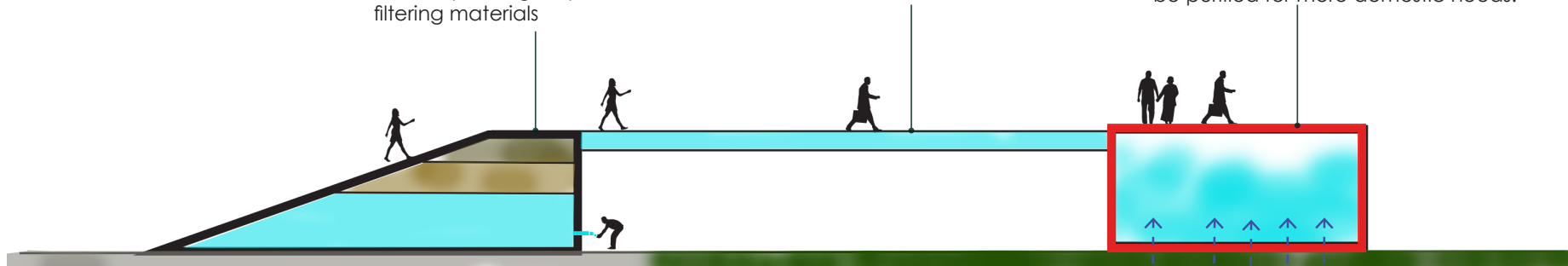

Ornamental Landscaping as a multi-functional space.

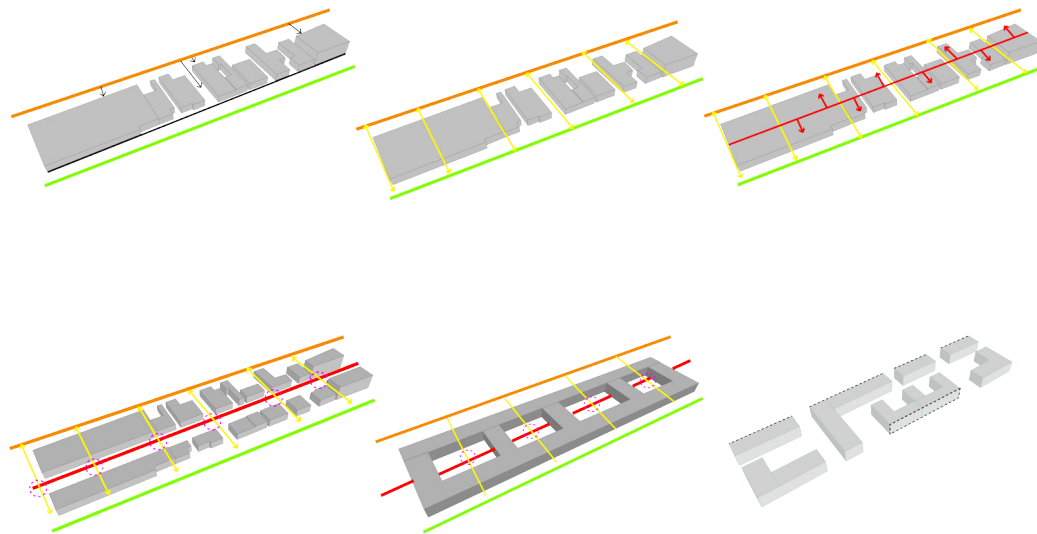

The existing blocks are large low rise industrial structures that cover over 70 - 100 of the plots in which they are. The new development block structure allows for more efficient land use and flows though the building blocks. The same area original covered by industrial blocks is transformed using the same plot area as the existing blocks making the area more dense but also increasing greenery and better circulation space within the blocks.

Comparison between efficient land use in the exiting area and the new area

8.3.5. Flood Proofing integration in the buildings typologies

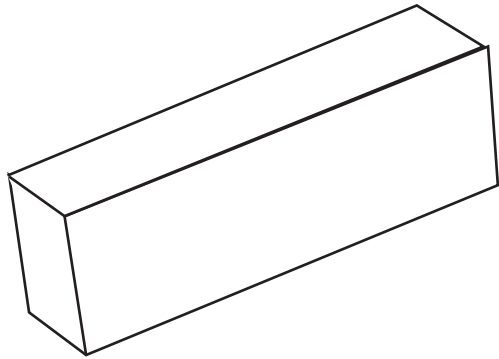

Simple common block structure

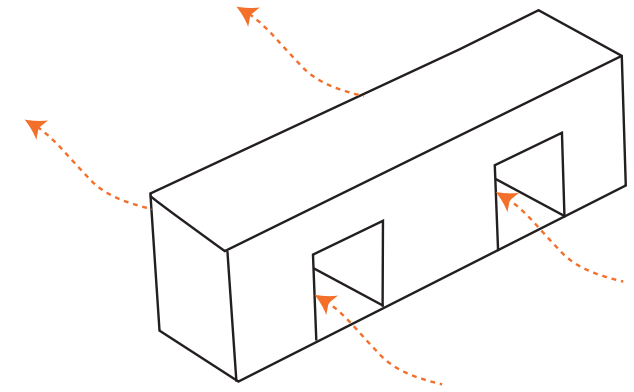

In this strategy spaces are left on the ground floor allowing for water to move through the building blocks into the neighbourhood scale infiltration zones. These spaces can also help with wind and pedestrian flows through the site.

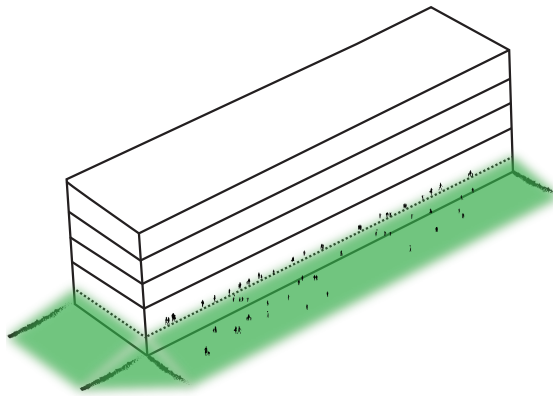

In this strategy the ground floor is elevated above the flood level which currently stands at 1m. Landscape sloping away from the building is also integrated within this mitigation measure providing a natural ramp to the ground floors abut also acting as a deterrent for storm water. The landscape also acts as a semi-public space and helps increase outdoor activity.

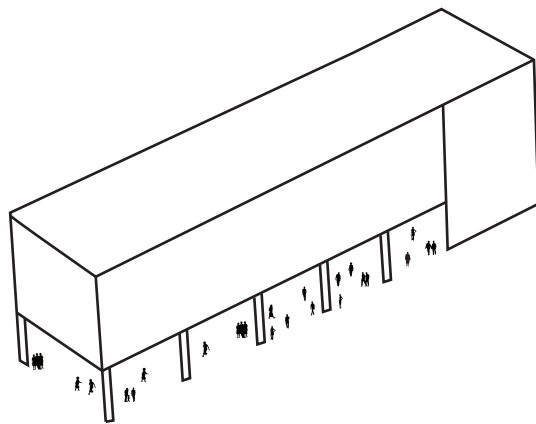

In this strategy the ground floor is left open to allow for flood water to go through. The open ground floor can be used for parking but also temporary programming for example, markets, exhibitions and play space. This can be used in tandem with other flood proofing like barrier and mechanical flood proofing creating a more dynamic street.

8.4 DESIGN DRAWINGS

8.4.1. Site Plan



8.4.2. Detailed Design (Mixed Use Community)

The new developments are designed as mixed use and multi function areas. The blocks are of varying sizes to allow for different functions i.e. Commercial, residential and or public use. The ground floors are designed to be used as commercial and office space but could also have part of the ground floor areas as residential spaces.

The apartments are of varying sizes to cater for different users. This is in combination with the provision of social housing allowing of integration of different social groups within the community. Different housing types within the neighbourhoods also improve the diversity of the buildings giving a vibrant and dynamic built environment.

The provision of generous quality outdoor space to encourage people into the outdoors where they can interact with one another and the biodiversity introduced on the site with this project.

Conclusively, the design brings the built environment, the landscape and the users together to create a sustainable urban community.



8.4.3. Design Sections
 Section of existing Fabric

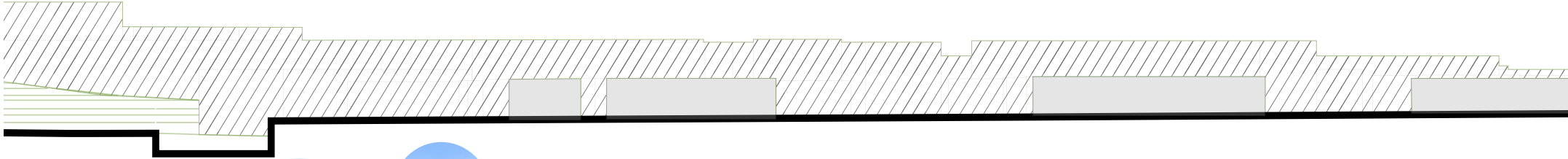

Potential Intervention



A tree covered infiltration zone acts as a buffer retaining and infiltrating storm water from the surrounds before it reaches the canal

A more active canal front doubling as a flood mitigation strategy

Bio Swale along the streets leading water to the canal but capable of working in reverse and taking the load of the Nakivubo Canal in case of failure

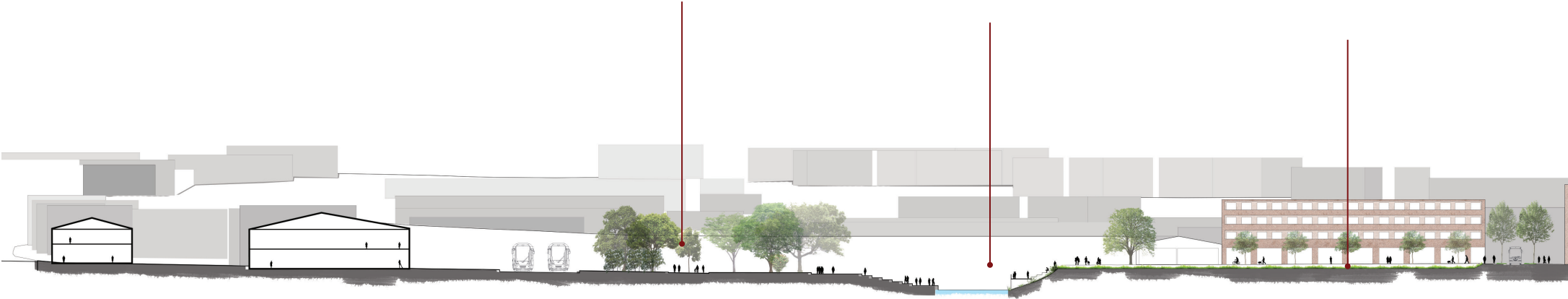

Section BB through site after intervention

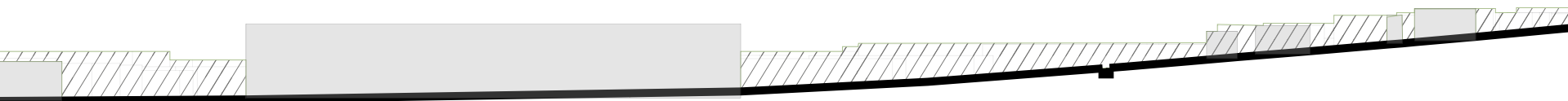

Site Bio Swale carries overflow down-slope towards the urban infiltration forest and the Nakivubo canal downstream closer to the Nakivubo Swamp

Existing industrial building reused as multi-purpose spaces

Elevated light rail creates a mass transit system without creating a barrier . it allows for permeability through the site and creates space under the rail for variety of functions including but not limited to storm water infiltration and small scale business.

Small scale Business kiosks

Central Park doubling as infiltration and retention zone

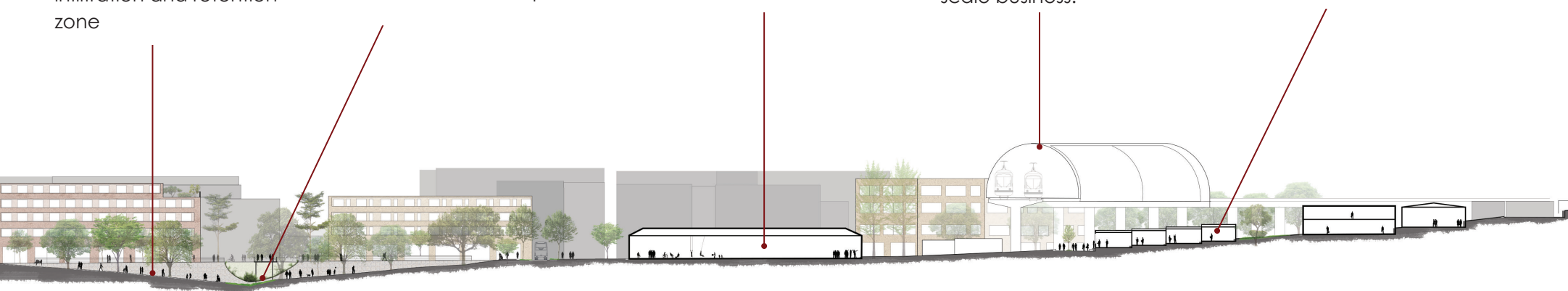

Section CC

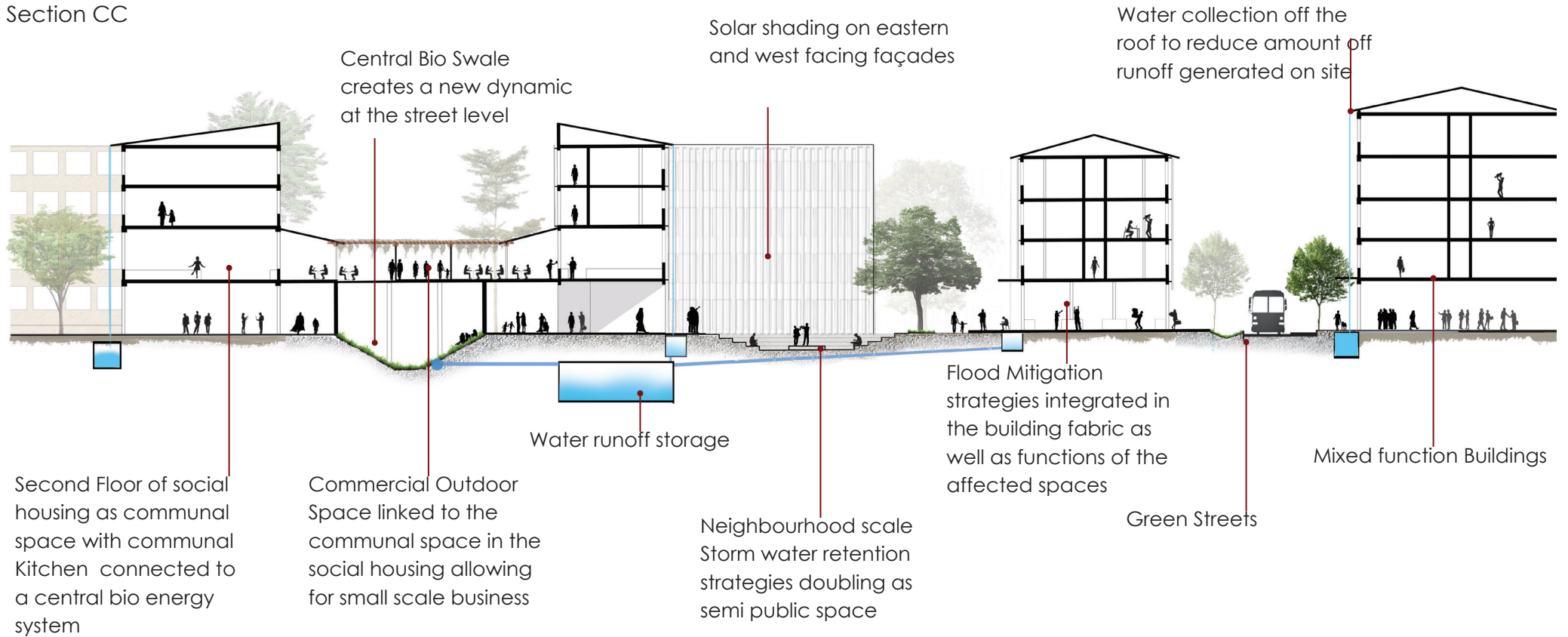

Section AA

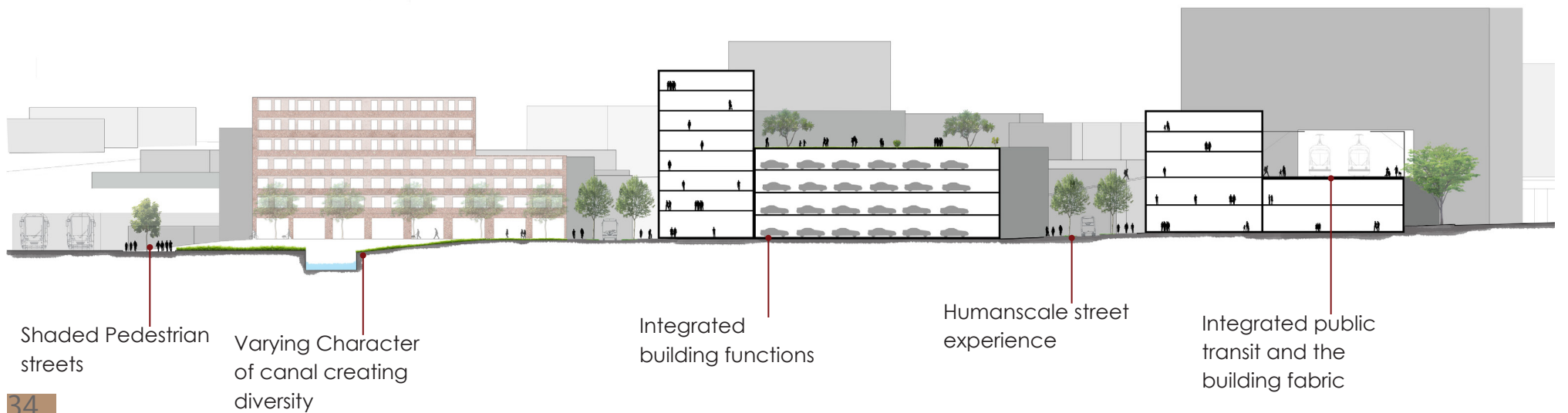

8.4.4. Artistic Impressions

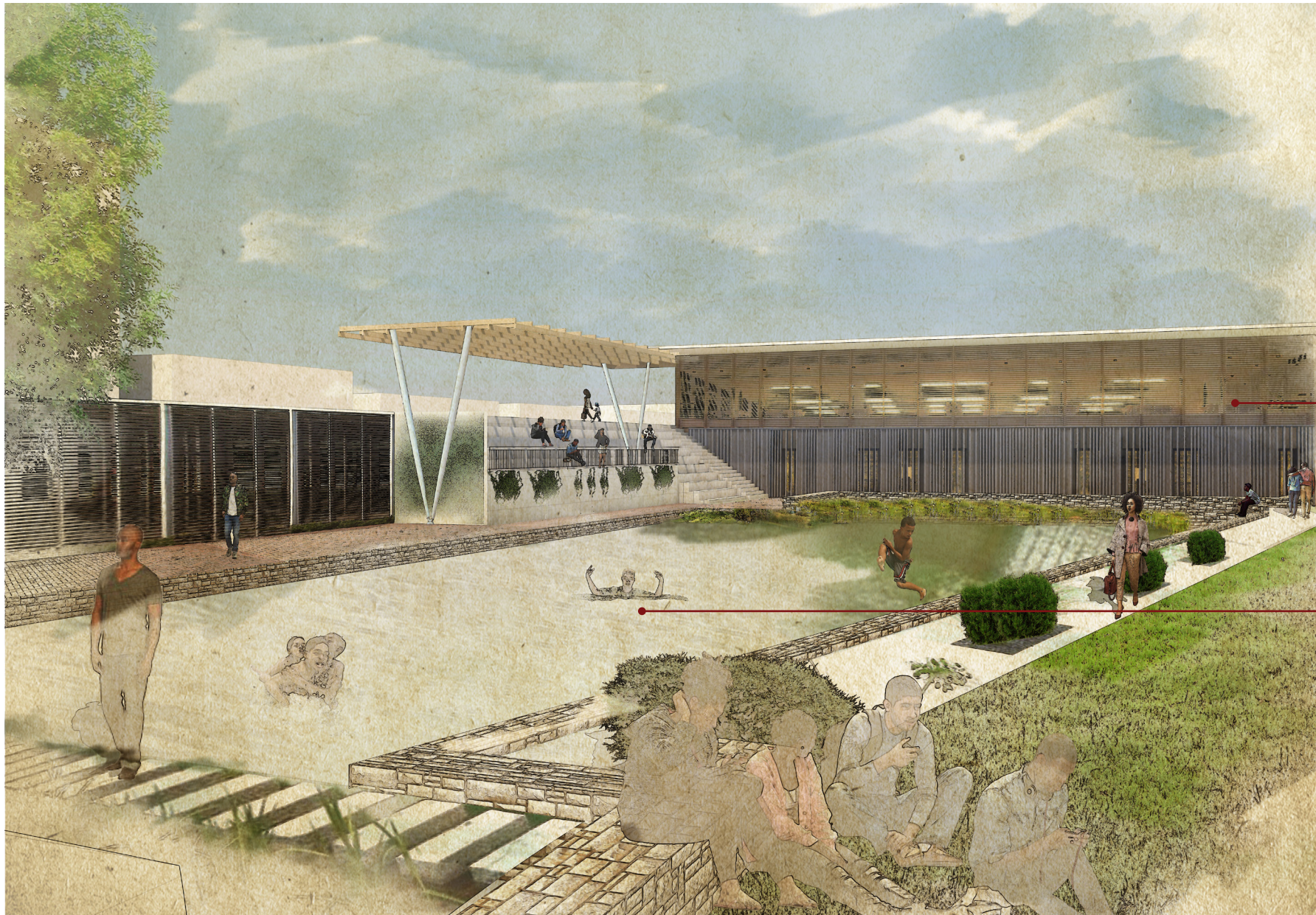

Community Centre

Wet storm water storage as natural public swimming pool

Perspective showing wet water storage pond as a multifunctional space



Open Market
as temporary
programming

Neighbourhood
scale storm water
retention area as
semi-public space

Perspective showing flood resilience strategies as modular spaces at the neighbourhood level

9. SUMMARY AND CONCLUSION



Built-Up Zones

	Zone A	Zone B	Zone C
Total Area	65343 m ²	119022m ²	61947m ²
Building Footprint	15797m ²	17413m ²	10357m ²
Landscape/ infiltration surfaces	76%	85%	83%

Functions distribution

	Zone A	Zone B	Zone C
Total floor Space	89503m ²	74638m ²	65564m ²
Residential	25334m ²	20999m ²	39203m ²
Commercial and office	50009m ²	46143m ²	26361m ²
Public	14130m ²	5074m ²	806m ²

Zone D Urban Fruit Forest 12125m²

Zone E Allotment Gardens 25250m²

CONCLUSION

The first phase of the development which is covered in this thesis provides accommodation space for approximately 3500 people, 122513m² of office and commercial space as well as 15443m² for public buildings. The proposed new development takes into consideration touching the earth lightly by reducing the building footprint while allowing for vertical mid-density development. The design allows for more areas as storm water infiltration and retention zones that also double public and semi public space.

The new development thus has a rich mix in terms of function size and distribution that allows for and creates a vibrant, dynamic and diverse neighbourhood.

All the five principles taken into consideration to drive the project come together to create a new resilient neighbourhood in an area that is currently an under-performing industrial zone. The proposal benefits both the people and the ecology of the site and Kampala City as a whole and would be a major step towards combating sprawl, climate change, the limited land situation and the associated problems that plague Kampala City today.

10. BIBLIOGRAPHY

- Ahern, J. (2013). **Urban landscape Sustainability and resilience: the promise and challenges of integrating ecology with urban planning and design.** Landscape Ecology Online: 10.1007/s10980-012-9799-z. <Available at <http://link.springer.com>> (Accessed on 12/02/2016)
- Coyle, S (2011). **Sustainable Resilient Cities: A Comprehensive Action Plan for Towns, Cities and Regions.** Hoboken, New Jersey, John Wiley and Sons Inc.
- Kampala City Council Authority, 2014. **Laying the Foundation For Kampala City Transformation: Strategic Plan 2014/15-2018/19.** Kampala:Kampala City Council Authority. Available at: <<http://www.kcca.go.ug>> (Accessed on 19/01/2016)
- Myers, G (2011).**African Cities: Alternative Visions of Urban Theory and Practice.** London, Zed Books Ltd.
- Omolo-Okalebo, F et-al (2010). **Planning of Kampala City 1903--1962: The Planning Ideas, Values, and Their Physical Expression.** Journal of Planning History 2010 9: 151 Available at<http://jph.sagepub.com/content/9/3/1_51> accessed on 08/02/2016
- Taylor, A and Camaren,P, 2014. **Strengthening climate resilience in African cities:A framework for working with informality.** African Centre for Cities. Available at <http://www.mistraurbanfutures.org>. (Accessed on 28/02/2016)
- UN-HABITAT, 2014. **The State of African Cities: Re-imagining sustainable urban transitions.** Nairobi: UN-HABITAT. <Available at <http://unhabitat.org>> (Accessed on 20/01/2016)
- Van der Griend R.A. and Siemonsma W.J.A. .2011. **Introducing Sustainable Urban Transport: A case of Kampala, Uganda.** Bachelor thesis. NHTV University of Applied Sciences Available at <<http://www.verkeerskunde.nl>>(Accessed on 17/05/2016)
- Vermeiren, K., et al. (2012). **Urban growth of Kampala, Uganda: Pattern analysis and scenario development.** Landscape Urban Plan. , doi: Available at<<https://www.researchgate.net>> Accessed on 02/04/2016
- Whyte, W.H (1980). **The Social Life of Small Urban Spaces.** New York, Edwards Brother Inc.
- Youqin,H (2012). **Low income Housing in Chinese Cities:** Policies and Practices. The China Quarterly, 212, pp 941964. Available at < <http://www.albany.edu>> accessed on 29/07/2016