



**LUND**  
UNIVERSITY

# **The *limes* of Roman Dacia near the auxiliary fort of Bologna**

---

**An application of GIS viewshed analysis**

**Author: Nogyi Edmond**

**Supervisor: Henrik Gerding**

**Supplementary Supervisor: Nicolò Dell'Unto**

**Master's thesis in Classical Archaeology and Ancient History**

**Spring 2017**

**Department of Archeology and Ancient History**

## Abstract

This thesis examines the frontier defensive system found in the vicinity of the Roman auxiliary fort near modern-day Bologa, Cluj County, Romania. The goal is to study the visual relationship between the more certain watchtowers and the other military installations (the auxiliary fort and other fortlets) to understand how arrangements and visibility might have contributed to the functioning of the local and the provincial defensive system. Although the study focuses only on a smaller section of the Roman frontier, and covers a more limited timeframe (second to third century), the results obtained might be relevant to other parts of the Roman Empire, where characteristics similar to this section had been found. Frontier defences were important for preserving peace and stability within the borders of the Empire, and studying them would help researchers understand how that was achieved at different times in different places. In the first part of my thesis, a general overview of Roman military installations and frontiers is provided. Next, the research history of the sites examined in this study is presented, followed by a more detailed discussion about the aims, sources and methodology. After that, the type of analysis performed in this thesis is explained, followed by a step by step documentation of the entire process. Towards the end, the results are presented, discussed and interpreted in relation to previous research on these archaeological sites, but also in relation to those found in other relevant locations, as well as Roman provincial and imperial defenses in general. The conclusion is that this section of the *limes* seems to display characteristics typical for a defensive system.

Keywords: Roman frontiers, *limes*, Roman army, watchtowers, signaling, Roman Dacia



## Table of contents

<b>Abstract</b> .....	<b>2</b>
<b>1. Introduction</b> .....	<b>4</b>
1.1. Background.....	4
1.2. Research history.....	6
1.3. Aim.....	11
1.4. Sources.....	11
1.5. Methodology.....	12
<b>2. GIS viewshed analysis</b> .....	<b>13</b>
2.1. Theoretical framework.....	13
2.2. Preliminary work.....	16
2.3. Workflow.....	22
2.4. Results.....	24
<b>3. Discussion</b> .....	<b>85</b>
3.1. The local defensive system.....	85
3.2. Communication.....	89
3.3. The local garrison.....	91
3.4. The defences of Roman Dacia.....	92
3.5. Final remarks.....	94
<b>4. Conclusion</b> .....	<b>95</b>
4.1. Acknowledgements.....	96
<b>5. References</b> .....	<b>97</b>
5.1. Literature.....	97
5.2. Resources and tools.....	102
<b>6. Appendices</b> .....	<b>109</b>
6.1. List of sites.....	109
6.2. List of plates.....	111
6.3. List of figures.....	129
6.4. List of tables.....	131

## 1. Introduction

This chapter is divided into five subchapters. In the first one, a short introduction to Roman frontier studies is provided. It explains where the study area is located, but it also gives a general overview of the topic researched here. The next subchapter presents the research history of the archaeological sites. The various types of military installations are referred to using the English terminology presented in the previous subchapter, and the sites distinguished through numbers issued in north-south and west-east directions. Next, the purpose is stated in relation with what has been done before in the same study area. After that, the type of sources and what they were used for is described. The final subchapter presents the overall methodology applied for obtaining the final results.

### 1.1. Background

The archaeological sites examined in this study are located in the central north-western parts of modern-day Romania (Figure 1). Even though a very precise chronology has not yet been established, most of them are certainly dating from the Roman period. It is commonly believed that they were part of the *limes*, due to their aspect, the type of finds discovered there, and their proximity to the bigger military sites, like auxiliary forts.<sup>1</sup>

In historical sources, especially from the early imperial period, the term *limes* was used in reference to roads built and used by the Roman military in conquered territories, or simply land boundary, internal or external, but not necessarily a fortified one. River boundaries on the other hand, were called *ripae*. Only later, starting from the fourth century, the word was used for a frontier district, and received administrative connotations. However, when Roman frontier studies developed in the nineteenth century, *limes* came to represent a defensive system built along borders from the first century onwards. Since then, it has often been applied to frontier areas that contain remains of various types of structures meant for military use.<sup>2</sup>

Installations of the Roman army of the Principate usually included: legionary fortresses (*castra*) for garrisoning the larger units of higher-status soldiers, auxiliary forts (*castella* or *castra*) for the smaller units of lower-status soldiers, fortlets (*praesidia* or *burgi*) for small detachments operating further from the bigger bases, watchtowers (*burgi* or *turres*) for surveilling specific areas, linear defenses (*clausurae* or *valla*) made of earth, stone and/or wood usually reinforced with ditches, and military roads connecting all the installations. However, not all of the aforementioned components are found on every frontier, or even on every section within the same province, because the defensive system was never uniform throughout the Empire.<sup>3</sup>

---

1 Marcu and Cupcea 2015, p. 70.

2 Isaac 1988, pp. 126-133.

3 Cupcea 2015, pp. 15-17.

In the area I have examined, a number of seven fortlets, fifteen watchtowers, five places with linear defenses and one auxiliary fort were reported to have existed with varying levels of certainty. They were constructed sometime after 106, following the conquest and creation of the Roman province of Dacia, and were most likely abandoned soon after 271.<sup>4</sup> Since they were part of the frontier defensive system belonging to Roman Dacia, they should be a testimony to the existence of the *Limes Dacicus*. However, unlike the *Limes Rhaeticus*<sup>5</sup>, or the *Limes Tripolitanus*<sup>6</sup>, it never appears explicitly in literary or epigraphic sources<sup>7</sup>. Both Eutropius and Rufus Festus estimated that the frontier of Roman Dacia was about 1000 Roman miles long.<sup>8</sup> To differentiate between various sections of the *limes* more easily, they were given artificial names in the modern literature I have consulted. The monuments studied in this paper are sometimes referred to as being part of the so-called *Limes Porolissensis*, because they were located in the northern administrative subdivision of Dacia, called Dacia Porolissensis. However, the north-western section of the *Limes Porolissensis* is referred to as the *Meseş limes*, because it fully covers the Meseş mountain range. Nevertheless, such a distinction probably never existed in reality, and it is unclear what the official name for this province's frontier was during the second and third centuries.

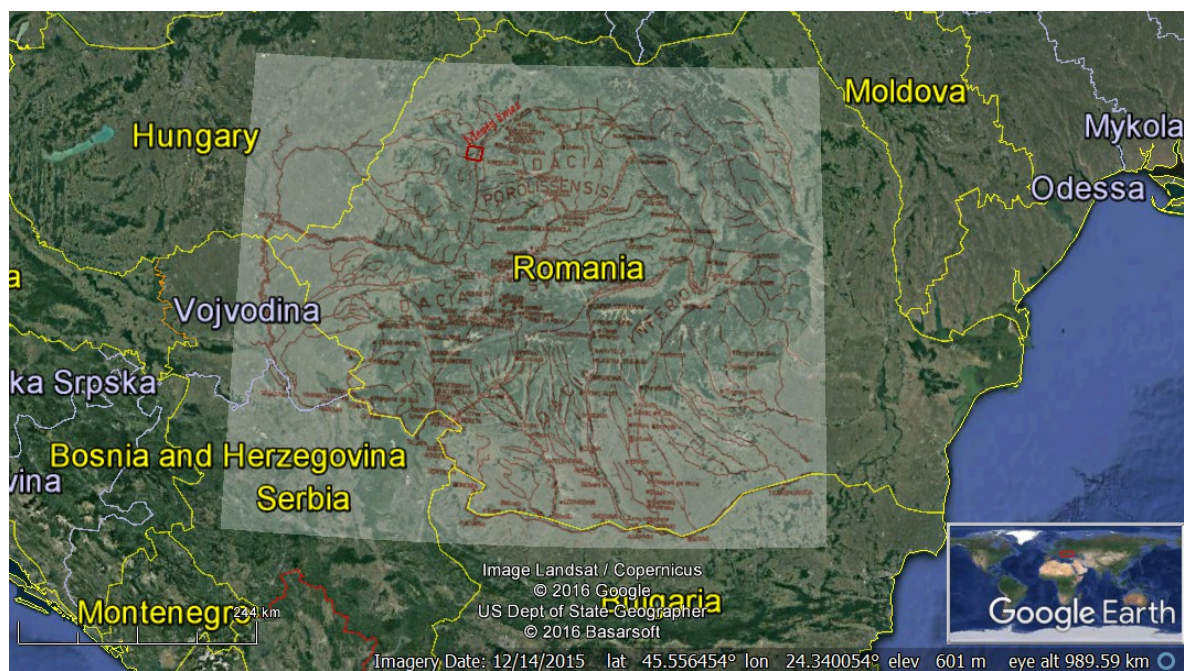

Figure 1. Locations discussed in subchapter 1.1. Background - the red box highlights the study area, the Roman administrative subdivisions represent the situation during Hadrian's reign (Literature: Bărbulescu 2005, p. 19. Resources and tools: GIMP; Google Earth 2015.1).

- 4 Oltean 2007, pp. 41-58. See more information in English about the events leading up to the formation and the administrative organization of Roman Dacia.
- 5 ILS 451.
- 6 ILS 8923.
- 7 Ruscu 2003 cited in Marcu and Cupcea 2013, p. 570.
- 8 Gudea 1979, p. 65.

The role of *limites* has been debated for quite some time, and multiple views emerged over the past decades. It was initially thought that they served as political, social and cultural barriers between Romans and those living outside the borders. According to another theory, they had a strictly military purpose, and were the product of a 'grand' strategy formulated by the central authority and applied to every province uniformly. Some viewed the frontiers as structures that encouraged and guaranteed the economic growth and romanization of the provinces they protected, but others stated that they were purely psychological barriers. There are even some who believed that they represented defenses resulting from external political and military failures.<sup>9</sup>

## 1.2. Research history

It was in the second half of the nineteenth century, that scholars from Transylvania started to show interest in Roman Age sites in general. However, only after the discovery of an inscription from Cășeiu<sup>10</sup>, the search for the *limes* of Roman Dacia began. Although many considered that Torma Károly had interpreted the inscription wrongly, he still believed in the existence of a *limes* with a *vallum* in north-western Transylvania. In 1862, while exploring those parts, he came across six Roman forts, and assumed that the frontier stretched from modern-day Poieni to Tihău.<sup>11</sup> The sites he was referring to were the ones near modern-day Bologa, Buciumi, Românași, Romita, Moigrad-Pomăt and Tihău (Figure 2), but he only used them as a means to infer the existence of the *limes* at that stage.

Nevertheless, the area came to the attention of more enthusiasts. In 1863, Finály Henrik made a short trip to the surroundings of Poieni and Bologa, and described the ruins of the Auxiliary fort and Fortlet 2 (Figure 3). His contribution was highly descriptive in nature, since he only provided information concerning the general location, the types of material scattered on the surface, the aspect and size of the ruins. No drawings were provided, and no excavations were made at that time.<sup>12</sup>

Some scholars did not find Torma's argument convincing enough, because it was mostly based on a misread inscription, and more concrete *limes* specific remains were not known yet. This encouraged him to renew his efforts, and in 1879, he found a number of watchtowers, fortlets, and some portions with linear defenses. In his documentation, the author divided methodologically the *limes* in these parts into five sections, the area surrounding Poieni and Bologa being part of the first one. In this section, besides providing a more detailed account of the Auxiliary fort, and repeating Finály's discovery, he documented one more fortlet (Fortlet 3), Linear defenses 2, and seven watchtowers - Watchtowers 4, 5, 6, 7, 10, 11, 12a or 12b, but the last two he only recorded from oral accounts. He followed the same method of documentation as Finály, only that he also did some hand drawings and unsystematic test-

---

<sup>9</sup> Karavas 2001, pp. 8-16.

<sup>10</sup> CIL III 827 = CIL III 7633. .../ a cens(ibus) sub sig(navit) / Samum cum reg(ione) / [tr]ans val[lu]m / ... instead of .../ agens sub sig(nis) / Samum cum reg(ione) / Ans(amensium) v(otum) l(ibens) m(erito) / ...

<sup>11</sup> Torma 1880, pp. 3-5.

<sup>12</sup> Finály 1864, pp. 5-9.



digging occasionally. Additionally, Torma did an informal line of sight analysis, to argue for the character and purpose of those structures, as well as discussed the possible *limes* road network in the area.<sup>13</sup> Although the Auxiliary fort, like many similar ones, was immediately recognized as a Roman site, and has been studied ever since<sup>14</sup>, the minor features did not get much recognition until later.

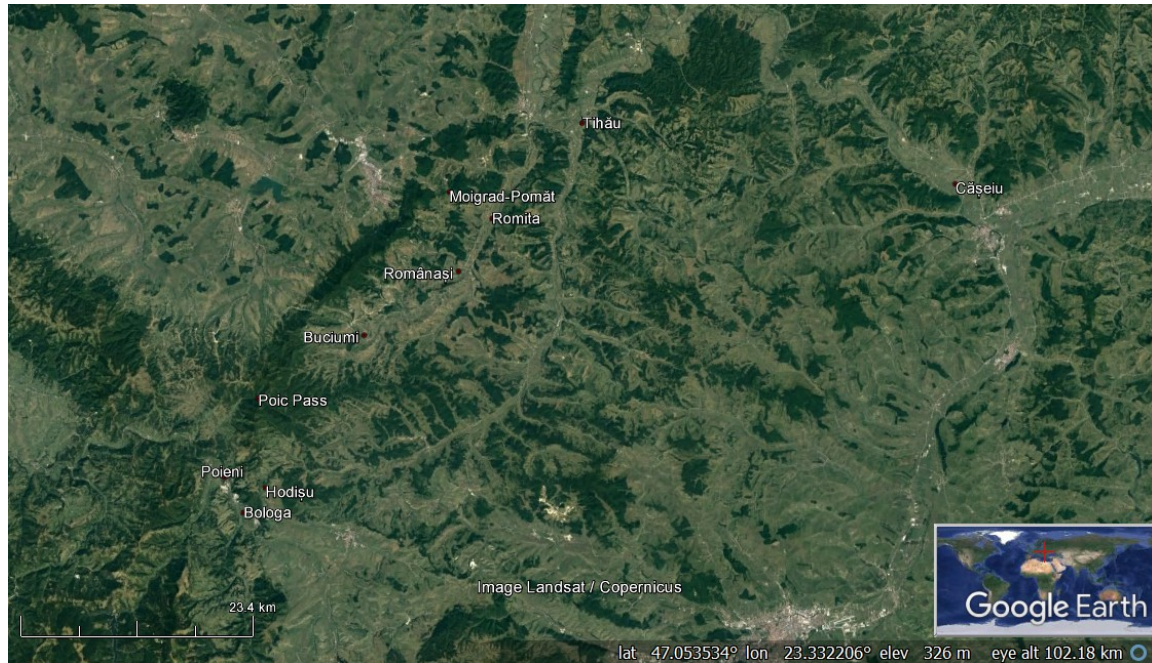

Figure 2. Locations discussed in subchapter 1.2. Research history - the so-called Meseş *limes* stretching from modern-day Bologna and Poieni to Tihău (Resources and tools: GIMP; Google Earth 2015.2).

After almost thirty years, it was Téglás Gábor who resumed studying the Meseş *limes*. In 1906, he did some field walking, but he limited his survey to the area between Poieni and the Poic Pass, that is Torma's first section. Téglás mentioned or updated the previously known sites - Fortlet 3, Watchtowers 4, 5, 6, 7, 10, 11, and Linear defenses 2; but he also signaled the presence of new ones - Watchtowers 3a or 3b, 8 or 9, 13, and Fortlet 7. The author also signaled the presence of Linear defenses 5, which he believed to be Roman. Moreover, he speculated that there might have been a palisade running close to the road that connected all the watchtowers, sections of which he thought to have survived along Linear defenses 3 and 4. Although his study was built on the same documentation methods, the author used analogy as an analytical method, having personally visited the *limites* of some foreign countries a couple of years before. Téglás used his experience to argue for the existence and functionality of various structures, but he explained the lack of ditches or ramparts in some parts with environmentally deterministic arguments.<sup>15</sup>

13 Torma 1880, pp. 9, 13, 41-80.

14 Gudea 1997, pp. 11-13; Marcu and Cupcea 2015, pp.75-80.

15 Téglás 1907, pp. 572-576.

The scholars of that time followed those developments with interest, but overall, many were still sceptical. Even though sites with artefacts, like fortlets and watchtowers, were unquestionably Roman, the linear defenses were still a heated debate topic. Some, like Buday Árpád, were not fully convinced by Téglás's analogies regarding ditches, ramparts and roads in particular. Therefore, Buday explored the area between Poieni and Moigrad-Pomăt in 1911, to evaluate the condition of the previously reported features. Between Poieni and the Poic Pass, he came across the older sites - Linear defenses 2, Watchtowers 4, 5, 6, 7, 10, 11, 12a or 12b and Fortlet 7. However, he also recorded some new sites, like Watchtowers 3a and 3b, 9, Fortlets 5 and 6. As Téglás, he thought that there might have existed a palisade with a small ditch and rampart, but only at Linear defenses 3. His report was sketchier than the previous ones, especially regarding older discoveries. Like Téglás, Buday also relied on personal experience acquired during his visit to the germanic *limes*, and made ample use of analogies. The author not only provided hand drawings, but also terrestrial photographs sometimes, the latter being used for the first time here, on the Meseş *limes*.<sup>16</sup>

Buday's efforts eventually convinced the international community to officially recognize the Roman character of these frontier defenses, yet the problems regarding ditches and ramparts was not solved yet. Constantin Daicoviciu for example, doubted the artificiality of such linear defenses. Even though he examined the areas surrounding Poieni, Buciumi and Moigrad-Pomăt at an unknown date, he believed that a Roman *vallum* was only present around Moigrad-Pomăt, which he also had the occasion to test through excavation. He also doubted the character of Fortlet 3, since the site had already been covered with modern constructions during Téglás's survey.<sup>17</sup>

On the other hand, towards the end of the Second World War, Radnóti Aladár tried to contradict Daicoviciu, by using for the first time aerial photography to study the Meseş *limes*. The photographs he used covered areas surrounding Bologna, Hodişu, Buciumi and Moigrad-Pomăt. In the area surrounding Bologna and Hodişu, some of the previously known sites were visible in the images - the Auxiliary fort, Watchtowers 6 and 7; but some other features were also captured, which Radnóti believed to have been Roman - Fortlets 1, 4, and Watchtower 1, only the latter was thought to be a fortlet. Furthermore, he believed he identified some new earthworks - Linear defenses 1, and argued for the artificiality of Linear defenses 4. The author did not use analogies in his study, but he tried to argue for the defensive system using strategic arguments. Although his contribution was valuable for signaling various features, they did not have the desired effect, for only ground surveys and excavations could provide answers to those questions.<sup>18</sup>

In 1947, Ferenczi István set out to verify the features Radnóti had noticed in the area west of Hodişu, south of Poieni and west of Bologna. According to him, Linear defenses 1 was a natural water drainage channel, Linear defenses 3 was a field division, and Linear defenses 4 were plow marks or some similar signs of activity. He argued that the only Roman artificial feature was Linear defenses 2. The author denied the existence of Fortlets 1 and 4, but

---

16 Buday 1912, pp. 103-116.

17 Daicoviciu 1936, pp. 254-256.

18 Radnóti 1944-45, pp. 137-151.

acknowledged that there might have been watchtowers at Watchtowers 1 and 2. Additionally, he mentioned and updated some of the older sites: Fortlets 2, 3, Watchtowers 3a, 3b, 4, 5 and 7. Ferenczi's account was mainly based on personal observations however, no excavations were done, and no hand drawings or any other graphical documentation were provided.<sup>19</sup> Moreover, Ferenczi continued his work on the Meseş *limes* over the next years. In 1965, he did another field survey, but this time covering the area between Poieni and Tihău. Many of the previously known sites were seen at that occasion, since his goal was to create an up-to-date compendium of all the Meseş *limes* defenses. He made a classification of fortifications based on fortlets, linear defenses and watchtowers, but the author also analysed the frontier's characteristics and function as a unitary system. Nevertheless, the methodology he used when documenting and redocumenting the sites seldom included excavations, but was more or less the same as his predecessors'.<sup>20</sup>

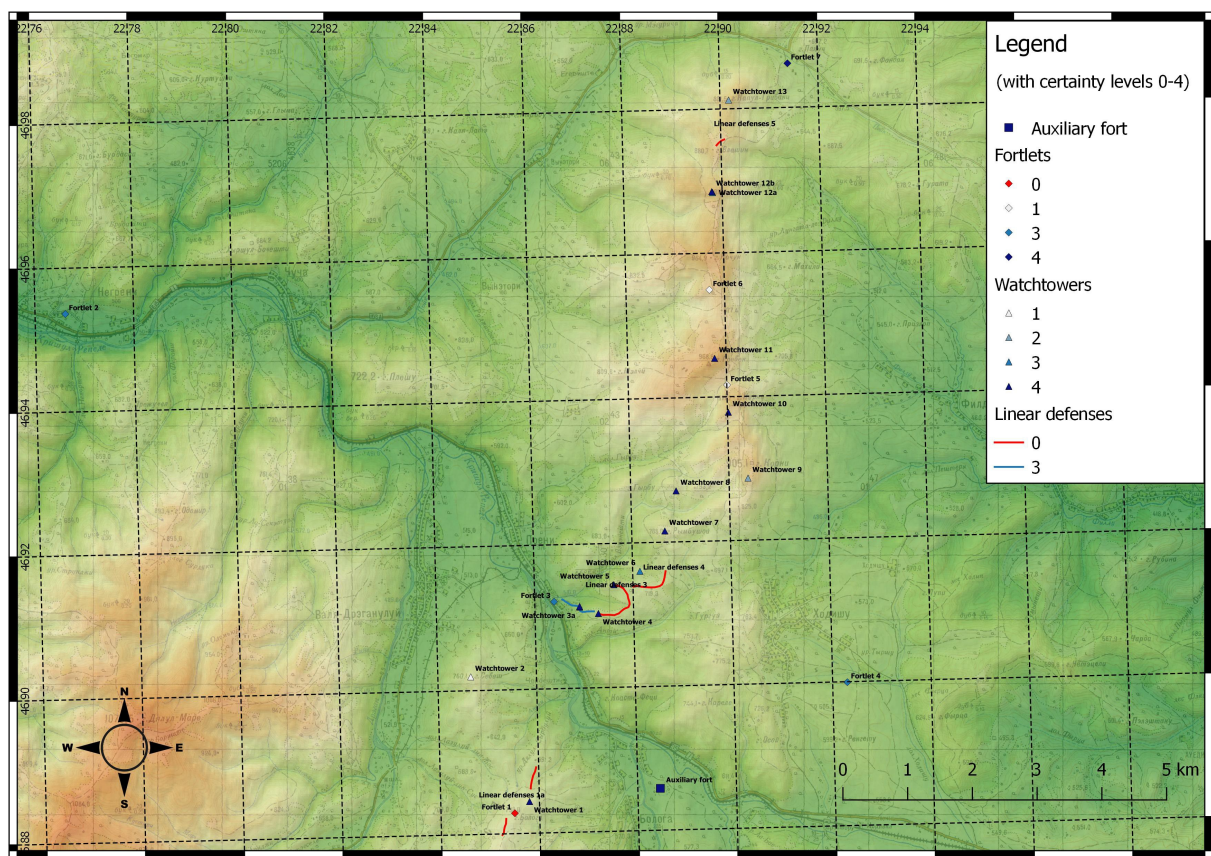

Figure 3. The study area with all the archaeological sites - more information about each site is available in 6.1. List of sites from the Appendices section (Resources and tools: ASTER Global DEM - 30 m; QGIS; Soviet Topographic Maps 1: 50 000).

19 Ferenczi 1959, pp. 338-350.

20 Ferenczi 1968, pp. 75-98.



Around the same time, Nicolae Gudea also started his research on the Meseş *limes*. In the first phase, he focused his attention on the area between the western parts of Bologa and the Poic Pass. After that, he continued his field work northwards, until reaching the surroundings of Tihău. His objective was to survey the *limes*, and systematically verify through excavation as many surviving sites as possible. Although none of the features were entirely excavated, Gudea's thorough documentation provided much valuable information. For what concerns these parts, the sites he excavated were: Fortlet 7, Linear defenses 2, Watchtowers 1, 2, 3a, 3b, 4, 5, 6, 7, 8, 10, 11, 12a and 12b. The sites he only surveyed were: Fortlets 2, 4, 5 and Watchtower 9. The author established that most sites were dating from the Roman period, but less likely Watchtower 2. He also expressed doubts about a number of sites, because he could not locate them, they were damaged or fully destroyed, or yielded insufficient data. Such was the case with Fortlets 3, 5, 6 and Watchtower 6.<sup>21</sup> Like Ferenczi, Gudea also made a compendium of all the Meseş *limes* fortifications, and analyzed the defensive system from an overall perspective as well. As Torma, he divided methodologically the study area into five sections, and made multiple classifications of fortlets, linear defenses and watchtowers based on: location in relation with different types of terrain, distance between sites, shape, dimension, dimension in proximity to auxiliary forts, visual range and signaling capability. However, the classification based on the last two criterias was made through informal line of sight analysis, performed from the human height level, with all the obstructions caused by the local vegetation.<sup>22</sup>

More recently, Felix Marcu and George Cupcea studied parts of the Meseş *limes* by doing a formal type of visibility analysis in a GIS. The research they conducted was limited to the area surrounding Bologa and the northern parts of Poieni, but no further than Watchtower 11. The sites the authors analyzed were: the Auxiliary fort, Watchtowers 1, 3a, 3b, 4, 5, 6, 7, 8, 9, 10 and 11. They relied on previous accounts for locating the sites during their survey, but they admitted that Watchtowers 9 and 10 had been uncertain in the field. In Global Mapper GIS, they did a binary viewshed analysis using the following parameters: 20 km for the maximum visual range, and 8 m for the observer height. The obtained results made it possible to assess the visual range of the above mentioned towers, from a higher and possibly more accurate level than the human height. However, for all the examined watchtowers the same observer height value was applied, but not all structures are known to have had an equally large base. Although the analysis permitted the authors to evaluate the importance and functionality of various watchtowers, their results did not take into account multiple levels of certainty that usually characterize the real-world visual experience.<sup>23</sup>

---

21 Gudea 1971, pp. 507-519; Gudea 1985, pp. 159-165.

22 Gudea 1985, pp. 143-158.

23 Marcu and Cupcea 2013, pp. 569-589; Marcu and Cupcea 2015, pp. 67-74. For some reason, Watchtower 1 was mapped around 1.4 km southwest from where it had previously been reported by Radnóti and Gudea (see Plate 14 in 6.2. List of plates). In my thesis, I chose the old location of this tower for the analysis. All the other site locations match the places they had been reported in previous reports.

### 1.3. Aim

The purpose of this study is to investigate the Roman defensive system present near the auxiliary fort of Bologna. Considering how long and complex the *limites* of various provinces were, research is usually restricted to smaller sections at a time. It is common knowledge that the defensive system was not temporally or geographically uniform throughout the Empire. Nevertheless, visibility and intervisibility are usually considered crucial when it comes to defensive systems in general. The larger the visually controlled areas are, the faster can movements be spotted. The earlier this happens, the more time defenders have to prepare for the encounter. If multiple positions are occupied at the same time, normally it is advisable to have visual ranges that complement one another to avoid enemy encirclements. Intervisibility between different sites may also be important for visually communicating messages concerning enemy movements, if a certain code existed and was agreed upon. However, visual communication can be done by various means in different conditions, not to mention that acoustic means may be just as efficient sometimes. My intention is to establish to what extent this section of the *limes* displays characteristics typical for a defensive system. The purpose of this study is to examine the signaling arrangements, and how they may have affected the general layout of the system. Although a similar method was recently used for studying the same area and topic, my goal is to try a different viewshed approach by performing visibility analyses on the watchtowers with known dimensions only. The ones left out are badly preserved or very uncertain, and their exclusion impacted the overall results. In the literature, it is debated what the real purpose of the Roman *limites* was, and this investigation may perhaps shed more light on this. For better understanding the purpose and the context of the local defensive system, I will also examine the similarities and differences between this *limes* and the ones from other provinces, as they appear in the studied area.

### 1.4. Sources

In my research I used two types of literature. For obtaining qualitative information about each archaeological site, but also other sites and Roman defensive systems in general, I consulted the relevant modern literature. On the other hand, the historical literature proved more useful for reconstructing the sites, and for understanding the historical context. To obtain the spatial information needed for the analysis, aside from the published reports that occasionally came with drawings and some aerial or terrestrial photographs, I used Romanian 1:20 000 and Soviet 1: 50 000 topographic maps<sup>24</sup>, as well as satellite imagery accessed through Google Earth. For the analysis, I opted for the 30 m resolution digital surface model acquired in 2000 by the Space Shuttle Endeavor's Shuttle Radar Topography Mission. To my knowledge, there was no higher resolution free dataset available at that time.

---

24 Romanian Topographic Maps 1:20 000, <http://www.geo-spatial.org/download/planurile-directoare-de-tragere>, (accessed 23 February 2017); Soviet Topographic Maps 1:50 000, <http://www.geospatial.org/download/hartile-sovietice-50k>, (accessed 2 February 2017).

## 1.5. Methodology

In the first part of my investigation, I created a database in QGIS<sup>25</sup>, where I stored spatial information about each archeological site. For establishing the coordinates of each site, I used a combination of methods. The standard one consisted of reading the literature describing their whereabouts, but it was the least helpful, since they were usually located through toponyms. The drawings provided in the written reports proved more useful however, for it was possible to georeference them in QGIS over topographic maps or contour levels derived from digital surface models. In addition to that, I also imported satellite imagery from Google Earth into the GIS to locate the sites more precisely via remote sensing. However, in some areas the locations were entirely covered by vegetation. In those cases, the sites are likely to have positioning errors up to 100 m. In examples where dense vegetation is absent, the error is likely to be somewhere between 5-20 m, or up to 50 m where the site extents were harder to trace in the satellite imagery due to poor resolution. In a couple of cases, aerial photographs also proved useful for finding sites that are harder to spot nowadays. It is important to note that the positioning errors impacted the obtained results depending on how severe they were.

To validate my findings, I also tested a sample of sites by field walking on the 4th and 8th of August 2016. On that occasion, photographs were taken, as well as coordinates acquired with a differential GPS using the GPS Coordinates Finder mobile application.<sup>26</sup> The complete state of each site is presented in the 6.2. List of plates from the Appendices section.

Before doing any analysis however, I had to choose what dataset and observer heights to use. The choice was a sensitive one because both the quality of the dataset and the estimated heights would likewise impact the final results. There were three free datasets available for the studied area, but the decision was made after calculating the Root Mean Square vertical error for all three of them. That was followed by some visual and profile analyses as well. For determining the observer heights on the other hand, watchtower reconstructions had to be done by establishing a model based on various of sources. Blender was used for visually testing the results.<sup>27</sup> These two preliminary steps are documented in more detail in the 2.2. Preliminary work in the next chapter.

In the final part of my work, I focused my attention on the viewshed analysis. The approach I used consisted of a combination of binary and fuzzy viewsheds. It was accomplished in two GIS softwares, some operations being done in GRASS<sup>28</sup>, while others in QGIS. A more detailed description of the analysis is likewise provided in the 2.3. Workflow in the chapter below.

---

25 QGIS, <http://www.qgis.org>, (accessed 3 February 2017).

26 GPS Coordinates Finder, <http://www.eezgu.com/gps-coordinates-finder?i=1>, (accessed 23 February 2017).

27 Blender, <https://www.blender.org/>, (accessed 5 April 2017).

28 GRASS, <https://grass.osgeo.org/>, (accessed 5 April 2017).

## 2. GIS viewshed analysis

The following chapter represents the main section of my thesis, and is divided in four subchapters. In the first one, the theoretical framework is presented. Its purpose is to explain what type of analysis viewshed is, what it does, what its shortcomings are, and what is it good for. After that, the preliminary work necessary for carrying out the analysis is described. Next, the workflow is described step by step, whereas the last section contains the results of the analysis.

### 2.1. Theoretical framework

Geographical Information Systems (GIS) may broadly be defined as a software containing a collection of tools that allows acquiring, storing, managing, visualizing and analyzing spatially referenced data.<sup>29</sup> Since it was adopted in archaeology, some have considered it merely a toolbox, whereas others more as 'a place to think'.<sup>30</sup> For instance, Cowen described it as “a decision support system involving the integration of spatially referenced data in a problem solving environment”.<sup>31</sup> However, GIS use in archaeology was sometimes considered deterministic, reductionist, positivist and anti-historical.<sup>32</sup> Nevertheless, it found many uses in archaeology due to its advantages, viewshed applications being a typical example.

Viewshed analysis is a process where visibility between an observer point and a target one is determined automatically. The analysis is done on a digital elevation model (DEM), which is a grid containing cells with different elevation values meant to represent the topography of an area in a simplified and relatively accurate way. Viewshed works by projecting a straight line-of-sight from one point to another, and if all of the elevation cells fall below that line, then the two points become intervisible. The result is basically a raster layer, a grid containing but only two types of cells this time, one with values of 1 for visible areas, the other with 0 or null for areas that cannot be seen. This type of viewshed is formally called binary or single viewshed, and is obtained with push button ease. More complex viewsheds on the other hand require post-processing operations. Cumulative viewsheds for instance result from multiple single viewsheds summed together, and contain cells ranging from 0 to a theoretical maximum number of viewpoints, depending on the number of observer points that can see a particular cell.<sup>33</sup>

Visibility studies are nothing new in archaeology however. Non-GIS visibility analyses have also been done, especially before the popularization of this technique. Yet these examples of analyses were informal by nature and sometimes methodologically less well-defined. Although the opposite, GIS visibility analyses also have their own problems. Some of these are of ontological, epistemological, methodological or ethical essence, which are more

---

29 Conolly and Lake 2006, pp. 11-14.

30 Chapman 2006, pp. 14-15.

31 Kvamme 1999, p. 157.

32 Lock 1995, p. 16; Lock 2001, pp. 156-160.

33 Conolly and Lake 2006, pp. 27-28, 226-228.

GIS rather than viewshed related. Other issues are of procedural type on the other hand.<sup>34</sup> One problem is reality-based, meaning that viewshed analysis results depend on data quality (type of DEM - digital terrain model vs digital surface model, but also DEM resolution), operational assumptions (height of the observer point) and choice of algorithm (implemented slightly differently in each software). Other procedural problems are related to the edge-effect (truncated viewshed layers if the map area is smaller than the radius), reciprocity (if the height difference between observer and target offset is higher then intervisibility may not occur both ways), robustness and sensitivity (different height parameters may alter the visible area noticeably), significance (lack of quantitative rigour), undifferentiated nature (results portrayed in terms of black and white), object-background clarity and acuity of vision (not taken into account by default and hard to implement).<sup>35</sup>

These procedural problems are solvable however, only some to a greater extent than others. Problems related to the undifferentiated nature of viewsheds for instance were experimentally addressed by dividing the field-of-view into multiple visual ranges, or by incorporating fuzzy set theory into the representation. Both approaches proposed incorporating a probabilistic element into the model to obtain a type of constantly diminishing field of view. Higuchi viewsheds use a visual index of distance to break down the standard binary viewshed into a set of visual ranges to assess the degree and types of visible objects. Yet the limits of these visual ranges were established based on observations conducted on trees.<sup>36</sup> Fuzzy viewsheds modify the standard viewshed by using fuzzy set theory in combination with a distance decay function. In this case, the clarity of objects found within the range closest to the observer ( $b1$ ) is assumed to be perfect ( $= 1$ ), whereas for those within the next range ( $b2$ ) it decays with distance ( $d$ ) to the point where the fuzzy membership ( $\mu$ ) reaches 0.5 (Figure 4). The clarity of anything found outside this range further decreases quickly to the point where it becomes completely invisible. This method was later modified to determine the length of the crossover point ( $b1 + b2$ ) by deducing the distance ( $d$ ) past which an object of a given size ( $s$ ) subtends a certain visual arc ( $\beta$ ) (Figures 5 and 7). However, it was also proposed to decrease the fuzzy membership to somewhere below 0.4 to obtain a less steep and more realistic drop-off (Figure 6).<sup>37</sup> This example may represent a solution to object-background clarity and acuity of vision, because it allows the possibility to model visual ranges based on different visibility conditions (eyesight, weather, color of viewed object vs color of background, etc.) or research questions (recognition or detection) by experimenting with higher or lower visual arcs. However, such models can be very clearly established only through field experiments and observations, because the viewing ranges are rarely dependent on the size of the viewed object alone (eg. electrical wires and cables, nocturnal fires, flags, etc.).

---

34 Lake and Woodman 2003, pp. 690, 693-694.

35 Conolly and Lake 2006, pp. 228-232; Van Leusen 1999, pp. 218-219; Wheatley and Gillings 2000, pp. 5-10.

36 Wheatley and Gillings 2000, pp. 13-15.

37 Fisher 1999, pp. 200-202; Ogburn 2006, pp. 407-411.

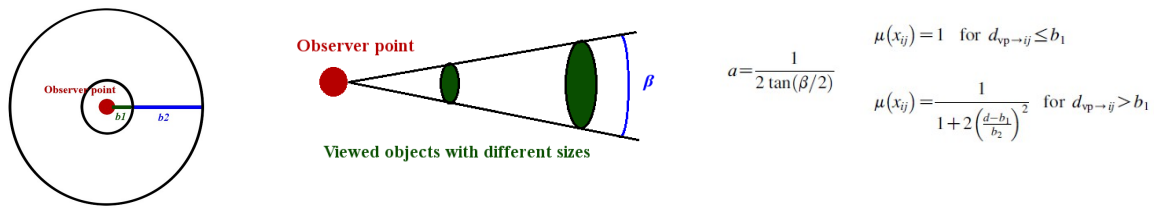

Figure 4. (top left) Ranges that model the distance decay in fuzzy views.  $b_1$  is the range within which everything is everywhere clearly visible.  $b_2$  is the distance from  $b_1$  to the crossover point, where visibility drops from 1 to 0.5, depending on how close or far is the target from the observer (Literature: Ogburn 2006, p. 409. Resources and tools: GIMP).

Figure 5. (top center) Relationship between distance and the size of the viewed objects measured in visual arc ( $\beta$ ). The closer the objects are to the observer the better their clarity. When they no longer meet the projected segments at any point, they subtend the angle, meaning that recognition ceases and detection comes into play (Literature: Ogburn 2006, p. 406. Resources and tools: GIMP).

Figure 6. (top right) Formulas showing how  $b_1 + b_2$  is determined based on the size of the viewed object, as well as how to obtain a target size-sensitive fuzzy membership. The first formula provides a distance multiplier  $a$  given a certain visual arc ( $\beta$ ), which is afterwards multiplied with the size of the viewed object ( $s$ ) to obtain  $b_1 + b_2$ . The second formula explains what the fuzzy membership ( $\mu$ ) should be within  $b_1$  and  $b_2$  for the decay function to work (Literature: Ogburn 2006, pp. 409-410).

Table 1  
Distance multipliers for several visual arcs

Visual arc	Distance multiplier	Distance at specified visual arc for object of width				Notes
		1 m	2 m	5 m	10 m	
30"	6880	6880	13,700	34,400	68,800	Limit of human recognition acuity and resolution acuity under ideal conditions of contrast and lighting. Limit of normal 20/20 vision.
1'	3440	3440	6880	17,200	34,400	
2'	1720	1720	3440	8600	17,200	Limit of Higuchi's middle-distance view. Limit of Higuchi's short-distance view.
3'	1150	1150	2300	5750	11,500	
1°	57	57	114	290	570	

Figure 7. Examples of crossover lengths ( $b_1 + b_2$ ) for objects with different sizes given different visual arcs (Literature: Ogburn 2006, p. 410).

There are some pragmatic problems that both GIS and non-GIS visibility studies share however. Some are related to the paleoenvironment/paleovegetation or the contemporaneity of different monuments, only that these issues are mostly determined by the level of knowledge and the archaeologists' ability to retrieve sufficient qualitative information. Sometimes theoretical considerations also come into play, like objective vs subjective view of geographical space, visibility vs perception, or cognitive aspects.<sup>38</sup> Nevertheless, such issues are also dependent on the researched topic, as well as the time period. Visibility studies conducted on fortifications and defensive systems are usually concerned with more pragmatic

38 Van Leusen 1999, pp. 218-220; Wheatley and Gillings 2000, pp. 4, 11-12.

theoretical considerations on the other hand. The large number of both non-GIS<sup>39</sup> and GIS<sup>40</sup> visibility studies done on Roman military installations prove the relevance of these methods' use. Despite all the shortcomings viewsheds and GIS overall have, they are advantageous in the sense that they provide quantifiable and more accurate, but not necessarily precise, assessments of visibilities or intervisibilities. Moreover, such analyses can be done from any theoretical heights, even if the structures are ill preserved or completely gone, after reconstructing their heights or simply by testing different hypotheses surrounding their heights. In an informal visibility analysis situation however, that would normally be harder to achieve, especially for/between sites located in forested areas. The viewshed results obtained from different sites may also be compared in the GIS environment to understand to what extent the different visibility maps overlap or complement each other. Lastly, such products may also be compared with spatial information obtained from other types of analyses or field surveys.

## 2.2. Preliminary work

First of all, matters related to dataset choice required some attention. There were three different free digital surface models (DSM) available for my study area: the 30 m resolution model acquired by the Advanced Spaceborne Thermal Emission and Reflection Radiometer (ASTER 1 arcsec)<sup>41</sup>, as well as the 30 m<sup>42</sup> and 90 m<sup>43</sup> resolution models acquired by the Space Shuttle Endeavor's Shuttle Radar Topography Mission (SRTM 1 and 3 arcsec). The Root Mean Square vertical error (RMSE) for all three datasets representing the study area was calculated by using the 1:50 000 Soviet topographic map for deriving a number of twenty observed values, and the following results were obtained: 7.506663706 m, 7.797435476 m and 11.65547082 m respectively. At this point, the ASTER and SRTM 1 arcsec datasets seemed to be the best choice, but the quality of the first one was occasionally debated in quality assessment publications.<sup>44</sup> A quick visual comparison between the two models showed that the ASTER displayed more noisiness in built-up areas (Figure 8). Moreover, a geological profile was randomly drawn across the map to examine the slope differences of all three datasets. The result showed that the ASTER also contained at least one raster cell with a missing value (Figure 9). Therefore, I eventually decided to use the SRTM 1 arcsec for the analysis instead. However, the RMSE for all three datasets is considered relatively high. It means that the results derived from them should be taken with more caution.<sup>45</sup>

39 Gudea 1985, pp. 143-158; Woolliscroft 1993, pp. 294-302; Zitterkopf and Sidebotham 1989, pp. 180-188.

40 Bell 1999, pp. 14-18; Driessen and Abudanah 2013, pp. 45-50; Marcu and Cupcea 2013, pp. 569-589; Marcu and Cupcea 2015, pp. 67-74; Teodor 2015, pp. 15-102.

41 ASTER Global DEM - 30 m, <https://doi.org/10.5067/ASTER/ASTGTM.002>, (accessed 19 February 2017).

42 SRTM Global DEM - 30 m, <https://lta.cr.usgs.gov/SRTM1Arc>, (accessed 4 April 2017).

43 SRTM Global DEM - 90 m, <http://www.cgiar-csi.org/data/srtm-90m-digital-elevation-database-v4-1>, (accessed 22 February 2017).

44 Forkuor and Maathuis 2012, pp. 235-236; Guth 2010, p. 9; Suwandana et al. 2012, p. 2429.

45 Fisher 1995, pp. 527-530. When using coarse resolution datasets or DEMs with higher RMSE, it is ideal to generate probable viewsheds as well. Their purpose is to assess to what extent the visible cells are so 'by chance'. However, due to time constraints I was unable to include them in this study.



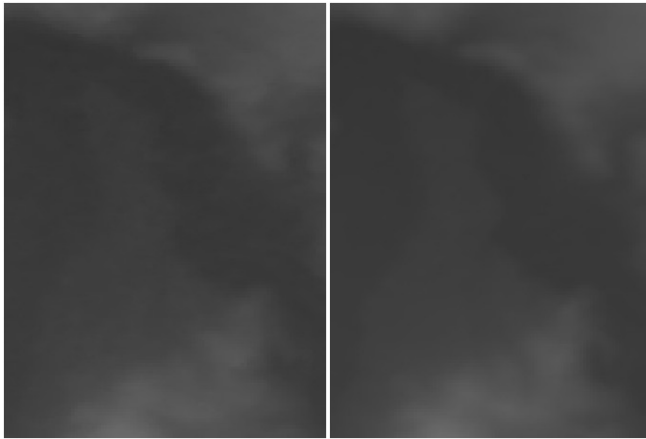

Figure 8. Visual comparison between ASTER 1 arcsec (left) and SRTM 1 arcsec (right) showing the noisiness (Resources and tools: ASTER Global DEM - 30 m; SRTM Global DEM - 30 m; QGIS).

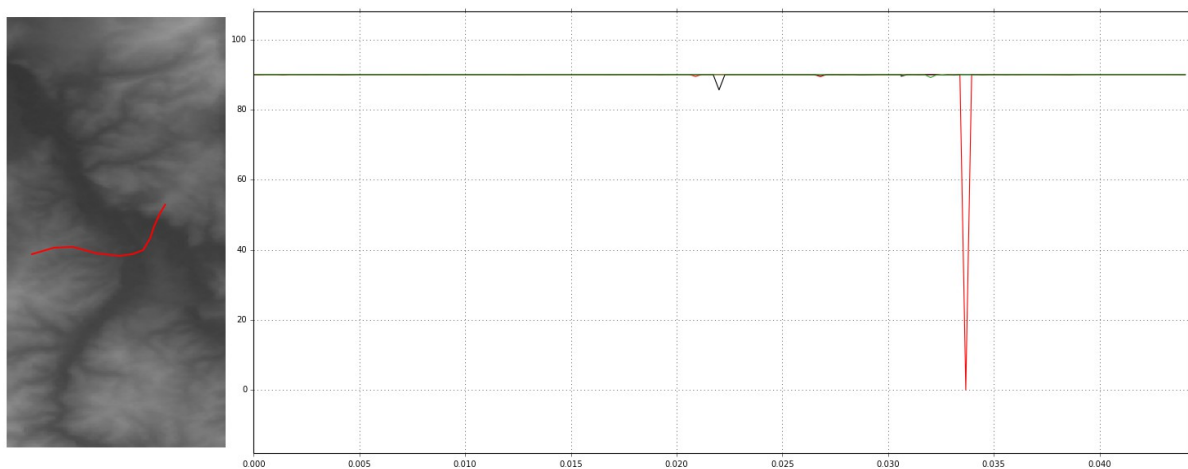

Figure 9. Geological profile showing the slope difference, where ASTER 1 arcsec is red, SRTM 1 arcsec black and SRTM 3arcsec green (Resources and tools: ASTER Global DEM - 30 m; SRTM Global DEM - 30 m; SRTM Global DEM 90 m; QGIS).

Secondly, to establish the height parameters, the watchtower heights needed to be estimated. Since the sites themselves are very badly preserved nowadays, the structures had to be reconstructed using a variety of sources.

Direct evidence describing the appearance of these buildings can be found in the excavation reports written during the 70's and 80's. At that time, the undisturbed sites looked like cone-shaped ruins with sunken tops and with trees growing in the interior. No certain signs of ditches running around the structures, entrances or stairs were found during the excavations. Common finds included tile remains, especially at sites closer to the auxiliary fort. That might suggest that the roofs were covered with tiles in some cases, other times with wooden shingles. Burnt layers also occurred very often, and were probably the roof or platform/balcony remains. Apparently, all known buildings were made of local stone, but at some sites the material appeared more abundantly than at others. This might indicate the existence of structures with only stone foundations and wooden superstructures, or it could

also be the result of stone robbing activities. Timber watchtowers were not documented with certainty in this study area, although installations sometimes are known to have had a wooden phase followed by a stone phase on the Germanic *limes* for example. In this study area, a similar phenomena probably occurred with Watchtowers 3a and 3b, the former being the younger one. In terms of dimension, the structures were classified by Gudea into small (3/4-5 m), medium (5-7 m), large (7-10/11 m). Their height varied depending on how well preserved each were, Watchtowers 4 and 7 being no taller than 0.8 and 1 m respectively, whereas Watchtower 1 reached almost 2 m. All walls were constructed in *opus incertum*, with varying amounts of mortar. Their thickness ranged between 0.8 and 1 m, usually depending on the size of each structure. Sometimes the foundations were 0.2 m thicker than the upper parts, but other times that was not the case. Their depth was usually around 0.4-0.45 m.<sup>46</sup>



Figure 10. Representations from Trajan's (first two) and Marcus Aurelius' (last one) columns (Trajan's Column photo A, Trajan's Column photo B, Marcus Aurelius' Column photo).

In other parts of the Empire, fully preserved watchtowers are also absent.<sup>47</sup> One of the few sources showing their appearance are the iconographic representations from Trajan's and Marcus Aurelius' columns (Figure 10). Although they are depicted with two storeys there, their representation is not uniform, because they appear with two types of roofs (with and without gables), and the observation platforms/balconies are sometimes absent. Moreover, the iconographic scales and proportions also differ. While their representations definitely point towards ratios above 1:1, it is hard to tell if the proportions they seem to indicate (1:2, or perhaps even more) are accurate or artistic. Additionally, estimating ratios from such representations can also be tricky because they are shown from perspective view. Therefore, watchtowers that had been reconstructed so far were always based on estimations. Dietwulf Baatz for instance estimated the tower heights at 7.6-10 m, supposedly equally segmented into storeys, depending on intervisibility with the neighboring ones.<sup>48</sup> Yet in iconography, they usually appear with only two storeys. Robert van Dierendonck estimated the total height of a

46 Gudea 1971, pp. 509-519, 527-528; Gudea 1985, pp. 156-157.

47 For example the Germanic *limes* from the Baden-Württemberg section. Te Vehne 2004, <http://www.limesseiten.de/LIMES/TUERME.HTML>, (accessed 6 April 2017).

48 Baatz 1976 cited in Van Dierendonck 2004, p. 80 and Marcu and Cupcea 2015, p.73. Linge 2012, [https://de.wikipedia.org/wiki/Datei:201206161804b\\_Wp\\_10-9\\_Infotafel.jpg](https://de.wikipedia.org/wiki/Datei:201206161804b_Wp_10-9_Infotafel.jpg), (accessed 6 May 2017). The estimations were deduced when examining watchtowers WP. 10/8 and WP. 10/9 from the Germanic *limes*. Considering there was a ridge between the two structures, both should have been at least 7.6 m tall in order to be intervisible. Their dimensions were around 5.8 x 5.8 m, which would indicate ratios above 1:1.3.

wooden watchtower from Valkenburg from its ground plan by considering a 1:2.5 ratio.<sup>49</sup> Tyler Bell did the same for reconstructing the height of a possible fourth century signal station from Whitby, but he opted for a ratio of 1:3. A fully preserved tower-like structure with the same ratio from the Roman Age is the La Coruna lighthouse, and its height is 45 m. Similar looking buildings, but known from historical sources, are Boulogne's Tour d'Order and the Alexandria Pharos, with ratios of 1:3.1 and 1:4.3 pointing to total heights of 61 m and 130 m respectively.<sup>50</sup> Yet these structures were lighthouses built primarily for acting as tall markers rather than observation posts. Military structures used for defence or observation usually seem to have been shorter. For example, cities from Roman Gaul like Le Mans, Senlis, Bourges and Carcassone have walls that rise up to 6 m. In some cases their towers retained one or two fully preserved storeys standing above the parapet walk. Their full height was therefore possible to estimate at 15-20 m.<sup>51</sup>

In light of this, reconstructing the watchtower heights necessitated drawing some assumptions. First of all, there was a higher variation between the length or diameter of the walls than between their widths. Smaller structures had foundations almost as thick as the larger ones. That might mean that higher ratios would have applied to the latter. Although the watchtowers appearing in the iconographic sources are disproportionately represented, they indicate that ratios above 1:1 would very likely have been used in reality. Secondly, the depictions also show that the structures very commonly had two storeys. However, it is difficult to say if the storey heights were unequally distributed due to stylistic reasons, or due to accuracy. Thirdly, the skill and knowledge of these builders is debatable to say the least, yet it is likely that they would have relied on knowledge gained from observations, but also from previous experiences. This means that they might have aimed for lower heights for safety reasons, but in some cases they might have taken greater risks too. It is known for certain that the walls of these structures were 0.8-1 m thick, and that the masonry was built in *opus incertum* with local stones bonded with Roman mortar. Modern-day building regulations for example would recommend 9.6-12 m maximum heights for similarly thick masonry constructed in uncoursed stone, but bonded with modern mortar.<sup>52</sup> However, such regulations are usually established by quantitative means to guarantee the stability of constructions by taking into account various conditions. Nevertheless, such heights were probably realistic. Some of the watchtowers might have reached heights below the modern recommendations, but others might have exceeded them somewhat. However, those rising vastly above 12 m might have become unstable. Therefore, very likely none of them would have exceeded 15 m I believe.

To reconstruct the heights, I took into account various sources, but a lot of importance was given to the iconographic representations seen above. As a primary condition, ratios above 1:1 were used to estimate the full heights, and to determine the lower limits of these

---

49 Van Dierendonck 2004, p. 84.

50 Bell 1998, pp. 314-316.

51 Butler 1983, p. 128.

52 The Build. Reg. 2010, s2C6 and 2C7. Used in England, it applies to solid external walls of residential structures shorter than 15 m (roof included), with no more than three storeys, and with walls no longer than 9-12 m length. The masonry should be at least 1.33 times 1/16 of the storey height.

reconstructions. I understand by full height the length measured from the base to the highest point, which would include the roof too in this case. To determine the upper limits however, the number of storeys depicted in iconography (two) was used as a secondary condition. In terms of design, I opted for roofs without gables, because these types are known to be more resistant to stronger winds. It is reasonable to believe that such winds would have occurred frequently on these hilltops, especially in the colder seasons. To deduce the level of the observation platform on which the guards would have stood ( $V$ ), I needed to deduct the height of the roof ( $HR$ ) and the height of the final storey ( $SH$ ) from the full height ( $FH$ ):  $V = FH - HR - SH$ .

For the height of the final storey ( $SH$ ), 3 m was considered. Vitruvius for example described some siege towers, mentioning their full heights and the number of storeys they had. In those cases, the height of one storey was 2.7 m.<sup>53</sup> When it comes to more permanent structures, some of the Gallo-Roman cities for instance had towers with fully preserved storeys, where the rooms were at least 3 m tall.<sup>54</sup> Here, it is unclear if all the storeys were equally high, or if their heights were equally distributed, yet 3 m was chosen to represent the average height of one storey.

Deducing the height of the roof ( $HR$ ) was more complicated. In historical sources, there is no information for military structures unfortunately. In his description of temple proportions, Vitruvius said the height should be 1/3 of the length of the complete roof for temples built in Tuscan style.<sup>55</sup> However, he did not specify how long the complete roof should be. For these towers, in order to cover the entire structure, including the platform/balcony if there was one, the length of the complete roof should be at least 3/5 of the width of the entire construction ( $W$ ):  $HR = W * 3 / 5 / 3$ . For technical reasons mostly dependent on weather conditions, tile roofs for example should have had an inclination of at least 10°, but no more than 30°.<sup>56</sup> With this setting, the roof of each reconstructed watchtower produced an approximate inclination of 22°. The width of the entire construction viewed from one side ( $W$ ) was obtained by adding the width of the balcony to the width of the base ( $S$ ), the latter being known from the archaeological reports. Since the balcony would have been used as an observation platform and a walkway, it had to be of a certain width. Vitruvius for example believed that walls of fortified towns should be as thick as to allow guards pass one another without interference. The same author also stated that in human proportions, the width of the human body should be ideally 1/4 of the entire height.<sup>57</sup> For the height of a guard, I considered 1.77 based on Vegetius' account of what the recommended height of soldiers serving in the cavalry and the first legionary cohorts was.<sup>58</sup> Therefore, the width of the entire construction was  $W = S + 4 * 1.77 / 4$ .

---

53 Vitruvius, 10.13. 4-5.

54 Butler 1983, p. 128.

55 Vitruvius, 4.7.5.

56 Gerding 2013, p. 142.

57 Vitruvius, 1.5.3; 3.1.2.

58 Vegetius, 1.5.

The full height ( $FH$ ) was obtained by applying the ratio ( $R$ ) to the width of each structure's base ( $S$ ):  $FH = S * R$ . A minimum ratio of 1:1.1 was considered as a primary condition for each structure, but since the smaller towers would have ended up with less than two storeys, a higher ratio was applied to those. Therefore, the number of storeys depicted in iconography was used as a secondary condition. Overall, the ratios that were used ranged between 1:1.1 and 1:1.5 depending on the width of each structure. They were chosen in such way as to produce as closely as possible the number of storeys seen in representations. The proportions gave heights that were below the ones recommended by modern-day building regulations in some cases (9.6-12 m), whereas for others they were somewhat above, but not excessively (Figure 11 and Table 1). However, these theoretical guidelines should normally only serve as a general reference. The reconstructed heights do not claim to represent real values. The reconstructed watchtowers are nothing but simplified models meant for simulating a system to understand their possible use and importance.

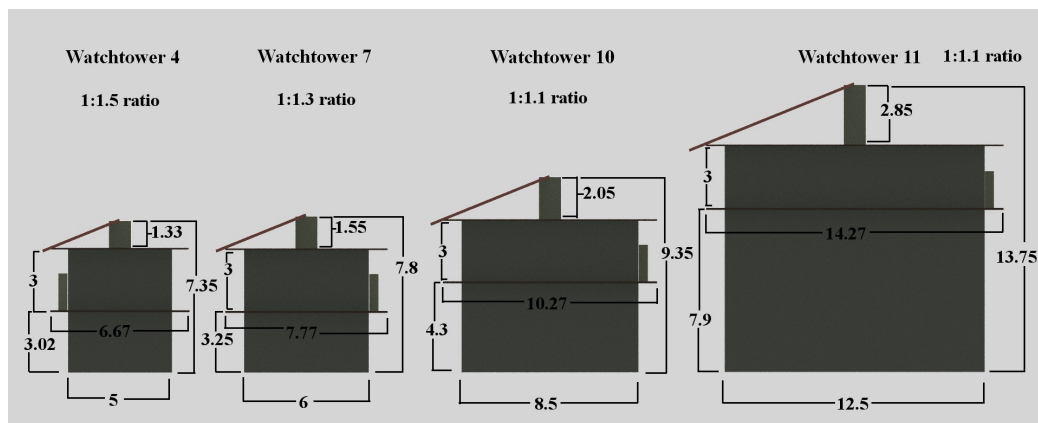

Figure 11. Examples of reconstructed watchtowers (Resources and tools: Blender; GIMP).

Watchtowers	Masonry widths	Theoretical maximum recommended heights	Side or diameters ( $S$ )	Ratio multiplier ( $R$ )	Estimated full heights ( $FH = S * R$ )	Estimated width of the entire structure ( $W = S + 4 * 1.77 / 4$ )	Estimated height of the roof ( $HR = W * 3 / 5 / 3$ )	Estimated storey height ( $SH = 3$ )	Estimated observation platform level ( $V = FH - HR - SH$ )	Estimated number of storeys
Watchtower 1	0.95	11.43	7.5	1.1	8.25	9.27	1.85	3	3.4	2.13
Watchtower 3a	0.85	10.23	5.6	1.4	7.84	7.37	1.47	3	3.37	2.12
Watchtower 3b	0.9	10.83	5.5	1.4	7.7	7.27	1.45	3	3.25	2.08
Watchtower 4	0.8	9.62	4.9 m (average)	1.5	7.35	6.67	1.33	3	3.02	2.01
Watchtower 5	0.87	10.47	5.25	1.5	7.88	7.02	1.4	3	3.47	2.16
Watchtower 7	0.87	10.47	6	1.3	7.8	7.77	1.55	3	3.25	2.08
Watchtower 8	0.95	11.43	7.8	1.1	8.58	9.57	1.91	3	3.67	2.22
Watchtower 10	1	12.03	8.5	1.1	9.35	10.27	2.05	3	4.3	2.43
Watchtower 11	1	12.03	12.5	1.1	13.75	14.27	2.85	3	7.9	3.63
Watchtower 12b	0.9	10.83	6	1.3	7.8	7.77	1.55	3	3.25	2.08

Table 1. Results of the reconstructed heights (in meters).

### 2.3. Workflow

The analyses I did in this study include binary, cumulative and fuzzy viewsheds. In each case, only the watchtowers with known dimensions were used as observer points. The viewing heights seen in Table 1 from 2.2. Preliminary work, which represents the height of the viewing platform (*V*), were applied to each corresponding structure. The SRTM 1 arcsec DSM was polygonized first, in order to manually add the viewing heights to the elevation values of the raster cells that spatially corresponded to the location of each reconstructed watchtower. Unfortunately, I had to round the numbers up (eg. 3.4 = 3 m or 3.67 = 4 m) to fit into the dataset. Nevertheless, that did not impact the results significantly. After converting the dataset back into raster format, it was used to determine the intervisibility between each of the cells with towers and any other raster cell, whether it contained a similarly raised construction or not.

All single viewsheds were carried out in GRASS GIS with the `r.viewshed.cva` module, where 1.7 m was considered for both the observer and the target height. This means that from each watchtower a visibility analysis was simulated from the height of a guard standing on top of the observing platform, in order to establish whether targets with similar size located on other observing platforms and/or in the field were visible or not. A maximum visual range of 16 km was computed in each case, because the maximum distance between any of the reconstructed towers and all the other sites from this study area was around 15 km. The curvature of the earth (ellipsoid) and the effect of the atmospheric refraction were also taken into consideration every time to simulate the errors they usually produce. The analyses were done in the WGS84 coordinate reference system.

Overall, the binary viewsheds were useful for understanding how well-placed the watchtowers were in relation to each other. That was indicated both qualitatively and quantitatively by the visible portions of land. Single viewsheds helped analyze the intervisibility to understand the local defensive systems' inherent visibility network. That aspect revealed if transmitting visual signals between different sites could have been possible, but also how this may have contributed to the functioning of the entire defensive system. However, it is worth noting that some of the sites from this area were better known or more certain than others. Those considered extremely uncertain (0) were left out in this study. In the 6.1. List of sites from the Appendices section, it is fully explained on what basis this classification was done. Moreover, some watchtowers could not be analyzed, because estimating their heights was not possible for reasons of insufficient knowledge. This not only meant that viewsheds could not be performed from those locations, but also that target heights of only 1.7 m were applied to those by default. As a result, at some sites intervisibility might have occurred less frequently or not at all (Fortlets 4 and 7). Additionally, it is also possible that unknown sites might still lie buried in some places. It was expected that all of these shortcomings would also affect the outcome of the analysis.

After all binary viewsheds were computed, a cumulative viewshed was also obtained in QGIS's raster calculator by summing up all the results into one raster layer. The purpose of this was to examine whether there were any serious visibility gaps between each pair of

watchtowers or not. In this case, the contrary would normally be expected from a typical linear defensive system. Cumulative viewsheds were also useful to determine what areas were visible from multiple spots at the same time. If certain raster cells were visible many times from different location, they might indicate a chronological sequence. However, the number of times particular areas are seen from multiple different positions may not always be entirely accurate. Visual ranges would normally fluctuate depending on various visibility conditions, which means that different ranges should be selected with different purpose in mind. In this case, the binary viewsheds obtained at 16 km ranges were used, which might have made some raster cells more times visible than they would have been in other situations. Due to time constraints, shorter single viewsheds were not computed solely for this application however.

The fuzzy viewsheds were done in QGIS by reclassifying the previously obtained binary viewsheds. In the first phase, the length of the crossover point ( $b1 + b2$ ) was calculated for an object of 1.7 m size with a visual arc ( $\beta$ ) of 1', which is considered to be the standard recognition limit of normal 20/20 vision under very good conditions. Furthermore, the calculations were repeated with visual arcs of 2' and 3' as well, in order to simulate viewing distances obtained under less favorable visibility conditions too. Ranges of 5.84, 2.92 and 1.94 km were acquired with 1', 2' and 3' visual arcs respectively. For the  $b1$  variable 1 km was usually proposed in the literature, but considering that 2' and 3' yielded shorter crossover points, I had to proportionally decrease it to 500 and 333 m respectively to obtain similar drop-offs. In all cases, a fuzzy membership ( $\mu$ ) of 1 was considered for  $b1$ , whereas for  $b2$  a value of 0.33 was used for visibility to decay to 0.33 at the crossover point. The model was applied through the use of multiple ring vector buffers created around each of the observer watchtowers, where the first ring represented  $b1$  (1000, 500 or 333 m long) and the next twenty segments  $b2$  (242, 121 or 80.5 m long each). After all the vector features were assigned their corresponding fuzzy memberships ( $b1 = 1000$ ;  $b2 = 966, 933, 900, \dots 333$ ) the file was converted into raster format. The final phase consisted of obtaining the fuzzy viewshed in the raster calculator by multiplying the raster buffers with the binary viewsheds, and then by dividing them with 1000.

The resulting fuzzy viewsheds were useful for establishing to what extent objects of 1.7 m size were visible in the landscape. In this case, the objects were meant to represent individuals standing on watchtowers or in any other place. For instance, individual targets positioned in a range of 1 fuzzy membership would have been relatively easy to recognize and distinguish from other objects, whereas those located at 0.5 might have been barely recognizable. For individuals present in any range with fuzzy memberships below the latter value, or for those that fell outside the threshold, detection rather than recognition would have more likely come into play. In this context, exploring recognition rather than detection was more relevant, because the functioning of a typical defensive system depends very much on the ability to tell friends from foes. However, in some situations detection might have been sufficient, if individuals traveling in suspiciously large numbers would have suddenly approached the *limes* for example.



## 2.4. Results

Watchtower 1 was the only structure from where the Auxiliary fort was visible in all of the viewsheds. Other visible sites included Fortlet 3 and Watchtowers 3a, 3b, 4, 5, 7, 8, 9, 10, 11. However, two other locations were relatively close to the nearest visible raster cells. For instance, Watchtower 2 was 1 m distant from the closest visible cell, while Fortlet 5 was 14 m away (Figure 12 and Table 3). The fuzzy viewsheds on the other hand produced fewer visible sites, as expected. With the 1' visual arc threshold, only the Auxiliary fort, Fortlet 3 and Watchtowers 3a, 3b, 4, 5, 7 could be seen. Interestingly, both the Auxiliary fort and Fortlet 3 stood within a fuzzy membership of 0.7. For all the others, except for Watchtower 7, the fuzzy membership was around 0.6-0.666 (Figure 13 and Table 3). With 2' visual arc on the other hand, only the Auxiliary fort was visible within a fuzzy membership of 0.333, which is the extreme limit of the threshold in this case (Figure 14 and Table 3). The 3' visual arc proved too strict because no sites fell within the threshold (Figure 15 and Table 3). The structure had a good overview of the surrounding area, but the view was largely restricted to the eastern, northern and western sides. On the eastern side, the area around the Auxiliary fort with the civilian quarter was entirely within range. The entire right bank of the Crișul Repede could be seen from this position, but only up to a range of 7 km northwest mostly. However, the view of the left bank was blocked by the steepness of the hill on top of which the tower was positioned. The area neighboring the right bank, which is north and west of Watchtowers 3a, 3b, 4, 5, 6, 7, 8, 10 and 11, consists of two valleys. Watchtower 1 could theoretically see the northern slopes of both valleys, especially the furthest one, but those areas were already relatively far. The southern and southeastern slope of the hill where Watchtower 2 was, also could be seen relatively well, but anything lying on the other side was out of sight. On the western side, mostly the left bank of Drăgan was visible up to a certain point, like in the previous situation.

Watchtowers 3a and 3b were probably from different phases. Due to their proximity, their intervisibility was not taken into consideration. Although close to one another, they seem to have had a slightly different role, but that might have not been the case. From Watchtower 3a it was possible to see Fortlet 3, but from Watchtower 3b the site was 45 m from the edge of the closest visible cell. Additionally, from Watchtower 3b it was impossible to see Watchtower 1 for some reason. Otherwise, they both shared the same visible sites: Watchtowers 2, 5 and 11, but the last tower could be seen only due to its relatively tall height. It is also worth mentioning that in the viewshed performed from Watchtower 3a, Watchtower 4 was 50 m away from the nearest visible cell, whereas from Watchtower 3b it was 75 m far (Figures 16, 20 and Table 3). The 1' visual arc fuzzy viewsheds produced the same number of visible sites as the binary ones. Fortlet 3 and Watchtowers 1, 2 and 5 fell within fuzzy memberships above 0.5, whereas for Watchtower 11 it was below that value (Figures 17, 21 and Table 3). With 2' visual arc however, Watchtowers 1 and 11 could no longer be reached, while Watchtower 2 was at 0.366 fuzzy membership (Figures 18, 22 and Table 3). With 3' visual arc, that also dropped out of sight, but Fortlet 3 and Watchtower 5 still remained above 0.5 fuzzy membership (Figures 19, 23 and Table 3). The two towers had roughly the same coverage,

except for the area north of Watchtower 1, which was not visible from Watchtower 3b. If that structure were higher, the results might have been different perhaps. It is worth noting that some portions of land were visible from these positions, whereas from Watchtower 1 they were not. Such was the case with the left bank of the Crișul Repede, the area north of Watchtower 1 and the remaining left bank of Drăgan. Both Watchtowers 3a and 3b could also see to a limited extent down the Vărădeștilor valley, especially its left bank, whereas Watchtower 1 could only see the right side of it. However, there was also some viewshed overlapping between these two structures and the previous tower to a certain extent (Figures 24 and 25).

Watchtower 4 could see Fortlet 3, Watchtowers 1, 2, 5, 7, 9 and 11. Watchtowers 3a and 3b were 13 and 25 m respectively from the nearest visible cells (Figure 26 and Table 3). The 1' visual arc fuzzy viewshed showed that Fortlet 3 and Watchtower 5 were within fuzzy memberships of 0.966 and 1 respectively. For the other sites on the other hand, the further they were, the lower their clarity (Figure 27 and Table 3). With 2' visual arc, only Fortlet 3, Watchtowers 5 and 7 fell within the threshold. However, the neighboring sites were visible within fuzzy memberships of 0.833 and 0.966, whereas Watchtower 7 was at 0.566 (Figure 28 and Table 3). With 3' visual arc on the other hand, only the former two were still visible to a decent extent (Figure 29 and Table 3). Watchtower 4's viewshed overlapped to a very high extent those of Watchtowers 3a and 3b. However, more land was visible in this case, mainly because the structure was placed around a 100 m higher. Technically, Watchtower 4 could fulfill the needs of the previous two structures to the same extent, if not even better. For example, complemented with Watchtower 1's viewshed, the entire left bank of Drăgan was fully visible now, and in the northern parts even the right bank was visible up to an additional 500 m. Moreover, Watchtower 4 could also see down, in the southern side of the Horhișului valley, which is immediately south of this structure. This may not be so relevant though, because the valley was basically behind the main line of defense. However, there was one potentially important difference between the previous pair of towers and this one. Watchtower 4 was able to see down the Vărădeștilor valley only on the northern side, like Watchtower 1, whereas the other two could see both sides. Both Watchtowers 1 and 4 were able to view the right bank of the Gârbului valley, west-southwest of Watchtowers 10 and 11. Although Watchtower 4 did so to a lesser extent, it was positioned closer to that valley (Figure 30).

Watchtower 5 had the potential to see Watchtowers 1, 2, 3a, 3b, 4, 6, 7, 9 and 11 (Figure 31 and Table 3). In the 1' visual arc fuzzy viewshed result, Watchtowers 3a, 3b, 4, 6 and 7 were visible at 1-0.933 fuzzy memberships. Watchtowers 1, 2 and 9 were at 0.633-0.6 on the other hand, whereas Watchtower 11 was at 0.533 (Figure 32 and Table 3). With 2' and 3' visual arcs, Watchtowers 1 and 2 dropped out of sight, but the other ones remained at fuzzy memberships of 0.966-0.733. The neighboring Watchtowers 4 and 6 were at similar fuzzy memberships, whereas Watchtowers 3a, 3b and 7 were further away. With 3' visual arc, Watchtower 7 dropped to a fuzzy membership of 0.533 however (Figures 33, 34 and Table 3). This structure had vision over a significant amount of land that was also visible from Watchtower 4. That was the case especially on the western side, where most of the left bank of Drăgan was visually shared with the previous tower. The same applied to the area north of Watchtower 1,

a significant portion of land on the northern side of the Gârbului valley, and the right bank of the Vărădeștilor valley. Nevertheless, Watchtower 5 could see both sides of the latter valley, complementing Watchtowers 3a and 3b's views. Moreover, from this tower, an extra amount of land was visible on the right bank of the Gârbului valley as well. Although this was shared with Watchtower 1, the first tower was again rather distant (Figure 35).

From Watchtower 7 it was possible to see Fortlet 3, Watchtowers 1, 2, 4, 5, 6, 8, 9, 10 and 11. Fortlet 5 fell 30 m outside the nearest visible cell (Figure 36 and Table 3). The 1' visual arc fuzzy viewsheds produced the same number of visible sites as the binary ones. Neighboring towers were visible at a fuzzy membership of 1, but Watchtower 5 was at 0.933. Watchtowers 4, 9, 10 were at 0.833-0.8, whereas Fortlet 3 and Watchtower 11 were both at 0.733. Watchtowers 1 and 2 were below 0.5, at 0.4 and 0.433 respectively (Figure 37 and Table 3). With 2' visual arc, the previous two structures dropped out of sight, while Fortlet 3 and Watchtower 11 were either close to or at the limit of the threshold. Watchtowers 4, 9 and 10 were visible at 0.566-0.466 fuzzy memberships, whereas Watchtower 5 was a closer, at 0.733 (Figure 38 and Table 3). With 3' visual arc however, the clarity of latter decreased at 0.533, while the neighboring Watchtower 6 and 8 were at 0.766 and 0.833 fuzzy memberships respectively (Figure 39 and Table 3). Watchtower 7's viewshed likewise overlapped the previous structures' to a large extent on the western side. The same applied to the area located on the northern side of the Gârbului valley. In both directions, only slightly more land was visible. This tower had some view of the eastern side as well, but that corresponded to friendly territory however. It was more significant that Watchtower 7 could view both sides of the the upper reach of the Vărădeștilor valley (Figure 40).

Watchtower 8 could see Watchtowers 1, 2, 7, 9 and 11 (Figure 41 and Table 3). With 1' visual arc, the same sites could also be visualized, but Watchtower 2 was at 0.366 fuzzy membership. The other sites were at fuzzy memberships of 1-0.8 on the other hand (Figure 42 and Table 3). In the 2' visual arc fuzzy viewshed, Watchtower 7 was at 0.933, Watchtower 9 at 0.666, and Watchtower 11 at 0.5 (Figure 43 and Table 3). With 3' visual arc, only Watchtowers 7 and 9 were within the threshold, but the former was at 0.833, while the latter at 0.433 (Figure 44 and Table 3). Watchtower 8 seemed to have had a relatively limited view of the surrounding land. Although portions of land located on the left bank of the Drăgan valley were again visible, as was the area north and east of Watchtower 2, the structure was already relatively distant in comparison with the previous ones. Watchtower 8 could see the remaining parts of the Vărădeștilor valley, both sides, by complementing Watchtowers 5 and 7's views (Figure 45).

From Watchtower 10, Watchtowers 1, 2, 7 and 11 were visible. Watchtower 8 was around 50 m from the nearest visible cell (Figure 46 and Table 3). With 1' visual arc, Watchtowers 7 and 11 were at 0.8 and 1 fuzzy memberships respectively (Figure 47 and Table 3). In the 2' visual arc however, Watchtower 7 was below 0.5 fuzzy membership, whereas in the 3' visual arc it dropped out of sight. Watchtower 11 on the other hand, was still visible with a certain measure of clarity (Figures 48, 49 and Table 3). From Watchtower 10, it was possible to see a fair amount of land southwest and east of the structure. It shared large areas on both sides with Watchtower 7, but like with Watchtower 8, those places were also rather distant.

Watchtower 10 could see the both sides of the Gârbului valley on the other hand. Watchtowers 7 and 8 could only do that for the northern side however (Figure 50).

Watchtower 11 was the only site that could see Fortlets 2, 5 and 6. From there, it was also possible to view Watchtowers 1, 2, 3a, 3b, 4, 5, 7, 8, 9 and 10 (Figure 51 and Table 3). With 1' visual arc, Fortlets 5, 6 and Watchtower 10 were at 1-0.966 fuzzy memberships. Watchtowers 8 and 9 were at 0.833-0.8 fuzzy memberships, while Watchtower 7 was further, at 0.733. The structures located even further, like Watchtowers 3a, 3b, 4 were below 0.5 fuzzy memberships, while Watchtower 5 was at 0.533 (Figure 52 and Table 3). In the 2' visual arc fuzzy viewshed, Fortlet 5 was still visible at fuzzy membership of 1, but Fortlet 6 and Watchtower 10 were at 0.833 and 0.866 respectively. Watchtowers 8 and 9 were at 0.5 and 0.566 on the other hand, whereas Watchtower 7 was at the extreme limit of 0.333 (Figure 53 and Table 3). With 3' visual arc however, only Fortlets 5, 6 and Watchtower 10 were within the threshold, at fuzzy memberships of 0.933, 0.666 and 0.733 respectively (Figure 54 and Table 3). At first glance, Watchtower 11 had an enormous view of the surrounding area, but its efficient range was more likely shorter. Within a 7.5 km range, most of the visible land was located to the east or west. Watchtower 11's viewshed overlapped those of Watchtowers 7 and 10 to a certain extent. Watchtower 11 could also see the right bank of the Lazului valley, west of Fortlet 6, up to and even beyond the Poic valley. It is also noteworthy that Watchtower 11's view was partially complemented with Watchtower 1's between a 2.5 and 5 km range from the structure. However, Watchtower 1 was already at 5-7 km distant from that area (Figure 55).

From Watchtower 12b only Watchtower 13 was visible. Fortlet 4 was 50 m away from the nearest visible cell however (Figure 56 and Table 3). In the 1' and 2' visual arc fuzzy viewsheds, Watchtower 13 was visible at fuzzy memberships of 0.933 and 0.733 respectively (Figures 57, 58 and Table 3). With 3' visual arc, it was at 0.5 fuzzy membership on the other hand (Figure 59 and Table 3). This tower also seems to have had a long range, like the previous one. Its viewshed overlapped Watchtower 11's on the eastern side significantly. On the western side, that occurred to a lesser extent. Moreover, this tower could only see beyond the Poic valley, whereas none of the areas found on the left bank were visible, except within a range of 2 km (Figure 60).

Overall, the obtained viewsheds displayed a high degree overlapping. That was especially the case with areas located far from the observer points. However, sometimes even areas close to the observers were in the same situation. The cumulative viewshed showed that the most frequently seen areas were the area south of Fortlet 3, the entire Vărădeștilor valley, the northern bank of the Gârbului valley, the left bank of the Drăgan valley, but also its right bank to some extent. Other areas could be seen from fewer different locations, or from only one, but that should not mean that they might have been of less interest. In many cases, the watchtowers' viewsheds complemented each others views, as was shown above. Visual gaps did not occur between towers, except in one place, between Watchtowers 11 and 12b. It is noteworthy that around 4-6 km west from the line of towers an almost continuous field of view existed however (Figure 61).

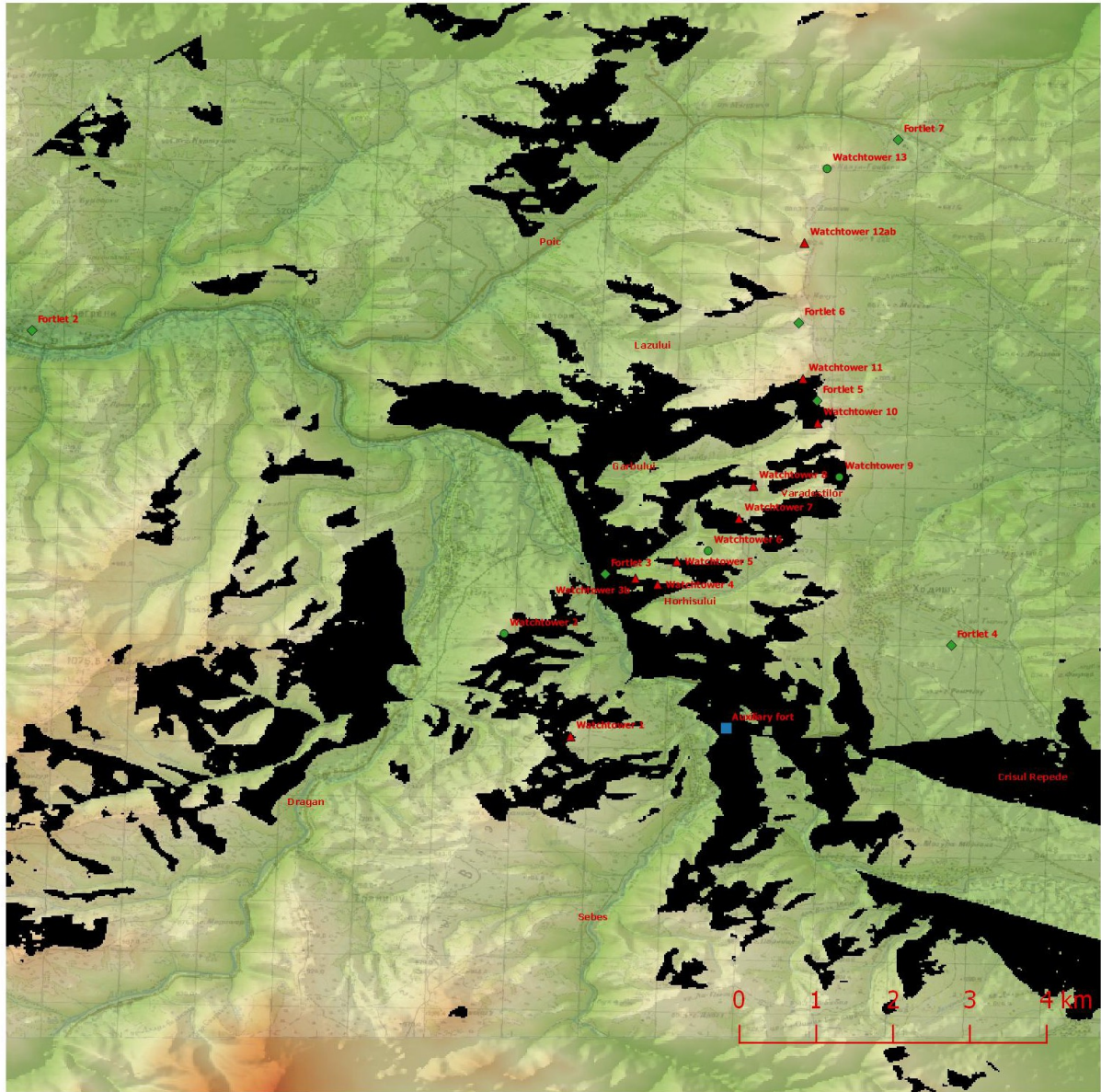

Figure 12. Watchtower 1 binary viewshed (Resources and tools: GRASS; QGIS; Soviet Topographic Maps 1: 50 000; SRTM Global DEM - 30 m).



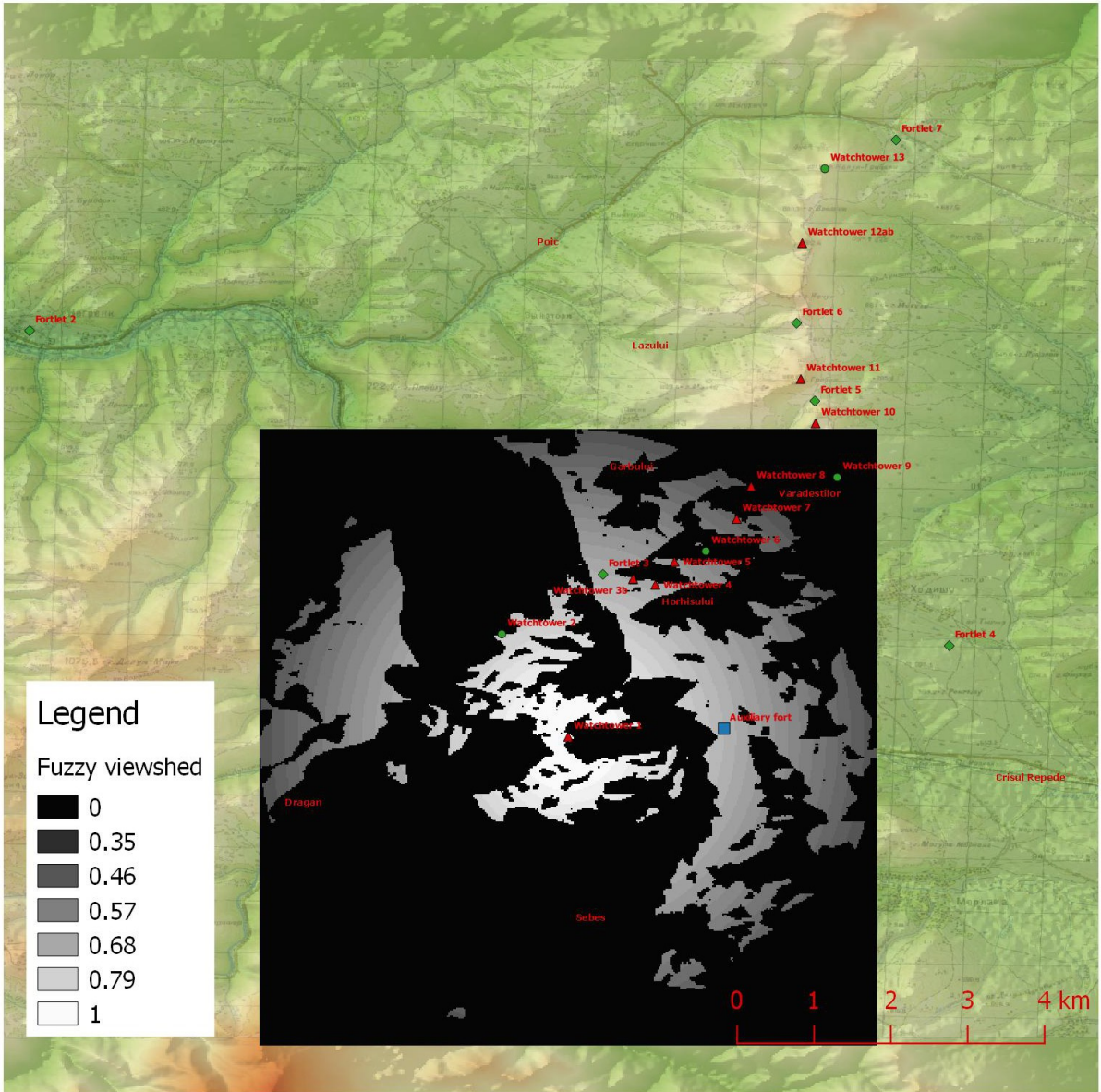

Figure 13. Watchtower 1 fuzzy viewedshed with 1' visual arc (Resources and tools: GRASS; QGIS; Soviet Topographic Maps 1: 50 000; SRTM Global DEM - 30 m).

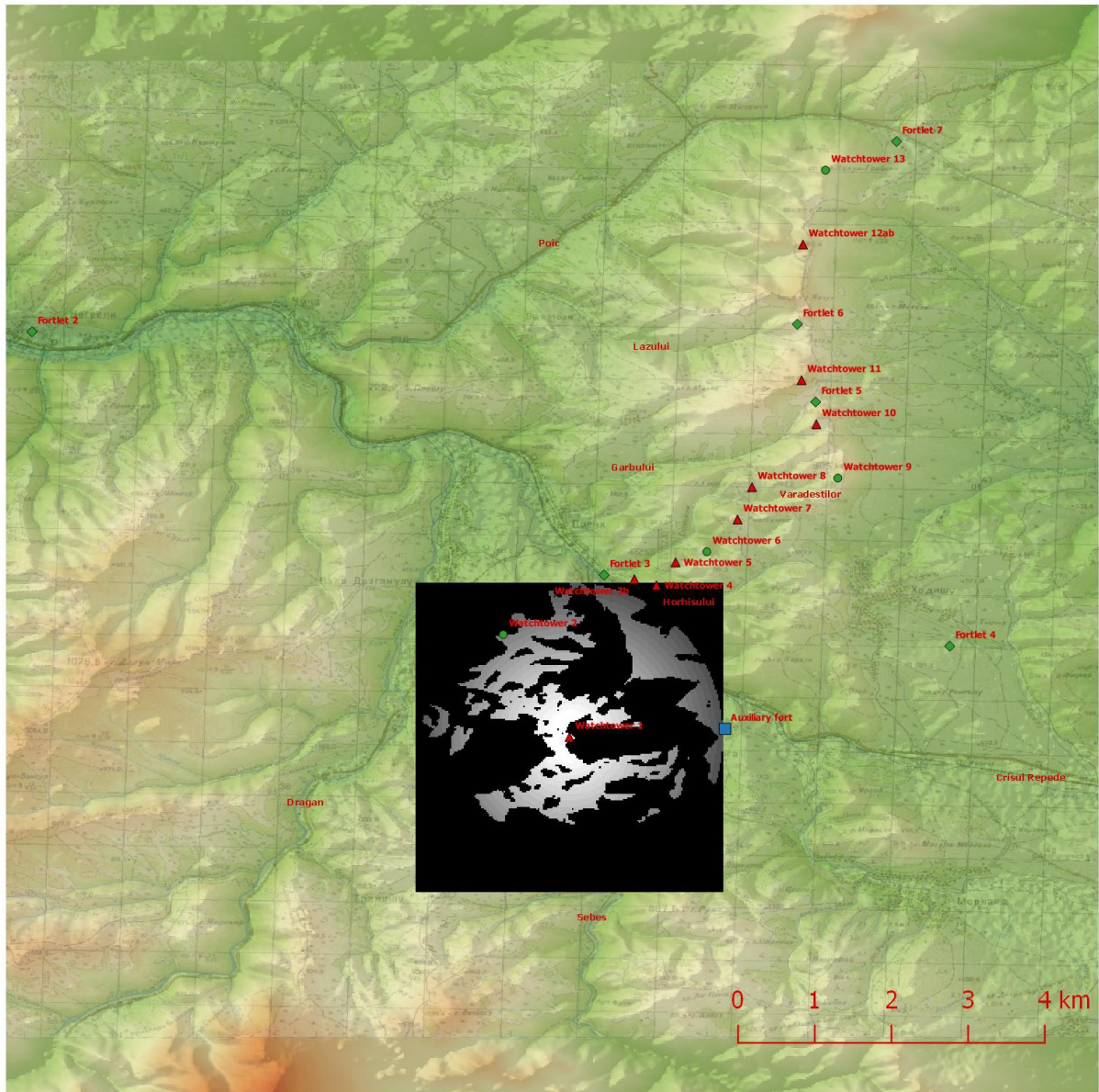

Figure 14. Watchtower 1 fuzzy viewshed with 2' visual arc (Resources and tools: GRASS; QGIS; Soviet Topographic Maps 1: 50 000; SRTM Global DEM - 30 m).



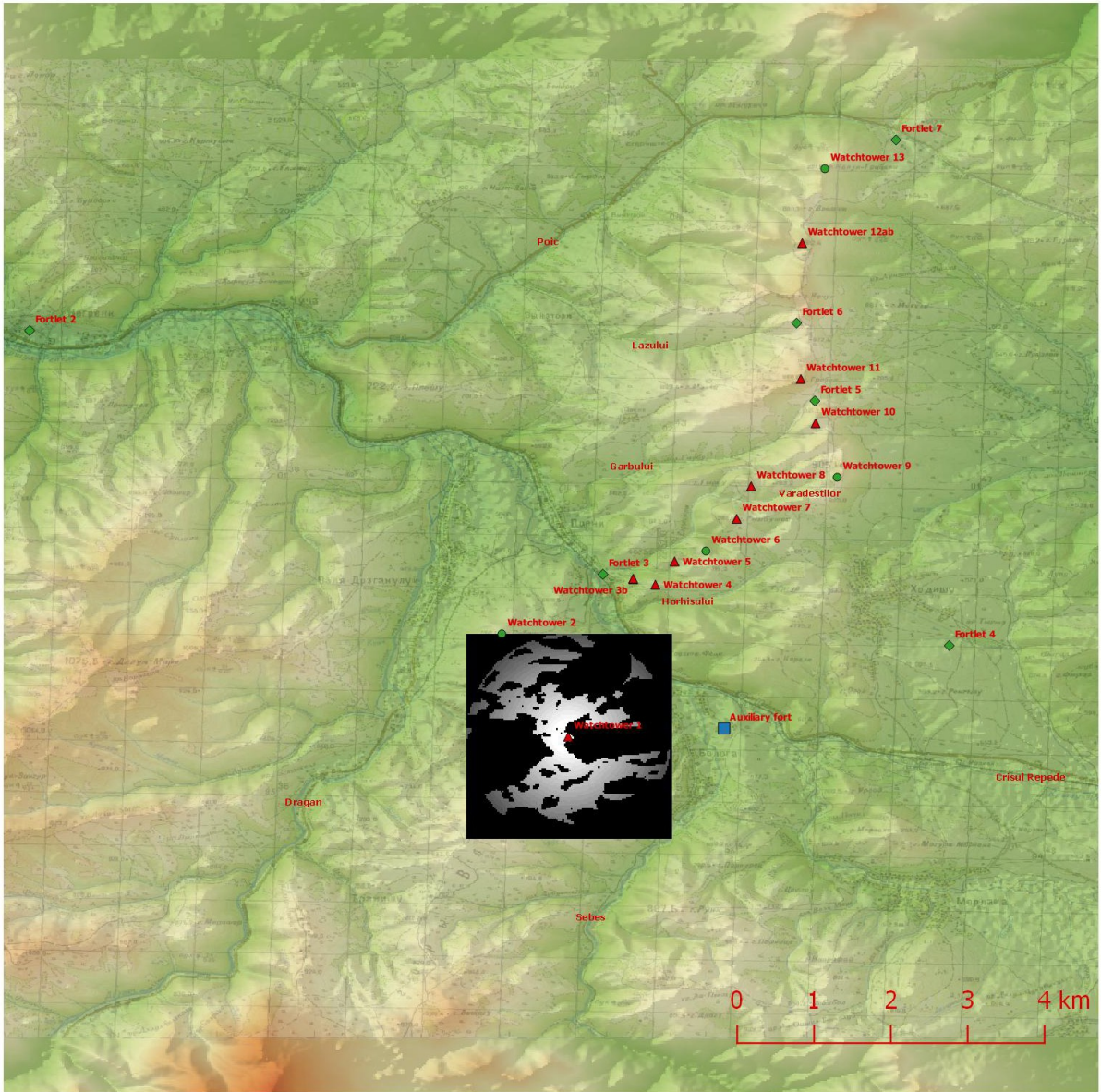

Figure 15. Watchtower 1 fuzzy viewshed with 3' visual arc (Resources and tools: GRASS; QGIS; Soviet Topographic Maps 1: 50 000; SRTM Global DEM - 30 m).



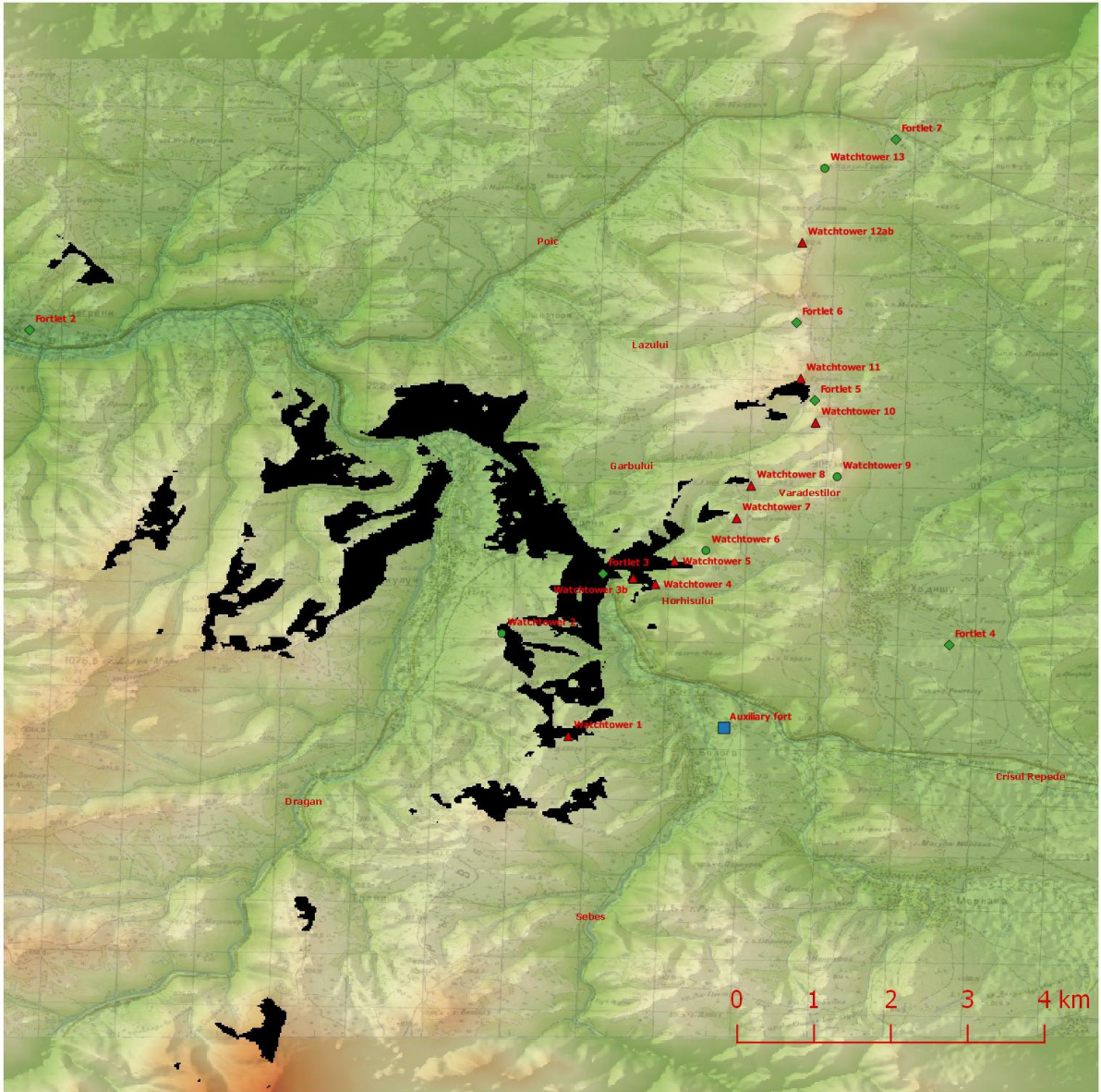

Figure 16. Watchtower 3a binary viewshed (Resources and tools: GRASS; QGIS; Soviet Topographic Maps 1: 50 000; SRTM Global DEM - 30 m).

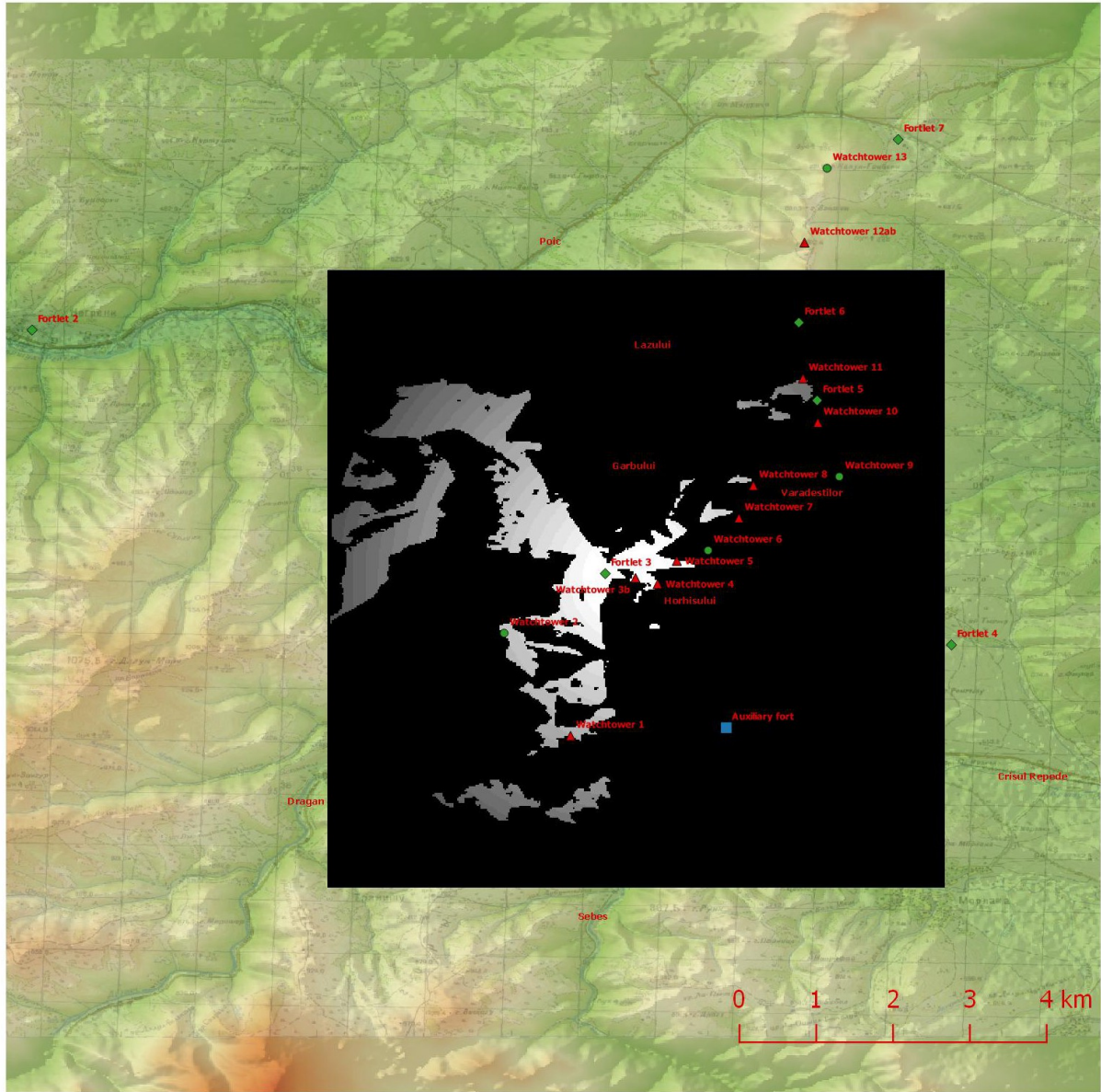

Figure 17. Watchtower 3a fuzzy viewshed with 1' visual arc (Resources and tools: GRASS; QGIS; Soviet Topographic Maps 1: 50 000; SRTM Global DEM - 30 m).



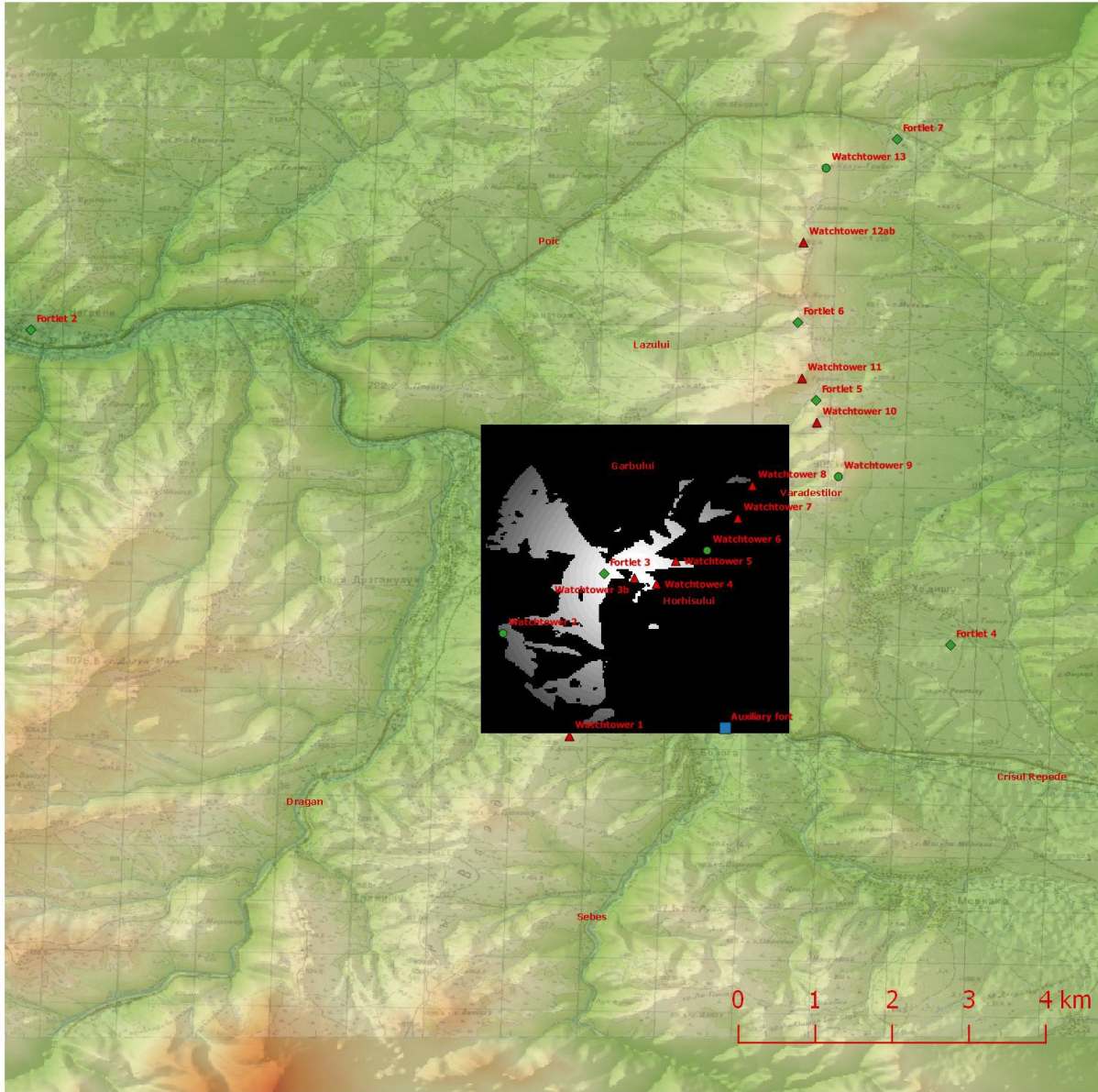

Figure 18. Watchtower 3a fuzzy viewshed with 2' visual arc (Resources and tools: GRASS; QGIS; Soviet Topographic Maps 1: 50 000; SRTM Global DEM - 30 m).



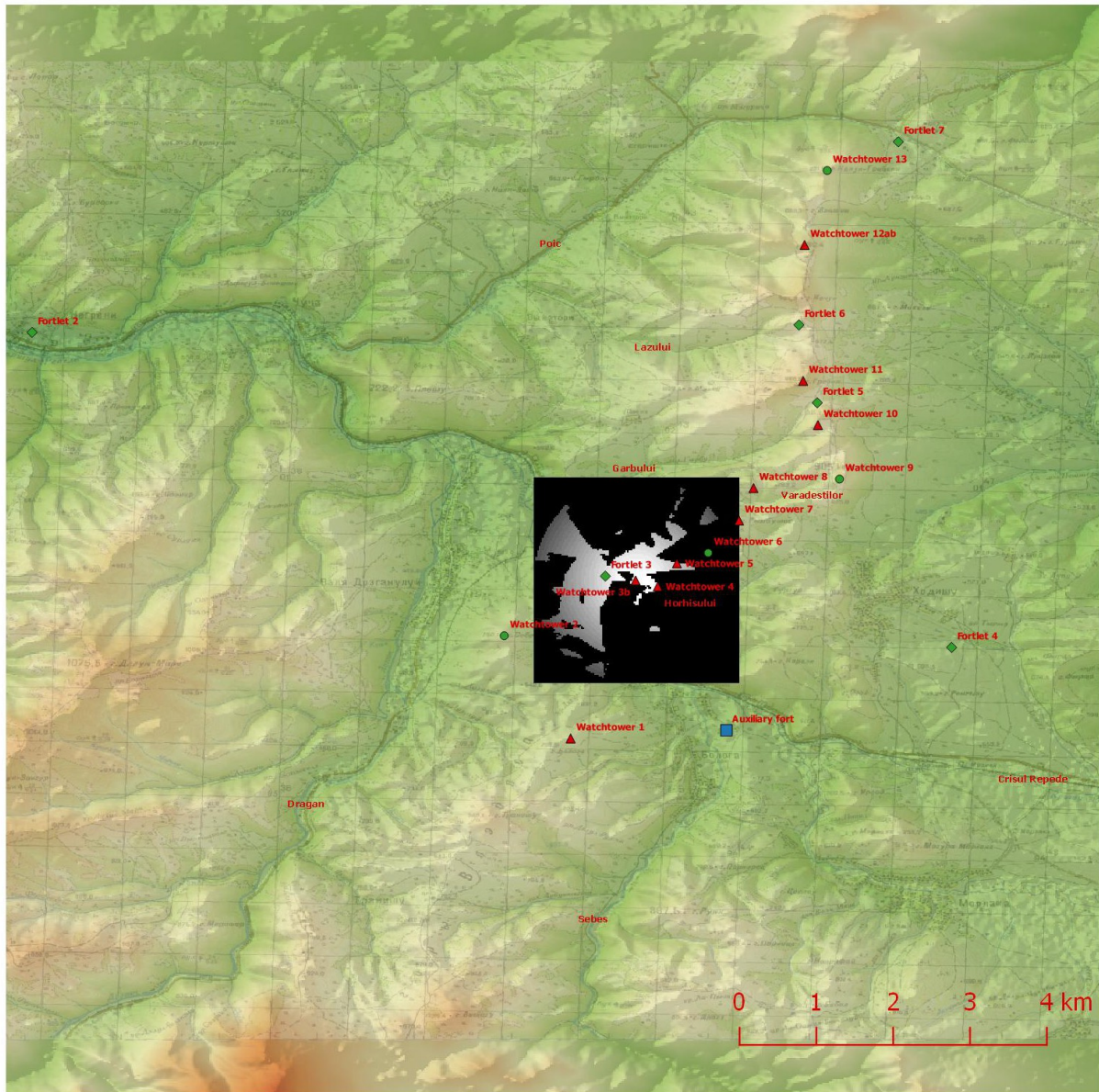

Figure 19. Watchtower 3a fuzzy viewshed with 3' visual arc (Resources and tools: GRASS; QGIS; Soviet Topographic Maps 1: 50 000; SRTM Global DEM - 30 m).



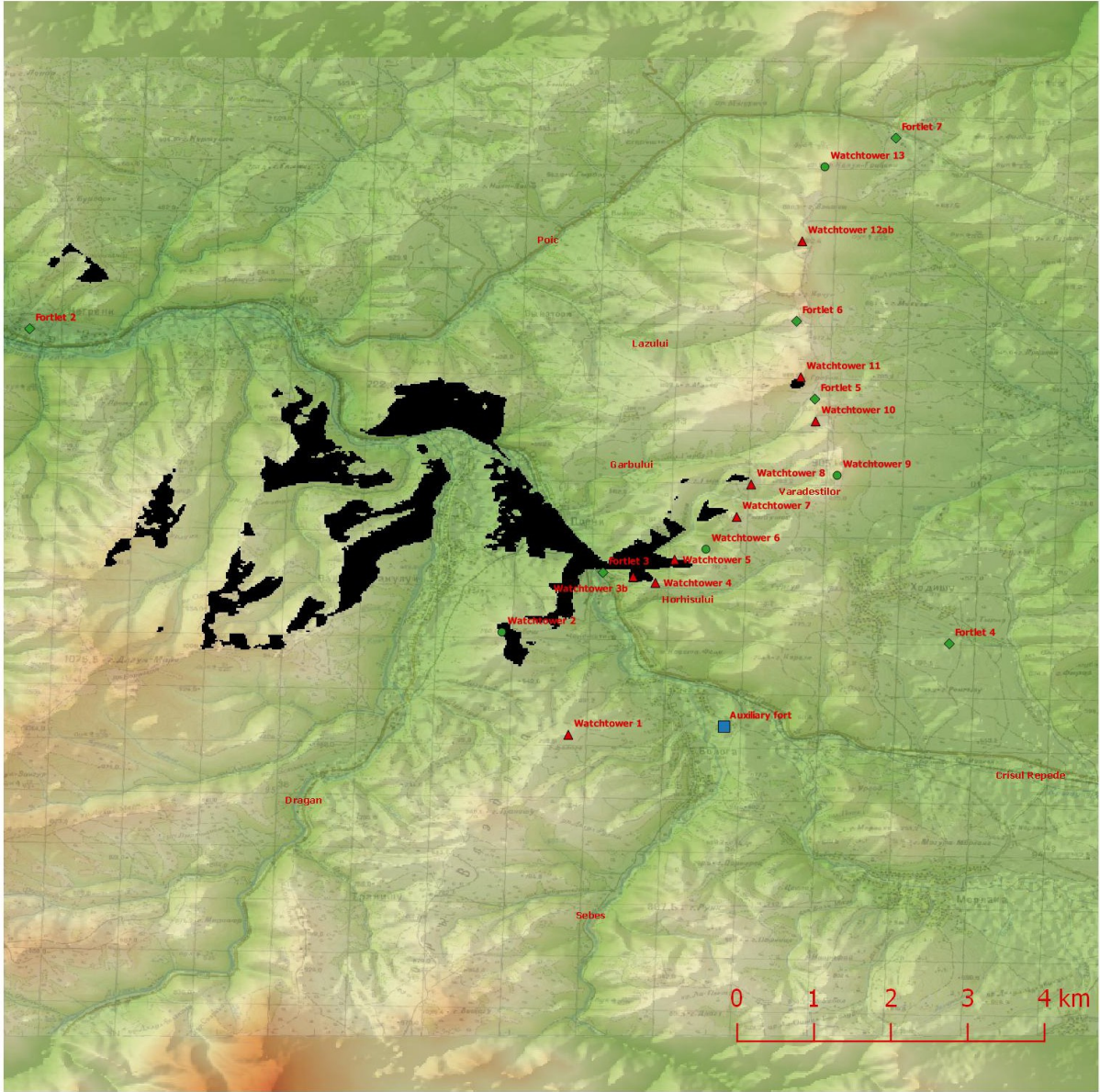

Figure 20. Watchtower 3b binary viewshed (Resources and tools: GRASS; QGIS; Soviet Topographic Maps 1: 50 000; SRTM Global DEM - 30 m).

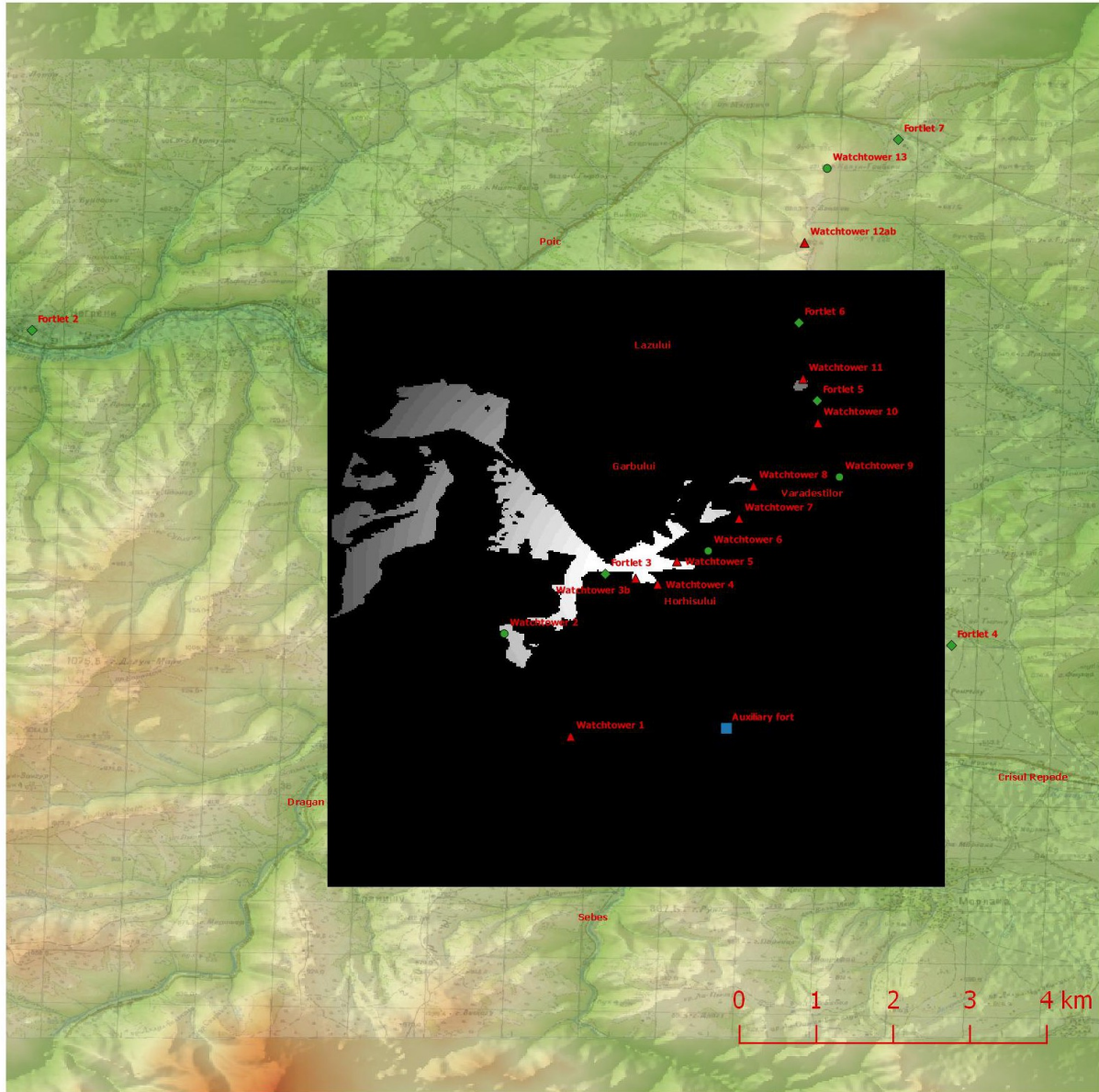

Figure 21. Watchtower 3b fuzzy viewshed with 1' visual arc (Resources and tools: GRASS; QGIS; Soviet Topographic Maps 1: 50 000; SRTM Global DEM - 30 m).



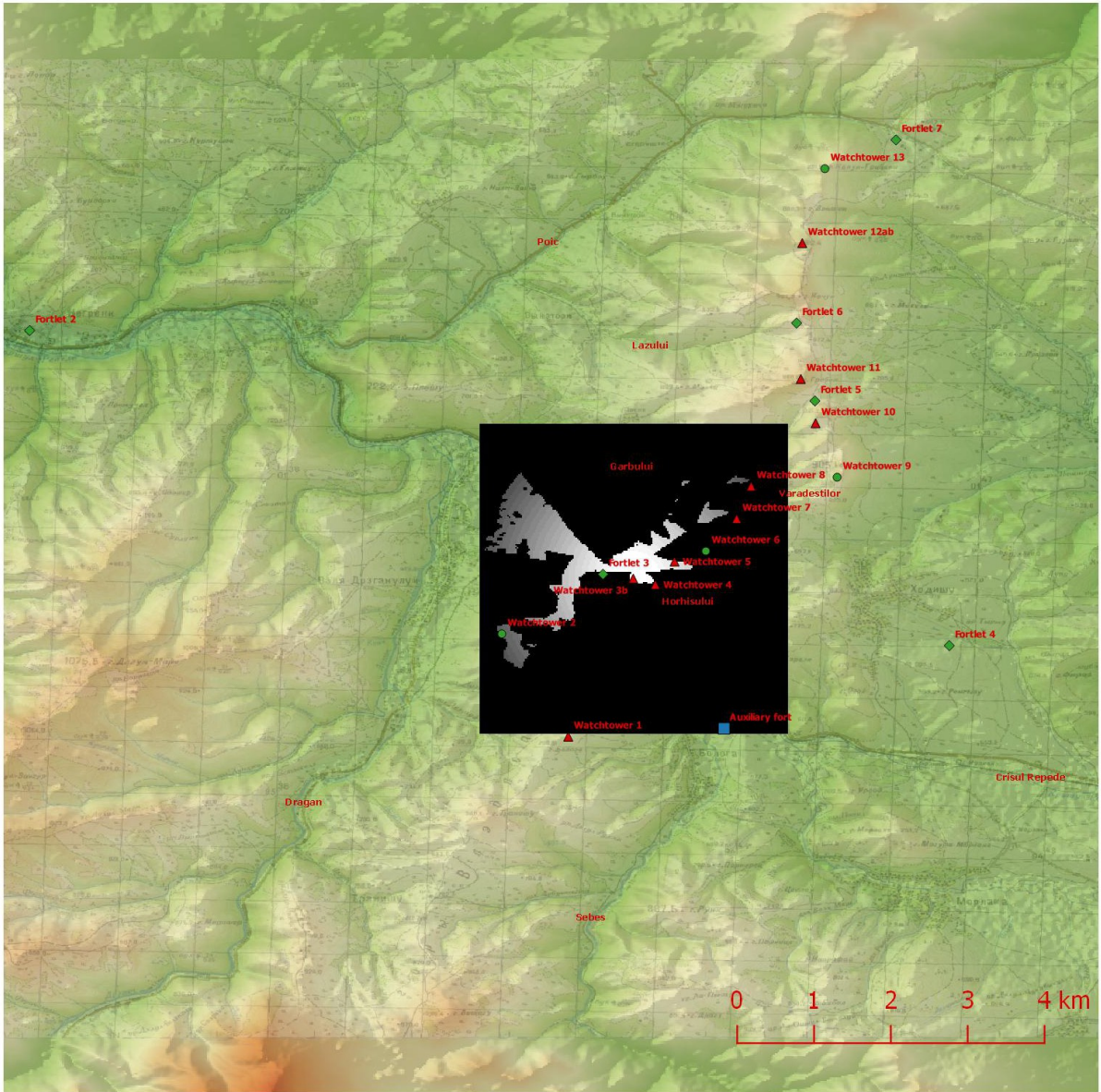

Figure 22. Watchtower 3b fuzzy viewshed with with 2' visual arc (Resources and tools: GRASS; QGIS; Soviet Topographic Maps 1: 50 000; SRTM Global DEM - 30 m).

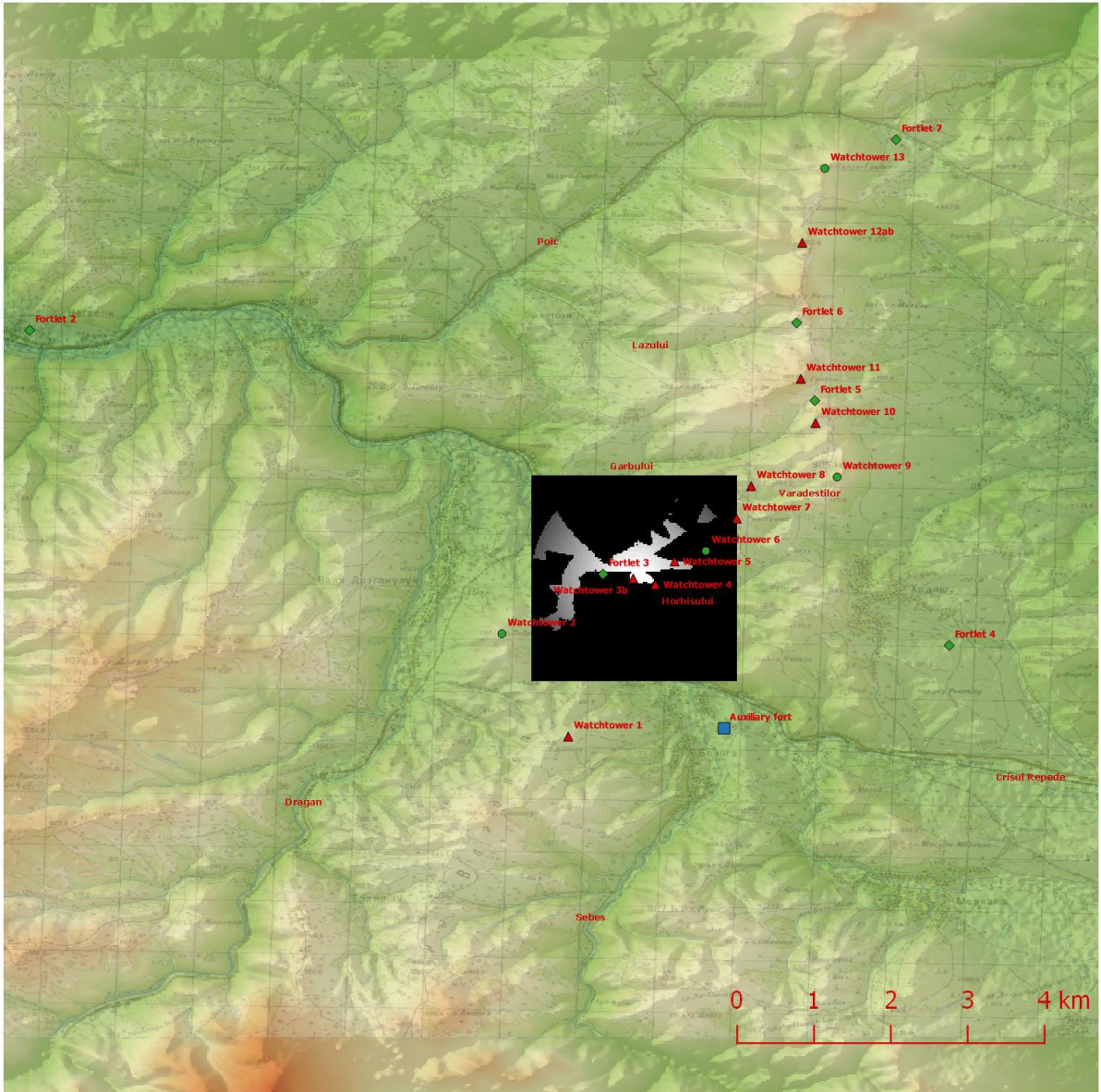

Figure 23. Watchtower 3b fuzzy viewshed with 3' visual arc (Resources and tools: GRASS; QGIS; Soviet Topographic Maps 1: 50 000; SRTM Global DEM - 30 m).



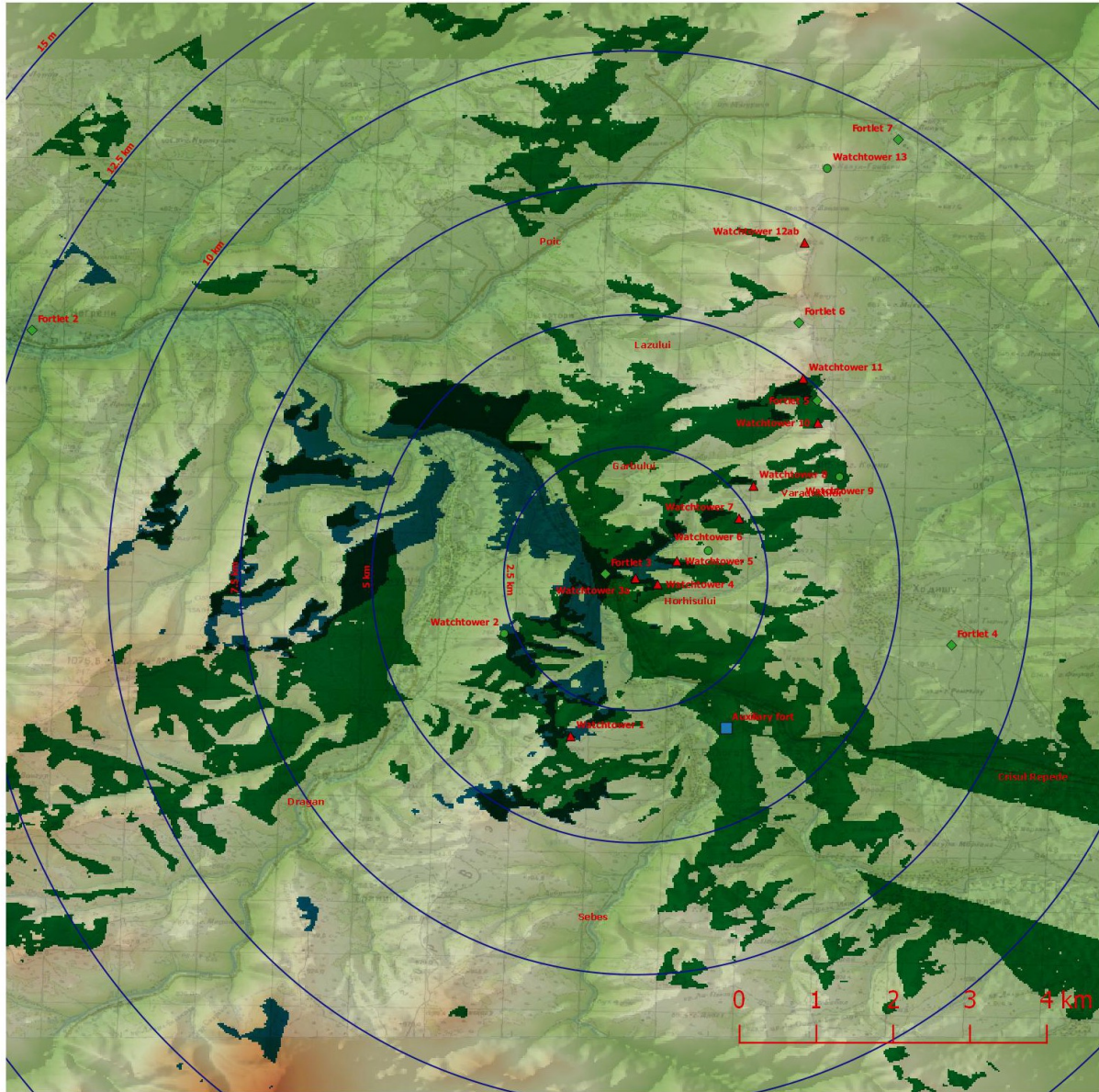

Figure 24. Watchtower 3a's binary viewshed in comparison with Watchtower 1's (Resources and tools: GRASS; QGIS; Soviet Topographic Maps 1: 50 000; SRTM Global DEM - 30 m).



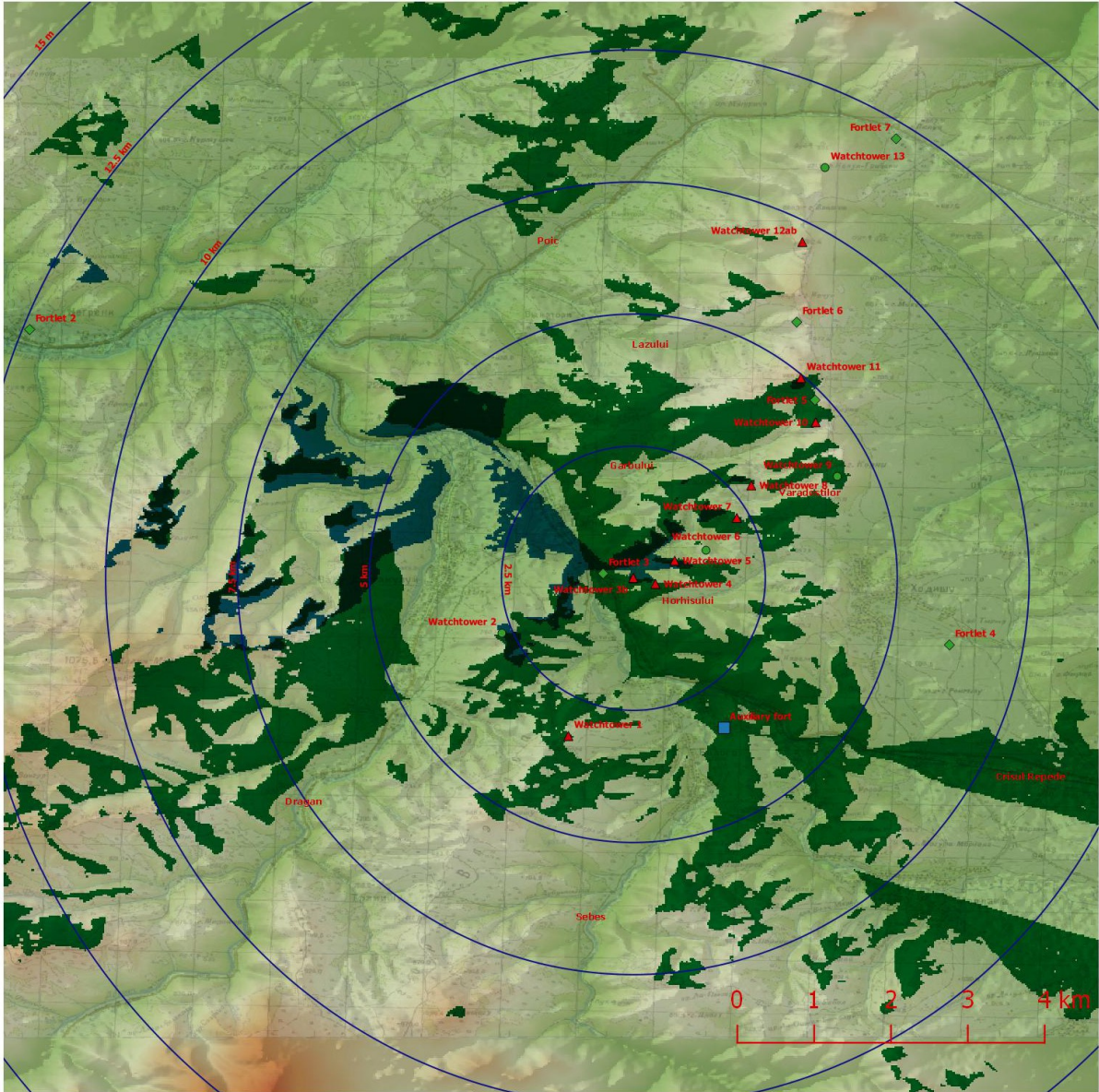

Figure 25. Watchtower 3b's binary viewshed in comparison with Watchtower 1's (Resources and tools: GRASS; QGIS; Soviet Topographic Maps 1: 50 000; SRTM Global DEM - 30 m).



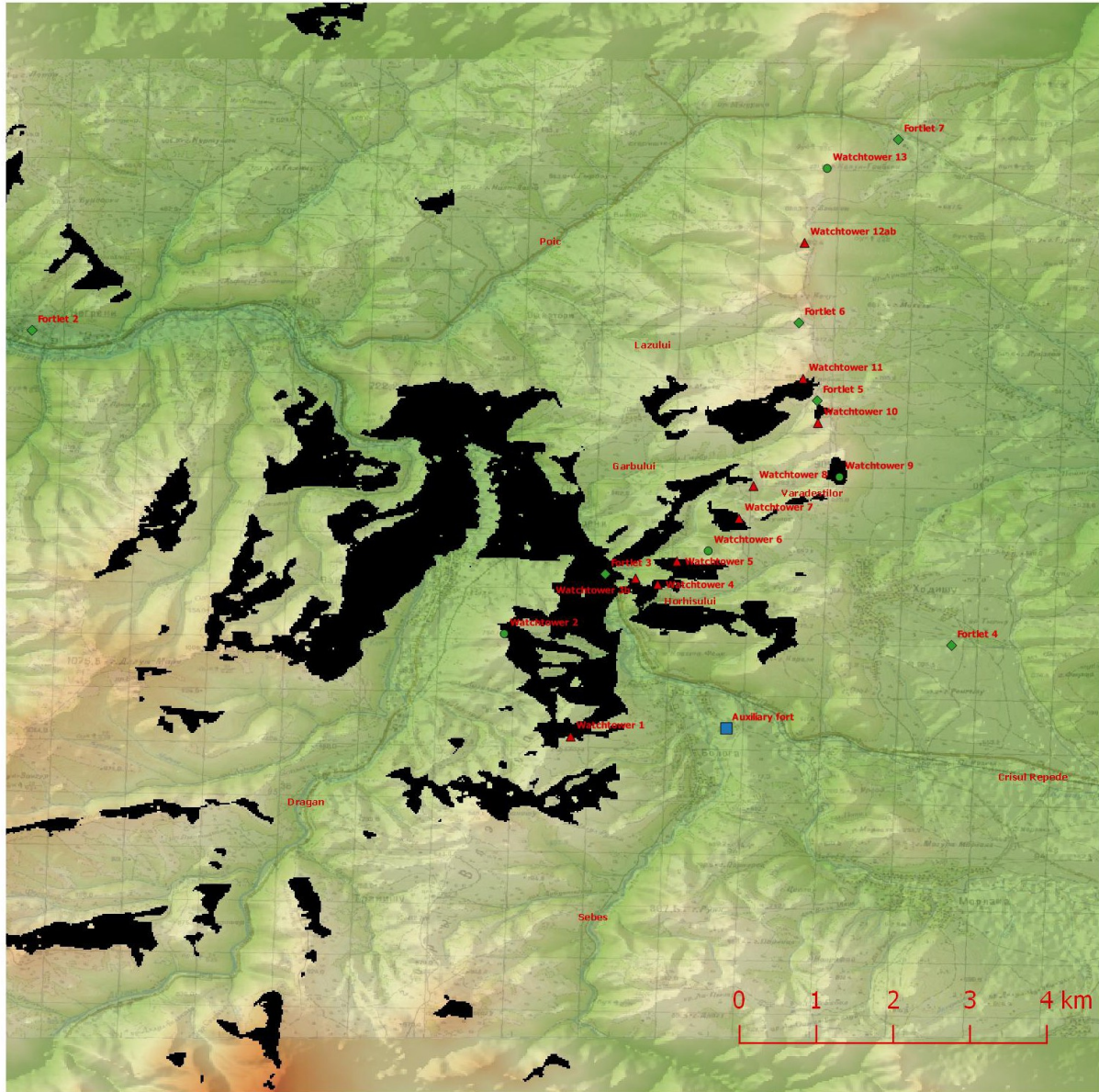

Figure 26. Watchtower 4 binary viewshed (Resources and tools: GRASS; QGIS; Soviet Topographic Maps 1: 50 000; SRTM Global DEM - 30 m).

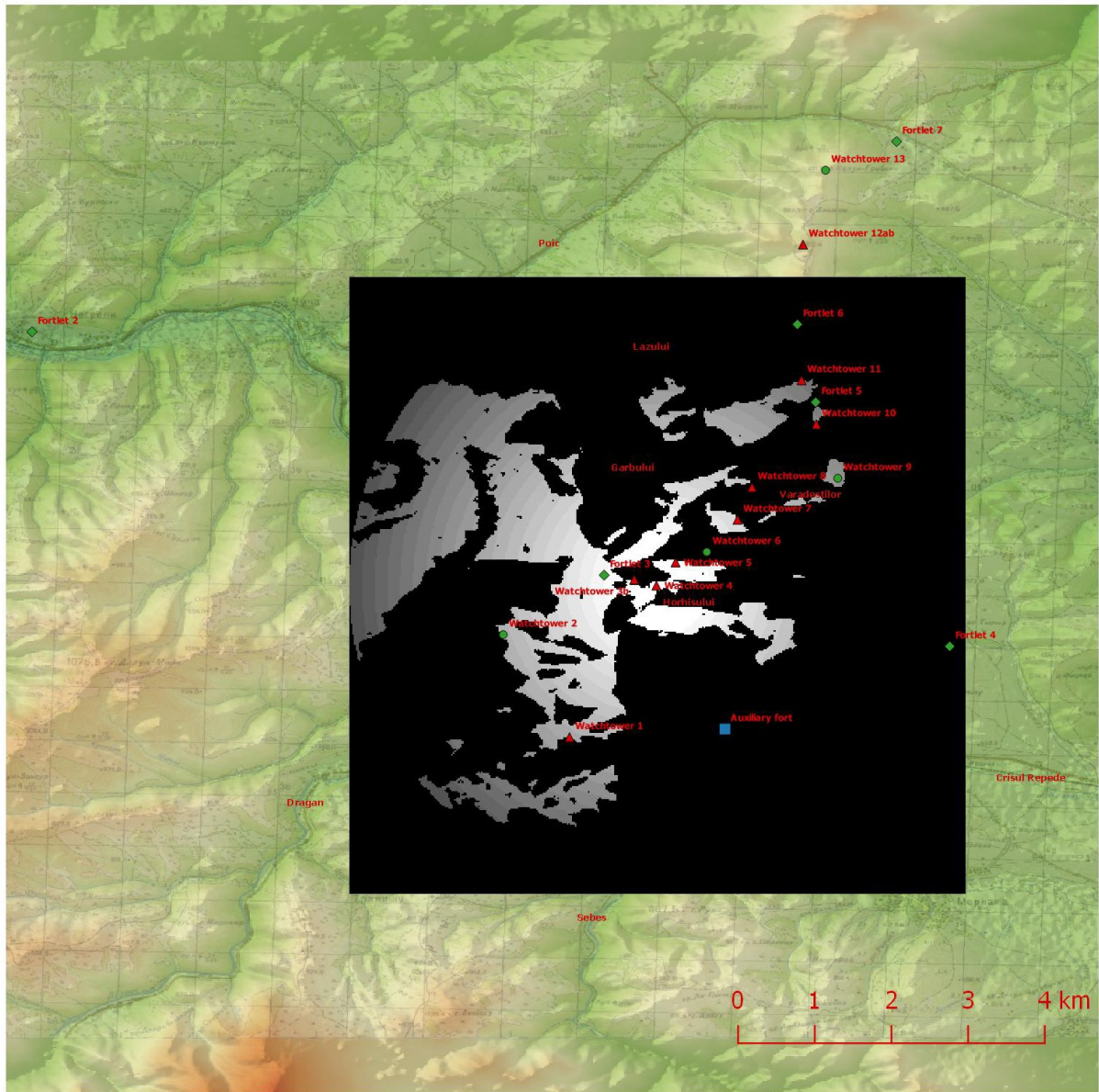

Figure 27. Watchtower 4 fuzzy viewshed with 1' visual arc (Resources and tools: GRASS; QGIS; Soviet Topographic Maps 1: 50 000; SRTM Global DEM - 30 m).



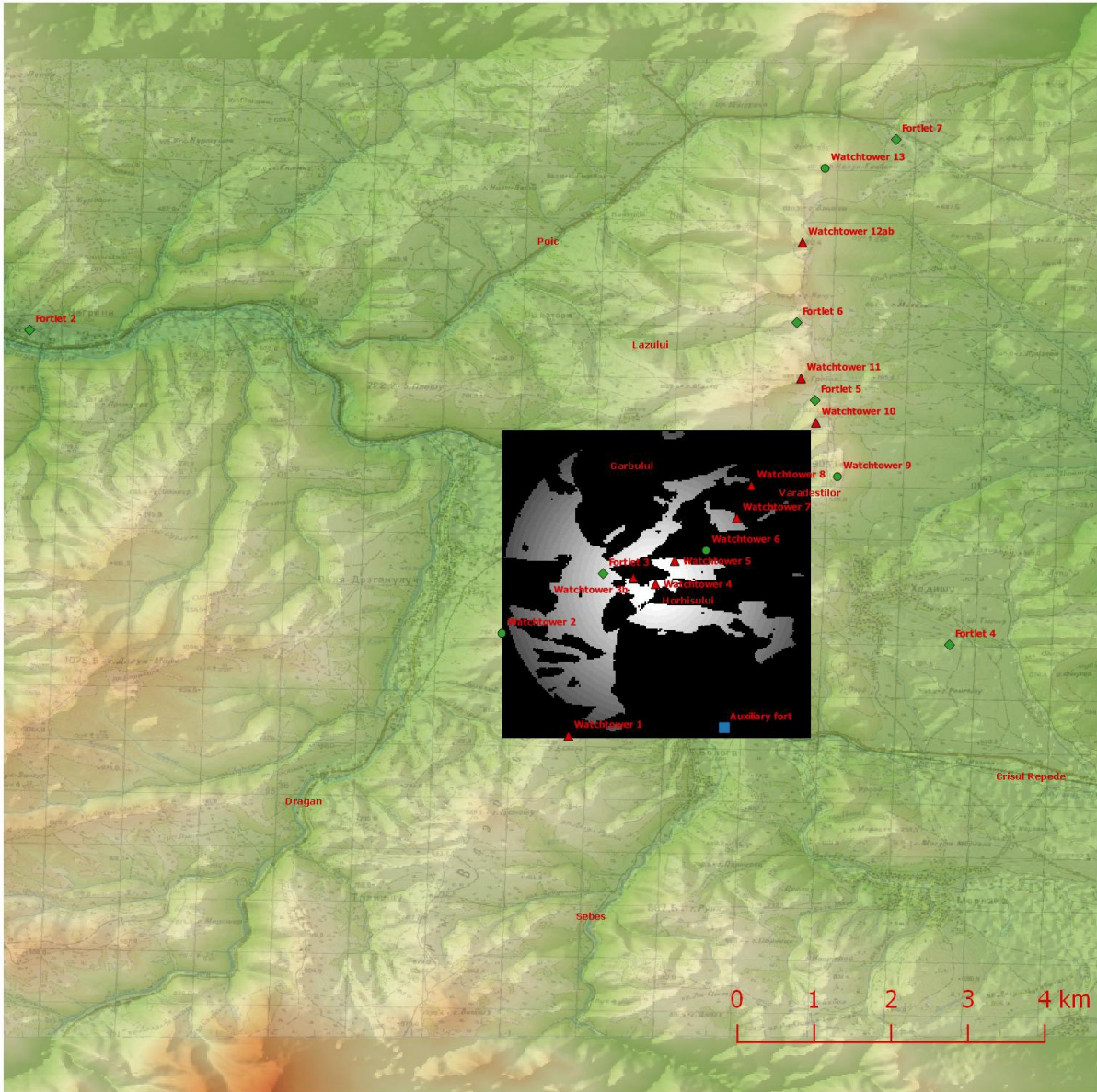

Figure 28. Watchtower 4 fuzzy viewshed with 2' visual arc (Resources and tools: GRASS; QGIS; Soviet Topographic Maps 1: 50 000; SRTM Global DEM - 30 m).



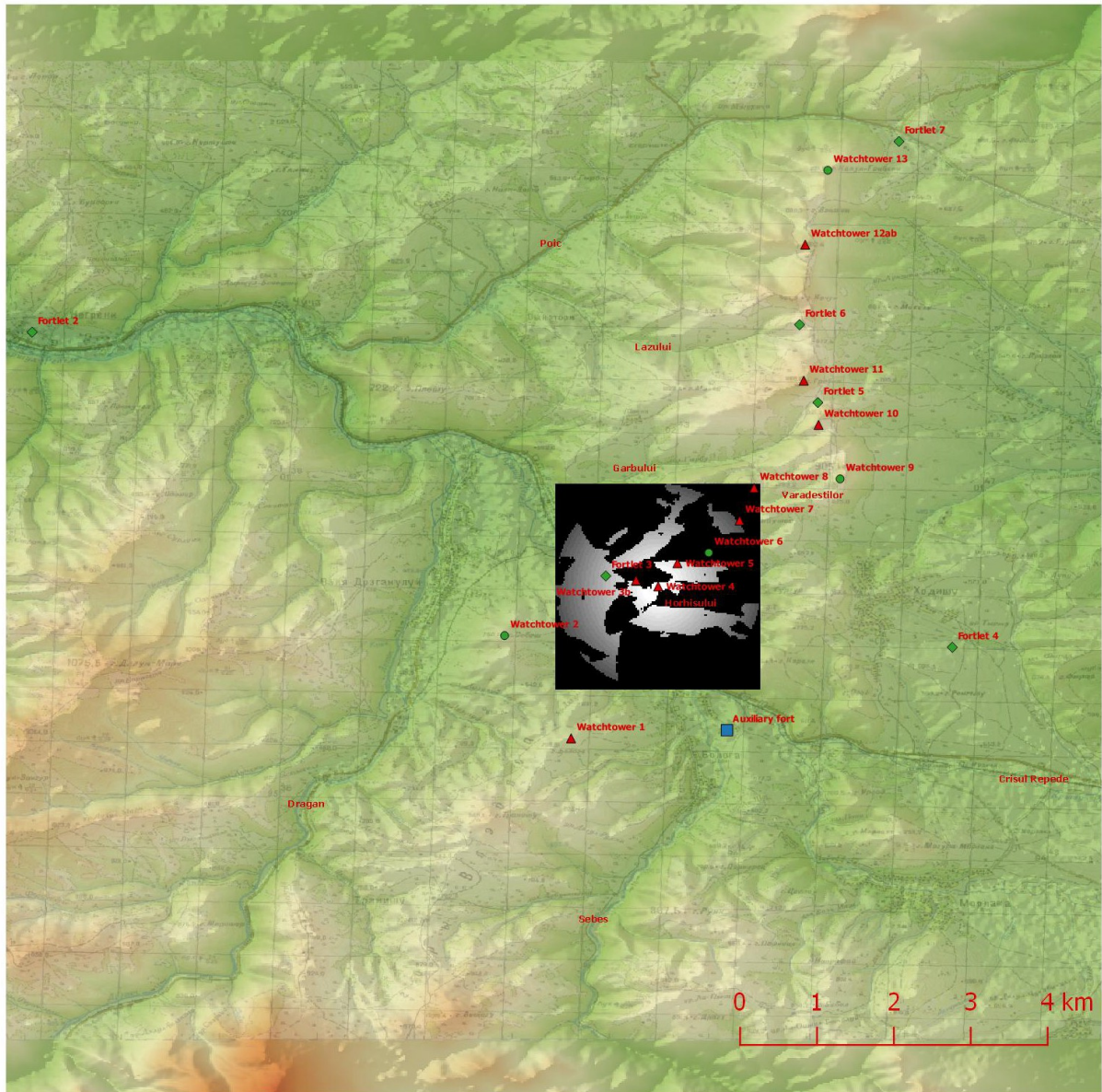

Figure 29. Watchtower 4 fuzzy viewshed with 3' visual arc (Resources and tools: GRASS; QGIS; Soviet Topographic Maps 1: 50 000; SRTM Global DEM - 30 m).



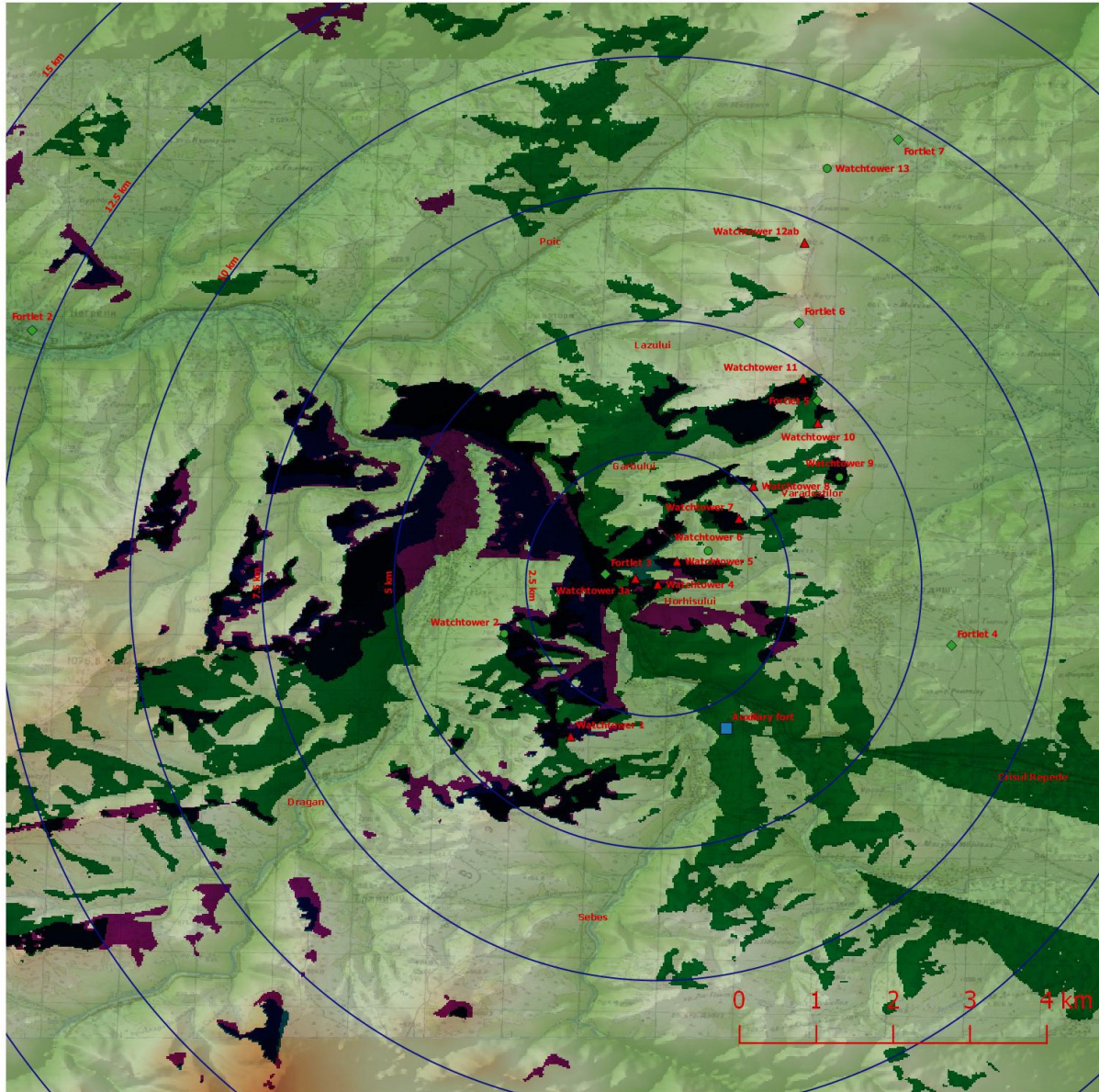

Figure 30. Watchtower 4's binary viewshed in comparison with Watchtower 1's and 3a's (Resources and tools: GRASS; QGIS; Soviet Topographic Maps 1: 50 000; SRTM Global DEM - 30 m).



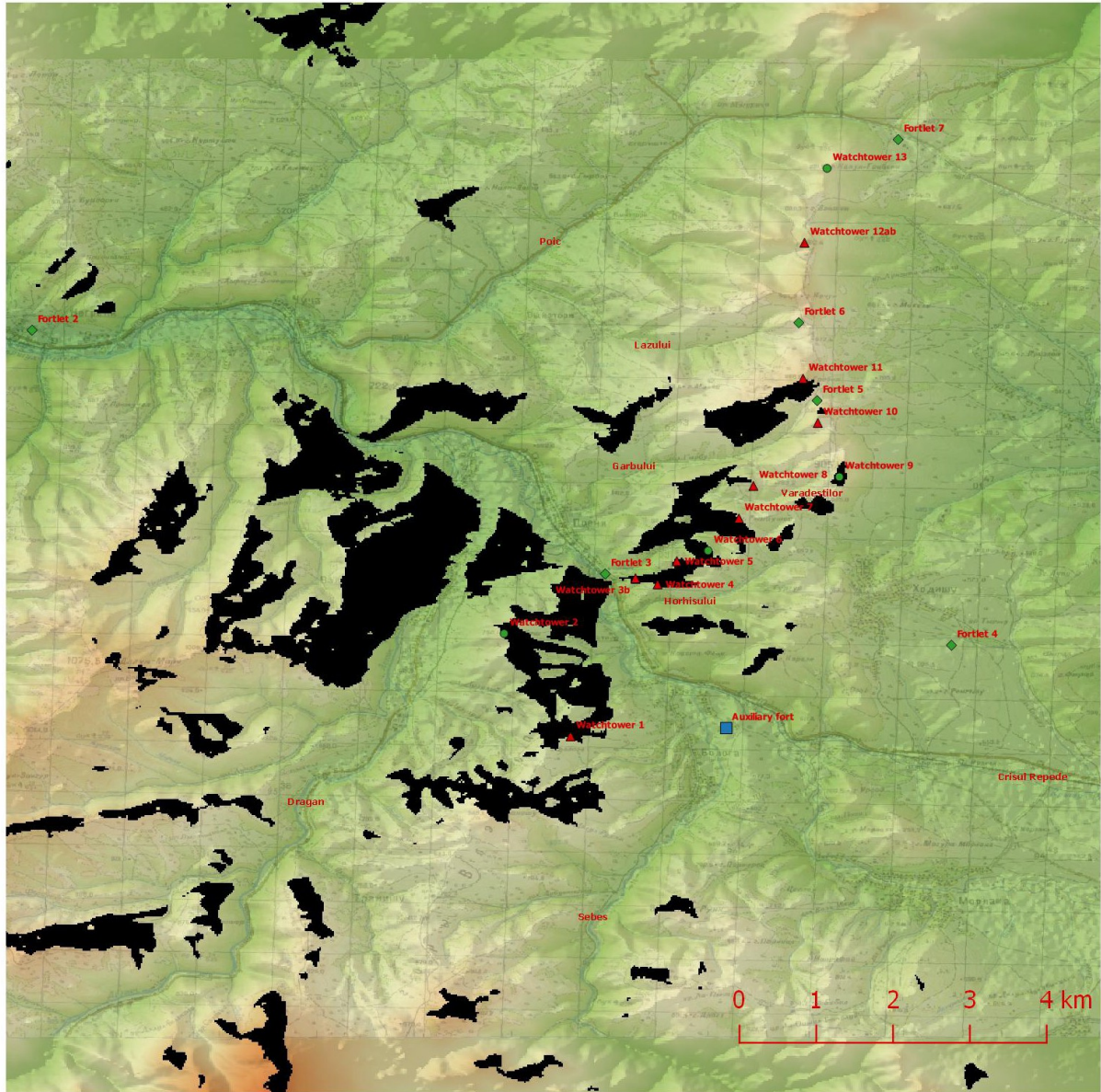

Figure 31. Watchtower 5 binary viewshed (Resources and tools: GRASS; QGIS; Soviet Topographic Maps 1: 50 000; SRTM Global DEM - 30 m).

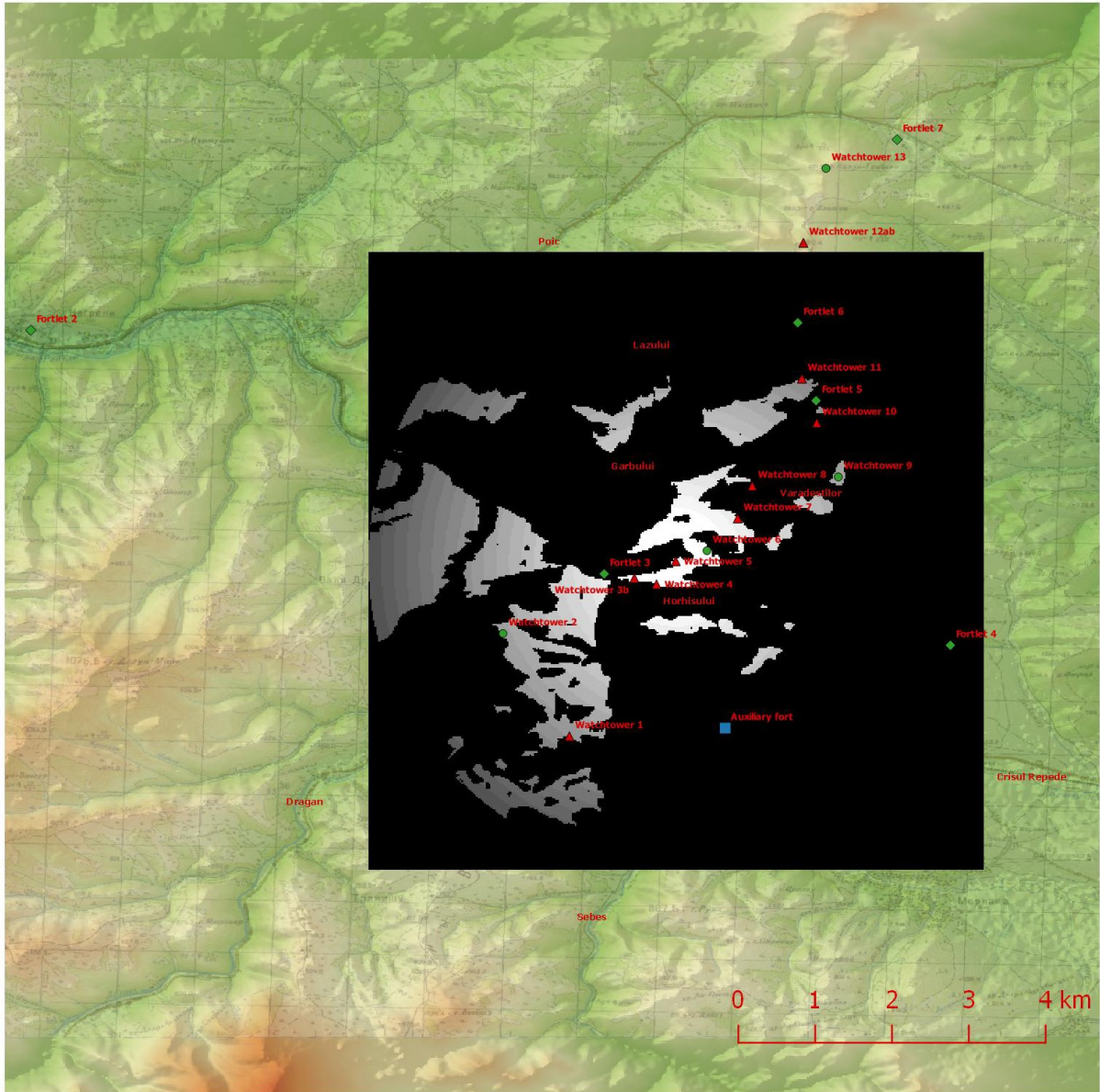

Figure 32. Watchtower 5 fuzzy viewshed with 1' visual arc (Resources and tools: GRASS; QGIS; Soviet Topographic Maps 1: 50 000; SRTM Global DEM - 30 m).



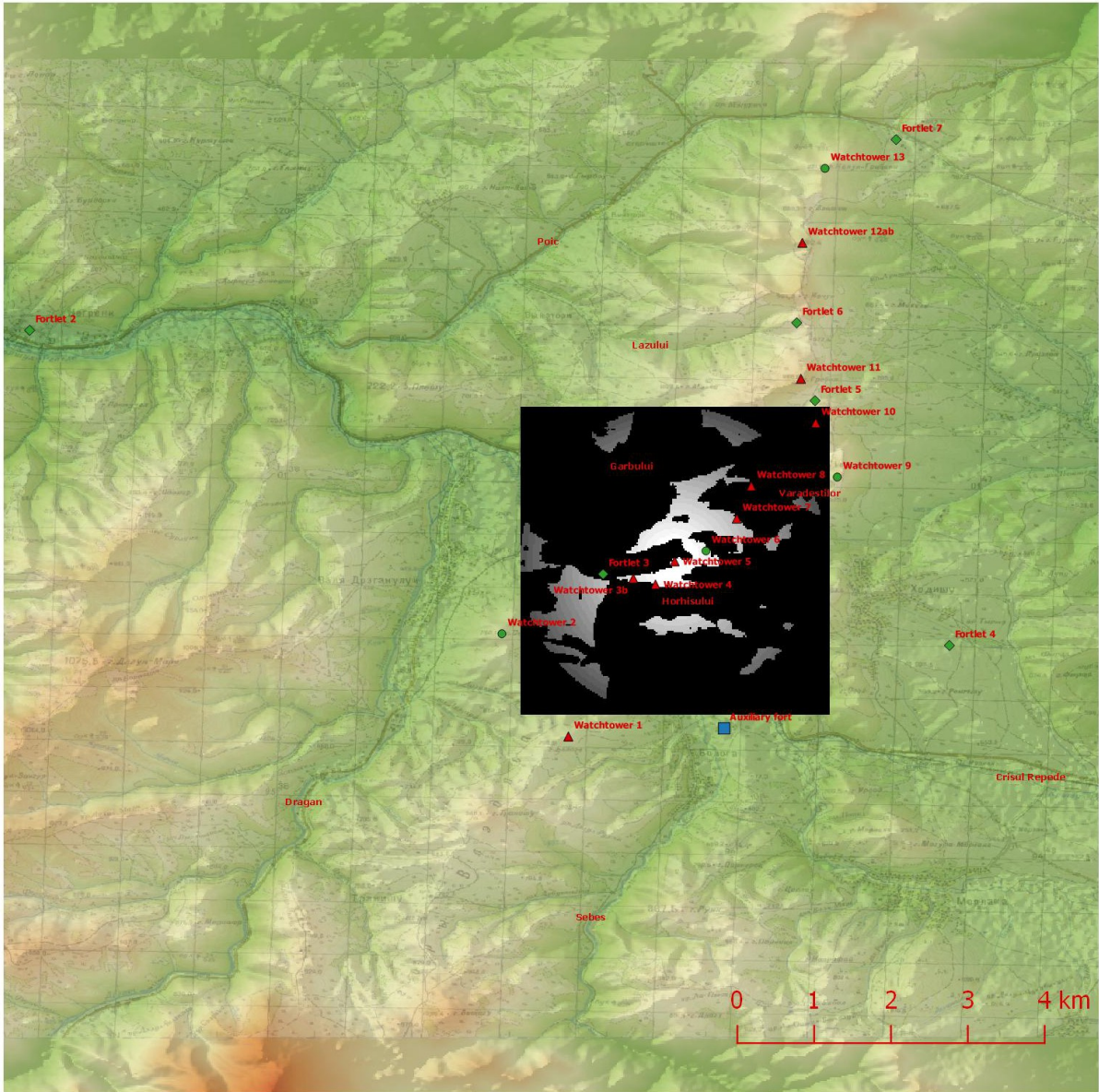

Figure 33. Watchtower 5 fuzzy viewshed with 2' visual arc (Resources and tools: GRASS; QGIS; Soviet Topographic Maps 1: 50 000; SRTM Global DEM - 30 m).



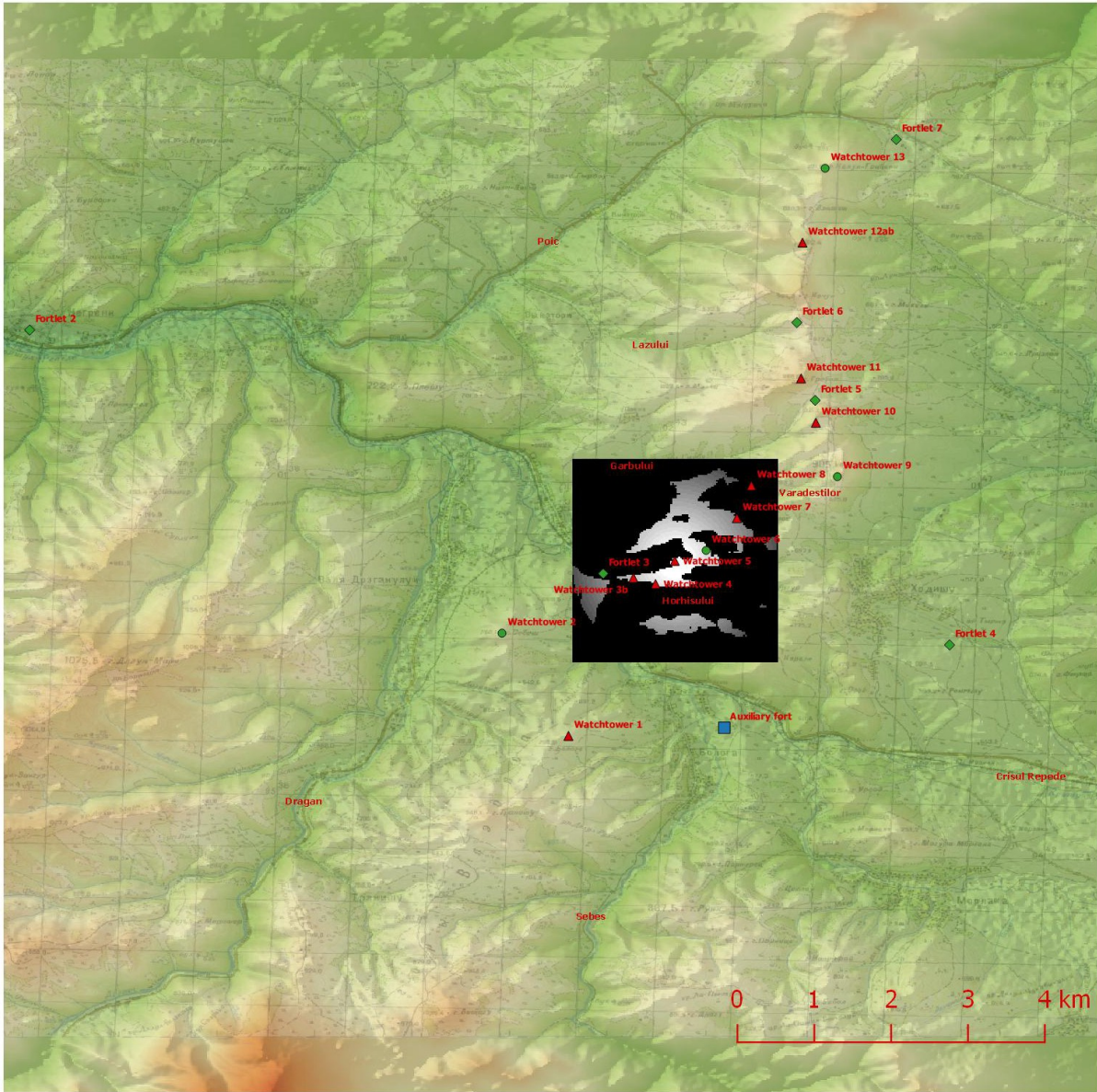

Figure 34. Watchtower 5 fuzzy viewshed with 3' visual arc (Resources and tools: GRASS; QGIS; Soviet Topographic Maps 1: 50 000; SRTM Global DEM - 30 m).



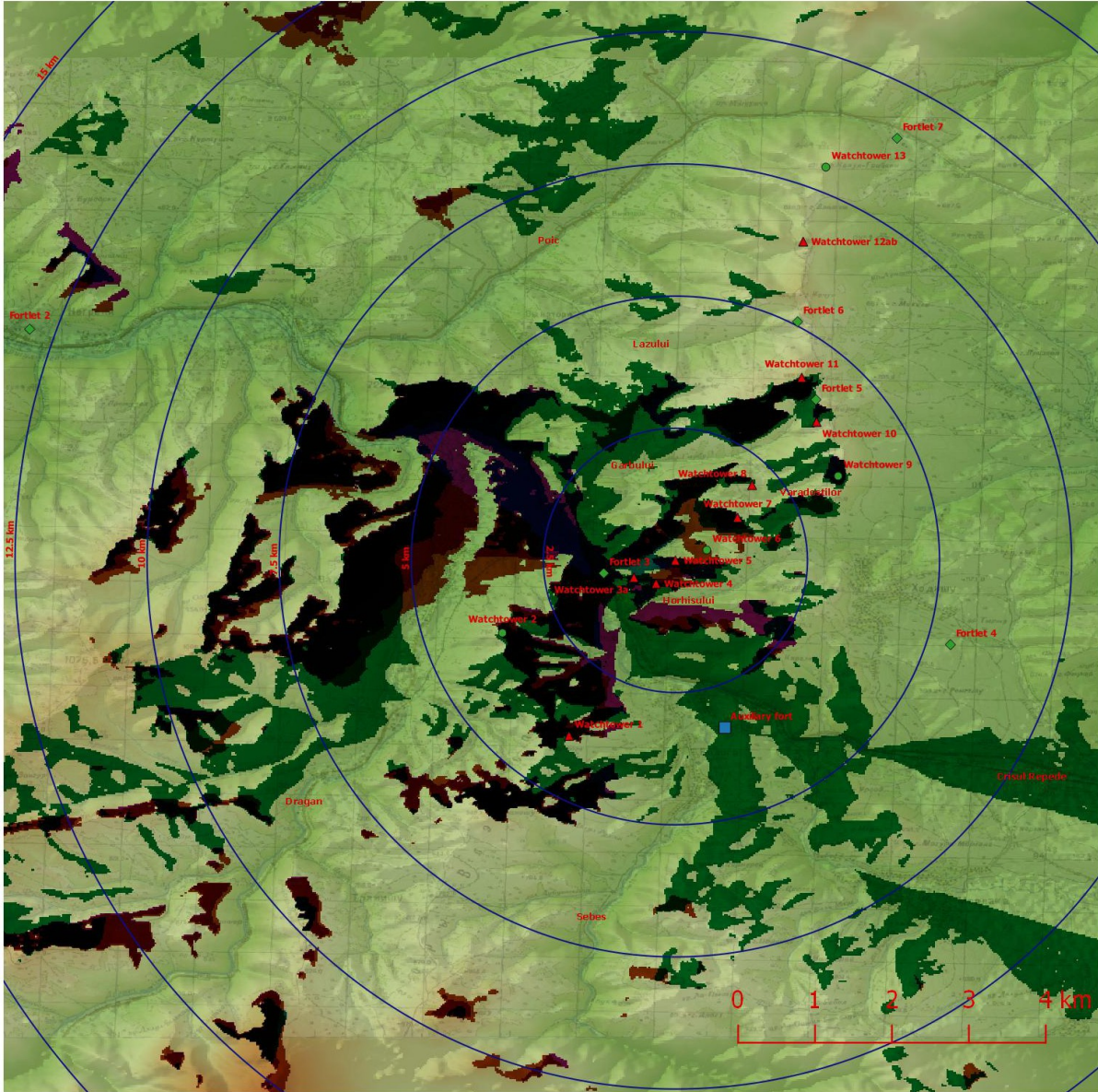

Figure 35. Watchtower 5's binary viewshed in comparison with Watchtower 1's, 3a's and 4's (Resources and tools: GRASS; QGIS; Soviet Topographic Maps 1: 50 000; SRTM Global DEM - 30 m).



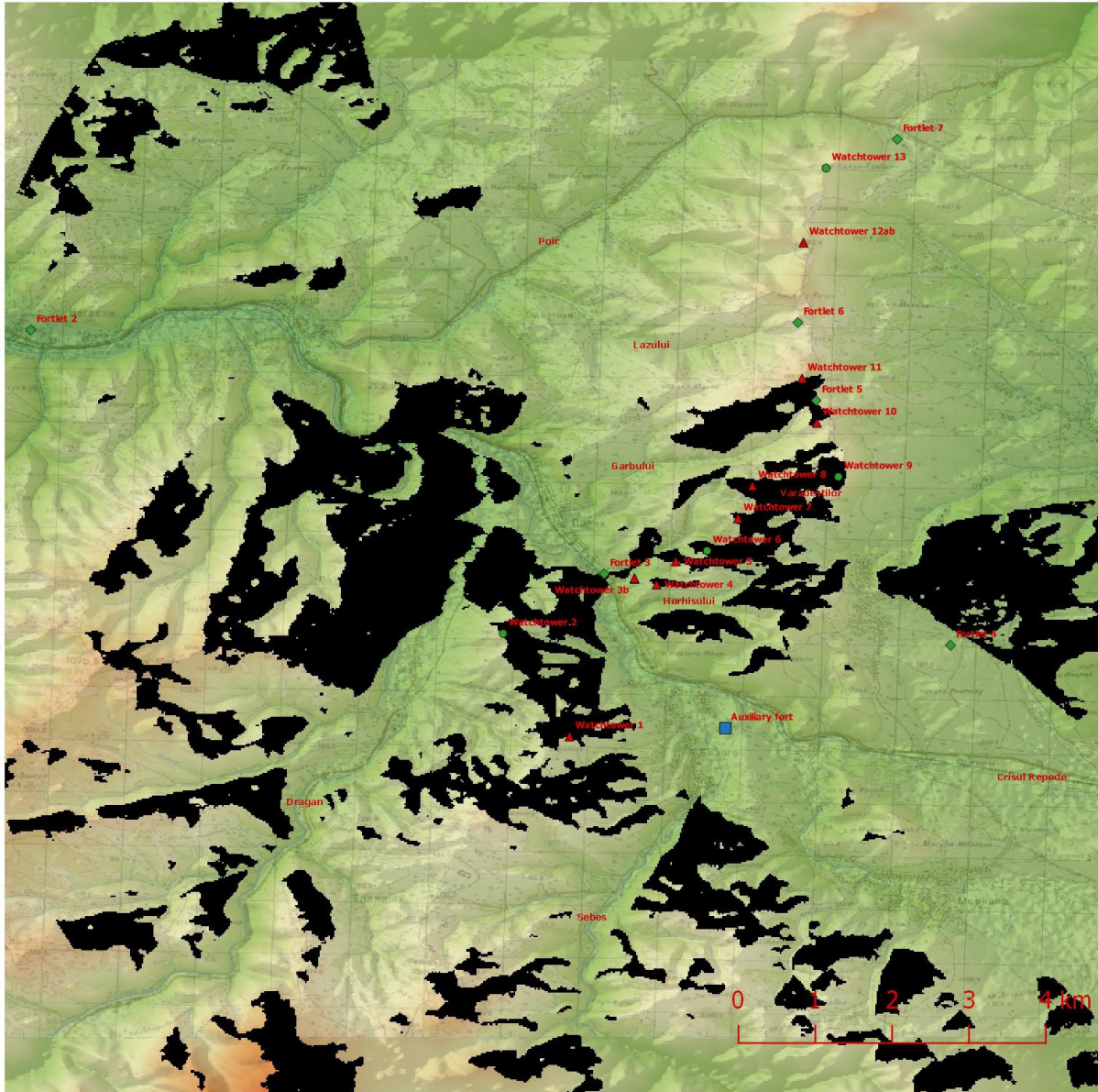

Figure 36. Watchtower 7 binary viewshed (Resources and tools: GRASS; QGIS; Soviet Topographic Maps 1: 50 000; SRTM Global DEM - 30 m).

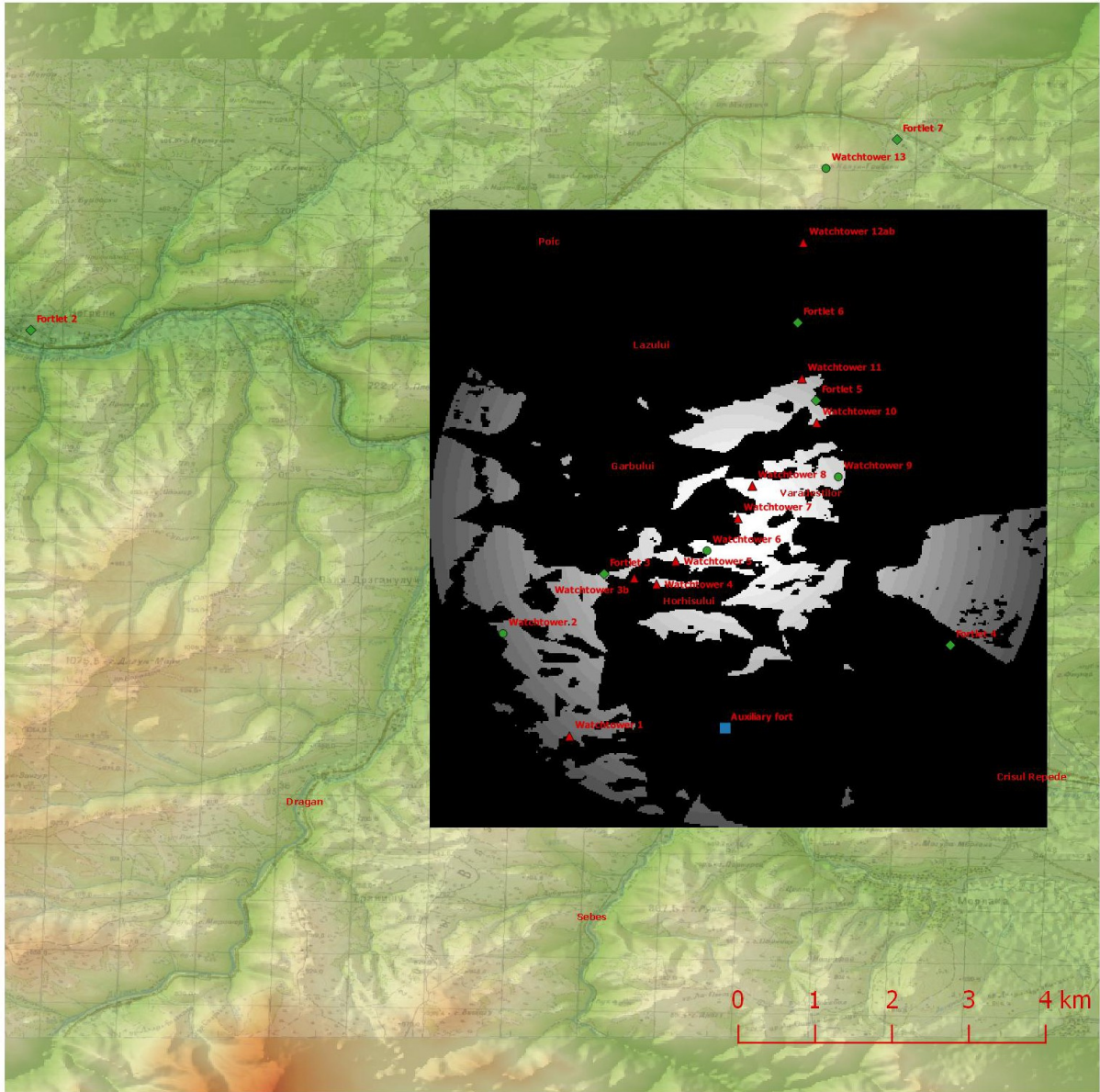

Figure 37. Watchtower 7 fuzzy viewshed with 1' visual arc (Resources and tools: GRASS; QGIS; Soviet Topographic Maps 1: 50 000; SRTM Global DEM - 30 m).



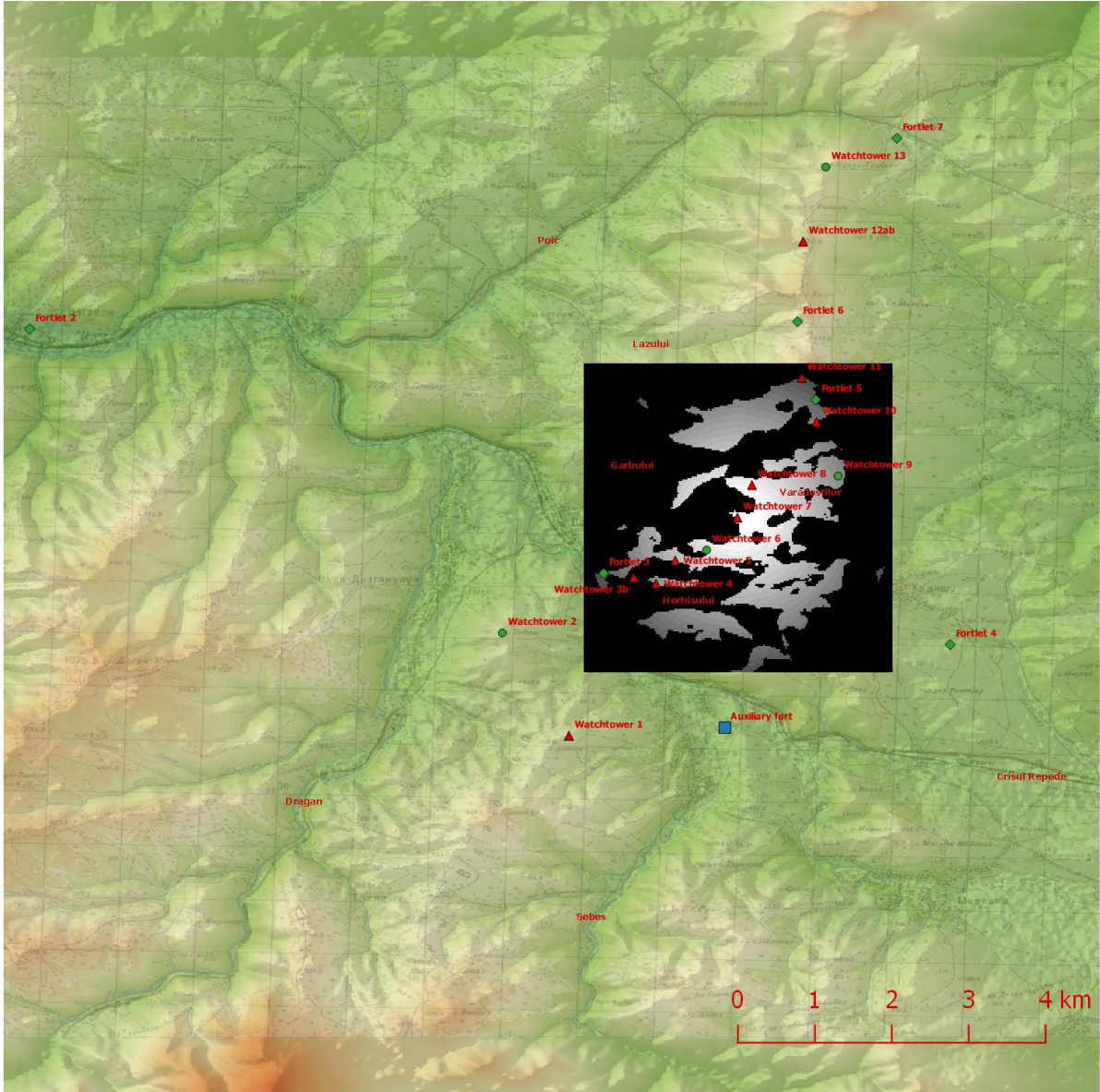

Figure 38. Watchtower 7 fuzzy viewshed with 2' visual arc (Resources and tools: GRASS; QGIS; Soviet Topographic Maps 1: 50 000; SRTM Global DEM - 30 m).



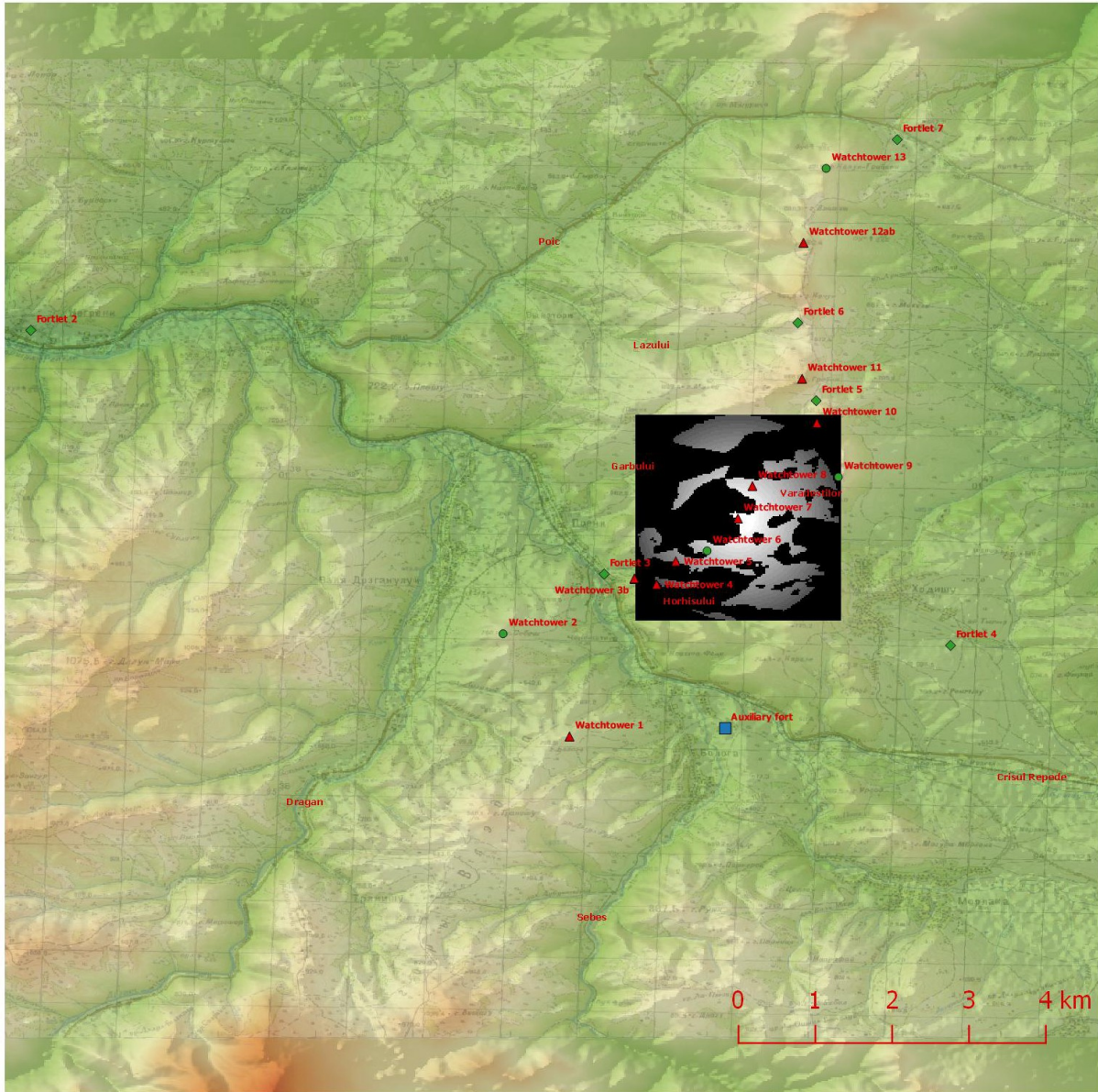

Figure 39. Watchtower 7 fuzzy viewshed with 3' visual arc (Resources and tools: GRASS; QGIS; Soviet Topographic Maps 1: 50 000; SRTM Global DEM - 30 m).



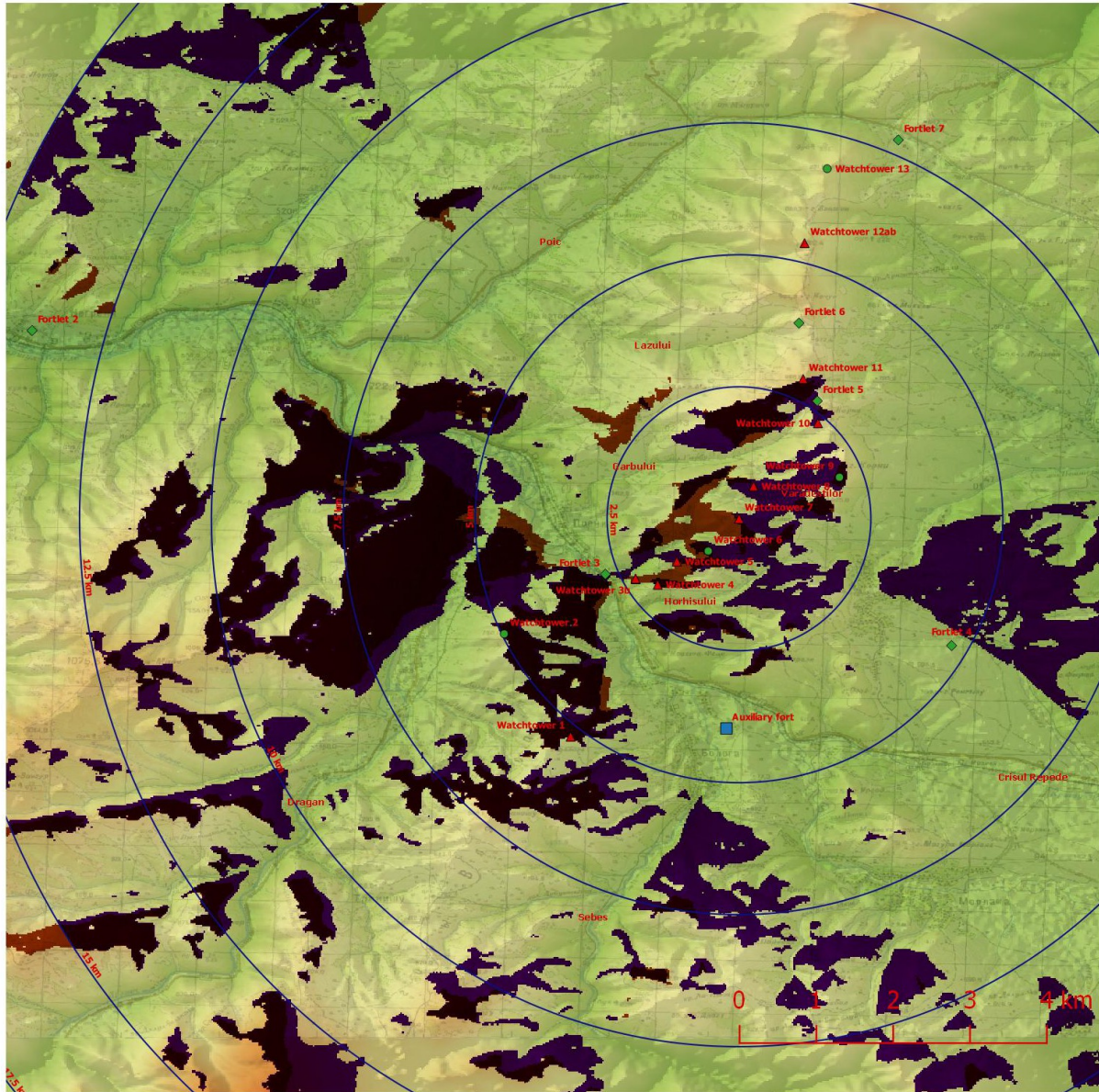

Figure 40. Watchtower 7's binary viewshed in comparison with Watchtower 5's (Resources and tools: GRASS; QGIS; Soviet Topographic Maps 1: 50 000; SRTM Global DEM - 30 m).



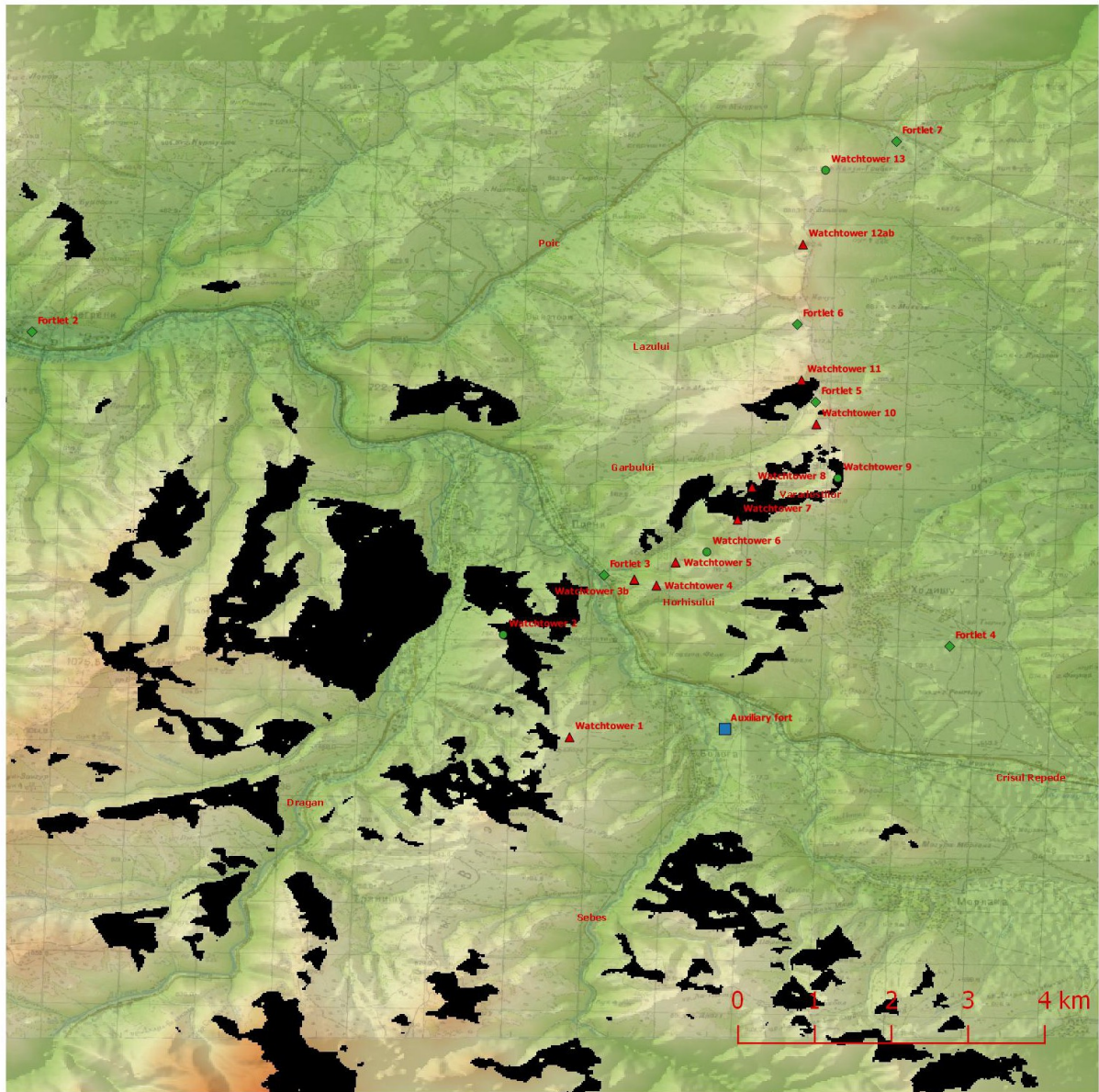

Figure 41. Watchtower 8 binary viewshed (Resources and tools: GRASS; QGIS; Soviet Topographic Maps 1: 50 000; SRTM Global DEM - 30 m).

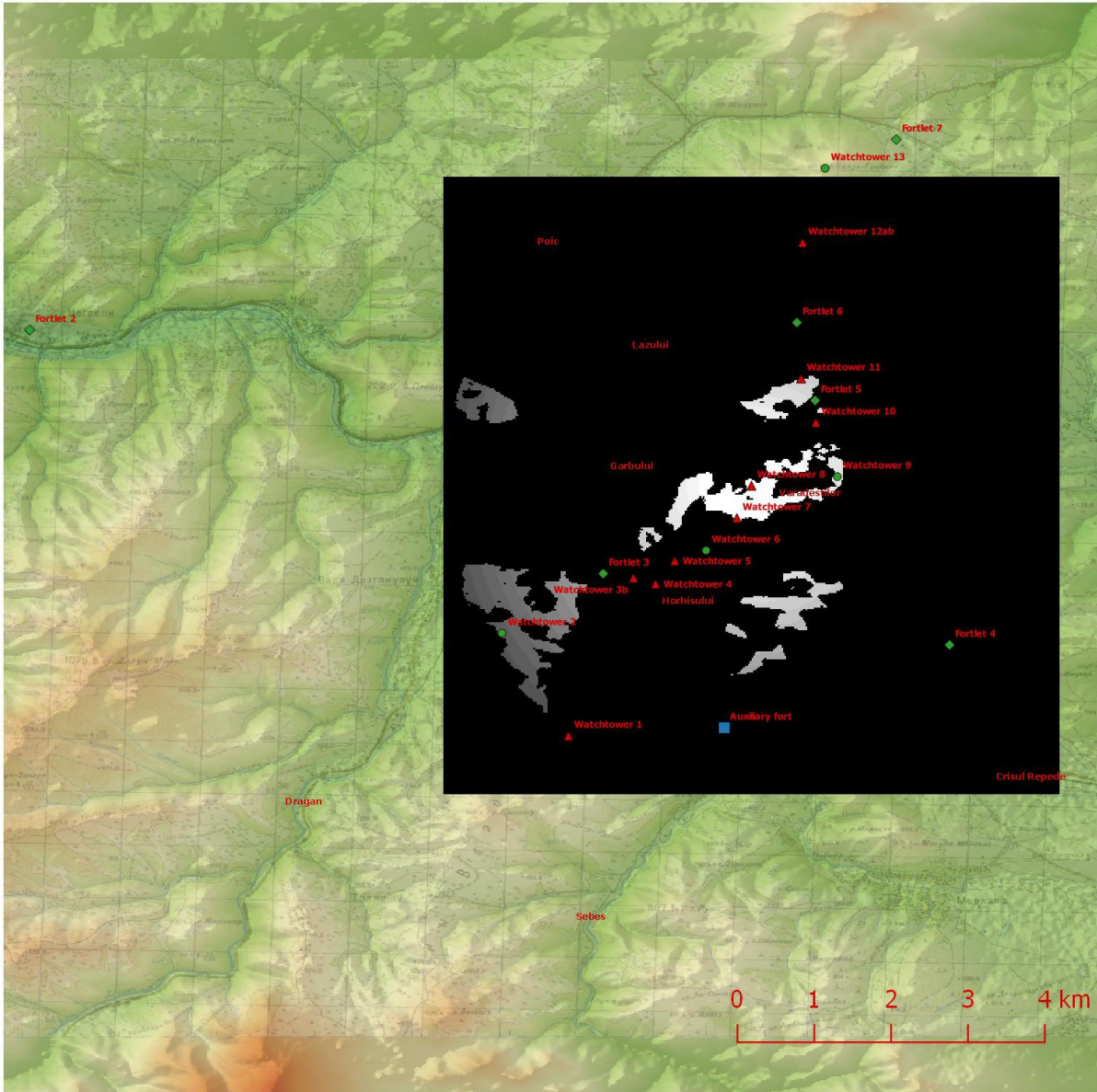

Figure 42. Watchtower 8 fuzzy viewshed with 1' visual arc (Resources and tools: GRASS; QGIS; Soviet Topographic Maps 1: 50 000; SRTM Global DEM - 30 m).



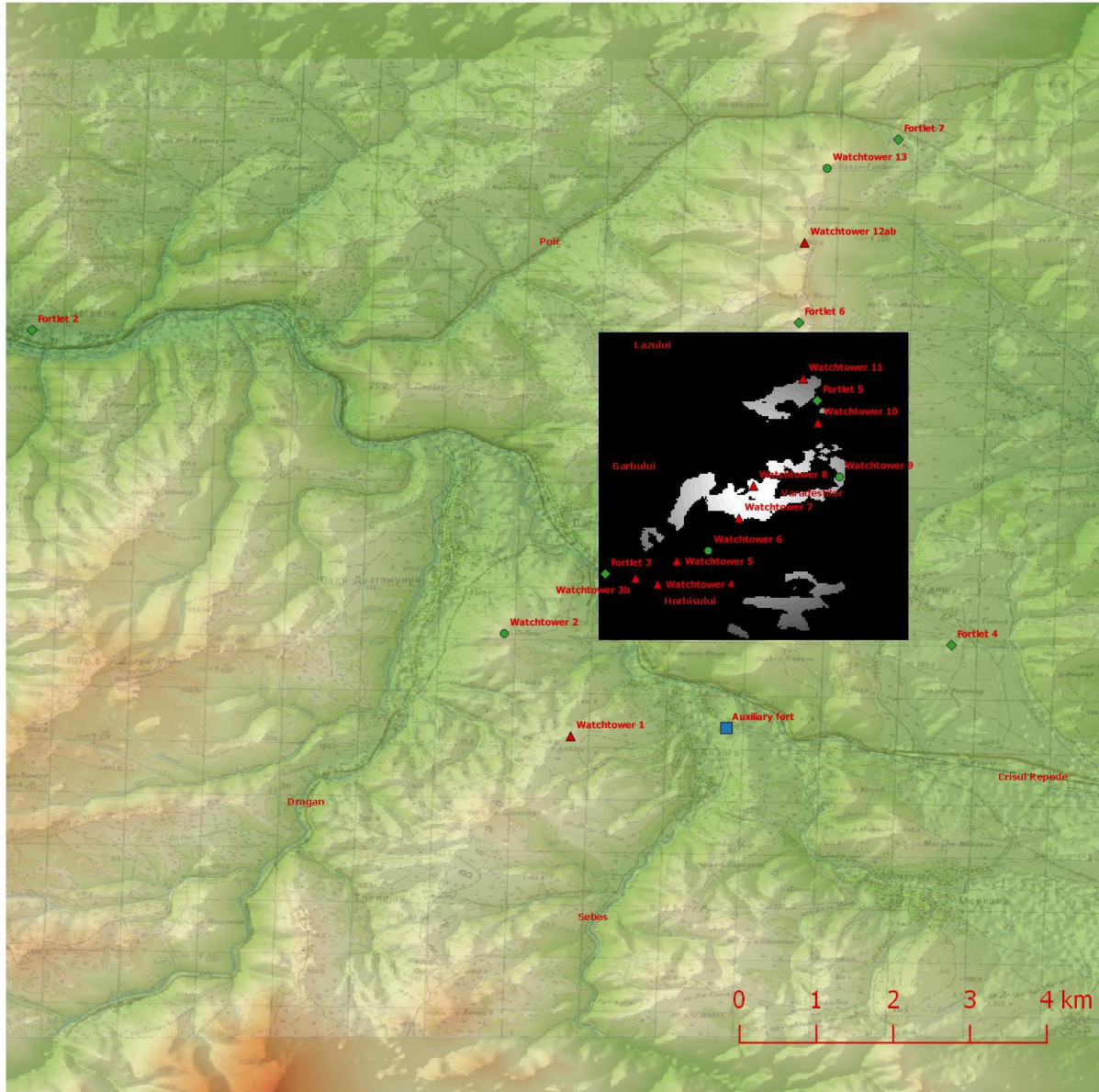

Figure 43. Watchtower 8 fuzzy viewshed with 2' visual arc (Resources and tools: GRASS; QGIS; Soviet Topographic Maps 1: 50 000; SRTM Global DEM - 30 m).



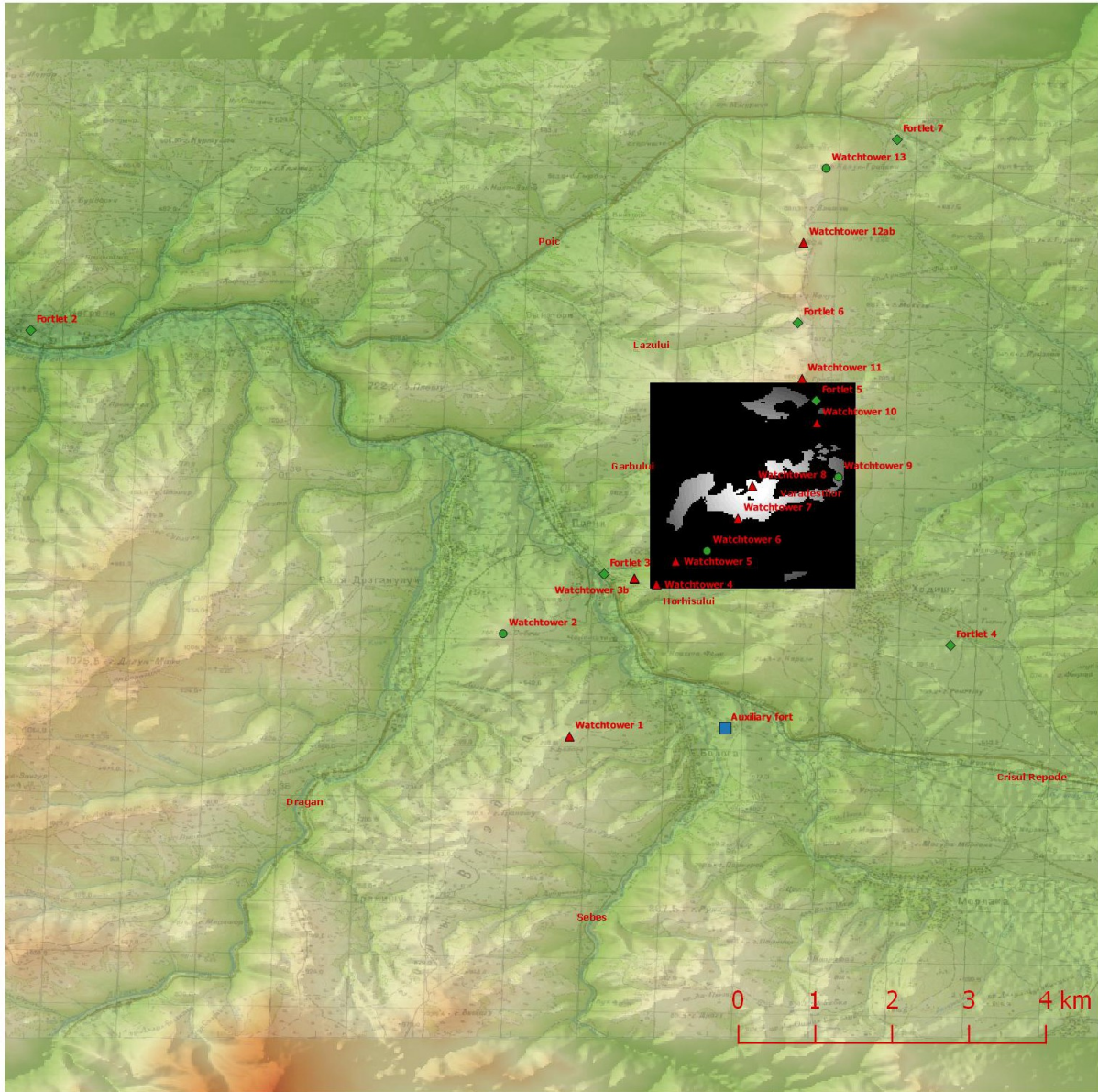

Figure 44. Watchtower 8 fuzzy viewshed with 3' visual arc (Resources and tools: GRASS; QGIS; Soviet Topographic Maps 1: 50 000; SRTM Global DEM - 30 m).



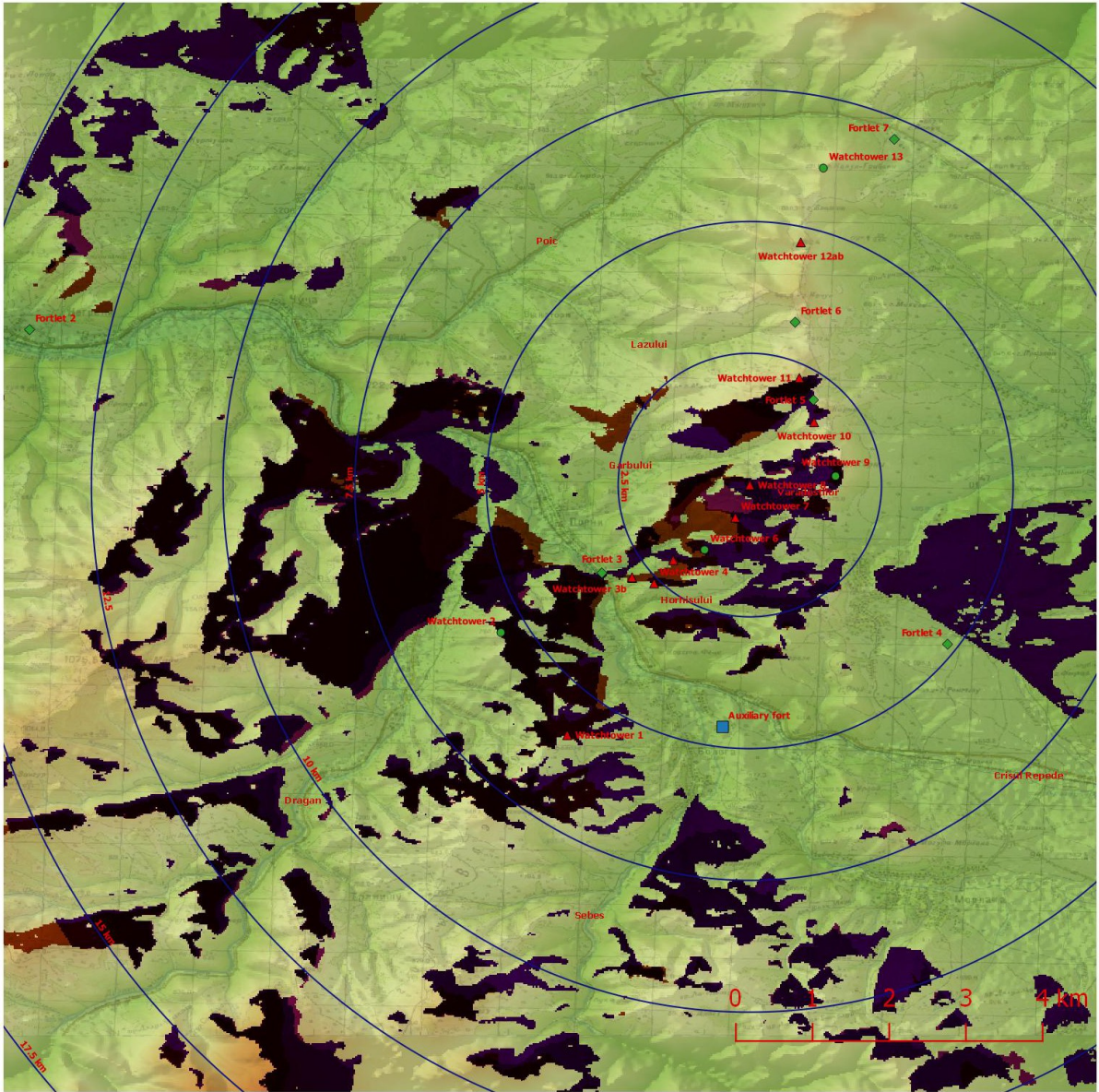

Figure 45. Watchtower 8's binary viewed in comparison with Watchtower 5's and 7's (Resources and tools: GRASS; QGIS; Soviet Topographic Maps 1: 50 000; SRTM Global DEM - 30 m).



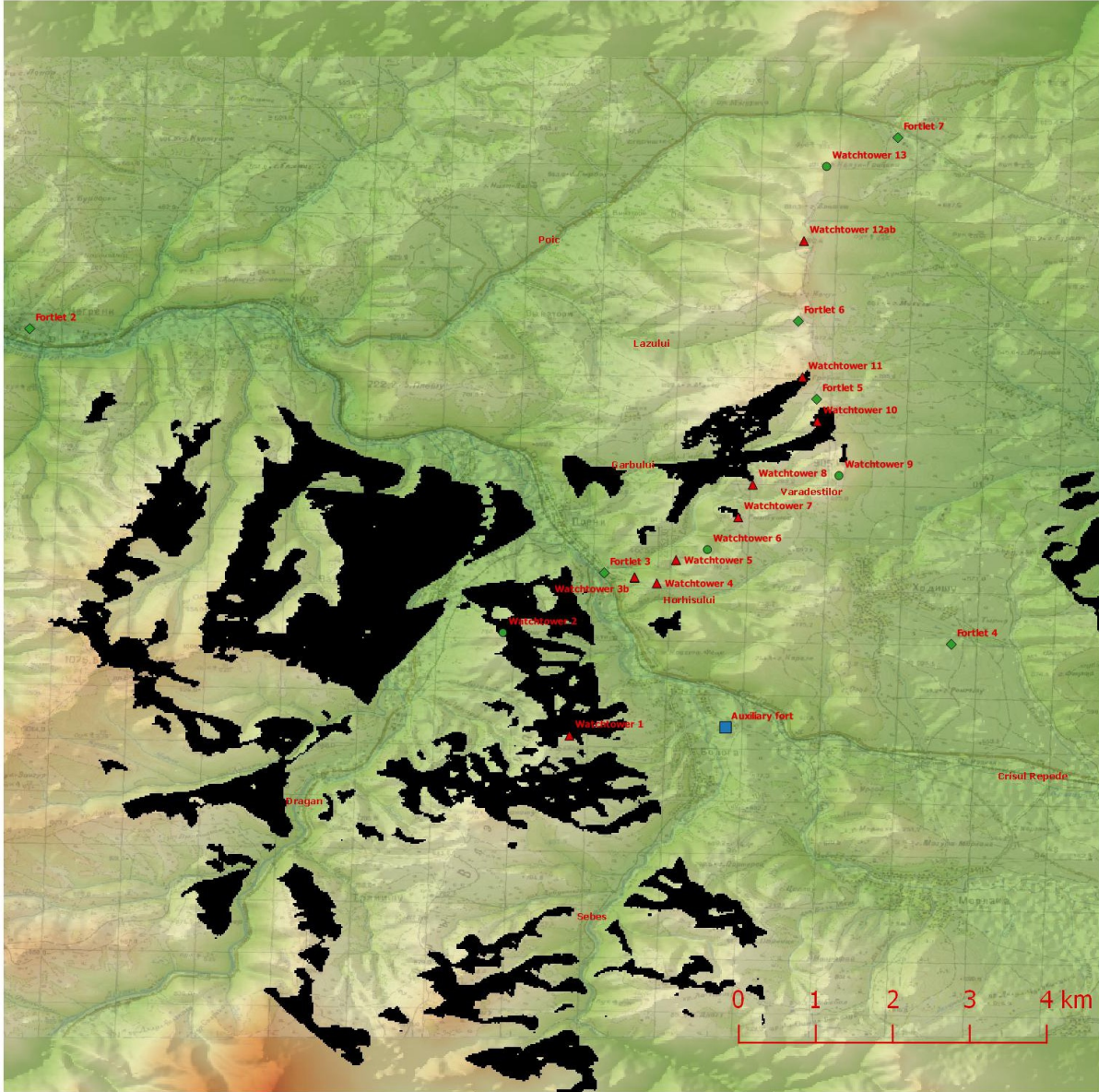

Figure 46. Watchtower 10 binary viewshed (Resources and tools: GRASS; QGIS; Soviet Topographic Maps 1: 50 000; SRTM Global DEM - 30 m).

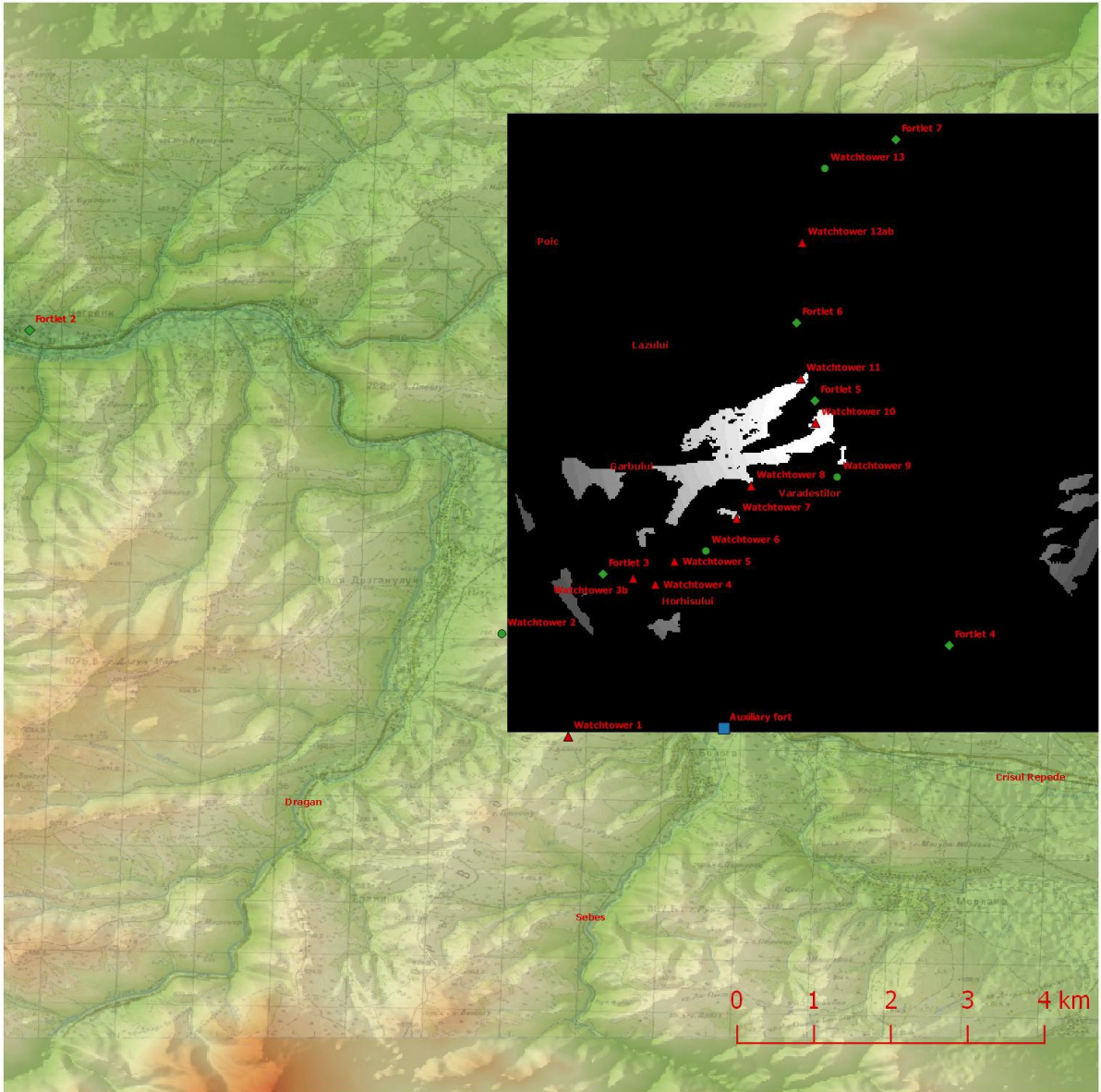

Figure 47. Watchtower 10 fuzzy viewshed with 1' visual arc (Resources and tools: GRASS; QGIS; Soviet Topographic Maps 1: 50 000; SRTM Global DEM - 30 m).



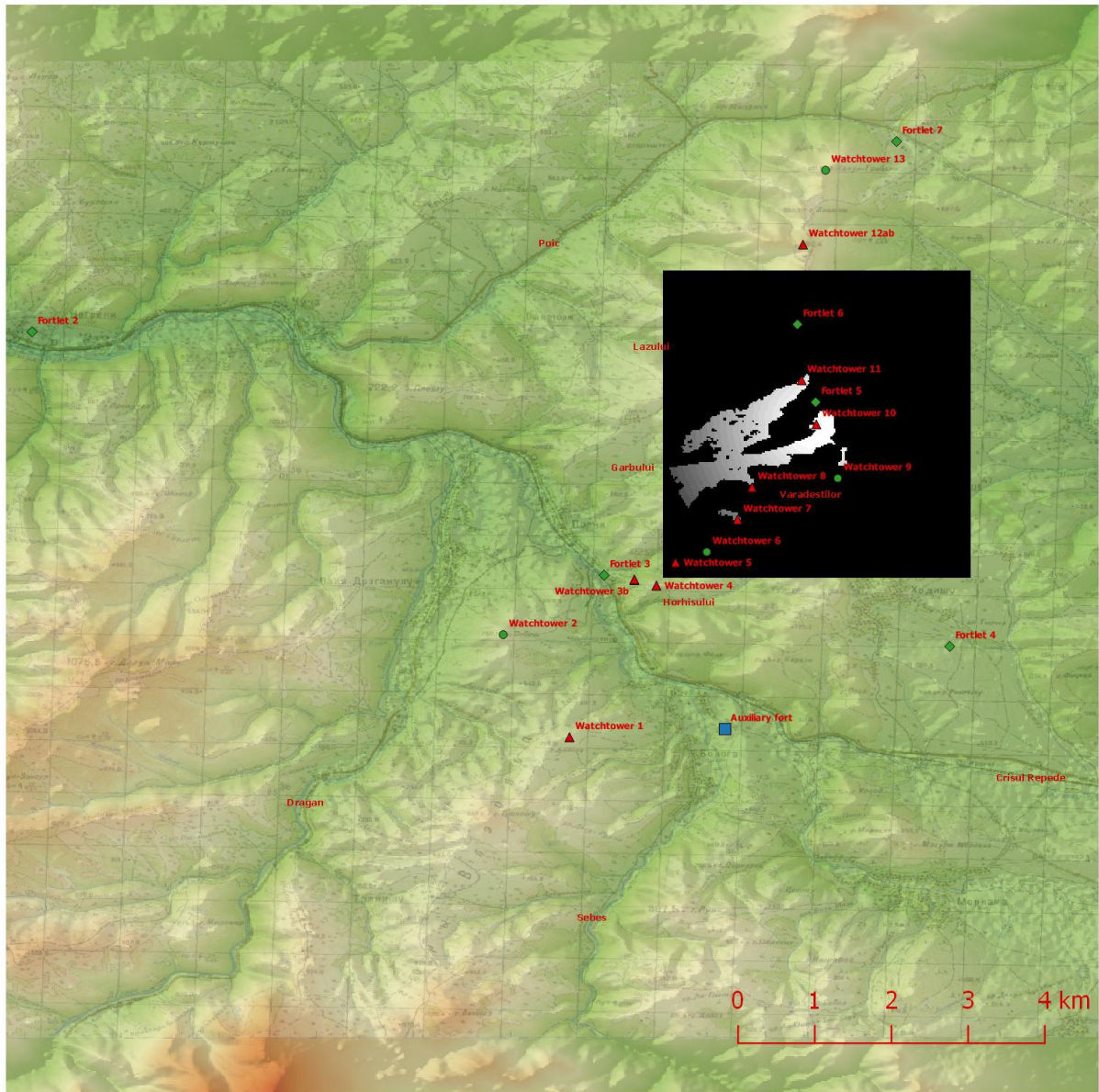

Figure 48. Watchtower 10 fuzzy viewshed with 2' visual arc (Resources and tools: GRASS; QGIS; Soviet Topographic Maps 1: 50 000; SRTM Global DEM - 30 m).

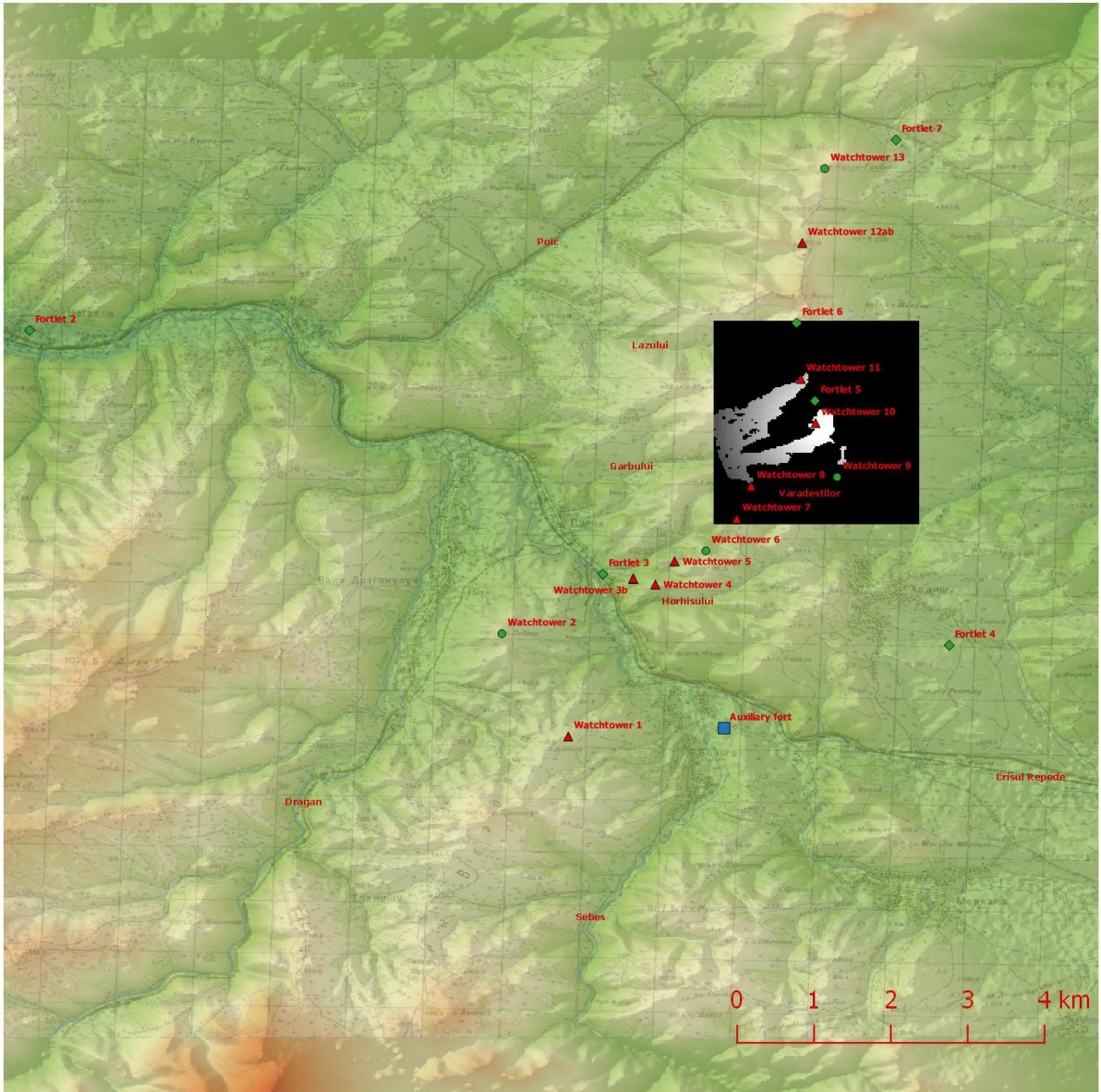

Figure 49. Watchtower 10 fuzzy viewshed with 3' visual arc (Resources and tools: GRASS; QGIS; Soviet Topographic Maps 1: 50 000; SRTM Global DEM - 30 m).



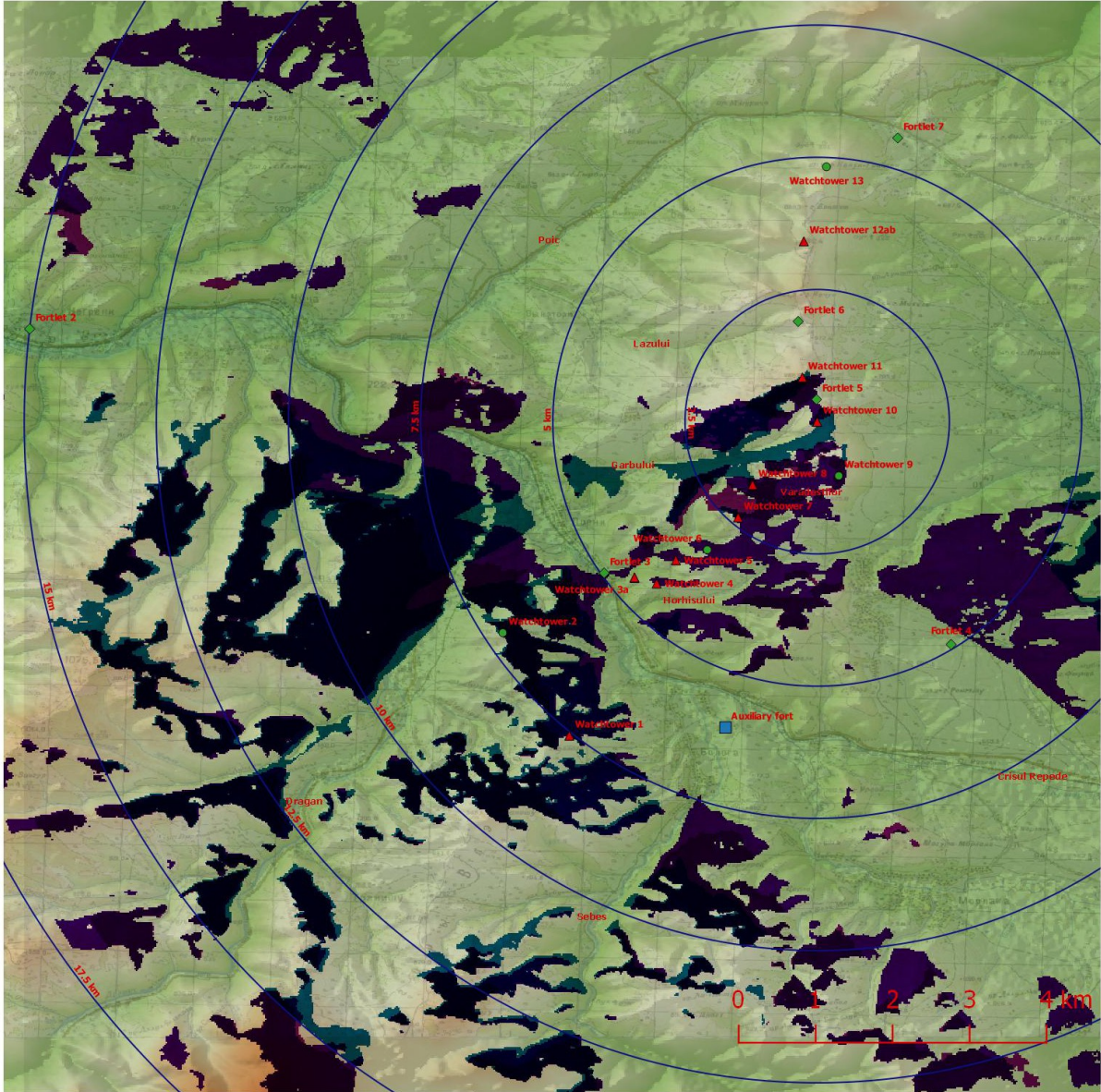

Figure 50. Watchtower 10's binary viewshed in comparison with Watchtower 7's and 8's (Resources and tools: GRASS; QGIS; Soviet Topographic Maps 1: 50 000; SRTM Global DEM - 30 m).



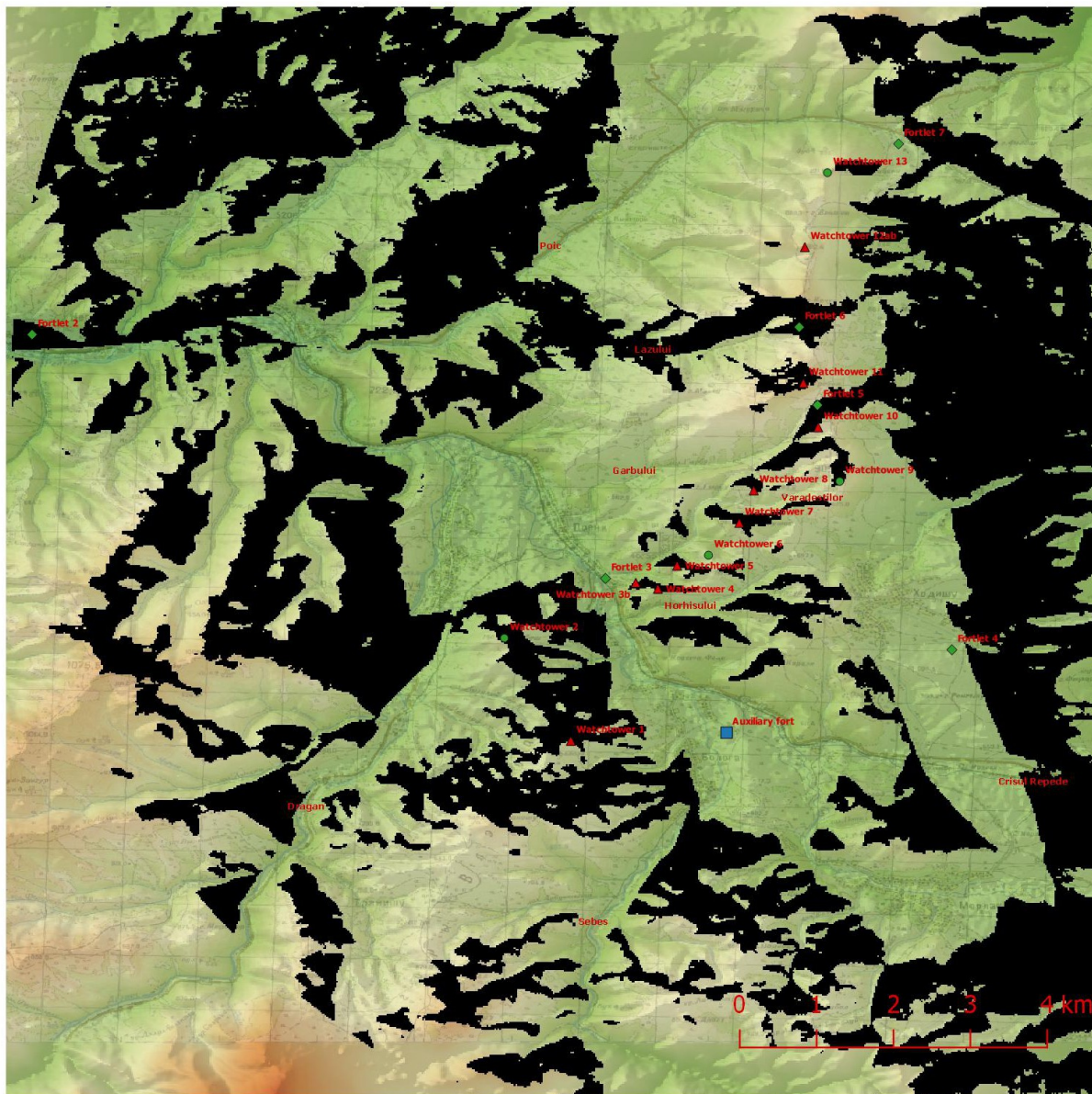

Figure 51. Watchtower 11 binary viewshed (Resources and tools: GRASS; QGIS; Soviet Topographic Maps 1: 50 000; SRTM Global DEM - 30 m).



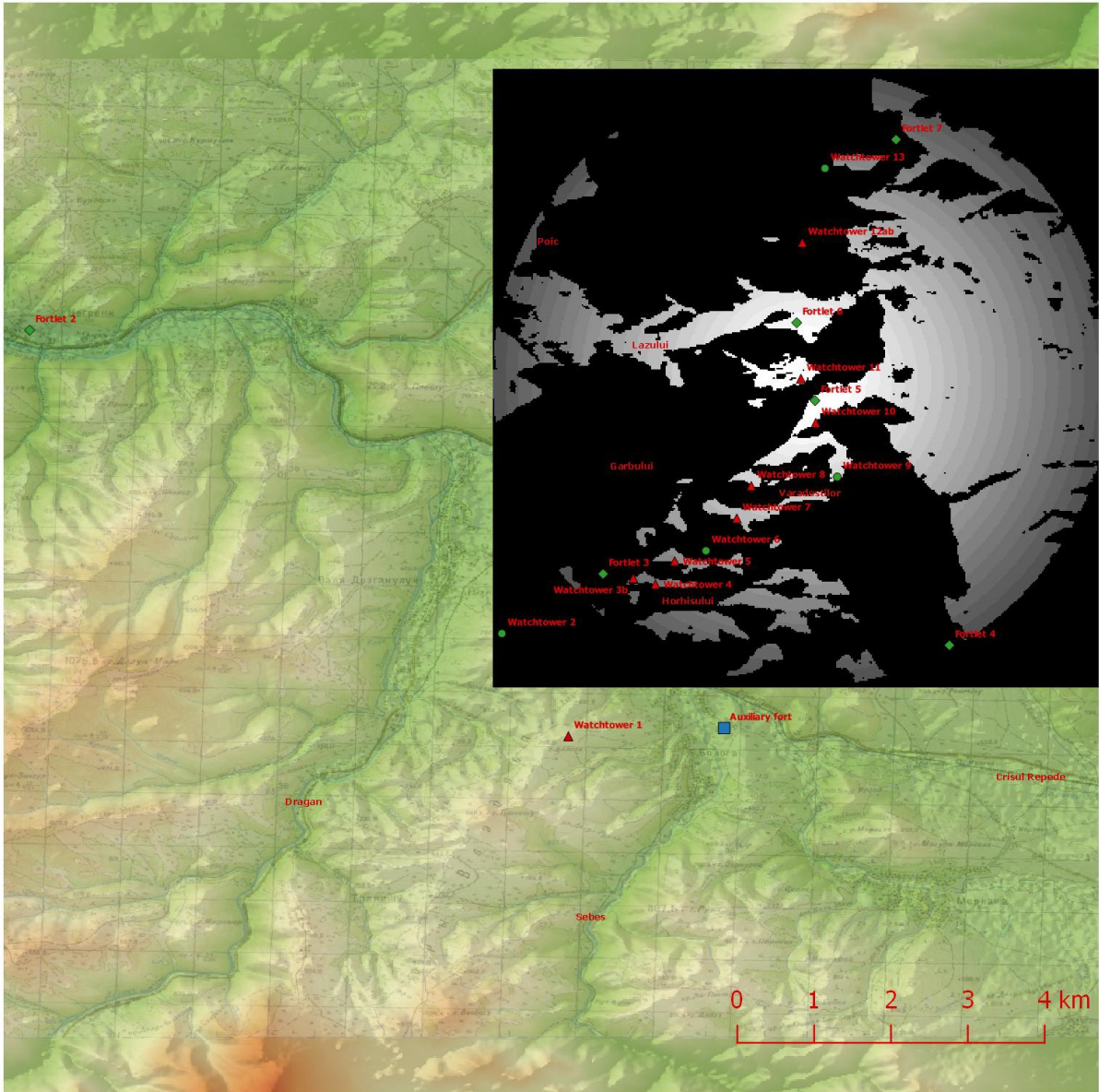

Figure 52. Watchtower 11 fuzzy viewshed with 1' visual arc (Resources and tools: GRASS; QGIS; Soviet Topographic Maps 1: 50 000; SRTM Global DEM - 30 m).

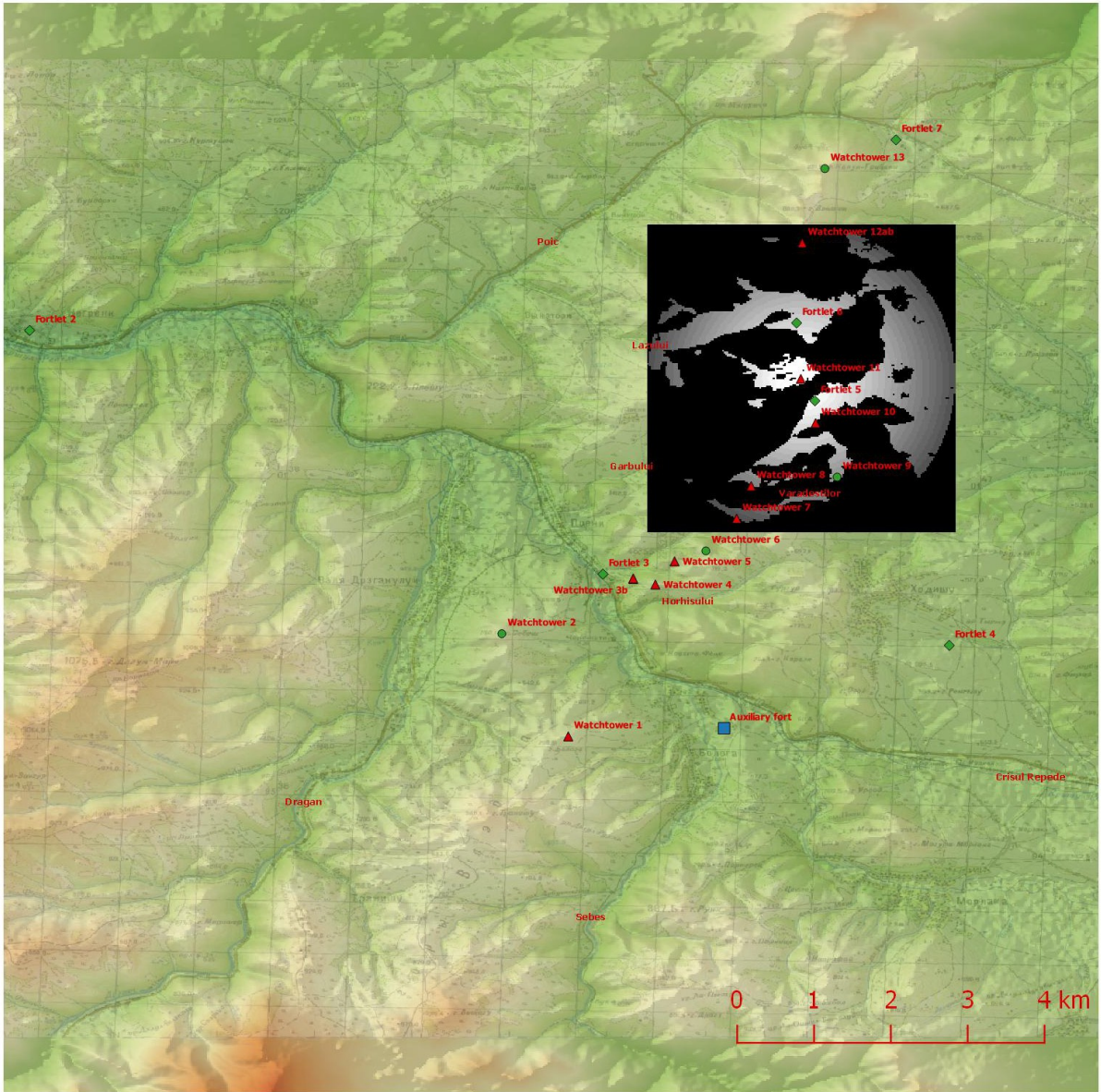

Figure 53. Watchtower 11 fuzzy viewshed with 2' visual arc (Resources and tools: GRASS; QGIS; Soviet Topographic Maps 1: 50 000; SRTM Global DEM - 30 m).



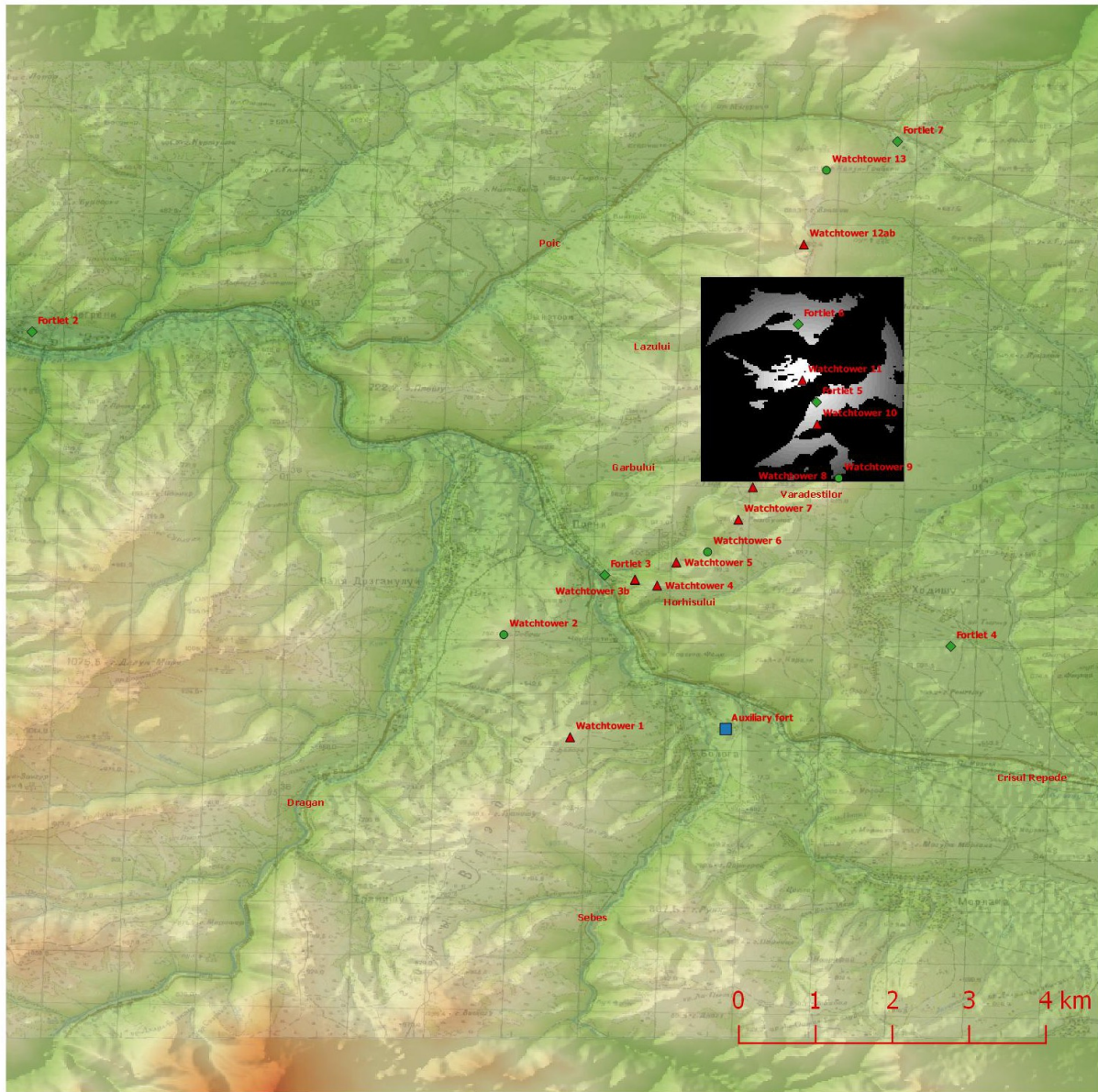

Figure 54. Watchtower 11 fuzzy viewshed with 3' visual arc (Resources and tools: GRASS; QGIS; Soviet Topographic Maps 1: 50 000; SRTM Global DEM - 30 m).



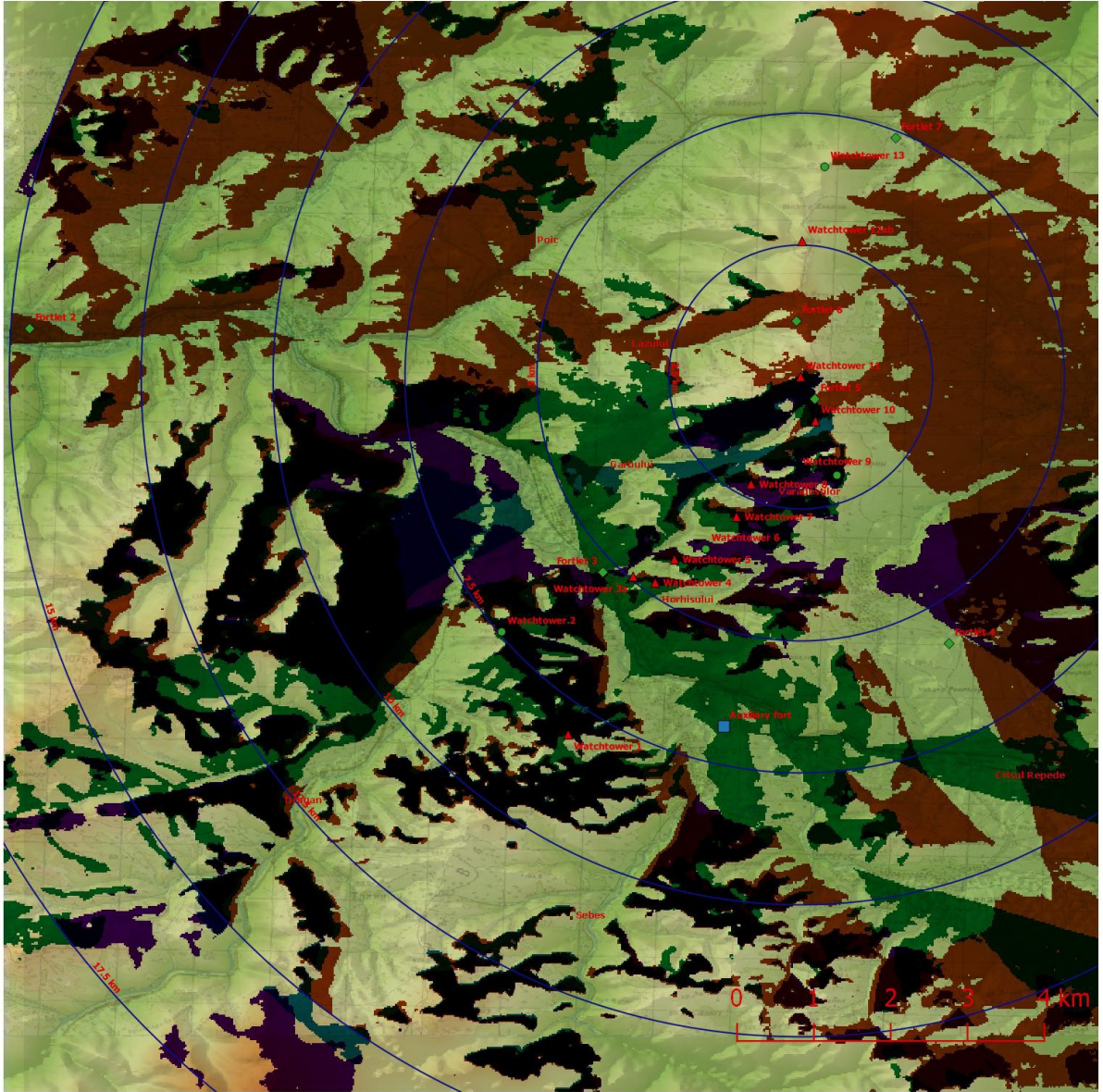

Figure 55. Watchtower 11's binary viewshed in comparison with Watchtower 1's, 7's and 10's (Resources and tools: GRASS; QGIS; Soviet Topographic Maps 1: 50 000; SRTM Global DEM - 30 m).



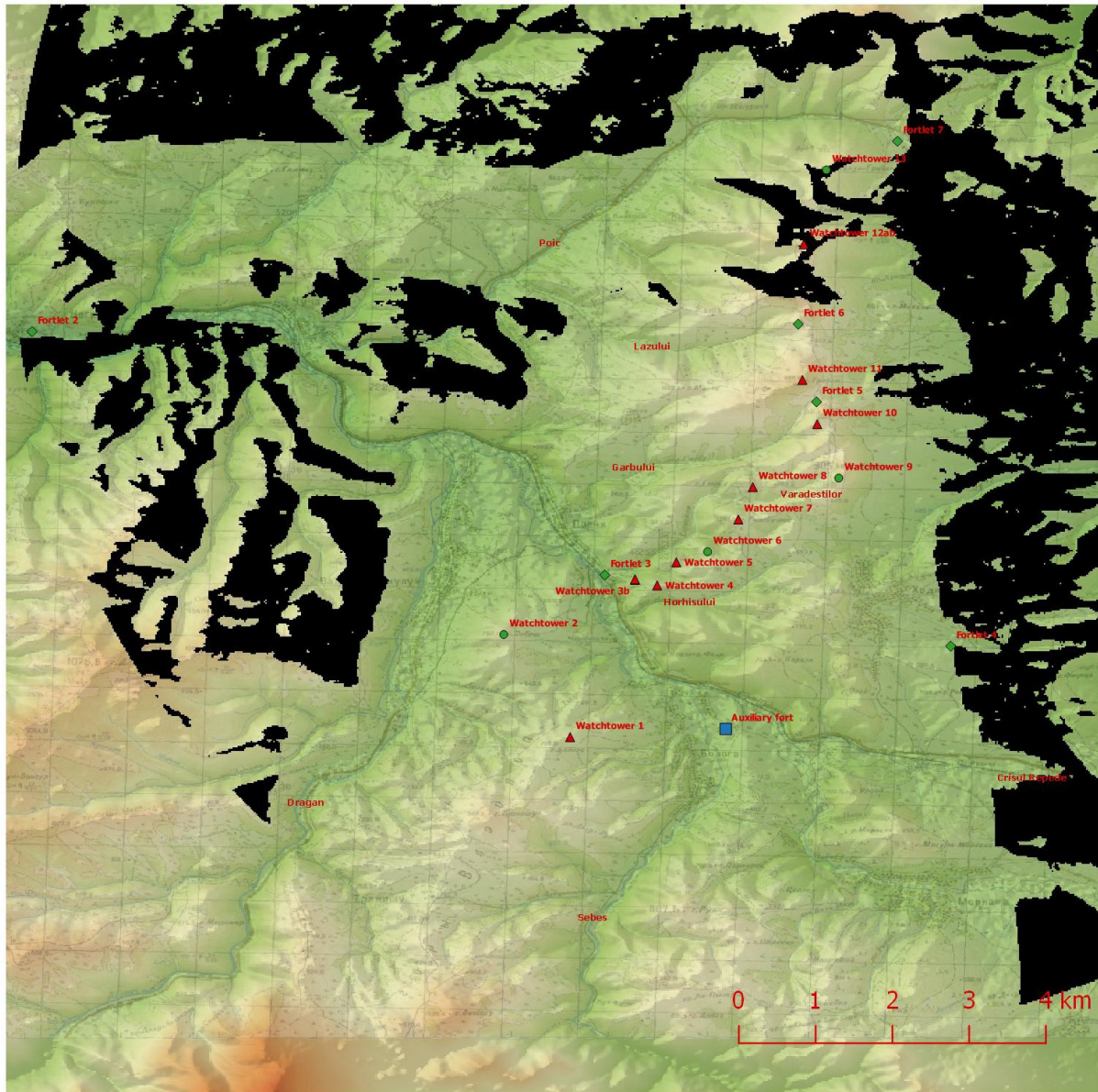

Figure 56. Watchtower 12b binary viewshed (Resources and tools: GRASS; QGIS; Soviet Topographic Maps 1: 50 000; SRTM Global DEM - 30 m).

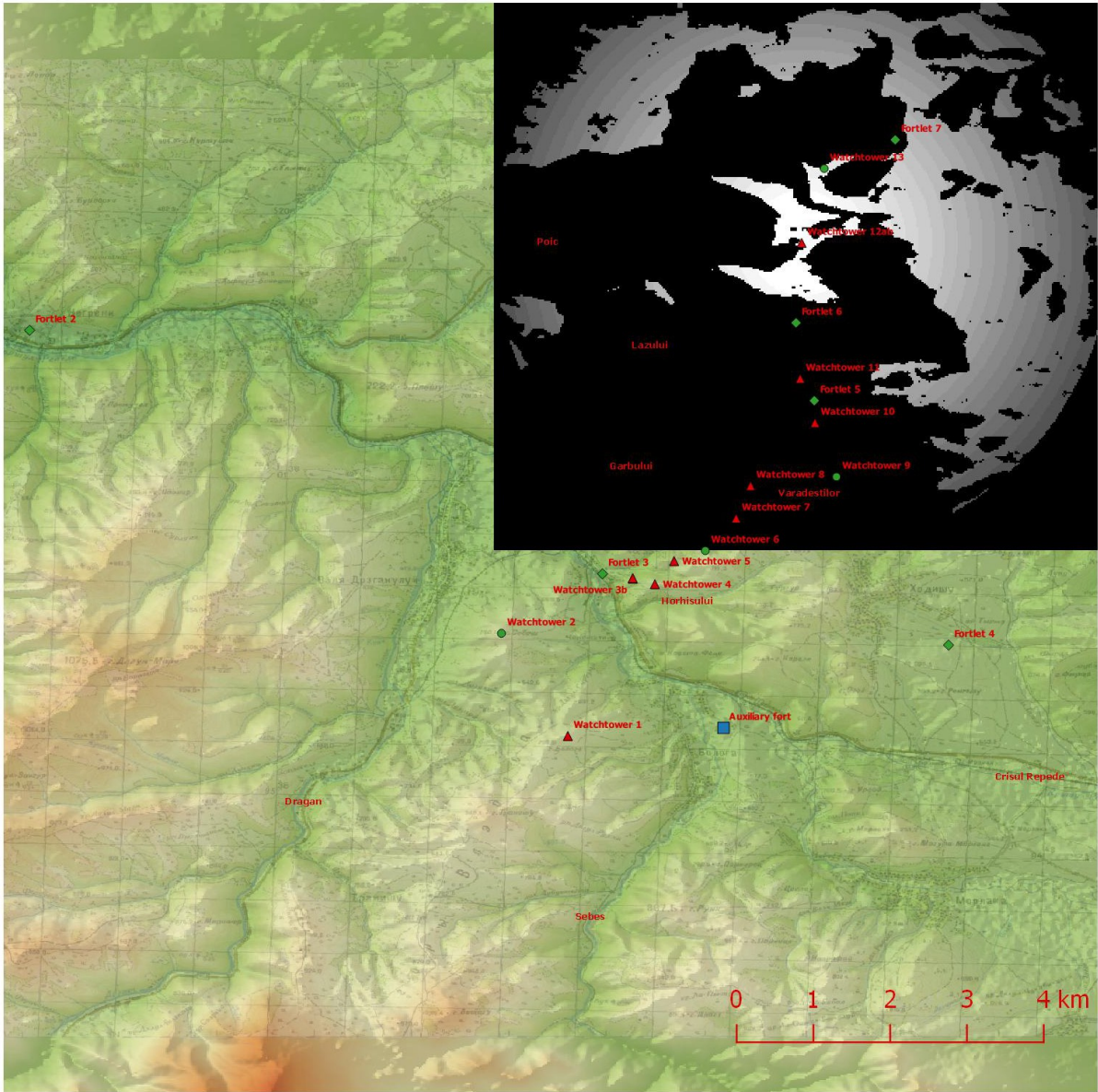

Figure 57. Watchtower 12b fuzzy viewshed with 1' visual arc (Resources and tools: GRASS; QGIS; Soviet Topographic Maps 1: 50 000; SRTM Global DEM - 30 m).



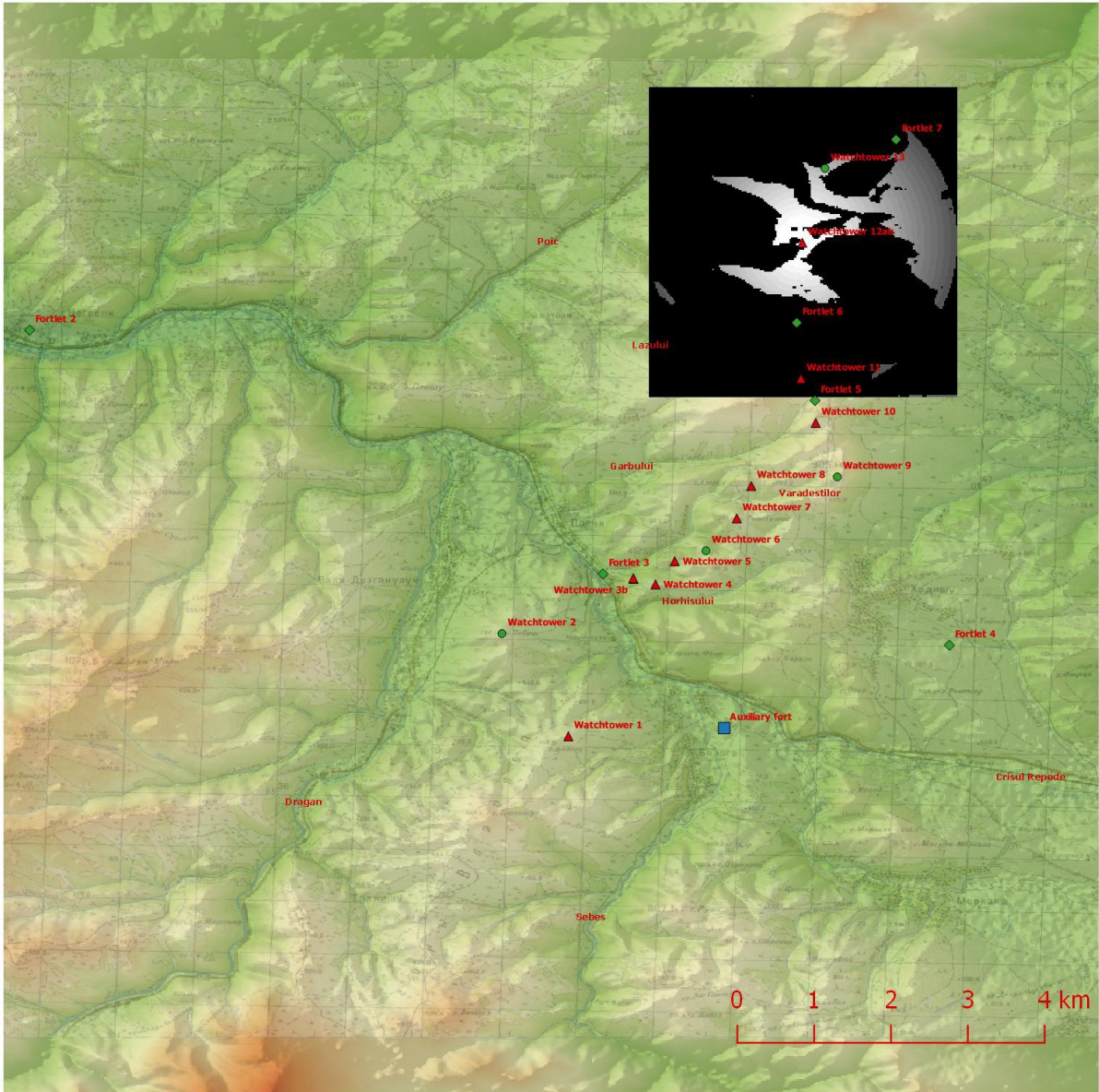

Figure 58. Watchtower 12b fuzzy viewshed with 2' visual arc (Resources and tools: GRASS; QGIS; Soviet Topographic Maps 1: 50 000; SRTM Global DEM - 30 m).

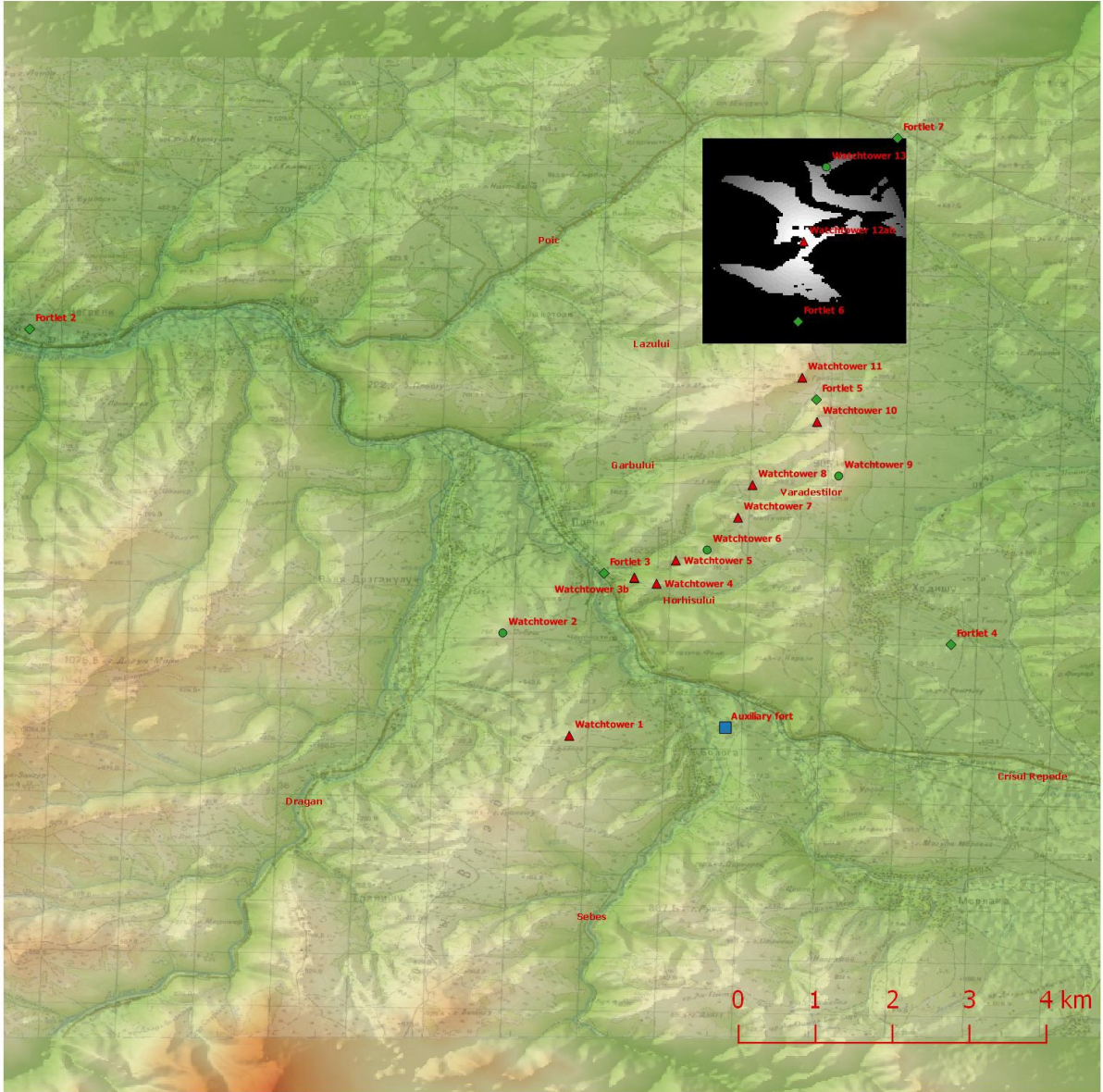

Figure 59. Watchtower 12b fuzzy viewshed with 3' visual arc (Resources and tools: GRASS; QGIS; Soviet Topographic Maps 1: 50 000; SRTM Global DEM - 30 m).



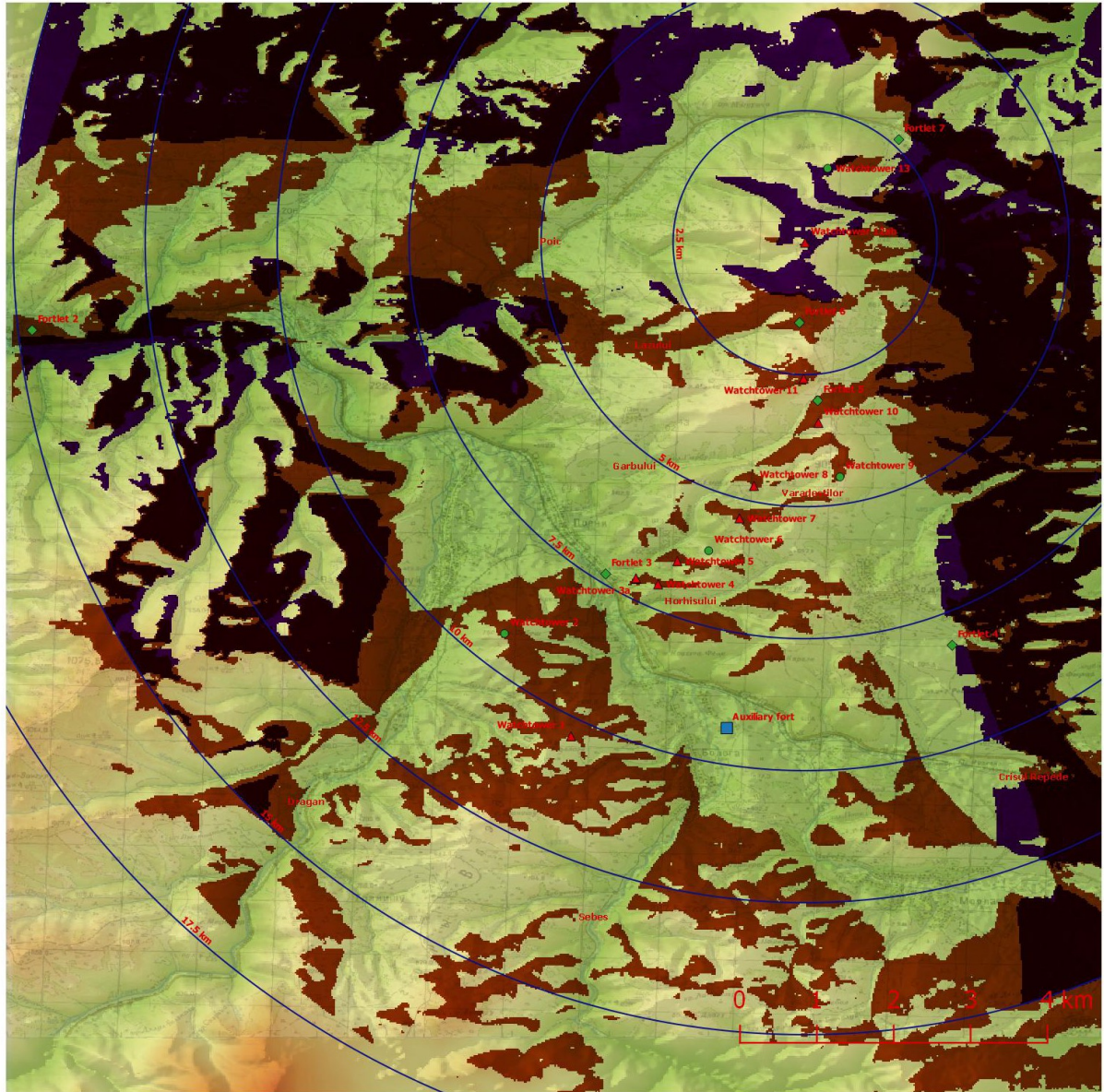

Figure 60. Watchtower 12b's binary viewshed in comparison with Watchtower 11's (Resources and tools: GRASS; QGIS; Soviet Topographic Maps 1: 50 000; SRTM Global DEM - 30 m).

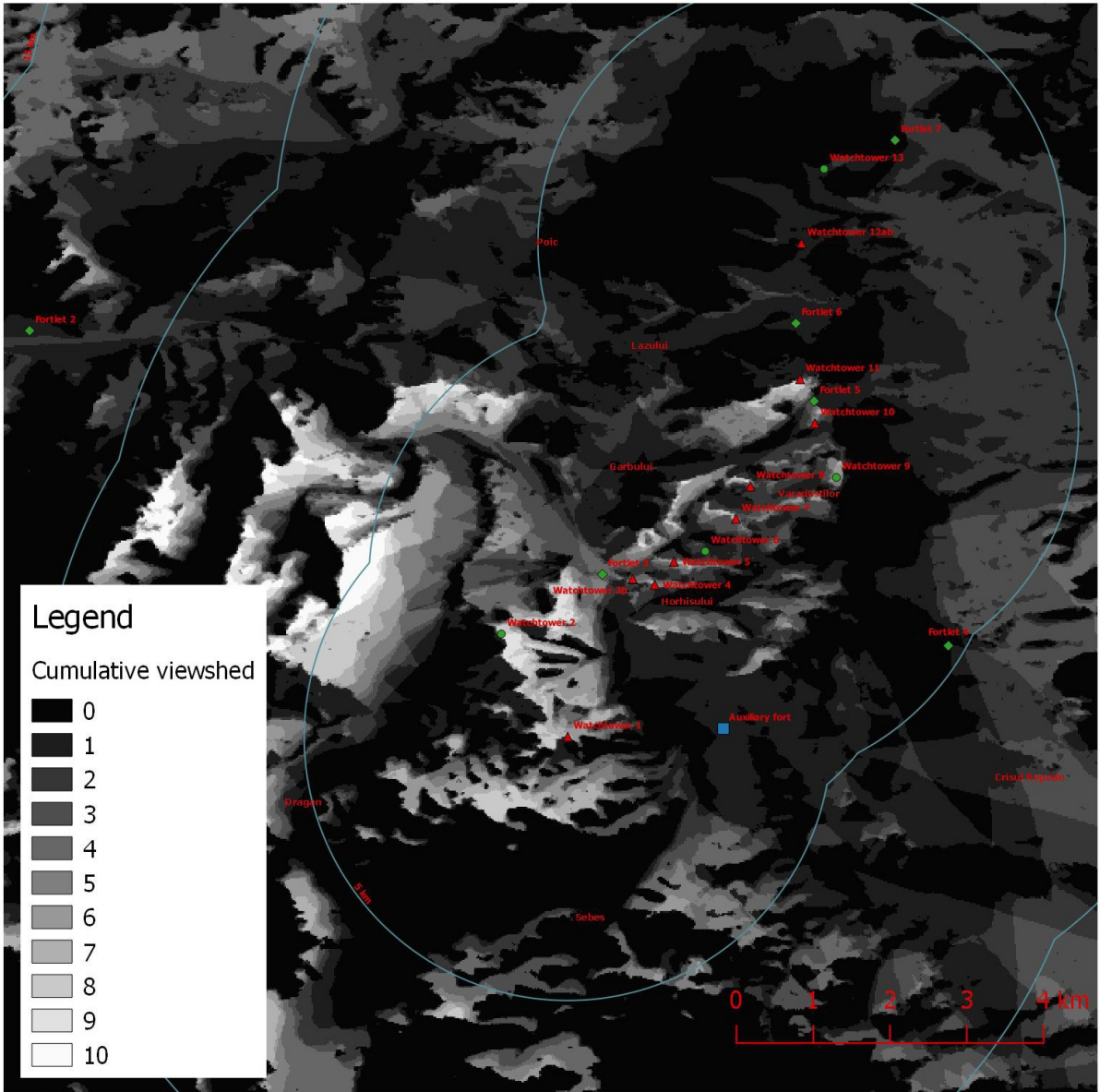

Figure 61. Cumulative viewshed. The legend indicates how many times a particular cell is visible from different positions (Resources and tools: GRASS; QGIS; SRTM Global DEM - 30 m).



The quantitative amount of visible land seen from each watchtower varied significantly. However, that fluctuated depending on the choice of range. The single viewsheds, within a range of 16 km, showed that Watchtower 11 could see the most, followed by Watchtowers 12b, 7, 1, 10, 8, 5, 4, 3a and 3b. However, a range of 16 km might only be relevant in special situations, where the stark object-background contrast would make the detection of far-away targets possible (fire and perhaps smoke signals). With the 1' visual arc threshold, within a range of 5.84 km, Watchtower 11 still held the first position, being followed by Watchtowers 12b, 1, 7, 4, 5, 3a, 3b, 8 and 10. With the 2' visual arc threshold, within a range of 2.92 km, Watchtower 4 could see the most, followed by Watchtowers 11, 1, 7, 12b, 3a, 5, 3b, 8 and 10. With the 3' visual arc threshold, within a range of 1.94 km, Watchtower 7 could view the most, followed by Watchtowers 4, 1, 11, 3a, 12b, 5, 8, 3b and 10. This means that in different visibility conditions, the efficiency of each watchtower differed, depending on the local terrain (Figure 62 and Table 2).

Observer sites	Amount of visible land (in number of raster cells) with different ranges			
	binary (16 km range)	1' arc (5.84 km range)	2' arc (2.92 km range)	3' arc (1.94 km range)
Watchtower 1	93910	33350	8490	4634
Watchtower 3a	18678	13242	5766	3135
Watchtower 3b	12639	8570	3474	1999
Watchtower 4	38804	23064	9162	4795
Watchtower 5	40664	17176	5725	2977
Watchtower 7	111525	24511	8427	5374
Watchtower 8	51212	6470	3189	2203
Watchtower 10	79333	5276	2766	1938
Watchtower 11	262341	41283	9133	3962
Watchtower 12b	193584	33731	5768	3078

Table 2. Number of visible cells found in the binary and fuzzy viewsheds. For the fuzzy viewsheds, all visible cells are considered equally visible in this case. It means that the fuzzy memberships are ignored here. The purpose of this was to see to what extent the choice of range affected the amount of visible land.

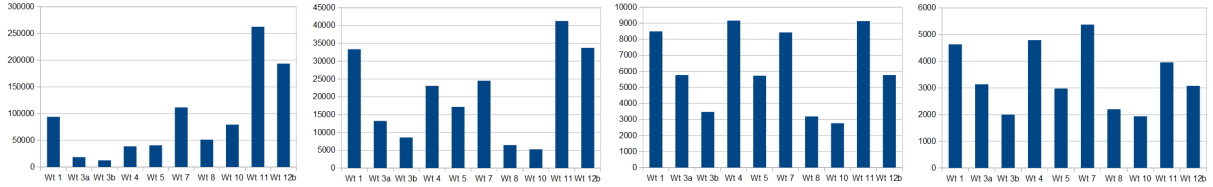

Figure 62. Comparison between all studied watchtowers' number of visible cells in the binary (first), fuzzy 1' visual arc (second), 2' visual arc (third) and 3' visual arc (last) viewsheds. In the fuzzy memberships, all visible cells are taken into account regardless of their fuzzy membership values. Wt. is for watchtower.

The intervisibility of sites was also very much dependent on the choice of range, which was meant to simulate different visibility conditions. In the 16 km range binary viewsheds, Watchtower 11 was intervisible with the highest number of sites, thirteen, followed by Watchtowers 1 with eleven, 7 with ten, 5 with nine, 4 with seven, 8 and 3a with five, 10 with four, 3b with three and 12b with one (Figures 63 and 67). With the 1' visual arc threshold, Watchtowers 11 and 7 could see the most sites, ten, followed by Watchtowers 5 with nine, 1 and 4 with seven, 3a with five, 8 with four, 3b with three, 10 with two and 12b with one (Figures 64 and 67). With the 2' visual arc threshold, Watchtower 7 was the most viewed tower, eight times, followed by Watchtowers 11 with six times, 5 with five times, 3a, 4 and 8 with three times, 3b and 10 twice, 1 and 12b once (Figures 65 and 67). With the 3' visual arc threshold, Watchtower 5 could view the highest number of sites, five, followed by Watchtowers 7 and 11 with three, 3a, 4 and 8 with two, 3b, 10 and 12b with one, but 1 with none (Figures 66 and 67). Intervisibility was also determined by the spacing of the sites. The fuzzy viewsheds illustrated relatively well how spacing affected the clarity of the observed targets. For example, where the watchtowers were more dense, more sites were intervisible within fuzzy memberships above 0.5 with the 2' and 3' visual arc thresholds. On the other hand, in areas where the sites were more distant, intervisibility occurred at lower fuzzy memberships or not at all. Overall, there was an extremely high degree of intervisibility between these sites, especially with the 16 km range, but also with the 5.84 km 1' visual arc threshold. Only a handful of sites could not be seen at all from any of the observer positions. That could be due to methodological reasons, or perhaps due to gaps in the archaeological knowledge. However, there were some problems even with the positive results. First of all, the study area represented only a small section of the entire *limes*. This meant that watchtowers with more centrality were able to see more sites than those located on the periphery. Secondly, some sites might originate from different chronological phases. In that case, intervisibility would have occurred to a lesser extent at some installations. Thirdly, there were a couple of sites that did not fall exactly inside the visible cells, but in the neighboring invisible ones. This could be caused by anything between the coarse resolution of the dataset, inaccurate elevation data, choice of target/observer heights, choice of viewshed algorithm, or perhaps somewhat imprecise mapping.



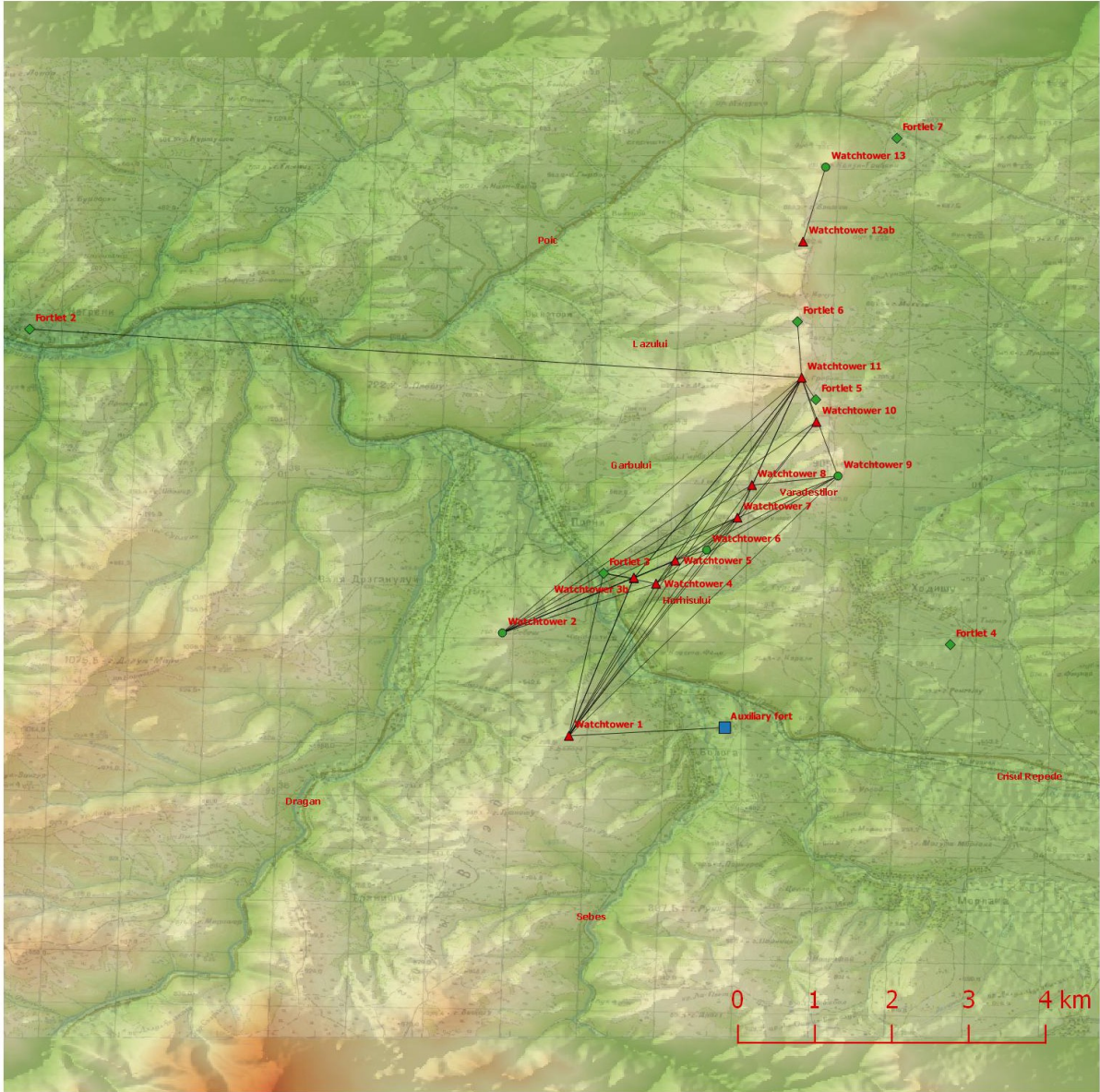

Figure 63. Binary viewshed intervisibility results (Resources and tools: GRASS; QGIS; Soviet Topographic Maps 1: 50 000; SRTM Global DEM - 30 m).



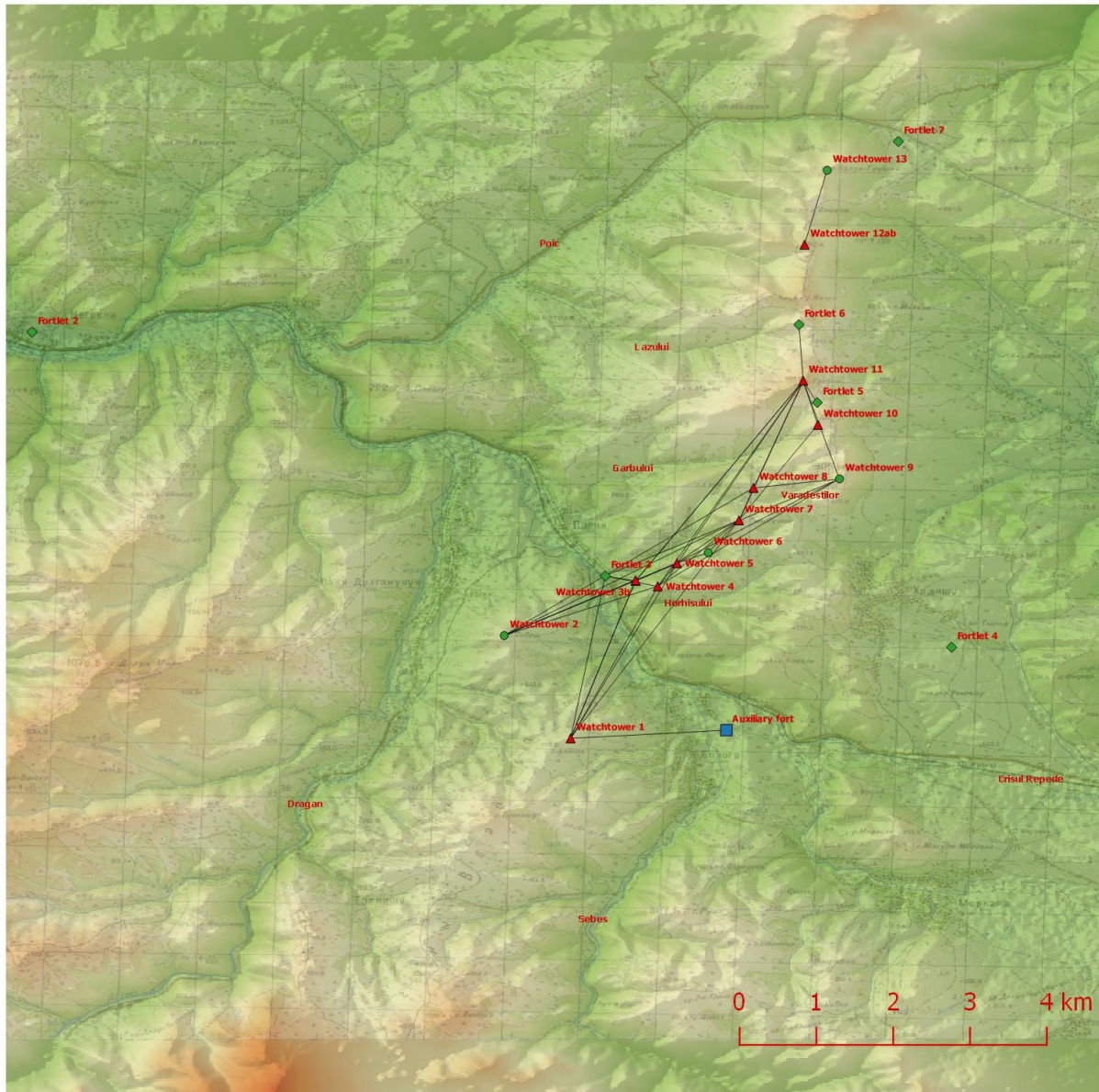

Figure 64. Fuzzy viewshed with 1' visual arc intervisibility results. It is marked for every tower that was within the maximum threshold regardless of the fuzzy membership (Resources and tools: GRASS; QGIS; Soviet Topographic Maps 1: 50 000; SRTM Global DEM - 30 m).



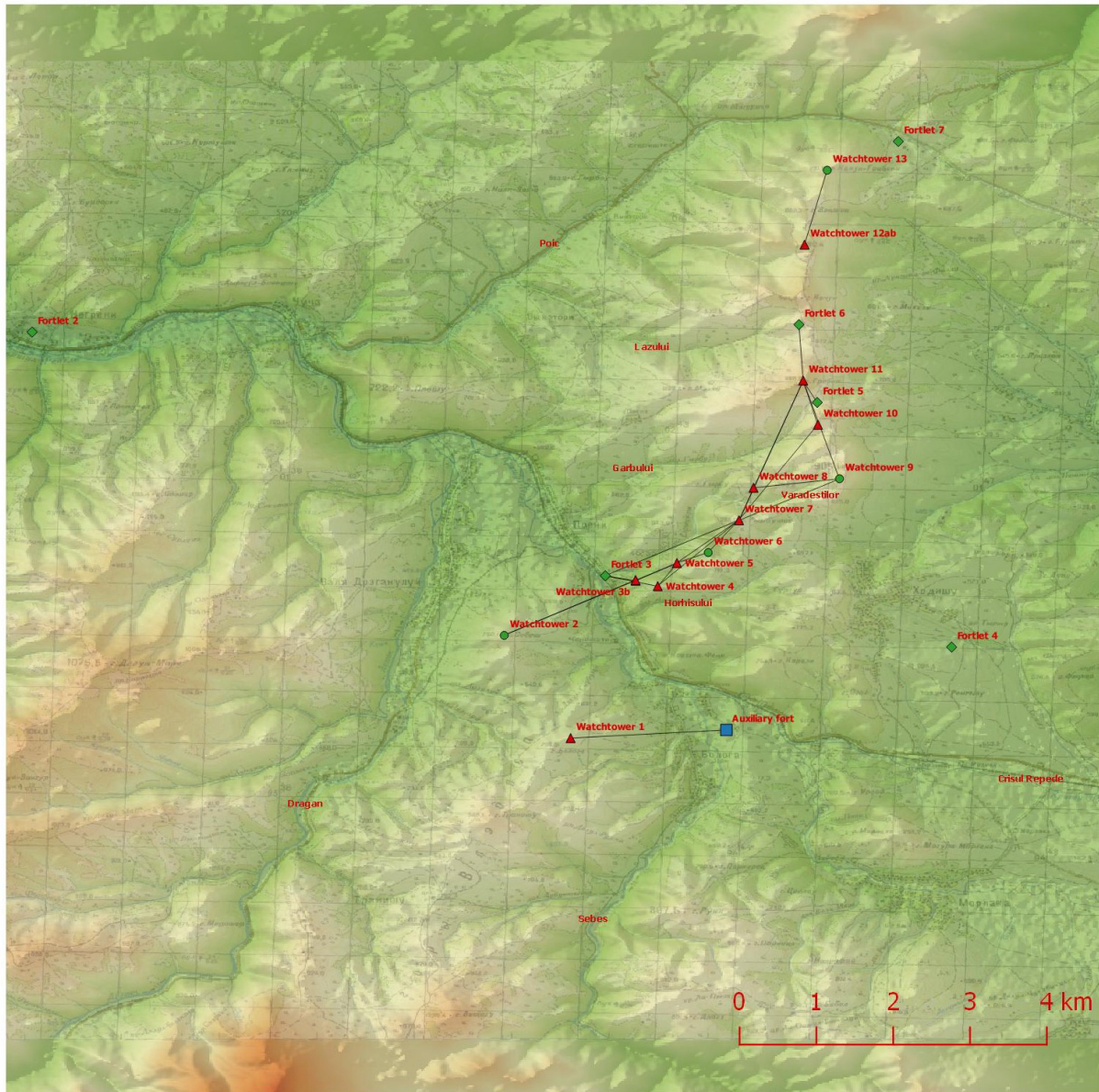

Figure 65. Fuzzy viewshed with 2' visual arc intervisibility results. It is marked for every tower that was within the maximum threshold regardless of the fuzzy membership (Resources and tools: GRASS; QGIS; Soviet Topographic Maps 1: 50 000; SRTM Global DEM - 30 m).



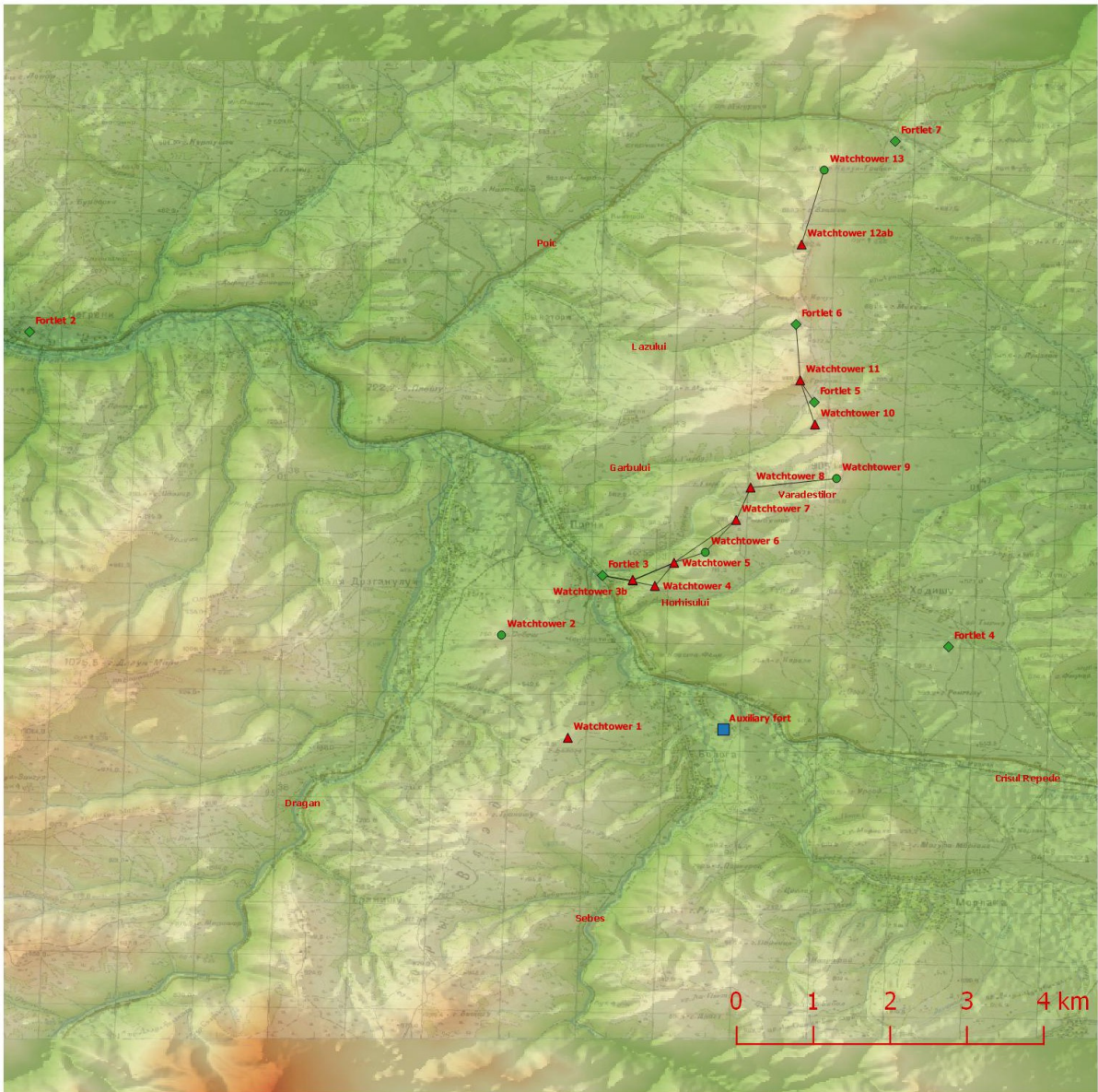

Figure 66. Fuzzy viewshed with 3' visual arc intervisibility results. It is marked for every tower that was within the maximum threshold regardless of the fuzzy membership (Resources and tools: GRASS; QGIS; Soviet Topographic Maps 1: 50 000; SRTM Global DEM - 30 m).

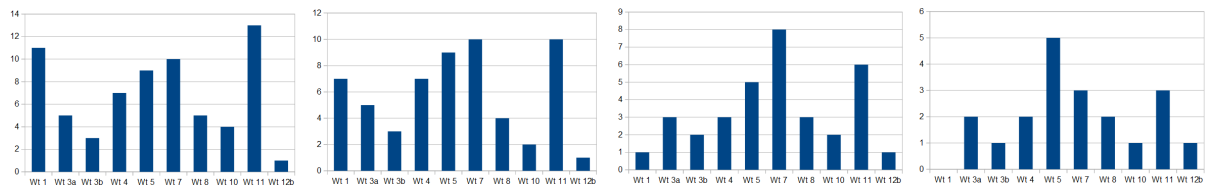

Figure 67. Comparison between the number of visible watchtowers from each studied structure. The results were obtained from the binary (first), fuzzy 1' visual arc (second), 2' visual arc (third) and 3' visual arc (last) viewsheds. In the fuzzy viewsheds, all visible towers are taken into account regardless of their level of clarity.



		Target sites (with certainty levels 1-4), where A F = auxiliary fort, F = fortlets, Wt = watchtowers																					
		AF	F 2	F 3	F 4	F 5	F 6	F 7	Wt 1	Wt 2	Wt 3a	Wt 3b	Wt 4	Wt 5	Wt 6	Wt 7	Wt 8	Wt 9	Wt 10	Wt 11	Wt 12 a / b	Wt 13	
Observer sites - binary (b) / fuzzy (f) 1' arc, 2' arc, 3' arc	Watchtower 1	b	1	0	1	0	0	0	0	0	1	1	1	1	0	1	1	1	1	1	0	0	
		1'	0.7		0.7						0.666	0.666	0.666	0.6		0.4							
		2'	0.333																				
		3'																					
	Watchtower 3a	b	0	0	1	0	0	0	0	1	1			0	1	0	0	0	0	0	1	0	0
		1'			1				0.666	0.733					1						0.433		
		2'			0.966					0.366					0.866								
		3'			0.866										0.766								
	Watchtower 3b	b	0	0	0	0	0	0	0	0	1			0	1	0	0	0	0	0	1	0	0
		1'								0.733					1						0.433		
		2'								0.366					0.866								
		3'													0.766								
	Watchtower 4	b	0	0	1	0	0	0	0	1	1	0	0		1	0	1	0	1	0	1	0	0
		1'			0.966					0.666	0.7				1		0.833		0.566		0.466		
		2'			0.833										0.966		0.566						
		3'			0.7										0.866								
	Watchtower 5	b	0	0	0	0	0	0	0	1	1	1	1	1		1	1	0	1	0	1	0	0
		1'								0.6	0.633	1	1	1		1	0.933		0.633		0.533		
		2'										0.866	0.866	0.966		0.933	0.733						
		3'										0.766	0.766	0.866		0.866	0.533						
	Watchtower 7	b	0	0	1	0	0	0	0	1	1	0	0	1	1	1		1	1	1	1	0	0
		1'			0.733					0.4	0.433			0.833	0.933	1		1	0.833	0.8	0.733		
		2'			0.366									0.566	0.733	0.9		0.933	0.566	0.466	0.333		
		3'													0.533	0.766		0.833					
	Watchtower 8	b	0	0	0	0	0	0	0	1	1	0	0	0	0	0	1		1	0	1	0	0
		1'								0.366							1		0.9		0.8		
		2'														0.933		0.666		0.5			
		3'														0.833		0.433					
	Watchtower 10	b	0	0	0	0	0	0	0	1	1	0	0	0	0	0	1	0	0		1	0	0
		1'															0.8				1		
		2'															0.466				0.866		
		3'																			0.733		
	Watchtower 11	b	0	1	0	0	1	1	0	1	1	1	1	1	0	1	1	1	1	1		0	0
		1'					1	0.966				0.433	0.433	0.466	0.533		0.733	0.8	0.833	1			
		2'					1	0.833									0.333	0.5	0.566	0.866			
		3'					0.933	0.666												0.733			
Watchtower 12b	b	0	0	0	0	0	0	0	0	0	0	0	0	0	0	0	0	0	0			1	
	1'																					0.933	
	2'																					0.733	
	3'																					0.5	

Table 3. Binary and fuzzy viewshed intervisibility results. For binary viewsheds, 1 is for visible, whereas 0 is for invisible. For fuzzy viewsheds, the values represent the clarity of viewed targets, where the higher the number, the more visible they are. Grey cells are for targets that were either invisible, or for those that fell outside the maximum threshold. Dark-grey cells are so because they are irrelevant.

### 3. Discussion

This chapter is divided into five parts. In the first subchapter, the arrangements of the sites appearing in this study area, and how that might have affected their relationships are dealt with. Next, various forms of communication which might have been employed are discussed. After that, the people responsible for operating these defences are presented. The second-to-last part places the studied defensive system within a provincial context. The final section contains some closing remarks on *limites* in general.

#### 3.1. The local defensive system

The auxiliary fort near modern-day Bologa was located on a plateau sloping northwest, at the confluence of the Crișul Repede and Sebeș. Such sites were used for housing multiple detachments amounting to one or more auxiliary units, but were usually smaller than legionary fortresses.<sup>59</sup> Its positioning was probably not accidental because rivers often provided cheap means of transporting large quantities of supplies<sup>60</sup>, whereas the plateau could have prevented flooding to some extent. Apart from these, there were other conditions as well that would usually determine their placement, like the presence of firewood, drinking water, salubrity of the area, etc.<sup>61</sup> The first occupation of this auxiliary fort probably dates to Trajan's reign, like the one from Buciumi, both being attributed to the so-called *Meseș limes*. Although the internal planning from this phase is scarcely known, some small finds dating from that period were found.<sup>62</sup>

It is thought that the Roman army of the Principate preferred not to be besieged. A more offensive approach to warfare was favored whenever possible, although its marching speed and entrenching practices seemed to contradict that. Whether on offense or defense, whether in friendly or enemy territory, entrenching and building marching camps was the standard norm. However, the fortifications they hastily erected were not impressive. Although they might have been sufficient to repel surprise attacks in most situations, they were not meant to withstand prolonged sieges.<sup>63</sup> In the Western empire, some of the camps they occupied slowly turned into permanent sites. Some of them were gradually rebuilt in stone, usually from the Flavian period onwards, but their defenses remained relatively modest. As the enemy incursions multiplied by the third century, their deficiencies started to be revealed by construction changes or abandonments. The newly emerged and much better fortified towns

---

59 Hanel 2007, pp. 407-408; Gudea 1997, pp. 17, 21. There was a lot of variation when it came to military camp dimensions. A legionary fortress housing one legion required 18-24 hectares. For housing one auxiliary infantry unit, 1.4-3.2 hectares were necessary, or up to 6.1 for one auxiliary cavalry unit. At Bologa, the site was initially 1.9 hectares, being expanded later to 3.05. The dimensions of these sites varied depending mainly on the number of soldiers that required accommodation.

60 Roth 1999, pp. 196-197.

61 Vegetius, 1.22.

62 Gudea 1997, p. 19; Marcu 2006, pp. 153-157.

63 Goldsworthy 1996, pp. 25-26, 111-115.



of the third-fourth centuries also proved how inadequate the old forts were.<sup>64</sup> Therefore, it is assumed that some kind of warning system might have been in place throughout this period, where tower-looking outposts provided visual support to these military sites.

In this study area, the only tower that could directly see the Auxiliary fort was Watchtower 1. In another corner of the Empire, something similar was found<sup>65</sup>, but elsewhere that was not the case.<sup>66</sup> The placement of the fort and the local topography offered a limited view over the surrounding area<sup>67</sup>, and would have required the need for warning even more. In this case, it happened that only Watchtower 1 was capable of doing that. This means that the structure had one of the most important roles within the local defensive system, and was perhaps also one of the oldest towers in the area. Located west of the fort, it had one of the widest visual coverage, in all analyzed visibility conditions. Moreover, it was also intervisible with one of the largest number of sites, but only in the binary viewsheds.<sup>68</sup> With 1' visual arc, it could recognize individual 1.7 m sized targets from the Auxiliary fort at a fuzzy membership of 0.7, which is theoretically above the borderline clarity of 0.5. However, with 2' visual arc, probably only detection would have been possible at a fuzzy membership of 0.333. With 3' visual arc on the other hand, detection would have been even more difficult, if possible at all. Its view over the surrounding area was not entirely complete however, reason why it was complemented with other towers' viewsheds. Since no towers are known to the south, Watchtower 1 probably communicated with Watchtower 2 to the northwest, or with any of the many sites located northwards. Watchtower 2 is rather uncertain archaeologically. Yet the distance between it and Watchtower 1 would have made it slightly easier to spot than the Auxiliary fort.

Watchtowers 3a and 3b could partly fulfill the role of complementing Watchtower 1's view over the western parts, from where the enemy was most expected to appear. Considering their proximity, probably the two towers were from different phases, where Watchtower 3a is thought to be the younger.<sup>69</sup> The supposedly younger structure had better visual coverage than the older one, but compared to all other towers, it was medium at best with 3' visual arc. A better candidate to Watchtowers 3a or 3b would have been Watchtower 4 because it could see more land. It could complement almost completely Watchtower 1's view to the west. All three towers, Watchtowers 3a, 3b and 4, with 1' visual arc could recognize the guard standing on Watchtower 1 at a fuzzy membership of 0.666. With 2' and 3' visual arcs however, it would have been less possible, as between Watchtower 1 and the Auxiliary fort. Intervisibility between any of these three towers with Watchtower 2 would not have been easier. It is unclear if Watchtower 3a preceded Watchtower 4 or not, considering that the latter theoretically fared

---

64 Hanel 2007, pp. 399-401.

65 Hodgson 1993, p. 96. The Roman fort at Fendoch, Scotland, was assisted by a tower overlooking the Sma' Glen. However, it was not part of a linear type of defensive system because it was only an individual tower.

66 Woolliscroft 1993, p. 297. Both Parkneuk and Westerton towers were intervisible with Strageath fort, also on the Gask ridge, Scotland. These were part of a defensive system arranged in linear fashion.

67 Marcu and Cupcea 2013, p. 576. It was demonstrated through viewshed analysis.

68 Marcu and Cupcea 2013, pp 576-578. Watchtower 6 was visible too in this case. However, the position of Watchtower 1 differs in their study, as stated in the 1.2. Research history. Nevertheless, the intervisibility results were the same for all the other sites, despite them using higher observer heights (8 m) and longer ranges (20 km).

69 Gudea 1971, p. 528.

better. Watchtowers 1 and 4 might have been enough to visually cover a good chunk of the area between the Auxiliary fort and the left bank of the Drăgan valley, including the entrance to the Vărădeștilor valley guarded by Fortlet 3. However, Watchtowers 3a and 3b could see up to 500 m inside that valley, on both sides.

Watchtowers 5, 7, 8 could all look down in that valley, along with Watchtowers 3a and 3b, managing to visually cover the entire length of the valley completely. For this reason, probably they were all built for the same purpose, considering that they were complementing each others' views rather well inside the Vărădeștilor valley. All three towers could also see on the other side of the valley to some extent, over the ridge, the northern bank of the Gârbului valley running parallel with the Vărădeștilor one. Clarity over these areas would have been relatively satisfactory because fuzzy memberships were above 0.5, but only with 1' visual arc. Their maximum ranges in those directions were restricted by the terrain. However, the local topography formed with these two parallel valleys a natural obstacle resembling a double ditch, which might have slowed down movements coming from that direction. Their views over the right bank of the Gârbului valley were overlapping rather than complementing each other however. While Watchtower 1 could also see a sizeable and almost complete portion of that area, the visibility would have occurred below 0.333 fuzzy membership even with 1' visual arc. All watchtowers surveying the Vărădeștilor valley, like 3a/3b 5, 7 and 8, could complement each others views over the entire section of this corridor, while almost all of them being intervisible with one another. Due to how closely spaced they were, Watchtowers 5 and 7 for example could recognize targets standing as far as on the second neighboring towers at fuzzy memberships above 0.5, even with 3' visual arc. Areas with such high density of watchtowers were not uncommon, but there were considerable variations.<sup>70</sup> Although some of these towers could theoretically be intervisible with Watchtower 1 as well, the targets would have stood at 0.666-0.4 fuzzy memberships, and only with 1' visual arc. It is unclear in this study what the purpose of less certain towers were (level 3), like Watchtowers 6 and 9<sup>71</sup>, as 3a/3b 5, 7 and 8 could already complement each others views inside the Vărădeștilor valley. However, both Watchtowers 6 and 9 were within reasonable ranges of clarity from any of the neighboring intervisible towers, at fuzzy memberships above 0.5, except with 3' visual arc.

While the view over the Gârbului valley was limited to the northern bank from these towers, the southern side was visible from Watchtower 10. Viewing both sides and thus complementing one another's views was important here, but in other similar situations too, because invisible areas could theoretically have been used by the enemy to regroup and change the course of action. Watchtower 10 could recognize targets standing on Watchtower 7 for example at fuzzy memberships above 0.5, except with 3' visual arc. This tower could also see Watchtower 11 located immediately to the north, on the other side of the Gârbului valley, at fuzzy memberships of much above 0.5, even with 3' visual arc. The latter tower, had the

---

70 Hodgson 1993, p. 85-88. The Taunus sector on the Germanic *limes* was denser in watchtowers compared to the eastern Wetterau sector from the same frontier, or the Gask ridge one, especially during Trajan's reign.

71 Marcu and Cupcea 2013, pp 578, 580. In their analysis, Watchtower 6 had the same visual coverage as 5.

Watchtower 9 basically overlapped Watchtowers 7 and 8's views inside the Vărădeștilor valley, but could see much land on the eastern and southern side, with Fortlet 4 being very likely visible from there.



best visual coverage of all the studied towers, but with 3' visual arc for example, its efficiency probably would have been above average. It was intervisible with all towers except Watchtower 6.<sup>72</sup> However, Watchtowers 5, 7, 8, 9 and 10 were visible within fuzzy memberships above 0.5, and only with 1' visual arc. With 2' visual arc, only those as far as Watchtower 8 were above that value, whereas with 3' visual arc, only Watchtower 10 was. Watchtower 11 could see on the western side as far as the Poic valley. However, at that distance, even with 1' visual arc, the targets would have been visible at fuzzy memberships below 0.333. On the northern side, although Watchtower 11 could see the right bank of the Lazului valley, it could not see over it. Moreover, the southern side of the valley, on which the tower was located, had insufficient visual coverage. Additionally, although there were other known watchtowers northwards, they were not intervisible with this one. For these reasons, another tower would have been necessary on northern side of the Lazului valley. That might have complemented this ones views, but also linked it with the others to the north. Without a tower in this location, a visual gap would have existed within the *limes* in this section.

The remaining Watchtower 12b likewise displayed a wide visual coverage under every condition, but it was always slightly below Watchtower 11's. It could see just as far as the latter tower, with the same visual clarity. However, it complemented Watchtower 11's view over the right bank of the Poic valley at the same time. It is also worth reminding that there were two towers close to each other in this position, Watchtowers 12a and 12b, much similar to the Watchtowers 3a and 3b case. The only site that was intervisible with Watchtower 12b was Watchtower 13, which would have occurred in every condition above 0.5 fuzzy membership. However, the latter tower is archaeologically uncertain.

Fortlets were smaller scale versions of auxiliary forts, yet they were bigger than typical watchtowers. Their size seems to indicate that they were used for housing only a couple of *centuriae*, meaning no more than a few hundreds.<sup>73</sup> Their purpose was to serve as minor bases, from where frontier patrols and the operation of watchtowers could be carried out. In some cases it was hypothesized that some might have acted as customs collecting points as well.<sup>74</sup> Fortlets were very often found near rivers, streams, valleys, passes, and were placed in proximity to watchtowers.<sup>75</sup> Although there is no clear archaeological evidence here, their closeness to the Auxiliary fort might indicate that their garrisons consisted of detachments relocated from there.<sup>76</sup> In this study area, Fortlet 3 was located northwest from the Auxiliary fort, on the northern bank of the Crișul Repede, at the entrance to the Vărădeștilor valley. It was visible from Watchtower 1, at 0.7 fuzzy membership with 1' visual arc, just like the

---

72 Marcu and Cupcea 2013, p. 580. It was intervisible with Watchtower 6 as well, but not with Watchtowers 3a, 3b and 4. In their analysis, they used lower observer heights (8 m) than the one I used for this tower in my study (9.6 m).

73 Hanel 2007, p. 408; Hodgson 1993, pp. 22, 26; Gudea 1985, pp. 159-165. *Numerus* fortlets for example ranged between 0.6-1 hectares. However, smaller fortlets are known to have existed too, for example at Degerfeld with 0.09, or at Stockstadt with 0.3 hectares, both on the Germanic *limes*. In this study area, the biggest was Fortlet 4, with 0.7 hectares. Fortlets 2 and 3 were only 0.2-0.23 hectares, whereas Fortlets 5 and 6 were 0.12-0.13 hectares respectively. The smallest one was Fortlet 7, with 0.06 hectares.

74 Hodgson 1993, pp. 343-344, 347; Ferenczi 1959, p. 344. According to Ferenczi, Fortlet 3 might have been something similar.

75 Hodgson 1993, p. 344. Milecastle 48 on Hadrian's Wall near the Poltross Burn for example.

76 Hodgson 1993, p. 346. A detachment of an auxiliary unit from Pfünz serving at Böhming for instance.

Auxiliary fort, but with 2' and 3' visual arcs it fell outside the threshold. Nevertheless, it was always visible from Watchtowers 3a and 4, at fuzzy memberships above 0.5 in every condition. Another smaller camp, Fortlet 5, was positioned between two towers, Watchtowers 10 and 11, at the end of another valley, the Gârbului valley. Fortlet 6 was likewise positioned between two towers. Both Fortlets 5 and 6 were visible from Watchtower 11, at fuzzy memberships above 0.5 in every condition. The only other fortlet visible from any of the watchtowers was Fortlet 2, but only from Watchtower 11. However, considering that it was 15 km away, it was so probably only in special circumstances. Fortlets 4 and 7 were not seen from any position, but 4 might have been visible from Watchtower 9. While Fortlet 4 was located in open field, but near a tiny stream, 7 was at the entrance of the Poic pass. Fortlet 2 was probably close to the Crișul Repede, in similar fashion to Fortlet 3. Unfortunately, the fortlets are the least well known archaeologically. Their chronological sequence is also unclear.

### 3.2. Communication

The architectural defenses of Roman forts and fortlets were relatively modest, as mentioned before. While these were provided with one or several V-shaped surrounding ditches and crenellated walls made of stone or wood and earth<sup>77</sup>, the watchtowers did not appear much stronger. On Trajan's Column, they were not depicted with crenellations at all, but only with a surrounding palisade. Their size indicates that their garrison could not have been very large either<sup>78</sup>, but some structures might have housed more people than others. In case of serious emergency, they probably would have had to rely on fortlets or forts for assistance. The proximity to, but also direct intervisibility with those sites might indicate that. Yet, not every watchtower from this study area had direct contact with, or was very close to these bigger military sites.<sup>79</sup> Nevertheless, the structures complemented each others' views, and were also within sight of one another. Although there is no direct evidence supporting the existence of any signaling in this case, the results indicate that it theoretically might have been possible. The iconographic sources depict torches placed on the observation platforms. Polybios, writing in the second century B.c., described how messages could be transmitted with torches if both parties were familiar with a special code.<sup>80</sup> Vegetius on the other hand, writing in the fourth century, did not mention any similar code, but only the signaling method, which was fire during the night, and smoke during the day.<sup>81</sup>

Whatever was the case, recognition of people standing on watchtowers might have been just as important. However, success would have depended on factors like object-background color, eyesight, weather, time of day, season of year, but also tower spacings. In this study,

77 Hanel 2007, p. 402.

78 Van Dierendock 2004, p. 92. It was estimated by Baatz at 4-5 guards.

79 Hodgson 1993, pp. 344, 348. On the Germanic *limes*, forts and fortlets were more unevenly distributed along the frontier, unlike the milecastles on Hadrian's Wall. In Strecke 13 and 14 for example, some towers were a considerable distance away from such military sites.

80 Polybios, 10.43-47.

81 Vegetius, 3.5.



when viewing human sized targets with 1' visual arc, considering that recognition would have theoretically occurred at fuzzy memberships above 0.5, continuous intervisibility occurred along the entire frontier, except in one place. For many towers, recognition was possible as far as their second neighbors at least, which meant a range of less than 4.5 km, while no immediate neighboring towers fell out of that range. With 2' visual arc simulating less than ideal visibility conditions, intervisibility still occurred in most places, at a maximum range of 2.2 km. With 3' visual arc however, positive results were obtained in fewer places, at a maximum range of 1.5 km. The spacing between towers influenced significantly these results. In this study area, the maximum spacing was 3.3 km, while the lowest 0.43 km.<sup>82</sup> However, the spacings may also be influenced by the number of known towers. Nevertheless, the viewsheds showed that the watchtowers found along the Vărădeștilor valley were placed in such way as to complement each others views. In situations such as these, strategic motives might have determined their spacings. As a consequence, they might have remained intervisible probably even in poorer visibility conditions. However, that means that the more far spaced towers would have faced problems in such situations.

Although recognition of individuals would have been important and probably possible, transmitting signals might have worked differently. Grey smoke rising in the blue sky, bright fires burning in the night, or perhaps even colored flags waving in the air might have been easier to spot. In those cases, if the observer understood the context of their use, detection alone would have sufficed. The maximum threshold for detection acuity is known to be 0.5" visual arc.<sup>83</sup> If a 1 m sized object was considered for example, a theoretical range of 413 km would be obtained for the crossover length. At more modest ranges of 15 km, detection of visual signals very likely might have been possible under very favorable conditions. Based on site spacings, Donaldson initially suggested that the effective range of visual signals used by the Roman army was limited to around one Roman mile (1.5 km). However, experiments showed that even beacon signals had much greater ranges, even in poorer weather.<sup>84</sup> For detecting enemy movements too, context would have played an important role. Large groups of individuals heading towards the border would have easily drawn attention, especially if friendly units were not expected to appear from that direction. The 16 km range binary viewsheds, and especially the cumulative viewshed obtained from those, showed that a continuous field of view existed all along the Drăgan, Crișul Repede and Poic valleys up to 5-6 km west from the line of towers.<sup>85</sup> However, both the observing and visual signaling efficiency very likely would have been downgraded in bad visibility conditions.

It is possible that they employed other means to tackle those problems. The Roman army is known to have used musical instruments (*cornu*, *buccina*, *tuba*). Vegetius for example

---

82 Hodgson 1993, p. 86; Woolliscroft 1993, pp. 293-294. In the Taunus sector on the Germanic *limes*, they were no more than 0.6 km away on average. On the Gask ridge on the other hand, they were between 0.8 and 4.2 km. On the Wetterau, also on the Germanic *limes*, they were similar to the latter, but slightly shorter.

83 Ogburn 2006, p. 406.

84 Woolliscroft 1993, pp. 294-295.

85 Marcu and Cupcea 2013, p. 584. They claimed that the line of Watchtowers could mostly see southwest and northwest, but only to a limited extent towards west. For this reason they argued that the system did not primarily serve a defensive purpose, but was meant for regulating the movement of people and goods. However, their analysis did not take into account Watchtower 12b.

mentioned that trumpets were sounded when mounting or relieving legionary guards, but different instruments were used in different situations.<sup>86</sup> A mouthpiece from an instrument was even discovered in watchtower WP 4/18 on the Germanic *limes*.<sup>87</sup> Acoustic signaling would have provided an alternative, especially to towers that were more isolated from the rest, like Watchtower 1. Acoustic signals coming from closely spaced towers might have been more confusing, unless a certain musical note was used for different towers. Nevertheless, intervisibility might have still occurred in such places, even in less than perfect visibility conditions.

As an alternative to static observations and signaling, a more mobile approach might have also been used in the form of scouting. Although it was not a signaling method in itself, it represented an alternative form of surveillance and transmitting messages. The Roman army made extensive use of scouts from the Republican period onwards. There are multiple references to intelligence gathering in historical sources.<sup>88</sup> There were even special groups of soldiers attested in inscriptions as *exploratores*.<sup>89</sup> They would have usually used mounts for fast travelling, except in very mountainous areas.<sup>90</sup>

### 3.3. The local garrison

At the auxiliary fort near Bologa, three auxiliary units have been attested in inscriptions. *Cohors I Ulpia Brittonum milliaria* occupied the first phase of the fort. Later, when the military site was expanded, it was replaced with *Cohors II Hispanorum equitata* and *Cohors I Aelia Gaesatorum milliaria*.<sup>91</sup> While *Cohors II Hispanorum* surely had mounted soldiers, for *Cohors I Ulpia Brittonum milliaria*, it is more uncertain.<sup>92</sup> The former unit would have possessed a theoretical number of 120 horsemen, while the latter 240, some of which might have been used for scouting duties too. The rest of the troops would have been made up of infantry, where the *milliaria* cohorts would have numbered around 800, whereas *Cohors II Hispanorum* 480.<sup>93</sup> Although the Auxiliary fort would have been considered their formal base, some soldiers serving in those units very likely would have been assigned tasks that required their presence elsewhere.<sup>94</sup> The construction and maintenance of frontier installations would have been one of their duties. In this study area, at Watchtower 10, a tile fragment bearing the

---

86 Vegetius, 2.15.

87 Hodgson 1993, p. 171; Marcu and Cupcea 2015, p. 72.

88 Vegetius, 3.5; Josephus, 3.6.2.

89 CIL III 3648, 8074.29a, 11918. A *centuria exploratorum* on a votive altar from Visegrád, Pannonia Superior. *Numerus Exploratorum Germanicorum* on stamped tiles from Orăștioara de Sus, Dacia. *Cohors IX Batavorum equitata milliaria exploratorum* in another votive inscription from Weissenburg in Bayern, Raetia.

90 Goldsworthy 1996, p. 125.

91 Gudea 1997, pp. 18, 24.

92 CIL III 843; 10331. For the former unit, a *decurio* appears on a funerary monument from Bologa. For the latter, an *equus* is present in a fragmentary inscription from Adony, Pannonia Inferior, yet it could belong to a different unit with a similar name, *Cohors I Britannica milliaria*, also attested in that province at that time.

93 Goldsworthy 1996, p. 22.

94 Goldsworthy 2003, pp. 144-145. A good example represents the surviving strength reports of auxiliary units from Britannia and Moesia, discovered at Vindolanda and Egypt.



same type of *Coh. II HISP.* stamp was found as the ones from the Auxiliary fort.<sup>95</sup> If some of the frontier installations were built by the auxiliary units from the nearby fort, then very likely they would have been responsible for garrisoning them too.<sup>96</sup> However, it is unclear how many of them were needed to operate these installations because their chronological sequence is uncertain, as well as the exact numbers necessary for each. Nevertheless, it is not unlikely that the local defensive system was developed gradually. Perhaps the expansion of the Auxiliary fort's garrison might have had something to do with that.

### 3.4. The defences of Roman Dacia

The military installations near Bologna belonged to the Dacian *limes*, representing the frontier of the Roman province of Dacia. The line of watchtowers and other installations continued north of this study area, across the Poic valley, but there are no known similar sites to the south. In Dacia (Figure 68), like elsewhere, due to topographic reasons, the defensive system was neither uniform nor ubiquitous. In the central-northeastern parts, in nowadays eastern Transylvania, more certainly from Hadrian's reign onwards, the military installations were predominantly concentrated in front of valleys and mountain passes.<sup>97</sup> In the southeastern parts, between southern Transylvania and north of the Danube, a more continuous type of frontier existed on the other hand, the "*Limes Alutanus*" dating from Trajan's Dacian wars, while the "*Limes Transalutanus*" being a later creation east of the previous one.<sup>98</sup> The southwestern frontier defences, established during Trajan's reign, were of a similar type, but were apparently withdrawn somewhat to the east, and rearranged during Hadrian's reign.<sup>99</sup> Sections of a same type of possible Trajanic defensive system were discovered in the northwestern parts as well, running some 40-60 km west of the current study area.<sup>100</sup> In that case, the section of the *limes* studied in this thesis might have been developed somewhat later, perhaps after the abandonment of the previous line of defence. Soon after the defeat of the Iazyges during Hadrian's early rule for example, administrative and military changes occurred in Dacia, when the province was subdivided into Dacia Porolissensis (north), Dacia Superior (center-west) and Dacia Inferior (southeast). As a result, the Roman armies of Dacia were able to cooperate more easily with troops from neighboring provinces in future conflicts appearing on multiple fronts.<sup>101</sup>

---

95 Gudea 1985, p. 164.

96 CIL III 13795. An example from Dacia Inferior was *Numerus Burgariorum et Veredariorum*.

97 Pánczél et al. 2011, pp. 173-180; Karavas 2001, pp. 216-219.

98 Karavas 2001, pp. 219-226. Petolescu 2002, pp. 25-26, 55-58. The dating of the latter *limes* was heavily debated. It was either a Hadrianic creation, or a Severan one. However, most of the area north of the Danube was attached to Moesia Inferior during the Dacian wars. It was part of Dacia only from Hadrian's reign onwards.

99 Nemeth 2005, pp. 35-50.

100 Matei and Gindele 2006, pp. 181-201. Something similar was found in modern-day Hungary as well, and the two sections heading towards each other might belong to the same establishment. This *limes* would have secured the road running between northern Dacia and Pannonia.

101 Petolescu 2002, pp. 25-28. During Trajan's reign, Dacia was administered by a senatorial governor of consular rank. After the administrative division, Dacia Superior was assigned a senatorial governor of



Figure 68. The military camps of the Roman province of Dacia and the frontiers (Literature: Bărbulescu 2005, p. 60. Resources and tools: GIMP; Google Earth 2015.3).

This entire frontier was also a continuous type of fortified border, being reminiscent of the Upper Germanic *limes* and the ones found in Britannia. Although, small variations always existed in terms of spacing and density of sites, all of these defensive systems possessed a cordon of watchtowers reinforced with fortlets and linear defensive walls. In this case however, the only missing component was the continuous walls, which were probably substituted by the rough terrain in most places. The cordon of watchtowers was an indicator of how important it was for the Romans to have a continuous field of view over the entire length of the frontier, including over the areas lying in front of the defences.<sup>102</sup> In the area studied in this paper, the results showed just that. Although in some places there was narrower spacing between towers, their density was more likely related to topographic variations. That was indicated by how they complemented each others' views over the surrounding area. In rough terrain, that would have been unattainable with fewer installations. Overall, ground surveillance and lateral communication was the main purpose of these watchtowers. The continuous field of view they offered would have prevented intruders from entering the field of view anywhere or passing between the sites unnoticed. The spacing, although varied, would have still permitted, even in places where it was wider, to make visual contact with the neighboring towers, at least in good visibility conditions, to communicate suspicious movements. In some places, the approaching individuals would have been spotted faster than at others, that also depending on visibility conditions. Nevertheless, lateral signaling would have still permitted the soldiers to pass warning signals to the neighboring military

praetorian rank, while the other two provinces were administered by equestrian governors.

<sup>102</sup> Hodgson 1993, pp. 85-87, 374, 381-389. On riverine frontiers, that was partly achieved with the Roman riverine fleets, reason why there probably never was a cordon of towers there, especially during the first and second centuries, but only individual ones.



installations. Even if the infiltrators would had managed to pass through the sites with or without violence, news of their breakthrough should have reached the fortlets or the auxiliary forts relatively fast. There, the detachments tasked with rearward garrisoning would have left their military camps to intercept the intruders. Moreover, the troops in Dacia were arranged in such way as to deal with multiple levels of threats. On the edge of the province were usually garrisoned in linear fashion the smaller auxiliary infantry units for the most part (Bologa, Buciumi, Porolissum, Micia among many others), in the interior were positioned the more powerful but far fewer legions (Apulum, and later Potaissa too), while the intermediary areas were occupied by fast moving auxiliary cavalry units (Gilău, Gherla, Războieni to name but a few).<sup>103</sup>

### 3.5. Final remarks

The entire defensive system was meant to provide the Roman army the necessary support in preserving the political, economical and social stability of the rear areas. In Europe, the very dispositions of the units seem to indicate that, considering that most troops were kept on the peripheral provinces of the Empire. While during the first century, the units were arranged in-depth (Gask ridge, early Upper Germanic *limes*), indicating a more flexible approach towards external security, in the second century, a more defensive linear type of defence was favored instead. In the latter case, the units were spread as thinly but as safely as possible, which means that the Romans were concerned with securing the entire length of the border zone. This type of arrangement probably occurred as a result of change of external policy or increasing threats. However, the change did not occur suddenly and simultaneously in every province or every part of the same province, which indicates that local specific problems dictated corresponding solutions. On the Eastern frontier on the other hand, especially in Arabia and Syria, the linear approach was not enforced because it was neither possible nor necessary due to climatic reasons. While the land boundaries provided with cordons of watchtowers served its purpose for a certain amount of time, in Dacia, like in other parts, it was eventually abandoned in the third century in favour of the riverine frontiers.<sup>104</sup>

---

103 Ferenczi 1968, pp. 93-94; Gudea, 1985, pp. 143-144; Karavas 2001, pp. 198-226.

104 Cupcea 2015, pp. 15-17; Hodgson 1993, pp. 85-90, 308-309, 390-396.

#### 4. Conclusion

The results obtained in this thesis revealed a few interesting points. In the previous viewshed study conducted in the same area, longer ranges were used for assessing visibility and intervisibility. The observer heights used for the watchtowers were also higher in most cases. Despite all that, only minor differences were reported in terms of intervisibility, which would not have significantly affected the system. Although it was already noticed that the towers complemented each other's views, it was argued that only the southwestern and northwestern parts were clearly visible, whereas the western areas, from where the enemy would have most likely approached, could only be seen to a limited extent. Therefore, it was believed that the system did not serve a strictly defensive purpose, but it was more meant for regulating trade and movements of people. However, Watchtower 12b was not analyzed in the previous study.

In my study, its inclusion and analysis altered the overall results a bit. The cumulative viewsheds for example showed that there was a continuous field of view stretching from southwest to northwest 5-6 km west of the line of towers. This indicates that movements occurring anywhere along the frontier could have been spotted from a considerable distance. However, the field of view lying in front of the towers was narrower in some parts, and between the towers it was interrupted in one place. It is likely that the interruption was caused by gaps in the archaeological knowledge because intervisibility between neighboring towers did not occur only in that area (Watchtower 11 - Watchtower 12b). Nevertheless, the continuous field of view lying in front of the line of towers still hypothetically ensured that intruders could not have traversed it, passed between the military installations and encircled the outposts without any warning.

Moreover, my contribution in the form of fuzzy viewsheds showed that different visibility conditions might have affected the functioning of the system. With 1' visual arc, which is the standard recognition limit of normal 20/20 vision under very good conditions, intervisibility between neighboring towers occurred at higher fuzzy memberships (above 0.5) everywhere along this section of the frontier, except in the area mentioned above. Where the site spacings were narrower, the guards standing on watchtowers could have recognized relatively well their comrades from even the second or third neighboring towers. In such examples, intervisibility was more likely shaped by the need to complement the views from different positions. With 2' and 3' visual arcs simulating worse visual conditions, intervisibility more often occurred at lower fuzzy memberships (below 0.5) where the site spacings were considerably wider. Although the closely spaced watchtowers could have still maintained contact at higher fuzzy memberships, for the more widely spaced ones it would have been different. All of these indicate that the military installations were carefully placed in relation to one another, and their purpose probably was ground surveillance and lateral communication. However, in less than optimum conditions, some of the more isolated outposts might have become more vulnerable. This could suggest that visual signaling and static observations alone might have not always sufficed. Nevertheless, the findings seem to point towards a typical defensive system.



Lastly, the results should be taken with a bit of caution I might say. The dataset used in this study was not of top quality. In the absence of a higher resolution and more accurate dataset for this study area, assessing the sensitivity of the results obtained from this one should represent the next step. Probable viewsheds could estimate to what extent was visibility and intervisibility influenced by horizontal and vertical errors. However, despite the concerns for accuracy, the obtained results would always point only towards a theoretical model. The signaling arrangements of the sites and their possible heights can only reveal how the defensive system might have functioned in different situations, as well as the possible role of individual outposts within the system. With no direct physical traces left, that is all researchers can hope for.

#### 4.1. Acknowledgements

First of all, I would like to thank my primary and secondary supervisors Henrik Gerding and Nicolò Dell'Unto. Their numerous feedback and encouragements proved highly valuable throughout the entire process. Almost as important was the influence of my former and current teachers who had taught and introduced me to Classical and Digital archeology during my studies. Without their guidance, I would not have acquired interest and knowledge in these fields. Last but not the least, I wish to thank my family for encouraging and supporting me in pursuing what I enjoy.

## 5. References

### 5.1. Literature

- Bărbulescu 2005 Bărbulescu, M., *Atlas-dicționar al Daciei romane*, Cluj-Napoca, Tribuna, 2005.
- Bell 1998 Bell, T., 'A Roman Signal Station at Whitby', *Archaeological Journal*, vol. 155, no. 1, pp. 303-322.
- Bell 1999 Bell, T., 'Reconstructing Archaeology from the Landscape: GIS, CAD and The Roman Signal Station at Whitby', Dingwall, L., S. Exon, V. Gaffney, S. Laflin and M. van Leusen (eds.), *CAA97. Computer Applications and Quantitative Methods in Archaeology 1997*, Oxford, Archaeopress, 1999, pp. 14-18.
- Buday 1912 Buday, Á., 'Vannak-e limes maradványok a Meszesen?', *Dolgozatok az Erdélyi Nemzeti Múzeum Érem- és Régiségtárából*, vol. 3, no. 1, 1912, pp. 99-119.
- Butler 1983 Butler, R. M., 'The construction of urban defences', in Maloney, J. and B. Hobley (eds.), *Roman Urban Defences in the West*, The Council for British Archaeology, 1983, pp. 125-130.
- Chapman 2006 Chapman, H., *Landscape archaeology and GIS*, The History Press, 2006.
- CIL III 1902 Mommsen, T., Hirschfeld, O., Domaszewski, Alfred von (eds.), *Corpus Inscriptionum Latinarum. Inscriptionum Orientis et Illyrici latinarum supplementum*, vol. III, no. 1, 1902, Berlin.
- Conolly and Lake 2006 Conolly, J., Lake, M., *Geographical Information Systems in Archaeology*, New York, Cambridge University Press, 2006.
- Cupcea 2015 Cupcea, G., 'The evolution of Roman frontier concept and policy', *Journal of Ancient History and Archaeology*, no. 2.1, 2015, pp. 12-22.
- Daicoviciu 1936 Daicoviciu, C., 'Dacica. În jurul unor probleme din Dacia romană', *Anuarul Institutului de Studii Clasice*, vol. 2 (1933-1935), 1936, pp. 240-256.



- Driessen and Abudana 2013      Driessen, M. and Abudana, F., 'The Udhruh lines of sight: connectivity in the hinterland of Petra', *Tijdschrift voor Mediterrane Archeologie*, vol. 25, no. 50, 2015, pp. 45-52.
- Ferenczi 1959      Ferenczi, I., 'Contribuții cu privire la problema limesului de vest al Daciei. I', *Studii și Cercetări de Istorie Veche*, vol. 10, no. 2, 1959, pp. 337-354.
- Ferenczi 1968      Ferenczi, I., 'Observații cu privire la sistemul și caracterul așa-zisului *limes Dacicus*', *Acta Musei Napocensis*, vol. 5, 1968, pp.75-98.
- Finály 1864      Finály, H., 'Római nyomok Erdély északnyugati részén', *Az Erdélyi Múzeum-Egyesület Évkönyve*, vol. 3, no. 1, 1864, pp. 5-9.
- Forkuor and Maathuis 2012      Forkuor, G. and B. Maathuis, 'Comparison of SRTM and ASTER derived digital elevation models over two regions in Ghana - implications for hydrological and environmental modeling', in T. Piacentini (ed.), *Studies on Environmental and Applied Geomorphology*, InTech, 2012, pp. 219-240.
- Fisher 1995      Fisher, P. F., 'An exploration of probable viewsheds in landscape planning', *Environment and Planning B: Planning and Design*, vol. 22, 1995, pp. 527-546.
- Fisher 1999      Fisher, P. F., 'Models of uncertainty in spatial data', *Geographical Information Systems*, vol. 1, 1999, pp. 191-205.
- Gerding 2013      Gerding, H., 'Roofs and superstructures', in Blackman, D., Rankov, B., Baika, K., Gerding, H., J. Pakkanen (eds.), *Shipheds of the Mediterranean*, New York, Cambridge University Press, 2013, pp. 141-184.
- Goldsworthy 1996      Goldsworthy, A. K., *The Roman Army at War 100 B.C. - A.D. 200*, Oxford, Clarendon Press, 1996.
- Goldsworthy 2003      Goldsworthy, A. K., *The Complete Roman Army*, New York, Thames and Hudson, 2003.
- Gudea 1971      Gudea, N., 'Limesul roman în zona castrului de la Bologa', *Acta Musei Napocensis*, vol. 8, 1971, pp. 507-530.
- Gudea 1979      Gudea, N., 'The defensive system of Roman Dacia', *Britannia*, vol. 10, 1979, pp. 63-87.

- Gudea 1985 Gudea, N., 'Contribuții la istoria militară a Daciei Porolissensis. 1. Linia înaintată de fortificații mici de pe sectorul de NV al limesului provinciei între caestrele de la Bologa și Tihău', *Acta Musei Porolissensis*, vol. 9, 1985, pp. 143-218.
- Gudea 1997 Gudea, N., *Das Römergrenzkastell von Bologa - Resculum / Castrul roman de la Bologa - Resculum*, Zalău, Muzeul Județean de Istorie și Artă, 1997.
- Guth 2010 Guth, P. L., 'Geomorphometric comparison of ASTER DEM and SRTM', *ASPRS/CaGIS*, Orlando, Florida, November 15-19, 2010, pp. 15-19.
- Hanel 2007 Hanel, N., 'Military Camps, *Canabae*, and *Vici*. The Archaeological Evidence', in Erdkamp, P. (ed.), *A Companion to the Roman Army*, Blackwell Publishing, 2007, pp. 395-416.
- Hodgson 1993 Hodgson, N. R., 'The Military Limes - Aspects of the Comparative Development, Function and Significance of the Linear Frontier Systems of the Roman Empire up to A.D. 200', PhD Thesis, University of Newcastle Upon Tyne, 1993.
- ILS 1892 Dessau, H., *Inscriptiones Latinae Selectae*, vol. I, III, 1892, Berlin.
- Isaac 1988 Isaac, B., 'The meaning of the terms limes and limitanei', *The Journal of Roman Studies*, vol. 78, 1988, pp. 125-147.
- Josephus Josephus, *The Jewish War*, transl. Rev. Traill, R., Houlston and Atoneman, London, 1851.
- Karavas 2001 Karavas, J., 'The evolution of Roman frontier defence systems and fortifications in the lower Danube provinces in the first and second centuries A.D.', PhD Thesis, Durham University, 2001.
- Kvamme 1999 Kvamme, K. L., 'Recent directions and developments in Geographical Information Systems', *Journal of Archaeological Research*, vol. 7, no. 2, 1999, pp. 155-201.
- Lake and Woodman 2003 Lake, M. W. and Woodman, P. E., 'Visibility studies in archaeology: a review and case study', *Environment and Planning B: Planning and Design*, vol. 30, 2003, pp. 689-707.



- Linge 2012 Linge, H., *Infotafel am Wachturm Wp 10/9 des Odenwaldlimes*, 2012, [https://de.wikipedia.org/wiki/Datei:201206161804b\\_Wp\\_10-9\\_Infotafel.jpg](https://de.wikipedia.org/wiki/Datei:201206161804b_Wp_10-9_Infotafel.jpg), (accessed 6 May 2017).
- Lock 1995 Lock, G., 'Archaeological computing, archaeological theory and moves towards contextualism', in Huggett, J. and N. Ryan (eds.), *CAA94. Computer applications and quantitative methods in archaeology 1994*, Oxford, Tempus Reparatum, 1995, pp. 13-18.
- Lock 2001 Lock, G., 'Theorizing the practice or practicing the theory: archaeology and GIS', *Archaeologia Polona*, vol. 39, 2001, pp. 153-164.
- Marcu and Cupcea 2013 Marcu, F. and G. Cupcea, 'Topografia limes-ului de nord-vest al Daciei în zona castrului de la Bologna', in A. Stavilă et al. (eds.), *ArheoVest, I: In memoriam Liviu Măruia, Interdisciplinaritate în Arheologie și Istorie, Timișoara 7 decembrie 2013*, Szeged, JATEpress Kiadó, 2013, pp. 569-589.
- Marcu and Cupcea 2015 Marcu, F. and G. Cupcea, 'Recent developments in the fort of Bologna and on the northwestern Dacian limes', *Dacia. Revue d'Archéologie et d'Histoire Ancienne. Nouvelle Série*, vol. 59, 2015, pp. 67-82.
- Marcu 2006 Marcu, F., 'Organizarea internă a castrelor din Dacia în timpul lui Traian', in E. S. Teodor and Țentea, O. (eds.), *Dacia Augusti Provincia. Crearea Provinciei*, București, Editura Cetatea de Scaun, 2006, pp. 153-164.
- Matei and Gindele 2006 Matei, A. V., Gindele, R., 'Sistemul defensiv roman din nord-vestul Daciei descoperit prin cercetările arheologice de la Supurul de Sus (jud. Satu Mare) și pe baza documentației din izvoarele scrise', in E. S. Teodor and Țentea, O. (eds.), *Dacia Augusti Provincia. Crearea Provinciei*, București, Editura Cetatea de Scaun, 2006, pp. 181-206.
- Nemeth 2005 Nemeth, E., *Armata în Sud-Vestul Daciei Romane*, Timișoara, Editura Mirton, 2005.
- Ogburn 2006 Ogburn, D. E., 'Assessing the level of visibility of cultural objects in past landscapes', *Journal of Archaeological Science*, vol. 33, 2006, pp. 405-413.

- Oltean 2007 Oltean, I., A., *Dacia. Landscape, colonisation and romanisation*, New York, Routledge, 2007.
- Pánczél et al. 2011 Pánczél, Sz. P., Szabó, M., Visy, Zs., 'Archaeological research on the eastern frontier of Dacia Superior, *The Danube Limes Project Archaeological Research Between 2008-2011*, Pécs, University of Pécs, 2011, pp. 173-196.
- Petolescu 2002 Petolescu, C. C., *Auxilia Daciae*, București, Ars Docendi, 2002.
- Polybios Polybios, *The Histories*, transl. Shuckburgh, E. S., Macmillan and Co, 1889.
- Radnóti 1944-45 Rádnóti, A., 'A dáciai limes a Meszesen', *Archaeologiai Értesítő*, vol. 5-6, no. 3, 1944-1945, pp. 137-168.
- Roth 1999 Roth, J. P., *The Logistics of the Roman Army at War (264 B.C. - A.D. 235)*, Leiden-Boston-Köln, Brill, 1998.
- Suwandana et al. 2012 Suwandana, E. et al., 'Evaluation of ASTER GDEM2 in comparison with GDEM1, SRTM DEM and topographic-map-derived DEM using inundation area analysis and RTK-dGPS data', *Remote Sensing*, 4, 2012, pp. 2419-2431.
- Te Vehne 2004 Te Vehne, C., *Der römische Limes in Baden-Württemberg*, 2004,  
<http://www.limesseiten.de/LIMES/TUERME.HTML>,  
(accessed 6 April 2017).
- Téglás 1907 Téglás, G., 'A limes Dacicus igazolása. (a gerebenhegyi szakasz Kissebestől a Pojk-szorosig.)', *Akadémiai Értesítő*, vol. 18, no. 205-216, 1907, pp. 565-580.
- Teodor 2015 Teodor, E. S., *The Invisible Giant: Limes Transalutanus. An overview south of Argeș River*, Târgoviște, Editura Cetatea de Scaun, 2015.
- The Build. Reg. 2010 The Building Regulations 2010 (Approved Document A1/2) s2C6 and 2C7.
- Torma 1880 Torma, K., *A limes Dacicus felső része*, Budapest, M. Tud. Akadémia, 1880.



- Van Dierendonck 2004 Van Dierendonck, R., 'Five postholes and a ditch: the Valkenburg-Marktvelde timber watch and signal tower', in Vermeulen F., Sas K., W. Dhaeze (eds.), *Archaeology in confrontation. Aspects of Roman military presence in the northwest*, Archaeological Reports Ghent University 2, 2004, pp. 73-102.
- Van Leusen 1999 Van Leusen, M., 'Viewshed and Cost Surface Analysis Using GIS (Cartographic Modelling in a Cell-Based GIS II)', in Barceló, J. A., I. Briz and A. Vila (eds.), *New Techniques for Old Times - CAA98*, Proceedings of the 26th Conference, BAR International Series 757, Oxford, Archaeopress, 1999, pp. 215-224.
- Vegetius Vegetius, *Epitoma Rei Militaris*, transl. Clarke, J., London, 1767.
- Vitruvius Vitruvius, *De Architectura*, transl. Morgan, M. H., Warren, H. L., Harvard University Press, 1914.
- Wheatley and Gillings 2000 Wheatley, D.W., Gillings, M., 'Vision perception and GIS: some notes on the development of enriched approaches to the study of archaeological visibility', in Lock, G. (ed.), *Beyond the map: Archaeology and Spatial Technologies*, Amsterdam, IOS Press, 2000, pp. 1-29.
- Woolliscroft 1993 Woolliscroft, D. J., '*Signalling and the design of the Gask Ridge system*', Proceedings of the Society of Antiquaries of Scotland, vol. 123, 1993, pp. 291-313.
- Zitterkopf and Sidebotham 1989 Zitterkopf, R. E. and Sidebotham, S. E., 'Stations and Towers on the Quseir-Nile Road', *The Journal of Egyptian Archaeology*, vol. 75, 1989, pp. 155-189.

## 5.2. Resources and tools

- ASTER Global DEM - 30 m NASA JPL, *ASTER Global Digital Elevation Model version 002*, NASA JPL, 2009, <https://doi.org/10.5067/ASTER/ASTGTM.002>, (accessed 19 February 2017).
- Blender Blender 2.74 Development Team, *Blender 3D Computer Graphics Software*, Open Source Project, 2015, <https://www.blender.org/>, (accessed 5 April 2017).

- GIMP GIMP 2.8.6 Development Team, *GNU Image Manipulator Program*, Open Source Project, 2013, <http://gimp.org>, (accessed 3 February 2017).
- Google Earth 2009.1 Google Earth Pro 7.1.7.2606 Development Team, *Fortlet 2* 46.953591° N. 22.766473° E. eye altitude 804 m, 19 June 2009, DigitalGlobe 2016, <https://www.google.com/earth/index.html>, (accessed 22 February 2017).
- Google Earth 2009.2 Google Earth Pro 7.1.7.2606 Development Team, *Fortlet 3* 46.911829° N. 22.865244° E. eye altitude 1.08 km, 19 June 2009, DigitalGlobe 2016, <https://www.google.com/earth/index.html>, (accessed 22 February 2017).
- Google Earth 2009.3 Google Earth Pro 7.1.7.2606 Development Team, *Fortlet 5* 46.941552° N. 22.900349° E. eye altitude 1.33 km, 19 June 2009, DigitalGlobe 2016, <https://www.google.com/earth/index.html>, (accessed 22 February 2017).
- Google Earth 2009.4 Google Earth Pro 7.1.7.2606 Development Team, *Fortlet 6* 46.955043° N. 22.897391° E. eye altitude 1.27 km, 19 June 2009, DigitalGlobe 2016, <https://www.google.com/earth/index.html>, (accessed 22 February 2017).
- Google Earth 2009.5 Google Earth Pro 7.1.7.2606 Development Team, *Fortlet 7* 46.986384° N. 22.914593° E. eye altitude 988 m, 19 June 2009, DigitalGlobe 2016, <https://www.google.com/earth/index.html>, (accessed 22 February 2017).
- Google Earth 2009.6 Google Earth Pro 7.1.7.2606 Development Team, *Fortlet 7 different angle* 46.986563° N. 22.914043° E. eye altitude 617 m, 19 June 2009, DigitalGlobe 2016, <https://www.google.com/earth/index.html>, (accessed 22 February 2017).

- Google Earth 2009.7 Google Earth Pro 7.1.7.2606 Development Team, *Linear defenses 2* 46.910876° N. 22.869378° E. eye altitude 1.48 km, 19 June 2009, DigitalGlobe 2016, <https://www.google.com/earth/index.html>, (accessed 22 February 2017).
- Google Earth 2009.8 Google Earth Pro 7.1.7.2606 Development Team, *Linear defenses 3* 46.911523° N. 22.879634° E. eye altitude 2.01 km, 19 June 2009, DigitalGlobe 2016, <https://www.google.com/earth/index.html>, (accessed 22 February 2017).
- Google Earth 2009.9 Google Earth Pro 7.1.7.2606 Development Team, *Linear defenses 4* 46.915052° N. 22.884022° E. eye altitude 1.87 km, 19 June 2009, DigitalGlobe 2016, <https://www.google.com/earth/index.html>, (accessed 22 February 2017).
- Google Earth 2009.10 Google Earth Pro 7.1.7.2606 Development Team, *Linear defenses 5* 46.975443° N. 22.900624° E. eye altitude 1.44 km, 19 June 2009, DigitalGlobe 2016, <https://www.google.com/earth/index.html>, (accessed 22 February 2017).
- Google Earth 2009.11 Google Earth Pro 7.1.7.2606 Development Team, *Watchtower 1* 46.884269° N. 22.858284° E. eye altitude 1.15 km, 19 June 2009, DigitalGlobe 2016, <https://www.google.com/earth/index.html>, (accessed 23 February 2017).
- Google Earth 2009.12 Google Earth Pro 7.1.7.2606 Development Team, *Watchtowers 3* 46.911339° N. 22.869180° E. eye altitude 774 m, 19 June 2009, DigitalGlobe 2016, <https://www.google.com/earth/index.html>, (accessed 23 February 2017).
- Google Earth 2009.13 Google Earth Pro 7.1.7.2606 Development Team, *Watchtower 4* 46.910302° N. 22.872899° E. eye altitude 789 m, 19 June 2009, DigitalGlobe 2016, <https://www.google.com/earth/index.html>, (accessed 23 February 2017).



- Google Earth 2009.14 Google Earth Pro 7.1.7.2606 Development Team, *Watchtower 9* 46.928487° N. 22.904506° E. eye altitude 1.69 km, 19 June 2009, DigitalGlobe 2016, <https://www.google.com/earth/index.html>, (accessed 23 February 2017).
- Google Earth 2009.15 Google Earth Pro 7.1.7.2606 Development Team, *Watchtowers 12* 46.967528° N. 22.898835° E. eye altitude 1.96 km, 19 June 2009, DigitalGlobe 2016, <https://www.google.com/earth/index.html>, (accessed 23 February 2017).
- Google Earth 2009.16 Google Earth Pro 7.1.7.2606 Development Team, *Watchtower 13* 46.981397° N. 22.902598° E. eye altitude 2.98 km, 19 June 2009, DigitalGlobe 2016, <https://www.google.com/earth/index.html>, (accessed 23 February 2017).
- Google Earth 2011.1 Google Earth Pro 7.1.7.2606 Development Team, *Auxiliary fort* 46.885594° N. 22.884639° E. eye altitude 1.6 km, 21 September 2011, DigitalGlobe 2016, <https://www.google.com/earth/index.html>, (accessed 2 February 2017).
- Google Earth 2011.2 Google Earth Pro 7.1.7.2606 Development Team, *Fortlet 1* 46.882638° N. 22.855693° E. eye altitude 1.25 km, 21 September 2011, DigitalGlobe 2016, <https://www.google.com/earth/index.html>, (accessed 22 February 2017).
- Google Earth 2011.3 Google Earth Pro 7.1.7.2606 Development Team, *Fortlet 4* 46.899896° N. 22.923629° E. eye altitude 937 m, 21 September 2011, DigitalGlobe 2016, <https://www.google.com/earth/index.html>, (accessed 22 February 2017).
- Google Earth 2011.4 Google Earth Pro 7.1.7.2606 Development Team, *Linear defenses 1* 46.884026° N. 22.861475° E. eye altitude 3.11 km, 21 September 2011, DigitalGlobe 2016, <https://www.google.com/earth/index.html>, (accessed 22 February 2017).

- Google Earth 2011.5 Google Earth Pro 7.1.7.2606 Development Team, *Watchtower 2* 46.901550° N. 22.847754° E. eye altitude 1.44 km, 21 September 2011, DigitalGlobe 2016, <https://www.google.com/earth/index.html>, (accessed 23 February 2017).
- Google Earth 2011.6 Google Earth Pro 7.1.7.2606 Development Team, *Watchtower 5* 46.914077° N. 22.876629° E. eye altitude 1.02 km, 21 September 2011, DigitalGlobe 2016, <https://www.google.com/earth/index.html>, (accessed 23 February 2017).
- Google Earth 2011.7 Google Earth Pro 7.1.7.2606 Development Team, *Watchtower 6* 46.915859° N. 22.882062° E. eye altitude 1.04 km, 21 September 2011, DigitalGlobe 2016, <https://www.google.com/earth/index.html>, (accessed 23 February 2017).
- Google Earth 2011.8 Google Earth Pro 7.1.7.2606 Development Team, *Watchtower 7* 46.921556° N. 22.887051° E. eye altitude 1.01 km, 21 September 2011, DigitalGlobe 2016, <https://www.google.com/earth/index.html>, (accessed 23 February 2017).
- Google Earth 2011.9 Google Earth Pro 7.1.7.2606 Development Team, *Watchtower 8* 46.926691° N. 22.889771° E. eye altitude 1.21 km, 21 September 2011, DigitalGlobe 2016, <https://www.google.com/earth/index.html>, (accessed 23 February 2017).
- Google Earth 2011.10 Google Earth Pro 7.1.7.2606 Development Team, *Watchtower 10* 46.937199° N. 22.900598° E. eye altitude 1.55 km, 21 September 2011, DigitalGlobe 2016, <https://www.google.com/earth/index.html>, (accessed 23 February 2017).
- Google Earth 2011.11 Google Earth Pro 7.1.7.2606 Development Team, *Watchtower 11* 46.944949° N. 22.898797° E. eye altitude 1.77 km, 21 September 2011, DigitalGlobe 2016, <https://www.google.com/earth/index.html>, (accessed 23 February 2017).

- Google Earth 2015.1 Google Earth Pro 7.1.7.2606 Development Team, *Romania 45.717669° N. 24.585118° E. eye altitude 989.59 km*, 14 December 2015, Image Landsat/Copernicus 2016, <https://www.google.com/earth/index.html>, (accessed 19 February 2017).
- Google Earth 2015.2 Google Earth Pro 7.1.7.2606 Development Team, *Meseş area 47.053534° N. 23.332206° E. eye altitude 102.18 km*, 14 December 2015, Image Landsat/Copernicus 2016, <https://www.google.com/earth/index.html>, (accessed 19 February 2017).
- Google Earth 2015.3 Google Earth Pro 7.1.7.2606 Development Team, *Roman Dacia 45.557147° N. 24.244163° E. eye altitude 661.56 km*, 14 December 2015, Image Landsat/Copernicus 2016, <https://www.google.com/earth/index.html>, (accessed 8 May 2017).
- GRASS GRASS 7.2.0 Development Team, *GRASS Geographic Information System*, Open Source Geospatial Foundation, 2017, <https://grass.osgeo.org/>, (accessed 5 April 2017).
- GPS Coordinates Finder GPS Coordinates Finder 1.3.1 Development team, *GPS Coordinates Finder*, Android Application, 2008-2017, <http://www.ezgu.com/gps-coordinates-finder?i=1>, (accessed 23 February 2017).
- Marcus Aurelius' Column photo Barosaurus Lentus, *Detail from the Column of Marcus Aurelius in Rome*, 2009, [https://sv.wikipedia.org/wiki/Marcus\\_Aurelius-kolonnen#/media/File:Column\\_of\\_Marcus\\_Aurelius\\_-\\_detail3.jpg](https://sv.wikipedia.org/wiki/Marcus_Aurelius-kolonnen#/media/File:Column_of_Marcus_Aurelius_-_detail3.jpg), (accessed 6 April 2017).
- QGIS QGIS 2.14.0-Essen Development Team, *QGIS Geographic Information System*, Open Source Project, 2016, <http://www.qgis.org>, (accessed 3 February 2017).
- Romanian Topographic Maps 1: 20 000 Alexandrov, P. et al., *Planurile directe de tragere 1: 20 000 proiectate în Stereo 70*, 2011, <http://www.geo-spatial.org/download/planurile-directe-de-tragere>, (accessed 23 February 2017).



Soviet Topographic Maps 1: 50 000	Androo-Gherghelaş, P. et al., <i>Hărțile sovietice 1: 50 000 reproiectate în Stereo 70</i> , 2012, <a href="http://www.geospatial.org/download/hartile-sovietice-50k">http://www.geospatial.org/download/hartile-sovietice-50k</a> , (accessed 2 February 2017).
SRTM Global DEM - 30 m	U.S. Geological Survey, <i>SRTM Global Digital Elevation Model version 003</i> , U.S.G.S. and L.P. D.A.A.C., 2015, <a href="https://lta.cr.usgs.gov/SRTM1Arc">https://lta.cr.usgs.gov/SRTM1Arc</a> , (accessed 4 April 2017).
SRTM Global DEM - 90 m	Jarvis, A. et al., <i>Hole-filled SRTM for the globe version 4.1</i> , CGIAR-CSI SRTM 90m Database, 2008, <a href="http://www.cgiar-csi.org/data/srtm-90m-digital-elevation-database-v4-1">http://www.cgiar-csi.org/data/srtm-90m-digital-elevation-database-v4-1</a> , (accessed 22 February 2017).
Trajan's Column photo A	Cichorius, C., <i>Die Reliefs der Traianssäule</i> , Tafel IV, Verlag von Georg Reimer, Berlin, 1896, <a href="https://commons.wikimedia.org/wiki/Trajan%27s_Column_-_Cichorius_Plates#/media/File:004_Conrad_Cichorius,_Die_Reliefs_der_Traians%C3%A4ule,_Tafel_IV_(Ausschnitt_01).jpg">https://commons.wikimedia.org/wiki/Trajan%27s_Column_-_Cichorius_Plates#/media/File:004_Conrad_Cichorius,_Die_Reliefs_der_Traians%C3%A4ule,_Tafel_IV_(Ausschnitt_01).jpg</a> , (accessed 6 April 2017).
Trajan's Column photo B	Cichorius, C., <i>Die Reliefs der Traianssäule</i> , Tafel V, Verlag von Georg Reimer, Berlin, 1896, <a href="https://commons.wikimedia.org/wiki/Trajan%27s_Column_-_Cichorius_Plates#/media/File:005_Conrad_Cichorius,_Die_Reliefs_der_Traians%C3%A4ule,_Tafel_V_(Ausschnitt_01).jpg">https://commons.wikimedia.org/wiki/Trajan%27s_Column_-_Cichorius_Plates#/media/File:005_Conrad_Cichorius,_Die_Reliefs_der_Traians%C3%A4ule,_Tafel_V_(Ausschnitt_01).jpg</a> , (accessed 6 April 2017).

## 6. Appendices

### 6.1. List of sites

In order to assess transparently the level of certainty for all the archaeological sites present in this study, I have classified them based on a criteria that takes into account 'status', 'dimensions' and 'type of finds'. For 'status', excavated sites receive a 1 value, but unexcavated ones a 0. For 'dimensions', sites with well established dimensions that point towards Roman military installations receive a 1 value, the other ones a 0, but linear defenses always have a 0. The reason behind doing this is that those sites are likely to produce less finds, especially if only surveyed, because they usually have no habitation layer. Therefore, their true nature cannot be established without excavations, which makes them riskier to interpret. Moreover, their lengths are irrelevant, because they can be as long as it would have been necessary. For 'type of finds', sites that yielded results during excavations or surveys receive a 2 value, but the other ones a 0. I believe a 2 value is relevant in this case, because artifacts are a safer indicator when evaluating the certainty of these sites than the previous 2.

Sites	Toponyms	Coordinates (WGS 84)	Plate no.	Notes	Status	Shape	Dimensions	Type of finds	Final certainty level (0-4)	Literature
Auxiliary fort	Cetate / Gradiște	46.88559° N 22.88463° E	Plate 1	auxiliary fort with stone rampart	excavated	rectangular	125 x 160 m (1st phase) 125 x 235 m (2nd phase) 133 x 213 m (3rd phase)	construction material, pottery, tools, coins, weapons, bones, etc.	4	Finály 1864, p. 6. Torma 1880, pp. 41-53. Radnóti 1944-45, p. 142. Gudea 1997, pp. 7-96. Marcu and Cupcea 2013, pp. 569-589. Marcu and Cupcea 2015, pp. 67-82.
Fortlet 1	La Tău	46.88282° N 22.85497° E	Plate 2	proved to be a natural feature	unexcavated	rectangular	-	-	0	Radnóti 1944-45, pp. 142-143. Ferenczi 1959, p. 340.
Fortlet 2	Cetatea Turcilor	46.95363° N 22.76614° E	Plate 3	possible fortlet with earth rampart	unexcavated	rectangular	44 x 46 m	coin	3	Finály 1864, p. 9. Torma 1880, pp. 52-53. Ferenczi 1959, pp. 347-348. Gudea 1985, p. 160.
Fortlet 3	Poieni	46.91207° N 22.86394° E	Plate 4	supposed fortlet with stone rampart - now gone	unexcavated	rectangular	50 x 47 m	construction material, pottery	3	Torma 1880, pp. 53-54. Téglás 1907, p. 572. Daicoviciu 1936, pp. 254-256. Ferenczi 1959, p. 344. Gudea 1985, pp. 160-161.
Fortlet 4	Vârful Șesului	46.89992° N 22.92301° E	Plate 5	possible fortlet with earth rampart	unexcavated	rectangular	100 x 70 m	construction material	3	Radnóti 1944-45, p. 144. Ferenczi 1959, pp. 349-350. Gudea 1985, p. 161.
Fortlet 5	Dosu Turcului / Cetate	46.94162° N 22.90009° E	Plate 6	possible fortlet with earth rampart	unexcavated	rectangular	40 x 30 m	-	1	Buday 1912, p. 108. Gudea 1985, p. 164.
Fortlet 6	Dealul Cocinilor	46.95490° N 22.89696° E	Plate 7	possible fortlet with earth rampart	unexcavated	rectangular	36 x 36 m	-	1	Buday 1912, p. 108. Gudea 1971, p. 519. Gudea 1985, p. 164.
Fortlet 7	La Arie	46.98612° N 22.91391° E	Plate 8	fortlet with earth rampart	excavated	rectangular	25 x 25 m	construction material, pottery	4	Téglás 1907, p. 576. Buday 1912, p. 109. Gudea 1985, p. 165.
Linear defenses 1	La Tău - Măgura Bologii	46.88702° N 22.85848° E	Plate 9	proved to be natural features	unexcavated	-	-	-	0	Radnóti 1944-45, p. 142. Ferenczi 1959, p. 340.
Linear defenses 2	Poieni-Horhiș / Carpân	46.91162° N 22.86721° E	Plate 10	earth rampart with 2 external ditches	excavated	-	-	posthole, pottery	3	Torma 1880, pp. 55-57. Téglás 1907, p. 573. Buday 1912, pp. 104-105. Daicoviciu 1936, pp. 254-256. Ferenczi 1959, p. 343. Gudea 1971, p. 509. Gudea 1985, p. 161.

Linear defenses 3	Carpân - Cetățea	46.91052° N 22.87748° E	Plate 11	proved to be a field division	unexcavated	-	-	-	0	Téglás 1907, p. 573-574. Buday 1912, pp. 106-107. Ferenczi 1959, p. 346.
Linear defenses 4	Cetățea - Dosu Marcului - Rimbușoiu	46.91388° N 22.88527° E	Plate 12	proved to be plow marks or similar	unexcavated	-	-	-	0	Téglás 1907, p. 573-574. Radnóti 1944-45, p. 143. Ferenczi 1959, p. 346.
Linear defenses 5	Vlasin	46.97539° N 22.89974° E	Plate 13	earth rampart signaled only once	unexcavated	-	-	-	0	Téglás 1907, p. 574-575
Watchtower 1	Măgura Bologii	46.88440° N 22.85801° E	Plate 14	stone watchtower	excavated	rectangular	7.5 x 7.5 m	construction material, pottery	4	Radnóti 1944-45, pp. 142-143. Ferenczi 1959, pp. 340-341. Gudea 1971, p. 509. Gudea 1985, p. 159. Marcu and Cupcea 2013, pp. 569-589.
Watchtower 2	Măgura Sebeșului	46.90191° N 22.84668° E	Plate 15	thought to be a stone watchtower	excavated	-	-	-	1	Ferenczi 1959, pp. 340-341. Gudea 1971, p. 509. Gudea 1985, pp. 159-160.
Watchtower 3a	Dâmbu Vărădeștilor	46.91125° N 22.86910° E	Plate 16	stone watchtower	excavated	rectangular	5.6 x 5.6 m	construction material, pottery, tools, weapon, bones	4	Téglás 1907, p. 573. Buday 1912, pp. 106-107. Ferenczi 1959, pp. 343-344. Gudea 1971, p. 509, 511. Gudea 1985, pp. 161-162. Marcu and Cupcea 2013, pp. 569-589.
Watchtower 3b	Dâmbu Vărădeștilor	46.91134° N 22.86909° E	Plate 16	stone watchtower	excavated	rectangular	5.5 x 5.5 m	construction material, pottery, tool	4	Téglás 1907, p. 573. Buday 1912, pp. 106-107. Ferenczi 1959, pp. 343-344. Gudea 1971, p. 509, 511. Gudea 1985, pp. 161-162. Marcu and Cupcea 2013, pp. 569-589.
Watchtower 4	Horbiș / Carpân	46.91030° N 22.87287° E	Plate 17	stone watchtower	excavated	rectangular	4.4 x 5.4 m	construction material, pottery	4	Torma 1880, p. 57. Téglás 1907, p. 573. Buday 1912, pp. 106-107. Ferenczi 1959, p. 345. Gudea 1971, p. 511, 513. Gudea 1985, p. 162. Marcu and Cupcea 2013, pp. 569-589.
Watchtower 5	Cetățea	46.91425° N 22.87614° E	Plate 18	stone watchtower	excavated	rectangular	5.25 x 5.25 m	construction material, pottery, coins, tool	4	Torma 1880, p. 57. Téglás 1907, p. 574. Buday 1912, p. 107. Ferenczi 1959, pp. 345-346. Gudea 1971, p. 513. Gudea 1985, p. 162. Marcu and Cupcea 2013, pp. 569-589.
Watchtower 6	Dosu Marcului	46.91603° N 22.88149° E	Plate 19	possible watchtower	excavated	-	-	pottery, burnt layer	3	Torma 1880, p. 58. Téglás 1907, p. 574. Buday 1912, p. 107. Radnóti 1944-45, p. 143. Gudea 1971, p. 513. Gudea 1985, pp. 162-163. Marcu and Cupcea 2013, pp. 569-589.
Watchtower 7	Rimbușoiu	46.92154° N 22.88674° E	Plate 20	stone watchtower	excavated	rectangular	6 x 6 m	construction material, pottery, tools, bones	4	Torma 1880, pp. 58-60. Téglás 1907, p. 574. Buday 1912, p. 107. Radnóti 1944-45, p. 143. Ferenczi 1959, p. 346. Gudea 1971, p. 513, 517. Gudea 1985, p. 163. Marcu and Cupcea 2013, pp. 569-589.
Watchtower 8	Dealul Bonciului	46.92708° N 22.88921° E	Plate 21	stone watchtower	excavated	round	7.8 m	construction material, pottery, tool, bones	4	Téglás 1907, p. 574. Gudea 1971, p. 517. Gudea 1985, p. 163. Marcu and Cupcea 2013, pp. 569-589.
Watchtower 9	Dealul Cornii	46.92862° N 22.90388° E	Plate 22	possible watchtower	unexcavated	-	-	construction material, pottery	2	Téglás 1907, p. 574. Buday 1912, p. 107. Gudea 1971, p. 517. Gudea 1985, p. 163. Marcu and Cupcea 2013, pp. 569-589.



Watchtower 10	Cornu Sonului	46.93783° N 22.90020° E	Plate 23	stone watchtower	excavated	rectangular	8.5 x 8.5 m	construction material, pottery	4	Torma 1880, pp. 58-60. Téglás 1907, p. 574. Buday 1912, pp. 107-108. Gudea 1985, pp. 163-164. Marcu and Cupcea 2013, pp. 569-589.
Watchtower 11	Vârful Grebănului	46.94537° N 22.89768° E	Plate 24	stone watchtower	excavated	rectangular	12.5 x 12.5 m	construction material, pottery, bones	4	Torma 1880, p. 61. Téglás 1907, p. 574. Buday 1912, p. 108. Gudea 1971, p. 517, 519. Gudea 1985, p. 164. Marcu and Cupcea 2013, pp. 569-589.
Watchtower 12a	Cornu Vlasinului	46.96841° N 22.89809° E	Plate 25	possible watchtower	excavated	-	-	construction material, pottery	3	Torma 1880, p. 61. Buday 1912, pp. 108-109. Gudea 1985, p. 165.
Watchtower 12b	Cornu Vlasinului	46.96854° N 22.89792° E	Plate 25	stone watchtower	excavated	round	6 m	construction material, pottery	4	Torma 1880, p. 61. Buday 1912, pp. 108-109. Gudea 1985, p. 164.
Watchtower 13	Capu Gribanu	46.98121° N 22.90178° E	Plate 26	possible watchtower	unexcavated	-	-	construction material, pottery	2	Téglás 1907, p. 575

## 6.2. List of plates

- Plate 1:
- The auxiliary fort near Bologa - below left (Resources and tools: GIMP; Google Earth 2011.1; QGIS; Soviet Topographic Maps 1: 50 000).
  - Site overview - below right (Literature: Gudea 1997, pp. 16-54, 79, 86, 96. Resources and tools: GIMP; Google Earth 2011.1; QGIS).

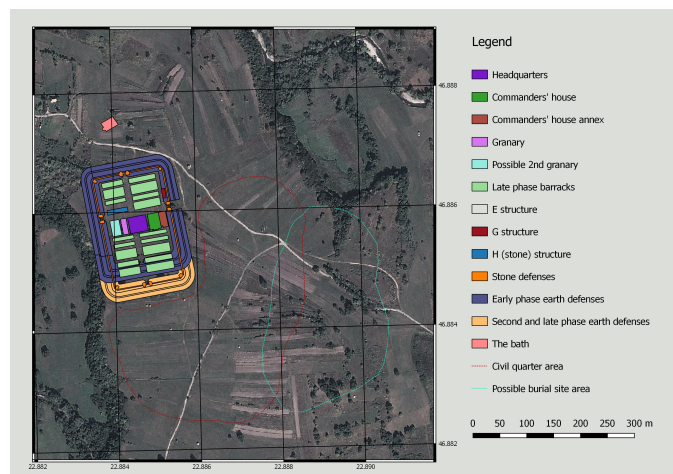
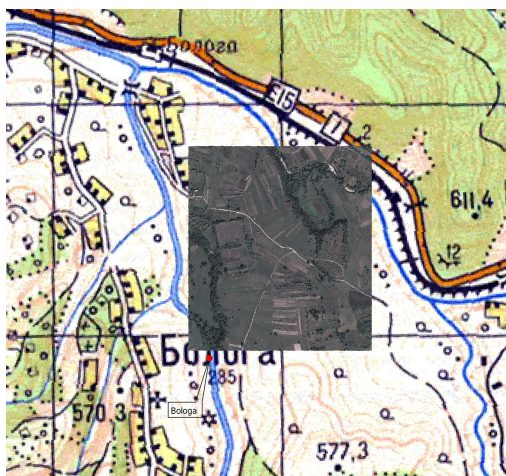

Plate 2: a). Fortlet 1 site overview (Resources and tools: GIMP; Google Earth 2011.2; QGIS).



Plate 3: a). Fortlet 2 site overview - below left (Resources and tools: ASTER Global DEM - 30 m; GIMP; Google Earth 2009.1; QGIS; Soviet Topographic Maps 1: 50 000).  
 b). Gudea's drawing showing its location - below right (Literature: Gudea 1985, p. 189).

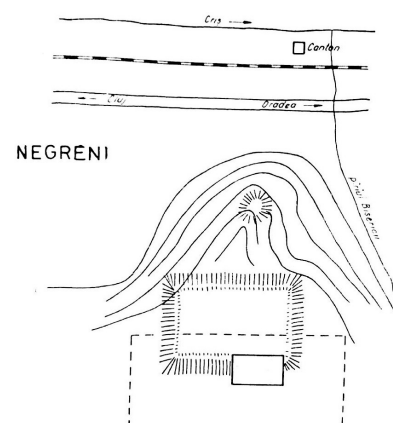

Plate 4:

- a). Fortlet 3 site overview - below left (Resources and tools: ASTER Global DEM - 30 m; GIMP; Google Earth 2009.2; QGIS; Soviet Topographic Maps 1: 50 000).
- b). Torma's drawing showing its former location - below right (Literature: Torma 1880, p. 55).

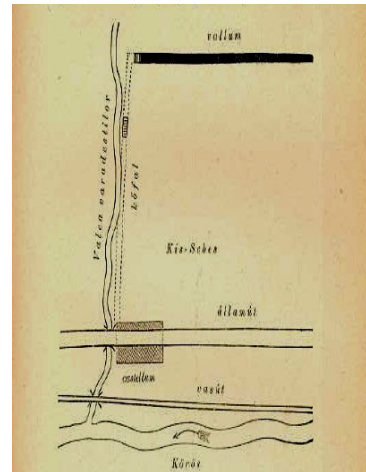

Plate 5:

- a). Fortlet 4 site overview - below left (Resources and tools: ASTER Global DEM - 30 m; GIMP; Google Earth 2011.3; QGIS; Soviet Topographic Maps 1: 50 000).
- b). Aerial photograph showing the site - below right (Literature: Radnóti 1944-45, p. 144).

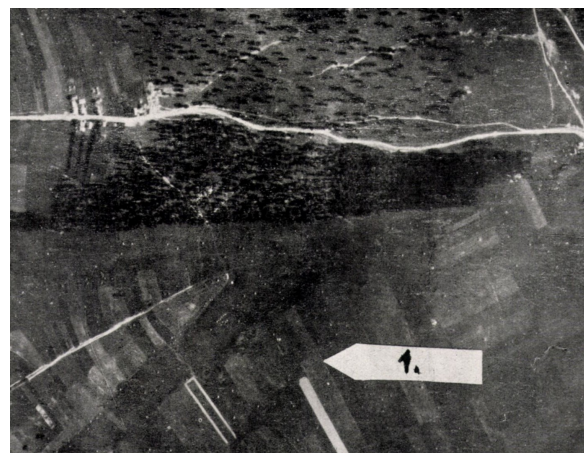
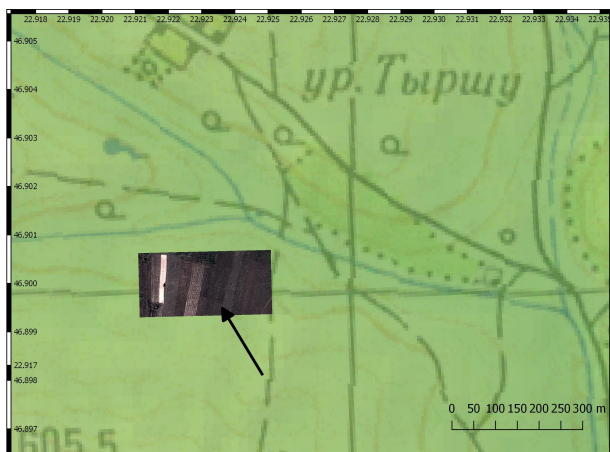



Plate 6:

- a). Fortlet 5 site overview - below left (Resources and tools: ASTER Global DEM - 30 m; GIMP; Google Earth 2009.3; QGIS; Soviet Topographic Maps 1: 50 000; SRTM Global DEM - 90 m).
- b). Marcu and Cupcea's site location - below right (Literature: Marcu and Cupcea 2015, p. 71. Resources and tools: ASTER Global DEM - 30 m; QGIS; Soviet Topographic Maps 1: 50 000).

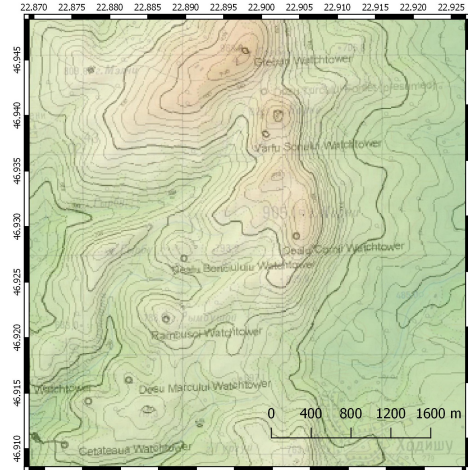

Plate 7:

- a). Fortlet 6 site overview (Resources and tools: GIMP; Google Earth 2009.4; QGIS).

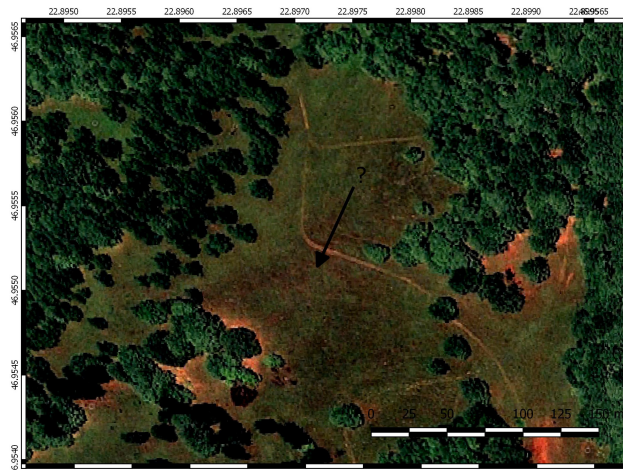
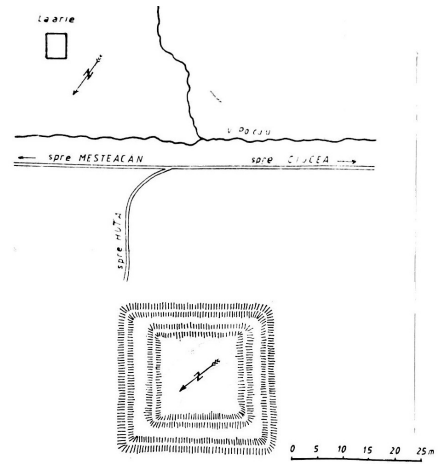
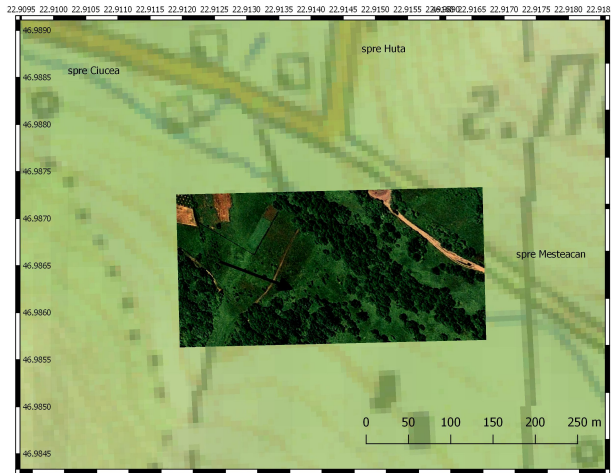

Plate 8:

- a). Fortlet 7 site overview - below left (Resources and tools: ASTER Global DEM - 30 m; GIMP; Google Earth 2009.5; QGIS; Soviet Topographic Maps 1: 50 000).
- b). Gudea's drawing showing its location, but he points to a different place, contrary to the text description from the same paper - below right (Literature: Gudea 1985, p. 196).



- c). Buday's terrestrial photograph showing the site - below left (Literature: Buday 1912, p. 106).
- d). The site viewed from a similar direction in Google Earth - below right (Resources and tools: GIMP; Google Earth 2009.6).

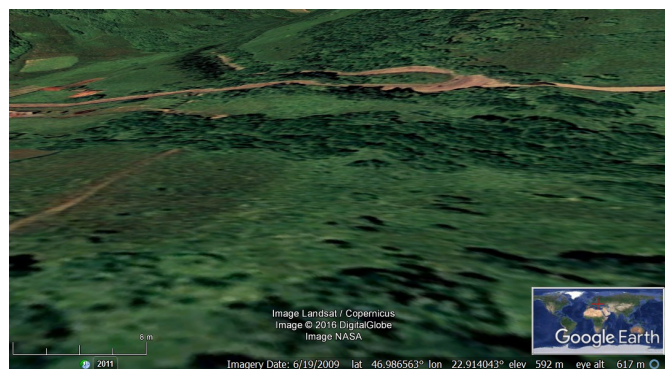



Plate 9:

a). Linear defenses 1 site overview - below left (Resources and tools: GIMP; Google Earth 2011.4; QGIS).

b). Aerial photograph covering the same area - below right (Literature: Radnóti 1944-45, p. 142).

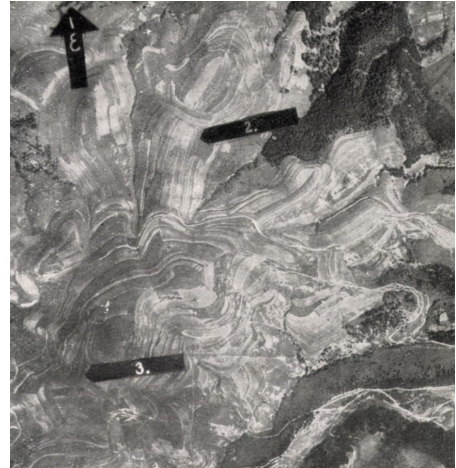

Plate 10:

a). Linear defenses 2 site overview (Resources and tools: GIMP; Google Earth 2009.7; QGIS).





Plate 11: a). Linear defenses 3 site overview (Resources and tools: GIMP; Google Earth 2009.8; QGIS).



Plate 12: a). Linear defenses 4 site overview - below left (Resources and tools: GIMP; Google Earth 2009.9; QGIS).  
b). Aerial photograph covering the same area - below right (Literature: Radnóti 1944-45, p. 143).

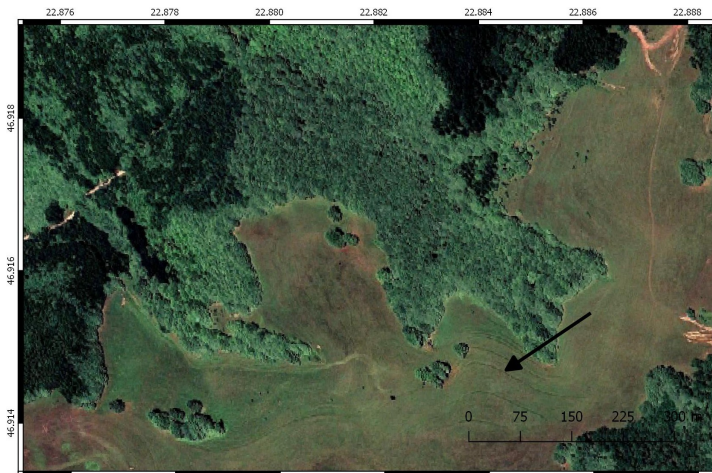

Plate 13:

a). Linear defenses 5 site overview (Resources and tools: GIMP; Google Earth 2009.10; QGIS).

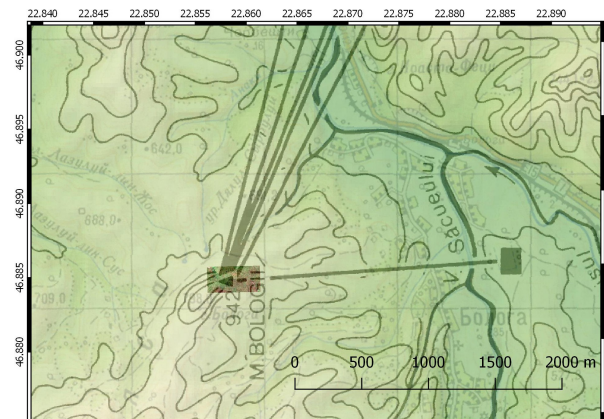
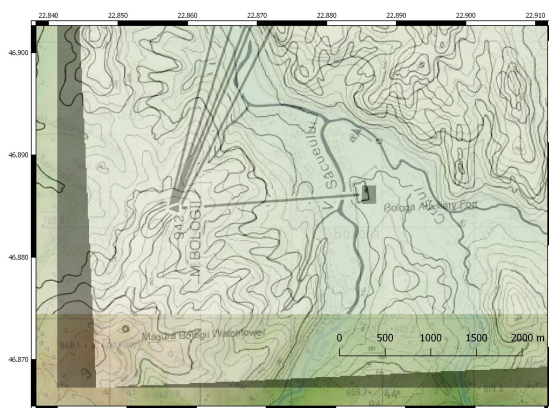

Plate 14:

a). Site location according to Marcu and Cupcea's map, in relation to Gudea's drawing - below left (Literature: Gudea 1979, p. 75; Marcu and Cupcea 2015, p. 71. Resources and tools: ASTER Global DEM - 30 m; GIMP; QGIS; Soviet Topographic Maps 1: 50 000).

b). Site location according to Gudea's drawing - below right (Literature: Gudea 1979, p. 75. Resources and tools: ASTER Global DEM - 30 m; GIMP; Google Earth 2009.11; QGIS; Soviet Topographic Maps 1: 50 000).

c). Watchtower 1 site overview, now hardly visible - below middle (Resources and tools: GIMP; Google Earth 2009.11; QGIS).





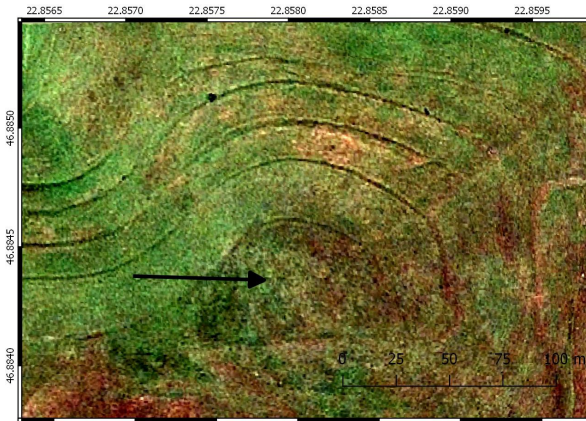

d). Aerial photograph showing the site - below left (Literature: Radnóti 1944-45, pp. 142-143).

e). Plan of the excavated site - below right (Literature: Gudea 1971, p. 509).

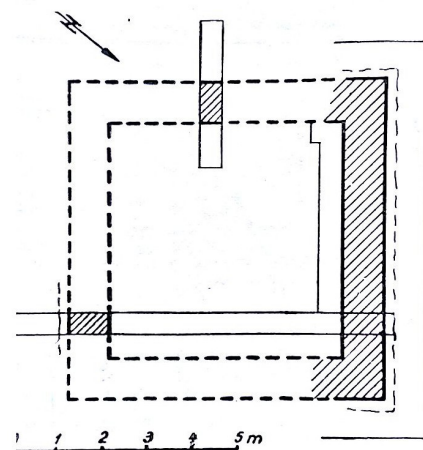
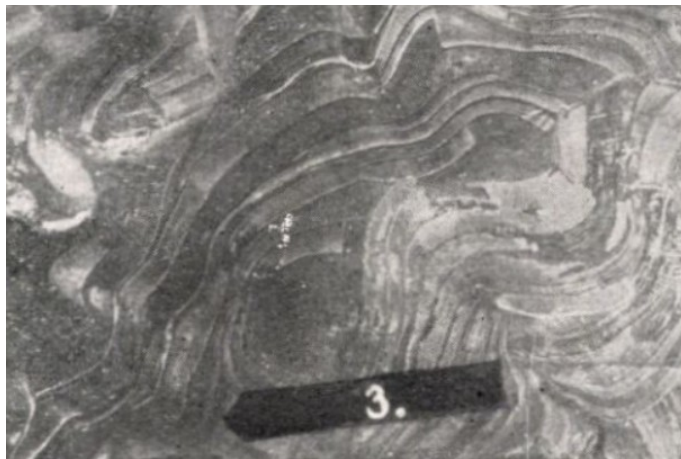

Plate 15:

a). Watchtower 2 approximate location (Resources and tools: ASTER Global DEM - 30 m; GIMP; Google Earth 2011.5; QGIS; Soviet Topographic Maps 1: 50 000; SRTM Global DEM - 90 m).





Plate 16:

a). Watchtowers 3a and 3b site overview with my acquisition  
(Resources and tools: GIMP; Google Earth 2009.12; GPS Coordinates Finder; QGIS).

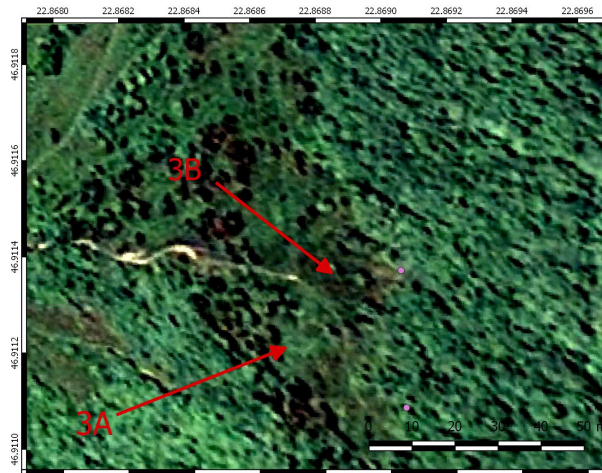

b). Photographs showing Watchtower 3a - 1st 2 below left, and 3b - below right (4 August 2016).



c). Plans of the excavated sites, Watchtower 3a - below left, 3b - below right (Literature: Gudea 1971, pp. 509-511).

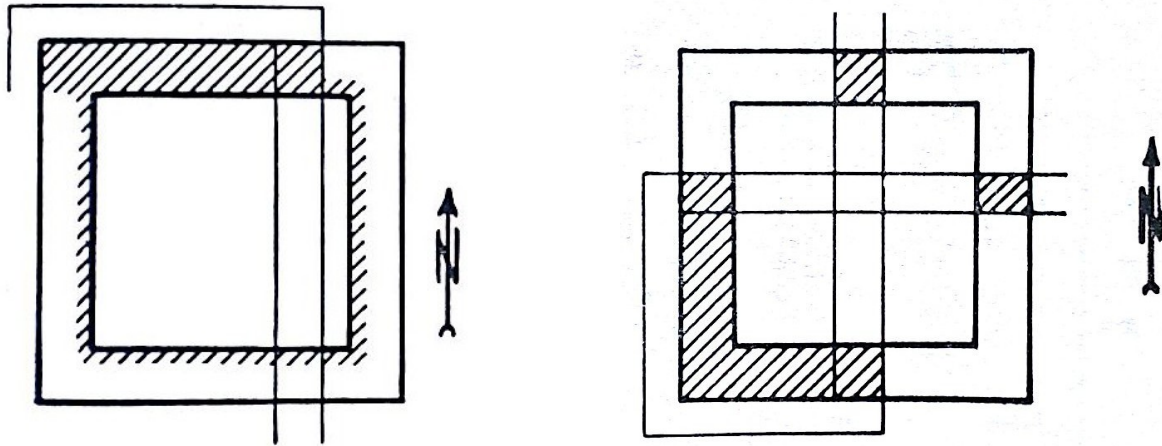
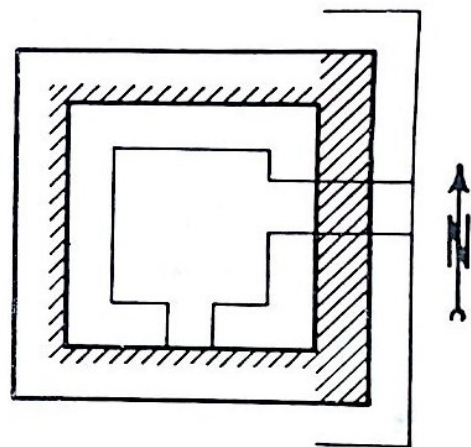
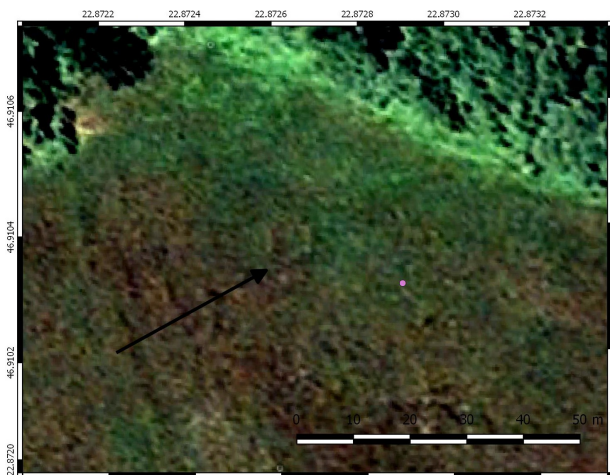

Plate 17: a). Watchtower 4 site overview with my acquisition - below left (Resources and tools: GIMP; Google Earth 2009.13; GPS Coordinates Finder; QGIS).  
b). Plan of the excavated site - below right (Literature: Gudea 1971, pp. 511-513).





c). Photographs showing the site - below (4 August 2016).



Plate 18:

a). Watchtower 5 site overview with my acquisition - below left (Resources and tools: GIMP; Google Earth 2011.6; GPS Coordinates Finder; QGIS).

b). Plan of the excavated site - below right (Literature: Gudea 1971, p. 513).

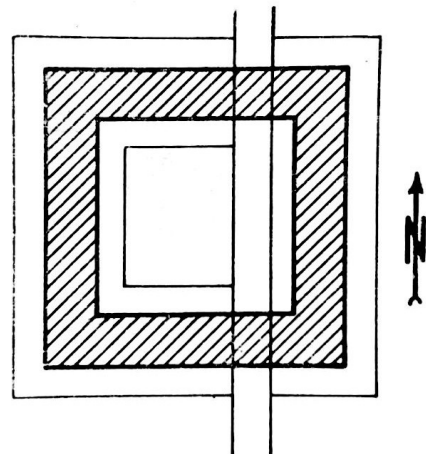



c). Photographs showing the site - below (8 August 2016).



Plate 19:

a). Watchtower 6 site overview with my acquisition - below left  
(Resources and tools: GIMP; Google Earth 2011.7; GPS Coordinates Finder; QGIS).

b). Photographs showing the site - below right (8 August 2016).



Plate 20:

- a). Watchtower 7 site overview with my acquisition - below left (Resources and tools: GIMP; Google Earth 2011.8; GPS Coordinates Finder; QGIS).  
b). Plan of the excavated site - below right (Literature: Gudea 1971, pp. 513-517).

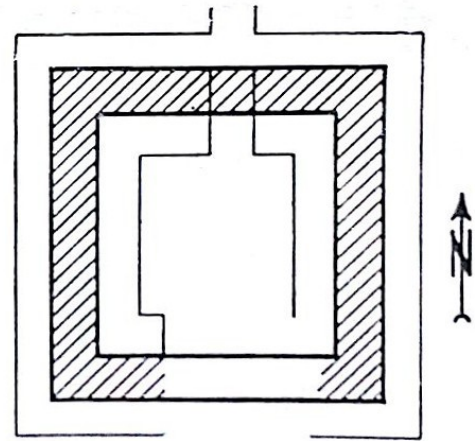

- c). Aerial photograph showing the site - below left (Literature: Radnóti 1944-45, p. 143).  
d). Photographs showing the site - below right (8 August 2016).





Plate 21:

- a). Watchtower 8 site overview - below left (Resources and tools: ASTER Global DEM - 30 m; GIMP; Google Earth 2011.9; QGIS; Soviet Topographic Maps 1: 50 000; SRTM Global DEM - 90 m).
- b). Marcu and Cupcea's site location - below right (Literature: Marcu and Cupcea 2015, p. 71. Resources and tools: ASTER Global DEM - 30 m; QGIS; Soviet Topographic Maps 1: 50 000).

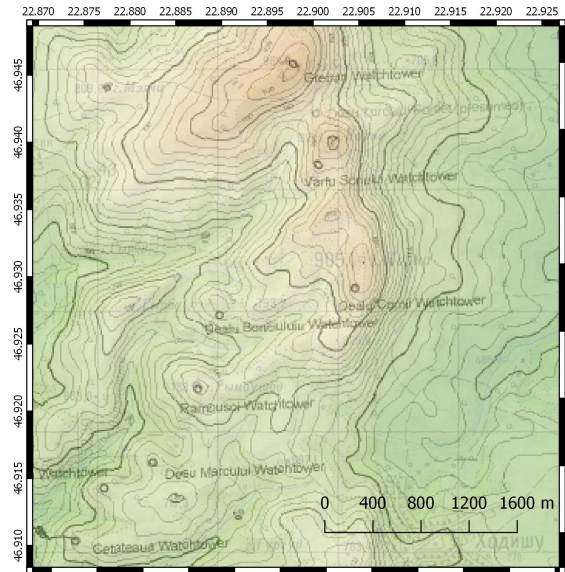
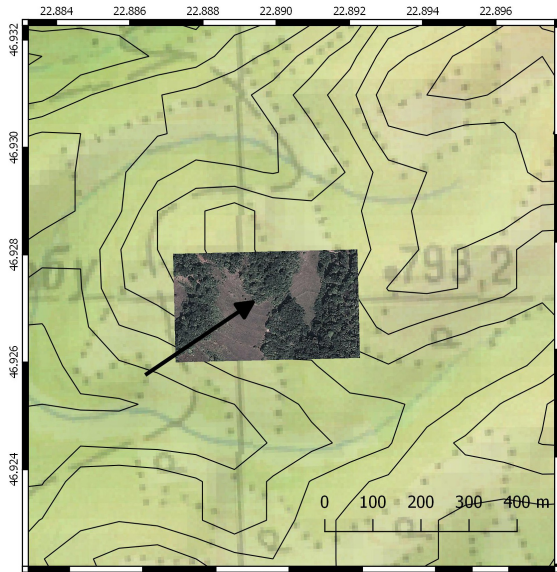

- c). Plan of the excavated site - below left (Literature: Gudea 1971, p. 517).
- d). Photograph showing the site - below right (8 August 2016).

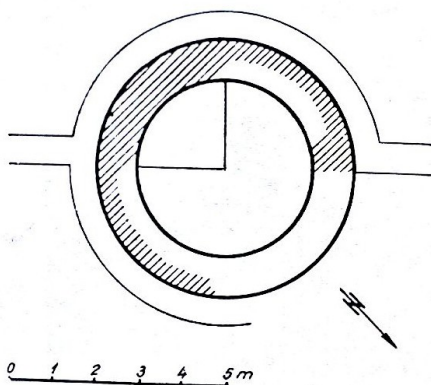



Plate 22:

- a). Watchtower 9 site overview - below left (Resources and tools: ASTER Global DEM - 30 m; GIMP; Google Earth 2009.14; QGIS; Soviet Topographic Maps 1: 50 000; SRTM Global DEM - 90 m).
- b). Marcu and Cupcea's site location - below right (Literature: Marcu and Cupcea 2015, p. 71. Resources and tools: ASTER Global DEM - 30 m; QGIS; Soviet Topographic Maps 1: 50 000).

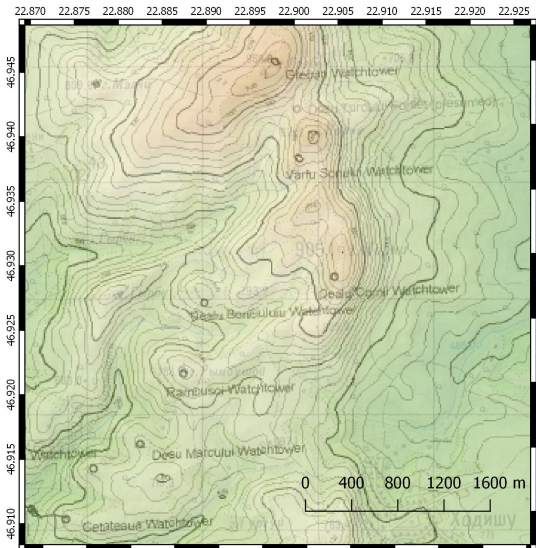
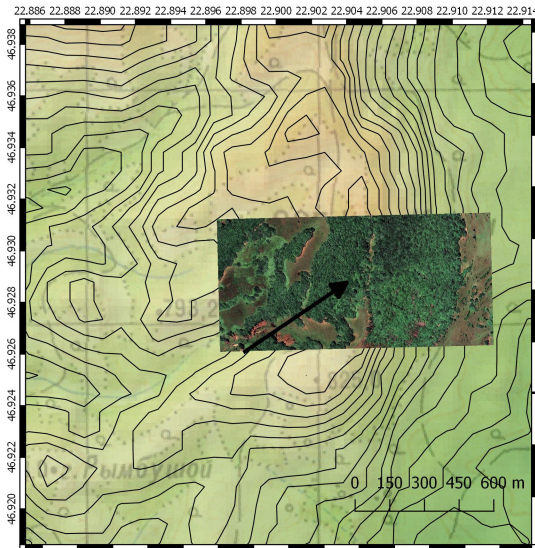
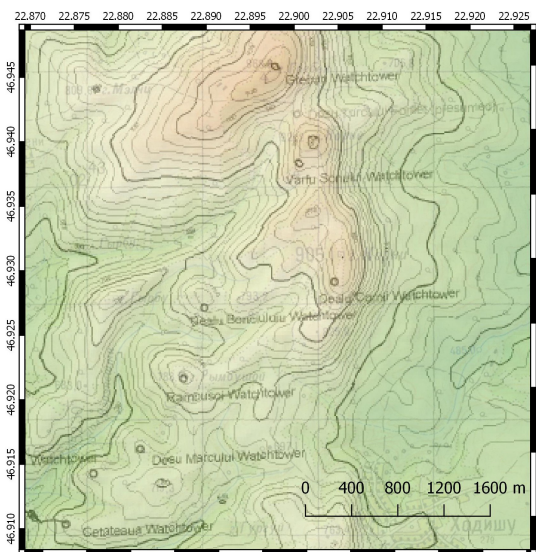
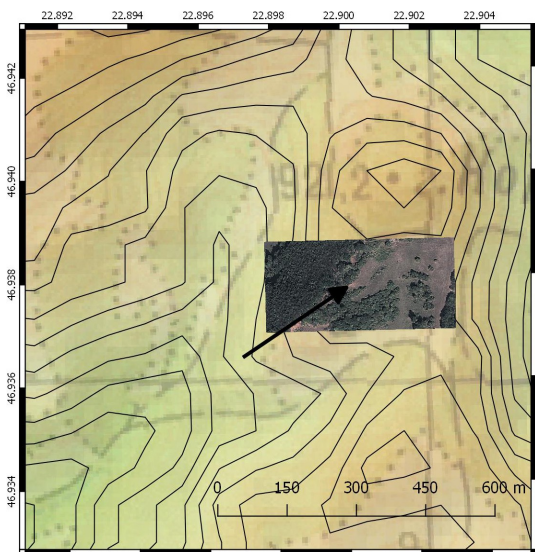

Plate 23:

- a). Watchtower 10 site overview - below left (Resources and tools: ASTER Global DEM - 30 m; GIMP; Google Earth 2011.10; QGIS; Soviet Topographic Maps 1: 50 000; SRTM Global DEM - 90 m).
- b). Marcu and Cupcea's site location - below right (Literature: Marcu and Cupcea 2015, p. 71. Resources and tools: ASTER Global DEM - 30 m; QGIS; Soviet Topographic Maps 1: 50 000).



c). Plan of the excavated site - below (Literature: Gudea 1985, p. 194).

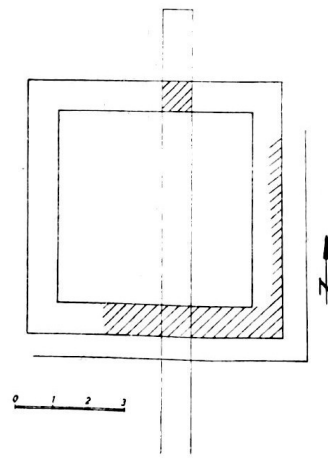
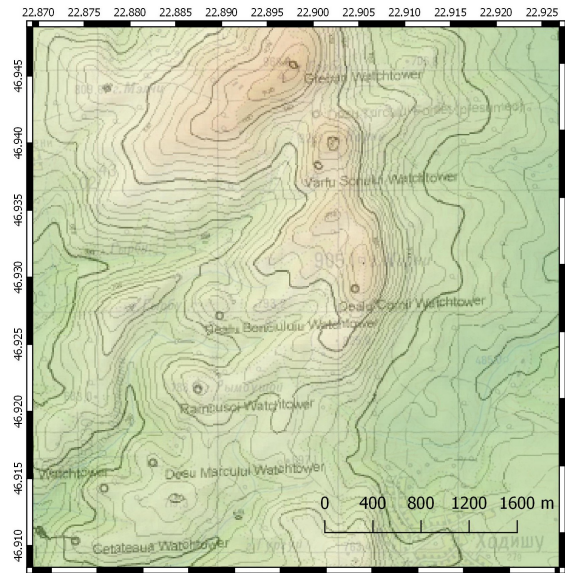
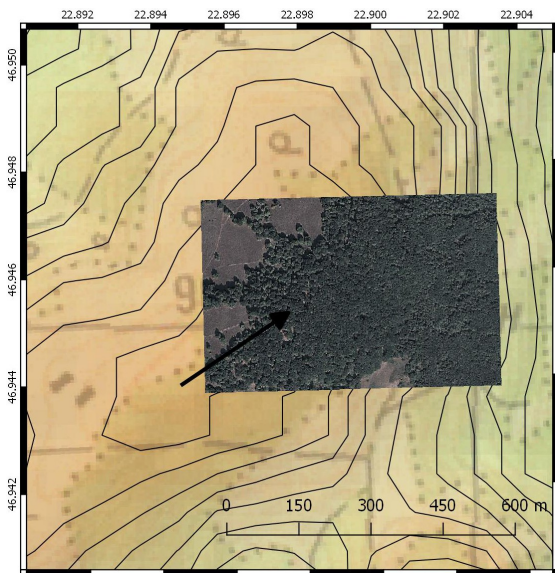

Plate 24:

- a). Watchtower 11 site overview - below left (Resources and tools: ASTER Global DEM - 30 m; GIMP; Google Earth 2011.11; QGIS; Soviet Topographic Maps 1: 50 000; SRTM Global DEM - 90 m).
- b). Marcu and Cupcea's site location - below right (Literature: Marcu and Cupcea 2015, p. 71. Resources and tools: ASTER Global DEM - 30 m; QGIS; Soviet Topographic Maps 1: 50 000).





c). Plan of the excavated site - below (Literature: Gudea 1985, p. 195).

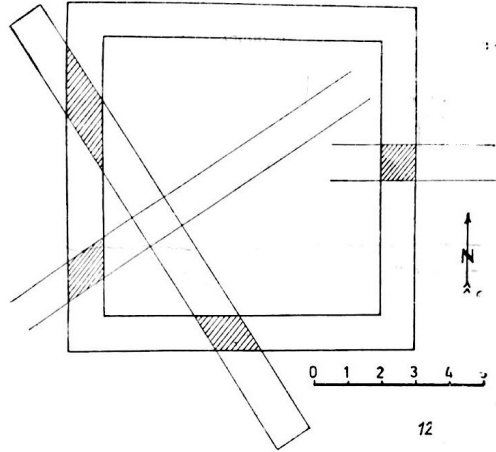
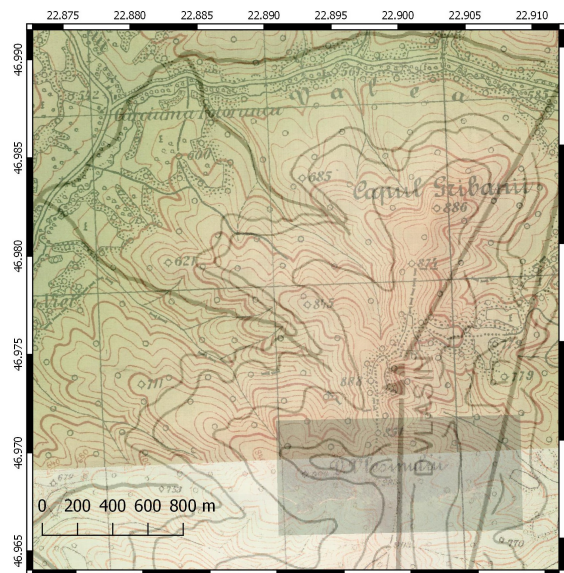
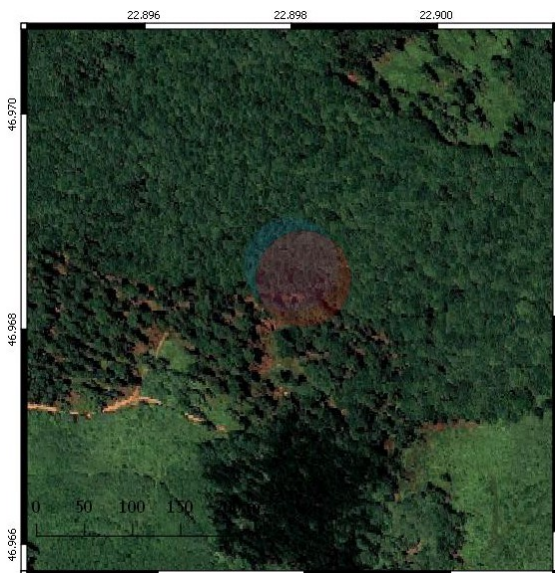

Plate 25:

a). Watchtowers 12a and 12b approximate location - below left (Resources and tools: GIMP; Google Earth 2009.15; QGIS).

b). Site location according to Gudea's drawing, but the towers should be somewhat to the south according to the label and the text description - below right (Literature: Gudea 1979, p. 75. Resources and tools: GIMP; Google Earth 2009.15; QGIS; Romanian Topographic Maps 1: 20 000).





c). Plan of Watchtower 12b - below (Literature: Gudea 1985, p. 195).

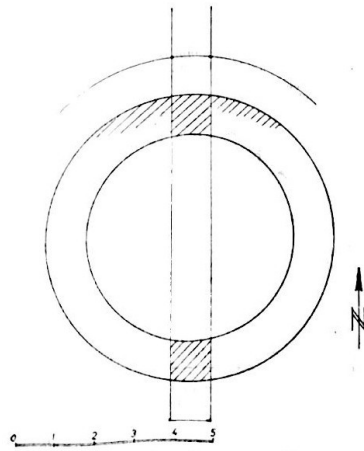
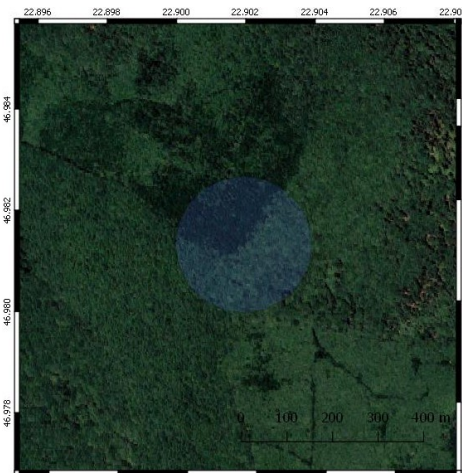

Plate 26:

a). Watchtower 13 approximate location (Resources and tools: GIMP; Google Earth 2009.16; QGIS).



### 6.3. List of figures

- Figure 1. Locations discussed in subchapter 1.1. Background.
- Figure 2. Locations discussed in subchapter 1.2. Research history.
- Figure 3. The study area with all the archaeological sites.
- Figure 4. Ranges that model the distance decay in fuzzy viewsheds.
- Figure 5. Relationship between distance and size of viewed objects measured in visual arc.

- Figure 6. Formulas showing how  $b1 + b2$  is determined based on the size of the viewed object, as well as how to obtain a target size-sensitive fuzzy membership.
- Figure 7. Examples of crossover lengths ( $b1 + b2$ ) for objects with different sizes given different visual arcs.
- Figure 8. Visual comparison between ASTER and SRTM 1 arcsec showing the noisiness.
- Figure 9. Geological profile showing the slope difference.
- Figure 10. Representations from Trajan's and Marcus Aurelius' columns.
- Figure 11. Examples of reconstructed watchtowers.
- Figure 12. Watchtower 1 binary viewshed.
- Figure 13. Watchtower 1 fuzzy viewshed with 1' visual arc.
- Figure 14. Watchtower 1 fuzzy viewshed with 2' visual arc.
- Figure 15. Watchtower 1 fuzzy viewshed with 3' visual arc.
- Figure 16. Watchtower 3a binary viewshed.
- Figure 17. Watchtower 3a fuzzy viewshed with 1' visual arc.
- Figure 18. Watchtower 3a fuzzy viewshed with 2' visual arc.
- Figure 19. Watchtower 3a fuzzy viewshed with 3' visual arc.
- Figure 20. Watchtower 3b binary viewshed.
- Figure 21. Watchtower 3b fuzzy viewshed with 1' visual arc.
- Figure 22. Watchtower 3b fuzzy viewshed with with 2' visual arc.
- Figure 23. Watchtower 3b fuzzy viewshed with 3' visual arc.
- Figure 24. Watchtower 3a's binary viewshed in comparison with Watchtower 1's.
- Figure 25. Watchtower 3b's binary viewshed in comparison with Watchtower 1's.
- Figure 26. Watchtower 4 binary viewshed.
- Figure 27. Watchtower 4 fuzzy viewshed with 1' visual arc.
- Figure 28. Watchtower 4 fuzzy viewshed with 2' visual arc.
- Figure 29. Watchtower 4 fuzzy viewshed with 3' visual arc.
- Figure 30. Watchtower 4's binary viewshed in comparison with Watchtower 1's and 3a's.
- Figure 31. Watchtower 5 binary viewshed.
- Figure 32. Watchtower 5 fuzzy viewshed with 1' visual arc.
- Figure 33. Watchtower 5 fuzzy viewshed with 2' visual arc.
- Figure 34. Watchtower 5 fuzzy viewshed with 3' visual arc.
- Figure 35. Watchtower 5's binary viewshed in comparison with Watchtower 1's, 3a's and 4's.
- Figure 36. Watchtower 7 binary viewshed.
- Figure 37. Watchtower 7 fuzzy viewshed with 1' visual arc.
- Figure 38. Watchtower 7 fuzzy viewshed with 2' visual arc.
- Figure 39. Watchtower 7 fuzzy viewshed with 3' visual arc.
- Figure 40. Watchtower 7's binary viewshed in comparison with Watchtower 5's.
- Figure 41. Watchtower 8 binary viewshed.

- Figure 42. Watchtower 8 fuzzy viewshed with 1' visual arc.  
 Figure 43. Watchtower 8 fuzzy viewshed with 2' visual arc.  
 Figure 44. Watchtower 8 fuzzy viewshed with 3' visual arc.  
 Figure 45. Watchtower 8's binary viewshed in comparison with Watchtower 5's and 7's.  
 Figure 46. Watchtower 10 binary viewshed.  
 Figure 47. Watchtower 10 fuzzy viewshed with 1' visual arc.  
 Figure 48. Watchtower 10 fuzzy viewshed with 2' visual arc.  
 Figure 49. Watchtower 10 fuzzy viewshed with 3' visual arc.  
 Figure 50. Watchtower 10's binary viewshed in comparison with Watchtower 7's and 8's.  
 Figure 51. Watchtower 11 binary viewshed.  
 Figure 52. Watchtower 11 fuzzy viewshed with 1' visual arc.  
 Figure 53. Watchtower 11 fuzzy viewshed with 2' visual arc.  
 Figure 54. Watchtower 11 fuzzy viewshed with 3' visual arc.  
 Figure 55. Watchtower 11's binary viewshed in comparison with Watchtower 1's, 7's and 10's.  
 Figure 56. Watchtower 12b binary viewshed.  
 Figure 57. Watchtower 12b fuzzy viewshed with 1' visual arc.  
 Figure 58. Watchtower 12b fuzzy viewshed with 2' visual arc.  
 Figure 59. Watchtower 12b fuzzy viewshed with 3' visual arc.  
 Figure 60. Watchtower 12b's binary viewshed in comparison with Watchtower 11's.  
 Figure 61. Cumulative viewshed.  
 Figure 62. Comparison between all studied watchtowers' number of visible cells in the binary, fuzzy 1' visual arc, 2' visual arc and 3' visual arc viewsheds.  
 Figure 63. Binary viewshed intervisibility results.  
 Figure 64. Fuzzy viewshed with 1' visual arc intervisibility results.  
 Figure 65. Fuzzy viewshed with 2' visual arc intervisibility results.  
 Figure 66. Fuzzy viewshed with 3' visual arc intervisibility results.  
 Figure 67. Comparison between the number of visible watchtowers from each studied structure.  
 Figure 68. The military camps of the Roman province of Dacia and the frontiers

#### 6.4. List of tables

- Table 1. Results of the reconstructed heights.  
 Table 2. Number of visible cells found in the binary and fuzzy viewsheds.  
 Table 3. Binary and fuzzy viewshed intervisibility results.