

Master Thesis
TVVR 17/5022

Modeling LID-units in SWMM

- A review of the current approach with suggestions for improvement

Petter Mogenfelt



Division of Water Resources Engineering
Department of Building and Environmental Technology
Lund University

Modeling LID-units in SWMM

- A review of the current approach
with suggestions for improvement

By:
Petter Mogenfelt

Master Thesis

Division of Water Resources Engineering
Department of Building & Environmental
Technology Lund University
Box 118
221 00 Lund, Sweden

Water Resources Engineering
TVVR-17 /5022
ISSN 1101-9824

Lund 2017
www.tvrl.lth.se

Master Thesis
Division of Water Resources Engineering
Department of Building & Environmental Technology
Lund University

Swedish title: Modellering av LOD-enheter i SWMM
English title: Modeling LID-units in SWMM

Author: Petter Mogenfelt

Supervisor: Rolf Larsson (Lund University, Sweden)
Rob James (CHI, Canada)

Examiner: Ronny Berndtsson (Lund University, Sweden)

Language: English

Year: 2017

Keywords: SWMM, DRAINMOD, storm water modeling, LID, LOD,
SUDS, bio-retention cells, EPA, underdrains

Acknowledgements

This project has allowed me to cross an ocean, learn, grow and explore a new continent. I thank my supervisor Rolf Larsson at LTH for initiating the cross-Atlantic correspondence that made this possible and all the support that I have been given along the way.

I want to thank the James family in Guelph. Rob, for taking me in and sharing the resources at CHI. Bill, for lending me a wonderful green bike and being a great ambassador for the Swedish-Canadian relationships. Furthermore, I want to thank everyone else at CHI in Guelph. I got to learn PCSWMM from you, attend a conference with you and see the amazing work that you do at CHI on a daily basis. You shared your vast knowledge and made me feel welcome and at home in Guelph. Thank you for the cakes, ice-skating, canoe trip and Friday night drinks. It has been a true pleasure getting to know you all.

Jay Dorsey and Ryan Winston, thank you for sharing your research and taking the time to guide me through the early stumbling steps of this project. Your insights and deep knowledge has been invaluable for me.

I also want to extend my gratitude to the City of Calgary and Miao Yu for providing me with data and model for this project.

Finally, I want to thank family and friends for always being there to support me through this process.

Abstract

The LID control in US EPA SWMM5 include modeling of Green-Ampt infiltration through the soil layer which assumes that only matrix flow is present. The LID control also models drainage through perforated underdrains. In this study, data and premade PCSWMM models, utilizing the SWMM5 engine, were provided for two test sites in North America. The models showed limitations in modeling soil flow and the comprehensiveness of modeling underdrains. Literature research and runs with modifications to the PCSWMM models indicated that macropore flow was also present for both sites due to the in-situ observed rapid percolation response. Furthermore, the underdrain flow modeling in the LID control was perceived as insufficient in addition to lacking options for two outlets. Hence, modified code with additional options was developed for the underdrain code in the LID control including partially submerged orifices, Manning's equation and dual outlets. The code was tested in the provided models with promising results. Although dual outlets are not commonly mentioned in design manuals, the results in the study showed potential gains both in terms of water treatment and reduced peak flows.

Sammanfattning

LOD-modulen i amerikanska EPA SWMM5 inkluderar Green-Ampt-modellering av infiltration genom jordlagret vilket antar att flöde endast sker genom mediet. LOD-modulen modellerar också dräneringsflöde genom perforerade dräneringsrör. Data och förberedda PCSWMM-modeller som använder SWMM-motorn förseddes för två testanläggningar i Nordamerika. Modellerna visade på begränsningar i modelleringen av flöde genom jordlagret och dräneringsrör. Studier av relevant litteratur och test av modifierade versioner av PCSWMM-modellerna indikerade att flöde även skedde genom makroporer i jordlagret, vilket stöddes av in-situ-mätningar som visade snabb perkolation till det undre gruslagret. Modelleringen av flöde genom dräneringsrör upplevdes dessutom som otillräcklig och saknade möjlighet att modellera LOD med dräneringsrör som har två utlopp. Modifierad SWMM-kod för dräneringsrör utvecklades därmed med ytterligare alternativ för flöde genom delvis fyllda utlopp, Mannings ekvation och dubbla utlopp. Koden testades i de försedda modellerna med lovande resultat. Trots att dubbla utlopp inte nämns mycket i designmanualer så visar studien på vinster både i vattenrening och minskade maxflöden.

Table of Contents

Acknowledgements	iii
Abstract	v
Sammanfattning.....	vii
Table of Contents	ix
1 Introduction	1
1.1 Background	1
1.2 Terminology and referenced papers	2
1.3 Problem description.....	2
1.4 Objectives.....	3
1.5 Method.....	3
1.6 Limitations.....	3
2 Literature review.....	4
2.1 Common designs of LIDs.....	4
2.1.1 Bio-retention cells	4
2.1.2 Infiltration trenches	5
2.1.3 Permeable pavements	5
2.1.4 Underdrains	6
2.2 LID-hydrology.....	7
2.3 Underdrain hydraulics	10
2.4 LID Modeling.....	11
2.4.1 SWMM.....	11
2.4.2 DRAINMOD	14
3 Improving LIDs in SWMM	16
3.1 Two outlets	16
3.2 Partially submerged orifice.....	17
3.3 Manning's equation.....	19
3.4 Developing new code	20

4	Case studies	21
4.1	Ursuline college.....	21
4.1.1	Site description	21
4.1.2	Model descriptions	23
4.1.3	Model limitations.....	26
4.2	Calgary	28
4.2.1	Site description	28
4.2.2	Model descriptions	29
4.2.3	Model limitations.....	31
5	Results	32
5.1	Ursuline College.....	32
5.1.1	Calibrated model fit.....	32
5.2	Calgary	35
5.2.1	Calibrated model fit.....	35
5.2.2	The dual outlet approach	40
6	Discussion and conclusion.....	41
7	Suggested research.....	44
8	References	45
	Appendix, SWMM code.....	49

1 Introduction

1.1 Background

SWMM (Storm Water Management Model) is one of the most widely used software for storm water modeling. SWMM is released by the US Environmental Protection Agency (EPA) (Lucas, 2013) but the development of the official releases has been made with contributions from both EPA and academic institutions as well as private corporations. The first version, SWMM1, was released in 1971 and the latest release, SWMM5, was released in 2005 (Rossman & Huber, 2016a). During recent years, the application of LID solutions (Low Impact Development) have seen a sharp rise (Fletcher, et al., 2014). SWMM5 was updated with a discrete tool for LID modeling in 2009, in order to allow further assessment of the impacts from implementing LIDs (McCutcheon & Wride, 2013). The US EPA defines LID as a set of practices engineered to mitigate the effects of storm water run off (US EPA, 2012).

The LID control in SWMM5 includes an option to add an underdrain for several types of LIDs. The underdrain is stated to have the intention of preventing flooding by controlling the outflow from the storage (Rossman & Huber, 2016b). Correct design of the underdrain for a specific LID unit will help towards keeping ponding time, CSO (combined sewer overflow) and other common storm water system design criteria within its limits (New York State, 2015).

The complexity of modeling underdrain flow leads to vastly different approaches being used in available computer models depending on their usage. In several models, such as SWMM, it is assumed that the flow is limited by either the capacity of the pipe or an outlet orifice. Thus, applying the orifice equation or Manning's formula (Rossman & Huber, 2016b). Models using head driven flow, such as SWMM, typically have explicit LID-features, while DRAINMOD is an example of a modeling software designed for modeling agricultural water balance. Thus, it is developed for drainpipes laid in finer soils where the low conductivity of the soil causes the water table to slope notably towards the drain, which leads to a more complex modeling approach of underdrain flow (Skaggs, 1980). Although not explicitly developed for LIDs, DRAINMOD has been successfully implemented for continuous modeling of several sites, including bio-retention cells and permeable pavement (Hunt, et al., 2013); (Smolek, et al., 2015). A limitation in DRAINMOD is that it has relatively big time steps and only reports output at the end of each day (Hunt, et al., 2013).

1.2 Terminology and referenced papers

As this report is written for and by the assistance of SWMM users, that will also reflect the choice of terminology throughout the report. Hence, where terminology is not defined, it is used in accordance with published manuals and other guidance from EPA and other SWMM-affiliated resources. The aforementioned applies especially on the usage of the definition of different types of LID practices and the term LID which is favored in American sources, while the same type of practices are also commonly referred to as e.g. Sustainable Urban Drainage Systems (SUDS), Green Infrastructure (GI) or Storm Water Control Measures (SCM) depending on the source and origin.

A major part of the research advances on LID practices are conducted and presented in North America. Both SWMM and DRAINMOD, which constitute a major part of the focus in this report, are developed in the United States. Consequently, most of its users are found in North America. The concentration of users and expertise in the region will also to a big degree be reflected in the choice of research papers and design manuals that are reviewed in this report.

1.3 Problem description

Although LID controls are still a fairly recent addition to SWMM, they have undergone several updates in the last years (CHI WATER, 2017). For this reason, many of the recommendations made in published reports and online discussions on improved LID-modeling in SWMM have quickly been made obsolete, simply because they have already been added in subsequent updates to the software. Updates include better accounting for flow through LIDs under flooded conditions in 5.1.007 and allowing for separate routing of the underdrain flow in 5.1.008. However, some concerns that have been raised are still highly relevant, such as the difficulties to represent conduit outlets from LIDs in SWMM (Winston, 2015). As research on DRAINMOD is indicating advantages of its more complex modeling of soil water conditions there is reason to believe that the soil layer in SWMM could be exceedingly simplified for some LID designs, which in turn impacts the flow through the underdrain.

1.4 Objectives

The goal of this thesis is to define and explain the limitations of modeling the flow from perforated underdrains with the SWMM LID module and develop improvements to the code. Additionally, the scope extends to the assumptions and settings regarding infiltration in the soil layer of LID units. The limitations that are found during research will be analyzed and followed with suggestions for a modified approach that relate well to LID hydrology as well as the hydraulics in the underdrain and outlet. The suggestions will aim to allow users of SWMM to model underdrains in LIDs with a comprehensive approach that adequately corresponds to existing design standards and common practices.

1.5 Method

Available research on design and hydrology of LID as well as underdrain hydraulics will be thoroughly studied and presented in a literature review. Design manuals for LID design will be used as a reference for how different types of LIDs are designed. Furthermore, the modeling approach for LIDs, especially related to underdrain flow, will be presented briefly for SWMM and DRAINMOD. The review of related research and current modeling approaches will be followed by suggestions for code changes which are believed to be applicable and enhancing for SWMMs modeling of underdrains in the LID-control. By utilizing provided data sets from previously researched test sites, a set of models will be developed in PCSWMM. The models are going to be used to motivate the enhancing capabilities of the suggested code changes as well as highlighting limitations in the SWMM LID control.

1.6 Limitations

Only LID practices that are placed in the ground and include underdrains will be included in the literature review. Thus, vegetative swales, green roofs and several other LID practices will not be mentioned. Nevertheless, there are similarities between the aforementioned practices and those that are mentioned in this section of the report, which could potentially allow the reader to derive information for a wider spectrum of practices.

2 Literature review

2.1 Common designs of LIDs

2.1.1 Bio-retention cells

Figure 2.1 shows a typical design of a bio-retention cell with an underdrain placed in the gravel layer. Some construction guidance from major design manuals are presented in this chapter (Center for Watershed Protection, 2013); (Malmö Stad, 2008); (Gloucester City Council, 2013). These criteria are specific for the region they are developed for. Some of the criteria might therefore not apply well for regions with a different climate.

- For safety reasons the slope towards the bio-retention cell should be 33% or less.
- 2-3 inches (2.5-7.5 cm) of mulch is generally recommended on top of the soil media.
- 18 inches (47 cm) - 6 feet (183 cm) soil media thickness.
- 2 - 4 inches (5 – 10 cm) filter/choking layer.
- 6 inches (15 cm) – 4 feet (123 cm) gravel layer, laid at least 2 feet (61 cm) above the water table.
- 4 – 8 inches (10 – 20 cm) diameter underdrain where exfiltration is not sufficient.
- Construct with a small slope (< ~6 %)

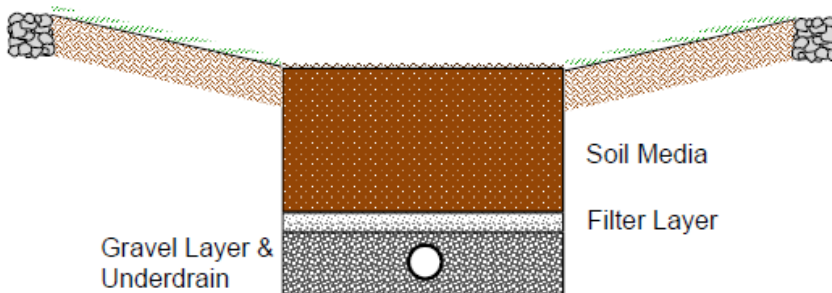

Figure 2.1. Typical bio-retention design (Dorsey, 2017)

2.1.2 Infiltration trenches

Infiltration trenches are essentially bio-retention cells without a soil layer. Consequently, they are not designed for plant growth nor ponding. Thickness of the drained storage layer is calculated to facilitate a design storm. Slope should be limited to about 15 % (New York State, 2015).

2.1.3 Permeable pavements

Permeable pavements are designed to function over time with both mechanical load and eroding particles from the pavement entering the sublayers. Thus, they generally have a sand layer instead of fine grained particles as in a bio-retention cell to avoid compaction and clogging (Woods Ballard, et al., 2015). Several different layers may be used to provide sufficient infiltration, water storage and structural properties. Underdrains are placed and sized according to design flow criteria and to avoid damage from traffic loads.

If the pavement is constructed on a slope, the bottom surface of the LID should be made as flat as possible by constructing it with internal check dams to promote even distribution and infiltration of storm water (Center for Watershed Protection, 2013).

2.1.4 Underdrains

The general purpose of underdrains is to allow the LID-unit to drain within a given time, ranging between 24 and 72 hours. New York State (2015) gives a shorter drain time of 48 hours for PP-systems as compared to 72 hours. The shorter time is motivated by the risk of problems with the pavement layer for long saturation times.

There is a wide range of underdrain designs for LID practices. The pipe could be straight or with an upturned outlet to form an internal water storage (IWS) to increase denitrification (Washington State University Extension, 2012). See Figure 2.3 for an illustration. Woods Ballard, et al., (2015) also provides guidelines for a fin drain outlet from porous pavements. Fin drains are placed on the side of the LID unit with a vertical collector along its wall.

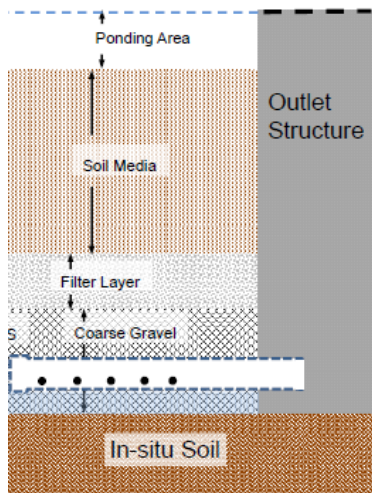

Figure 2.2. Straight underdrain without IWS (Dorsey, 2017)

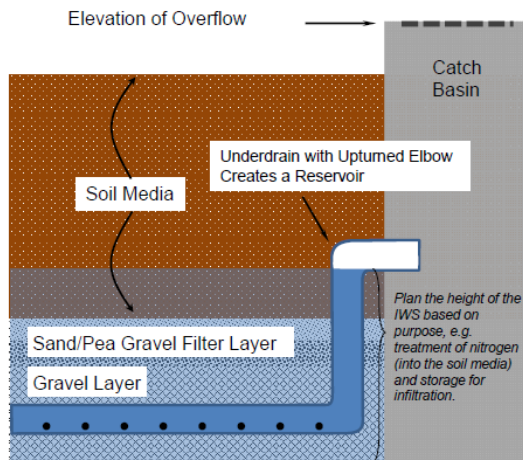

Figure 2.3. Upturned underdrain outlet to create an internal water storage (Dorsey, 2017)

Some LID guides recommend oversized underdrains which do not control the outflow while other recommend an orifice at the outlet to control the underdrain flow (Credit Valley Conservation, 2012); (City of Philadelphia, 2014). Although not found in design manuals, research has also been made that suggests combining a lower orifice controlled outlet with an outlet at a higher elevation, to allow maximum detention of normal events while also preventing overflow for peak flows (Lucas, 2013).

Woods Ballard, et al., (2015) recommends the underdrain placement relative to the bottom of the LID to be governed by the design criteria. Some affecting criteria are whether the LID should include an IWS and whether high exfiltration is desired.

For wide LID units, several underdrains are recommended to be placed in parallel, spaced 20 feet (6 m) apart (City of Philadelphia, 2014). The drains should also be placed with a minimum slope of 0.5 % (New York State, 2015).

2.2 LID-hydrology

Vertical transmission of storm water through a soil can be categorized by two widely different processes; matrix and macropore flow, where matrix flow is the movement through small connected soil pores and macropore flow is movement through larger pathways. These pathways can be e.g. worm holes, root channels and cracks from freeze-thaw cycles (Beven & Germann, 1982).

Assuming only matrix flow, the infiltration into a dry soil is governed by the suction capacity of the top soil, which depends on the soil properties and degree of saturation (Fetter, 2001). The suction capacity is often referred to as the matric potential, largely made up of gravitation and the negative energy of the soil particles. While gravitational pull remains constant, the negative soil energy will gradually be depleted as it saturates. Consequently, the infiltration rate is at its highest for completely dry soils and reaches its lowest values when the soil is saturated and only gravitation drives flow. Several methods for calculating the process of infiltration into the soil matrix and percolation vertically through the soil has been developed. Darcy's law is generally accepted for saturated flow in soils. Darcy's law is developed with the assumption that the soil is homogeneous and isotropic (Maidment, 1993). Furthermore, it is only valid when flow through the soil is slow enough to remain laminar (Fetter, 2001). Darcy's law is given in equation 2.1:

$$q = -K \frac{dH}{dz} \quad (2.1)$$

Where

K = hydraulic conductivity of the specific soil (m/s)

dH/dz = change in head per length in direction of flow

For unsaturated conditions, solutions range from the physically based Richards equation which combines Darcy's law with mass conservation to more empirical solutions such as the Green-Ampt and Horton equations. Solving the Richards equation can only be done by finite-difference or finite-element methods. While Maidement (1993) mentions software able to do the calculations, it is generally viewed upon as demanding too much computational power for larger models (Rossman & Huber, 2016b); (Skaggs, 1980). Green-Ampt uses the conception of a saturated wetting front forming in the top layer and moving through the soil. The thickness of the wetted zone is the accumulated infiltration F in equation 2.2:

$$f = K \left[1 + \left(\frac{S_f(\phi - \theta_i)}{F} \right) \right] \quad (2.2)$$

Where

- K = effective hydraulic conductivity (m/s)
- S_f = effective suction (m)
- ϕ = soil porosity (%)
- θ_i = initial water content (%)
- F = accumulated infiltration (m)

Hortons equation is based on an infiltration rate decreasing from a value f_0 for a dry soil to f_c as the soil moisture increases. It is however only applicable when there is water available to infiltrate at least at a rate f_c . Hortons equation is presented in equation 2.3:

$$f_p = f_c + (f_0 - f_c) * e^{-\beta t} \quad (2.3)$$

Where

- β = recession curve shape parameter (h^{-1})

All these theories assume that air can escape the soil pores without resistance, which does not hold true for all cases. Maidement (1993) points out that Morel-Seytoux and Noblanc developed equations for two-phase flow which accounts for the resistance of entrapped air. However, he also mentions that it is difficult to assign the necessary parameters which means that the approach is not viable for most practical applications. Even so, Morel-Seytoux and Khanji (1975) also showed that the accuracy of Green-Ampt could be improved by simply dividing the infiltration rate with a soil specific correction factor.

If macropore flow is also introduced, complexity grows further. Beven & Germann (1982) describes how pores with a range of formation types, having diameters up to 50 mm, are found at depths of several meters. Thus, macropores will likely be a notable factor for infiltration in many LIDs. While the work of Beven and Germann (1982) has been much cited, theirs and others research on macropore theory has had little effect on the emergence of new computer models (Weiler, 2017). Lucas (2013) argues that macropores can have a big impact on infiltration rates in bio-retention cells but that the effect is reduced for soils with bigger grain sizes. He further motivates the effect of macropore flow by giving examples of cases where early outflow has been observed, much earlier than suggested by matrix flow using the laboratory measured saturated conductivity of the soil. Furthermore, he presents research data showing how infiltration rates has increased over time, indicating a gradual development of macropores. Weiler (2017) comments that preferential flow due to macropores can be accounted for to some degree by calibrating available models for matrix flow. However, the calibrated model will often give poor predictions when applied to future scenarios. Explicit calculation and calibration for preferential flow would be necessary to adequately model a full range of scenarios. Weiler (2017) suggests that matrix-based equations derived from the Richards equation, such as Green-Ampt, should be coupled with discrete accounting for macropores.

As described by Maidment (1993), Holtan developed a method of calculating infiltration rates which suggests that plant growth should be considered, thereby accounting for preferential flow resulting from root paths that are developed in the top upper part of the soil (Maidment, 1993). The final form of the equation is:

$$f_p = GIaSA^{1.4} \quad (2.4)$$

Where

f_p = infiltration capacity (m/s),

SA = available storage in the surface layer. A function of degree of saturation and surface layer thickness (m)

GI = growth index of crop in percent of maturity

a = an index of surface connected porosity, function of surface conditions and density of plant roots (s^{-1})

The surface layer thickness was suggested as plow layer depth for agriculture, which makes the parameter highly arbitrary for an LID-unit.

The importance of accounting for the effect of macropores on infiltration rates was also commented on by Lucas (2013), claiming that “Vegetation can under some conditions have a substantial effect on infiltration rates, largely due to formation of macropores”. However, instead of mentioning methods to calculate flow with account to macropores, Lucas (2013) claims that flow rates through a soil layer cannot be predetermined due to the number of influencing variables.

2.3 Underdrain hydraulics

A range of different equations have been developed to calculate pipe flow, one of the more common being Manning’s equation. With the assumption of uniform flow, Manning’s equation can be applied for any given flow depth (Maidment, 1993). However, due to having inflow from perforations along the drain, theory of spatially varied flow is strictly more representative of underdrain hydraulics (Mohammadzadeh-Habili & Mostafazadeh-Fard, 2009). The applicability of Manning’s equation is also dependent on the outlet conditions.

While Manning’s equation is not necessarily accurate for many flow conditions, it is still used for modeling of conditions with spatially varied inflow, such as rainfall on a green roof in SWMM (Rossman & Huber, 2016b). An advantage is that computation is simple and requires little input, which is also easily attained. In contrast, more analytical solutions such as the one for spatially varied flow suggested by Mohammadzadeh-Habili & Mostafazadeh-Fard (2009) add complexity. Hence, Manning’s equation still has an advantage in computational efficiency and user friendliness but should be used with caution.

Lucas (2013) argues that the complexity of soil hydrology effectively makes it impossible to predetermine average conductivity. Thus, it also prohibits the use of soil conductivity to engineer an LID with a certain draw down time. An outlet control could instead be used to calibrate the detention to the design goals. Research on outlet controls have shown clear benefits and consequently been recommended for LID-design (Lucas & Sample, 2014); (Guo & Luu, 2015). Both Lucas & Sample (2014) and Guo and Luu (2015) use an orifice as outlet control, thus calculating outflow with the standard head dependent orifice equation. The head applied to the outlet will be affected by losses along the flow path. Especially, losses in the soil media will impact the total head (Lucas, 2013). Another factor to consider is the perforations on the drain pipe which, if the orifice equation is not applied directly on the perforations, should instead be accounted for as a head loss in the system.

2.4 LID Modeling

2.4.1 SWMM

LID units in SWMM are represented as either separate subcatchments or as a fraction of the impervious part of a subcatchment (Rossman & Huber, 2016b). The LID is separated in equal-depth layers with only vertical movement of water within and between the layers. Three types of LID-options are within the scope of the thesis; bio-retention cell, permeable pavement (PP) and infiltration trench. The illustration in Figure 2.4 depicts a conceptual model of the processes that SWMM accounts for in a bio-retention cell which can be related to the design in Figure 2.1. All drained LID units in SWMM have a similar structure with the difference that permeable pavements (PP) include a pavement layer on top of the soil and that infiltration trenches do not have any soil layer included.

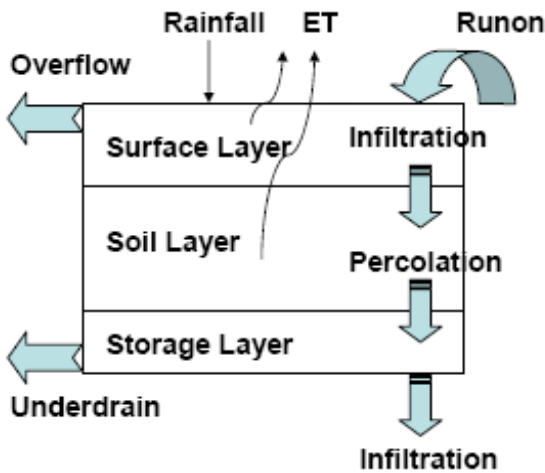

Figure 2.4. Conceptual model of a bio-retention cell in SWMM (Rossman & Huber, 2016b).

Evapotranspiration (ET) for LIDs is using the same daily potential ET rate as in the SWMM runoff module which allows for several types of input and computations (Rossman & Huber, 2016b). Actual ET is calculated for all layers starting with the surface layer and total ET being limited to the potential ET. Hence, if the ET of overlying layers equals the potential ET for a given time step, no ET will occur in that layer. Potential ET can be given as daily, monthly or constant input. It can also be calculated from daily temperatures (Rossman & Huber, 2016a).

Infiltration within the LID module is equal to the rainfall intensity until saturation occurs on the surface (Rossman & Huber, 2016a). When a saturated layer is formed, infiltration is calculated with the Green-Ampt equation which is also one of the options in the groundwater module. Green-Ampt infiltration is further described in section 2.3. Green-Ampt infiltration creates a wetted front which moves downward into the soil layer and percolates into the storage layer with a velocity determined by Darcy's law and a calibration parameter for unsaturated conditions:

$$q = K_s e^{-(\phi - \theta) * HCO} \quad (2.5)$$

Where:

K = saturated hydraulic conductivity (m/s)

ϕ = soil porosity (%)

θ_i = moisture content (%)

HCO = Calibration parameter, referred to as conductivity slope in SWMM (-)

In the conceptual model presented in Figure 2.4, the downward movement is represented by the percolation arrow.

Utilizing Darcy's law means that matrix flow is assumed and no account is taken for the potential effect of macropores. The groundwater module also includes Curve number and Horton infiltration; they are however excluded as an option for LIDs. Furthermore, the LID-module only allows the user to model its site with vertical walls that has no hydrologic connection with the surrounding soil. In practice, this means that an impermeable liner is assumed and all exfiltration (infiltration leaving the storage layer in Figure 2.4) is assumed to leave the unit through the base at a constant rate.

Drain flow in SWMM LIDs is calculated internally as mm/s and the underdrain equation includes three parameters and calculates flow as a function of the hydraulic head which is simplified to the height of saturated water above the drain offset, see equation 2.6.

$$q = C(h)^n \quad (2.6)$$

Where:

- q = underdrain flow (mm/s)
- C = underdrain discharge coefficient (mm⁻⁽ⁿ⁻¹⁾/sec)
- h = hydraulic head seen by the underdrain (mm)
- n = underdrain discharge exponent

The screenshot shows a software interface for configuring LID (Low Impact Development) controls. On the left, a list titled 'LID controls:' contains one entry, 'LID', which is highlighted. Below this list are 'Add' and 'Del' buttons. On the right, the configuration details for the selected 'LID' are shown. The 'Name' field contains 'LID'. The 'LID type' is set to 'Bio-Retention Cell' via a dropdown menu. Below this are four tabs: 'Surface', 'Soil', 'Storage', and 'Underdrain', with 'Underdrain' currently selected. Under the 'Underdrain' tab, there are three input fields: 'Drain coefficient (mm/hr)' with a value of 0, 'Drain exponent' with a value of 0.5, and 'Drain offset height (mm)' with a value of 6. At the bottom of the configuration area, a note reads: 'Note: Use a drain coefficient of 0 if the LID unit has no underdrain.' At the very bottom of the window are 'OK' and 'Cancel' buttons.

Figure 2.5. Current setup window for underdrains in SWMM (Rossman & Huber, 2016b).

This computational approach for underdrain flow in SWMM is motivated by e.g. computational limitations and which parts of the LID unit that is assumed to limit the drainage flow (Rossman & Huber, 2016b). The reference manual for LIDs suggest the assumption of head driven, fully submerged orifice flow or full pipe flow according to Manning's formula. The underdrain settings presented in Figure 2.5 would therefore be a drain exponent of 0.5 or 0 for the respective cases. The orifice flow approach can then be applied on either an outlet control or on the slots/perforations from which water enters the underdrain. Furthermore, the underdrain equation only gives the maximum flow. The final drain flow output is limited by e.g. available water above the drain invert, See Rossman & Huber (2016b) for a detailed explanation of the drain equation.

2.4.2 DRAINMOD

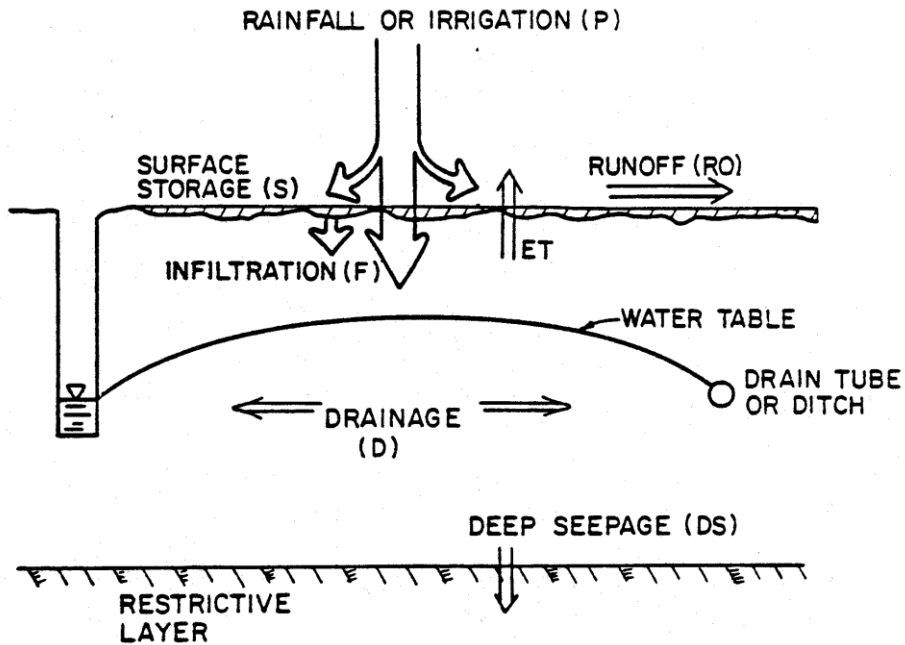

Figure 2.6. Conceptual illustration of DRAINMOD infiltration (Skaggs, 1980).

Brown, et al. (2011) claims that among the available modeling software, none perform adequately for bio-retention cells. Depending on the approach, some models are best fit for design storms events while other perform better for continuous modeling. Brown, et al. (2011) Further claims that DRAINMOD has the most comprehensive way of modeling the movement of water through the soil media.

Being an agricultural drainage model, DRAINMOD differs in a variety of ways from models such as SWMM, which is built for urban storm water management. In DRAINMOD, horizontal flow in the saturated zone is assumed to have a substantial effect on underdrain flow rates (Skaggs, 1980). Hence, DRAINMOD takes on a two-dimensional approach as opposed to the one-dimensional SWMM model. Additionally, DRAINMOD assumes that underdrains are oversized and that the flow is instead limited by the flow rate towards the drains. Consequently, the modeling approach for partly unsaturated soil conductions is to utilize the Hooghoudt equation:

$$q = \frac{8Kd_e m + 4Km^2}{CL^2} \quad (2.7)$$

Where

- K = Horizontal, saturated hydraulic conductivity (m/s)
- d_e = Equivalent depth parameter depending on drain radius (m)
- m = Water table level midway between drains (m)
- C = Flow distribution coefficient (%)
- L = Distance between drains (m)

If the soil is fully saturated and ponding is occurring, DRAINFLOW uses Kirkham's equation instead:

$$q = \frac{4\pi K(t + b - r)}{gL} \quad (2.8)$$

Where

- t = ponded depth (m)
- b = depth to drain (m)
- r = drain radius (m)
- g = dimensionless factor, determined by drain radius, drain offset from an assumed impermeable soil bottom and total soil depth

DRAINMOD also accounts for a specified root depth, which creates an upper dry zone. Infiltration is however, as in SWMM, calculated with the Green-Ampt equation (Skaggs, 1980). Skaggs (1980) recognizes the comprehensiveness of the Richards equation and proceed to state that while it is not appropriate for DRAINMOD, Green-Ampt has proven to give similar results for a range of different soils and inflow rates.

3 Improving LIDs in SWMM

The dual outlet design and a more comprehensive approach for underdrain flow with options for orifice or Manning flow are suggested as additions to SWMM to improve LID modeling. These options are motivated in section 3.2 and 3.3.

3.1 Two outlets

The difficulties presented in section 2.3 regarding attaining sought for retention times in a constructed LID motivates the underdrain approach suggested by Lucas (2013). The combination of a lower outlet control and a second larger elevated outlet provides the engineer with the option to optimize the LID without being concerned with perfecting soil infiltration. Being able to also model the dual outlet design in modeling software such as SWMM is important for efficient optimization, especially for larger projects with several LIDs. The dual outlet approach is depicted in Figure 3.1.

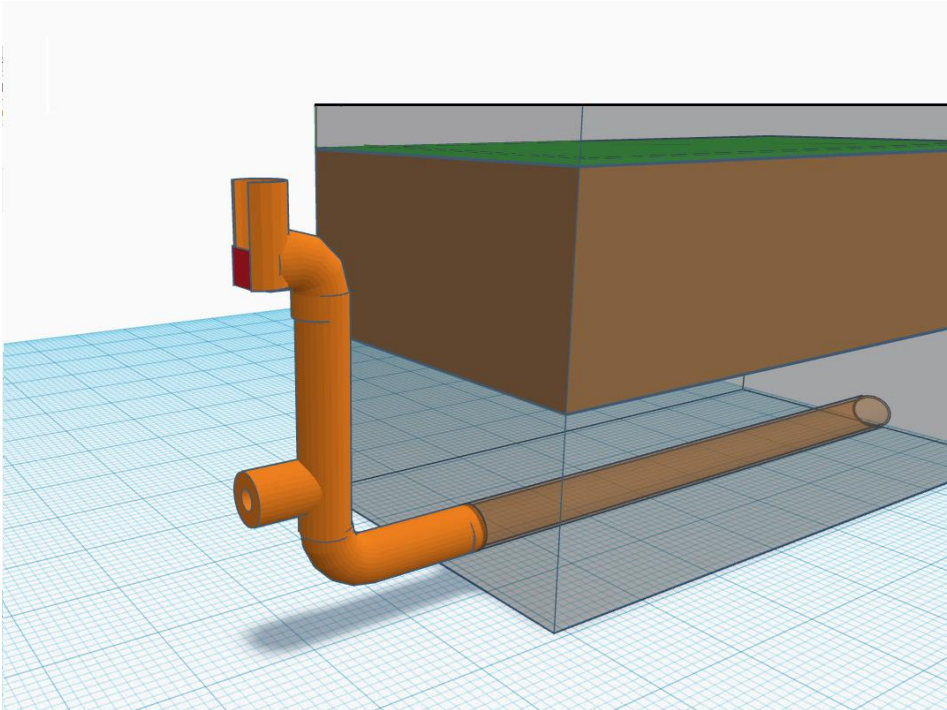

Figure 3.1. A conceptual view of the dual outlet approach proposed by Lucas (2013). Illustration by author.

3.2 Partially submerged orifice

As mentioned in section 2.5.1, the underdrain in SWMM LIDs is modeled with the assumption of flow in the full cross section of the outlet. As the water table rises during rain events, the outlet will however initially only be partially submerged. There are complex equations developed for partially submerged orifices available. However, MacKenzie (2015) showed that a good approximation can be made with a simplified equation as:

$$Q = Q_{\text{full}}(y/d)^{1.8} \quad (3.1)$$

where

y = water depth above orifice invert
d = orifice diameter

Outside of LID-units, SWMM already computes orifice flow for partially submerged conditions with a similar equation. The only difference being that the exponent is 1.5, as for a weir:

$$Q = Q_{\text{full}}(y/d)^{1.5} \quad (3.2)$$

The differences in computed flow between the two equations are small, as can be seen in Figure 3.2. The good agreement suggests that the current computation of partially submerged orifices in SWMM is sufficiently accurate and could therefore be utilized in the LID-module. The main purpose of adding discrete calculations for orifice flow is to provide the user with a comprehensive modeling approach for underdrains with outlet controls.

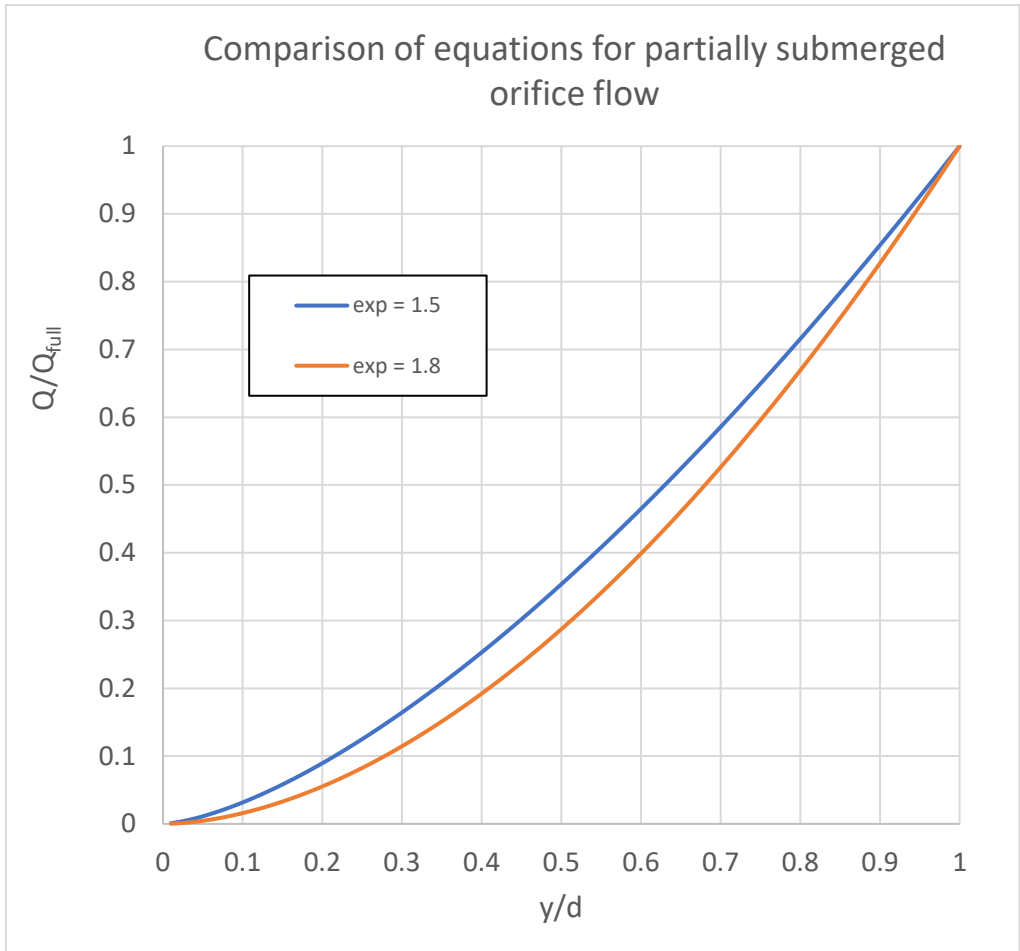

Figure 3.2. Comparison of calculating flow for partially submerged orifices as a fraction of fully submerged flow with a power of 1.5 or 1.8.

3.3 Manning's equation

The most accurate approach for calculating flow in a pipe which is not running full depends on whether the flow is laminar or turbulent, steady or unsteady, uniform or varied as well as sub- or supercritical (Watters, et al., 1995). As is being argued in section 2.4, the Manning's equation is not necessarily the most accurate method of calculating underdrain flow while the ease of use makes it attractive still. As mentioned in section 2.2.4, underdrains are commonly oversized to allow full infiltration. If flow control is utilized on the outlet, an orifice cap is typically used instead of downsizing the pipe. Consequently, the outlet flow from an LID without outlet control is typically limited by soil parameters rather than the outlet pipe. Thus, the accuracy of the calculation method for conduit flow from LIDs has no or only a limited impact on the computed drain flow. The current approach is however highly non-representative for conduit flow which can be problematic under some circumstances. The standard setting in SWMM of exponent $n = 0.5$ which at low applied head produces an output several magnitudes higher than that of typical flow calculations for pipes not running full. This can be shown by a comparison with Manning's equation for an underdrain with 20 cm diameter for rising head, see Figure 3.3. The discrepancy between the two equations motivates a second option for modelling underdrain flow with the Manning equations.

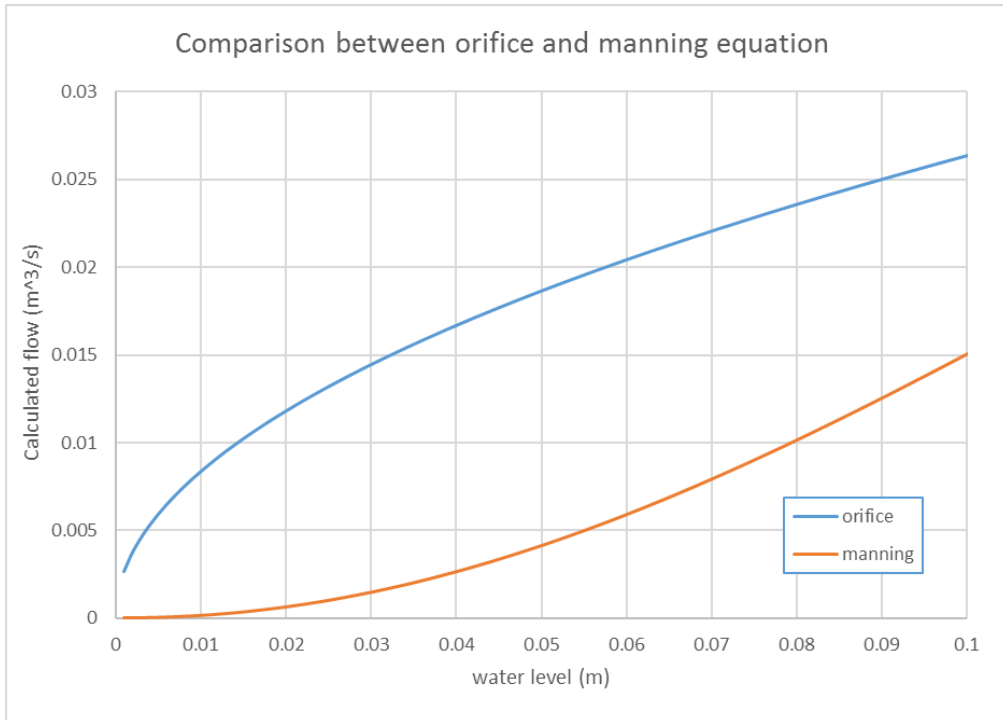

Figure 3.3. Comparison between orifice and Manning equation for rising head in a 20-cm diameter pipe. The orifice equation is applied as if the pipe is always fully submerged, i.e. the current underdrain equation in SWMM.

3.4 Developing new code

SWMM source code for edition 5.1.011 was downloaded and compiled in Visual Studio 2017. Modifications were done to the LID-processing routine and additional code was developed for managing new user input. The most notable change is additional options for underdrains in the LID-settings. Two new flow calculation methods were added as mentioned in section 3.1; orifice flow and Manning's equation. Apart from adding a more comprehensible input for the user these equations were added to stabilize output where unwanted oscillations were previously observed. Furthermore, the option of setting up the LID with a second elevated outlet was added. This elevated outlet conveys any water that rises above its invert. The new version of the underdrain flow code, found in `lidproc.c` within the SWMM engine, is presented in the appendix.

4 Case studies

Data and prepared models were provided for two test sites in North America. This section will introduce the sites as well as some issues which arose while the site researchers attempted to create a matching model in PCSWMM, a modeling software which utilizes the SWMM engine. The issues will then further be problematized with regard to related SWMM LID mechanics in order to suggest improvements. Where possible, the suggested improvements will be presented as workaround models which conceptualize the benefits of altering the LID code in SWMM.

4.1 Ursuline college

4.1.1 Site description



Figure 4.1. Overview of the Ursuline College site. Note that the scale is approximate. (Dorsey, et al., 2016).

The Ursuline College site is a 182 m² bio-retention cell belonging to the university of New Hampshire and researched by Jay Dorsey, Ryan Winston and William Hunt from May to November 2014 (Dorsey, et al., 2016). Runoff is captured from a 3600 m² adjacent parking lot with 77 % imperviousness. The LID has an underdrain with an upturned outlet to provide an IWS which reaches into the soil layer. Overflow is captured by an elevated beehive gate. All flow conveyed through the underdrain or

captured by the overflow gate is routed through a weir where flow rates are measured. Continuous measuring of water level from the bottom of the site up through the soil and including ponding are also made for the site. Rainfall data was recorded with a tipping-bucket rain gauge at the site. Data of daily potential evaporation was provided as estimates based on daily max and min temperatures. As the site allows hydraulic interaction to the native soil, a major part of the infiltration is also exfiltrated through the sides and bottom of the LID. Due to the high exfiltration rate, evaporation plays a rather minor role in the total water balance.

The Ursuline college site was constructed with the design type in Figure 2.3. The LID has a 680-mm thick layer of loamy sand including 80 mm mulch on the top. The storage layer is 550 mm thick, consisting of 150 mm filter layer underlain by 300 mm gravel. The underdrain is a 150-mm diameter perforated PVC-pipe with an outlet upturned to 600 mm above the site bottom.

4.1.2 Model descriptions

A PCSWMM-model of the site was provided by Jay Dorsey. The model of the site is depicted in Figure 4.2 and parameters are presented in Table 4.1.

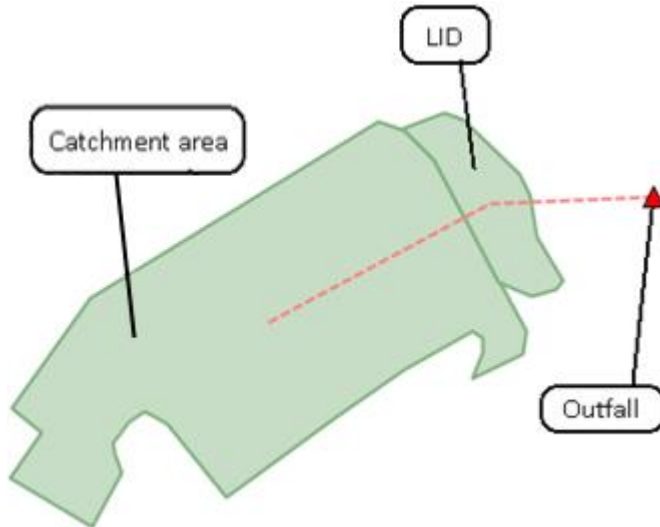

Figure 4.2. Original PCSWMM model of the Ursuline College site, developed by Jay Dorsey, Ohio Department of Natural Resources.

Table 4.1. LID parameters for the original PCSWMM model of the Ursuline College site by Jay Dorsey.

Soil layer parameters		Storage layer parameters	
Thickness (in)	27	Thickness (in)	18
Porosity (volume fraction)	0.4	Void ratio (voids/solids)	0.67
Field capacity (volume fraction)	0.15	Seepage rate (in/hr)	0.2
Wilting point (volume fraction)	0.08	Clogging factor	0
Conductivity (in/hr)	7	Drain offset height (in)	24
Conductivity slope	5		
Suction head (in)	2.4		

The recorded rainfall data was added to both the catchment area as well as the site modelled as a bio-retention cell utilizing the LID-control in SWMM. The outflow in the provided model generally matched observed flow well with a Nash-Sutcliffe value of 0.744. Major discrepancies were however observed in early event response where infiltrated water was not captured by the model. Figure 4.3 depicts how modeled inflow to the LID initially only raises the soil moisture while observations show an almost immediate response in storage level.

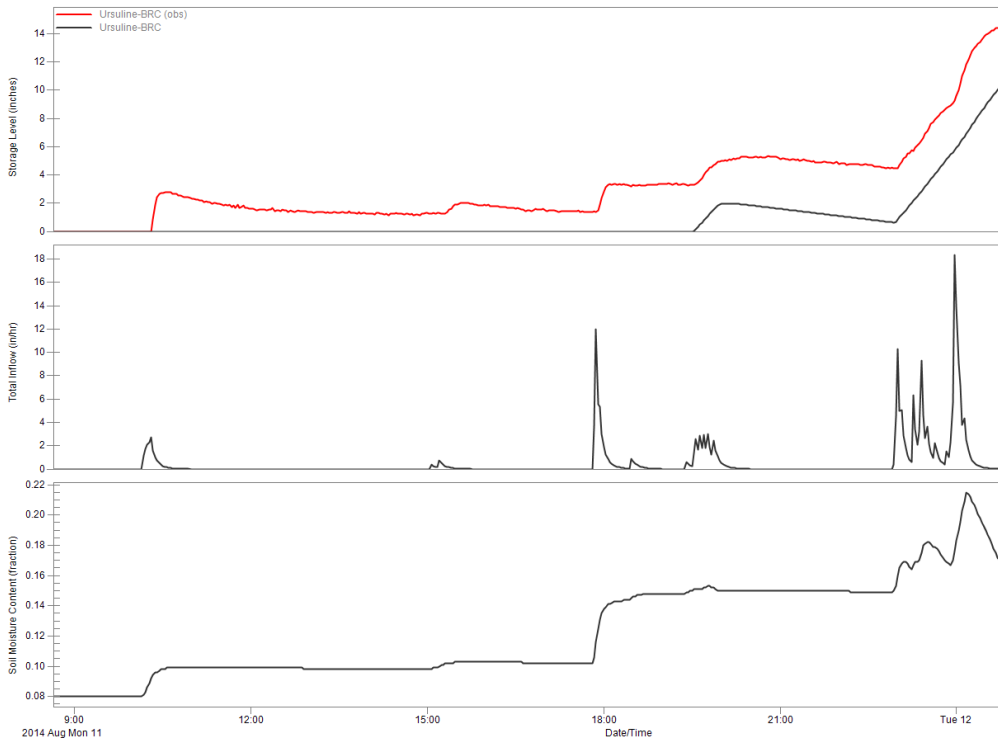

Figure 4.3. Storage water level, total inflow to the LID and soil moisture from the Original PCSWMM model of the Ursuline College site, developed by Jay Dorsey, Ohio Department of Natural Resources. Also includes in-situ measurements of the storage water level.

By comparing rainfall data to the measured water level in the gravel layer of the bio-retention cell, it becomes clear that the initial percolation rate is very high. The time lag between rainfall and rapidly rising storage levels is only 15-30 minutes. A new model, henceforth referred to as “Model 1” was therefore developed using the soil thickness as calibration parameter with the aim of recreating the actual percolation. To achieve the aim of a more accurate percolation, different settings of soil thickness was calibrated against in-situ measurements of storage level.

Additionally, a second model which will be referred to as “Model 2” was developed where the storage layer is represented separately as an infiltration trench. This representation allows for routing the LID-inflow directly to the storage layer. As the infiltration trench saturates, overflow is routed to a bio-retention cell without storage, representing the soil layer. Model 2 is therefore using the theory of a soil layer which absorbs little water until the storage layer is fully saturated. Model 2 was set up with the same parameters and measurements as the original model. Figure 4.4 depicts the site including the fictive separate storage layer, modeled as an infiltration trench.

Neither of the two new models were developed to achieve an overall improvement of modeled output but rather to showcase specific issues in SWMM and how they could be overcome.

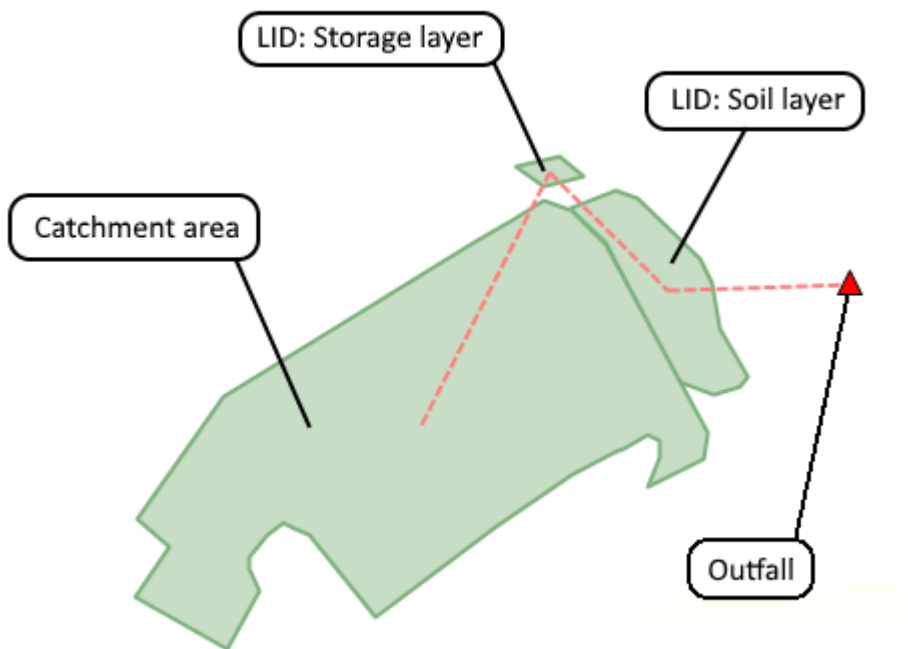

Figure 4.4. Model 2, altered version by the author of the original PCSWMM model of the Ursuline College site, developed by Jay Dorsey, Ohio Department of Natural Resources. Model 2 includes an infiltration trench labeled as “Storage layer” which run-off from the catchment area is routed to before reaching the LID for which the storage layer has been removed.

4.1.3 Model limitations

Several problems could occur in Model 1 because of having input measurements which do not correspond to the actual site. The most notable problem being when the water level rises through the soil layer. The difference in properties such as porosity and capacity to hold water will not be represented in Model 1 as much of the soil layer is characterized as gravel to get a correct percolation response.

Although measurements were made for the water level even as it reached up through the soil layer, this cannot be modeled in SWMM. Figure 4.5 shows measurements of the receding water level in the soil following a major event. A steadily reducing rate of percolation to the storage layer can be noted which follows the theory of Darcy flow. Hence, the drying phase will likely not be calculated accurately for a thoroughly wetted soil in Model 1 where the soil is represented by a soil layer much thinner than the actual site.

Model 2 was developed for accuracy in storage level response and late event percolation. However, as it uses the actual measurements of the soil layer, the issue with delayed drain flow is not addressed.

Furthermore, the settings in SWMM only allow for a constant exfiltration rate from the storage layer. In the observed measurements, the stored water recedes at varying rates over the observation period. The models could therefore not be calibrated correctly for the entire period.

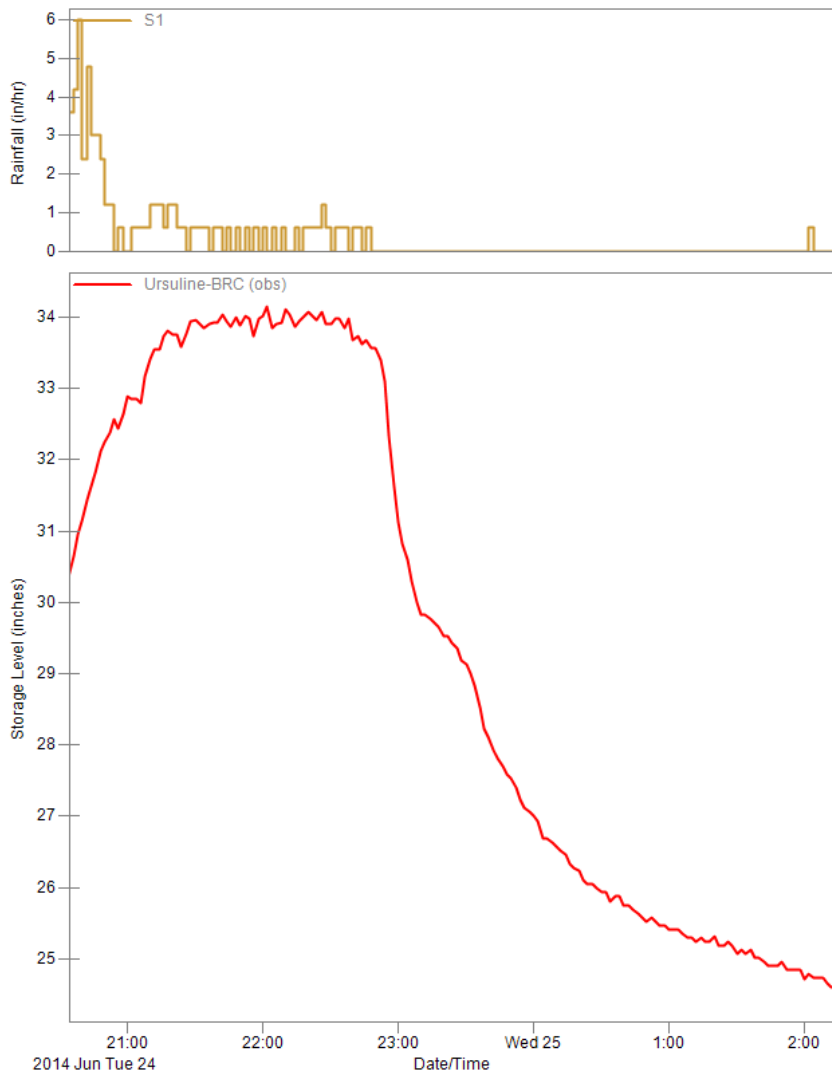

Figure 4.5. Measurements of tipping-bucket rainfall and storage water level for the Ursuline College site. The storage layer measurements show the receding water level for the phase where the water level is above the underdrain outlet located at 24 inches (61 cm) from the bottom.

4.2 Calgary

4.2.1 Site description



Figure 4.6. Calgary bio-retention site. Catchment area encircled in blue in which the LID is located in the bottom right corner. Note that the scale is approximate (Yu, 2017).

The site is a 96 m² bio-retention cell belonging to the City of Calgary in Alberta, Canada and was researched by Miao Yu over the summer of 2016 (Yu, 2017). Runoff is being captured mainly from a 2000 m² adjacent road strip seen in Figure 4.6. The captured runoff is directed to a pre-treatment sump before discharging through a monitoring flume into the bio-retention cell in the bottom right in Figure 4.6. Furthermore, all infiltrated water in the bio-retention cell is conveyed through an underdrain which discharges it into a pumping station through another monitoring flume. From the pumping station water is further pumped into a cistern. If water ponds on the surface of the bio-retention cell, an elevated beehive grate captures overflow and discharges it to the public drainage system without measuring flow.

The LID was constructed with a 450-mm thick layer of soil. The storage layer is 600 mm thick, consisting of 200 mm filter layer underlain by 400 mm gravel. The underdrain is a 200-mm diameter perforated PVC-pipe. Both the bottom and the sides of the bio-retention cell was constructed with an impermeable liner, preventing any hydrologic interaction with surrounding soil. Data of monthly potential evaporation was given as estimates from NASA.

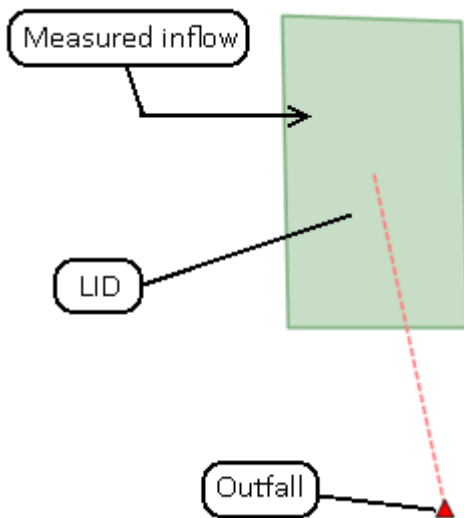

Figure 4.7. PCSWMM model of the Calgary site, developed by Miao Yu. In-situ measured inflow from the adjacent catchment area is used as input to the LID.

4.2.2 Model descriptions

As this study only focuses on the hydraulic response of the LID, the catchment area runoff response is not analysed. The same applies to the outflow where the pump station specifications are not regarded as contributing to the study. Consequently, measurements of inflow to the LID-site are used as inflow in the model, added as evenly distributed rainfall in SWMM, along with direct precipitation estimated from a rain gage. Also, the model is delimited to end with an outfall node which captures the flow out of the LID.

Yu (2017) developed a model of the site with the LID-control in SWMM. She used the physical dimensions of the site as input and calibrated it mainly by altering the saturated conductivity and conductivity slope. Final parameter settings are presented in Table 4.2.

Table 4.2. Soil parameters for the original PCSWMM Calgary model by Miao Yu.

Thickness (mm)	475
Porosity (volume fraction)	0.5
Field capacity (volume fraction)	0.2
Wilting point (volume fraction)	0.1
Conductivity (mm/hr)	225
Conductivity slope	55
Suction head (mm)	3.5

The outflow curve of the calibrated model followed measured data well for peaks where the event had recently been preceded by high inflows which saturated the soil. It did however not give an accurate outflow for the early inflows following rain events. Yu (2017) argues that the failures of the model are due to Green-Ampt's assumption of a fully wetted front while her data suggests that the soil only ever is partially wetted. Consequently, water is percolating through the soil to the storage layer after absorbing less water than Green-Ampt suggests and has less water stored to discharge as the outflow recedes. Figure 4.8 shows results of measured as well modelled outflow together with the LID inflow and modelled moisture content in the soil for a chosen period in early August. This same event will mainly be used in this report as comparison with a new model using a different modelling approach.

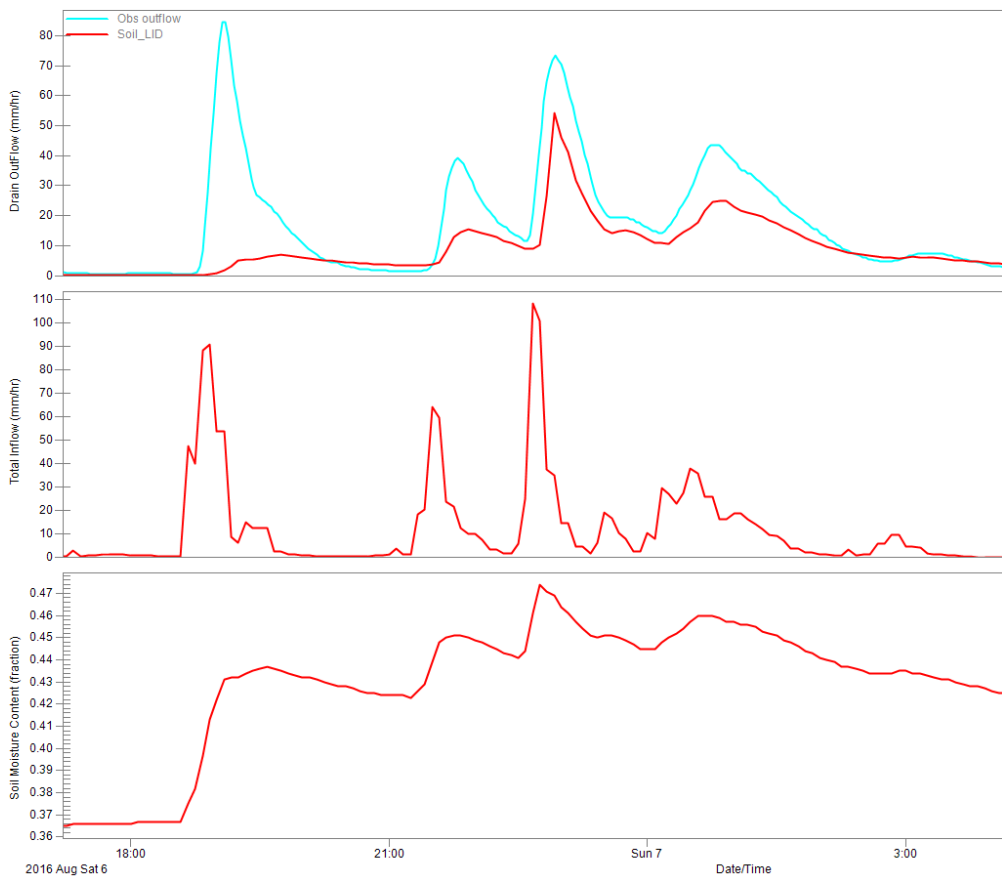

Figure 4.8. Data from the original PCSWMM Calgary model by Miao Yu. Modeled and in-situ measured drain flow for a 12-hour event in early August is presented together with inflow and soil moisture.

Unlike the Ursuline College site, the Calgary site is developed without an IWS, it also has an oversized underdrain, the water level will therefore never rise through the soil layer following saturation of the gravel layer. Assuming no evaporation from the storage layer, the thickness of the storage layer will have no impact on the results making the model accuracy solely reliant on the soil layer infiltration response.

Calibration focused on the infiltration and drain flow. Overall water balance regarding evaporation and overflow rates is assumed to not have any major impact on the interests of this study and are therefore not regarded in the calibration. Measurements from the outflow monitoring flume are instead used for calibrating the output from the model to reality.

Evaporation is assumed to only occur from the soil which leads to an unchanged water level in the storage layer in between rain events. Consequently, the storage layer properties will not be calibrated. Calibration is instead only done for parameters relating to the soil layer and underdrain.

Due to the concerns regarding assumptions of the Green-Ampt method, the calibration is mainly focusing on providing an accurate response based on measured flow data. Thus, in the new model liberties are taken with the thickness of the soil layer which will be used as a calibration parameter. This is a way to bypass the inability to capture early outflows in the original model, depicted in Figure 4.8, which was developed using the actual thickness of the soil in the test site. The conductivity slope of the soil was also used as calibration parameter.

The new model was further run with the calibrated setup but including an additional underdrain outlet according to the dual outlet approach which was suggested by Lucas (2013) and presented in section 3.1. To show the potential of this approach, the lower outlet was calibrated to the smallest possible diameter, within reasonable figures, for which the water level never rose to the top of the storage layer. A major rain event in mid-July was chosen for the purpose.

4.2.3 Model limitations

While measurements were made of the ponding level, the ponding level was also stated to vary spatially to such a degree that measurements could not be relied upon for calibration. The uncertainty regarding ponding provides difficulties in estimating the amount of overflow through the beehive gate.

5 Results

5.1 Ursuline College

5.1.1 Calibrated model fit

The thin soil in Model 1 was calibrated to 2 inches (5 cm) and produces a rapid and rather accurate storage level response compared to the original model. The Model 1 results are presented in Figure 5.1 with a red line for measured storage level, this is the same event as shown for the original model in Figure 4.3. The discrepancy in water level between 9:30 and 18:00 in Figure 5.1 could be related to inaccuracies in rain fall input as the modeled storage level is too low, despite nearly all inflow to the LID being percolated through the soil.

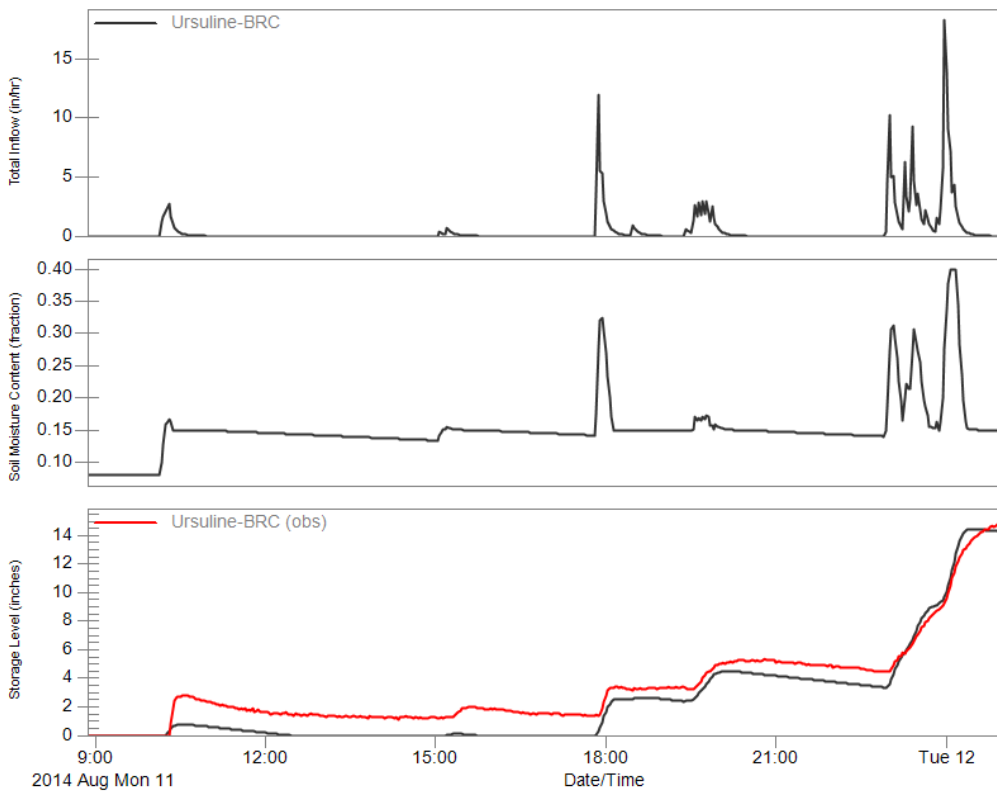

Figure 5.1. Data from the PCSWMM Model 1 for the Ursuline College site, model developed by the author. In-situ measured and modeled storage water levels are presented together with modeled soil moisture and inflow to the LID. The presented events are the same as presented in Figure 4.3 for the original model.

For Model 2, the storage level is again rather accurately modeled. The events seen in Figure 5.2 shows how the storage level repeatedly rises almost instantly in both Model 2 in black and for the measurements in red. It should be noted that the model results of the storage level only show values within the storage layer thickness. When saturated, further saturation is instead seen as spikes in the soil moisture content.

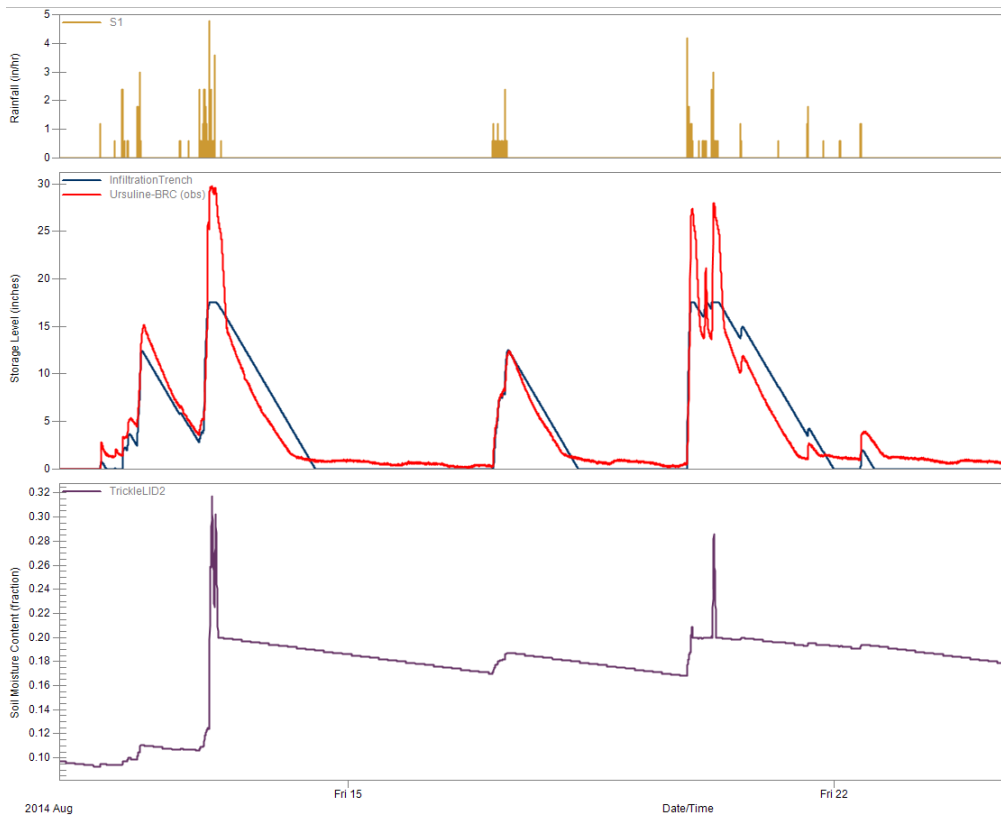

Figure 5.2. Approximately ten days of data in August from the PCSWMM Model 2 for the Ursuline College site, model developed by the author. In-situ measured and modeled storage water levels are presented together with modeled soil moisture and tipping-bucket measured rainfall to the LID.

Furthermore, Model 2 also manages well in modeling the gradual post-event drying of the soil which can be seen for an event in June, depicted in Figure 5.3. The Model 2 results of reducing soil moisture can be compared to the measured decline in storage level for the same event, shown in Figure 4.5. Calibration of Model 1 and 2 did however fail to produce a higher correlation between modeled and measured drain flow than the original model. Thus, Model 1 and 2 are not general improvements but rather an improvement of just the percolation response.

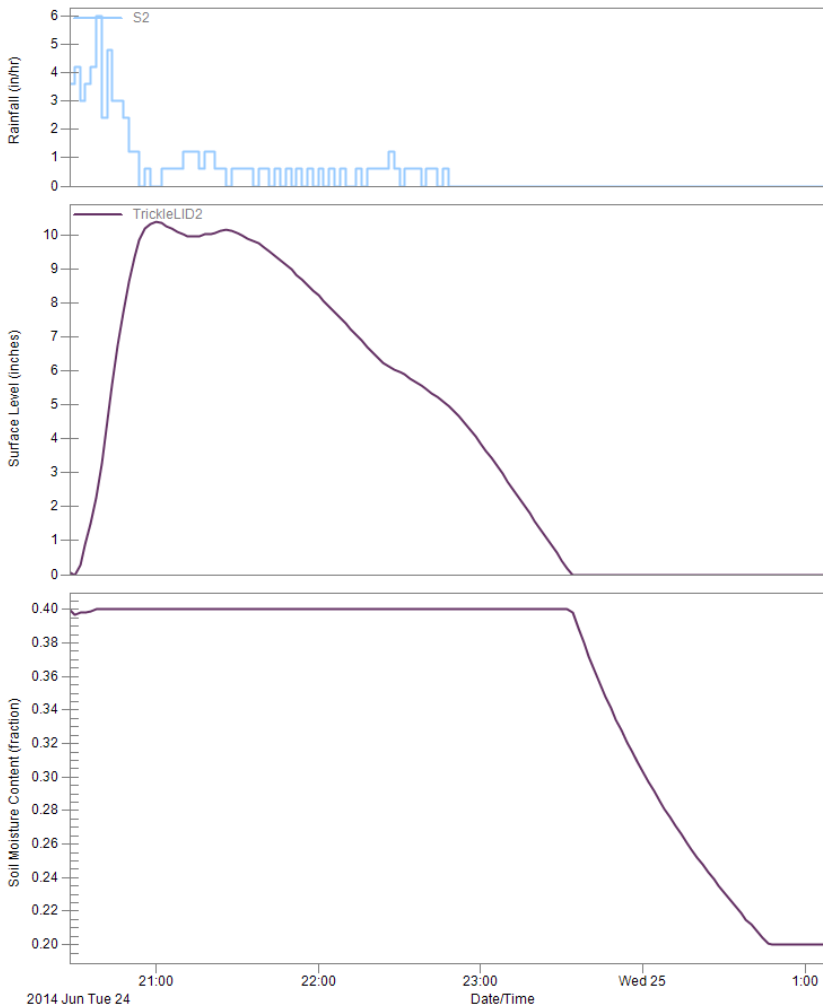

Figure 5.3. Model 2 for the Ursuline College site, model developed by the author. Modeled surface water levels are presented together with soil moisture and tipping-bucket measured rainfall to the LID. The graphs show the receding water level for the phase where the water level is above the underdrain outlet. The soil LID can be noted to drain at a reducing rate due to SWMMs assumption of Darcy percolation for drying soils. Same event as presented in Figure 4.5.

Figure 5.4 shows storage levels for Model 1 and 2 together with the original model. The lower modeled storage level for Model 2 as compared to Model 1 can be explained by the lack of direct rainfall on the LID, which is instead added to the subsequent soil layer LID.

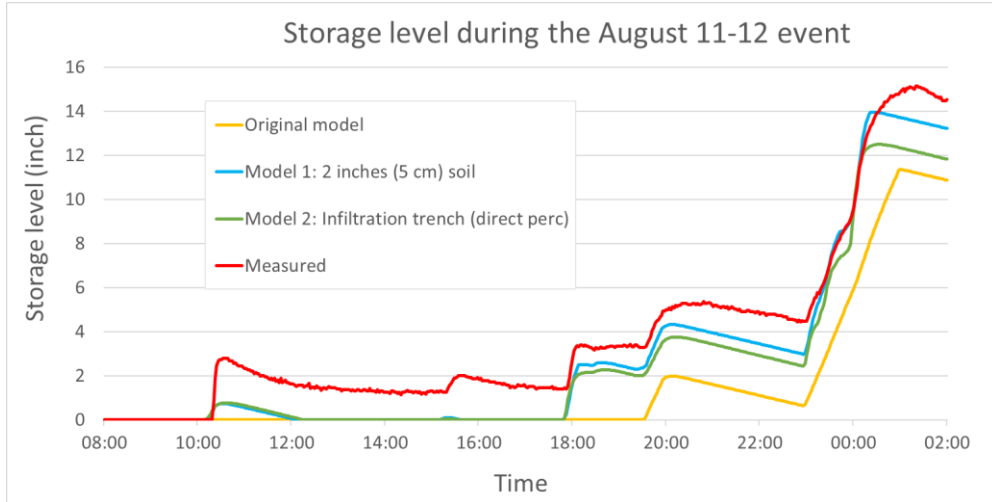

Figure 5.4. Data from the all the PCSWMM models for the Ursuline College site, Model 1 and 2 developed by the author and original by Jay Dorsey, Ohio Department of Natural Resources. In-situ measured and modeled storage water levels are presented for the same event as in Figure 4.5.

5.2 Calgary

5.2.1 Calibrated model fit

The final calibrated model had greatly reduced soil thickness of 175 mm, down from 475 mm in the real site. The conductivity slope was also reduced from 55 to 5. With these new settings, SWMM could capture early response while still responding with a high temporal accuracy. The event used in Figure 4.8 for the original model was used for new model as well, the results are presented in Figure 5.6. Oscillations appeared however, which can be related to the current underdrain equation in SWMM. As Figure 3.3 shows, the calculated flow in SWMM is relatively big for low head, i.e. when the water level is just reaching over the underdrain invert. Consequently, the modeled water level, plotted as soil moisture in Figure 5.6, tends to drop back to the underdrain invert level immediately after reaching above for one time step. Models are especially prone to oscillations when the reporting time step is smaller than the run-off time step as the run-off time step is also being used for all LID processes. Figure 5.5 shows a zoom-in of the event in Figure 5.6 where the reporting time step

is 5 minutes but run-off time step is set to 10 minutes causing SWMM to only report drain flow on the run-off iterations.

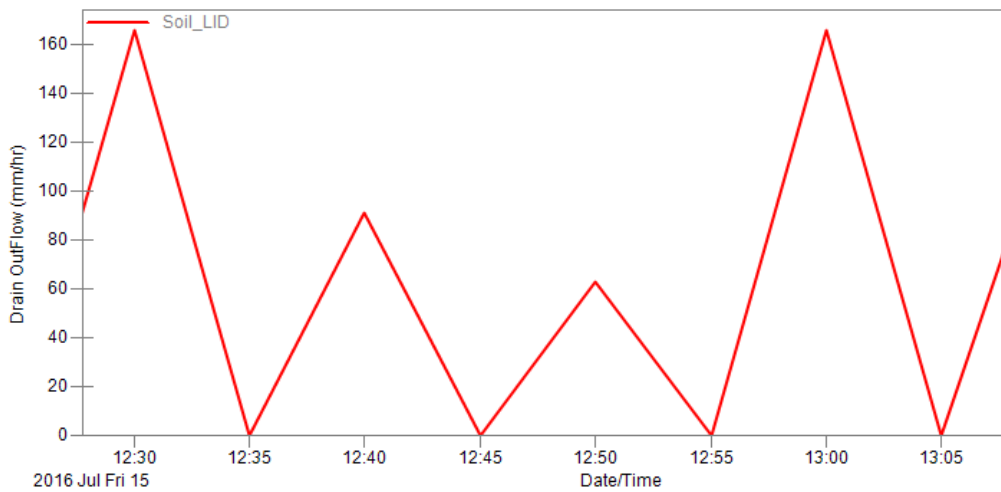

Figure 5.5. Zoom-in from Figure 5.6 of the modified PCSWMM Calgary model by the author. The graph shows how drain flow is prone to oscillate when reporting time step is lower than the one for run-off. In this model, reporting is done every 5 minutes and run-off is calculated every 10 minutes.

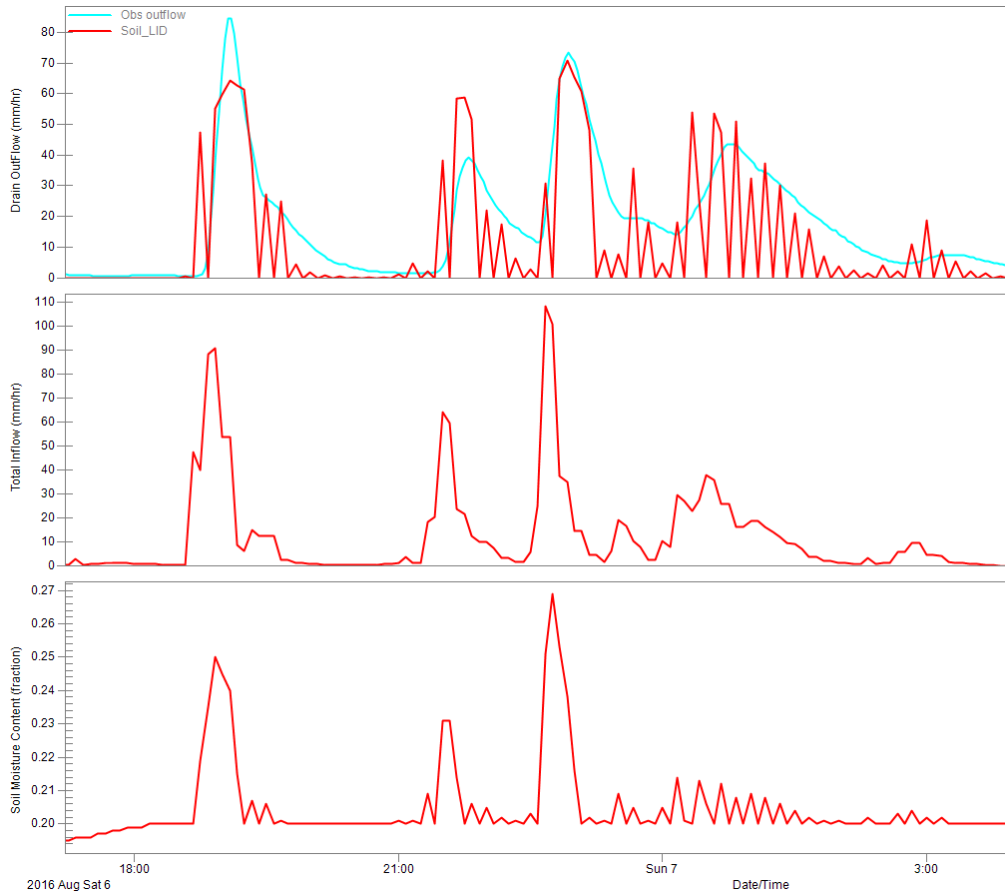

Figure 5.6. Data from the modified PCSWMM Calgary model by the author. Modeled and in-situ measured drain flow for a 12-hour event in early August is presented together with inflow and soil moisture. Soil layer thickness is lowered to 175 mm and conductivity slope to 5.

By employing the new code developed for this project, the modeled underdrain flow was greatly improved. By instead using either Manning's equation as seen in Figure 5.7 or the orifice equation as seen in Figure 5.8, SWMM produced a smoother curve. In the two figures utilizing the new code it is also easy to see how well the modelled

flow relates to measurements not despite but because of using less than half of the actual soil thickness.

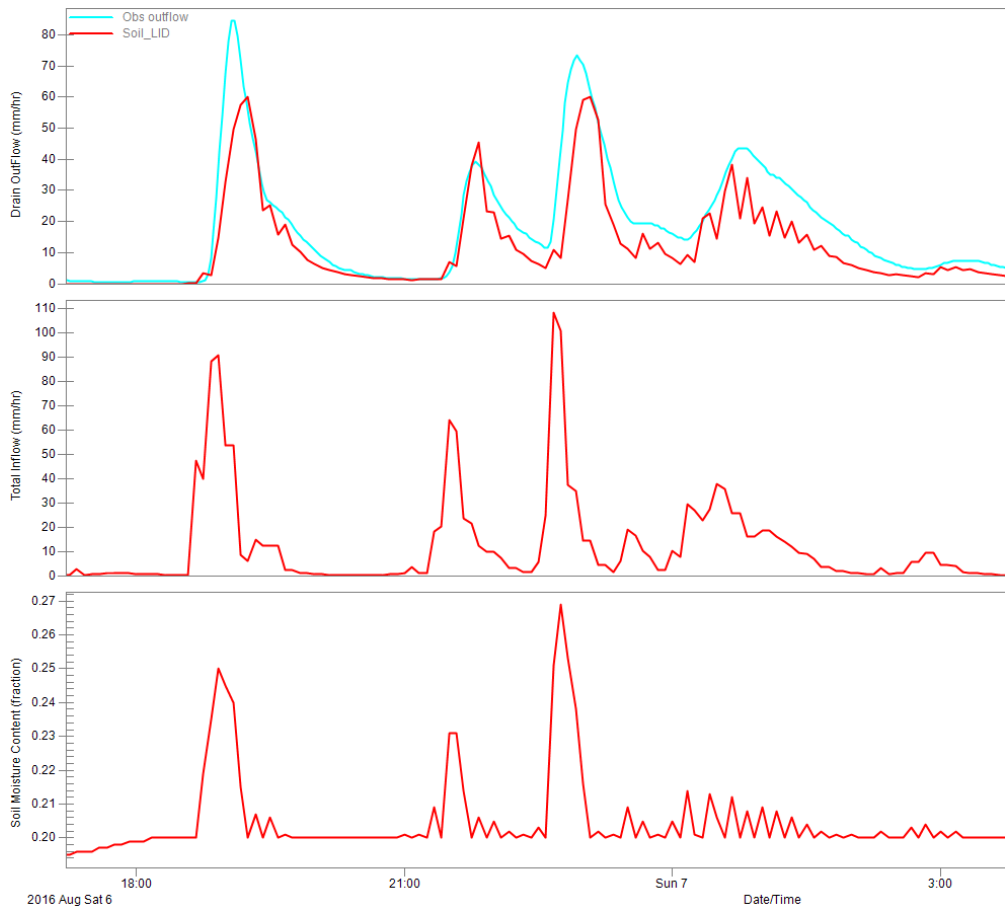

Figure 5.7. Data from the modified PCSWMM Calgary model by the author. Modeled and in-situ measured drain flow for a 12-hour event in early August is presented together with inflow and soil moisture. Soil layer thickness is lowered to 175 mm and conductivity slope to 5. Run with Manning's equation for underdrain flow with $n=0.02$ and slope = 1 %.

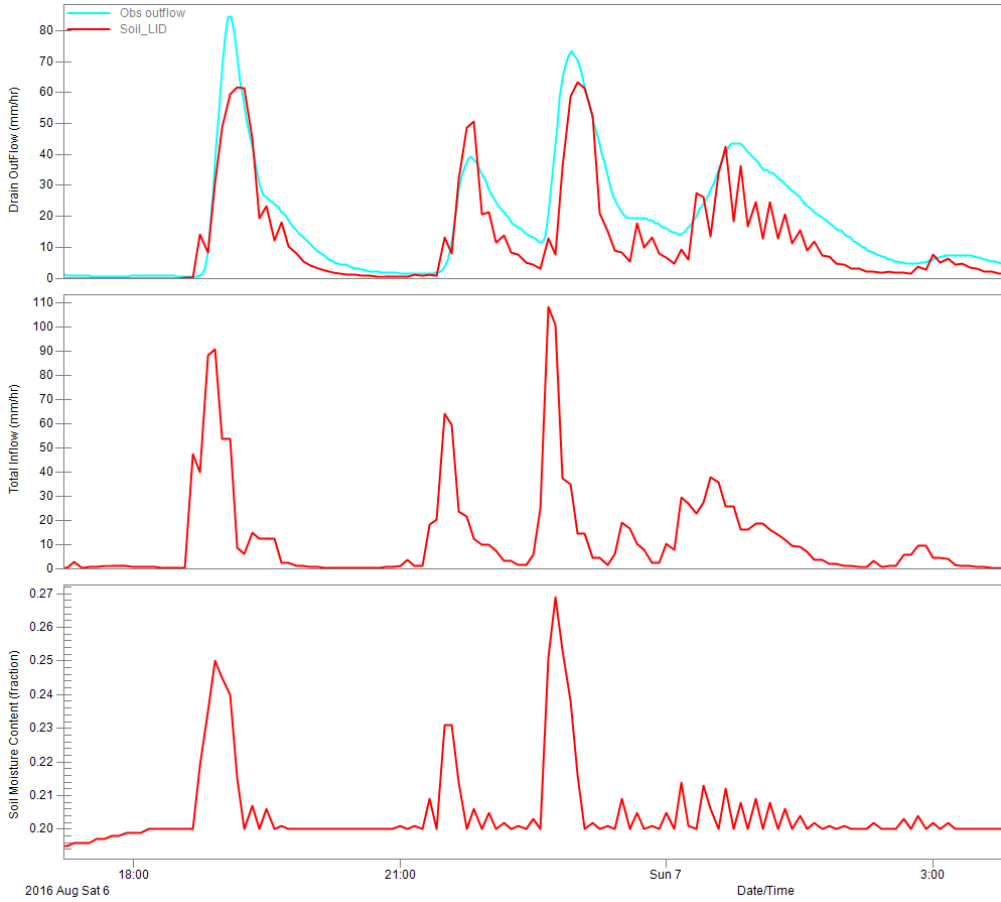

Figure 5.8. Data from the modified PCSWMM Calgary model by the author. Modeled and in-situ measured drain flow for a 12-hour event in early August is presented together with inflow and soil moisture. Soil layer thickness is lowered to 175 mm and conductivity slope to 5. Run with the partially submerged orifice equation for underdrain flow.

5.2.2 The dual outlet approach

Calibration of the model with two outlets resulted in a lower outlet with 10 mm diameter. Running the model showed promising results. For the July event in Figure 5.9, measured flow reached up to nearly 160 mm/h, hence having no actual dampening effect on the storm water network. With the small bottom outlet however, the peak flow only reaches about 10 mm/h. By greatly reducing the peak flow and detaining water in the LID, peak flows in the storm water network is reduced.

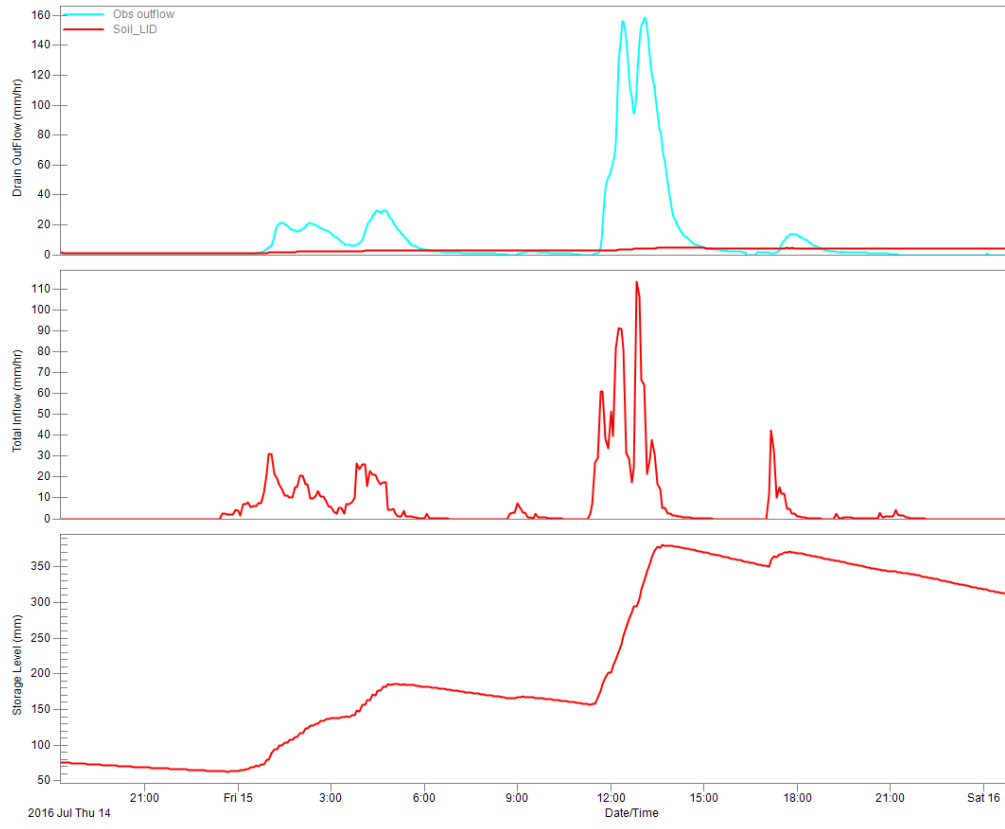

Figure 5.9. Data from the modified PCSWMM Calgary model by the author. Modeled and in-situ measured drain flow for a 12-hour event in early August is presented together with inflow and soil moisture. Soil layer thickness is lowered to 175 mm and conductivity slope to 5. Run with the dual outlet design, bottom orifice is set to 10 mm diameter.

6 Discussion and conclusion

LIDs are becoming an increasingly common practice for storm water management. There also appears to be a consensus about LID-design between US states that extends to a major European manual. However, as research progress in the field, these standards are likely to change. To facilitate subsequent implementation of new designs, it is important that tools such as computer modeling software develop alongside, or preferably ahead of, updates to construction standards. If SWMM implemented settings for promising designs under development, research would likely be moving forward at a higher pace. A comprehensive modeling environment would give researchers the tools to effectively assess and compare a small amount of in situ sites to a wider range of designs and hydrologic conditions.

Noting the rapid percolation response in water level measurements from both sites, it becomes clear that the soil does not initially saturate as the storage layer fills up. However, as the water rises through the soil, the soil saturates with water. Due to the water holding capacity of the soil the stored water should subsequently be released gradually as the water level recedes. Consequently, the delayed percolation response that follows from Green-Ampt infiltration could occur as the LID is drained after being filled up from the bottom up. Hence, different equations might be required for the initial response and the phase when the LID is drained from late event soil saturation. The Ursuline Model 2 was made to test this theory and comparing storage levels over time for model 2 and in-situ measurements builds some credibility. In Figure 4.3 the graph shows how even after a full week without rain, there is still an immediate response in storage level following the first rain event. Following the event in Figure 4.5, the soil has been fully saturated and the water level is above the underdrain outlet located at 24 inches (61 cm) from the LID-bottom. While exfiltration also occurs, the outflow can be assumed to mainly be governed by the infiltration rate. The water level can be noted to decline at a decreasing rate which follows the theory of Darcy percolation for a drying soil.

One way to get more accurate results from LID modeling could be to use or design a model that more effectively represents the hydrology in a comprehensive way. Especially, the assumption that infiltration only occurs as matrix flow should be revised. Matrix flow may be a fair assumption for some soils but as this report shows, it is clearly not always the case. One way to address the issue would be to couple matrix flow with a simplistic equation for macropore flow which could be a physically based equation or more conceptual such as the Holtan equation. While there are several benefits to developing physically based equations, the arbitrary nature of estimating infiltration might call for a conceptual model which can be calibrated by the user.

Although not thoroughly researched and never tested in this project, DRAINMOD and similar models with a more complex set of soil flow equations are likely preferable for some LID-designs. Approaches such as the one of DRAINMOD might prove especially beneficial when horizontal drain inflow cannot be neglected. This would be the case for LID-designs where the underdrain is laid in the soil. However, for most LID-designs this is not the case. In cases where the underdrain is placed in the storage layer, with or without an IWS, a simplified drain inflow approach such as the one used in SWMM appears reasonable. As the underdrain perforations cannot be accessed easily, a big risk is taken if the LID is not designed to minimize the risk of clogging around the perforations. In the case of notable clogging around the pipe, the LID could fail to achieve its intended drainage behavior in terms of drawdown time and underdrain flow capacity. An increased drawdown time could lead to prolonged ponding with associated nuisances such as odor. Furthermore, a reduced flow capacity could lead to increased overflow which increases peak flows in the storm water network and decreases water treatment.

As much of the cited research and measurements from the two test sites in this report implies, it is a difficult task to accurately model hydrology in LIDs. Even with a well calibrated model, temperature, the effect of plant growth, clogging etc. can over time be close to impossible to predict. A simple way to overcome the issue of estimating the hydrology in order to achieve design goals is to use the dual outlet design which is presented in this report. Using two outlets, a high retention can be gained also for a soil with high conductivity, chosen e.g. to allow some clogging of the soil following the time after construction. A size control on the lower outlet would enable adjustment of the drawdown time, which would create further benefits. The benefits would in part be in terms of water quality, by potentially increasing the denitrification rate in an optimized system where water is stored under anoxic conditions for a longer time. Furthermore, benefits could be gained for the storm water system in terms of quantity, as the LID would be adjustable to provide a certain retention which could reduce overall stress both from higher exfiltration, but also from reduced underdrain flow during peak hours. However, none of the major storm water modeling software are able to model flow for LIDs with two outlets. As previously argued, the lack of modeling capabilities for this promising design is likely inhibiting it from being utilized in practice.

Current models lack comprehensive setting for the LID-geometry. An LID rarely has the box type design which is used in modeling environments such as SWMM. Sloping walls and berms are examples of common features which are important settings in models to improve the accuracy of calculated volumes and water levels. Exfiltration through the walls of the unit is also unaccounted for in SWMM. Hence, the user is forced to create a model with only vertical infiltration. This could be an overly simplistic model of the hydrological interaction with the surrounding soil.

This report includes proposed SWMM code with additional underdrain flow equations. What might be the biggest advantage of allowing the proposed settings for orifice and Manning's equation is that it provides a more comprehensive input for the user. Unless designing with dual outlets, it is most often preferable to oversize the drain pipe in a way that makes it convey all infiltration. Consequently, the computational method of drain flow will not be noticed in SWMM output. Thus, the hydraulic details such as applicability of Manning's flow will often be of less importance for the modeler. The case where an outlet control is being used would however regulate the flow, making a correct estimation much more important. Factors affecting the estimation include the orifice coefficient in the suggested approach. Applying a well calibrated method for assigning head losses through the soil and outlet would further improve results and may be of yet higher importance for accurate modeling of orifice flow. As SWMM currently does not account for head losses it becomes important that the user is aware of the resulting limitations with e.g. modelling LIDs with the underdrain placed in the soil layer.

7 Suggested research

None of the software that were researched for this project had a pragmatic approach to modeling soils where infiltration follows a macropore type behavior. Hence, more research is needed on infiltration in soils such as the ones studied in this report where the assumptions of full saturation in Green-Amp does not apply.

Furthermore, research should be done of head losses for cases where LIDs have saturated soils. The research should also include the head losses for perforations in the underdrain and its underdrain where outlet controls are used.

More research on potential innovations of LIDs would improve the effectiveness and versatility of alternative solutions to storm water management. Future storm water management solutions would also benefit from research on optimization of current LID-designs to get full use of the potential hydraulic benefits in terms of retention and exfiltration.

As noted in the Ursuline site in this project, exfiltration rates can be a major factor for an LID-unit. Hence, a tool within modeling software for capturing the variability of exfiltration should be developed.

8 References

Beven, K. & Germann, P., 1982. *Macropores and Water Flow in Soils*, Charlottesville: University of Virginia.

Brown, R. A., Hunt III, W. F. & Skaggs, R. W., 2011. *Long-term modeling of bioretention hydrology with DRAINMOD*. [Online]. Available at: <https://repository.lib.ncsu.edu/bitstream/handle/1840.4/8155/NC-WRRI-415.pdf?sequence=1> [Accessed 31 January 2017].

Center for Watershed Protection, 2013. *Stormwater Management Guidebook*. [Online]. Available at: http://doee.dc.gov/sites/default/files/dc/sites/ddoe/page_content/attachments/FinalGuidebook_changes%20accepted_Chapters%201-7_07_29_2013_compressed.pdf [Accessed 10 February 2017].

CHI WATER, 2017. *US EPA SWMM*. [Online]. Available at: <https://www.pcswmm.com/Downloads/USEPASWMM> [Accessed 7 February 2017].

City of Philadelphia, 2014. *Stormwater Management Guidance Manual*. [Online] Available at: [https://www.pwdplanreview.org/upload/pdf/Full%20Manual%20\(Mannual%20Version%20202.1\).pdf](https://www.pwdplanreview.org/upload/pdf/Full%20Manual%20(Mannual%20Version%20202.1).pdf) [Accessed 10 February 2017].

Credit Valley Conservation, 2012. *Low Impact Development - Construction Guide*. [Online] Available at: <http://www.creditvalleyca.ca/wp-content/uploads/2013/03/CVC-LID-Construction-Guide-Book.pdf> [Accessed 10 February 2017].

Dorsey, D. J., Hunt, F. W. & Winston, R. J., 2016. *Quantifying volume reduction and peak flow mitigation for three bioretention cells in clay soils in northeast Ohio*, s.l.: Elsevier B.V.

Dorsey, J., 2017. *Bioretention underdrain hydraulics*. s.l.:Ohio Department of Natural Resources.

Fetter, C. W., 2001. *Applied Hydrogeology - Forth edition*, New Jersey: Prentice-Hall, Inc.

Fletcher, T. D. et al., 2014. *SUDS, LID, BMPs, WSUD and more – The evolution and application of terminology surrounding urban drainage*. [Online] Available at: <http://dx.doi.org/10.1080/1573062X.2014.916314> [Accessed 6 February 2016].

Gloucester City Council, 2013. *Sustainable Drainage - A design and Adoption Guide*. [Online] Available at: <https://www.google.ca/url?sa=t&rct=j&q=&esrc=s&source=web&cd=1&cad=rja&uact=8&ved=0ahUKEwjotbHR64XSAhXG1IMKHdWd5MQFggfMAA&url=http%3A%2F%2Fwww.gloucester.gov.uk%2Fresident%2FDocuments%2FPlanning%2520and%2520Building%2520Control%2FSUDS%2520for%2520GCC%252> [Accessed 10 February 2017].

Guo, J. C. Y. & Luu, T. M., 2015. *Operation of Cap Orifice in a Rain Garden*, s.l.: American Society of Civil Engineers.

Hunt, W. F., Skaggs, R. W. & Brown, A. R., 2013. *Calibration and validation of DRAINMOD to model bioretention hydrology*. [Online] Available at: <http://www.sciencedirect.com/science/article/pii/S0022169413001297> [Accessed 6 February 2017].

Lucas, W. C., 2013. *Interactions of Hydraulics and Biogeochemistry Involved in Nutrient Retention by Bioretention Mesocosms*, South East Queensland: Griffith University.

Lucas, W. C. & Sample, D. J., 2014. *Reducing combined sewer overflows by using outlet controls for Green Stormwater Infrastructure: Case study in Richmond, Virginia*, s.l.: Elsevier.

MacKenzie, K. A., 2015. *Estimating Flow through a Partially Submerged Vertical Orifice*, Denver, USA: Urban Drainage and Flood Control District.

Maidment, D. R., 1993. *Handbook of Hydrology*, Austin: McGraw-Hill, Inc.

Malmö Stad, 2008. *Dagvattenstrategi för Malmö*. [Online]. Available at: https://www.vasyd.se/~media/Documents/Broschyrrer/Vatten%20och%20avlopp/Dagvatten/Dagvattenstrategi_2008.ashx [Accessed February 2017].

McCutcheon, M. & Wride, D., 2013. *Shades of Green: Using SWMM LID Controls to Simulate Green Infrastructure*. [Online]. Available at: <https://www.chijournal.org/Journals/PDF/R246-15> [Accessed 6 February 2017].

Mohammadzadeh-Habili, J. & Mostafazadeh-Fard, B., 2009. *Hydraulic calculation of field drain pipe diameter: Using the theory of spatially varied flow with increasing discharge*, Isfahan, Iran: Isfahan University of Technology.

Morel-Seytoux, H. J. & Khanji, J., 1975. *Derivation of an equation of infiltration*, s.l.: Hydrological Sciences Bulletin, 20:4.

New York State, 2015. *Stormwater Management Design Manual*. [Online] Available at: http://www.dec.ny.gov/docs/water_pdf/swdm2015entire.pdf [Accessed January 2017].

PV & Associates, 2015. *WinSLAMM Model Algorithms*. [Online]. Available at: <http://winslamm.com/docs/WinSLAMM%20Model%20Algorithms%20v6.pdf> [Accessed 30 January 2017].

Rossman, L. A. & Huber, W. C., 2016a. *Storm Water Management Model Reference Manual Volume I*. [Online] Available at: <https://nepis.epa.gov/Exe/ZyPDF.cgi?Dockey=P100NYRA.txt> [Accessed 6 February 2017].

Rossman, L. A. & Huber, W. C., 2016b. *Storm Water Management Model Reference Manual Volume III – Water Quality*. [Online] Available at: <https://nepis.epa.gov/Exe/ZyPDF.cgi/P100P2NY.PDF?Dockey=P100P2NY.PDF> [Accessed January 2017].

Skaggs, R. W., 1980. *DRAINMOD Reference Report chapter 2*. [Online] Available at: https://www.bae.ncsu.edu/soil_water/documents/drainmod/chapter2.pdf [Accessed 31 January 2017].

Smolek, A. P., Winston, R. J., Dorsey, J. D. & Hunt, W. F., 2015. *Modeling the Hydrologic Performance of Bioretention and Permeable Pavement Stormwater Controls in Northern Ohio using DRAINMOD: Calibration, Validation, Sensitivity Analysis, and Future Climate Scenarios*. [Online] Available at: http://crwp.org/files/DRAINMOD_OH_ModelingReport2015.pdf [Accessed 5 February 2017].

US EPA, 2012. *Terminology of Low Impact Development*. [Online] Available at: <https://www.epa.gov/sites/production/files/2015-09/documents/bbfs2terms.pdf> [Accessed January 2017].

Washington State University Extension, 2012. *Low Impact Development - Technical Guidance Manual for Puget Sound*. [Online] Available at: http://www.psp.wa.gov/downloads/LID/20121221_LIDmanual_FINAL_secure.pdf [Accessed 10 February 2017].

Watters, G. Z., Vennard, K. J. & Street, R. L., 1995. *Elementary Fluid Mechanics*, Hoboken, NJ: Wiley, John & Sons Inc..

Weiler, M., 2017. *Macropores and preferential flow - a love-hate relationship*, Freiburg, Germany: University of Freiburg.

Winston, R. J., 2015. *Resilience of Green Infrastructure under Extreme Conditions*. [Online]. Available at: <https://repository.lib.ncsu.edu/bitstream/handle/1840.16/10890/etd.pdf?sequence=2&isAllowed=y> [Accessed 7 February 2017].

Woods Ballard, B. et al., 2015. *The SuDS Manual*. [Online] Available at: http://www.ciria.org/Memberships/The_SuDs_Manual_C753_Chapters.aspx [Accessed 10 February 2017].

Yu, M., 2017. *Modeling and monitoring LID practices*. Toronto: MPE Engineering Ltd..

Appendix, SWMM code

```
1347     double getStorageDrainRate(double storageDepth, double soilTheta,
1348     double paveDepth, double surfaceDepth)
1349     //
1350     // Purpose: computes underdrain flow rate in a LID's storage layer.
1351     // Input:  storageDepth = depth of water in storage layer (ft)
1352     //         soilTheta   = moisture content of soil layer
1353     //         paveDepth   = effective depth of water in pavement layer (ft)
1354     //         surfaceDepth = depth of ponded water on surface layer (ft)
1355     // Output: returns flow in underdrain (ft/s)
1356     //
1357     // Note:  drain eqn. is evaluated in user's units.
1358     // Note:  head on drain is water depth in storage layer plus the
1359     //         layers above it (soil, pavement, and surface in that order)
1360     //         minus the drain outlet offset.
1361     {
1362         double headFt; //New
1363         double headDrop = 0.0; //New
1364         double headOld; //New
1365         double drainDiameterFt; //New
1366         double head = storageDepth;
1367         double outflow = 0.0;
1368         double paveThickness = theLidProc->pavement.thickness;
1369         double soilThickness = theLidProc->soil.thickness;
1370         double soilPorosity = theLidProc->soil.porosity;
1371         double soilFieldCap = theLidProc->soil.fieldCap;
1372         double storageThickness = theLidProc->storage.thickness;
1373         double drainDiameter = theLidProc->drain.diam;
1374         double drainSlope = theLidProc->drain.slope;
1375         double manningN = theLidProc->drain.n;
1376         double type = theLidProc->drain.type;
1377         double f = 0.0;
1378         double Qfull = 0.0; //New
1379         double drainCoefficient = 0.0; //New
1380         double hydRad = 0.0; //New
1381         double drainArea = 0.0; //New
1382         double flowArea = 0.0; //New
1383         double outflow2 = 0.0; //New
1384         double upperOutlet = theLidProc->drain.offset2; //New
1385         TXsect* xsect = &theLidProc->drain.xsect; //New
1386
1387         // --- storage layer is full
1388         if (storageDepth >= storageThickness)
1389         {
1390             // --- a soil layer exists
1391             if (soilThickness > 0.0)
1392             {
1393                 // --- increase head by fraction of soil layer saturated
1394                 if (soilTheta > soilFieldCap)
1395                 {
1396                     head += (soilTheta - soilFieldCap) /
```

```

1397             (soilPorosity - soilFieldCap) * soilThickness;
1398
1399             // --- soil layer is saturated, increase head by water
1400             //     depth in layer above it
1401             if (soilTheta >= soilPorosity)
1402             {
1403                 if (paveThickness > 0.0) head += paveDepth;
1404                 else head += surfaceDepth;
1405             }
1406         }
1407     }
1408
1409     // --- no soil layer so increase head by water level in pavement
1410     //     layer and possibly surface layer
1411     if (paveThickness > 0.0)
1412     {
1413         head += paveDepth;
1414         if (paveDepth >= paveThickness) head += surfaceDepth;
1415     }
1416 }
1417
1418 if (head > theLidProc->drain.offset)
1419 {
1420     // --- make head relative to lower drain offset
1421     headFt = head;
1422     headFt -= theLidProc->drain.offset;
1423     drainDiameterFt = drainDiameter;
1424
1425     //if (type = "OLD")
1426     if (type == 0) // Original SWMM
1427     {
1428         headOld = head;
1429         headOld *= UCF(RAINDEPTH);
1430         outflow = theLidProc->drain.coeff * pow(headOld, theLidProc->drain.expon);
1431         outflow /= UCF(RAINFALL);
1432         return outflow;
1433     }
1434
1435     // ----- New code -----
1436
1437     //if (type = "conduit")
1438     if (type == 1) // Manning flow
1439     {
1440         if (headFt > drainDiameterFt)
1441         {
1442             hydRad = xsect_getRofY(xsect, drainDiameterFt);
1443             flowArea = xsect_getAofY(xsect, drainDiameterFt);
1444         }
1445         else
1446         {
1447             hydRad = xsect_getRofY(xsect, headFt);
1448             flowArea = xsect_getAofY(xsect, headFt);
1449         }
1450         outflow = (1.49 / manningN) * pow(hydRad, 2. / 3) * sqrt(drainSlope);

```

```

1451     outflow *= flowArea;
1452     outflow /= theLidUnit->area;
1453     outflow *= 3600;
1454     outflow *= UCF(RAINDEPTH);
1455     outflow /= UCF(RAINFALL);
1456 }
1457 if (type == 2) // Orifice flow
1458 {
1459     drainCoefficient = 0.6*PI*0.25*pow(drainDiameterFt, 2)*sqrt(2 * GRAVITY);
1460
1461     // Get submerged ratio f and fully submerged flow
1462     f = headFt / drainDiameterFt;
1463     Qfull = drainCoefficient*sqrt(drainDiameterFt);
1464
1465     if (f < 1) // case where inlet depth is below critical depth orifice behaves as a weir
1466     {
1467         outflow = Qfull*pow(f, 1.5);
1468     }
1469     else // case where submerged orifice flow applies
1470     {
1471         outflow = drainCoefficient*sqrt(headFt);
1472     }
1473     outflow /= theLidUnit->area;
1474     outflow *= 3600;
1475     outflow *= UCF(RAINDEPTH);
1476     outflow /= UCF(RAINFALL);
1477 }
1478 headDrop = outflow*Tstep;
1479
1480 if (upperOutlet > ZERO && (head - headDrop) > upperOutlet) // Second outlet flow
1481 {
1482     head -= upperOutlet+headDrop; //--- make head relative to upper drain offset after subtracting lower drain flow
1483     outflow2 = pow(head,1.5) / Tstep;
1484     outflow2 *= 3600;
1485     outflow2 *= UCF(RAINDEPTH);
1486     outflow2 /= UCF(RAINFALL);
1487 }
1488 outflow = outflow2 + outflow;
1489 // -----
1490 return outflow;
1491 }
1492 else
1493 {
1494     return 0; // To prevent errors in first row of output
1495 }
1496 }
1497 }
1498
1499 //=====

```