

Brösarp dairy farm

Bridging the agricultural gap





LUNDS
UNIVERSITET
Lunds Tekniska Högskola

Thesis work by Henrik Karlsson
Master In Architecture Of Advanced Architectural Design (MARK16)

Examinor: Christer Malmström
Supervisor: Bernt Nilsson

Date of presentation: 2018-05-31

Abstract

Within the globalization of the food industry lies gaps, disconnecting the consumer from the foods origins, increasing the ignorance about agriculture and where the food on the table comes from, and how it is produced. This thesis is focusing on the area of the dairy production industry, and how monopoly creates diversity between the small local farmer and the dairy giants, forcing small farms to shut down.

At the same time, this trend gets attention by the consumers, and statistics shows that the demand of locally produced organic products is increasing. People tend to start to care about the origins of the food they consume as a consequence of industrialization and globalization which evokes reactions against unsustainable production methods and bad animal care.

This thesis project thrives on this trend and explores possibilities to use the consumers interest to build a small business model that controls the full production chain, from farm-to-table. It explores possibilities to strengthen the relationship between farmers and consumers, and spreading knowledge about agriculture and dairy production with help of transparency and architecture.

The work explores how architecture can be combined with function to create an unexpected experience, far away from the ordinary expectations of a farm. It explores how to play with the border between farm and the public sphere by working with natural extension of the landscape, uniting architecture and nature to its extreme.

Content

1. INTRODUCTION		4. PROJECT DESIGN	
1.1 The gap	2	4.1 Site	24
1.2 Method	3	4.2 Design approach/Rules	25
1.3 Fighting the giants	4	4.3 Initial terrain concept	26
2. BRIEF		4.4 Typologies	27
2.1 The client	6	4.5 Underground	28
3. PROJECT THEORY		4.6 Site implementation	29
3.1 Bridging the agricultural gap	8	4.7 Farm - Overview	34
3.2 Project analysis	10	4.8 Plan - Overview	39
3.3 Business model		4.9 Entrance/Transport floor	42
3.3.1 Products	11	4.10 Cow shed	44
3.3.2 Scale	12	4.11 Dairy factory & courtyard	50
3.4 Dairy farming		4.12 Southern deck	56
3.4.1 In general	13	4.13 Farm shop & cheese cave	58
3.4.2 Flows	14	4.14 Farmers house	60
3.5 Dairy production		4.15 Pasture hotel	64
3.5.1 Fluid milk processing	15	4.16 Typologies - Intersection	67
3.5.2 Cheese processing	16	5. CONCLUSION	72
3.5.3 Ice-cream processing	17	6. REFERENCES	74
3.5.4 The art of aging	18	7. THANKS TO	76
3.6 Agriculture and architecture	19		
3.7 Landform and materiality	21		

1. Introduction

1.1 The gap

We, food consumers, are in present time in general three generations away from agriculture. The farms used to be the center of every village, but are today, one by one, forced to shut down due to a globalization of the market, low milk-prices and unsustainable employee costs. The total amount of farms decreases, and the bigger farms grows even bigger.

Industrialization and globalization of the food industry increases ignorance about agriculture, and a big part of the consumers have no idea where the food comes from and how it is produced. The farm-to-table experience gets more lost for every new generation.

At the same time, this development starts to attract consumers attention, awareness of local production and demand for organic products is increasing in the society. During the last decades, bakeries have popped up in every other city corner, and restaurants are building brands based on their use of local ingredients. Local becomes the new luxury in a global market. In modern urban projects, methods are developed for urban cultivation, and the majority of the population appreciates green cities with a stronger presens and connection to nature.

An increasing interest of consuming organic and local products is a step in the right direction, but does not necessarily bridge the ignorance gap within agriculture. This thesis project explores the possibilities to design a local farm that does not only produce local organic dairy products, but also builds relations between the product and its consumer, and educates consumers about what organic really means more then a label on the milk box.

Architecture

In order for relationships to be built, a basic premise is to bring consumers to the farm, and this is where architecture plays the leading role. The goal is to create a mood and a curiosity that can not be experienced on an ordinary farm. The architecture should maintain the natural environment and the beauty of the setting. It should enhance focus on what is important, as to let visitors experience food products sensually in its original atmosphere.

Since the farm used to be the center of the village, and also the employer for a great amount of the residents, the farm was also a very social place. Todays farms are designed and dimensioned for agricultural technology which replaces human labor, and creates spaces without human character. The proposed farm should encourage and impose social interaction, to make the farm a social place once again.

1.2 Method

The work has been divided into separate research studies about agriculture and architecture to in symbiosis develop this project. All agricultural research was baked into one topic that definies the theoretical focus point of this thesis.

- **Building relationships between consumer & product**

This focus point includes studies and research about the farm as a function and as a business; Dairy farming, dairy production, cattle raising, internal functions and flows, and how these different departments integrates with each other. It includes research about organic agriculture, local production, transparency etc.

The second focus point defines a more architectural approach, which explores architecture in its relation to context.

- **Architecture and natural integration.**

Includes studies of context inferior architecture, materials, natural climatization, land-forming, gradienting public spheres, and social space.

Together, these studies intend to improve the relationship building between product and consumer by offering a transparent business associated with a great architectural experience surrounded by nature.

Information for this thesis project was gathered online, through books and reports, but most importantly; interviews with a dairy farmer, and a local micro-dairy farmer.



1.3 Fighting the giants

“If there is gonna be any farmers left then something needs to happen. We do not manage financially, we have to get better paid for the milk. The situation is critical, I get less and less payed, and I work seven days a week, at least ten hours a day, sometimes without salary. It is a hard to force the consumers to pay more, even if they are willing to. The biggest issue is that the powerful dairy’s on the market pays me to less for the milk, while their financial state is thriving on our loss.” (Sveriges Radio, 2012)

These are the words from a Swedish milk farmer in an interview during a big manifestation in Stockholm for better milk prices. The milk pricing has been a big debate during the last decade, and statistics shows that the prices are slowly going up, thanks to the consumers will to pay more. (LRF, 2017). Still, the consumption of milk based products around the world are increasing much faster then the milk farmers salaries. Drinkable milk itself have globally got a lower demand, while the demand of fatter products like cheese and butter are increasing more then ever. The milk crisis forced a lot of small milk farms to close, which now years later, becomes a problem for the big dairy companies when the demand is increasing and fewer farmers are producing. This forces already big farms to grow even bigger and increases the load of work for the already stressed farmers.

Micro-dairy’s: A growing trend

The farmers fight against the major dairy companies has influenced small farmers to come up with alternative income solutions. More milk farmers are starting up their own micro-dairies which, in addition to better payment - also gives the opportunity for meeting between farmers and consumers. An interviewed micro-dairy farmer claims that the new business gives her new energy, and that visiting customers have no problem to pay more for the milk on the farm, then they would do in the grocery stores (LRF, 2016).

Why small-scale?

Small scale is a win for the consumer, the farmer and the environment. It satisfies the demand of local products, creates short transports and builds consumer relations by local sells.

Big dairy farms taking over the load from bankrupt small farms are still struggling financially due to lack of financial influence towards the major dairy companies. This forces a stressed production and minimal labor costs, leading to bad animal management where cows in enormous herds are stressed to produce as much milk as possible and falls behind on the need of human contact.

Small scale farming builds a stronger relationship between the farmer and their animals where they become more then just a milk producing machine. As the golden farmer rule says; happy cows produces better milk.

2. Brief

2.1 The client

The (fictive) client for this thesis work is a farmer family consisting of a farmer couple and their two children. They have been running a big successful dairy farm producing milk for the big milk industry for decades.

“We feel like we want something more. We are running a financially pretty successful business, but the motivation and energy is gone. We want to have more control over our products, and live a more sustainable life. It is easy to just feel like a link in the chain, and we have no connection at all with our consumers. The market shows that there is a big demand of local organic dairy products, and we want to make this investment as a contribution for the environment, the society and ourselves.”

“We get scared by the increased ignorance about agriculture these days. The relationship between our product and its consumers starts in the grocery store, and from our side it stops with the milk truck driver. We want to build a business that thrives on its locality with direct relationship between us and our consumers. The dairy farms terms and existence becomes more important when the consumers are aware about us. Not only by buying our products locally, but to help spreading the knowledge about agriculture and local production. Our ambition is to give our consumers children the same perception about agriculture as we were raised into.”

“We are both big enthusiasts of delicate cheese. This is our motivation, and our ambition is to produce the best hard cheese in the local world, in a modern but traditional way. Both to be sold on our farm, but also in cheese shops and restaurants. We see great opportunities to cooperate with other local producers in the area to complement each others products, like local wineries and bakeries.”

“We don’t want the ordinary farm in this new chapter, we want architecture that corresponds to its natural context and creates an experience out of the ordinary expectations of a farm, but still works functionally as a business. Great architecture to represent a great brand!”

- Client



3. Project theory

3.1 Bridging the agricultural gap

In a survey made by *The Innovation Center for U.S. Dairy*, over 1000 adult Americans were to answer where chocolate milk comes from. Surprisingly, 48% had no clue, while 7% were convinced that it is a product that could only be produced by brown cows. (Washington post, 2017).

It is critical to connect consumers with agriculture and the farm-to-table story. It is important to highlight dairy's local origins, the farmer and regional products. In addition to promoting the nutrient and health benefits of dairy foods, marketing and leveraging local positioning can provide an emotional connection for consumers.

Public farm for local food production

The proposed project resists the globalization and highlights the local positioning. It is based on a business model of a self-sustainable dairy farm that owns and controls the full production line.

Contrary the ordinary farm, which usually is a privatized link in the production chain, the proposed farm thrives on its public accessibility. Bringing visitors to the farm is as important as the production itself.

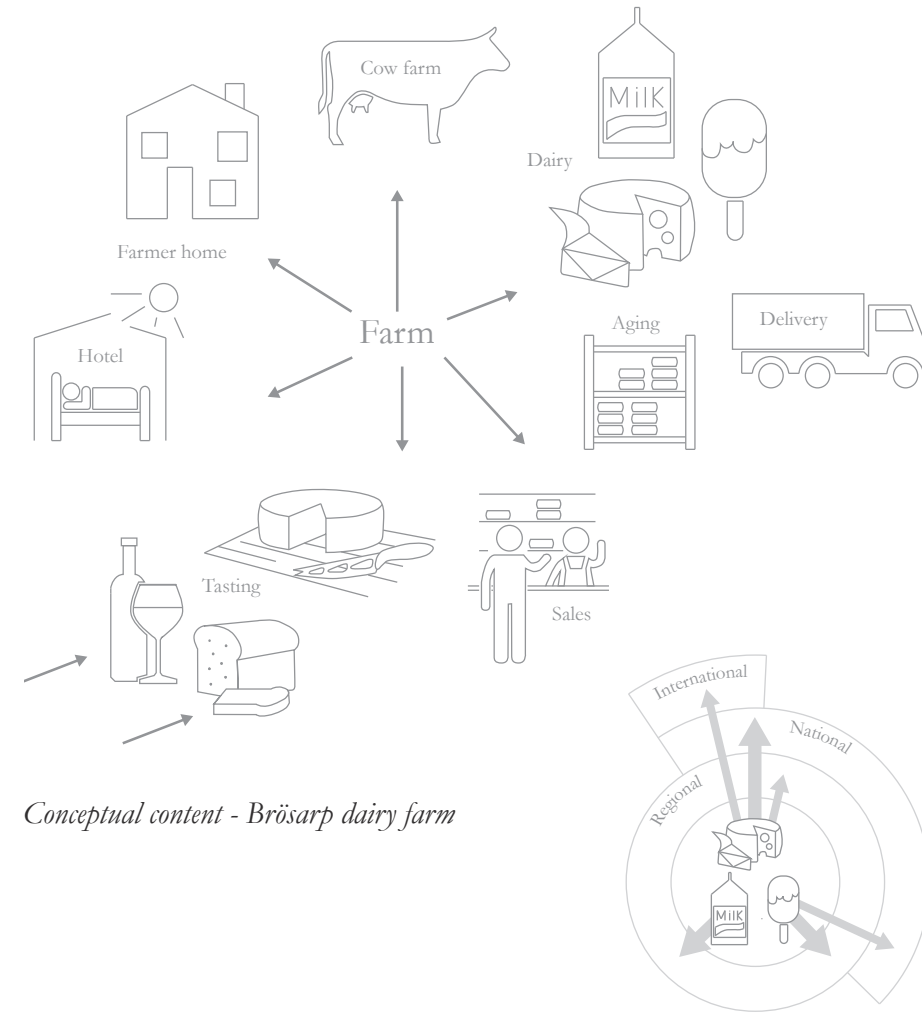

Conceptual content - Brösarp dairy farm

Market range for products

Best cheese in the local world

Genuine traditionally produced hard cheese will be the brand product for the farm. A visit offers both an internal tour of the cheese production and possibility to taste and buy the delicate cheese directly on the farm. The production will be complemented with production of processed milk and ice-cream, explained further ahead in this booklet.

Local cooperation

The farm does not only offer tasting and sells of own products, but also works in cooperation with other local farms, wineries and bakeries in the area to complement its own products and offer a full tasting experience of local food products.

What is local?

The meaning of locality in this project is not only to sell products in the local region. Locality is defined within the production; the dairy is there because the cows are there. In the same way, cows are there because the site has ideal conditions for cattle life. Local is defined in the control of the full production chain in one location, and for consumers to be able to buy products direct on the farm. In terms of market size, some products are to be sold more locally than others. Production of processed milk, and also ice-cream, is intended to be sold regionally. Delicacy hard cheese on the other hand is intended to be sold nationally, and even exported internationally if everything goes well.

An architectural farming experience

This thesis projects tries to step away from the ordinary expectations of a farm, offering an unexpected and architectonic interesting farm, based on perceived experience before rational functionalism. It becomes one with the landscape and becomes a mysterious village in the middle of the hilly rural atmosphere.

Transparency

Brösarp dairy farm works with transparency in several ways. It invites the public by gradienting the border between public landscape and farm. It offers insight into the production, and even offers over night stays with chance to get your hands dirty for real. Transparency does not only create connections, but also forces good and healthy animal care, which influences organic agriculture.

3.2 Project analysis

To understand the essence of the project, what it really is, and what qualities it should contain - a quick project brainstorm analysis was performed. It highlights critical factors that needs to be considered when developing the design.

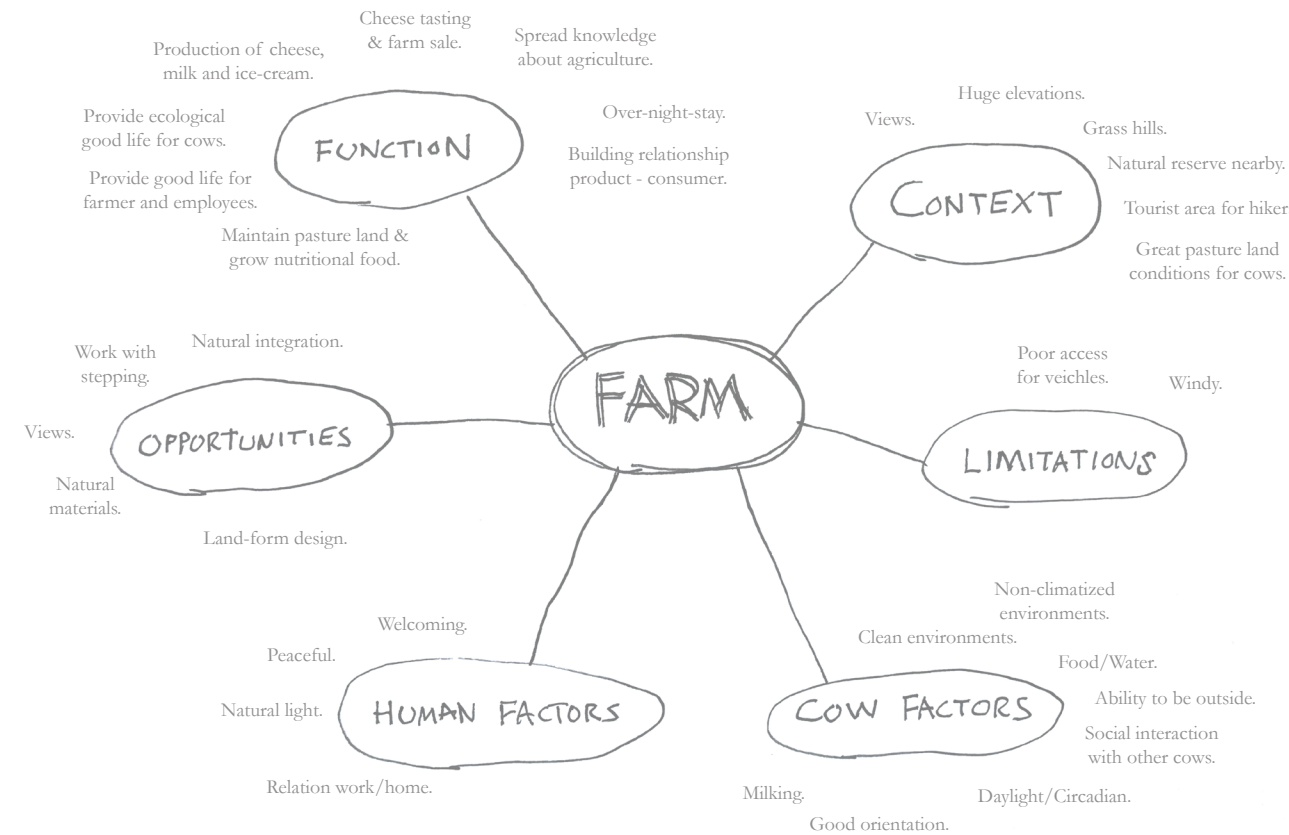

3.3 Business model

3.3.1 Products

Traditional cheese

The brand will be built on production of hard cheese, traditionally produced but with modern equipment. The cheese is made in batches every 7th day, and requires labor. Every batch requires 2250 L of raw milk to be produced over two days, which sets the number of cows needed to be able to produce that amount.

The cheese is processes and is then transported to the aging room where it will remain 3-24 months depending on the desired type of cheese.

The cheese production line can be experienced via self-guided tours, and the farm shop offers cheese tasting and sales of the cheese locally on the farm.

Organic milk

Production of organic milk is a constant but least profitable income. During periods when cheese is not produced - milk will be produced instead. The milk dairy equipment is the biggest investment, but pays back in low labor costs since it will be more or less automatic - from bulk tank to finished package. An investment in milk processing also improves the cheese, since milk is its basic ingredient.

Ice-cream

Sweden is one of the biggest consumers of ice-cream in Europe. The production is the most profitable of all the dairy products since it is mostly made out of the bi-product cream obtained from the milk separation, and has a rather high market price.

Ice-cream is a product aimed at the younger consumers, and helps bringing kids to the farm.

The production requires small amount of labor, but a lot of processing time.

3.3 Business model

3.3.2 Scale

The farms scale is determined by the scale of the business, influenced by market demands.

Cheese will be made in batches every week. The bulk tank for the batch is filled up over the weekends, and processing starts in the beginning of the new week.

The milk processing is running more or less automatically during the week days, and rests during the weekends when the cheese batch is prepared.

Ice-cream is the minor part of the production and is made in small batches seasonally, or eventually over the whole year depending on market interests.

Dairy production scale	
Expected amount of hard cheese produced/year:	10 tons (Requires 100 tons of raw milk.)
Batch size:	2250 liters of raw milk.
Batch production periods:	1 batch every 7th day.
Expected amount of milk produced/year:	300 000-350 000 liters.
Expected amount of ice-cream produced/year:	Undefined. Depends on market demands.
Cow shed scale	
Expected amount of cows:	50-60 cattles
Milking stations:	2 stations (auto)
Calv area:	<50 m2
Sick boxes:	3 boxes.
Birth boxes:	2 boxes.

Milk processing
 Cheese processing
 Ice-cream processing

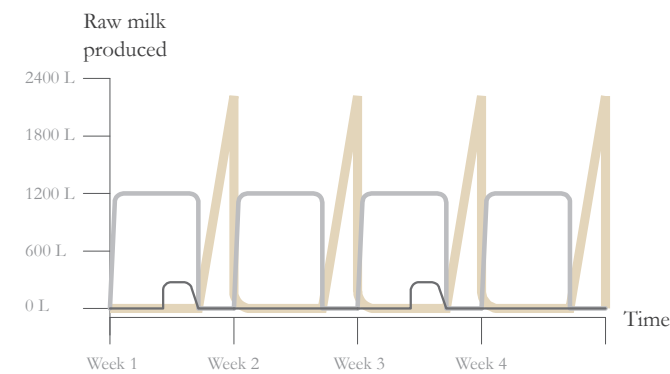

Diagram: Raw milk in production

3.4 Dairy farming

3.4.1 In general

Designing for cows

Designing for cows is very different compared to humans. The most basal needs plays a big role for their understanding and wellbeing:

- **Orientation:** A cow must be able to perceive a walkway. They need to be wide enough to not make inferior cattles feel trapped.
- **Daylight:** Is important for cattles circadian.
- **Outdoor climate:** A cattle is most comfortable in a non-climatized living environment without insulation and heating.
- **Social interaction:** With other cows and humans makes cows happy.

Life of a cow

A dairy cow is a routine animal. They like to eat, and can do it for hours. If not, they prefer to just lay down.

In order for a cow to produce milk, they need to give birth to a calf once a year. Milking is preferably done 2-3 times/day, but modern technology enables solutions where

the cows can go to a milking station to get milked whenever they feel like it.

That is simply the daily routine of a happy-dairy cow - eat, lay down, get milked... eat, lay down, get milked.

Life of a dairy farmer

In times of technology, the farmer does not need to spend much time on milking. The cows milk themselves when needed, and the task of the farmer is more about monitoring the function.

Tasks of the milk farmer includes ensuring that the animals are healthy, are well fed and gets the nutrition they need. Pregnant cows must be assisted, and the calves requires a lot of human attention.

A lot of time is spent out on the pasture land, growing, maintaining and fertilizing what will become food for the cows. Other tasks are taking care of the economy, maintaining machines, equipment and the farm buildings themselves.

Organic dairy farming

- Organic milk is produced on a farm where the cows can natural and eat the organic food they are ment to eat. They spend a lot of time on the pastures, mostly at the summers but also shorter times during the rest of the year.
- Social interaction between animals and humans is also a requirement for organic agriculture.. An organic cow gets attention.
- A calf is normally separeted from its mother directly after birth, while an organic cow gets at least one day with the calf in a calm separate area before separation. The first milk has a lot of nutrition and is important for the calfs health.
- Todays cows produces a lot of milk, sometimes up to 10 000 L/year. An organic cow produces around 8000 L/year, and lives an unstressable life.

3.4 Dairy farming

3.4.2 Flows

It is important to understand the type of flows dairy farming generates, except of physical cows moving around.

Manure

Manure is a big and crucial factor. To produce good milk the cow needs to eat a lot. This gives rise to a production of 40-55 kg of manure per cow, every day.

A shed is usually designed to take care of these loads in the walkways, where the manure is transported out to a silo with help of scraping systems on-, or under the floor.

The manure is also a valuable bi-product used as nutrition for pastures. This project intends to also use the manure for powering the farm with bio gas - a sustainable energy source.

Silage

It could be supposed that a dairy farmer spends a lot of time in the shed, but the reality is that most of the time is spent out on the pasture lands, producing food for the cows. A cow eats at least two times per day, and that requires a lot of space for silage storage during the winters.

Feeding can be done in several ways - sometimes with a tractor or similar vehicle, and sometimes with transporter belts with scrapes, a technology that preferably will be used in this project.

Milk

In this project, automatic milking stations will be used for milking. They enable the cows to get milked when they prefer, provides low labor costs, and automatically controls the health and statistics of the animals.

A milk room is connected to the milking station. Usually the milk is pumped to a raw milk tank to later be picked up by a milk truck, but since this farm has an associated dairy factory, the milk will continue directly to the dairy production line.

Other flows

Cows giving birth are moved to a separate birth area. Sick cows needs a separate sick box.

3.5 Dairy production

3.5.1 Fluid milk processing

The idea is to invest in a medium sized dairy department. The three main products are as mentioned; hard cheese, milk and seasonal ice-cream. To understand the making of cheese, we first need to understand the processing of its base ingredient - milk.

1. Raw milk

The raw milk from the cows is contained in a bulk tank. Untreated milk has a short lifespan between 1-2 days.

2. Separation

With centrifugal force, the separator separates the milk into skimmed milk (~0.01% fat) and cream (~40% fat).

3. Standardization

The fat content in raw milk varies between species and individuals. To be able to provide a consistent product, the milk is standardized. The separated cream and skim are added back to the milk in portions until the correct fat content is reached.

4. Homogenizing

The purpose of homogenization is to reduce the milk fat globules size to less than 1.0 μm which allows them to stay evenly distributed in milk (Goff, n.d). Homogenization is a high pressure process that forces milk at a high velocity through a small orifice to break up the globules. The result of homogenization is the creation of many more fat globules of a smaller size.

5. Pasteurization (HTST)

All fluid milk in Sweden is pasteurized, by heating up to milk to at least 72 degrees for about 15 seconds. These conditions provide fresh tasting milk that meets the requirements for consumer safety. Higher temperatures increases the shelf life time, but may ad unwanted flavors to the milk.

6. Filling & Packing

The processed milk in the tank is pumped to a filling station, which in this case is a fully automatic process. The packaged milk is further transported to an accumulator, a delay device to keep the transport in a continues flow. The last station, also automatic, is packing the milk boxes in carts.

7. Storage & transport

The packed carriages are temporarily stored in a walk-in-cooler waiting for transportation out on the market.

3.5 Dairy production

3.5.2 Cheese processing

Quality cheese starts with quality milk, a process that stretches all the way back to the cows on the pasture land.

Selling non-pasturized cheese in Sweden is very restricted, and can only be sold in small batches on the local farm (Livsmedelsverket, 2017). This is how cheese is made:

1. Milk processing and intake

The raw milk is, in biggest range, pasteurized before it is pumped into the cheese vat. In some cases, the milk also goes through standardization before it becomes cheese (Hill, n.d). The incoming milk is tested for quality and purity.

2. Starter culture and coagulant

Starter cultures, a good bacteria, is added to start the cheese making process. They determine the perfect flavor and texture of the cheese. Next, a milk clotting enzyme called rennet is added to coagulate the milk.

3. Cutting the batch

The batch is cut to small pieces to begin the process of separating the liquid (whey), from the milk solids (curds). Large curds are cooked at lower temperatures yielding softer cheese, like mascarpone and ricotta. Curds cut smaller are cooked at higher temperatures, yielding what this project desires; harder cheeses like parmesan and romano.

4. Stirring, heating and draining

Cheese makers cook and stir the curds and whey until the desired temperature and firmness of the curd is achieved. The whey is then drained off, leaving a tightly formed curd.

5. Curd transformation

Different handling techniques and salting affect how the curd is transformed into the many cheese varieties made.

6. Pressing

Pressing determines the characteristic shape of the cheese and helps complete the curd formation. Pressing is done by mechanical weight, hydraulic, or by the self-weight of the curd itself, as for feta. A hydraulic press will be used for this specific project. Most pressing is done during 3-12 hours, depending on the cheeses size.

7. Curing

In this case maybe the most important step. Depending on the variety and style of the cheese, it may need to cure. This is done for aged cheeses and helps to develop its flavor and texture. The aging environment needs carefully controlled required humidity and temperature. The aging process can vary from weeks to years.

3.5 Dairy production

3.5.3 Ice-cream processing

Ice-cream is a frozen mix of flavored and sweetened cream and air. Cream is gained as a rest product from the milk processing. The process is:

1. Blending the mixture

The cream, milk solids, stabilizers and emulsifiers are blended to become a complete mixture of dry and liquid ingredients (Goff, n.d).

2. Batch pasteurization

Mixture is pasteurized for a shorter or longer period of time. The process of pasteurization for ice-cream is adds more to the product compared to fluid milk because of the higher fat content.

3. Homogenization

Similar to the fluid milk process; the ice-cream is homogenized to decrease the milk fat globule size to form a smoother mix.

4. Aging

The ice-cream batch is aged at 5 degrees over night, or at least 4 hours. This process improves the whipping properties of the mix, since it cools down the mix before freezing to give protein stabilizers time to hydrate.

5. Flavors and colors

Before freezing, colors and liquid flavors can be added to the mix.

6. Freezing

Different technologies can be used for this process, but for this project we will use what is referred to as a continuous freezer. The process involves freezing the mix and incorporating air while rotating. Premium ice-creams are more dense and contains less air.

7. Packaging

The ice-cream is packaged with different methods depending on the production. Since the desired size of the farms ice-cream production is rather small, a manual filling station will be used.

8. Hardening

As quickly as possible, the ice-cream is cooled down in storage freezer to hold a temperature of less than -25 degrees. This last process freezer the small portion of water in the mix to create small ice crystals and maintain product quality.

3.5 Dairy production

3.5.4 The art of aging

An ancient cheese cave is a truly magical place with a constant ongoing silent production, where the cheese is refined and gets its final character and texture.

Cheese cave conditions

Cheese caves have been used for centuries. Due to their ability to keep cool and have a constant humidity, they become a great environment to store and age cheese. The ideal aging climate for cheese is:

- Temperature 7-14 degree C.
- Humidity of 80-98%.
- A certain amount of fresh air to remove bi-products of aging and avoid mold.

Roquefort cheese cave

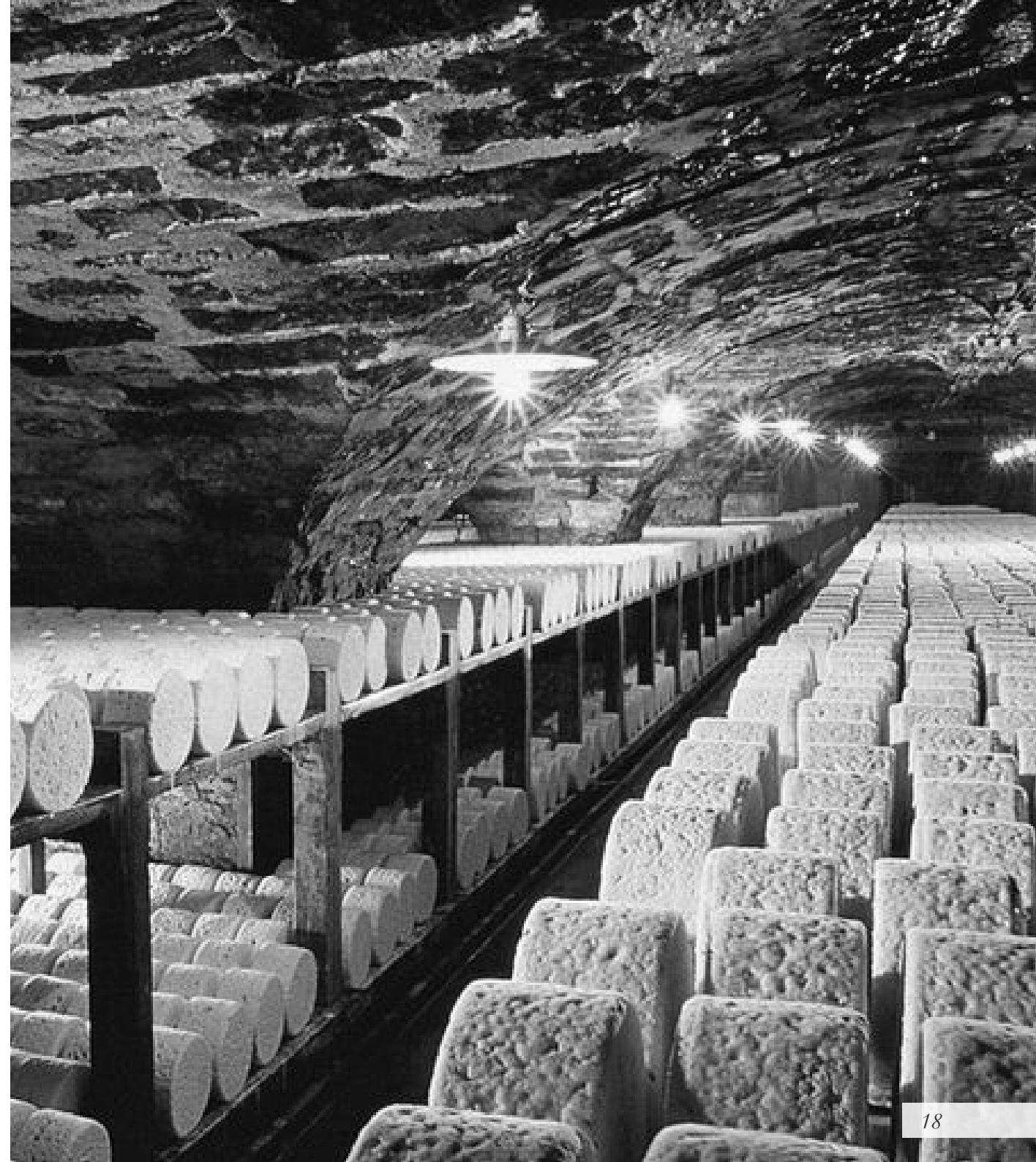

Economy building in Kvesarum, Skåne.



Torsebro Krutbruk, Skåne.



3.6 Agriculture and architecture

The fundamental thought behind the choice of doing a thesis work on farms is based in an interest of pre-industrial Skåne farms, and how they appear in their context.

Often built in heavy stones in the bottom with smaller stones further up, they become united with the ground. The buildings are often arranged in a formation of three or four links, creating a sheltered courtyard. The courtyards had a farm-functional purpose in history, but sources also reveals that the formation had a defensible aspect against unauthorized (Lange, 2008).

These pre-industrial farms have a lot of character, but unfortunately, lacks functional conditions required by todays agriculture. A lot of old farms in Sweden have sold off their land and are not anymore used for agriculture purposes. This gives rise to economy buildings just standing empty, reminding us of an ancient thriving agricultural building culture.

New built farms fulfills their function, but almost always lacks the character since they are built under rational conditions with light low-cost materials. The charm is forgotten due to function, and heavy machinery design takes away the human scale.

This project explores how heavy machinery and humans could act together by creating machine free areas and a courtyard just intended for human beings, without creating functional issues.

**Gut Garkau, Hugo Häring
Klingberg, Germany, 1924-1926**

An early international example from the modernism is Gut Garkau by Hugo Häring, built already in 1926.

Häring believed in functionalism, that form must be discovered rather than imposed, and should grow from the function of the building. The first floor of the building is made out of concrete to resist dirt and moisture, while the spectacular roof structure is completely built in timber.



Gut Garkau, Germany.



Taliesin East, Frank Lloyd Wright.



Norwegian glacier museum, Sverre Fehn.

3.7 Landform and materiality

**Taliesin East, Frank Lloyd Wright
Wisconsin, USA, 1911.**

Taliesin East was not only Frank Lloyd Wright's home and studio, but a laboratory for organic architecture. By working with irregular volumes, always inferior to the landscape, this agricultural complex becomes united with its natural context.

Sverre Fehn

"When I build on a site in nature that is totally unspoiled, it is a fight, an attack by our culture on nature, in this confrontation, I strive to make a building that will make people more aware of the beauty of the setting, and when looking at the building in the setting, a hope for a new consciousness to see the beauty there, as well"
- Sverre Fehn.

Fehn has a relevant approach to architecture which includes a big care about nature, daylight and material representation. The way Fehn mixed global theory with Norwegian regionalism is truly inspiring.



4. Project design

4.1 Site

The project site is located in the rural hilly landscape north of Brösarp in Österlen. The site is strategically picked for its hilly character, challenging inaccessibility and its proximity to Drakamöllans natural reserve, a popular tourist destination for hikers. Österlen is famous for having a strong organic food culture, with a lot of local producers, food festivals and events.

The hills are to a large extent already used as pasture land for existing farmers in the area, but also open for hikers to roam around on established trekking paths. Hiking often requires an interest in nature, which also makes hikers potential customers for the farm.

Geology

The characteristic hills are sediments from the last ice age and are mostly made out of sand and fine sand. The vegetation is out of moorland sand steppe character. Ideal excavation conditions - no dynamite required.



4.2 Design approach / Rules

The design process started by setting up a set of rules to guide the design in the true direction for the imagined experience. They create a framework for how the farm is layout-ed and relates to its context.

- **Landscape before buildings**

The project should be inferior to the landscape or supplement it considerably.



- **Natural layout**

Farms layout should be in rhythm with the natural conditions of the site.



- **Flow based layout**

Farm layout should correspond to the logic of the production flow and visitor flow.

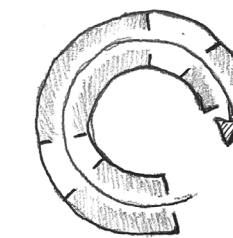

- **Horisontal excavation**

Internal spaces and courtyards are horizontal while retaining walls corresponds to the terrain.



- **Insight**

Views are everywhere on the site. The farm should prioritize insight before views - for an inner sensual cheese tasting experience.

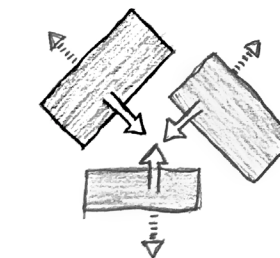

- **Blending space**

Public landscape should blend and intrude onto the farm space to create spatial gradienting, curiosity, and be inviting.

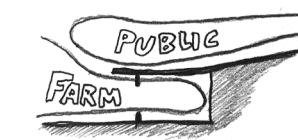

4.3 Initial terrain concept

The design rules were set in relation to the project site to find a fundamental idea for how to treat the landscape. The process led to an idea of two kinds of structures, representing different attributes.



1. Natural valley

The specific location on the site is a natural valley descending down the hilly landscape. It is a spot with great conditions for building inferior to the terrain. It forms a natural courtyard sheltered from the cold autumn winds.



2. Retaining structures

The excavated courtyard is retained with heavy super-structures, that extends the public landscape over the courtyard, and acts as shelter.



3. Lightweight structure

The courtyard is enriched with lighter and more flexible buildings, protected by the retaining structures. They are free to express a more building character, and relates more to the inner space and human scale.

4.4 Typologies

These conceptual structures developed into being defined as two major typologies:

Typology 1: Landscape

This typology is the structure that works together with the landscape. They relate to the topography and works as a superstructural extension of the landscape with help of thick green roofs which enables the public to boundlessly walk “on” the farm and invites visitors down.

Materials (main): Concrete and green roofs.

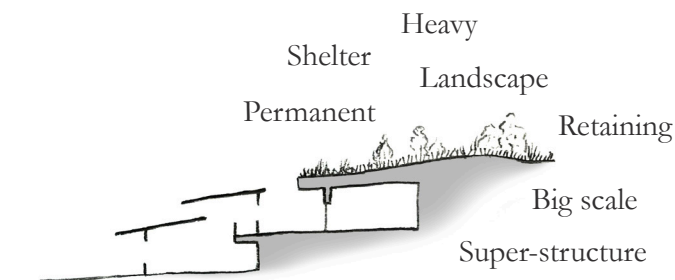

Typology 2: Building

The second typology represents what should be defined as a building. It still follows the rules of context humility, but is expressively not being a part of the landscape. The building structures are light, flexible and small scaled, and mostly represents the flow of production.

Material (main): Timber

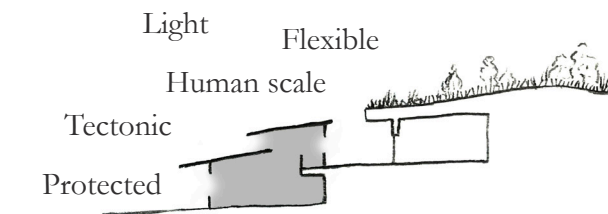

4.5 Underground

The decision to build underground is an adaption to the site context, letting the farm become inferior to the landscape. It is also an active choice based on thermal benefits to make the farm as sustainable as possible. The temperature underground is more or less constant, which keeps the interior spaces cool during the summer and keeps the heat during winter. Underground building is an ancient technique for thermal adaption especially in warmer countries. The inspiration came from traditional cheese- or wine caves, where the item can age naturally over years without technical installations.

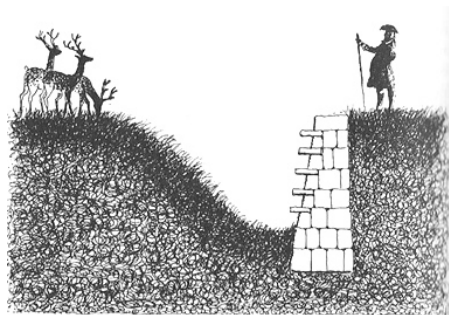

Ha-ha wall - Held unauthorized outside, without needing a visible wall.

Thermal design

The enclosing soil layer isolates the building naturally. The extension of the roof prevents the hot summer sun from entering the building, but invites the lower angled winter sun.

Natural entrances

Inspired by the “ha-ha wall”, the farm is entered by natural slopes, or grass stairs for visitors by foot.

Ha-ha light wells

The same principle as the entrances are also used as daylight wells in deep underground spots. In addition to natural light they also gives a stronger connection to the landscape above.

Natural light principle

Underground buildings all have daylight from one side. Deeper areas gets light by roof openings.

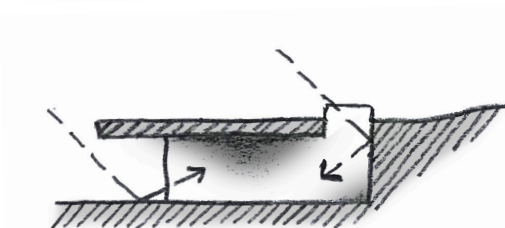
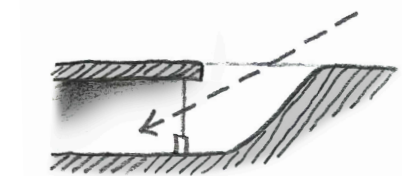
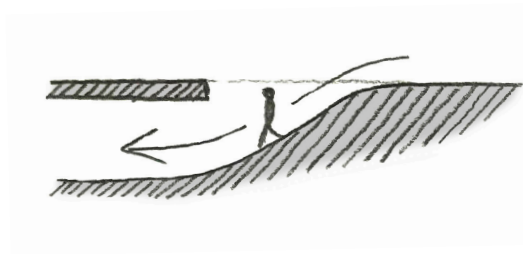
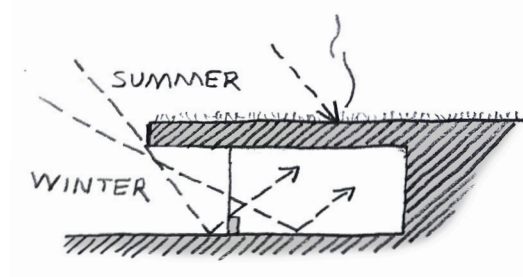

4.6 Site implementation

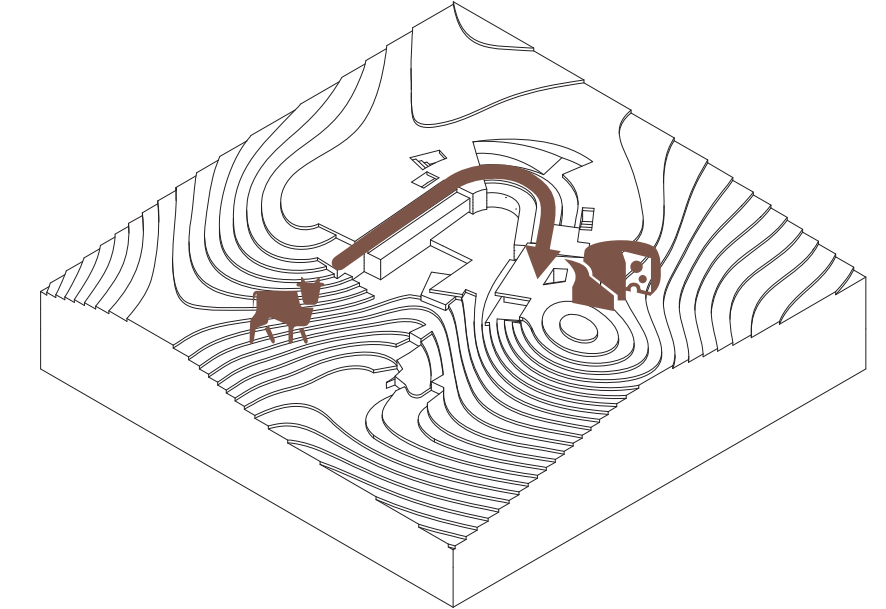
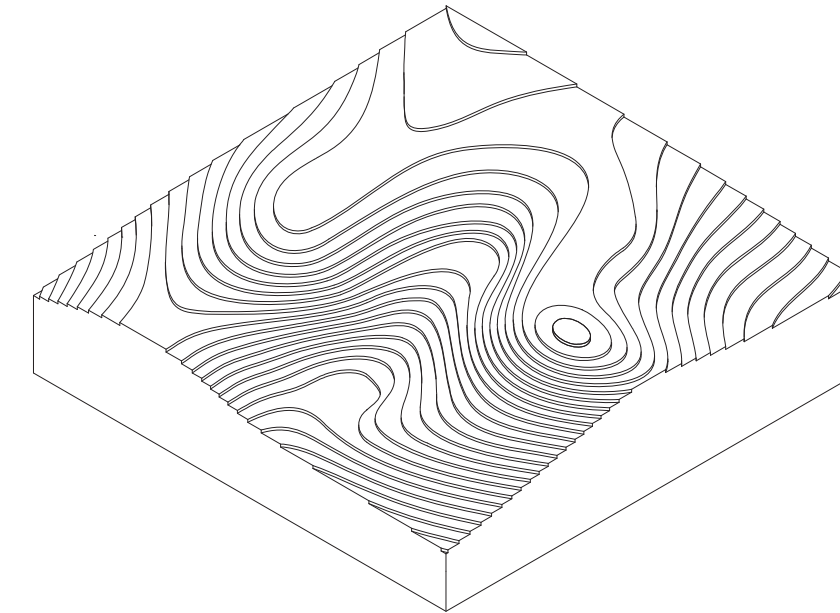

Natural conditions

These diagrams shows how the approach and ideas from the conceptual state was implemented on the actual site. The first parameter to consider for the farms layout is the natural conditions of the site. They set the basic rules.

Production flow

Building volumes follows the rhythm of the landscape, and corresponds to the logic of the production flow. Starting with the cows on the lowest level, ending with logistic transports on the top.

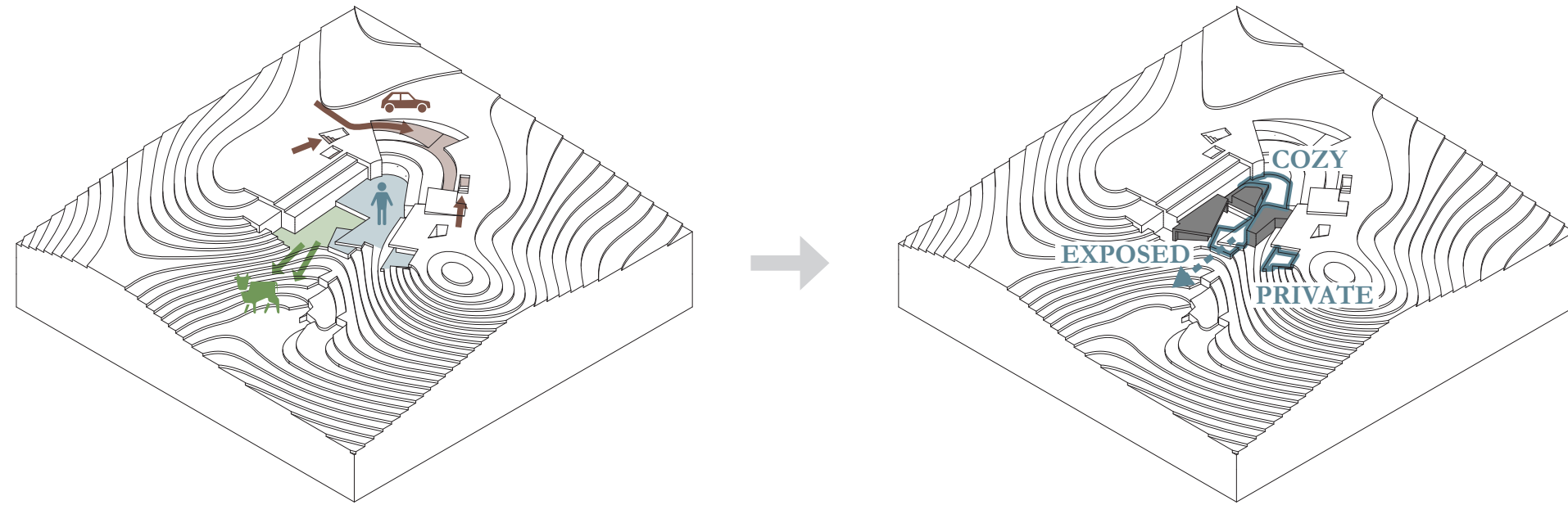

Levels & usage

Adaption to the declination of the landscape defines three different main levels for different usage. The top floor in north is defined as the logistic floor, and this is where the vehicle traffic stops. In the middle is the courtyard, intended for human use only, free from traffic. At the bottom, in direct contact with the lower landscape, is a level for cows.

Characterization

The human level is divided further by bringing in structures as fragments of the landscape onto the courtyard, dividing it into three different areas with different characters. The northern part of the courtyard becomes sheltered, introverted and calm. It connects to a more exposed view deck, which becomes the goal point for visitors. The farmers house is shielded off to create a more private outdoor space for the family.





Site plan - 1:800 (A4)

4.7 Farm - Overview

Brösarp dairy farm is gently integrated in the valley between two hill sides. Entrance by vehicle and foot is happening at the highest level towards north. The farm levels are then carefully sloping downwards in association with the valley.

Courtyard

The most central space on the farm is the courtyard. Contrary to the ordinary farms courtyard, which usually is open and empty, this specific courtyard is dedicated for humans and holds no vehicle traffic. It is intended to be an introverted, peaceful, sheltered space with human scale detailing. The courtyard is the endpoint for visitors and contains the farm shop and a viewpoint over the valley.

Production

The production spaces are arranged around the courtyard, oriented from west to east. Production spaces overlaps within both typologies, but is at the same time clearly defined in form by a light timber structure following the production flow logic.

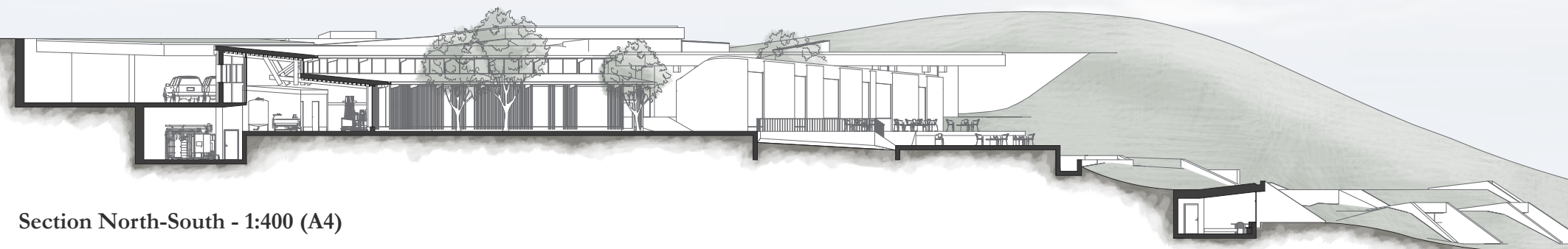

Section North-South - 1:400 (A4)

Green structures

The retaining structures follows a more unorganized layout, overlaps and blends into the landscape in different ways. These structures contains several programs, like the farmers house, loading/delivery bay, entrance hall/office and garage. Same typology is also found more centralized on the courtyard, containing staff space, farm shop and calf shed. These volumes acts as space dividers, and brings in fragments of the landscape into the courtyard.

Down the valley

From the southern view deck, the farm is naturally broken down in fragments, like a rockfall. These fragments contains the hotel rooms, and creates a gradient between the farm and the landscape.

Levels

The top level of the farm is aligned with the surface of the highest landscape. The underlaying levels are sloped down naturally with the valley to create different floors for functional separation. Transports are kept on level -1, creating a calm courtyard on level -2 for human use. The animals live on level -3, with direct connection to the bottom landscape.



Entrance

Natural tunnels brings visitors by foot down to the transport floor. The visitors choose if they want to go directly down to the courtyard, or take a de-tour to experience the dairy.

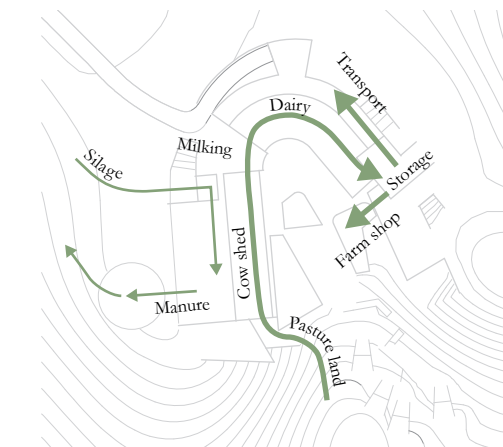

Production flow

Production starts from the bottom with the cows on the pasture land, and follows the logic of the landscape to either be transported or go to the local farm shop.



Level 0 (Landscape)
- Farm entrance

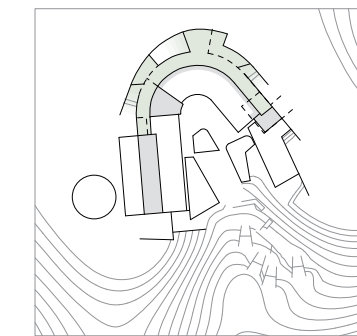

Level -1
- Transports and entrance

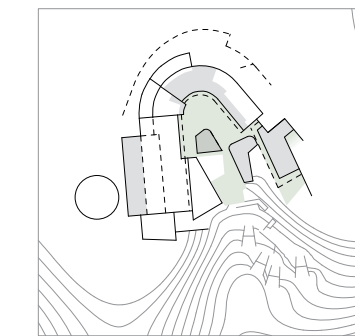

Level -2
- "Human floor"; dairy, farm shop, staff, house etc.

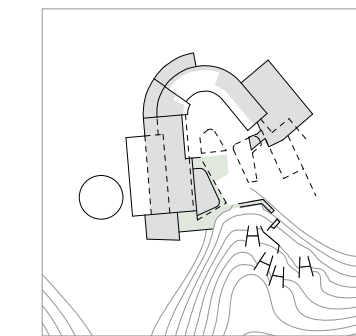

Level -3
- "Cow floor"; cow shed, garage, milking, storage, cheese cave etc.

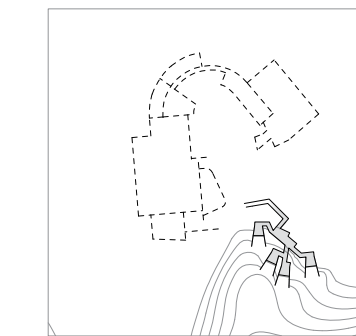

Level -4
- Hotel

Interior
Exterior

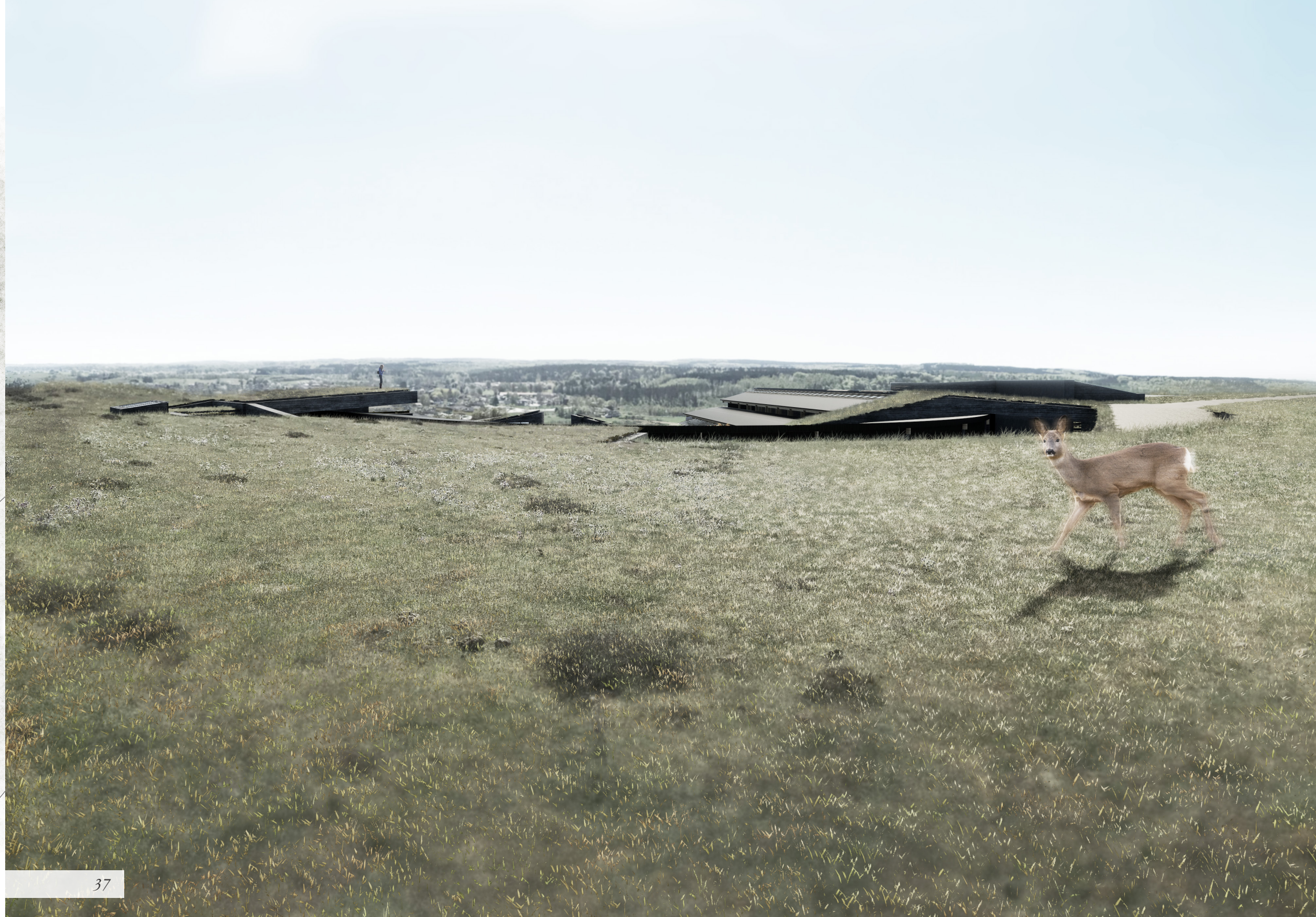
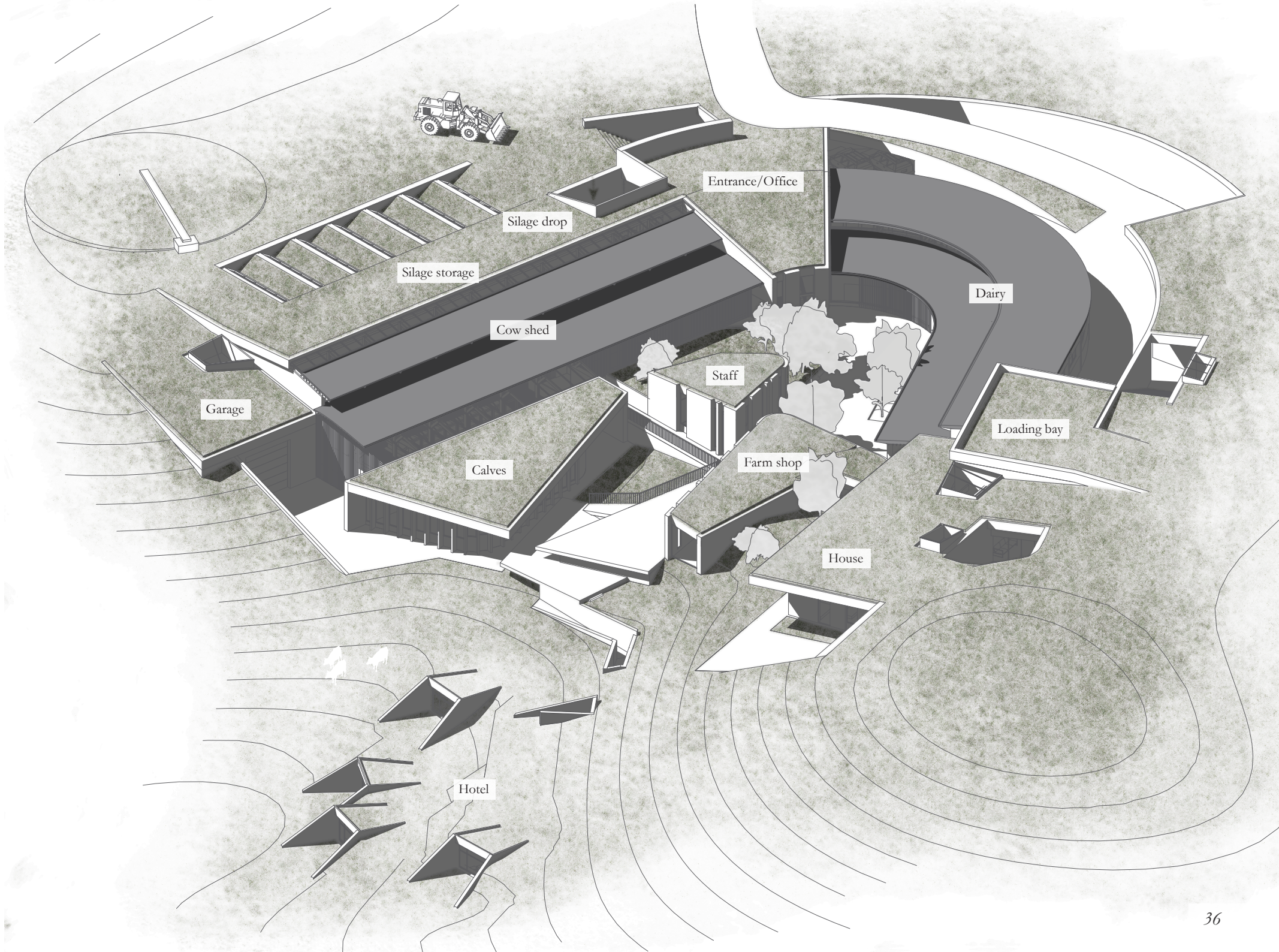

Hidden treasure

Brösarp dairy farm is lies sunken down in the valley to not be visible when walking though the hilly landscape. When approached, it suddenly starts to appear.

A romantic gesture for visitors is that the first thing they encounter when visiting the farm is the production field. The farm is approached by making your way through the pastures, regardless arrival by car or foot.



Restructural excavation

Putting the building structures in the ground requires quite a lot of landwork. Excavated ground material is relocated to even out the courtyard.

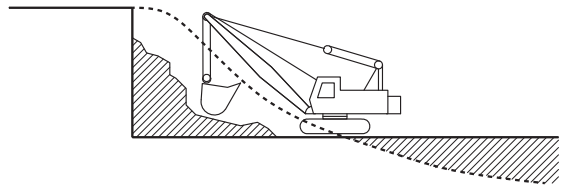

4.8 Plan - Overview

These sequence of plan drawings shows the overall plan and how it develops from the top of the landscape - to the bottom. This chapter is intended to give a clearer understanding about the farm as whole, before going into the different departments.

- First plan:** Landscape situation
- Second plan:** Logistic floor & Entrance
- Third plan:** Production

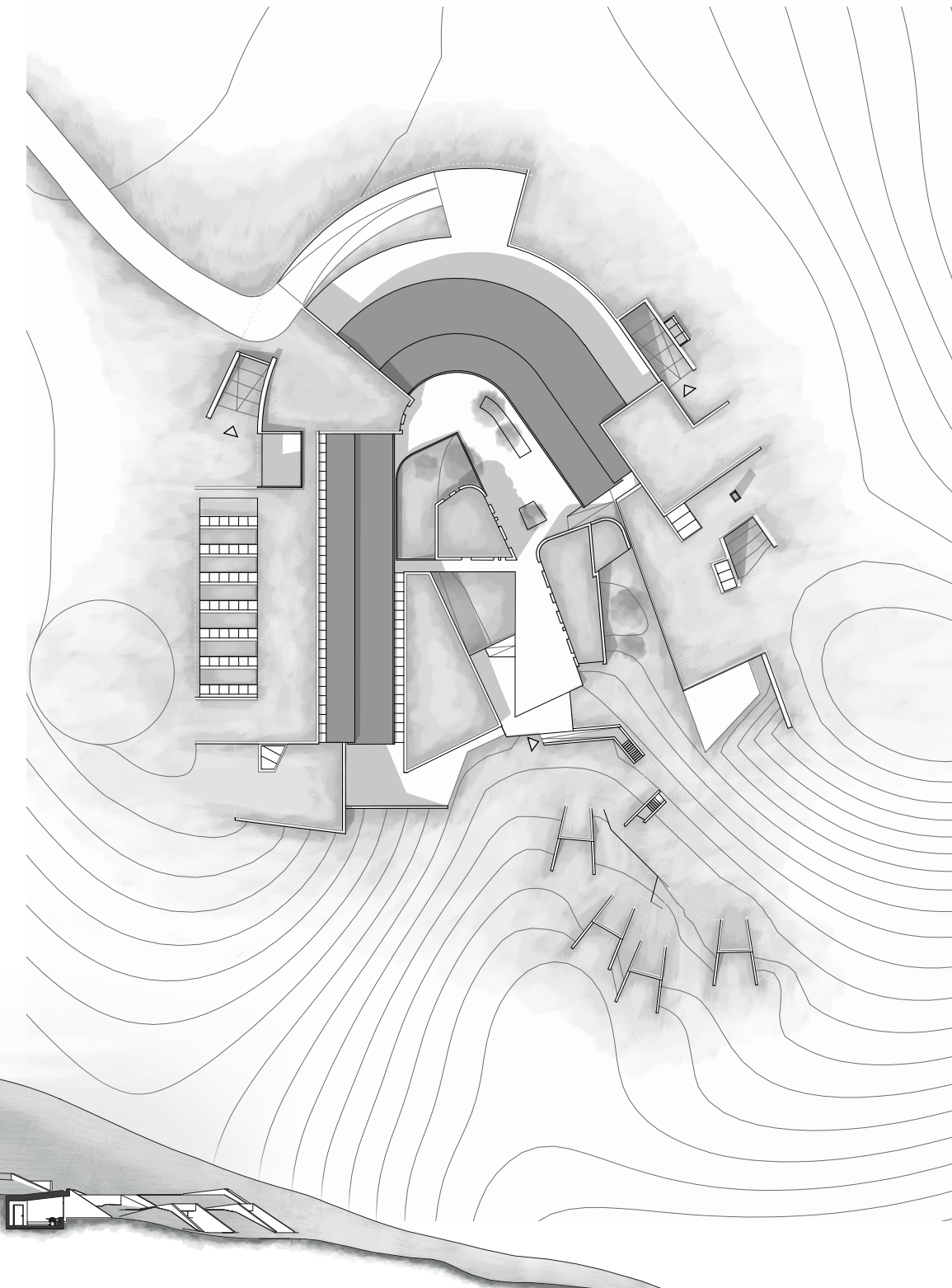

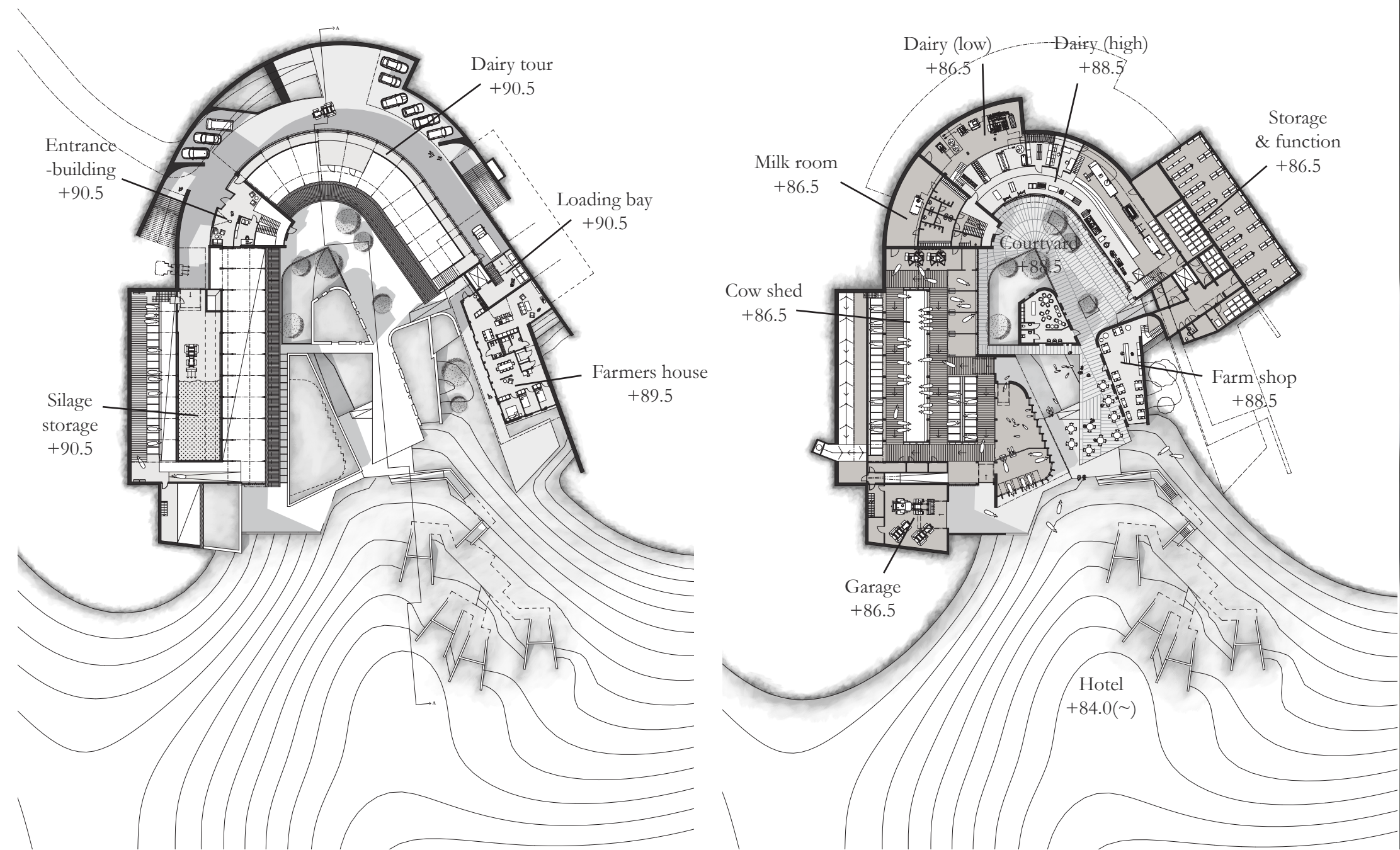

4.9 Entrance/Transport floor

Layout

The first story down from the landscape is the transportation floor. Vehicles enter by a ramp while pedestrians and hikers enter by grass-stepped entrance tunnels.

All vehicle transports stop at this floor except for farm vehicles that can make their way through the terrain. This is where visitors park their cars, and also where dairy products are loaded and transported away.

Dairy factory tour or shortcut

Closed facades and limited sight blocks the view into the dairy to force curious visitors to explore further. An entrance building allows visitors to go straight down to the courtyard, or take a self-guided tour through the dairy factory.

The foyer gives the visitors a first glimpse of the cows in the shed, and serves information about the farm and the products with help of video technology.

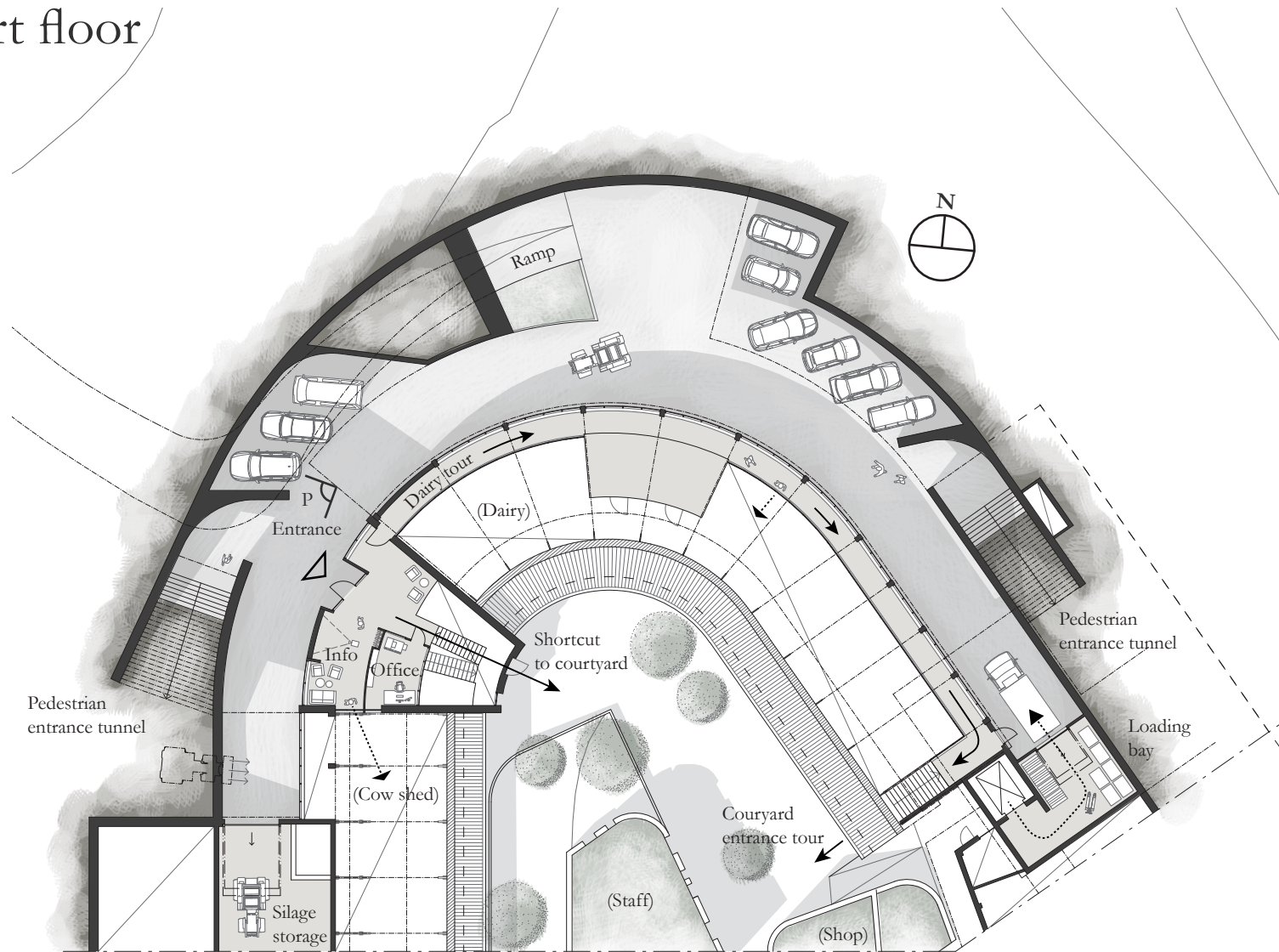

Floor plan - 1:400 (A4)



4.10 Cow shed

Layout

The stable is based on a loose housing system where the animals can move around free inside the shed. They can lay down in cow beds, but multi-boxes are also available for younger herds. Calves are kept in a separate calf area.

Milking

Two automatic milking stations are located in the north of the shed. The milk is pumped to the raw tank located in the milking room. Sick- and birth boxes are located next to the milking stations to manually assist these cows to get milked.

Food

The silage is harvested and dropped directly down to the silage storage located above the shed. The feeding is done by gravity dropping the food on the feeding table located underneath. A transport belt with scrapers spreads out an even layer.

Manure

A scraper based cleaning system under the floor cleans out the manure and transports it to the manure silo. This bi-product is used for biogas and nutrition for pastures.

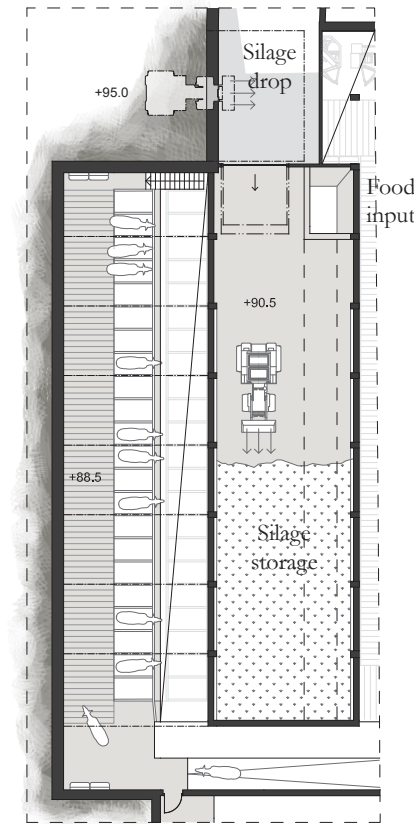

Floor above - 1:400 (A4)

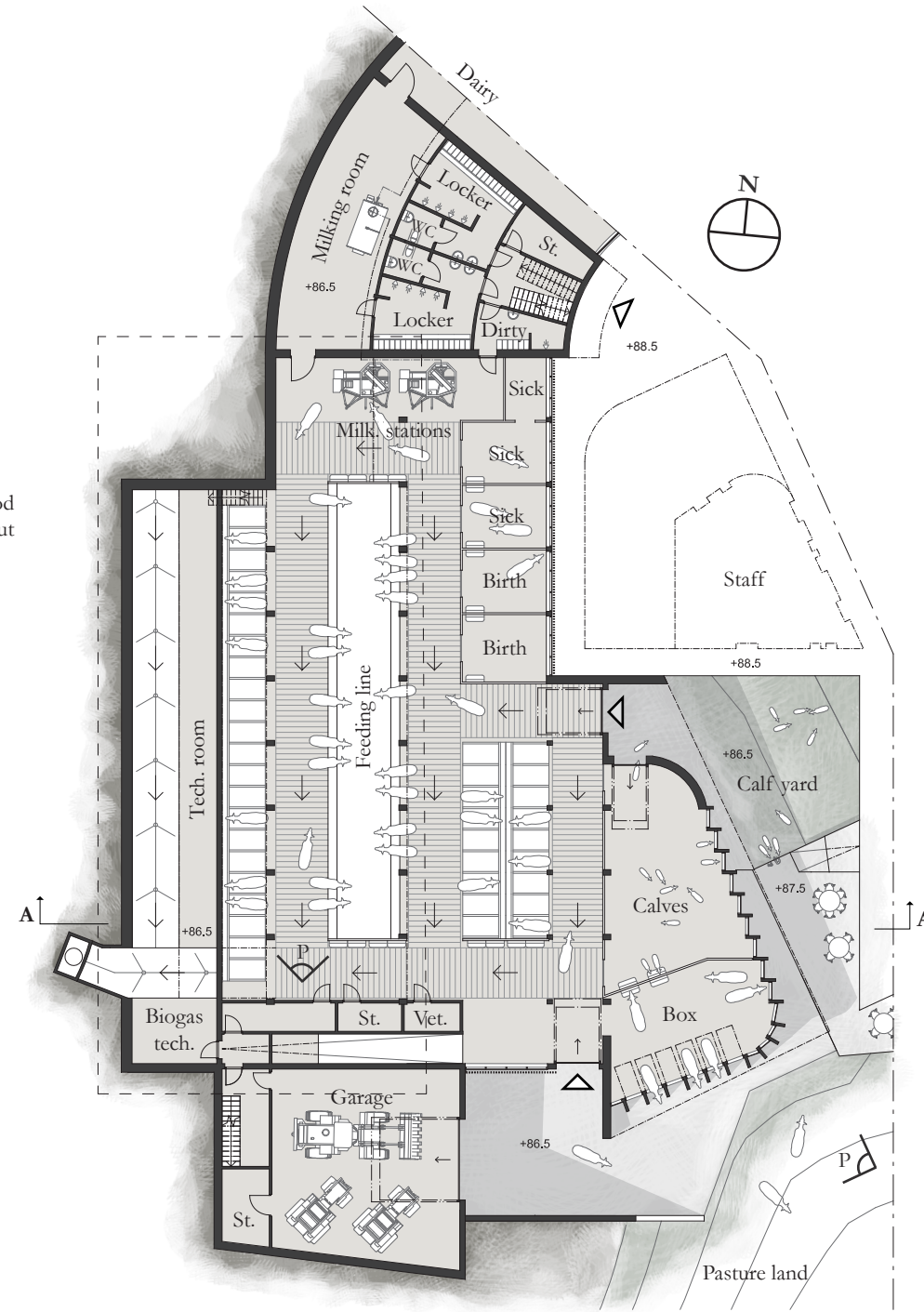

Ground floor - 1:400 (A4)



Inside/Outside

Smart door technology enables cows to move freely between the shed and the pasture land. Calves that can not have this freedom still have the opportunity to go outside to the calf courtyard with the same door technology. The calf-yard is located in direct relation with the viewing deck, enabling kids to cuddle with the calves while the grown ups are tasting cheese. So no need for cow releasing event - the doors are already open.

Climate

Direct daylight is avoided to not heat up the barn. Diffused daylight from the roof structures creates great sense of circadian even though the stable is underground. Due to the massive concrete structure surrounded by earth, and the insulating silage storage above - the shed is kept sustainably cold. Mechanical ventilation takes in air from the soffit and lets it out by the ridge.

Daylight principle detail - 1:20

The deeper area of the cow shed is secured for daylight by a sawtooth roof integrated in the grass landscape. The daylight intake is thereby oriented to the north to avoid direct daylight entering the building.

Slanted concrete slabs acts like beams, and enables the structure to have vegetation as an insulation layer on top.

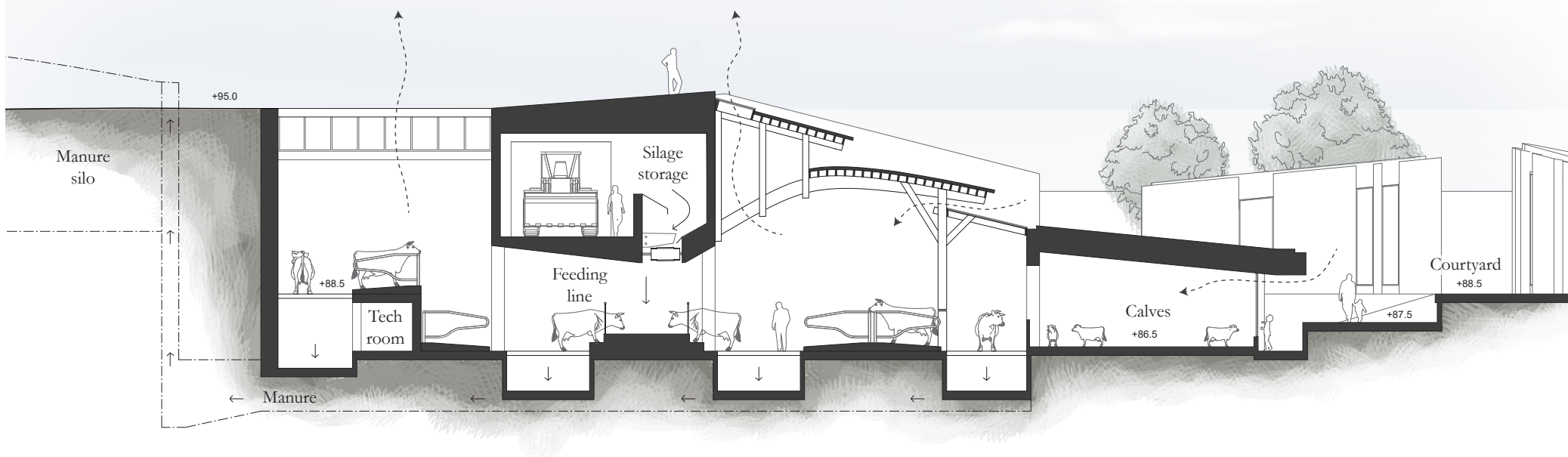

Section A-A - 1:200 (A4)

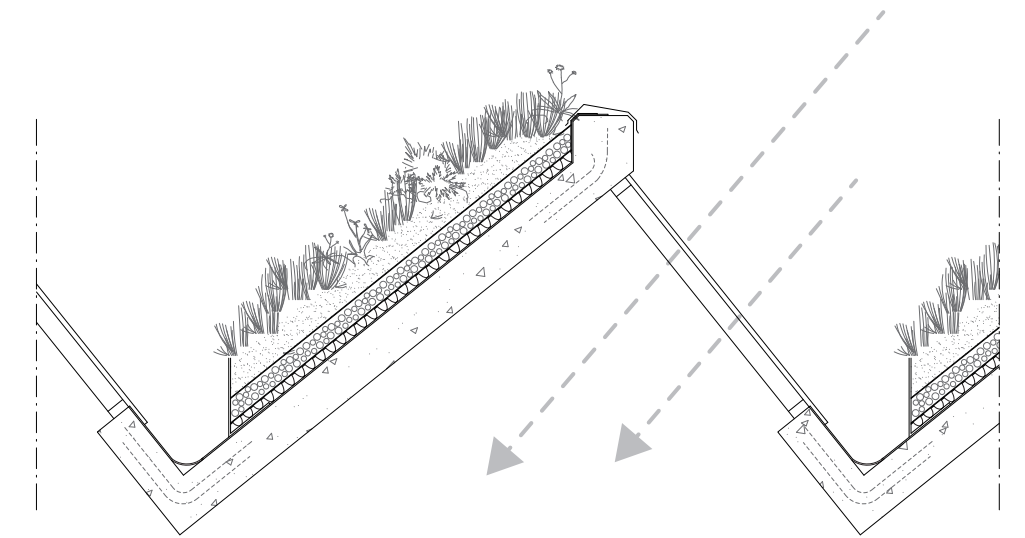

Invisible railing detail - 1:20

To free the landscape from high railings, the ha-ha principle is used to provide safety on the green roof extensions when needed. The railing exists, but is not visible from distance when walking through the landscape.

Green roof vegetation

The green roof typology is dimensioned to hold a thick layer of soil to enable the sites natural vegetation to take over and grow wild. Wild vegetation will maintain itself by creating natural growing conditions for it. The roof extensions becomes part of the pastures and will organically be cut and get nutrition by the cows.

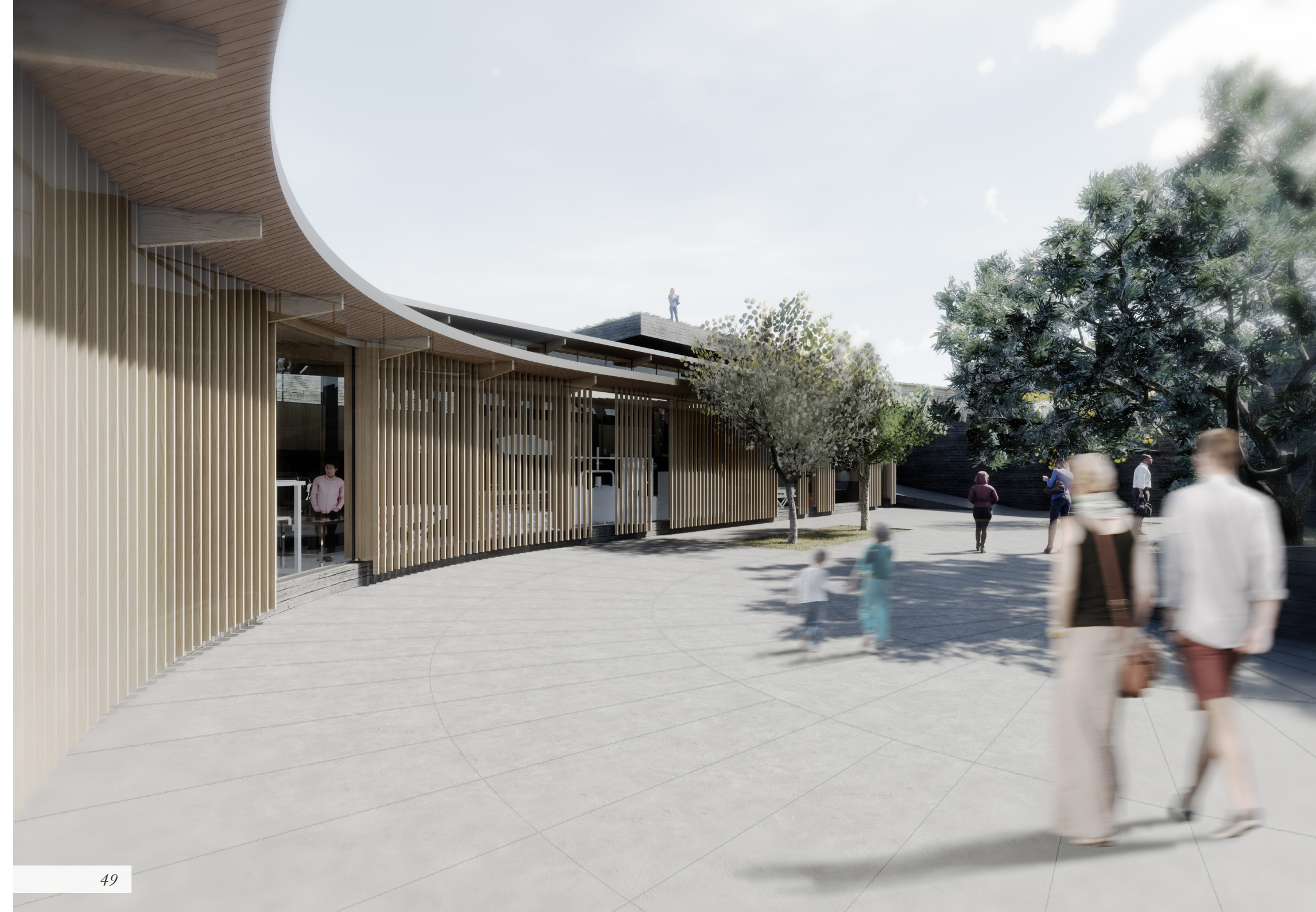
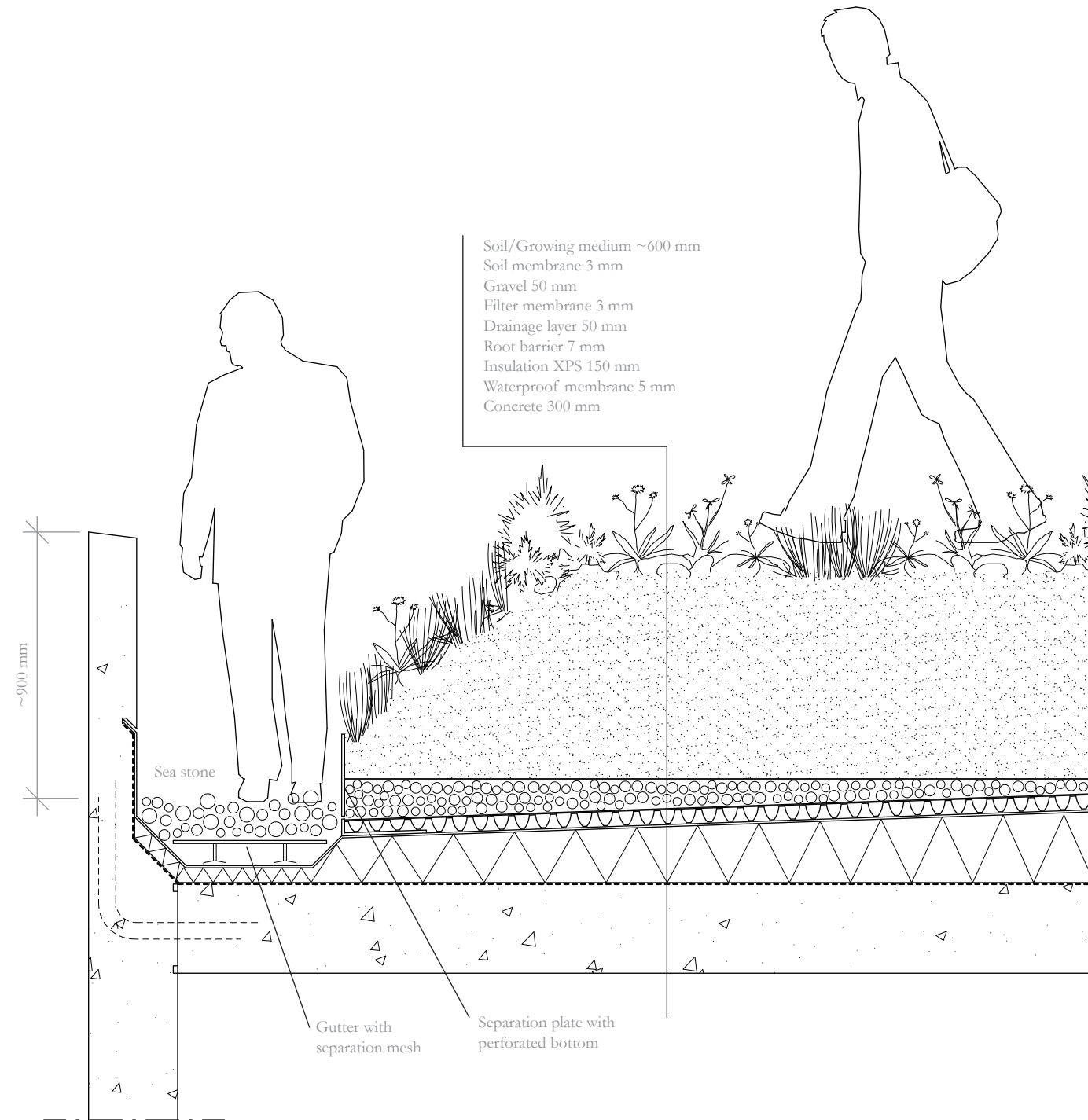

4.11 Dairy factory & courtyard

Layout

The dairy factory sweeps around the courtyard in logic of the production flow. Furthest in is the automated milk processing line on a lower level, whilst the more interesting production lines for cheese and ice-cream are facing the courtyard. It all starts with the raw milk tank and the processed milk is either pumped to the cheese production, or continues on the lower level underneath the lab/dry ingredient storage units to the milk packaging line on the other side.

Storage, functional spaces and the cheese cave are also located on the lower floor, further into the earth mass to obtain good natural climatisation for years of aging.

Some finished products continues via an underground supply tunnel to the farm shop, while most of the products are elevated up to the transportation floor to be delivered to local stores and restaurants by the farms own mini truck.

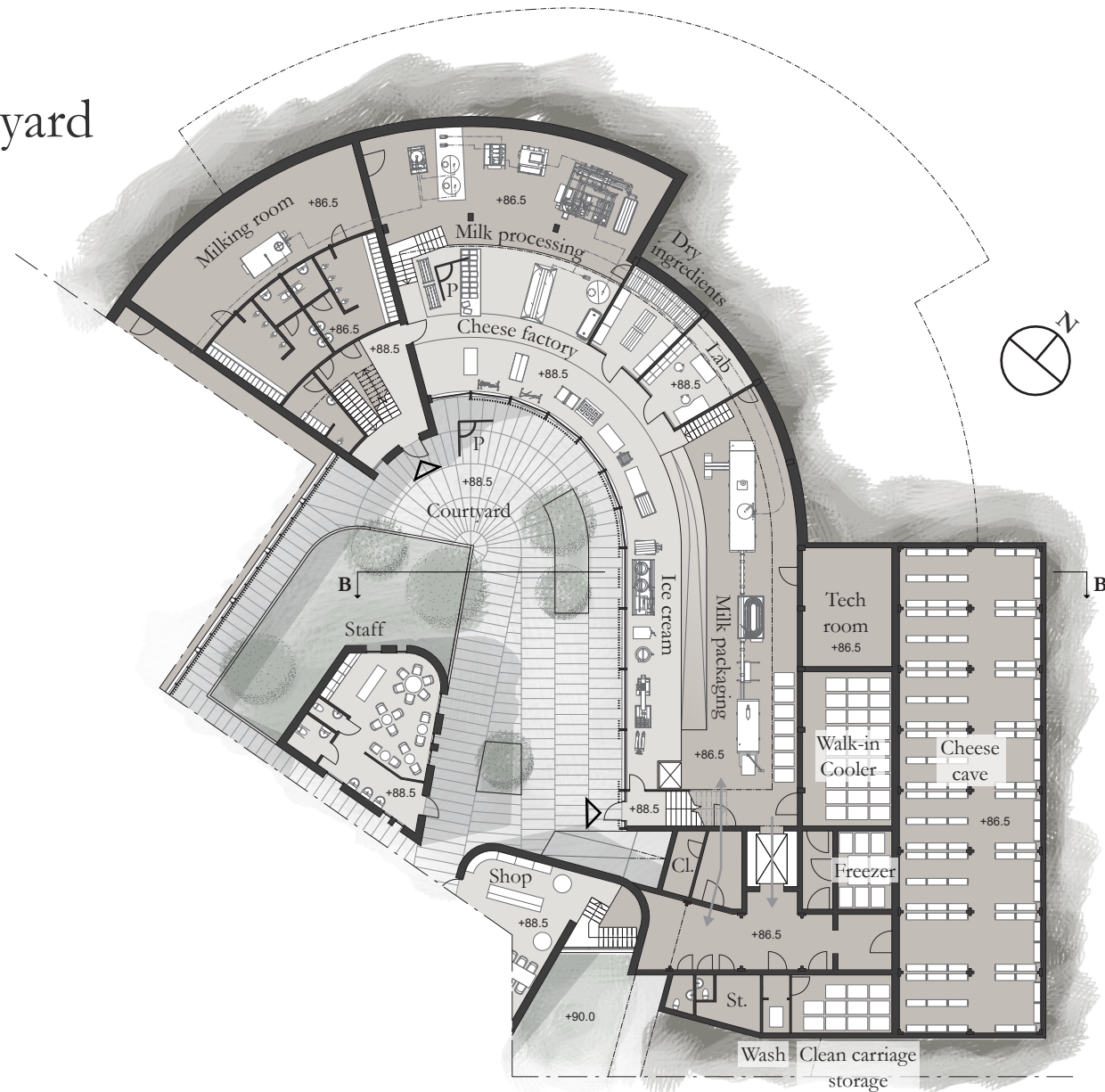

Floor plan - 1:400 (A4)



Typology

In contrast to the heavy concrete structures - the dairy factory has a lighter and more open expression. Different textures and tones of concrete are used up to 300 mm for hygien purposes. A lighter concrete is used here for maximum light and sterility.

The space is covered with a tectonical timber roof to obtain a warmer feeling, and provides diffused daylight from all directions.

The facade facing the courtyard is made out of glass for good hygiene and externally covered with gapped timber boards to keep the transparency but avoid direct sunlight.

Visitor dairy tour

Visitors can choose take a self-guided dairy tour in a separate climated zone on a higher level overlooking the full production. This is a clear example of public transparency on the farm.

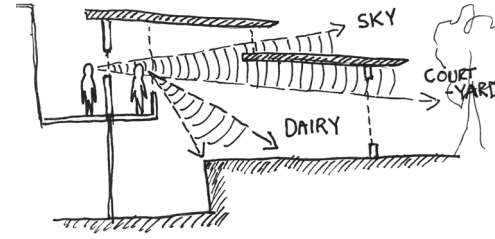

Creating curiosity

On transportation floor, the window sill height, and the dairy tour platform blocks the view of the dairy activities. Spectators can see the sky through the roof gap and get a glimpse of the courtyard. Only when inside the dairy tour visitors can experience the full activity of the dairy processing.

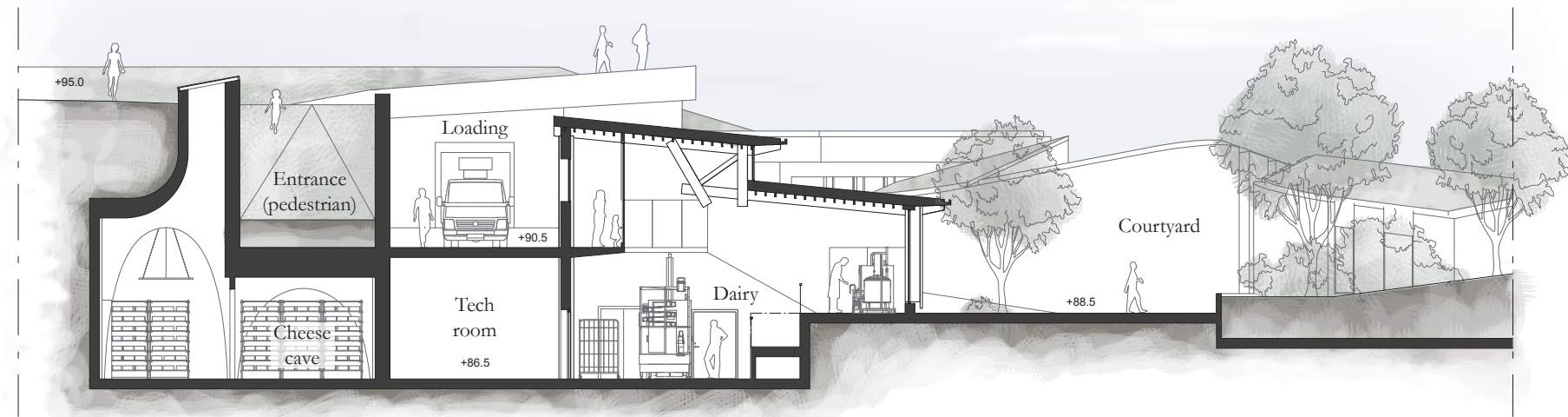

Section B-B - 1:200 (A4)

Dairy equipment system

The type of equipment in the illustration is handpicked and developed for this farms scale, business model, and desired products. The system is designed to work effeciently between the different products produced. The illustration shows the production flow and how desired processing needs can be flexible in the process.

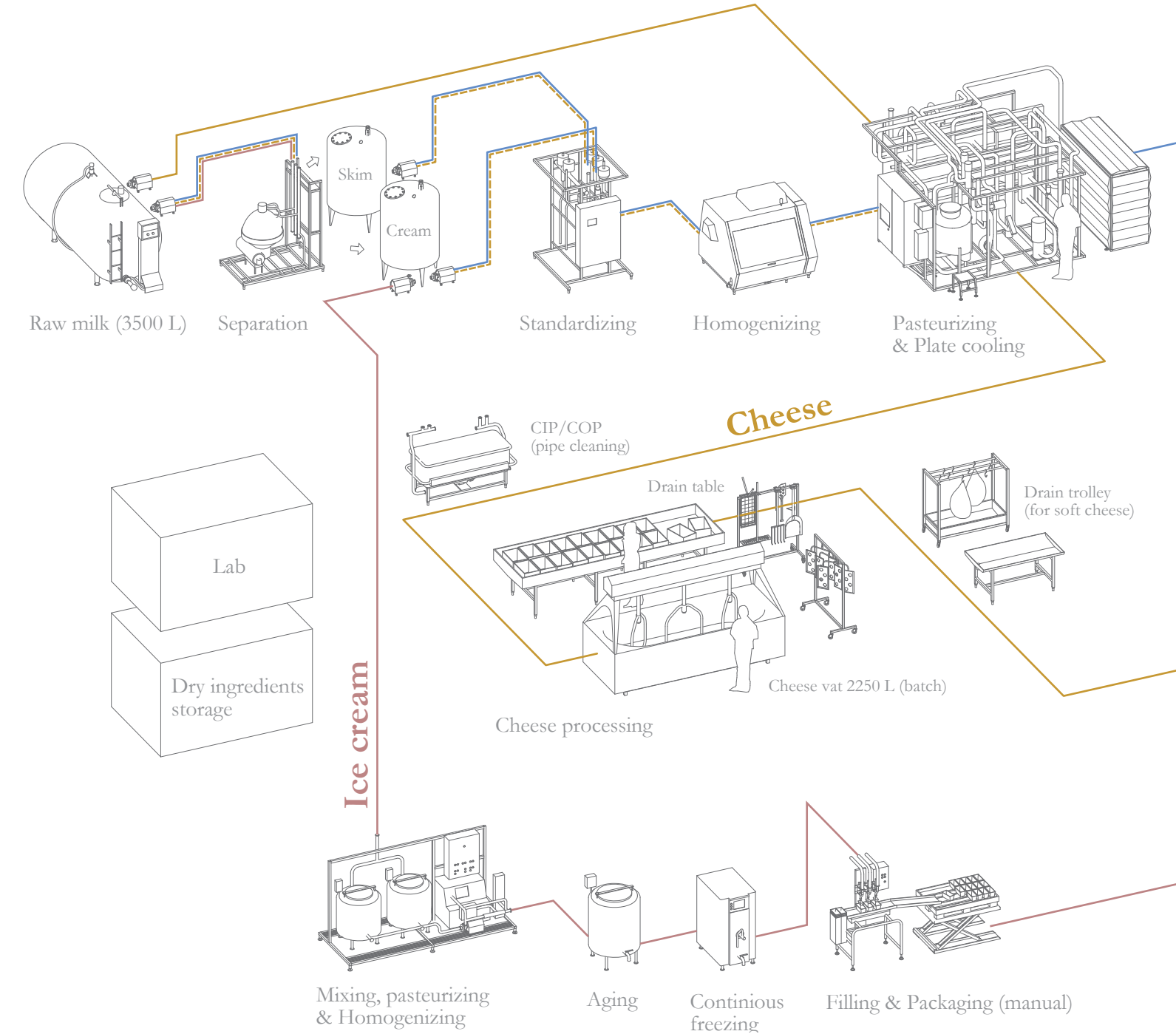

Automation or labour?

As earlier mentioned; the brand product is hard cheese, while the milk production is self-going and efficient. Automated equipment is expensive but reduces labour costs for a long term profit. The diagram below shows the strategy for that balance for this project.

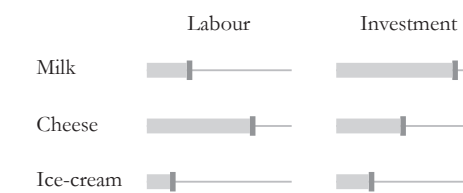

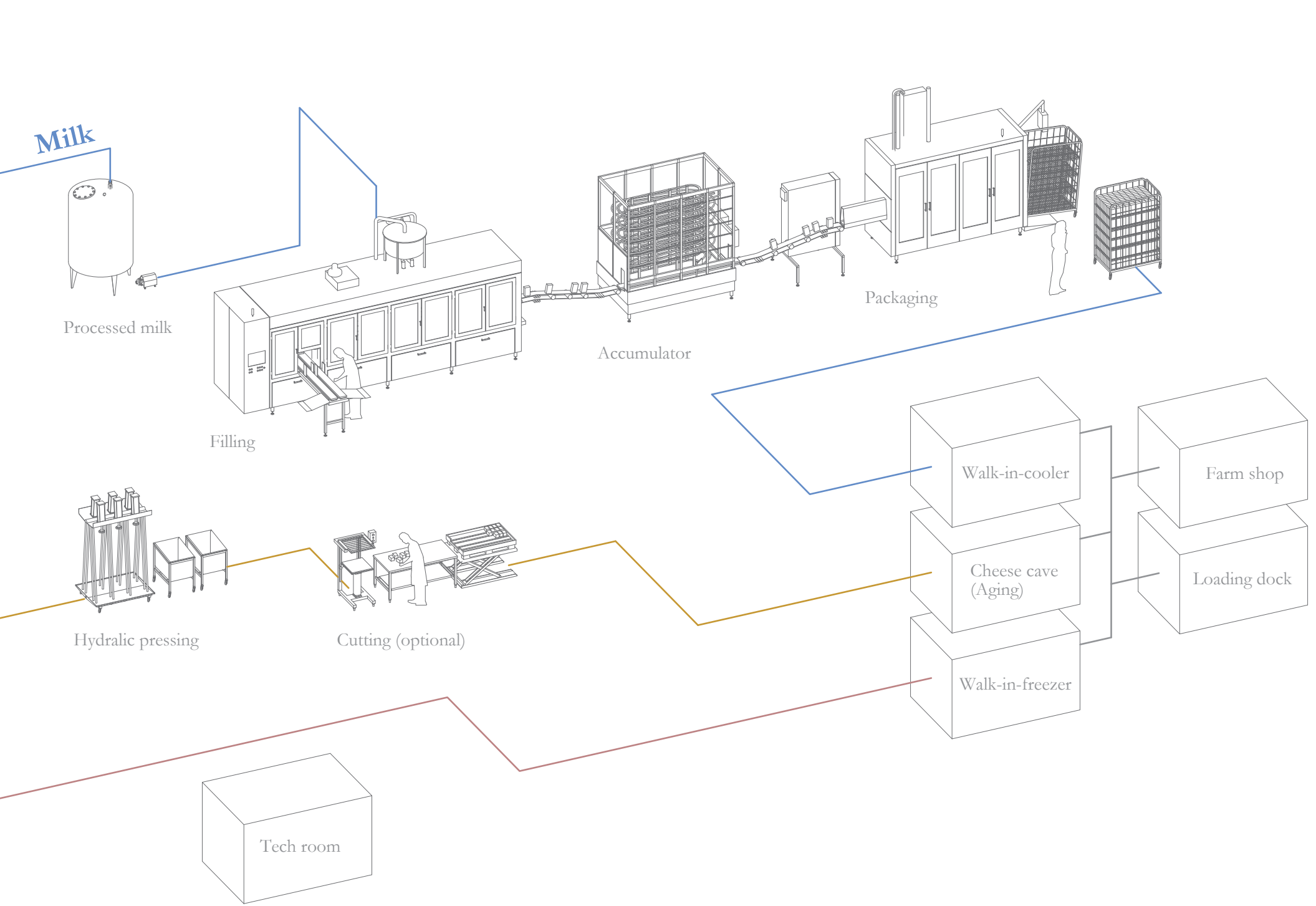

4.12 Southern deck

View deck

The two courtyard buildings creates a narrow passage, dividing the courtyard to create a more outwards deck overlooking the valley.

In this space, visitors are surrounded by the calves in the calf-yard, the farm shop, and a spectacular view.

The hotel is located out in the landscape. After getting your key in the farm shop reception, the hotel is reached by making your way down the platforms and into the grass.

Furniture

This space also contains project specific designed furniture to set the rural mood. Chairs and tables are made out of driftwood, old cable barrels, reinforcement steel bars and reused concrete pipes.

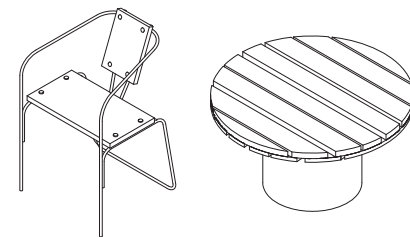

4.13 Farm shop & cheese cave

The farm shop acts like an administrative center for sells, information and reception for the hotel to streamline labor.

Rural food experience

As mentioned, the farm shop does not only serve and sell its own assortment, but also collections of locally produced wines, breads and salads from other farms. This is a win for the farm to be able to offer a larger assortment, to complement products, but also a win for other local producers. in the area.

Rounded concrete walls and slanted roofs takes inspiration from a cave entrance, logically since this is the public entrance to the cheese cave.

Cheese cave

The cave is located completely underground, but has one light well to provide a small effect with diffused daylight. The vertical opening also creates air movement in the cave to counter mold.

The cave can be visited in company of the staff by going down the stair next to the cheese desk.

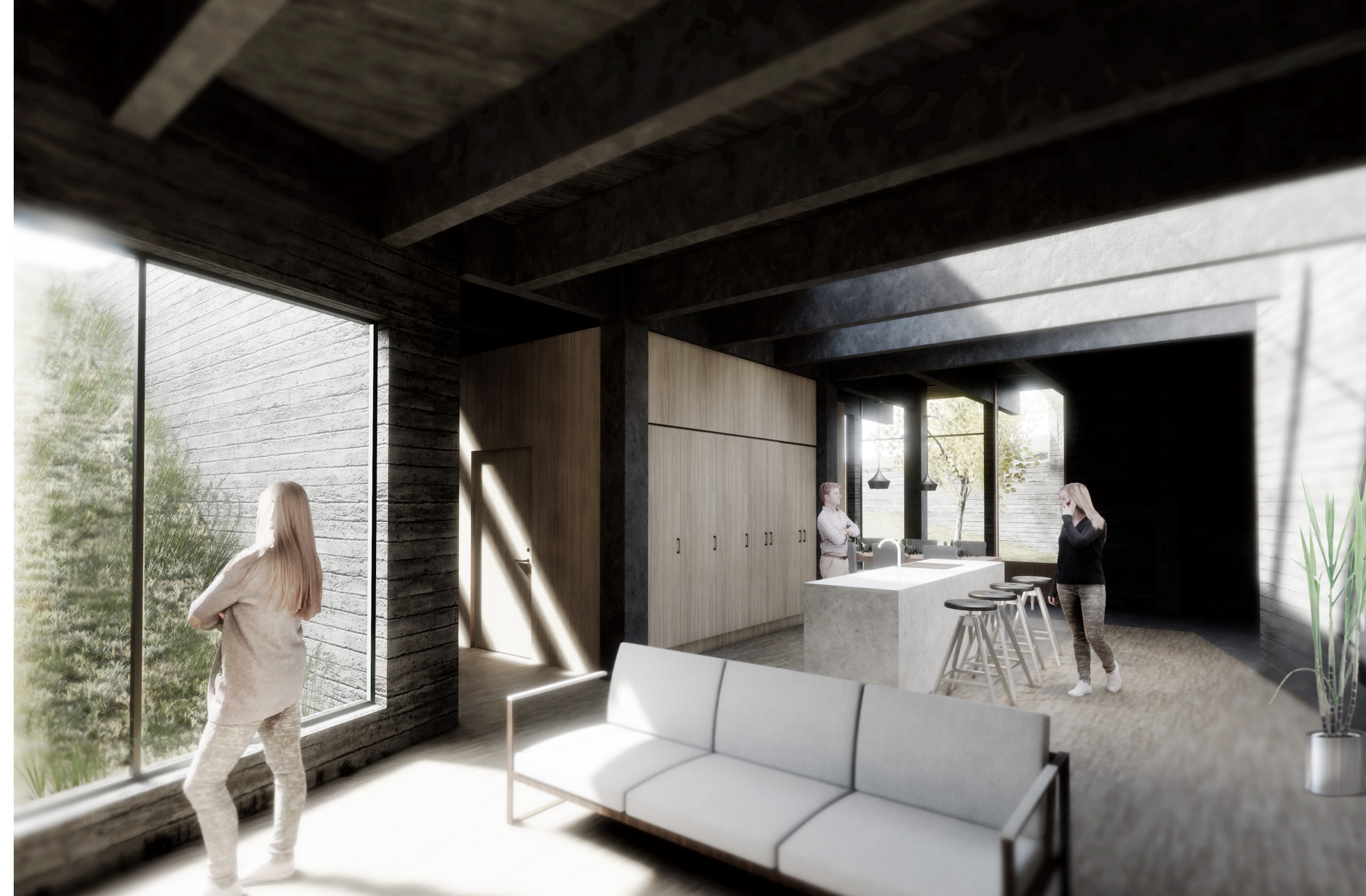

4.14 Farmers house

Farmer family's home is a place for rest and family focus. Located in the eastern wing, mostly underground, the farmers are able to disconnect from work and enjoy the calm evening sun from the south-west facing patio.

Daylight

Thermally insulated by earth mass and a big overhanging grass roof keeps the building sustainably climatized and protects the glassed facade from the hot summer sun. Even though most of it is located underground, daylight features are great with help from an excavated ha-ha inspired lightwell in the deep core. The descending grass slope creates a strong relation with the landscape even in the deep underground core. Daylight is further maximized with help of two skylights; one in the kitchen, second one in the deeper hallway.

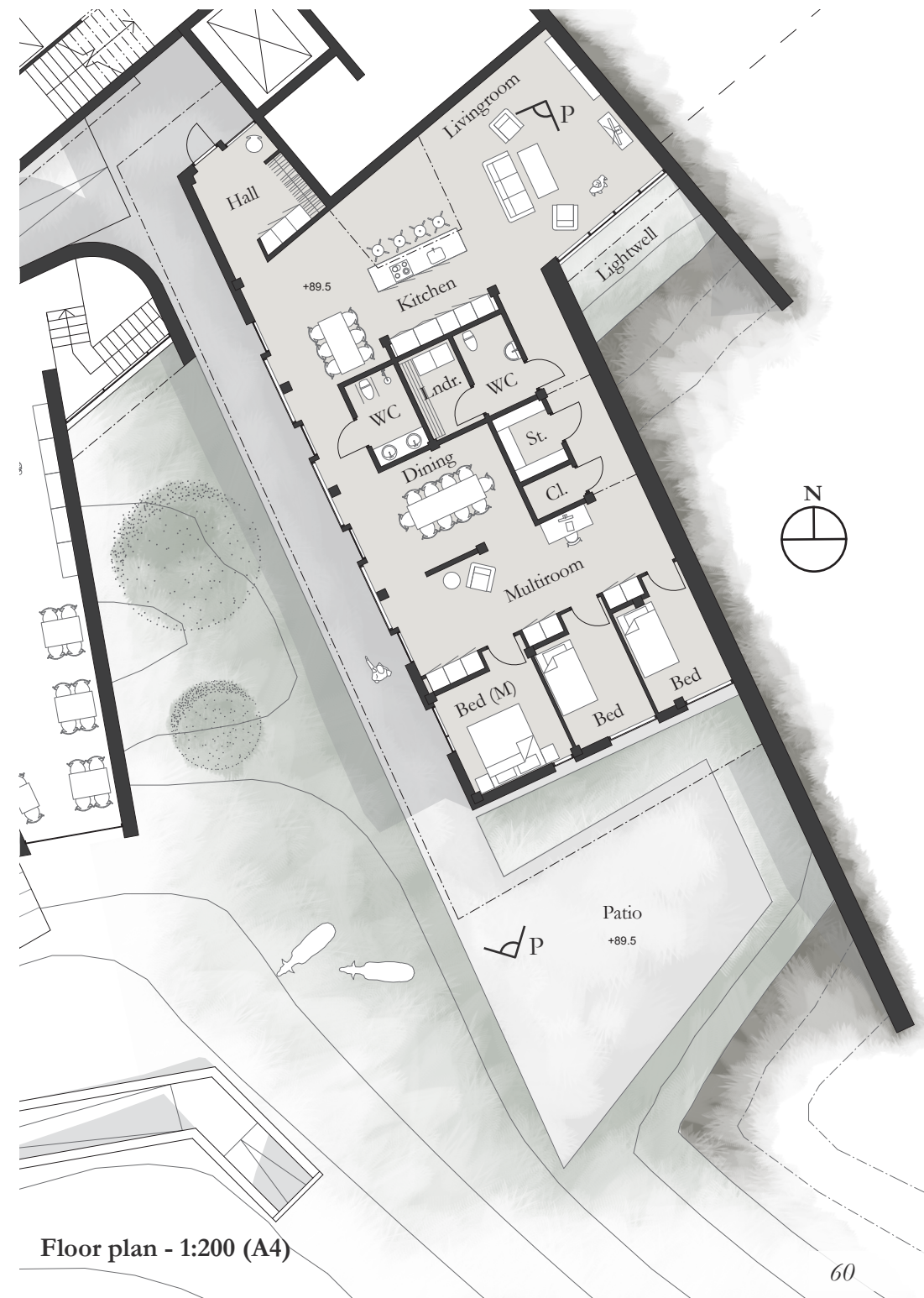

Green roof detail - 1:20

Similar to the earlier detail, this roof is also insulated by vegetation. The house is characterized by high and narrow concrete beams, enabling a thinner concrete slab.

The glass panels are extending all the way up to the concrete slab to create a continuous borderless expression between inside and outside.

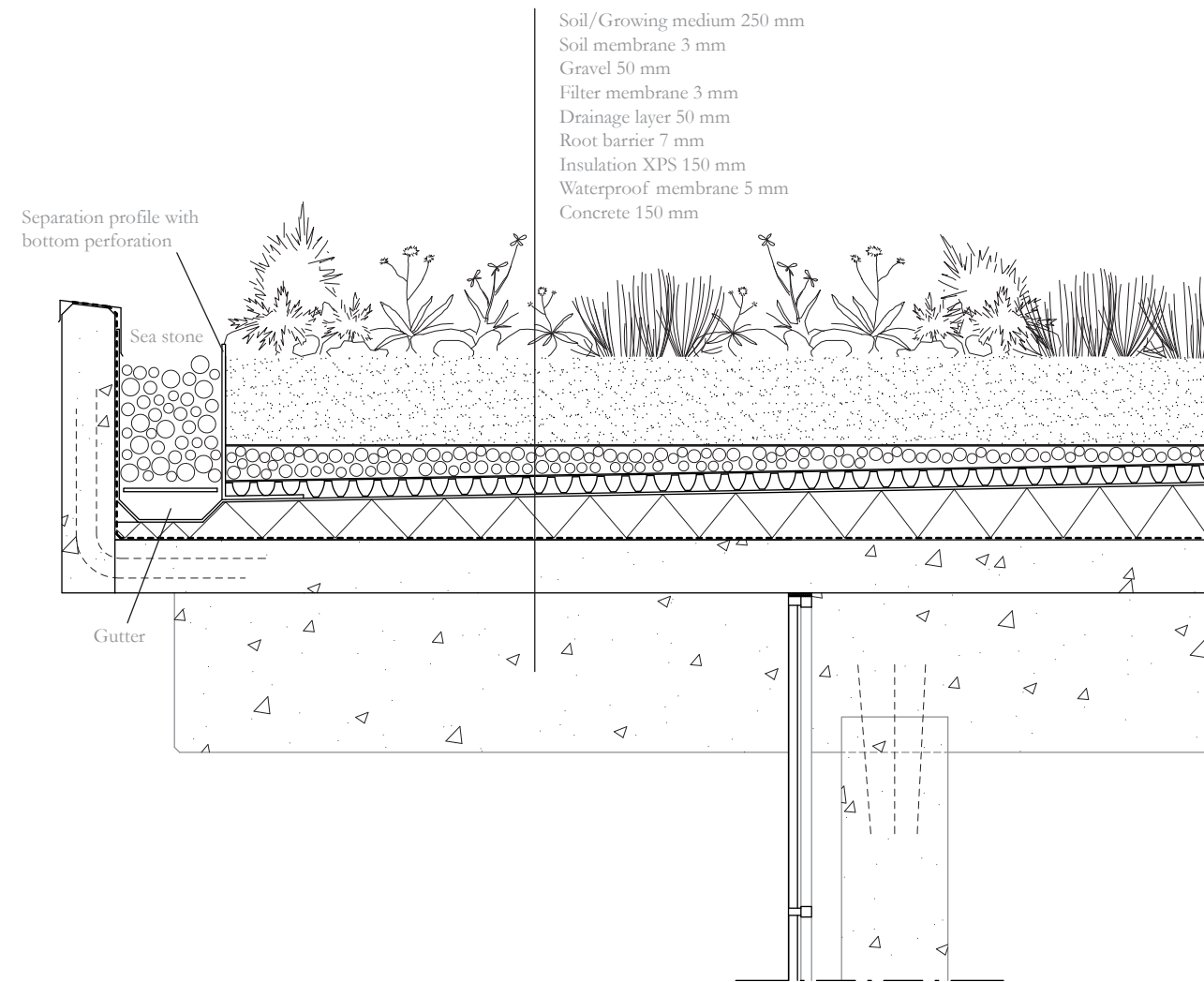

Flexible structure for growing families

The house plays with the heavy/light typologies within the building to provide flexibility. The heavy landscape structure, roof and columns, creates a structural framework to allow this freedom. Internally, the space defining timber walls takes no load, which enables the layout to change smoothly without affecting the structural capacity of the building.

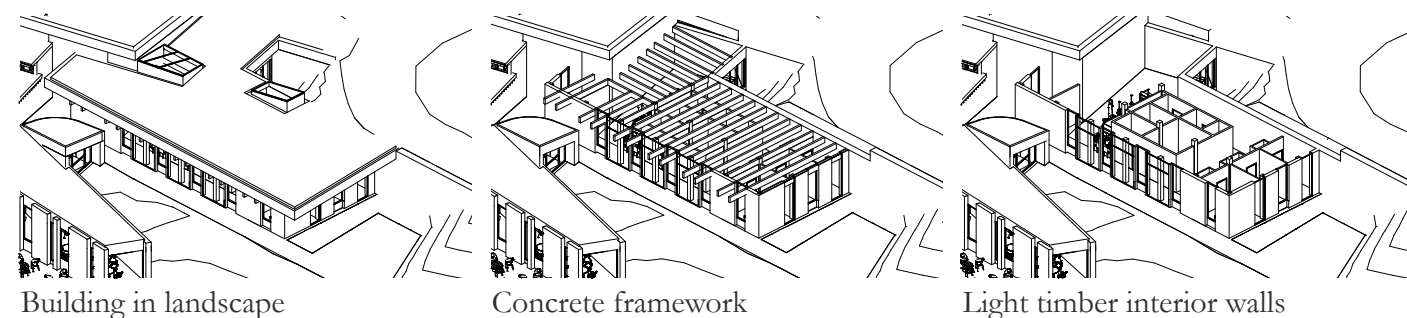

4.15 Pasture hotel

Landscape integration

To be able to give visitors and hikers the ultimate nature experience, the farm also runs a small hotel business. Located further out in the field underground, the pods become a part of the landscape and fragments of the farm like a rockfall.



Reception & breakfast

Administrative functions are located in the farm shop, and this is also where breakfast is served.



A journey into darkness

The design is based on integration with landscape, but also for the experience of appreciating the landscape. Entrance takes place by going through the field and descend into a narrow trench. After a while, the trench is underground and the visitor goes into darkness. When they enter the hotel room they will be carried away by a breathtaking calm presence of light and nature, overlooking the valley.

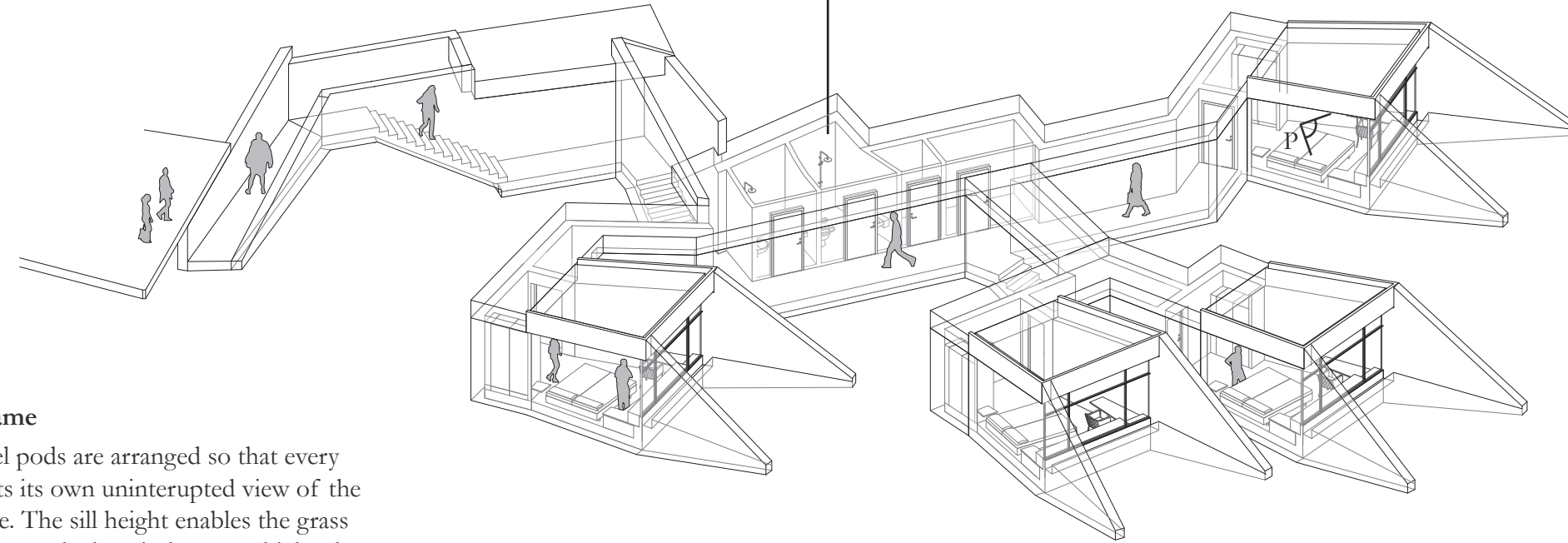

Facilities

Functional spaces and plumbing fixtures are centralized in one location for efficiency. This core contains bathrooms, shared by the four hotel rooms, storage for linen, and cleaning storage.

View frame

The hotel pods are arranged so that every room gets its own uninterrupted view of the landscape. The sill height enables the grass to grow towards the window on a higher level for a stronger presence of the landscape.

4.16 Typologies - Intersection

The following sequence of model photos gives a deeper understanding of how retaining structures and timber structures interact. Starting on the logistic floor, ending

with the courtyard, it shows a transformation of scale, detailing and materiality, from landscape - to humanity.

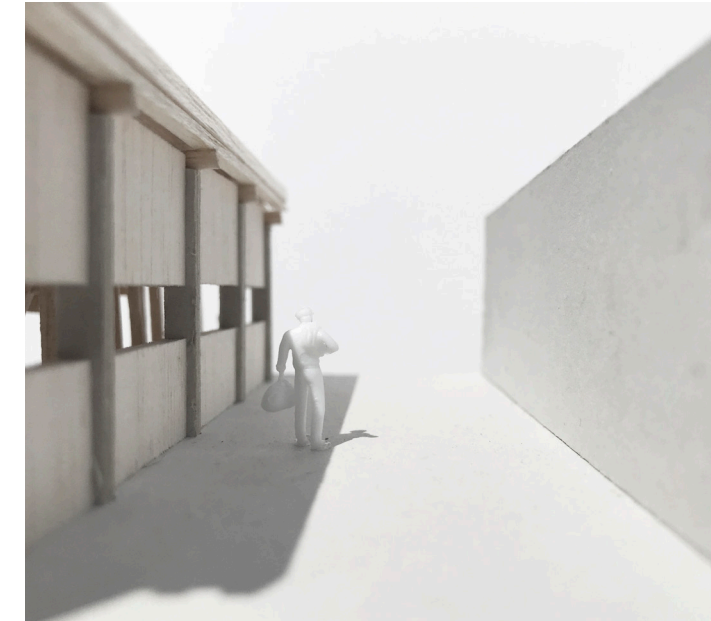

1. Logistic floor

Where retaining structure and timber structure meets. Retaining structure interacts with the landscape, is big scale and clean. The timber structure has high window sills to hint about what's going on inside the dairy, without showing too much to create curiosity to take the tour. This space is closed off to induce movement by directing the focus forward.



2. Dairy tour climate zone

On the other side of the wall inside the dairy tour walkway. Open glass panels direct the focus towards the dairy and the courtyard.



3. Lower dairy floor

Sunken down to give ceiling height for milk processing equipment. It also connects the courtyard level with the underground functional spaces.

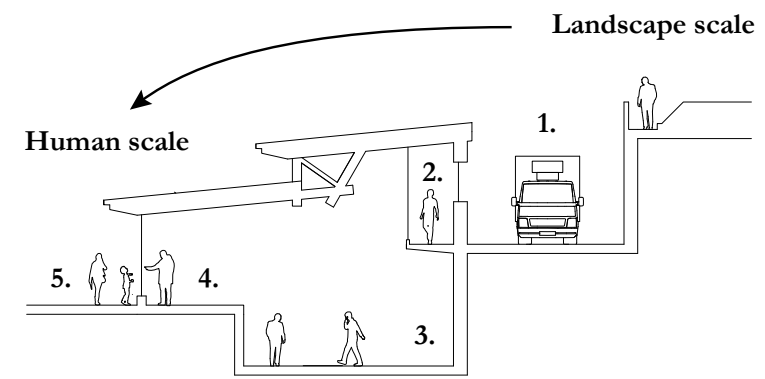

4. Higher dairy floor

Where cheese- and ice-cream production is located. This floor connects with the courtyard and brings down the scale towards it. Image shows how the timber structure is carefully standing on the retaining foundation.



5. Courtyard

This space has an other type of scale and detailing compared to the first image. The building is low, detailed, warm, and has a strong connection between the courtyard and what is going on inside. Vertical gaped timber boards shades from the sun but allows directed transparency.



Lantern

During dark winter evenings, Brösarp dairy farm will become a landmark seen from the village of Brösarp. The otherwise invisible landscape integrated structure becomes a glowing lantern on the top of the hill.

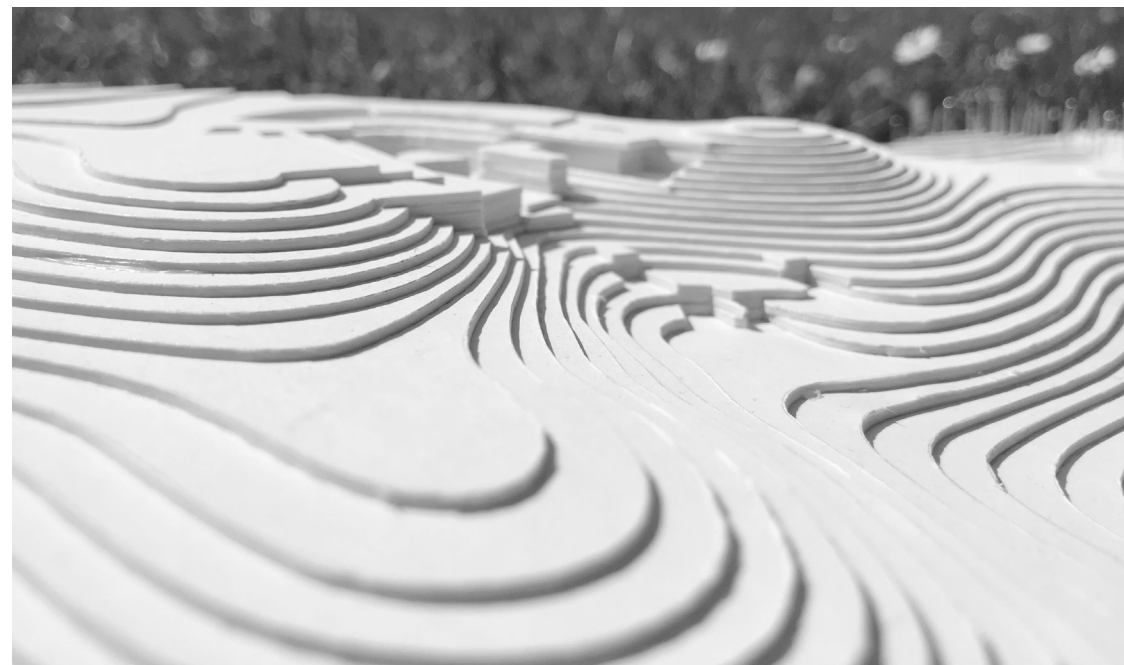

Site model 1:1000

5. Conclusion

The overall aim of this thesis was to explore how architecture can be a tool for solving a theoretical issue - in this case, connecting farmers and consumers. The aim was also to investigate how architecture can respond to context - in this case, by natural integration and inferiority.

This thesis investigated how different departments, that within themselves contains different demands, restrictions, flows and functions, can be combined and enhance an architectural expression, influenced by a specific, developed context approach.

The work was developed with a strong consideration towards the users. Users are in this case defined as cows, farmers, staff and visitors. The architectural approach refers back to the user experience, to create ultimate conditions for good life on the farm, both for cows and humans. Transparency was an important factor, both within the production and as physical. My conclusion is that transparency affects visitors emotionally by letting them get closer to the production, but also as a tool to ensure sustainable animal care, and a healthy production.

The production as a function was developed with a consideration to context, translated into a solution based on a simple production flow logic combined with a strategy to solve the complexity of levels on the site. By clearly defining usage for the different levels; in this case, separating vehicle logistics from human use, the project developed to become a logistical efficient farm in the same way as it becomes dedicated to human use and human scale.

This thesis project have brought light to a new perspective of what agriculture could be; a public attraction that spreads knowledge and lets consumers get closer to the products origins. Learnings from this thesis makes me believe that farms could benefit from not being a closed business, and a link in the chain. Small scale entrepreneurship is a business form which could definitely be developed within agriculture, to give farmers control over the production and benefit from the demand of locality. For future exploration, I believe that it would be interesting to see how the consumers and the public could play an even bigger role, how agriculture could link into other businesses,

and benefit from other local attractions that are in proximity to the site.

In terms of architecture, I believe that it would be interesting to explore how architecture could be integrated with nature in a more open-ended way. Architecture that allows future flexibility and expansion. It would also be interesting to develop and investigate more of the social aspect of a farm.

Agriculture often relates to a certain type of architecture, nowadays often based on rationality and efficiency. By giving agriculture a new meaning, we also create a need for new architecture. An architecture that imposes social interaction. An architecture that becomes a tool to solves new theoretical issues.

6. References

Sveriges Radio. (2012). *Mjölkbönder protesterar: "Vi får sämre och sämre betalt"*. (Online) Available at: <http://sverigesradio.se/sida/artikel.aspx?program-id=114&artikel=5347285> (Accessed: 2018-03-08).

LRF. (2017). *Mjölkrapporten nr 1 2017: Högre mjölkpris men lägre mjölkproduktion i Sverige*. (Online) Available at: <https://www.lrf.se/om-lrf/press/press-meddelanden/2017/mjolkrapporten-nr-1-2017/> (Accessed: 2018-03-08).

LRF. (2016). *Mikromejeri en möjlighet för hårt pressade mjölkföretagare*. (Online) Available at: <https://www.lrf.se/mitt-lrf/nyheter/riks/2016/10/mikromejeri-en-mojlighet-for-pressade-mjolkforetagare/> (Accessed: 2018-03-08).

Washington Post. (2017). *The surprising number of American adults who think chocolate milk comes from brown cows*. (Online) Available at: https://www.washingtonpost.com/news/wonk/wp/2017/06/15/seven-percent-of-americans-think-chocolate-milk-comes-from-brown-cows-and-thats-not-even-the-scary-part/?utm_term=.063b4892af6b (Accessed: 2018-04-05).

Goff, D. (no date). *Dairy Science and Technology eBook*. (online) Available at: <https://www.uoguelph.ca/foodscience/book-page/dairy-science-and-technology-ebook> (Accessed: 2018-04-18).

Livsmedelsverket. (2017). *Varför pastöriseras mjölken?*. (Online) Available at: <https://www.livsmedelsverket.se/livsmedel-och-innehall/mat-och-dryck/mjolk-och-mejeriprodukter/varfor-pastoriseras-mjolken> (Accessed: 2018-04-18).

Hill, A (no date). *Cheese making technology eBook*. (Online) Available at: <https://www.uoguelph.ca/foodscience/book-page/cheese-making-technology-ebook> (Accessed: 2018-04-18).

Goff, D. (no date). *The Ice Cream eBook*. (Online) Available at: <https://www.uoguelph.ca/foodscience/book-page/ice-cream-ebook> (Accessed: 2018-04-18).

Ulrich Lange: *Ekonomibyggnader på skånska herrgårdar. Idéhistoriska speglingar i lantbrukets arkitektur*. Nordiska museets förlag, Stockholm 2008. 207 s., ill. ISBN 978-91-7108-524-5.

7. Thanks to

- Bernt Nilsson - Supervisor
- Christer Malmström - Examinor
- Tengbom Malmö - For supplies and support
- Ådala gård - Micro-dairy
- Kasper Molin - Dairy farmer
- LTH A-library - Books and reseach
- Friends, family & beloved - For help and emotional support