

*Network Densification and Energy
Efficiency*

Sarthak Das
wir14sda@student.lu.se

Department of Electrical and Information Technology
Lund University

Supervisor: Maria Kihl

Examiner: Maria Kihl

November 11, 2018

Abstract

The galloping pace of development in the field of wireless communication has left the world astounded over the last decade. But this has also led to a wild and inexcusable extravagant expenditure of energy. Due to the dynamic nature of wireless network, it has become imperative to focus more on energy efficiency and achieve desired Quality of Service (QoS). The challenge of diminishing the carbon footprint and cutting down the operating expenditures and keeping up with the bludgeoning demand for coverage and capacity is the main driving force or motivation behind studying energy efficiency of mobile networks and delving into the latest research on power saving features.

Long Term Evolution (LTE) is our prime topic of focus as it has within a small span of time proved to be the right technology to cater to the requirements of the ever-growing demand and is widely considered to be the answer to future’s new and existing wireless networks. The provision of quality service has to take into consideration the maximum utilization of LTE resources as it is profitable to both the operators and the environment. To be in harmony with this arrangement the requirements on energy performance will appertain to the specifications of immediate 5G networks. In LTE networks, indoor small cells are deployed in large volume to boost performance in areas with lousy macro coverage or high traffic demand that has botched the entire network. This type of network topology, that involves a mix of radio technologies and cell types working immaculately in a well-organized manner is called a heterogeneous network (HetNet).

An attempt has been made to study the energy efficiency of various Het-Net deployments in disparate environments (dense urban, urban, sub-urban and rural). The small cells deployments examined are pico base stations and micro distributed-antenna-systems. A comparison has been made between dense and sparse deployment strategies with varying transmit powers. Furthermore, an investigation has been carried out to identify the potential for energy savings by placing the small cells into a low power sleep state under certain established conditions. Both brief sleep periods between transmissions which could be described like momentary muting, called discontinuous transmission (DTX), and lengthier sleep cycles during periods of little activity has been investigated. This thesis was carried out as a project at Ericsson Systems & Technology in Lund, Sweden 2016.

Acknowledgments

Foremost, I would like to express my sincere gratitude to my Supervisor and Examiner: **Maria Kihl** for her continuous support to my study and research, for her patience, motivation, enthusiasm, and immense knowledge and all the useful discussions, especially during the difficult conceptual development stage. Her deep insights helped me at various stages of my work. Her guidance helped me in all the time of research and writing of this thesis.

I would also like to thank **Cecilia Andersson** and **Anders Ericsson** from System & Technology, Ericsson Lund for all the aid and taking time to answer all the questions and structure the network model.

Finally, I would like to thank my family for the support and encouragement.

Preface

This master thesis is collaboration of the Department of Electrical and Information Technology (EIT), Lund University and Ericsson Research. The research described herein has been conducted under the supervision of Prof. Maria Kihl.

This work is to the best of my knowledge with proper references made to previous work. A year ago, this project was started and it turned out to be a long enduring battle. This paper is a short report of that extended process. What I cannot express in this report is the joy for every successful code execution, hope for good results and the glumness and fatigue with each failed attempt. The aim is to introduce the reader to current green technologies and outline the necessity for energy efficiency in information and communication technology.

Popular Science Summary

There is a famous saying that states "Wasting of power is an invitation to future darkness. So, for a better tomorrow, save energy today". This is so true that even some governments have adopted initiatives with a goal of reducing carbon footprints. The primary intent of this paper is to outline the significance of energy efficiency in contemporary telecommunication networks and espouse views and theories for optimizing network performance in terms of energy demands and have a feel of the evolving energy efficient technologies trends worldwide.

Telecommunications might be one of the industries consumers dislike most because of the sub-par service but a coming upheaval in communications technology could soon turn it into a smart, responsive provider of digital services which is both needed and appreciated. For decades, the telecom industry relied on a simple model: build the biggest network and then charge customers for the demands. But now, HetNet has undergone some major enhancements, network densification strategies in particular, to ensure unparalleled performance and synergy with the macro network. This has led to energy demand which is increasing at a fast pace all around the world and if not controlled it would lead to energy shortage. This can be minimized by just taking small smart measures. Bringing in some killer energy saving features could revolutionize the Telecom industry. Furthermore, it would promote the concept of green telecommunication networks and provide information about the power consumption within wireless communication networks. The aim is to introduce the reader to current green technologies and essentialize the necessity for energy efficiency in information and communication technology.

The term "Green Communications" has now become so ubiquitous that it is a quotidian routine to refer it in every Telecom conference. In Telecom networks "Green" would refer to minimizing consumption of energy through the use of energy efficient telecom technologies and renewable energy resources. According to a survey, the telecommunications sector accounts for roughly 4 percent of the global electricity consumption. To reduce energy consumption the Telecom sector has been actively participating in efforts to reduce energy consumption – both for economic rationale and for environmental reasons. The most marked project is the Energy Aware Radio and network TechNologies (EARTH). Initiatives like EARTH has been helpful to pinpoint telecom-specific energy usage in the network

infrastructure arena. By collaborating with research institutions and universities, EARTH’s coordinated knowledge could easily influence our future network designs, with the goal of reducing carbon footprints.

Not to forget the ultimate goal is to obtain a full-blown throughput and improved performance. To begin with, a balance between performance and energy efficiency was struck, ensuring that the performance was not affected and, thus, keeping the energy in check. This was facilitated by applying a power model, traffic model and energy saving features. A power model was adopted after studying the baseband architecture comprehensively. The base station was broken down into different model components which were further split into sub-components till the most fundamental element was reached. Though it might appear complex, it is not so and comparisons can be drawn with the divide and conquer algorithm where we recursively break down a component into sub-components until they become simple enough to be solved directly. A traffic model played an important role because of the uncharacteristic nature of data traffic. This model focussed on three aspects- user activity, ratio of busy hour in a day and the ratio of active users in that busy hour. What followed next was exercising some efficient energy saving techniques to these models to give a rough picture of what could be achieved. These power saving features were applied to very different environments. This was done by aligning the subscribers uniformly for the simulations. Despite increased traffic and service expansion total network energy consumption was minimized by 30%.

An interesting observation was that highest savings was found in rural areas. It has been a common conviction that most energy savings can be made where traffic is high and so maximum efforts are devoted to this section and in doing so turning a blind eye to the wasteful energy consumptions in other scenarios. This stems from our inadequacy to conceive the notion that our intent is to maximize energy efficiency which differs from total energy consumption. But the investigation has proved otherwise and it is now established that it is the rural area where maximum power savings can be realized.

I believe this work could be a good background for future studies. It is true that the study suggests that energy performance requires addressing mostly in low traffic situations but it could also be applied to generic scenarios. Only a handful of combinations(traffic model plus activity type) were picked for the simulations based on some calculated judgement but it would be riveting to witness if such substantial savings can be observed in some other scenarios.

Table of Contents

1	Introduction	1
1.1	Energy Efficiency and its Essence	1
1.2	Power Consumption in LTE	3
1.3	Background	3
1.4	Motivation	4
1.5	Problem Formulation and Method	6
1.6	Outline of the Thesis	7
2	Previous Work	9
3	LTE and OFDM	17
3.1	Downlink Frame Structure	17
3.2	Uplink Frame Structure	19
3.3	Orthogonal Frequency Division Multiple Access(OFDMA)	21
3.4	OFDM Cyclic Prefix	24
3.5	MIMO (Multiple Input Multiple Output)	24
4	Heterogeneous Network	27
4.1	Summary	27
4.2	Improve Macro	31
4.3	Densify Macro	33
4.4	Addition of Small Cells	36
5	Energy Consumption of Mobile Networks	39
5.1	Energy Consumption Metrics	39
5.2	Energy saving features	41
6	Traffic Model	53
7	Power Model	63
7.1	Base Station Power Models	63
7.2	Structure of the Energy Model	63
7.3	Radio Shelf	70

8	Results	71
8.1	Prelude	71
8.2	Power Calculation Prior to Energy Saving Features	71
8.3	Power Calculation after Energy Saving Features	76
9	Discussion	85
9.1	PSI	86
9.2	Cell Sleep	86
9.3	Lean Carrier	87
9.4	RU Micro Sleep	87
9.5	RU FPLC	87
9.6	Tabulation	87
10	Conclusions and Future Work	89
	References	91

List of Figures

1.1	Power consumption of a typical wireless cellular network, source Vodafone	4
1.2	Base station power consumption breakdown(Globecomm 2010, P.Grant and S.Fletcher,MVCE doc.O-GR-0053)	5
2.1	Protocol stack of wireless network	10
2.2	High efficiency PA used in PANAMA	12
2.3	Power consumption per user for different levels of macrocell support, Vodafone	14
2.4	Area power consumption as function of inter site distance for different deployments	15
3.1	Type 1 LTE Frame Structure.	18
3.2	Type 2 LTE Frame Structure.	19
3.3	Uplink-downlink configuration.	19
3.4	Uplink frame structure.	20
3.5	OFDM a form of multicarrier modulation.	21
3.6	OFDM- orthogonality.	22
3.7	OFDM-immunity to selective fading.	23
4.1	pico-cell basestation	30
4.2	Network Map	34
5.1	Energy Saving for E-UTRAN	42
5.2	Cell Sleep Mode Operation Sequence	43
7.1	Base station components included in our power model	64

List of Tables

5.1	Values of C	41
5.2	Micro Sleep Tx features	45
5.3	Mimo Sleep Parameters	47
5.4	Mimo Sleep Related Features	48
6.1	Population density and related inter site distance (ISD) scenarios	53
6.2	Busy hour traffic scenarios	54
6.3	Traffic essentials from Ericsson Mobility Report (2014 Nov)	55
6.4	Ratio of Devices	55
6.5	RAT Deployment	55
6.6	Traffic and Coverage (2017)	56
6.7	User activity based on total area (LTE- 2017)	56
6.8	User activity based on total subscribers (LTE- 2017)	57
6.9	Traffic model of Dense-urban high activity scenario	59
6.10	Traffic model of Urban medium activity scenario	60
6.11	Traffic model of Rural low activity scenario	61
7.1	Parameters affecting scaling of baseband and RF power consumption	66
7.2	Linear power model parameters	68
7.3	Micro BS power model parameters	69
8.1	RBS Components Distribution (2017)	72
8.2	RBS Components Distribution (2017)	72
8.3	Power Consumption of DUA, DUB and RUA,RUB (2017)	73
8.4	Power Consumption of DU(2017)	74
8.5	Power Consumption of RU(2017)	75
8.6	Power Consumption of RU(2017) with PSI	77
8.7	Timing Scenario per Day(24 hours)	78
8.8	Power Consumption of Active RU with Sleep Mode ON(2017)	78
8.9	Power Consumption of Inactive RU with Sleep Mode ON(2017)	79
8.10	Power Consumption of RU with Lean Carrier(2017)	81
8.11	Power Consumption of RU with Micro Sleep(2017)	82
8.12	Power Consumption of RU(2017)	83
8.13	Total Energy Calculation before Savings(2017)	84

8.14	Total Energy Calculation after Savings(2017)	84
9.1	Impact of Energy Savings for RUA	88
9.2	Impact of Energy Savings for RUB	88

1.1 Energy Efficiency and its Essence

The mighty travail involved in reducing energy consumption in a radio base station brings about many gratifying effects. It is very much apparent that the operational expenditure(OPEX) cost for the operator is decreased as the energy bill gets slashed. Also, the capital expenditures(CAPEX) cost gets lowered as there are now means to design battery backup and cooling systems with more unrestrained requirements. There exists a possibility to employ inexpensive components which fits within the budget. For instance, there is not always a need of high capacity for battery backup and in those circumstances, it is viable to embrace the idea of selecting battery cells with acid-lead rather than using the commonly used lithium-ion which would be more expensive. Another, decent example would be the operation of passive fans for the purpose of cooling instead of squandering resources to build an air conditioning system. This greatly reduces the overall cost and in the process induces a good business solution to the operators who are provided with lucrative offers to swap their antediluvian and obsolete equipment for a newfangled paraphernalia.

This turnabout has already begun and today there is a growing propensity to displant old base stations with the new energy efficient ones. On first thought, this might look like a badly conceived concept as it involves a huge investment, but the return of investment (ROI) for such infusions can be walloping after it has been recovered in maybe a couple of years. This makes equipment exchange a bewitching option for many operators, thereby fostering good business plan for networking companies. An incidental benefit is that this paves the way for impending HSPA and LTE contributions to these operators because the newly developed base stations are conditioned for the changes.

Technological advances have led to significant and impressive design impacts and smaller form factors have become feasible according to Moore’s Law [25]. These smaller form factors make an efficient use of the modest space, providing higher flexibility in placing the individual components within a larger assembly, limited use of resources, and makes the transportation considerably easy. It is a common knowledge that by decreasing the RBS energy consumption would create

less heat inside the cabinets and that would result in the habilitation of a diminished RBS form factor. The amount of heat that gets dissipated from the base station determines its size and decides the fundamental limit.

There needs to be sufficient room for air flow and cooling fins around the scorching components for the heat riddance. Therefore, it would be appropriate to conclude that by reducing energy consumption is one of the most vital thing in order to develop compact and yet exceedingly competent base stations. It is always a herculean task to find new sites to install a base station in dense urban areas. But, with reduced footprint it has somewhat made this search for new sites less cumbersome. This could be counted as a significant improvement but sometimes, there is a limit to the accrument of new sites. So alternatively, provisions can be made to fit in more capabilities (more radio-access technologies (RATs), more carriers, etc.) and more features in existing sites by keeping the form factor unchanged. At present, the operators have endeavored to entirely remove the cabinet from the site and shift everything at the site into the antenna casing. For now, this is only possible for small base stations (femtos and picos) that have low output power. Imagining a 40W (46 dBm) macro RBS with no cabinet would be an earth-shattering achievement.

Node consolidation has been under consideration since 1970s and has been reckoned by several operators as a consequential solution for reducing both operational costs and energy consumption. Node consolidation is an arrangement to subtract the number of nodes and assemble the functionalities [26]. In fixed access networks, node consolidation is compassed by consolidating traditional service areas to larger service areas, served by larger central office sites. Generally, energy is the most essential "key performance indicator"(KPI) for majority of the operators. It is occasionally pointless trying to state anything about any other KPI without the knowledge of power availability KPI. Mathematically, energy reliability is inversely proportional to the amount of energy that is needed, i.e. energy efficient systems that consume small amount of energy are said to have high reliability and vice-versa. Lower energy consumption also means decreased CO2 footprint for the operator. This is an important area of interest for all the operators today as they have even made public commitments to get rid of greenhouse gas emissions. There is also an awareness among operators that governments will require greenhouse gas emissions to be reduced in the telecom sector. One recent example in this direction is that India's Department of Telecom has now introduced new rules that will oblige almost 50% of all mobile towers in the country to use some kind of renewable energy power by 2018.

The perhaps most interesting opportunity that comes from reducing RBS energy consumption is that it enables on site energy solutions. Today, providing voice and mobile broadband services from solar powered base stations is not feasible since that would require some 40-50 m² of solar panels. The size of solar panels needs to be reduced by a factor of 10 (down to 4 m²) and to do that a base station must be designed that consumes no more than 80W on average (assuming 1m² can produce 20W average power). The importance of this can not be

exaggerated. All future subscriber growth would happen in off-grid and bad-grid territory. With the RBS products that network equipment companies can offer today, mobile broadband in the form of LTE is not coming to off-grid areas in India and Africa any time soon.

1.2 Power Consumption in LTE

In LTE, the major traffic-independent consumer of downlink output power is the Cell Specific Reference Symbols, for which the two antennas utilize about 9% of the maximum configured output power. There are other traffic independent control channels that utilize 1-2% of the maximum configured output power. Positioning (PRS) utilizes output power depending upon the parameter settings meant for accuracy. The rest of the utilized output power is dependent on traffic and is consumed by Physical Downlink Shared Channel (PDSCH) and Physical Downlink Control Channel (PDCCH).

Since there are no performance(pm) counters for the utilized output power, other pm counters must be used to estimate the utilized output power. Nevertheless, in every case, it is important to understand the units of these pm counters. In LTE, the downlink output power is fixed per Resource Block; as the maximum configured output power divided by the total number of available Resource Blocks. Hence to estimate utilized output power for traffic, one method is to collect the pm counters for Resource Block utilization.

1.3 Background

The next-generation mobile networks are emerging in order to meet imminent needs pertaining to user experience and capacity. To accommodate the high traffic demand chiefly at indoor locations like office buildings, shopping malls, and train stations, indoor small cells complementing the existing macro cellular network are being deployed in large volumes. Concurrently, the energy efficiency of wireless networks has to a great extent become significantly important in the last few years. It, therefore, becomes de rigueur that these amplifying traffic demands should not amount to an increase in the energy consumption of the mobile network. Taking a glance at the energy required to operate a wireless mobile network, it is the base stations (BSs) that primarily contributes to the total consumption. Considering a mobile device, the major part of greenhouse-gas emissions during its life cycle comes from the manufacturing process. However, for a BS this is contradictory. Also, mobile devices are already today very energy efficient since they need to be battery operated without incessant charging. A breakdown of the energy consumption of mobile networks shows that 80% of the energy is consumed at the BS sites(reference). This justifies considering improvements in the BSs as the main contributors for a more energy efficient network. Heterogeneous networks (HetNets), consisting of several types of BSs e.g. indoor small cells, can improve both the coverage and capacity of a conventional macro cellular deployment. However, from an energy efficiency perspective they might perform poorly since a large

scale deployment of small cells together consume a substantial amount of energy. Additionally, small cells are not as predominantly accessed as a large cell, which suggests that for most of the time they would remain idle. Therefore, in order to improve the energy efficiency of HetNets, it is more prudent to allow small cells to enter a low-power sleep-mode during idle periods. This strategy is expected to save energy particularly at low system loads when the utilization of the small cells is also low.

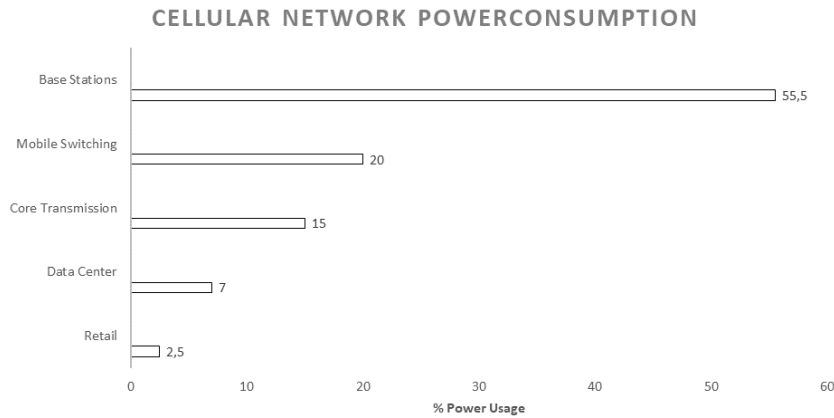

Figure 1.1: Power consumption of a typical wireless cellular network, source Vodafone

1.4 Motivation

Significant efforts have been made to curb or mitigate the perilous impacts of global warming as it threatens to raise the average temperature all over the world, causing dramatic changes in the economy and quality of life. Also, now there is consonance amongst the majority of the world’s population that action needs to be taken to abate the impact of global warming.

With the mushrooming of population and consequentially the economy, the demand for energy rises further. Government prognosis for the coming years bespeaks that much of that energy will come from fossil fuels, thereby aggravating the issue of global warming pollution [1]. Under such circumstances, attempts to reduce the contribution to global warming will be more arduous and uneconomic. Efficiency programs bring about ceaseless enhancements to base stations units and equipment that save energy, cutting down energy waste without downgrading lev-

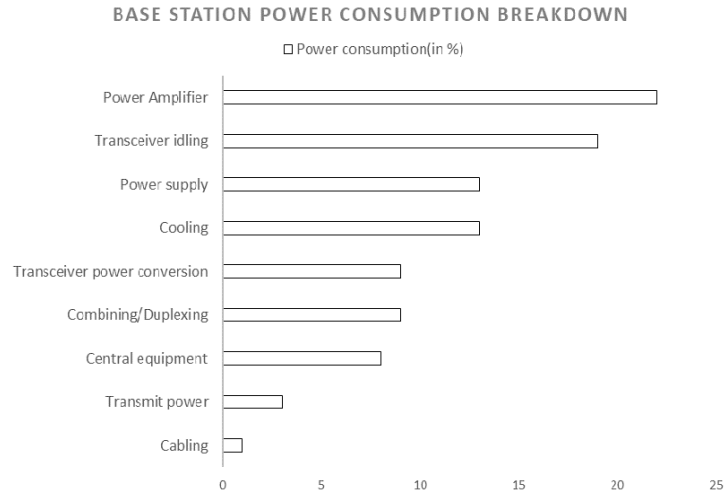

Figure 1.2: Base station power consumption breakdown (Globecom 2010, P.Grant and S.Fletcher, MVCE doc.O-GR-0053)

els of service. So an extensive grounding in energy efficiency is a sine qua non for putting a full stop to the adverse effects of greenhouse emissions. Therefore, it would not be wrong to hail energy efficiency as a pivotal component in docking global warming.

Energy efficiency would imply acquiring something more with less energy. Energy govern our lives as we rely on it in virtually every aspect. The ramification of our massive appetite for energy is that we demand more energy from our suppliers, the telecom providers who are then prompted to exploit more and more fossil fuels to a progressively increasing extent to keep up with the imposition. This suggests that we are now increasingly reliant upon resources that are not only limited but are also incredibly virulent, causing damaging effects to the environment and our health. The bottom line is that using an energy efficient system and harnessing renewable energy sources is the necessary ingredient to not only a cleaner and greener planet but also a way to cultivate a long term social and economic health. There are several ways to study and investigate the potential of energy efficiency, some of which could be: [2]

1. Technically possible measures- These are the plausible measures that includes all options notwithstanding any operational expenditure(OPEX) or capital expenditure(CAPEX)
2. Economical measures- These cover all options that are economically beneficial and bankable.
3. Achievable measures- Such initiatives take into advisement market and pub-

lic acceptance impediments that dictate how deeply economically sensible efficiency measures in the point above can actually penetrate society.

1.5 Problem Formulation and Method

Here, in this assignment it has been quite an endeavor to evaluate and further improve the energy efficiency of various heterogeneous network topologies in contrasting environments. The objective was to investigate how different network aspects such as deployment strategy and category of small cells affect the energy consumption of the network. Additionally, studies of how energy-saving technologies such as base station sleep modes and DTX could improve the energy efficiency was carried out. To study the behavior of dense urban and sub-urban LTE networks a static radio network simulation tool was used. The simulation scenario was a 3D city designed to capture the characteristics of a German city. The propagation models in the simulator took into consideration the multi-path propagation; explicit walls and floors in buildings. Besides, use of traffic models made it possible to determine areas with higher traffic demand (HotZones). However, to be able to measure the energy consumption of the simulated network, power models for the different base stations had to be implemented into the existing simulation framework. The energy savings from DTX was included as a statistical modification of the BS power models while longer sleep-mode periods were introduced by setting the transmit power to zero in the simulator. DTX and sleep modes were simulated for various heterogeneous network topologies for the sake of assessing and comparing the energy saving potential.

The objectives of the project can be underlined as:

1. Implementation of power models for different types of base stations into an already existing radio access network (RAN) simulation tool.
2. Evaluation of the energy efficiency of the considered heterogeneous network deployments through simulations using the implemented power models. The energy efficiency will be measured under various network loads. The considered network loads range from busy hours with peak traffic demands to off-peak hours with extended cycles of idle traffic.
3. To investigate how tuning the output power of the small cells affects the energy efficiency. With higher output power fewer small cells are needed since each cell covers a larger area.
4. To assess the attainable energy savings of technologies that aim to improve the energy efficiency, such as DTX and base station sleep modes. Of particular interest are periods of low user activity where the highest potential for energy savings is expected.

While this study only considers a German city’s simulation scenario, the implementations of the simulator allow for future studies of energy efficiency of LTE network deployments.

1.6 Outline of the Thesis

The structure of the following chapters are as follows: The second chapter deliberates in length about the previous work done in the same research area in order to have a fair idea about the current scenario and how this work is largely based upon that. Chapter '3' gives a brief idea about LTE and OFDM as the study focusses on LTE data only. In Chapter '4' a brief description on the basics of LTE HetNets with various types of indoor small cells is provided. For further understanding of energy savings from cell DTX, the downlink reference signals in LTE are exhibited. In Chapter '5' power consumption at BS level and various metrics for measuring energy consumption at network level are described. Also energy saving technologies are introduced with descriptions of how to model them in a simulation environment. Chapter '6' and Chapter '7' provide a detailed explanation of the traffic and power model adopted respectively. In Chapter '8' the results after implementing energy saving features are presented with comparisons, followed by discussion which is provided separately in Chapter '9'. Finally, in Chapter '10' conclusions are drawn and future work identified.

There have been several ongoing research projects that have contemplated the issue of energy efficiency of communication systems and its related components. Efforts have been made in strategies corresponding to various protocol layers of the wireless networks where the issue of energy conservation at all layers is addressed. Additional suggestive power savings can result from low power design within the physical layer and it has been elaborated in [7]. The physical layer can be broken down into components consisting of radio frequency(RF) circuits that include transmitters and receivers, modulation, and channel coding systems, intermediate devices like hubs, repeaters. From the perspective of energy efficiency, monumental preoccupation has already been given to the design of the physical layer. All the years behind energy efficient and low-power design research has predominantly revolved around this layer due to the fact that it is the system hardware that devours most of the power. The limitations in battery capacity is also a concern in wireless network. It would be unfair to say that very less progress has been made to save energy. On the contrary, the techniques evolved have brought about considerable energy savings, but other venues should also be explored to improve energy efficiency. One way to approach and pave way for future wireless networks is to chalk out a strategy to design the higher layers of the protocol stack with energy efficiency as an important goal [6].

Broadly categorizing the sources of power communication into two types, on the basis of network operations we have: communication related and computation related [6]. The former appertains to the usage of the transceiver at the source, intermediate (repeaters, if any), and destination nodes. The transmitter is used for sending control, routing request or response, as well as data packets that has originated from itself or has been routed from this transmitting node. The receiver then receives the data and control packets which might be destined for the receiving node and some of which are forwarded. The key lies in understanding the power characteristics of the mobile radio used in wireless devices designing an efficient communication protocol.

The computation related source of power communication is principally involved with protocol processing aspects. This would take into account the usage of the CPU and main memory and, to a certain extent, the disk and other auxiliary components. Many data compression techniques have also come up that

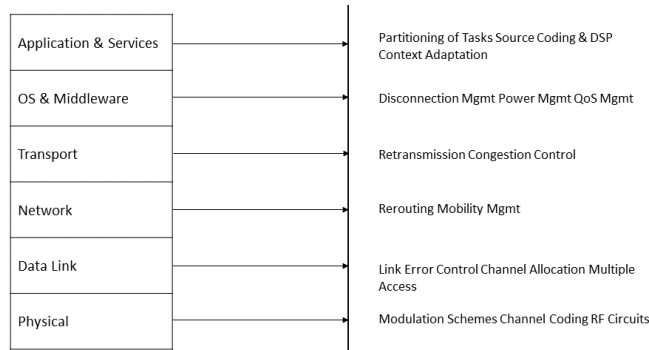

Figure 2.1: Protocol stack of wireless network

strive to reduce the packet length and in the process expends more energy. Overall, this may result in higher power consumption due to increased computation. The subtraction in packet length was a means to reduce communication costs but there now exists a potential trade-off between computation and communication energy consumption. So no matter the methodologies that strive to deliver lower communication, costs may result in higher computation necessities, and vice-versa. Hence, protocols that are being developed has to strike a balance between the two expenditures.

A network traffic can generally be classified into two categories: unicast traffic that is directed to a single node or multicast traffic addressed to multiple nodes. Broadcast traffic, can be defined as traffic in which packets are destined for all devices in the system. Compared to unicast and multicast traffic, broadcast traffic allows a greater volume of data packets flowing across a network at once causing more dissipation of energy. A single transmission is well enough for a mobile to broadcast a packet to all its immediate neighbors. Nonetheless, each mobile should receive a packet only once, and intermediate nodes are required to retransmit the packet. The conservation of energy can be made realizable by allowing each mobile’s radio to turn off after confirming a packet and making sure that its neighbors have already received a copy of the packet. The routing of broadcast traffic in terms of power consumption is further analyzed in [9].

The transport layer provides a transparent transfer of data to applications running at the end points of a network. It ensures reliable arrival of messages by providing error checking mechanisms. The most typically used transport protocol for wired networks, where we assume that the underlying physical links are moderately steadfast and the loss of packets are arbitrary in nature, is the

Transmission Control Protocol (TCP) [10]. Regardless, this cannot be said of a wireless network as the performance of conventional transport protocols, notably TCP degrades consequentially over a wireless link due to immanent wireless link properties. TCP and other transport protocols akin resort to a larger number of retransmissions and repeatedly invoke congestion control measures, stumped by wireless link errors and losses because of handoff and presuming it to be channel congestion. This can substantially reduce the throughput and broach unacceptable and unsatisfactory delays [11]. There are other versions of TCP such as Tahoe, Reno, and New Reno whose energy consumption is investigated in [12]. Here, the primary focus is given to energy consumption with the objective of discovering and evaluating the implication of the transmission policies that TCP bear on energy performance. The energy efficiency of a protocol can be represented as the mean number of successful transmissions per unit energy. Results of the study establish that the error correlation extensively affects the energy performance of TCP and that congestion control algorithms of TCP admittedly permit greater energy savings when error bursts are encountered by the process of backing off and waiting.

Another important research in the field of the energy efficiency was conducted by OPERANet (Optimising Power Efficiency in mobile RADio NETworks). The OPERA-Net was a European project whose main objective was to enable EU industry to undertake leadership in environmentally sustainable mobile networks [14]. It investigated all the opportunities open to improve the energy efficiency of cellular networks, especially the base stations considering the effective cooling and energy recovery. Focus was also given to optimization of the components used in communication systems. There has been a great uproar about power and energy savings within the wireless technology industry but it is not a new phenomenon. Taking the entire system altogether, a lot of energy is dissipated between each block, but the block that dissipates the most is the power amplifier (PA) which is a common knowledge. Saving power in a single PA amounts to saving many kilowatts at base station level, which finally results in saving gigawatts or terawatts at the country level.

Following the success of OPERA-Net, Thomson Broadcast announced its partnership with key participants to launch an unrestricted test site for hybrid energy 4G network that used renewable sources of energy. This was named “The Opera-Net 2” – Optimizing Power Efficiency in Mobile Radio Networks 2 [15]. The aim of the project was to reduce the ubiquitous environmental impact of mobile radio networks, compounding the previous OPERA-Net excellent results. The project started from the end of 2011 for a duration of 3 years and was sponsored by the French Ministry of Industry and the Finnish Funding Agency for Technology and Innovation – and involved many key industry makers, most of them from the former project such as Alcatel-Lucent Bell Labs, Alpha Technologies SA, Efore PLC, France Telecom, Freescale, Telecom Bretagne, Nokia Siemens Networks and Thomson Broadcast. This established platform was used to optimize energy consumption of the station and save energy up to 25%. Thomson Broadcast has been instrumental in the optimization of various components of the renewable energy, energy production, storage and also played its part to define an independent and

resilient measurement system used for various energy savings algorithm. All this has become attainable because of its profound expertise in energy efficient technologies for transmission applications. The evolved energy efficient solutions were executed in Lannion 4G station and it was believed that its performance may come through and contribute to the initiation of ‘green’ solutions in the standardization of cellular networks and provide the basis for supervenient cutthroat development for European industry [16].

Apart from these research projects, there are other notable ones like the PANAMA, ELBA [18] and Class-S [19] that generally focus on techniques of saving energy by ultra-efficient design of the power amplifiers in the communication systems as they are the major source of energy consumption and unfortunately they still run at quite low efficiency.

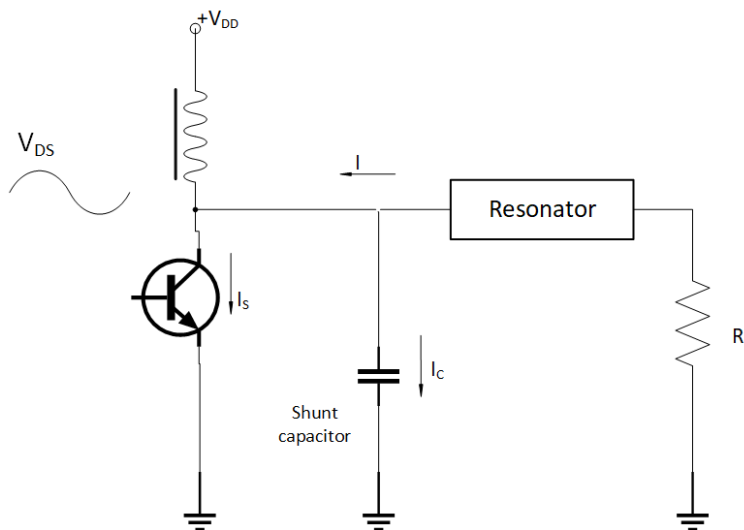

Figure 2.2: High efficiency PA used in PANAMA

The PANAMA project was an uncompromising and collective effort of leading European partners from different backgrounds and fields such as semiconductor, test tools, electronic design automation and academicians who had come together to attend to future’s importunate demands and concentrate on spawning extra efficient multi-band, multi-mode power amplifiers and transmitter systems. It is now a widely established fact that power amplifiers play a crucial role in the consummation of an indubitable mobile connected world as they have a sway on handset battery life, ownership costs with respect to cooling and electricity, spectral efficiency and systems co-existence. Also, a transvaluation of communications versatility and power efficiency adduces that the power amplifier is the most significant and decisive component of the communications nexus that requires novelty and innovation to achieve our objectives. However, a breakthrough in amplifier technologies needs to be considered in the pervasive context of the communications

system to secure veritable efficiency improvements, rather than merely relaying the problem from one side of the system to the other. This problem was addressed by the so-called CATRENE CA101 PANAMA project with a plan to sort out integrated systems, discrete systems and distributed systems in an attempt to apply it to a set of target applications such as 3G/4G and millimeter-wave mobile communications handsets and transceiver base stations, avionics, mobile satellite communications and home networking among other things. The foremost target was to attain efficiency gain of around 20% for integrated systems, 30% for discrete and at least 10% for distributed systems [17]. Outside of these goals, PANAMA relied on the development of fecund tools for the measurement, modelling and innovation in simulation areas to enable a quantum leap in design flow.

The purpose of the Leading Edge Cluster Cool Silicon was to mete out and administer the technological foundations to increase energy efficiency in the field of information and communication technology (ICT) monumentally. Fairly 45 projects have been realized by members of Cool Silicon. Cool Silicon intended to make some striking recommendations for high performance communication systems which would drain very less energy by focusing on the three main areas: micro and Nano technologies, broadband communication networks and wireless sensor networks [20]. The most exigent challenge in the field of micro- and Nano electronics is to control the massive increase in energy consumption. Still no noteworthy cluster has focused on the field of energy efficiency of the ICT. The Cool Silicon project focused on the reformation of individual aspects of the communication systems like the architecture of the system, communication algorithms and protocols along with the physical components that ranges from processors, graphic chips, controllers, sensors and mobile chips to name a few.

The term Green Radio has become a household name, widely used in ICT industry since it was coined by Mobile VCE Green Radio as early as 2007. [21] The project's objective was to improve the overall system efficiency studies by making use of an advanced energy metric for cellular communication. Specifically, the goal of this research was to guarantee a 100% reduction in energy requirements despite using high data rate services, in the process reducing CO₂ emissions and Opex costs. This ambitious goal of garnering a 100-fold reduction in power consumption was achieved without any compromise to the Quality of Service(QoS); in fact, efforts were made to even enhance the QoS. All the negative impacts to the deployment costs, equipment manufacturers and providers were also abated. It was digging into both optimum architectural and individual technological approaches. It was conceived that by moving the access network closer to the user allowed a reduction in the transmit power required. This retrenchment was achieved at the expense of jacked up backhaul requirements. The principal issues for cogitation were the sizes of base stations, backhaul method (that included wireless, fiber and free space optical), and potential use of femto-cell technologies. This optimum tradeoff managed to minimize the plenary energy usage. Multi-hop and mesh network architectures also had the eventuality to reduce energy consumption while maintaining QoS, particularly when there was an opportunity for data to be carried using low power (data showing tolerance to delay). But again, an increased

density of access devices also required an effective utilization of spectrum in order to guard that the overall interference drift is not degraded. One way to achieve energy efficiency is to check interference. A necessary ratio of signal to interference level at the receiver gives a preferred data throughput. If, somehow, this interference is clipped, the transmitted power level can also be reduced while still maintaining performance. Energy efficient hardware implementation of equipment belonging to the base station also aided in the reduction of total energy consumed in comparison to the radiated power. The equipment architecture and radio design technology that was perfected so as to provide efficient operation at high power and also when there was lower traffic demand made the project’s realization viable.

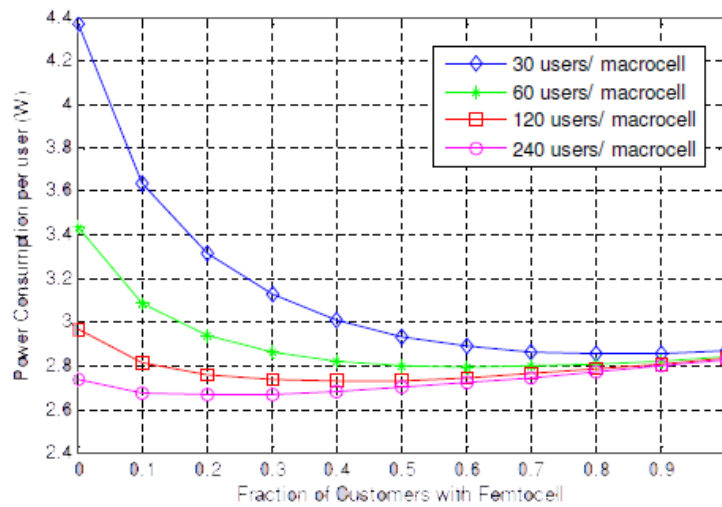

Figure 2.3: Power consumption per user for different levels of macro-cell support, Vodafone

However, there was no unified approach that existed to target the whole system from an energy efficiency perspective. Also little effort had been tendered to the efficiency of next generation wireless access systems (LTE systems). This gave rise to the EARTH project. The Energy Aware Radio and netWork technologies (EARTH) has been one of the crucial research project investigating the energy efficiency of mobile broadband networks since 2010. It was founded in 2010 with 15 partners from 10 countries whose main objective was to achieve a reduction of the overall energy consumption of mobile broadband networks by 50% [3]. But EARTH surpassed this pushing target by delivering Integrated Solutions allowing for savings in the range of 70% [4].

The EARTH project says that: “The goal of the project was to address the global environmental challenge by investigating and proposing effective mechanisms to drastically reduce energy wastage and improve energy efficiency of mobile broadband communication systems, without compromising users perceived quality of service and system capacity” [4]. EARTH regards both network aspects and in-

dividual radio components from a holistic point of view. As a part of the EARTH project, mathematical models for the power consumption of various BS types have been developed. These power models have been utilized in these simulations in order to study the energy consumption at network level. Several types of deployment areas, e.g. Rural, suburban, urban and dense urban were considered. Linear power models for BSs is widely used for simulation studies of energy efficiency and energy savings. Linear power models from the EARTH project are used in a generic 3rd generation partnership project (3GPP) simulation scenario where pico nodes are placed randomly within 100 m from each macro BS. Furthermore, the energy performance of LTE HetNets is studied in relation to the user experience by utilizing linear power models, again with a 3GPP simulation scenario different approaches to densifying urban networks are studied.

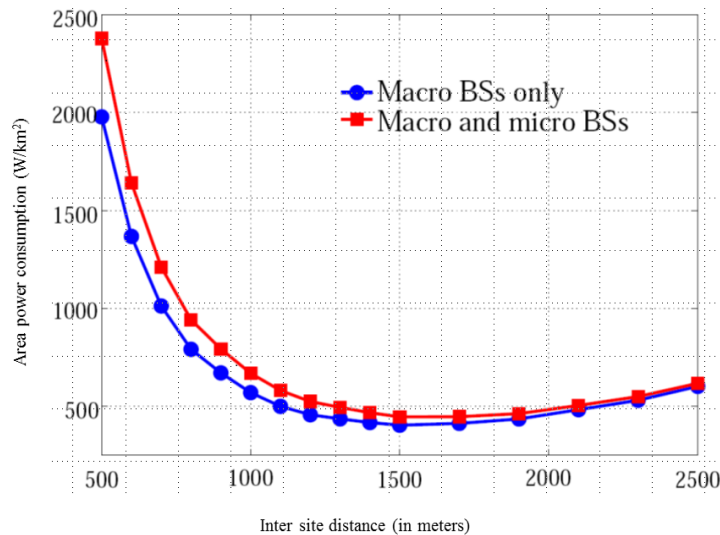

Figure 2.4: Area power consumption as function of inter site distance for different deployments

DTX as an energy saving technique is proposed in and the potential energy savings is studied in subsequent chapters. Also a DTX enabled macro deployment in a metropolitan area is studied through simulations. The main contribution from this study is an assessment of the energy saving potential from the combination of short term DTX sleep and longer sleep modes specifically in the small cell BSs. Furthermore, the studied simulation scenario is more specific and detailed than the previous work we know of, considering a city with real buildings and realistic small cell deployment. The realistic 3D environment and specific site deployment in the simulator allows for ray-tracing propagation models that is more accurate than statistical models used in generic scenarios with random deployment.

LTE stands for Long Term Evolution and it is evolved from the UMTS. From UMTS to LTE, plenty of changes are made to consider this new technological standard (i.e. LTE) evolutionary. To name some are, use of shared channels, better modulation scheme to support better data rate, reduced latency, simplified network architecture, backward compatibility with UMTS etc. The support for packet-switching (PS) mode can be regarded as one of its most distinctive features. Hence, all traffic flows including real-time service with a rigid delay requirement such as voice services are provided in the PS domain in a unified manner. The target peak data rate is 300 Mbps in the DL and 75 Mbps in the UL, respectively. The LTE Rel. 8 supports scalable multiple transmission bandwidths as well including 1.4, 3, 5, 10, 15, and 20 MHz. LTE is also being further evolved to LTE Release 9 which support some emergency services as well as LTE Release 10 or say LTE Advanced. In LTE Advanced, by combining multiple frequency blocks of bandwidths supported by LTE Rel. 8, wider bandwidths are encouraged, and are called Component Carriers (CC). This technology is called Carrier Aggregation (CA).

3.1 Downlink Frame Structure

It's quite fascinating how data travels in physical layer, in LTE. In-order to understand it, understanding of frame structure is extremely important. Downlink and uplink transmissions in LTE are organized into radio frames. Two radio frame structures are supported:

1. Type 1, applicable to FDD.
2. Type 2, applicable to TDD.

From 3GPP specification 36.211, FDD LTE frame structure (which is Type 1) is as follows. It only shows the structure of one frame in time domain, Figure 3.1 doesn't tell anything, how it would look like in frequency domain: [29]

The following are the high level observations that could be made if an effort is taken to read the diagram.

1. Time duration for one frame (One radio/system frame) is 10 ms. So in one second, we get $1000/10 = 100$ radio frames.

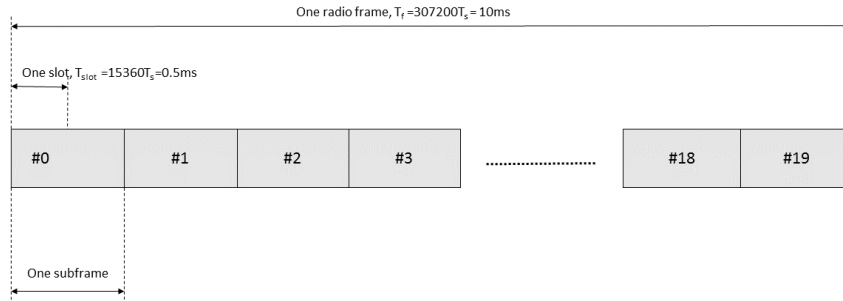

Figure 3.1: Type 1 LTE Frame Structure.

2. The total number of samples in each frame (10 ms) is 307200 (307.200 K) samples. This implies that the number of samples we get per second is $307200 \times 100 = 30.72 \text{ M}$.
3. There are 10 sub-frames in one frame.
4. Every sub-frame has 2 slots. So, within one frame we have 20 slots. Slot is not the smallest component in time domain of FDD LTE Frame. If it is magnified further, one slot is made up of 7 small blocks called 'symbol'. Even smaller structures within a symbol called 'Cyclic Prefix' exist and is present in the beginning of every symbol.

When the LTE FDD frame structure is expanded in frequency domain, a lot of subcarriers or channels are found. By taking smallest unit in time domain i.e. symbol and smallest unit in frequency domain i.e. subcarrier, the smallest unit in two-dimensional frequency/time space is obtained also called Resource Element. One slot in time domain and 12 sub-carriers in frequency domain together constitute a Resource Block. Resource Block (RB) is the most crucial unit in LTE both for protocol side and RF measurement side [27], [28].

From 3GPP specification 36.211, TDD LTE frame structure (which is Type 2) looks like in figure 3.2.

On observing the type 2 frame structure, it can be seen from the very outlook that, length $T_s = 307200.T_s = 10\text{ms}$ consists of two half-frames of length 153600. $T_s = 5\text{ms}$ each. Each half-frame consists of five sub-frames of length 1 ms. The supported uplink-downlink configurations are listed in below table where, "D" denotes the sub-frame is reserved for downlink

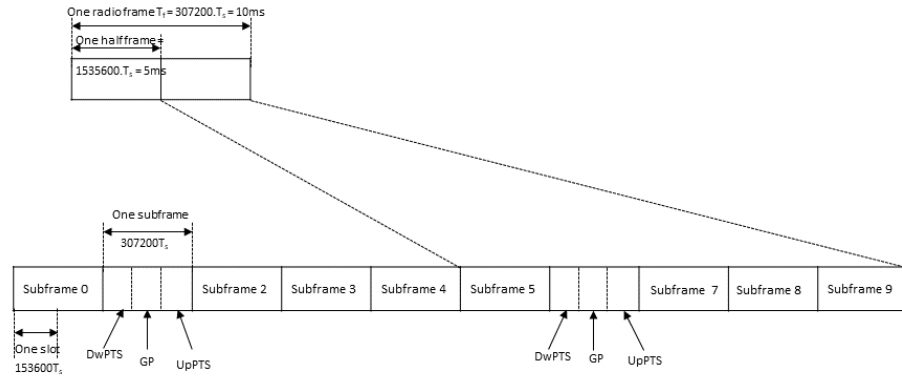

Figure 3.2: Type 2 LTE Frame Structure.

transmissions, “U” denotes the sub-frame is reserved for uplink transmissions and “S” denotes a special sub-frame with the three fields DwPTS, GP and UpPTS.

Uplink-downlink configuration	Downlink-to-Uplink	Subframe number									
		0	1	2	3	4	5	6	7	8	9
0	5ms	D	S	U	U	U	D	S	U	U	U
1	5ms	D	S	U	U	D	D	S	U	U	D
2	5ms	D	S	U	D	D	D	S	U	D	D
3	10ms	D	S	U	U	U	D	D	D	D	D
4	10ms	D	S	U	U	D	D	D	D	D	D
5	10ms	D	S	U	D	D	D	D	D	D	D
6	5ms	D	S	U	U	U	D	S	U	U	D

Figure 3.3: Uplink-downlink configuration.

3.2 Uplink Frame Structure

In LTE, uplink frame-structure is more or less same as discussed above. In FDD, it’s same as DL and in TDD, one could see the frame structure which was discussed for DL and can find sub-frames being used for uplink. Though the resource blocks and elements have already been discussed, it’s apt only to have a look to the following diagram of resource grid and strengthen the understanding of frame structure.

An uplink physical channel corresponds to a set of resource elements carrying information are PRACH,PUSCH, PUCCH.[29]

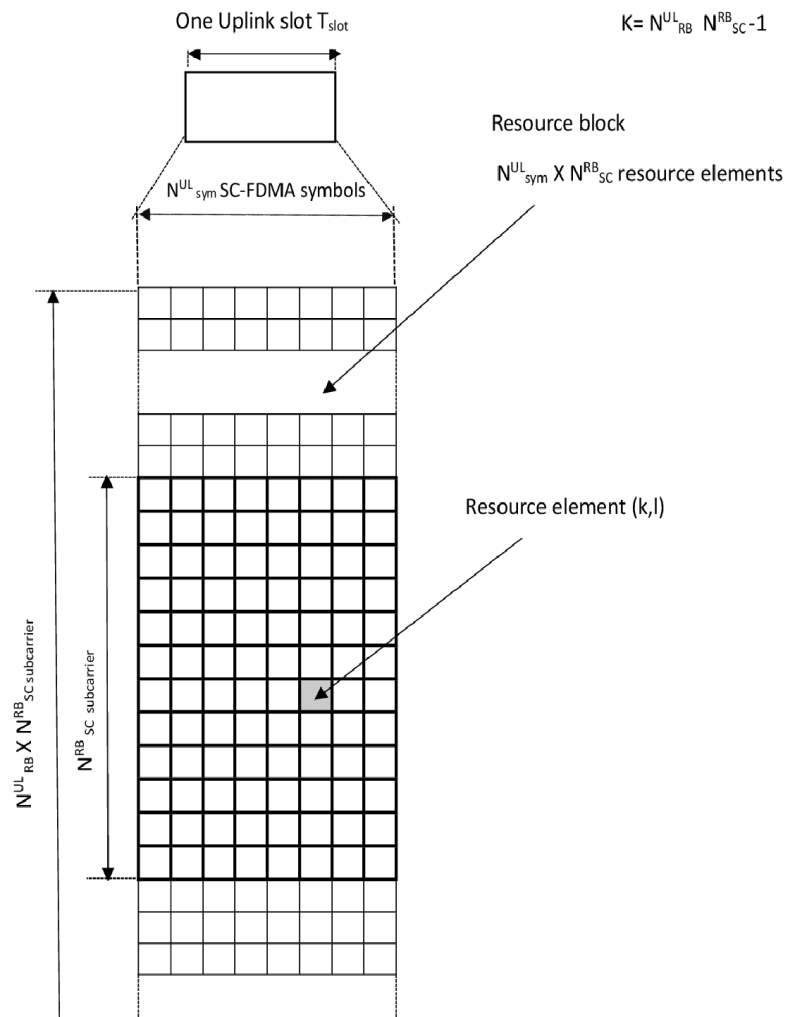

Figure 3.4: Uplink frame structure.

3.3 Orthogonal Frequency Division Multiple Access(OFDMA)

OFDMA is a form of OFDM, which is the underlying technology. Long Term Evolution (LTE) is an OFDMA-based technology standardized in 3GPP Release 8 and Release 9. The difference between OFDM and OFDMA is that OFDMA has the ability to dynamically assign a subset of those subcarriers to individual users, making this the multi-user version of OFDM, using either Time Division Multiple Access (TDMA) (separate time frames) or Frequency Division Multiple Access (FDMA)(separate channels) for multiple users. [30].

OFDM is a form of multi-carrier modulation. An OFDM signal normally comprises of a number of relatively closed spaced modulated carriers. When modulation of one kind, which could be - voice, data, etc. is laid on a carrier, then the sidebands sprawl out on either side. Then it becomes absolutely obligatory for a receiver to be able to receive the complete signal in order to successfully demodulate the data. As a result, when signals are transmitted close to one another they must maintain a gap so that the receiver can separate them with the aid of a filter and there must also be a guard band between them, but, with OFDM this is not a mandate. Although the sidebands from each carrier overlap, they can still be received without the interference that might be definitely expected because they are orthogonal to each another. This can be performed by keeping the carrier spacing equal to the reciprocal of the symbol period [28].

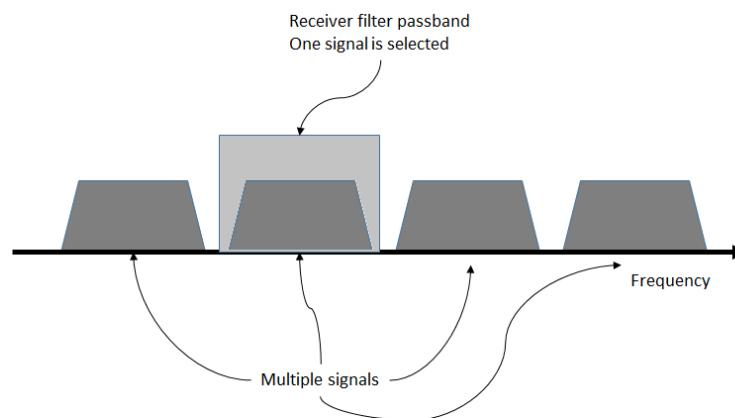

Figure 3.5: OFDM a form of multicarrier modulation.

To know and grasp how OFDM really functions, it is necessary to consider the receiver. The receiver can be interpreted as a bank of demodulators, that translates each carrier down to DC. The resulting signal is then integrated over the symbol period to regenerate the data from that carrier [27]. The same demodulator also demodulates the other carriers. As the carrier spacing is equal to the reciprocal

of the symbol period it eventually means that there will have a whole number of cycles in the symbol period and their contribution will sum to zero – in other words there is no interference contribution.

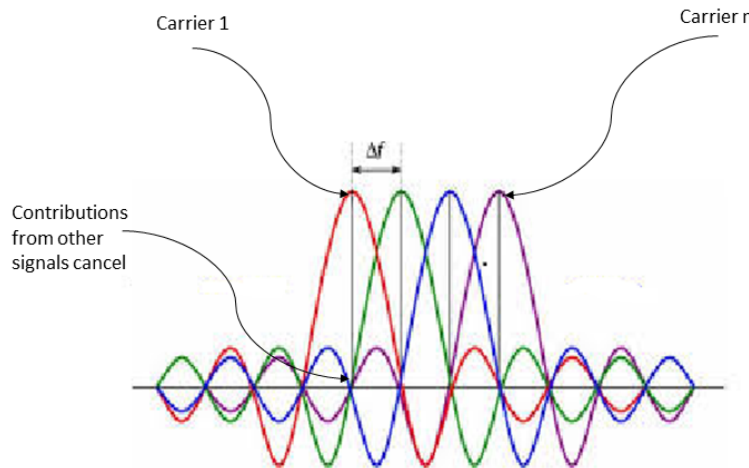

Figure 3.6: OFDM- orthogonality.

The data which needs to be transmitted on an OFDM signal is spread across the carriers of the signal, each carrier taking part of the payload. This reduces the data rate taken by each carrier. The reason behind using the lower data rate is that it has the advantage that interference from reflections is much less critical. This is done by adding a guard band time or guard interval into the system which ensures that the data is only sampled when the signal is stable and no new delayed signals arrive that would alter the timing and phase of the signal.

OFDMA looks relatively straightforward but despite that, it has very attractive benefits. Probably the most important of these is its immunity to selective fading. It is more resistant to frequency selective fading than single carrier systems because in OFDMA the overall channel is divided into multiple narrowband signals that are affected individually as flat fading sub-channels. It is more resilient to interference. Interference appearing on a channel may be bandwidth limited and in this way will not affect all the sub-channels. This means that not all the data is lost. Using close-spaced overlapping sub-carriers, a significant OFDM advantage is that it makes efficient use of the available spectrum. OFDM tends to be very resilient to inter-symbol and inter-frame interference also. This payoff is from the low data rate on each of the sub-channels. A legitimate application of adequate channel coding and interleaving makes it largely possible to recover symbols lost due to the channel’s frequency selectivity and narrow band interference. This is how prevention of data being lost is carried out. Earlier in CDMA systems,

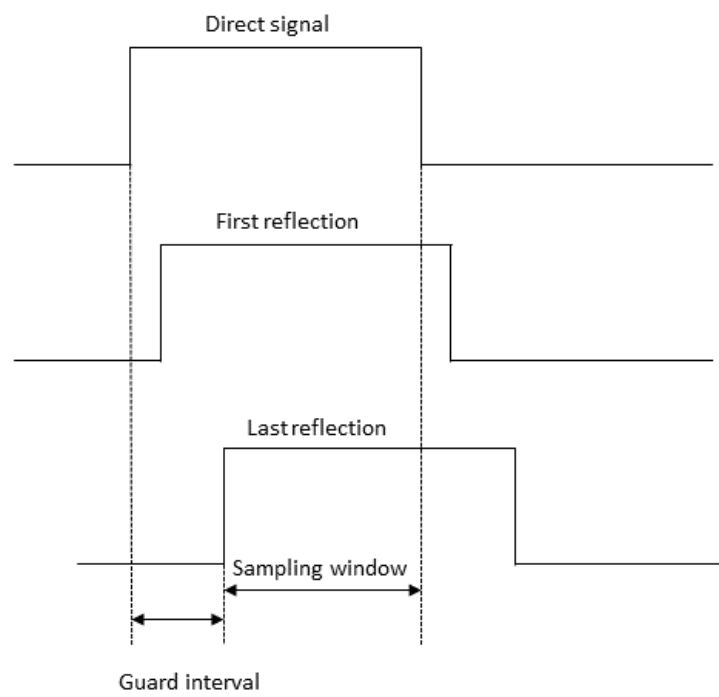

Figure 3.7: OFDM-immunity to selective fading.

there was this complexity issue with channel equalization which affected the whole channel but now, with OFDM this issue has been resolved as OFDM makes use of multiple sub-channels, and hence makes the channel equalization much more simpler.

3.4 OFDM Cyclic Prefix

The use of cyclic prefix is a key element to enable the OFDM signal to operate reliably. The cyclic prefix acts as a buffer region and is generally regarded as a guard interval to safeguard the OFDM signals from intersymbol interference. This can be a concern in some circumstances despite applying the much lower data rates that are transmitted in the multicarrier OFDM signal.

The cyclic prefix is constructed such that each OFDM symbol is preceded by a copy of the end part of that same symbol. Different OFDM cyclic prefix lengths are present in various systems. For example, two sets of length available within LTE are a normal length and an extended length and after LTE Release 8, a third type called the extended length is also now included. The inclusion of the cyclic prefix grants robustness to the OFDM signal. The data that is retransmitted can be used if required. The guard interval introduced by the cyclic prefix thwarts the adverse effects of inter-symbol interference by reducing it significantly. Like, the saying goes "win some, lose some" cyclic prefix comes with its drawbacks as well. When the cyclic prefix re-transmits data that had been transmitted earlier, it feeds on the system capacity and lowers the overall data rate.

3.5 MIMO (Multiple Input Multiple Output)

Simply put, it is another of the LTE major technology innovations used to increase the data throughput by using multiple transmitter antennas and multiple receiver antennas by the use of OFDM. Two major limitations in communications channels can be multipath interference, and the data throughput limitations as a result of Shannon's Law which defines the theoretical maximum rate at which error free data can be transmitted. MIMO provides a way of exploiting the multiple signal paths that prevails between a transmitter and receiver to significantly enhance the data throughput available on a given channel without altering the specified bandwidth. By making use of multiple antennas at the transmitter and receiver along with some byzantine digital signal processing, MIMO technology enables the system to assemble multiple data streams on the same channel, and thereby increasing the capacity of a channel.

MIMO also avails the transmission technique of Spatial multiplexing to transmit independent and separately encoded data signals from each of the multiple transmit antennas while reusing or multiplexing in the space dimension. These independent data signals are known as spatial streams. The transmitting antenna mobilises multiple radio Tx chains and signal paths to simultaneously transmit different data streams, while the receiver combines the Rx signals resulting in

higher throughput. By increasing the number of receive and transmit antennas, the throughput of the channel increases linearly resulting in high spectral efficiency.

Heterogeneous Network

4.1 Summary

Heterogeneous network deployment has become an omphalos in the radio access network so in this section, emphasis is given to the changes brought by such a heterogeneous network. This deployment consists of base stations and its associated infrastructure which is a synthesis of macro cells, micro cells and small cells.

The traffic levels and end-user expectations regarding data rates and latency have been rising proportionately. Watching, streaming videos, uploading pictures on Instagram or using cloud-based services establishes extreme demands on mobile networks. There is also a need to connect more devices at the same time. This has been the driving force behind the constant network change. These demands can be addressed by using the so called heterogeneous networks toolbox – improve macro, densify macro and add small cells. This enables operators to keep their mobile broadband access provisions versatile despite constant evolution, dimensioning and optimization of the network.

4.1.1 Solution to Traffic Demands

The growing traffic demands can be to a certain extent pacified by the solutions below.

1. **Macro Improvement**

There is a likelihood to garner a 10-fold capacity gain by just revamping the existing HSPA macro networks with accessible technology. The technology would comprise of:

- (a) the addition of new spectrum,
- (b) Refarming low spectrum bands,
- (c) Adding LTE and
- (d) Deploying a combination of antenna-centric and RAN performance features such as higher-order modulation, higher sectorization, and multi-carrier and multi-antenna solutions.

Improving HSPA alone guarantees a 2–4-fold capacity gain.

2. Densification of Macro

Apart from improving the macro network, there exists another strategy that improves the capacity. This arrangement is called ‘Densification’ obtained through the deployment of flexible base station products with reduced site requirements, such as antenna integrated radio (AIR). An advanced macro networks, nowadays, can have an inter-site distance of less than 200 meters, compared with the 700 meters, a characteristic of less dense urban networks. This comports to a 12-fold capacity difference, which would be very challenging to accomplish through the deployment of small cells alone.

3. Addition of coordinated small cells

Operators can add coordinated small cells wherever needed from a capacity and coverage perspective, and where feasible from site and backhaul viewpoints –ideally where users tend to consume most macro cell resources in order to gain maximum boost in overall performance.

4.1.2 Small cell deployment scenarios

It is of paramount importance to have radio solutions tailor-made for various deployment scenarios. In dense urban regions, like city streets and squares, outdoor micro cells are more appealing, as they have sufficient power both to cover a considerable outdoor area and reach indoor users on lower floors of buildings, which aids in offloading indoor users from the macro network. A macro cell is always deployed for coverage if not mentioned explicitly. In cases where the improvement needs are distributed and no apparent target buildings for indoor systems are present, a selective outdoor micro cell deployment proffers a cost-efficient small cell solution for an improved overall network performance. If there is an availability of fibre, the option to deploy micro remote radio units (mRRUs) is also a viable option, otherwise VDSL2 over telephony copper or microwave non-line of sight (NLOS) backhaul may be engaged to serve complete micro base stations (mRBS).

For small indoor hotspots such as cafés, where standalone Wi-Fi is often already installed which would be an assumption here (and so sites are available), operators can deploy indoor pico base stations (pRBS), congruous with the available fixed broadband. If desired, the stand-alone Wi-Fi can be superseded by carrier-grade Wi-Fi integrated both physically and logically into the pico base station and mobile broadband network for a better end-user experience.

In certain in-building scenarios – which could be anything from stadiums, shopping malls, to train stations, airports or offices – dedicated in-building solutions are generally required to meet native capacity and end-user data rate needs, or it might be for generating revenue potential from premium services, all for business expansion. A cocktail of cell types can be exercised, depending on the nature of the building and on the backhaul accessibility. Fibre cables habilitate the use of RRUs, while pico base stations can be deployed in conjunction with VDSL2 over Category 5/6 Ethernet cable or telephony copper. Distributed antenna system (DAS) infrastructure may be reused, where available, by deploying a pico cell every floor, each driving a floor-level portion of the DAS, so delivering a cell-splitting

gain. The original DAS system functionality may also be retained to expedite continued basic multi-operator coverage.

4.1.3 Traffic Expansion

According to the latest reports furnished by Ericsson Mobility, the global smart phone users are spawning. Not only that, the average data traffic generated by mobile broadband devices is expected to increase four-fold in the coming four- five years. At the same time the number of subscribers is also estimated to increase at least three times, resulting in an overwhelming 12-fold increase in global mobile broadband traffic over this period. To be more specific, in dense cities, where challenges in traffic are most pronounced turning it into a quagmire, i.e. subscriber penetration is at its peak, the most contributing factors to traffic growth are increased number of rapacious devices craving for more data, growing data consumption per device, and urbanization.

4.1.4 Futuristic data rates

The rationale behind the continued growth of end-user expectations of data rates and coverage is the full-fledged pace of innovation in the device and application industry. Presently, mobile broadband users roughly expect widespread coverage with download speeds of at least 1 Mbps, and typically 10 Mbps. It is difficult to imagine their expectations five years down the line. Looking at the trend, download speeds of 5–10 Mbps sound like a reasonable assumption.

4.1.5 Urbanization

By 2018, more than 30 percent of the world’s population is expected to live in metro and urban areas making the lines of demarcation between urban and suburban rather blurry. Although these areas portray less than one percent of the Earth’s land area, it is presumed that they would generate almost 60 percent of mobile traffic by 2018.

4.1.6 Make the Right Choice(Heterogeneous Network)

The term mobile broadband is very extensive and has a very intricate design but it can be loosely considered as something that provides an immaculate user experience for smartphones and mobile broadband services – inclusive of both static and moving users. To meet the demand and competition, it is essential to expand capacity and coverage in a svelte, cost-effective way. The most decisive way to improve network performance involves a combination of improving and densifying the macro cellular layer for general coverage and capacity, and adding small cells in strategic places. Improving the prevalent macro cell sites requires spreading out more spectrum, utilize advanced antennas, high-order diversity on the receiver and the transmitter, and greater baseband processing capacity within and between nodes. Continued evolution of HSPA and LTE technology will eventually whirl macro network efficiency through specialized features [32], such

as higher-order modulation, higher sectorization, multi-carrier and multi-antenna solutions, as well as spectrum refarming using hybrid radio solutions. Increasing capacity and data rates in this way minimizes the need for new sites. Densification of macro network suggests the addition of (smaller) cells to improve capacity and data rates at strategic locations, particularly when there is no further gumption to continue improving the macro network to meet demands alone. This approach keeps the total number of sites relatively low, while network performance becomes less sensitive to traffic location.

Adding small cells involves supplementing macro cells with micro cells, pico cells, as well as dedicated indoor solutions. It delivers phenomenal per-user capacity and rate coverage in high-traffic areas, with the potential to bolster performance in the macro network by offloading traffic generated in hotspots. The overall network performance utterly depends on the degree of integration and coordination that can be achieved throughout the heterogeneous network.

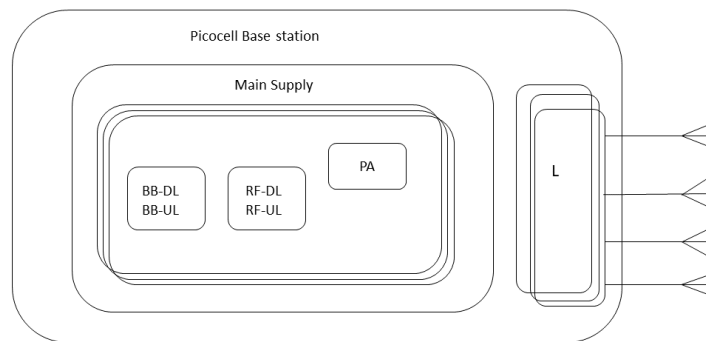

Figure 4.1: pico-cell basestation

4.1.7 Small cells making strides in metropolitan areas

The network in totality needs different solutions to meet the varying and unsettling capacity demand. In rural areas, the challenge is to provide cost-efficient coverage for mobile broadband services, while also maintaining good end-user experience. Improving the macro layer is by far the most cost-efficient way to address this challenge in less populated areas. In suburban and low-rise urban areas, there is a need to improve and densify the macro network, especially to meet increasing demand for higher data rates. The large coverage area of macro cells means they are often a more cost-effective way to meet these demands than deploying small cells in abundance.

In dense urban and urban areas, in addition to improving and adding macro cells, small cells offer a cost-effective complement in traffic hot-spots, for coverage discontinuities and in certain buildings. Attention must be brought to the fact that localized (in-building) solutions are applicable throughout the network to serve premium customers with high willingness to pay, for example at enterprises and airports.

In urban and dense urban areas especially, there is a compounding need to improve user experience and network coverage and capacity through heterogeneous network solutions. The complete transformation of macro cellular network into a heterogeneous network will be dictated by a combination of the operator’s mobile broadband strategy and existing network infrastructure; competition from other mobile and fixed broadband operators, as well as spectrum; site and back-haul availability. Flexibility and a strategic network evolution path are needed to ensure that customer expectations are met in the most cost effective, spectral-efficient and future-proof way. Different solutions will be needed for miscellaneous situations, for example:

1. small macro cells or micro cells would be cost-effective in a city environment to improve general indoor coverage.
2. small remote radio units could be used at a train station or stadium for maximum performance pico cells or a sectorized (cell split) distributed antenna
3. system fed by small remote radio units would be a natural solution for an office environment.

4.2 Improve Macro

Sites are a critical cost driver in mobile networks. Ergo, in most cases, improving coverage and capacity delivered at already available sites is the most cost-effective way to strengthen overall coverage and capacity. In addition, these improvements can be completed in a short time compared to the idea of acquiring and building new sites. This is why improving existing macro sites is a key tool throughout the network, and should always be considered first. Only when macro improvement has been exhausted as a way of addressing the coverage or capacity predicament should macro densification and small cells be used. In particular, improving macro cells is a key tool if there are general coverage issues, with no major traffic hot-spots, or to improve data rates in hot-spots near an existing macro site.

Improving the macro cells can be achieved through any available method that can be used on existing macro sites, which fall into three main categories: adding spectrum, improving radio/antennas and performance features for increasing efficiency.

4.2.1 Spectrum Augmentation

Adding spectrum is the most effective way to improve capacity. It can involve adding new carriers or new low-frequency bands, as well as adding technologies such as LTE and Wi-Fi in previously unused bands.

4.2.2 Develop radio/antennas

By integrating the antenna and radio chain, the link budget can be improved in both uplink and downlink, which improves overall system capacity. Adding more antennas and radios to the cells enable functions such as four-way receiver diversity and multiple input, multiple output (MIMO). With more radios and antennas, it is also possible to increase sectorization, re-engineering three-sector sites to six-sector ones for example.

4.2.3 Performance features

With new software features coming up in WCDMA and LTE radio access networks, capacity can be greatly improved. This makes it imperative to keep the radio access network software on the latest release, and that all relevant features are activated in order to deliver the best-possible capacity and end-user experience. These capacity features incorporate load sharing, multi-carrier / carrier aggregation, advanced receivers and radio resource management schemes.

Improving macro baseline performance offers very high potential for capacity enhancement and, if capitalised conclusively, can often increase capacity ten-fold in the short term. The key steps involve improving HSPA, introducing low-frequency bands, and deploying LTE (including new spectrum). In practice, the capacity increase realized through new air interface technologies are limited by the availability of advanced terminals that can make use of the technologies; for instance, the availability of HSPA 42 Mbps or LTE-capable terminals. While modernizing the entire terminal fleet may seem onerous, it can be achieved relatively quickly compared with the task of finding new sites in a congested area. Moreover, advanced terminals often have more efficient receivers, which significantly increase overall performance. It is therefore important to consider all possible improvements to the existing site grid, since the combined effect of adding HSPA features, HSPA spectrum and LTE is very powerful.

4.2.4 Capacity Boost- Turbo Mode

Taking into account, the potential to improve an existing HSPA network, capacity can be defined as the maximum served traffic per unit area, assuming that 95 percent of users get at least 1 Mbps data rate on the downlink. The starting point is a basic HSPA 21 Mbps capable system, operating in 20 MHz of spectrum (four carriers, each of 5 MHz) in the 2.1 GHz band. As a first step, the HSPA system is modernized with multicarrier, MIMO, and the latest smartphone efficiency, receiver and radio resource management features (supported on the Ericsson DUW platform). Evolving HSPA in this way can increase capacity more than four-fold.

The second step involves adding a low-band HSPA carrier. This increases capacity by approximately 20 percent, while also increasing user data rates at cell edges, especially indoors. Third, an LTE 20 MHz system operating on the 2.6 GHz band is added. This adds valuable capacity as well as high peak rates, and provides a platform for further expansion.

Using low-band spectrum is already proving to be an important way to improve macro cell coverage and capacity. Although the main driver for low-band mobile broadband is perhaps to provide basic coverage in rural areas, it also offers significant benefits in urban areas. For example, indoor data rates – at the macro cell edge – are often limited by signal strength rather than by interference. Furthermore, as path losses increase with carrier frequency, and most HSPA mobile broadband networks operate at 2.1 GHz, there is a great potential to improve indoor/cell edge data rates by using low-band spectrum.

Other advantages of low-band mobile broadband (whether HSPA or LTE) include:

1. Higher capacity, as cell edge users occupy the system for shorter times and consume fewer resources
2. Fewer dropped calls, thanks to improved coverage and fewer inter-RAT handovers

One of the key ways to improve indoor coverage, especially in sparse macro layers, is the link budget, or maximum supported path loss. Integrating the antenna and radio unit, including transmitter and receiver, in a single enclosure, as in antenna integrated radio (AIR) product, improves radio frequency (RF) performance significantly by reducing internal losses.

4.3 Densify Macro

Urban and suburban mobile networks have undergone major change over the past two decades. Though, originally designed for voice coverage, these networks have been successively densified with an increasing number of macro cells to meet ever-growing demand for better coverage and higher capacity. Initially deployed on the top of the highest buildings to reach as far as possible, macro cells are now generally placed on low rooftop masts with substantial down-tilt, or even below rooftops, in order to limit interference with neighbouring cells.

A dense macro network provides very good capacity and coverage, but the term ‘dense’ is truly vague and differs according to the precinct. In many North American cities, the macro inter-site distance (ISD) is in the 700–800 meter range, while at the other extreme, megacities in Korea and Japan have ISDs in the order of 200–300 meters. Regardless of today’s macro densities, further densification continues to be efficient down to ISDs of around 150 meters. Below that, the additional gain per added macro site starts to decrease as a result of higher levels of inter-cell interference. At this point, further capacity increases can be achieved

by adding small cells, either outdoors at street level or indoors.

Fig 4.2 is a simulated network map of the German city under test where the capacity(surrounding macro) and coverage cells(center macro) are deployed. The red spots corresponds to the hot zones where the users are heavily concentrated.

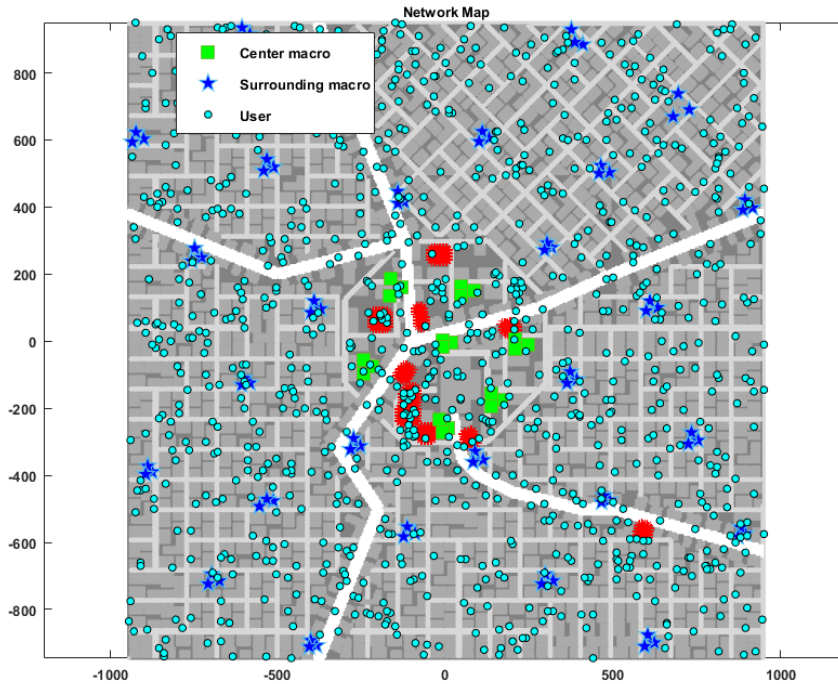

Figure 4.2: Network Map

4.3.1 Dense-urban region

A recent venture has been to validate the plans to densify an already dense macro network in an urban area of an east Asian city, and to deploy LTE.

A typical dense urban region has an inter-site distance of 250 meters with a high user throughput, especially outdoors, but some areas can be seen to have relatively low user throughput and poor indoor coverage. For example, there could be an overloaded cell, resulting from a combination of high uptake and poor coverage which drives utilization and increases queuing. Network performance has been evaluated for a target user data rate of 0.5 Mbps and, for this network, only 80 percent of users exceeded this data rate. The macro densification can be used to offload the congested macro cells and improve indoor coverage. The simulation results show that the proportion of users exceeding the 0.5 Mbps target has increased to 95 percent. The improvement resulting from the additional macro

sites can also be expressed as a 150 percent increase in network capacity, when regulating the load to keep the ‘satisfied user’ level constant at 90 percent in both cases. The conclusion is that a selective densification of even already-dense networks can greatly improve network performance.

4.3.2 Sub-urban region

Macro cellular networks cover suburban environments efficiently, as most buildings are relatively low and macro sites are typically located significantly above rooftop level. This means that compared with dense urban environments, where buildings are higher and have a larger footprint, suburban building penetration losses are lower and most buildings have a line of sight connection to their serving macro cell. Moreover, inter-site distances between macro sites are substantially higher than in crowded urban areas. Suburban cellular networks can therefore be efficiently evolved through both higher-order sectorization and the addition of macro sites.

The merits of macro densification were studied in a north American suburb in order to validate the performance gains. The baseline macro network is served by 13 macro cells with 2–3 km inter-site distance. Antenna height ranges from 25 to 45 meters, and antenna tilt angles are between two and seven degrees. Most buildings are 1–2 stories high and 10 percent of the area is covered by buildings. Seventy percent of all subscribers are located indoors. The simulated network used LTE with 2x2 MIMO, on 10 MHz in the 700 MHz band. Traffic load in the uplink was set to 0.8 GB per user per month, with all subscribers in the area concentrated on this LTE band. Assuming an annual traffic growth of 50 percent from the 2012 actual level, and that in reality subscribers also use other operator frequency bands, the simulated load situation corresponds to a real-life situation in 2018 or beyond.

Indoor users suffer from poorer performance than outdoor users, due to the transmission power constraints of the mobile terminals. There can be improvement in uplink bit rates following the deployment of two additional macro sites, which corresponds to a capacity increase of 46%. The placement of the additional macro sites has been determined based on the highest path loss towards the strongest macro site. The performance in terms of achievable bit rates is substantially boosted by the densified macro network. The number of satisfied users in the densified network increases from 62% to 93%. For comparison, if the existing baseline macro network is complemented by 20 small cells of 2 x 1 W output power, the number of satisfied users would only improve by less than one percent.

There has been a remarkable swing in the current macro cell deployment and the focus has shifted from integrated macro base stations to main remote solutions, where the radio unit is situated close to the antenna. This results in greater flexibility in installing the base station equipment. But, the drawback is the standard remote radio unit (RRU) deployment increases mast-mounted weight, volume, wind load and requires more visual impact, which in turn renders site acquisition arduous if tower space is limited.

A new product designed to neutralize all the mentioned downsides is the antenna-integrated radio(AIR) which is a fully integrated radio frequency(RF) front-end that consists of an air interface at the rear. The AIR is approximately the same size of an ordinary stand-alone antenna, maybe slightly heavier than an RRU. Nonetheless, the combined weight of the tower-mounted equipment is considerably lower. The operational expenses incurred in a macro cell densification is also reduced by AIR, thanks to an easy and a much improved installation which contributes to an effective combination of antenna and radio units into a single unit. Combining RF and antenna equipment in this manner demounts a key barrier to densification.

In Germany, it has been made possible to replace one passive antenna and two RRUs with a single AIR unit to enable macro cell densification which brought down the annual rent by €1300.

4.4 Addition of Small Cells

In the drive to evolve mobile broadband capacity and user experience, improving and densifying the macro network is sometimes not enough. In cities in particular, capacity demand per unit area is growing rapidly, as are user expectations for high and consistent data rate coverage.

Today we see leading multi-standard mobile broadband networks with macro cell inter-site distances down to 150 meters or less. Performance in these networks will be evolved through macro improvement and densification where possible. In some localized areas, additional tools are needed to further boost performance in order to secure excellent, seamless user experience and avoid churn. Also in some locations, such as enterprises, there is additional revenue potential in deploying dedicated premium solutions. Here, there is an opportunity to deploy small cells and dedicated indoor solutions based on the 3GPP standard – including micro cells, pico cells and small RRUs, as well as Wi-Fi.

These small cell solutions not only deliver high per-user capacity and rate coverage, they can also potentially improve performance in the macro network through traffic offload. Traffic offload is very important in problematic rate coverage situations in which users consume a disproportionate amount of network capacity since only a few user data bits can be sent per transmission time interval (TTI). The degree of coordination that can be achieved between different cell types throughout the heterogeneous network will determine overall network performance and user experience. Small cell solutions need to address a range of deployment scenarios, each with unique challenges and opportunities in terms of propagation properties, site availability, backhaul presence, and so on. The following sections focus on typical deployment scenario scenarios, paying significant attention to in-building applications, since not only do these present the biggest challenges in terms of user density and coverage isolation from the macro network, but they also offer

additional revenue opportunities from the deployment of dedicated solutions for premium services.

When adding small cells to an existing macro network, the preferred way of using spectrum is to reuse the frequencies already employed in the macro layer. If the network is under capacity pressure, it is likely that the macro network is already using the full range of frequency bands and technologies, since fully utilizing existing spectrum assets is a very cost-efficient way of evolving the network (as explained in the ‘improved macro’ section). In this case, operators may consider an alternative strategy to re-plan the network and devote a separate spectrum band to small cells. However, sharing spectrum among all cell types offers the following advantages:

1. Spatial reuse among all cells, leading to higher spectral efficiency. For example, splitting the spectrum into two equal parts a priori reduces the spectrum efficiency by a factor of two. Some of that loss is regained by lower load per carrier, but the net spectrum efficiency is always higher with shared spectrum. To illustrate, the diagram shows an LTE simulation, where the gain is quantified to 50% in a city street scenario with macro and outdoor deployed small cells.
2. Simplified load sharing and mobility, avoiding the risk of dropped calls inherent in inter-frequency handovers. In a recent small cell deployment trial in a major commercial network, it was observed that the critical dropped call rate KPI deteriorated from 0.5 percent to 1.2 percent when – for the purposes of the trial – the small cells were changed to a different frequency from the macro cells.
3. The benefits of small cells can only be fully realized when they are well coordinated with the overlaid macro network, and specifically in the uplink, soft handover and CoMP functionality are essential to getting the most from small cell deployments. These functions only work if shared spectrum is used. For example, in an LTE simulation of a city street small cell deployment, capacity is shown to increase by 100–200 percent (see the ‘city street’ section).
4. By sharing spectrum instead of splitting assets, for example into two, the full bandwidth is available in all cells, which implies double the peak rates. This effect will be increasingly pronounced as carrier aggregation functionality is rolled out.

Energy Consumption of Mobile Networks

5.1 Energy Consumption Metrics

Often, it is a requisite to quantify the energy consumption of mobile networks, so metrics that link the consumed energy to the coverage area and volume of transferred data become necessary. Designing an energy efficient network is supposed to be an optimization problem whose intent is minimizing the energy consumed by the network while still maintaining a prescribed quality of service (QoS). Therefore, it is important to consider the relation between energy consumption metrics and other performance quantities measuring the QoS. A typical characteristic is that the energy consumption tends to increase with the network load but the QoS experienced by the users is vitiated due to increased interference. The EARTH model [4] defines two metrics, or energy consumption indices (ECIs) to measure and compare the energy efficiency. These two are power per area unit and energy per bit and are described in the following sections.

1. The **power amplifier** in a BS normally suffers from poor power efficiency. This is because the PA is compelled to function in a non-saturated regime to avoid non-linear distortions causing adjacent channel interference. In macro BSs, where the PA consumes a large portion of the power, digital techniques such as pre-distortion is used to improve the power efficiency. These methods are however not used in smaller BS types where the PA accounts for a smaller part of the power consumption.
2. The **radio frequency** module serves as an analog-to-digital converter (ADC) for DL and uplink (UL) small-signals. Relevant factors for the RF power consumption is the required bandwidth, the allowable signal-to-noise and distortion ratio (SINAD), the resolution of the ADC and the number of antenna elements.
3. The **baseband module** is a digital signal processor that performs the digital up- and down-conversion, OFDM modulation and other digital operations. It also constitutes the link to the backhaul network. The power consumption of the baseband module is mainly determined by the signal bandwidth, number of TX/RX antennas and which algorithms that the processor applies.

5.1.1 Energy Consumption vs. Power Consumption

Power consumption is defined as the rate of energy consumed per unit of time. Alternately, power consumption integrated over time gives the energy consumption. Normally, there are more equipments on a site besides the RBS. The question is then what to include and omit in the calculation. There is no "one size fits all" recipe for this, so in order to get a complete picture it is recommended to clearly state what needs to be included.

RBS power consumption is calculated by using the following formula:

$$\begin{aligned}
 RBS\ power = & \left(\frac{1}{Power\ Conversion\ Efficiency} \right) \times \\
 & (C \times [(macroRadioUnits) + (DigitalUnits) + \\
 & (CabinetCooling)] + Remote\ Radio\ Units + \\
 & Antenna\ Integrated\ Radios + External\ Cable\ Losses)
 \end{aligned}
 \tag{5.1}$$

The variables in equation 5.1 are specified below.

1. **Power Conversion Efficiency** is a factor showing the losses when converting from the input voltage to the unit voltage of -48 V DC. Power conversion efficiency = 1 for -48 V DC input, and as a rough approximation is 0.9 for AC/DC or +24 V DC input. Power conversion efficiency varies with the type and LoadRate of the power conversion equipment.
2. **C** is a correction factor multiplying the data in the radio, digital and cabinet cooling power consumption to adjust for distribution losses and the actual temperature experienced by the HW inside the cabinet/enclosure.
3. **macro Radio Units** is the sum of the power consumption of the RUS or RUG belonging to one RBS. This term is dependent upon the output power. The dependence is approximated for Mutli-Carrier Power Amplifiers (MCPAs) by the following formula derived from factory measurements. The formula has a quadratic expression
 $Radiopowerconsumption = ax^2 + bx + c$, where x is the utilized output power measured in Watts at the antenna connector on the RBS.
4. **Digital Units** is the sum of the power consumption of the DUW and DUL and DUG and DUS inside the RBS. Since the power consumption of digital units varies with temperature, values are given both for typical cases (+25 °C outside the enclosure) and a high temperature +50 °C. Linear interpolation is used for temperatures in between these values. The +25 °C value is used for temperatures below +25 °C.
5. **Cabinet Cooling** is the sum of the cabinet cooling system power consumption. For indoor Macro RBSs and Main Units there are internal fans. For outdoor Macro RBSs and Main Units there are internal and external fans, separated from one another. Remote Radio Units is the sum of the power consumption of the RRUS belonging to one RBS.

6. **Antenna Integrated Radios** is the sum of the power consumption of the AIR belonging to one RBS. Similar to RUS and RUG, the power consumption of RRUS and AIR are also approximated by quadratic formulas
7. **External Cable Losses** refer to losses in the power cables leading to the RRU and/or AIR and/or cabinet/enclosure and may be included as requested.

Table 5.1: Values of C

	Macro	Main Units
C	1,05	1,02

5.2 Energy saving features

5.2.1 Cell Sleep

Capacity cells are turned on/off dynamically and automatically based on prevalent traffic load. This treasured attribute can reduce power consumption and also inter-cell interference. Therefore, Cell Sleep Mode feature can reduce OPEX (Operating Expenditure).

The main benefit of this feature is that energy savings are achieved in an automated fashion. In densely populated networks, overlaid cells are deployed in abundance and are turned on incessantly without this feature. With the Cell Sleep Mode feature, the overlaid capacity cells can detect low traffic conditions on their own and switch themselves off to save energy, with confirmed assistance from enshrouded coverage cells. The overlaid coverage cell monitors traffic conditions to turn on the sleeping capacity cells. This is a Self-Organizing Network (SON) capability that adapts to the network traffic conditions. Once overlaid capacity cells are turned off to preserve energy, the Cell specific Reference Signal (CRS) interference in the network is waned. This in turn consolidates the throughput of UE further.

Cell Sleep Mode Overview

In dense-urban areas, which is a cornucopia of overlaid cells(coverage as well as capacity), enabling Cell Sleep Mode feature on selected overlaid capacity cells by turning it off under low traffic conditions is very rewarding. When a capacity cell is turned off, traffic load existing in this cell is off-loaded to the coverage cells. These coverage cells can be configured manually or automatically. Cell Sleep Mode feature provides a capability called Coverage Cell Discovery, which can automatically detect neighboring cells that are good enough to serve as coverage cells. Enabling of Cell Sleep Mode feature is not required on coverage cells.

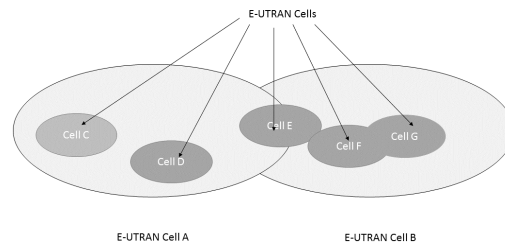

Figure 5.1: Energy Saving for E-UTRAN

Figure 5.1 illustrates a scenario in which E-UTRAN Cell C, D, E, F and G are covered by the E-UTRAN Cell A and B. Here, Cell A and B have been deployed to provide basic coverage, while the other E-UTRAN cells boost the capacity. When some cells providing additional capacity are no longer needed, they can be switched off for energy saving. In this case, both the continuity of LTE coverage and service QoS is guaranteed by coverage cells.

Feature Operation Sequence Diagram

In a network where cells are deployed, some are basic coverage cells, and others are capacity cells. Cell Sleep Mode feature proposes a strategy for the capacity cells to enter into energy saving mode automatically when they are neglected during low or no traffic conditions and to resume services automatically when traffic demand rises by coverage cell. In Figure 5.2, the simplified end-to-end normal work-flow for the feature is illustrated.

Coverage Cell Configuration

Automatic coverage cell configuration is performed by triggering coverage cell discovery. Coverage cell discovery is a continuous process that tries to automatically detect which neighboring cell can be coverage cell by using hit-rate estimation and how to configure the coverage cells. Coverage cell discovery identifies only inter-frequency neighbor relation as coverage cell. Hit-rate can be defined as the likelihood of a UE in the source cell to be qualified for offload to a certain target cell. It is assumed to replicate the target cell coverage with respect to the UE density and distribution in the source cell. Periodic measurement has to be done to estimate the **hit-rate** value for each target cell.

The hit-rate value of each target cell is used to decide coverage cells of the source cell by the following steps:

1. For each E-Utran inter-frequency relation, suitable coverage cell candidates are found out that have a hit-rate value greater than or equal to some internal threshold. For the same frequency, target cells can be aggregated to satisfy the threshold condition.

2. Then a frequency is selected, which meets the following conditions:
 - (a) The least number of aggregated cells.
 - (b) The highest hit-rate value. This condition has been added in case that multiple frequencies satisfying the first condition exist.
3. Coverage cell candidates of the selected frequency are finally configured as coverage cells of the source cell.

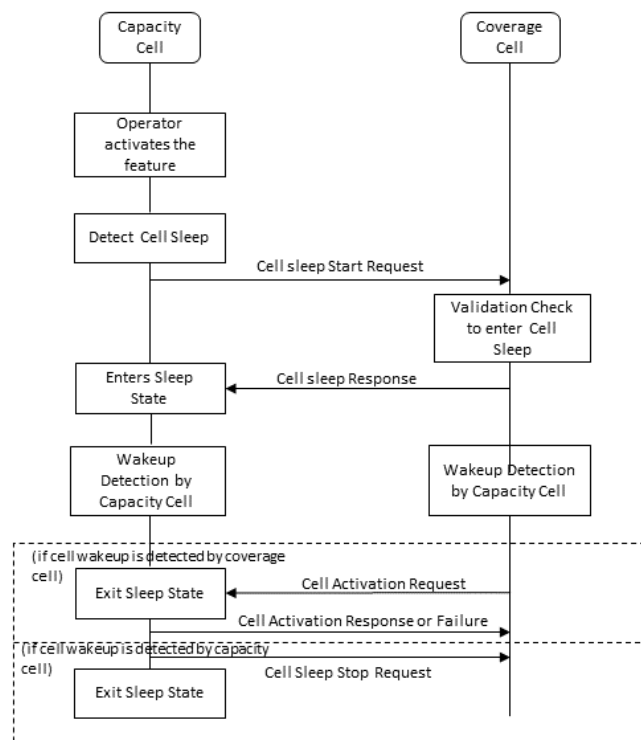

Figure 5.2: Cell Sleep Mode Operation Sequence

Validation Check to Enter Cell Sleep in Coverage Cell

After receiving a cell sleep start request from a capacity cell, the coverage cell performs the following validation to assess whether the capacity cell can enter sleep state:

1. Coverage cell and the capacity cell relation has to be properly defined.

2. Cell should not be overloaded in traffic and MP(multiprocessor) load perspective.
3. Cell should not be in either Cell Sleep state or MIMO sleep state.
4. Cell is not DL-only.
5. The cell should have the capacity to accept traffic offload from the requesting capacity cell.

Limitation

This feature is only supported on eNodeB. If a capacity cell and its coverage cells are not on the same eNodeB, X2 connection is mandatory [36]. The radio of a coverage cell can consume more power than the radio of a capacity cell when they are under the same traffic load condition. It is therefore instructed to use low sleep and wake-up thresholds to prevent excessive traffic load or power consumption on the coverage cells. It is highly advised to set low sleep and wake-up thresholds when the coverage cell uses a macro radio while the capacity cell uses a micro radio, or when the coverage cell discovery is enabled.

5.2.2 MicroSleep

The purpose of Micro Sleep Tx feature is to decrease energy consumption in the radio unit in the RBS. Energy is saved when the Power Amplifier (PA) is put in sleep mode when no user data needs to be transmitted. The benefit of the Micro Sleep Tx feature is that it enables energy saving in the radio unit in the RBS. Energy consumption is reduced when PA switches off on a symbol-time basis when there is no data to transmit on downlink (DL). This is a licensed feature. This means that for the feature to be operational, a valid license key must be installed and the feature must be explicitly activated.

Operational Description

Micro Sleep Tx feature is activated at node level. The de facto power saving is carried out in the radio unit by turning off the PA when there is no data to transmit.

PA is turned off for each symbol if there is no data to transmit DL. For each symbol, the Digital Unit (DU) or Baseband unit indicates to the radio unit if the PA can be turned off. To turn off PAs, there must be a guarantee that no data will be transmitted by any carrier using the same RF port in the case of Single Mode Multiple Carriers configuration. If there is data to transmit by at least one carrier that RF port’s PAs are in operation. If an Multimedia Broadcast Multicast Service (MBMS) sub-frame is transmitted, the PA always remains on. A new counter MicroTxSleepTime is introduced. It adds up durations of symbols for which DU or Baseband unit indicates that a PA can be turned off per Sector Carrier. This counter indicates the total amount of time that power savings can be achieved with the feature activated and radios capable of Micro Sleep Tx. This feature is limited,

as the counter does not measure how much power has actually been saved. If the configuration is not supported, the counter is stepped but energy consumption is not reduced. If the radio handles multiple sectors, the counter shows the potential power savings for the sector carrier however the radio only saves power when there is no data to transmit from all sectors.

Related Features

Table 5.2: Micro Sleep Tx features

Features	Description
MIMO Sleep Mode	This feature provides functionality to save energy by automatically switching the RBS from MIMO to SIMO based on the traffic load threshold set by the operator.

5.2.3 MIMO Sleep

This feature affects the following RAN features:

1. 4x2 Quad Antenna Downlink Performance Package
2. TDD only:4x4 Quad Antenna Downlink Performance Package
3. Dual-Antenna Downlink Performance Package
4. TDD only: Dual Layer Beamforming Performance Package
5. TDD only: Single Layer Beamforming Performance Package
6. FDD only: Transmit Data Cloning

The MIMO Sleep Mode feature reduces power consumption in the radio unit in the RBS. This is achieved by automatically changing a Multiple Input Multiple Output (MIMO) configuration to a Single Input Multiple Output (SIMO) configuration when low traffic conditions are detected on the cell. When running in SIMO configuration, the power consumption is reduced either by lower RF radiation at the radio unit, or by shutting down the radio unit Power Amplifier of the deactivated TX antennas. The decision point and the capability depend on the radio unit capacity.

Network Requirements

1. This feature has two capabilities, and the need for the feature license depends on which capability is used:
 - (a) Detection - The detection capability does not require a feature license, and allows evaluation of energy saving opportunities

- (b) **Switching** - The switching capability automatically changes cell configuration from MIMO to SIMO, or from SIMO to MIMO. For switching capability to be operational, a valid license key must be installed and the feature must be explicitly activated by setting a MOM attribute. See Feature Activation and Deactivation for more details.

Operation Description

The feature gives the eNodeB the capability to change the cell configuration from MIMO to SIMO when low traffic is detected on the cell. It provides the following:

1. On/off control
2. A daily time window to perform MIMO sleep detection
3. Detection threshold parameters for each cell

The MIMO Sleep Mode feature can be enabled on one or multiple cells on the node. The detection threshold parameters are used to control how the node performs traffic detection to go into MIMO sleep mode, and to resume from it.

The feature can be turned on in DETECTION mode without a license to evaluate and configure the MIMO Sleep Mode feature with optimal threshold settings. In this way, opportunities for time intervals where the cell can go to MIMO sleep mode can be found. When optimal feature configuration is evaluated, the feature can be turned on in switching mode. One feature license is required for each node to enable MIMO sleep switching capability on all the cells. In multi-DU configurations (where primary and extension DUs are connected to one radio unit) the order of locking and unlocking cells in each unit is very important. This feature performs switching automatically, according to cell traffic condition and does not guarantee the order of switching among cells. Therefore MIMO Sleep Mode is not recommended for this DU configuration.

The MIMO Sleep Mode feature supports the following modes of operation in a cell. They are configured by attribute sleepMode in the MimoSleepFunction MO:

1. **OFF** mode This is the default mode. Both MIMO sleep detection and switching capabilities are turned off for the cell.
2. **DETECTION** mode This is a detection-only mode that identifies opportunities to switch from MIMO to SIMO, and SIMO to MIMO. It also generates PM events and counters to report them.
3. **SWITCH** mode This mode enables both the detection and switching capabilities of the feature. The cell is locked immediately to perform the required reconfiguration.
4. **SOFT SWITCH** mode This mode enables both the detection and switching capabilities of the feature. Soft switch involves a cell shutdown operation before the cell is locked for reconfiguration. The shutdown process blocks incoming traffic, and pushes existing traffic out of the cell gracefully. SOFT

SWITCH mode is recommended to minimize impact on existing connections. However, compared to SWITCH mode it has a higher impact on cell accessibility due to additional time needed for cell shutdown.

Feature Configuration Parameters

Table 5.3 describes the parameters introduced by the feature.

Table 5.3: Mimo Sleep Parameters

Parameters	Description
sleepMode	MIMO sleep mode status for the cell
sleepState	Indicates if MIMO sleep mode takes effect as the cell has been reconfigured to a SIMO configuration.
sleepStartTime	Local daily start time to perform MIMO sleep detection or switching.
sleepEndTime	Local daily end time to stop MIMO sleep detection or switching.
sleepPowerControl	Power allocation method on the transmit branches during MIMO sleep Must be set to RETAIN_SAME_POWER if this cell share the same radio resource with other cells in this RBS, or with other cells/TRXs in other RBS.
switchDownMonitorDurTimer	MIMO sleep cell detection duration period before it is switched to SIMO configuration
switchDownPrbThreshold	Maximum percentage of Downlink Physical Resource Block (DL PRB) use allowed during the MIMO sleep mode detection period before it is switched to SIMO configuration.

For low traffic hours, MIMO Sleep Mode feature can temporarily decrease cell capacity due to cell reconfiguration from MIMO to SIMO. Incoming S1/X2 handover requests are rejected during cell reconfiguration from MIMO to SIMO, or from SIMO to MIMO.

Related Features

Table 5.4 lists features related to the MIMO Sleep Mode feature.

Table 5.4: Mimo Sleep Related Features

Feature	Description
Micro Sleep Tx	TDD only: This feature provides a function that decreases energy consumption in the radio unit in the RBS. Energy savings are achieved by putting the Power Amplifier in sleep mode when no user data needs to be transmitted. The MIMO Sleep Mode and Micro Sleep TX features can coexist on the same node and both can achieve power savings at different levels.
Cell Sleep Mode	This feature provides a function that decreases energy consumption by automatically turning off under-utilized overlaid capacity cells during low or no traffic conditions, and automatically turn them on when traffic resumes. The MIMO Sleep Mode and Cell Sleep Mode features can coexist on the same node. However, Cell Sleep Mode takes precedence over MIMO Sleep Mode if the required conditions are fulfilled.

5.2.4 Psi Coverage

A relatively new feature Psi-Coverage provides the LTE network operator an excellent solution for low-traffic sites. Compared to the alternative with a traditional three-sector solution, Psi-Coverage efficiently saves OPEX and CAPEX costs without affecting coverage and peak downlink bit rates by using one radio. At the same time, UL coverage is boosted in an efficient way [39].

Psi-Coverage solution uses a single radio unit to provide the same coverage as an ordinary 3-sector base station equipped with three radio units. Using less hardware reduces energy consumption, while maintaining the same performance. Psi-Coverage has also evolved to support multi-standard – both LTE and WCDMA. Psi Coverage is a unique innovation providing a solution for cost-efficient broadband coverage in areas with light to medium traffic volumes. Psi Coverage includes only one RRU (Remote Radio Unit) for an entire three-sector site, which is at least two fewer RRU’s compared to alternative solutions. This feature supports Carrier Aggregation (CA) as well, to improve DL peak bit rate. The Psi-Coverage feature also provides UE positioning, non-standard carrier bandwidth with special IBW and Antenna System Monitoring, the latter which is reused to detect disconnect cables or cables with poor connections.

Benefits of Psi-Coverage

1. Psi-Coverage enables accelerated deployment of Mobile Broadband Everywhere and reduces capital expenditure for LTE. This improves profitability of network coverage expansions into areas with fewer subscribers.
2. It uses one radio to establish an LTE coverage overlay onto a two, or three sectors GSM or WCDMA site grid, with an equivalent coverage.
3. It leads to lower operating expenditure, since only one radio is used. One radio consumes less energy than three radios.
4. It provides excellent end-user experience on sites with a low to medium number of subscribers.
5. It offers other substantial cost savings, which include installation, reduced tower load, and maintenance.
6. It makes capacity expansion to a standard three-sector site simple, as it reuses already deployed RBS hardware and antennas.
7. It provides UL coverage equal to that of a standard three-sector configuration.

Benefits of Psi-Coverage with Carrier Aggregation (CA):

1. It Increases downlink speed across the coverage area.
2. It makes more efficient use of scattered spectrum.
3. It provides higher cell capacity.
4. It provides four typical carrier aggregation enabled configurations with Psi-Coverage. This gives operators more choices to build high-speed networks compared to standard CA deployment.
5. It offers the operator to improve the deployed three-sector or Psi-Coverage network in an efficient way.

Limitations of Psi-Coverage

The feature has the following limitations:

1. Psi-Coverage with PUCCH overdimensioning does not support Sounding Reference Signal (SRS).
2. Psi-Coverage does not support:
 - (a) Time Division Duplex (TDD)
 - (b) Multistandard Mixed Mode (MSMM)
 - (c) Carrier Aggregation (CA) with FDD and TDD
 - (d) Carrier Aggregation (CA) with more than two carriers
 - (e) Psi solution enhancements with Y-coverage.

3. Psi-Coverage only supports 2Tx X 2Rx.

If UL and DL bandwidth are symmetrical, Psi-Coverage provides comparable capacity to common three-sector antenna cell configurations. If UL and DL bandwidth is asymmetrical, Psi-Coverage provides comparable downlink capacity and degraded uplink capacity to the common three-sector antenna cell configuration because of the frequency shifting on UL.

5.2.5 Lean Carrier(LC)

The Lean Carrier feature is strongly recommended to be used together with 256-QAM, since it improves 256-QAM performance in a macro network.

Feature Operation

Cell-specific Reference Signals (CRSs) are transmitted across the entire bandwidth of a cell, even when there is no traffic in the cell. The CRSs contribute to interference towards neighboring cells operating on the same frequency, which impedes DL performance. The Lean Carrier increases resource utilization and reduces interference by minimizing overheads induced by control channel and reference signal, eventually increasing spectral efficiency. It can increase spectrum flexibility and reduce energy consumption. Using ELC, the CRSs are transmitted only when UEs expect them to be present, otherwise they are muted.

Because, cell-specific reference signals which were habitually used by terminals to synchronize with the base station was removed on the Lean Carrier, a new reference signal has been added, which is referred to as an extended synchronization signal (eSS) [36]. The eSS is based on the CRSs, but it surfaces only once every five subframes. In order to maintain a working idle-mode cell mobility behavior, it is important that Reference Signal Receive Power (RSRP) and Reference Signal Receive Quality (RSRQ) measurements performed by UEs are not affected by the LC feature. This is achieved by transmitting CRSs at paging occasions and subframes where system information is transmitted.

Performance

The targets of the Lean Carrier, are as follows:

1. Enhanced spectral efficiency
2. Refined network energy efficiency
3. Full-fledged support to heterogeneous deployments
4. Improved spectrum flexibility support

The spectral efficiency is bettered mainly in sub-urban and rural areas where the traffic is relatively low because the once mandatory signals now have been removed on the Lean Carrier. The downlink transmissions on the Lean Carrier are based on the application of UE-specific reference signals that are only present within assigned downlink data transmissions. The UE-specific reference signal

overhead is proportional to the amount of data being transmitted but in case of the legacy carrier, the overhead is a constant. Energy efficiency can be increased at the network side by utilizing micro sleep operations. When the Base stations do not transmit, the power consumption within the radio and digital units is significantly reduced. In heterogeneous deployments, there is an urge to expand the cell area covered by low-power mode to serve a greater percentage of the total traffic. The Lean Carrier relies entirely on enhanced control channels, which permits the macro node to shield the control data in the low-power node by evading high interference on the Physical Resource Blocks(PRB) pairs used for control. Energy savings is actuated from two factors:

1. Foremost, and primarily the most important, due to fewer mandatory transmissions on the Lean Carrier, base stations can go into micro sleep more frequently.
2. Second, since the throughput is higher on the Lean Carrier, the buffers of the terminals are exhausted sooner, allowing base stations to be quiet for longer time periods.

LC is only expected to give significant gains on cell bandwidths 10,15 and 20 MHz, and is NOT recommended to be activated for bandwidths 1,4 MHz and 3 MHz. LC is active during low load only, with no impact on KPIs at high load – even if the LC feature is enabled. Once the load decreases in the cell, the LC operation is restored automatically.

Traffic Model

In order to calculate the energy efficiency, not only do we have to use the power saving features but also adopt a power model and a traffic model. The surroundings cannot be neglected and to make the optimum use of the power saving features, a comprehensive understanding of the traffic is crucial. In this chapter, the traffic model is explained with the the help of tables and two terms have been used extensively to define traffic. One is the Earth scenario and the other is the user activity.

Table 6.1 draws a relation between the Earth scenarios and the inter-site distance(ISD).

Table 6.1: Population density and related inter site distance (ISD) scenarios

EARTH scenarios	Population density	ISD	Operators per country
Dense urban	3000 citizen/km ²	500 m	3
Urban	1000 citizen/km ²	500 m	3
Sub-urban	500 citizen/km ²	1750 m	3
Rural	100 citizen/km ²	1750 m	3
Wilderness	25 citizen/km ²	3000 m	3
Custom scenarios			
Dense city center	10000 citizen/km ²	250 m	3
Super-dense city center	20000 citizen/km ²	200 m	3

The Inter-site distance(ISD) is an important entity as it defines the cell density of a network and is consequential in determining the cell radius. ISD can be used to determine the dominance area of a cell which could be considered the region where the signal intensity is the highest compared to other cells. For simplicity, here $ISD = 3 * \text{Cell radius}$. Well, it is an undeniable fact that the data traffic is never uniform and there are random variations throughout the day. But, to make computations more productive and consequential, a new term called "User activity" has been coined which is qualitative in nature rather than a quantitative value.

Busy hour(in %) gives a rough estimate of the daily data traffic where peak traffic is witnessed. This could range from an hour to few hours depending on the scenario. For this project, European style is adopted where ratio of busy hour traffic in a day has been assessed to be 7%.

Table 6.2 below gives an interpretation of the ratio of active users in busy hour for different Earth scenarios.

Table 6.2: Busy hour traffic scenarios

EARTH scenarios	User activity	Ratio of busy hour traffic in a day	Ratio of active users in busy hour
Extreme flat	Low	4%	10%
	Average	4%	16%
	High	4%	25%
	Extreme	4%	33%
Very flat	Low	5%	10%
	Average	5%	16%
	High	5%	25%
	Extreme	5%	33%
American style	Low	6%	10%
	Average	6%	16%
	High	6%	25%
	Extreme	6%	33%
European style	Low	7%	10%
	Average	7%	16%
	High	7%	25%
	Extreme	7%	33%

Classifying the devices that adds up to the data traffic into three broad divisions, namely Smart phones, Mobile PC and Tablets, it becomes convenient to figure the monthly data traffic.

Table 6.3 doles out Traffic essentials extracted from Ericsson Mobility report (2014).

Table 6.3: Traffic essentials from Ericsson Mobility Report (2014 Nov)

Monthly data traffic [MB/month]	2014	2015	2016	2017	2018	2019	2020
Smartphone	900	1129	1415	1775	2226	2791	3500
Mobile PC	4300	5295	6521	8031	9890	12180	15000
Tablet	1900	2394	3016	3800	4788	6032	7600

The findings in the above table is a result of continuous extrapolations, particular interest being in the year 2017. The monthly data traffic for the devices mentioned in Table 6.3 is purely mathematical in nature and could bear a slight resemblance to real scenarios. In other words, each row corresponding to a specific device portrays the data used assuming it is the sole device and there is no data consumption from other devices. This brings us to table 6.4 which exhibits the ratio of devices. These values assists in evaluating the data rate (calculated in the next section) which is more proximal to actual scenario.

Table 6.4: Ratio of Devices

Smart Phone	60%
Mobile PC	30%
Tablet	10%

Radio Access Technology (RAT) is not just restricted to LTE and comprises of GSM and WCDMA. Because all of our calculations are based on LTE network model and parameters, it becomes imperative to concentrate only on LTE and discard others in the RAT deployment. Table 6.5 lays out the RAT deployment for 2017.

Table 6.5: RAT Deployment

GSM	1%
WCDMA	20%
LTE	70%

The monthly data rate has been computed but it becomes meaningless without the knowledge of the number of LTE subscribers.

Table 6.6 is about Traffic and Coverage which is an approximation after data gathered by Ericsson and the operators in Germany.

Table 6.6: Traffic and Coverage (2017)

Deployment	Population Density	Covered Area	Actual Area(km ²)	Population (in thousands)	No. of subscribers
Super dense urban	20000	0.05%	310.7	6214	2174900
Dense urban	3000	0.95%	5902.9	17709	6198150
Urban	1000	2%	12427.2	12427	4349450
Sub-Urban	500	4%	24854.4	12427	4349450
Rural	100	36%	223689.3	22369	7829150
Sparsely populated	25	57%	354174.8	8854	3098900
Total			621359	80000	28000000

The table 6.6 gives a fair idea how a country can be split into several territories with varied population density and RAT deployment. The number of subscribers is a useful data which will be used in subsequent calculations. Table 6.7 and 6.8 below demonstrates the user activity(H- high, M- medium, L -low).

Table 6.7: User activity based on total area (LTE- 2017)

		3%	40%	57%
	Tot Area	H	M	L
Super dense urban	310.7	9.321	124.28	177.099
Dense urban	5902.9	177.087	2361.16	3364.653
Urban	12427.2	372.816	4970.88	7083.504
Sub-Urban	24854.4	745.632	9941.76	14167.008
Rural	152230	6710.679	89475.72	56043.601

Table 6.8: User activity based on total subscribers (LTE- 2017)

		45%	43%	12%
	Tot Subs	H	M	L
Super dense urban	785391.6	353426.22	341566.8	90398.57
Dense urban	2237911	1007060	973267.6	257583.6
Urban	1569772	706397.58	682694	180680.8
Sub-Urban	1569772	706397.58	682694	180680.8
Rural	2826197	1271788.6	1229113	325295.3
Total		4045070	3909335	1034639

Finally, Table 6.9 to Table 6.11 gives a traffic model of only some important scenarios. There would be a lot of combinations if the user activities (High, medium and low) are combined with the Earth scenarios (Super Dense urban, dense urban, urban, sub-urban and rural). Though not all traffic models are shown here, the results chapter takes into account of the respective model while calculating the energy efficiency. The traffic model is based on Table 6.1, 6.2, 6.3, 6.4 and some mathematical computations described in the steps below.

Procedure:

1. Traffic per subscriber as function of devices.

(a) Calculation of Monthly Data consumed for all the devices.

$$Data_{Smartphone} = Ratio_{Smartphone} \times Monthly\ Data_{Smartphone} \quad (6.1)$$

$$Data_{PC} = Ratio_{PC} \times Monthly\ Data_{PC} \quad (6.2)$$

$$Data_{Tablet} = Ratio_{Tablet} \times Monthly\ Data_{Tablet} \quad (6.3)$$

$$Monthly = Data_{Smartphone} + Data_{PC} + Data_{Tablet} \quad (6.4)$$

(b) Calculation of daily traffic.

$$Daily = Monthly \times \left(\frac{12}{365}\right) \quad (6.5)$$

(c) Calculation of busy hour.

$$Busy\ hour = Daily \times Ratio\ of\ busy\ hour \quad (6.6)$$

(d) Calculation of Average Bit Rate of Active Users in Busy Hour.

$$Average\ bit\ rate\ of\ active\ users\ in\ busy\ hour = Busy\ hour \times (8/3600) \times 1000 \times Ratio\ of\ active\ users\ in\ busy\ hour \quad (6.7)$$

2. Country wide.

(a) Calculation of Active Users in Busy Hour.

$$\begin{aligned} \text{Active users in busy hour} &= \text{Population density} \times \\ &\text{Ratio of active users in busy hour} \end{aligned} \quad (6.8)$$

(b) Calculation of Area throughput.

$$\begin{aligned} \text{Area throughput} &= \text{Average bit rate of active users} \\ &\text{in busy hour} \times \text{Active users in busy hour} \end{aligned} \quad (6.9)$$

3. Operator Average.

(a) Calculation of active users in busy hour.

$$\begin{aligned} \text{Active users in busy hour} &= \text{Active users in busy hour} \\ &\text{(countrywide)}/\text{Operators per country} \end{aligned} \quad (6.10)$$

(b) Calculation of active users in busy hour (number of users per cell).

$$\begin{aligned} \text{Active users in busy hour} &= \left(\frac{9}{8} \times \sqrt{3} \times \left(\frac{2}{3} \times \text{ISD}/1000\right)^2 / 3 \times \right. \\ &\left. \text{Active users in busy hour (Operator avg)} \right) \end{aligned} \quad (6.11)$$

(c) Calculation of Area throughput.

$$\begin{aligned} \text{Area throughput} &= \text{Area throughput (countrywide)}/ \\ &\text{Operators per country} \end{aligned} \quad (6.12)$$

Table 6.9 represents the traffic model of dense urban region where high activity is encountered from the years 2014 to 2020 by extrapolating the data. The next two tables 6.10 and 6.11 depict the traffic model but for urban region medium activity and rural area with low activity.

Table 6.9: Traffic model of Dense-urban high activity scenario

Country wide	2014	2015	2016	2017	2018	2019	2020
Area throughput(in Mbps/km ²)	30.99	38.44	47.67	59.13	73.36	91.01	112.92
Active users in busy hour(in users/km ²)	750	750	750	750	750	750	750
Operator average	2014	2015	2016	2017	2018	2019	2020
Area throughput(in Mbps/km ²)	10.33	12.81	15.89	19.71	24.45	30.34	37.64
Active users in busy hour(in users/km ²)	250	250	250	250	250	250	250
Traffic per subscriber as function of devices							
Monthly(in MB/mo)	2020	2505	3107	3854	4781	5932	7360
Daily(in MB/mo)	66.4	82.4	102.2	126.7	157.2	195	242
Busy hour(in MB)	4.65	5.77	7.15	8.87	11	13.65	16.94
Average bitrate of active users in busy hr(in kbps)	41.3	51.2	63.6	78.8	97.8	121.3	150.6

Table 6.10: Traffic model of Urban medium activity scenario

Country wide	2014	2015	2016	2017	2018	2019	2020
Area through-put(in Mbps/km ²)	10.33	12.81	15.89	19.71	24.45	30.34	37.64
Active users in busy hour(in users/km ²)	160	160	160	160	160	160	160
Operator average	2014	2015	2016	2017	2018	2019	2020
Area through-put(in Mbps/km ²)	3.44	4.27	5.30	6.57	8.15	10.11	12.55
Active users in busy hour(in users/km ²)	53	53	53	53	53	53	53
Traffic per subscriber as function of devices							
Monthly(in MB/mo)	2020	2505	3107	3854	4781	5932	7360
Daily(in MB/mo)	66.4	82.4	102.2	126.7	157.2	195	242
Busy hour(in MB)	4.65	5.77	7.15	8.87	11	13.65	16.94
Average bitrate of active users in busy hr(in kbps)	64.6	80.1	99.3	123.2	152.8	189.6	235.3

Table 6.11: Traffic model of Rural low activity scenario

Country wide	2014	2015	2016	2017	2018	2019	2020
Area through-put(in Mbps/km ²)	1.03	1.28	1.59	1.97	2.45	3.03	3.76
Active users in busy hour(in users/km ²)	10	10	10	10	10	10	10
Operator average	2014	2015	2016	2017	2018	2019	2020
Area through-put(in Mbps/km ²)	0.34	0.43	0.53	0.66	0.82	1.01	01.25
Active users in busy hour(in users/km ²)	3	3	3	3	3	3	3
Traffic per subscriber as function of devices							
Monthly(in MB/mo)	2020	2505	3107	3854	4781	5932	7360
Daily(in MB/mo)	66.4	82.4	102.2	126.7	157.2	195	242
Busy hour(in MB)	4.65	5.77	7.15	8.87	11	13.65	16.94
Average bitrate of active users in busy hr(in kbps)	103.3	128.1	158.9	197.1	244.5	303.4	376.4

7.1 Base Station Power Models

The transmit power of the BSs, i.e. the power radiated from the transmit antennas, is an important parameter that influences the efficacy of wireless networks. However, designing any energy efficient network requires knowledge of the overall consumed power as well. Generally, the consumed power in a BS is higher than the radiated power as other incidental processes such as cooling and baseband signal processing consume an inconsequential amount of power. A power model is a mapping from the radiated power to the consumed power. As part of the EARTH project a state of the art (SoTA) BS power model was developed in order to assess the energy consumption at system level. The breakdown of the power consumption of the modules in a BS and their load dependency showed that a linear power model is relatively accurate.

Linear power models are consistently used in simulation studies of mobile network energy consumption. A BS comprises of several transmitter and receiver (TRX) modules. Each TRX module contain an antenna interface (AI), a power amplifier (PA), a radio frequency (RF) small signal module, a baseband (BB) engine, an active cooling system, a DC-DC power converter and a main power supply connected to the electrical power grid.

The antenna interface is the connection between the PA and the antenna. Here signals undergo power losses due to feeders, filters and other components and therefore it becomes relevant to consider them in a power model. In remote radio head (RRH) units the PA is moved to the antenna location to limit the effect of feeder losses.

7.2 Structure of the Energy Model

The power model is built by splitting the base station into a number of components and sub-components, as shown in Figure 7.1. This section tries to introduce those components, and differentiates between different base station types, and tries to present the main parameters applied to compute the power consumption in a specific scenario.

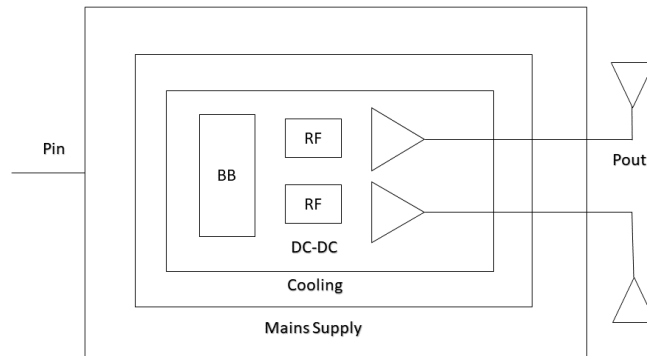

Figure 7.1: Base station components included in our power model

7.2.1 Base station types and general parameters

A base station in a wireless system that uses microwave radio communication is normally positioned in a location far above the grounded area providing coverage. They are mounted on high towers as it is more effective to stay in communication with user equipment, which are often near the ground and also to overcome obstacles, such as trees, hills, or tall buildings, that stand between the base station and UE. The real antenna elements of a base station are typically not more than few inches, but may be organized into clusters or “arrays” which may grow to 1 meter. Different types of base stations are set up according to the coverage needed. Four types of base stations have been included in the adopted model based on the coverage radius, namely: macro, micro, pico, and femto. The difference between these base stations lie in the sub components that make them up and the power figures associated with those sub-components (output power, maximum load, signal accuracy etc). This implies that despite having similar sub components the basic architectures tends to be slightly varied, for example small base stations (pico and femto) make use of more power-efficient dedicated components while large base stations (macro and micro) might require more reconfigurability; field programmable gate arrays (FPGAs) are more operative and almost passive use of dedicated hardware. This translates into different intrinsic power efficiencies each serving its own purpose.

Macro base stations are also characterized in the model by having a variable number of sectors, generally 3 while other base station types only have one mainly because of the small coverage size. The four base station types also differ in maximum output power with macros having the highest and femtos having the least. The other factor that affects the power consumption is the silicon technology. There are two ways of specifying this feature, one is by specifying the CMOS fea-

ture size in nanometer(nm) and the other way is by the year of deployment. The default value for silicon technology is 65 nm or 2010 deployment. [42]

Finally, there are other additional general parameters that define the losses of various sub-components related to the power systems of the base station. This includes losses from cooling, AC/DC conversion, DC/DC conversion and antenna feeder. The first three terms are described in subsection titled "Overhead". Antenna feeder losses are only present between the PA and the antenna in macro base stations. These losses have been combined together along with the PA model. Smaller base station types have negligible feeder losses due to their more compact design so they have been omitted.

7.2.2 Base station sub-components and scaling parameters

The sub-component can be better understood by categorizing them under two brackets. First on the basis of real hardware and architecture, e.g., analog RF part versus digital baseband part, and the second one being functional role, e.g., time-domain processing versus frequency-domain processing. The architecture can be further fractionated to include digital baseband, RF (analog), power amplifier, and overhead (power systems and cooling).

$$P_{Total} = P_{BB} + P_{RF} + P_{PA} + P_{Overhead} \quad (7.1)$$

where,

P_{Total} = Total power consumed at the base station

P_{BB} = Power in the digital baseband

P_{RF} = Power in RF(analog)

P_{PA} = Power in the power amplifier

$P_{Overhead}$ = Power needed for cooling etc.

Breaking down into smaller components makes it simpler to establish clear links to the power consumption of specific components and scaling is done because in the equation there are both time domain and frequency domain computations with the changing system load and modulation schemes. Table 7.1 includes the set of parameters that affect scaling of the analog and digital components. [42]

Table 7.1: Parameters affecting scaling of baseband and RF power consumption

Notation	Description	Range	Default
BW	Bandwidth[MHz]	1.4 -20	10
Ant	Number of antennas	1,2,4	2
M	Modulation	1,2,4,6	6
CR	Coding rate	1/3 -1	5/6
Δt	Time-domain duty-cycling	0-1	1
Δf	Frequency-domain duty-cycling	0-1	1

The scaling approach well defines both baseband and RF power consumption. Representing BB as the set of baseband subcomponents, RF the set of analog subcomponents, and $Z = \{BW, Ant, M, CR, \Delta t, \Delta f\}$ the list of parameters as described in Table 6.1, equation 7.1 could be further expanded to get the following expression [43].

$$\begin{aligned}
 P_{Total} = & \sum_{i \in I_{BB}} P_{i,ref} \prod_{x \in Z} \left(\frac{x_{act}}{x_{ref}}\right)^{s_{i,x}} \\
 & + \sum_{i \in I_{RF}} P_{i,ref} \prod_{x \in Z} \left(\frac{x_{act}}{x_{ref}}\right)^{s_{i,x}} \\
 & + P_{PA} + P_{overhead}
 \end{aligned} \tag{7.2}$$

Both in the uplink and downlink transmission the number of antennas is assumed to be same, and also the same number of spatial streams. Time-domain duty-cycling in table 7.1 indicates the fraction of time during which the base station is entirely operating, which means it completely sleeps during the rest of the time. This is an interesting conjecture in order to reduce the average power consumption [44]. However, this largely depends on the hardware design and on the swiftness at which transitions between active and sleeping states are performed, so the full sleeping assumption though sounds promising but is too good to be true. This was taken into account to determine the power consumption, as further discussed in "Results" chapter. Frequency-domain duty-cycling depicts the fractional load of the system in frequency resources, i.e., physical resource blocks (PRBs). The scaling factors are exponents associating each power contributor in the model to each parameter of the model.

7.2.3 Model Components

This section details the power models of the different components of a base station, i.e., the digital baseband, the analog RF, the power amplifier and the power system (power conversion and cooling).

Digital Baseband processing

The digital processing is modeled based on estimated complexity in Giga operations per second (GOPS), multiplied by a dependent factor that relies on the CMOS technology and can be better expressed as the number of operations that can be performed per second and per Watt. This factor is hypothecated to 40 GOPS/W for macro base stations and default technology, which is 65 nm General Purpose CMOS. This value is almost three times larger for pico and femto cells as they handle dedicated hardware. The complexity of Digital Baseband can further be subdivided into a number of sub-components:

1. DPD: Digital Pre-Distortion
2. Filter: up/down-sampling and filtering
3. CRPI/SERDES: serial link to backbone network
4. OFDM: FFT and OFDM-specific processing
5. FD: Frequency-Domain processing (mapping/demapping, MIMO equalization); it is divided into two parts, scaling linearly and non-linearly with the number of antennas
6. FEC: Forward Error Correction
7. CPU: platform control processor

The frequency domain processing has both linear and non linear operations depending on the number of antennas. Almost all the components fall under linear part. The non-linear part of frequency-domain processing accounts for the MIMO operations (2 or more antennas) with quadratic or even cubic scaling. Combining both the linear and non linear operations and adding even the leakage power leads to the following total baseband power consumption.

$$P_{BB} = P_{Dynamic} + P_{Leak} + P_{PA} + P_{Overhead} \quad (7.3)$$

where

$$P_{Dynamic} = P_{DPD} + P_{Filter} + P_{OFDM} + P_{FD,lin} + P_{FD,nl} + P_{CRPI} + P_{FEC} + P_{CPU} \quad (7.4)$$

The reference leakage power is defined as function of the reference dynamic power, where η_{Leak} is 0.1 in 65 nm CMOS technology. A detailed explanation can be found in [42].

$$P_{Leak,Ref} = \eta_{Leak} P_{Dynamic,Ref} \quad (7.5)$$

RF Sub-components

The RF architecture could get quite complex as it contains numerous different elements of a low-IF/zero-IF architecture that includes clock/carrier generation and distribution, modulator, mixers, low-noise amplifier (LNA), variable-gain amplifier (VGA), analog/digital converters(DAC and ADC), filters, buffer and pre-driver,

and feedback chain. Though the power amplifier is a part of RF sub component it is treated and discussed separately in the next because it has a different modeling approach. The scaling of RF power with input parameters is done in the following manner. Every RF sub-component are assigned a scaling exponent 1 with respect to number of antennas and time-domain duty cycling. The scaling exponents have the value zero for carrier and clock generation sub-components. The RF sub-components related to frequency-domain duty-cycling have scaling exponent one.

Power amplifier

The power amplifier has an unusual behavior that cannot be captured by a single reference power number and scaling rules. Hence, the PA model is provided by looking into the base stations. There is almost negligible amount of dynamic power, so the power model of today’s typical macro base station can be reduced to just the static part. Base stations with dynamic power saving features have appeared only very recently [47] and are not yet wide spread in the networks.

The efficiency of a power amplifier from the input side is mainly determined by the applied modulation schemes and its crest factor. For modeling the power consumption, the following formula is used. [48]

$$P_{BS,Macro} = N_{Sector} \cdot N_{PApSec} \left(\frac{P_{TX}}{\mu_{PA}} + P_{SP} \right) (1 + C_C) (1 + C_{PSBB}) \quad (7.6)$$

The parameters mentioned in Equation 7.6 have been expressed in Table 7.2.

Table 7.2: Linear power model parameters

Parameter	Description
N_{Sector}	Number of sectors
P_{TX}	TX power
P_{SP}	Signal Processing overhead
C_{PSBB}	Battery backup and power supply loss
N_{PApSec}	PAs per sector
μ_{PA}	PA efficiency
C_C	Cooling loss

A micro base station is considered to consist of one sector containing one PA. The load can varies between no load to full load, interpreted by 0 and 1, respectively. The power amplifier in micro BS has a reduced efficiency compared to the PA of a macro base station. No pre-distortion is applied. A PA efficiency of 20% is assumed. Nevertheless, in comparison to the macro base station the absolute power consumption is greatly reduced due to the smaller coverage area

and thus much smaller transmit power requirement and hence only one PA. The power consumption in micro BS has a more dynamic nature, because the variation in the number of users is strong statistically. This is chiefly due to the smaller cell radius and the users hover from one cell to another and this makes it fetching to adapt the PA during a certain time period with lower load.

$$P_{BS, Micro} = P_{static, Micro} + P_{dynamic, Micro} \quad (7.7)$$

The dynamic part of the power consumption in a micro base station comes from the digital baseband. The power consumption vary according to the load. There is no requirement of any battery backup for micro base stations. The power supply loss is approximately 10% and depends on the technology. There are several parameters that epitomizes the properties of a micro BS given in Table 7.3.

Table 7.3: Micro BS power model parameters

Parameter	Description
$P_{Static, Micro}$	Static power consumption
P_{TX}	Max TX power per PA
N_L	Number of active links
$C_{TX, NL}$	Dynamic TX power per link
$P_{Sp, NL}$	Dynamic signal processing per link
$P_{dynamic, Micro}$	Dynamic power consumption
μ_{PA}	PA efficiency
$C_{TX, static}$	Static TX power
$P_{SP, static}$	Static signal processing
C_{PS}	Power supply loss

The formula for static and dynamic power consumption in a micro BS is given by :

$$P_{static, Micro} = \left(\frac{P_{TX}}{\mu_{PA}} C_{TX, static} + P_{SP, static} \right) (1 + C_{PS}) \quad (7.8)$$

$$P_{dynamic, Micro} = \left(\frac{P_{TX}}{\mu_{PA}} (1 - C_{TX, static}) C_{TX, NL} + P_{SP, NL} \right) (N_L) (1 + C_{PS}) \quad (7.9)$$

Overhead

There are remaining sub-components that are related to the system powering that includes AC/DC and DC/DC conversion as well as cooling. These components consume minimal power individually but still cannot be ignored so they are placed in the overhead category. In order to keep the model simple, the power is computed

as a fixed overhead that linearly depends on the total power of the rest of the base station. The overhead power can be computed as below.

$$P_{overhead} = (P_{BB} + P_{RF} + P_{PA}) \times ((1 + \eta_{cool} (1 + \eta_{dcdc}) (1 + \eta_{acdc}) - 1) \quad (7.10)$$

Default values for the linear loss model are 10% for cooling, 5% for DC/DC conversion, and 10% for AC/DC conversion. The default values apply to every kind of base station. There is no cooling for smaller base stations so the 10% value is applicable only to macro base station.

7.3 Radio Shelf

The RBS 6000 family portrayed in [46] which has been used as part of this project has the following radio components for LTE.

1. RU- Radio Unit
 - (a) Transceiver (TRX)
 - (b) Transmitter (TX) amplification
 - (c) TX/RX duplexing
 - (d) TX/RX filtering
 - (e) Antenna support
2. DU- Digital Unit
 - (a) Control processing
 - (b) Clock distribution
 - (c) Synchronization from transport network
 - (d) Baseband processing
 - (e) RU interconnects
 - (f) Maintenance interface

The radio and the the digital units are the major power consuming components. To make calculations smoother, power consumption of all these components have been computed based on the power model of each component individually and the summation of all these would provide a good estimation of the total power consumption. Two Digital units and two Radio units following the power model have been selected in this study with slight upgradations developed in [45].

Power Consumption of Digital Units in [W]

$$DUA = 150 . \quad DUB = 140 .$$

Power Consumption of Radio Units in [W]

$$RUA = 380 . \quad RUB = 250 .$$

Chapter 8
Results

8.1 Prelude

This chapter is devoted to present the results generated for this master’s thesis. LTE parameters have been adopted for all the simulations performed. The simulation parameters and the models have been selected in accordance with the 3GPP model [40]. The reuse of heterogeneous network has been made to illustrate the potential energy savings by embracing effective energy saving features.

This is a comparative study where the annual power consumption is first evaluated without utilizing the energy savings features and then ciphering the power savings with the aid of the improvements as discussed in Chapter 5. The data input to the model has been based on the data survey of a "typical" German city. The city is then balkanized into so called "Earth scenarios". More specific details have been provided in the table 6.1 below which explains the cause for this demarcation.

8.2 Power Calculation Prior to Energy Saving Features

The previous section was a sort of exordium where an effort was meant to give a background about LTE traffic coverages in different EARTH scenarios and its usefulness.

In this section, power and energy calculation will be accomplished that rests on preliminary research and arithmetic done in the last section. The power consumed in a year does not speak much about the efficiency of the system as it is subject to conditions which could be population density, geographical regions and types of deployment. So, to compare the results, there is a need to establish a singular parameter that covers all factors and meanwhile, easily computable. In this thesis, **Energy consumed per bit** has been used as the decisive parameter. The aim of this thesis is to minimize energy consumed per bit without affecting the throughput considerably. All the computations here will be sans power saving features.

Like mentioned earlier, most of the power consumption transpires in the base station so our focus is invested predominantly in this area. The Radio base station (RBS) can be broken down into several components, but for simplicity only Digital units (DU), Remote radio units (RRU) and Transport Connectivity Units (TCU) are considered.

Table 8.1 and 8.2 provides the number of units of each kind estimated to be installed by 2017. Again, the numbers are conditioned by the user activity and the kind of scenarios.

Table 8.1: RBS Components Distribution (2017)

Scenarios		Super Dense			Dense Urban			Urban		
Activity		High	Med	Low	High	Med	Low	High	Med	Low
LTE	DUA	92	706	0	883	7027	0	0	0	0
	DUB	0	0	601	0	0	2622	469	1477	380
	RUA	552	4236	1803	5298	42162	7866	2814	8862	2280
	RUB	276	2118	0	2649	21081	0	0	0	0
Site Trans	TC	50	333	281	500	3602	1599	435	1891	582

Table 8.2: RBS Components Distribution (2017)

Scenarios		Sub urban			Rural		
Activity		High	Med	Low	High	Med	Low
LTE	DUA	0	0	0	0	0	0
	DUB	96	162	56	137	198	102
	RUA	576	972	168	822	1188	612
	RUB	0	0	0	0	0	0
Site Trans	TC	96	321	103	142	304	389

Two classes of Digital and Radio units have been implemented as part of this venture. DUA and DUB comes under DU and RUA and RUB are parts of RU. Every component is independent of each other and have distinctive features and hence non-identical power consumption. This is substantiated in table 8.3.

Total Power Calculation in [W]

The total power calculation is a simple process which involves determining the number of Digital and Radio units instated and the varied power consumption of the individual components. Equations 8.1 to 8.3 calculates the total power consumed and all the variables have been interpreted.

Table 8.3: Power Consumption of DUA, DUB and RUA,RUB (2017)

DU Power Consumption [W]		
LTE	DUA	150
	DUB	140
RU Power Consumption [W]		
LTE	RUA	380
	RUB	250

N_{DUA} = Number of units of DUA deployed.

N_{DUB} = Number of units of DUB deployed.

N_{RUA} = Number of units of RUA deployed.

N_{RUB} = Number of units of RUB deployed.

Pow_{DUA} = Power consumption of 1 DUA unit.

Pow_{DUB} = Power consumption of 1 DUB unit.

Pow_{RUA} = Power consumption of 1 RUA unit.

Pow_{RUB} = Power consumption of 1 RUB unit.

$Tot_pow_{no_sav}$ = Total power consumption without energy savings.

$$Pow_DU_{nosav} = N_{DUA} * Pow_{DUA} + N_{DUB} * Pow_{DUB} \quad (8.1)$$

$$Pow_RU_{nosav} = N_{RUA} * Pow_{RUA} + N_{RUB} * Pow_{RUB} \quad (8.2)$$

$$Tot_pow_{nosav} = Pow_DU_{nosav} + Pow_RU_{nosav} \quad (8.3)$$

Table 8.4 provides the total power consumption of both the digital units DUA and DUB separately for different combinations of scenarios and user activities. The calculation is palpable and is obtained by multiplying the number of units with the power used by one unit.

Table 8.4: Power Consumption of DU(2017)

Scenario	Activity	DUA (in units)	Power (per unit)	DUA Total power	DUB (in units)	Power (per unit)	DUB Total power
Super Dense	High	92	150	13800	0	140	0
	Medium	706	150	105900	0	140	0
	Low	0	150	0	601	140	84140
Dense Urban	High	883	150	132450	0	140	0
	Medium	7027	150	1054050	0	140	0
	Low	0	150	0	2622	140	367080
Urban	High	0	150	0	469	140	65660
	Medium	0	150	0	1477	140	206780
	Low	0	150	0	380	140	53200
Sub Urban	High	0	150	0	96	140	13440
	Medium	0	150	0	162	140	22680
	Low	0	150	0	56	140	7840
Rural	High	0	150	0	137	140	19180
	Medium	0	150	0	198	140	27720
	Low	0	150	0	102	140	14280

Table 8.5 is comparable to the previous table but instead it provides the total power consumption of both the radio units RUA and RUB separately for different combinations of scenarios and user activities. It follows the same mathematical principle of multiplying number of units with power exhausted by one unit.

Table 8.5: Power Consumption of RU(2017)

Scenario	Activity	RUA (in units)	Power (per unit)	RUA Total power	RUB (in units)	Power (per unit)	RUB Total power
Super Dense	High	552	380	209760	276	250	69000
	Medium	4236	380	1609680	2118	250	529500
	Low	1803	380	685140	0	250	0
Dense Urban	High	5298	380	2013240	2649	250	662250
	Medium	42162	380	16021560	21081	250	5270250
	Low	7866	380	2989080	0	250	0
Urban	High	2814	380	1069320	0	250	0
	Medium	8862	380	3367560	0	250	0
	Low	2280	380	866400	0	250	0
Sub Urban	High	576	380	218880	0	250	0
	Medium	972	380	369360	0	250	0
	Low	168	380	63840	0	250	0
Rural	High	822	380	312360	0	250	0
	Medium	1188	380	451440	0	250	0
	Low	612	380	232560	0	250	0

$$Pow_DU_{nosav} = 1306200 + 882000 = 2188200 \text{ W from equation 8.1}$$

$$Pow_RU_{nosav} = 30480180 + 6531000 = 37011180 \text{ W from equation 8.2}$$

The total power spent is the sum of the powers used by both the DUs and RUs.

$$Tot_pow_{nosav} = 2188200 + 37011180 = 39199380 \text{ W from equation 8.3}$$

Total Energy Calculation in [kWH]

$$Energy_annual_{nosav} = (Tot_pow_{nosav} * 24 * 365) / 1000 \quad (8.4)$$

$$Energy_annual_{nosav} = (39199380 * 24 * 365) / 1000 = 343386568.8 \text{ kWH}$$

$$LTE_subscribers = \left(\sum_{i=1}^5 D_i \right) \quad (8.5)$$

where D_i is the RAT deployment scenarios given in Table 6.5. Sparsely populated region is excluded assuming no LTE is currently present there.

$$LTE_subscribers = 24901100$$

$$Monthly_datarate = \left(\sum_{i=1}^3 (Mon_i * R_i) \right) \quad (8.6)$$

where Mon_i is the monthly consumption of device and R_i is the ratio of devices given in Table 6.3 and 6.4 respectively.

$$Monthly_datarate = (1774.41 * 0.6) + (8032 * 0.3) + (3800.16 * 0.1) = 3854.2511 \text{ MB/month}$$

$$Data_consump = LTE_subscribers * LTE_deploy_rate * Monthly_datarate \quad (8.7)$$

$LTE_deploy_rate = 0.7$ from Table 6.5

$$Data_consump = 24901100 * 0.7 * 3854.2511 = 67182564823 \text{ MB/month}$$

$$Data_annual = Data_consump * 8 * 10^6 * 12 \quad (8.8)$$

$$Data_annual = 67182564823 * 8 * 10^6 * 12 = 6.44953 * 10^{18}$$

$$Energy_annual_con_perbit = (Energy_annualnosav * 10^3) / Data_annual \quad (8.9)$$

$$Energy_annual_con_perbit = (343386568.8 * 10^3) / 6.44953 * 10^{18} = 5.36836 * 10^{-8}$$

$$Energy_annual_con_perbit_injoule = Energy_annual_con_perbit * 60 * 60 \quad (8.10)$$

$$Energy_annual_con_perbit_injoule = 5.36836 * 10^{-8} * 60 * 60 = 1.93 * 10^{-4}$$

8.3 Power Calculation after Energy Saving Features

The previous section calculated energy per bit without considering the power savings features. In this section the same model is followed but taking into account the following energy saving features.

8.3.1 PSI

This feature is currently applicable only for RUA. The number of radio units decrease when the user activity is low. This feature does not affect the DUs and the calculations would be the same when there was no savings which is depicted in Table 6.10.

RU calculations are tabulated below in Table 8.6.

Table 8.6: Power Consumption of RU(2017) with PSI

Scenario	Activity	RUA (in units)	Power (per unit)	RUA Total power	RUB (in units)	Power (per unit)	RUB Total power
Super Dense	High	552	380	209760	276	250	69000
	Medium	4236	380	1609680	2118	250	529500
	Low	601	380	228380	0	250	0
Dense Urban	High	5298	380	2013240	2649	250	662250
	Medium	42162	380	16021560	21081	250	5270250
	Low		380	996360	0	250	0
Urban	High	2814	380	1069320	0	250	0
	Medium	8862	380	3367560	0	250	0
	Low	760	380	2888000	0	250	0
Sub Urban	High	576	380	218880	0	250	0
	Medium	972	380	369360	0	250	0
	Low	56	380	21280	0	250	0
Rural	High	822	380	312360	0	250	0
	Medium	1188	380	451440	0	250	0
	Low	612	380	232560	0	250	0

The cells in Table 8.6 that differ from Table 8.5 belong to every scenario with low activity except rural.

$$\text{Pow_DU}_{\text{PSI}} = 1306200 + 882000 = 2188200 \text{ W}$$

$$\text{Pow_RU}_{\text{PSI}} = 27410540 + 6531000 = 33941540 \text{ W}$$

$$\text{Tot_pow}_{\text{PSI}} = 2188200 + 33941540 = 36129740 \text{ W}$$

$$\text{Energy_annual}_{\text{PSI}} = (36129740 * 24 * 365) / 1000 = 316496522.4 \text{ kWh}$$

$$\text{Energy_annual_con_perbit} = (316496522.4 * 10^3) / 6.44953 * 10^{18} = 4.95143 * 10^{-8}$$

$$\text{Energy_annual_con_perbit_injoule} = 4.95143 * 10^{-8} * 60 * 60 = 1.78 * 10^{-4}$$

$$\text{Energy savings (in \%)} = (1.93 * 10^{-4} - 1.78 * 10^{-4}) / 1.93 * 10^{-4} = 7.77\%$$

8.3.2 Cell Sleep

The cells are put into sleep for one-third of the time duration. There is a power drain when components are in sleep mode which cannot be neglected. It has been found out that both RUA and RUB consume **81 W** when they are put to sleep.

Table 8.7 gives Timing scenario per day which is a means to evaluate cell sleep duty cycle.

Table 8.7: Timing Scenario per Day(24 hours)

Busy hour	Medium load	Low load
4	12	8

$$Cell_sleep_duty = Low_load / 24 \tag{8.11}$$

Case I: Cell Sleep has been switched OFF.

Energy consumed in the RU = 30480180 + 6531000 = 37011180 W from equation 8.2

Case II: Cell Sleep has been turned ON

Table 8.8 gives the power consumption of RUs when Cell sleep is turned ON but considers only those components which are active. The deactivated RUs are ignored.

Table 8.8: Power Consumption of Active RU with Sleep Mode ON(2017)

Scenario	Activity	RUA (in units)	Power (per unit)	RUA Total power	RUB (in units)	Power (per unit)	RUB Total power
Super Dense	High	552	380	209760	0	250	0
	Medium	2118	380	804840	0	250	0
	Low	1803	380	685140	0	250	0
Dense Urban	High	5298	380	2013240	0	250	0
	Medium	21081	380	8010780	0	250	0
	Low	7866	380	2989080	0	250	0
Urban	High	1407	380	534660	0	250	0
	Medium	4431	380	1683780	0	250	0
	Low	2280	380	866400	0	250	0
Sub Urban	High	288	380	109440	0	250	0
	Medium	486	380	184680	0	250	0
	Low	168	380	63840	0	250	0
Rural	High	411	380	156180	0	250	0
	Medium	594	380	225720	0	250	0
	Low	306	380	116280	0	250	0

Table 8.9 gives the power consumption of RUs when Cell sleep is turned ON but considers only those components which are **inactive**. Every inactive RU expends 81 W.

Table 8.9: Power Consumption of Inactive RU with Sleep Mode ON(2017)

Scenario	Activity	RUA (in units)	Power (per unit)	RUA Total power	RUB (in units)	Power (per unit)	RUB Total power
Super Dense	High	0	81	0	276	81	22356
	Medium	2118	81	171558	2118	81	171558
	Low	0	81	0	0	81	0
Dense Urban	High	0	81	0	2649	81	214569
	Medium	21081	81	1707561	21081	81	1707561
	Low	0	81	0	0	81	0
Urban	High	1407	81	113967	0	81	0
	Medium	4431	81	358911	0	81	0
	Low	0	81	0	0	81	0
Sub Urban	High	288	81	23328	0	81	0
	Medium	486	81	39366	0	81	0
	Low	0	81	63840	0	81	0
Rural	High	411	81	33291	0	81	0
	Medium	594	81	48114	0	81	0
	Low	306	81	24786	0	81	0

$$Pow_DU_{CS} = 1306200 + 882000 = 2188200 \text{ W}$$

$$Pow_RUA_{CSA} = \left(\sum_{i=1}^{15} RUA_i \right) * 380 \quad (8.12)$$

$$Pow_RUA_{CSA} = 49089 * 380 = 18653820 \text{ W}$$

$$Pow_RUB_{CSA} = \left(\sum_{i=1}^{15} RUB_i \right) * 250 \quad (8.13)$$

$$Pow_RUB_{CSA} = 0 * 250 = 0 \text{ W}$$

$$Pow_RUA_{CSI} = \left(\sum_{i=1}^{15} RUA_i \right) * 81 \quad (8.14)$$

$$Pow_RUA_{CSI} = 31122 * 81 = 2520882 \text{ W}$$

$$Pow_RUB_{CSI} = \left(\sum_{i=1}^{15} RUB_i \right) * 81 \quad (8.15)$$

$$Pow_RUB_{CSI} = 26124 * 81 = 2116044 \text{ W}$$

$$Pow_RUA_{CS} = Pow_RUA_{CSA} + Pow_RUA_{CSI} \quad (8.16)$$

$$Pow_RUB_{CS} = Pow_RUB_{CSA} + Pow_RUB_{CSI} \quad (8.17)$$

$$Pow_RUA_{CS} = 18653820 + 2520882 = 21174702 \text{ W}$$

$$Pow_RUB_{CS} = 0 + 2116044 = 2116044 \text{ W}$$

$$Act_Pow_RUCS = [Pow_RUCS * Cell_sleep_duty] + [Pow_RUnosav * (1 - Cell_sleep_duty)] \quad (8.18)$$

$$Act_Pow_RUA_{CS} = (21174702 * 0.333) + (30480180 * (1 - 0.333)) = 27381455.826 \text{ W}$$

$$Act_Pow_RUB_{CS} = (2116044 * 0.333) + (6531000 * (1 - 0.333)) = 5060819.652 \text{ W}$$

$$Pow_RUCS = 27381455.826 + 5060819.652 = 32437702 \text{ W}$$

$$Tot_pow_{CS} = 2188200 + 32437702 = 34625902 \text{ W}$$

$$Energy_annual_{CS} = (34625902 * 24 * 365) / 1000 = 303322901.5 \text{ kWh}$$

$$Energy_annual_con_perbit = (303322901.5 * 10^3) / 6.44953 * 10^{18} = 4.747173 * 10^{-8} \text{ Wh/bit}$$

$$Energy_annual_con_perbit_injoule = 4.747173 * 10^{-8} * 60 * 60 = 1.71 * 10^{-4} \text{ Joules/bit}$$

$$Energy \text{ savings (in \%)} = (1.93 * 10^{-4} - 1.71 * 10^{-4}) / 1.93 * 10^{-4} = 12.87\%$$

8.3.3 Lean Carrier

This is a power saving feature which does not reduce the number of units but curtails the power expense of each unit. This is given by the equation below.

$$LC_saving = 3.0\% * Pow_{RU} \quad (8.19)$$

$$LC_saving_{RUA} = 3.0\% * 380 = 11.4 \text{ W}$$

$$LC_saving_{RUB} = 3.0\% * 250 = 7.5 \text{ W}$$

Table 8.10 gives the power expenditure of RUs with the aid of Lean carrier.

Table 8.10: Power Consumption of RU with Lean Carrier(2017)

Scenario	Activity	RUA (in units)	Power (per unit)	RUA To- tal power	RUB (in units)	Power (per unit)	RUB Total power
Super Dense	High	552	368.6	203467.2	276	242.5	66930
	Medium	4236	368.6	1561389.6	2118	242.5	513615
	Low	1803	368.6	664585.8	0	242.5	0
Dense Urban	High	5298	368.6	1952842.8	2649	242.5	642382.5
	Medium	42162	368.6	15540913.2	21081	242.5	5112143
	Low	7866	368.6	2899407.6	0	242.5	0
Urban	High	2814	368.6	1037240.4	0	242.5	0
	Medium	8862	368.6	3266533.2	0	242.5	0
	Low	2280	368.6	840408	0	242.5	0
Sub Urban	High	576	368.6	212313.6	0	242.5	0
	Medium	972	368.6	358279.2	0	242.5	0
	Low	168	368.6	61924.8	0	242.5	0
Rural	High	822	368.6	302989.2	0	242.5	0
	Medium	1188	368.6	437896.8	0	242.5	0
	Low	612	368.6	225583.2	0	242.5	0

$$Pow_DU_{LC} = 1306200 + 882000 = 2188200 \text{ W}$$

$$Pow_RU_{LC} = 29565774.6 + 6335070 = 35900844.6 \text{ W}$$

$$Tot_pow_{LC} = 2188200 + 35900844.6 = 38089044.6 \text{ W}$$

$$Energy_annual_{LC} = (38089044.6 * 24 * 365) / 1000 = 333660030.7 \text{ kWh}$$

$$Energy_annual_con_perbit = (333660030.7 * 10^3) / 6.44953 * 10^{18} = 5.21755 * 10^{-8}$$

$$Energy_annual_con_perbit_injoule = 4.95143 * 10^{-8} * 60 * 60 = 1.88 * 10^{-4}$$

$$Energy \text{ savings (in \%)} = (1.93 * 10^{-4} - 1.88 * 10^{-4}) / 1.88 * 10^{-4} = 2.6\%$$

8.3.4 RU Micro Sleep

This feature enhances the efficiency of RUA alone and RUB remains unaffected.

$$Micro_sleep_saving = 12.0\% * Pow_{RUA} \quad (8.20)$$

$$LC_saving_{RUA} = 12.0\% * 380 = 45.6 \text{ W}$$

Table 8.11 gives the power disbursement of RUs compensated by RU Micro Sleep. It would be justified to state only about RUA as the outputs under RUB bear the same statistics tabulated in 8.10. But to give a complete picture the redundant data has been retained.

Table 8.11: Power Consumption of RU with Micro Sleep(2017)

Scenario	Activity	RUA (in units)	Power (per unit)	RUA To- tal power	RUB (in units)	Power (per unit)	RUB Total power
Super Dense	High	552	334.4	184588.8	276	250	69000
	Medium	4236	334.4	1416518	2118	250	529500
	Low	1803	334.4	602923.2	0	250	0
Dense Urban	High	5298	334.4	1771651	2649	250	662250
	Medium	42162	334.4	14098973	21081	250	5270250
	Low	7866	334.4	2630390	0	250	0
Urban	High	2814	334.4	941001.6	0	250	0
	Medium	8862	334.4	2963453	0	250	0
	Low	2280	334.4	762432	0	250	0
Sub Urban	High	576	334.4	192614.4	0	250	0
	Medium	972	334.4	325036.8	0	250	0
	Low	168	334.4	56179.2	0	250	0
Rural	High	822	334.4	274876.8	0	250	0
	Medium	1188	334.4	397267.2	0	250	0
	Low	612	334.4	204652.8	0	250	0

$$\begin{aligned} \text{Pow_DU}_{\text{MS}} &= 1306200 + 882000 = 2188200 \text{ W} \\ \text{Pow_RU}_{\text{MS}} &= 26822558 + 6531000 = 33353558.4 \text{ W} \\ \text{Tot_pow}_{\text{MS}} &= 2188200 + 33353558.4 = 35541758.4 \text{ W} \end{aligned}$$

$$\begin{aligned} \text{Energy_annual}_{\text{MS}} &= (35541758.4 * 24 * 365) / 1000 = 311345803.6 \text{ kWh} \\ \text{Energy_annual_con_perbit} &= (311345803.6 * 10^3) / 6.44953 * 10^{18} = 4.87157 * 10^{-8} \\ \text{Energy_annual_con_perbit_injoule} &= 4.95143 * 10^{-8} * 60 * 60 = 1.75 * 10^{-4} \end{aligned}$$

$$\text{Energy savings (in \%)} = (1.93 * 10^{-4} - 1.75 * 10^{-4}) / 1.93 * 10^{-4} = 9.33\%$$

8.3.5 RU Fast Power Level Change(FPLC)

This improvement influences both RUA and RUB equitably and there is a power saving of **15 W** in each entity.

Table 8.12 tabulates the power expense of RU with FPLC turned ON.

Table 8.12: Power Consumption of RU(2017)

Scenario	Activity	RUA (in units)	Power (per unit)	RUA To- tal power	RUB (in units)	Power (per unit)	RUB Total power
Super Dense	High	552	365	184588.8	276	235	69000
	Medium	4236	365	1416518	2118	235	529500
	Low	1803	365	602923.2	0	235	0
Dense Urban	High	5298	365	1771651	2649	235	662250
	Medium	42162	365	14098973	21081	235	5270250
	Low	7866	365	2630390	0	235	0
Urban	High	2814	365	941001.6	0	235	0
	Medium	8862	365	2963453	0	235	0
	Low	2280	365	762432	0	235	0
Sub Urban	High	576	365	192614.4	0	235	0
	Medium	972	365	325036.8	0	235	0
	Low	168	365	56179.2	0	235	0
Rural	High	822	365	274876.8	0	235	0
	Medium	1188	365	397267.2	0	235	0
	Low	612	365	204652.8	0	235	0

$$\text{Pow_DU}_{\text{FPLC}} = 1306200 + 882000 = 2188200 \text{ W}$$

$$\text{Pow_RU}_{\text{FPLC}} = 29277015 + 6139140 = 35416155 \text{ W}$$

$$\text{Tot_pow}_{\text{FPLC}} = 2188200 + 35416155 = 37604355 \text{ W}$$

$$\text{Energy_annual}_{\text{FPLC}} = (37604355 * 24 * 365) / 1000 = 329414149.8 \text{ kWh}$$

$$\text{Energy_annual_con_perbit} = (329414149.8 * 10^3) / 6.44953 * 10^{18} = 5.15172 * 10^{-8}$$

$$\text{Energy_annual_con_perbit_injoule} = 4.95143 * 10^{-8} * 60 * 60 = 1.85 * 10^{-4}$$

$$\text{Energy savings (in \%)} = (1.93 * 10^{-4} - 1.85 * 10^{-4}) / 1.93 * 10^{-4} = 4.15\%$$

Finally, the last two tables 8.13 and 8.14 sculpts the energy calculation (with-
out and with savings) in a nutshell and paints a very favourable outcome.

Table 8.13: Total Energy Calculation before Savings(2017)

2017			
		LTE	Site Trans
Power[W]	DU	2188200	325020
	RU	37011180	0
	Total	39199380	325020
Yearly Energy [kWH]		343386568.8	2847175
Yearly Energy [GWH]		343.3865688	2.847175
Total Yearly Energy [GWH]		347.598771	

Table 8.14: Total Energy Calculation after Savings(2017)

2017			
		LTE	Site Trans
Power[W]	DU	2188200	325020
	RU	24614040.31	0
	Total	26802240.31	325020
Yearly Energy [kWH]		234787625.1	2847175
Yearly Energy [GWH]		234.7876251	2.847175
Total Yearly Energy [GWH]		238.9998273	

$$\text{Energy_annual}_{\text{combined}} = (26802240.31 * 24 * 365) / 1000 = 234787625.1 \text{ kWH}$$

$$\text{Energy_annual_con_perbit} = (234787625.1 * 10^3) / 6.44953 * 10^{18} = 3.68453 * 10^{-8}$$

$$\text{Energy_annual_con_perbit_injoule} = 3.68453 * 10^{-8} * 60 * 60 = 1.33 * 10^{-4}$$

$$\text{Energy savings (in \%)} = (1.93 * 10^{-4} - 1.33 * 10^{-4}) / 1.93 * 10^{-4} = \mathbf{31.09\%}$$

In this section, the objective is to analyze the results in length and explain them in detail by comparing them to previous researches.

To improve the throughput and performance, tailor-made solutions were devised for each deployment scenario as cited in Chapter 4, but to strike a balance between performance and energy efficiency, a dedicated power model was used in conjunction with some energy saving features. Five different kinds of energy saving features were used to increase the efficiency without any significant compromise in the throughput. The traffic details were obtained from Ericsson Mobility report (2014) and only the LTE information was hand-picked which constituted 70% of the RAT deployment. One important observation was that our intent is to maximize energy efficiency which differs from total energy consumption. Over the years, the energy consumption has increased which is a result of more number of subscribers and is somewhat difficult to control; but the energy saving features helps us in decreasing the energy by keeping the parameters in check. So, it is logical to be more interested in energy consumed per bit. As a refresher, total energy consumption was calculated to be $1.93 * 10^{-4}$ annually. Before discussing in length the consequences of the power saving features there needs to be a clear picture about Traffic model and the Power model.

The Earth scenario picked up applies to European profile and using the same for Asian and North American profiles would not be a proper fit. The most important term determined from the traffic model is Bit-rate. Bit-rate is high in areas where the traffic is low and so it was the highest in rural areas. When efforts are being made to minimize energy consumption it should not be at the cost of the throughput. A minimum throughput has to be determined and energy saving features needs to be applied keeping that in mind. There is no need of having such a high bit rate in rural areas so power saving features can be used most effectively there.

The power model has been taken from the Earth model where the power of individual sub components has been calculated. The implementation and testing was done on an RBS which comprises of digital and radio units. Two types of each units have been used having different specifications, some suited for macro base station and some for micro. Macro BS is generally concerned in providing

coverage and the smaller BS provide capacity. Though both DUA and DUB have almost same power consumption, their purpose is different. DUA is used mostly in micros and picos and DUB is used in macros. The real savings was applied to RUs where it gets interesting. RUA has a much higher consumption than RUB. They can be used in any BS but the throughput performance of RUA is much superior. RUBs are almost non-existent in most of the scenarios but its low power consumption feature makes up for it.

In the below section, it has been discussed how the energy saving features affect the radio units.

9.1 PSI

This feature can be applied only in sites where the user activity is low. Replacing three RRUs with one while still keeping the same coverage is not possible in high user activity sites. As seen in Table 7.12, there are no RUBs in low activity regions so PSI is applicable for RUAs only. The number of RUAs in low activity regions is exactly one-third of the original radio units. Rural areas are unaffected by PSI because having one radio for three would adversely affect the coverage because of the large ISD.

The energy savings was 7.77% which is quite good as low activity is prevalent in 57% of the area and 12% of the subscribers.

9.2 Cell Sleep

The feature was applied to both RUA and RUB. Cell sleep can be applied to radio units which could be either active or inactive. The cell sleep feature applies only to capacity cells and not to coverage cells, that's why there is never an instance that all cells are inactive. Capacity cells are meant mostly to boost performance so they could be turned off when the requirement is low. In super dense scenario where activity is high, cell sleep generally should be avoided so it is tough to observe any power savings here. There aren't many capacity cells in low activity areas in the first place so there's no point in turning them off. It's only in medium activity regions where energy can be saved by switching to cell sleep as the remaining capacity cells could maintain the performance. This nature is same in dense urban areas. But in urban and sub urban areas capacity cells in high activity areas can also be turned off as the number of subscribers is not that high. Maximum savings can be seen in rural areas as this feature can be applied to all activity regions.

In the sleep mode there are no active RUB units so the total consumption is 0. The number of RUA units differ as shown in table 7.14 mostly influencing the rural areas. When the radio units are in sleep mode it still consumes energy which has been calculated to be 81 W. Another important observation is that cell sleep is turned on for one-third of the time duration and all RUB units are put to sleep.

Energy savings was 12.87%. Though not very effective in super dense regions, it has a significant contribution in rural and sub-urban region.

9.3 Lean Carrier

The number of radio units remain unchanged but each unit now consumes 97% of the power. The calculations show that 7.5 W is saved by RUB and 11.4 W by RUA.

Energy savings turned out to be 2.6%. Compared to other features it has less saving in percentage but it is important to note that this feature is directly proportional to the number of units deployed. In years to come when there will be a need to increase the number of units, the savings would increase considerably especially in rural areas. Also, because it is independent of the scenario and activities this feature comes handy in city centers as it reduces the power even when high performance is needed and other features are rendered useless.

9.4 RU Micro Sleep

Most of the energy is used by the power amplifier(PA) so when PA is put to sleep there is a high expectancy that we save a lot. With Micro sleep feature ON, each unit now consumes 88% of the power.

But like PSI feature this only affects RUA. The total energy savings was 9.33%

9.5 RU FPLC

The feature was applied to both RUA and RUB just like Lean carrier. This brings the power consumption of the power amplifier to its minimum even when it is active. Each unit saved upto 15W. The energy savings was found out to be 4.15%

9.6 Tabulation

The first two features reduced the number of units and the last three features reduced the power consumption of each unit. The individual discussion on each feature in the previous section can be tabulated to see which feature works best in which scenario. The keywords stand for the impact level; the higher the impact, greater the possibility to save more power.

Table 9.1: Impact of Energy Savings for RUA

Scenario	Dense Urban			Urban			Rural		
	H	M	L	H	M	L	H	M	L
PSI	No	No	Avg	No	No	Avg	No	No	Avg
Cell sleep	No	High	No	High	High	No	High	High	High
Lean Carrier	Low	Low	Low	Low	Low	Low	Low	Low	Low
Micro sleep	Avg	Avg	High	Avg	High	High	High	High	High
FPLC	Low	Low	Low	Low	Low	Low	Low	Low	Low

Table 9.2: Impact of Energy Savings for RUB

Scenario	Dense Urban			Urban			Rural		
	H	M	L	H	M	L	H	M	L
PSI	No	No	No	No	No	No	No	No	No
Cell sleep	Low	Low	No	No	No	No	No	No	No
Lean Carrier	No	No	No	No	No	No	No	No	No
Micro sleep	No	No	No	No	No	No	No	No	No
FPLC	High	High	No	No	No	No	No	No	No

It is quite evident from the two tables 9.1 and 9.2 that the radio unit RUA plays a much significant role in power savings as RUB has no impact in most of the scenario-activity combinations. This is primarily because more than twice remote radio units of RUA are deployed compared to RUB and the RUBs are present only in super dense and dense regions where the activities are either high or medium. Another fact is RUA consumes more power than RUB so it enjoys higher priority that makes complete sense because reducing consumption of RUA is the most effective way of bringing the overall power consumption. Therefore, the overall impact of RUB to the energy efficiency matter fades in comparison to RUA but nevertheless it cannot be deemed irrelevant as it might play an important role in future. It consumes far less power compared to RUA and has higher percentage savings in dense urban scenarios when FPLC is in play. It would be wise to deploy more RUBs in the city center where the population density as well as the user activity is high.

Conclusions and Future Work

As a part of this project, the energy efficiency of LTE HetNets has been investigated. Numerous simulations have been carried out for HetNets comprising of a macro network complemented with small cells in order to replicate the German city chosen for this study. A network model was prepared that gave an account of LTE subscribers in a particular geographical region. And simulation was carried out to validate the throughput and energy performance. The addition of more cells hones the performance of the network but in the process tend to increase the power expenditure. But, more focus needs to be on pruning the energy consumption. The deployment of HetNets is a trade-off between energy consumption and performance. The results convey that the capacity and user experience in an LTE network (mostly dense urban) can be enhanced by deploying indoor small cells. This is because of the much improved performance of the small cells which acts as capacity cells for smaller areas and also due to offloading of the covering macro network.

With the rapid growth of subscriptions and demand for traffic in mind, it is justified to study the behavior of HetNets in such situations of higher traffic demand. The results are largely based on the Earth model and Ericsson Mobility report from where the population density, ISD and monthly data traffic has been acquired. The values picked are a result of extrapolations as it concentrates on the year 2017. Only those scenarios have been selected for study where there is a desirable improvement in energy savings. Every scenario is a creation of splitting countries into several smaller territories with varied population density and RAT deployment. It can also be observed that ISD is relatively much higher for suburban and rural scenarios compared to urban.

The calculations show that combining all the energy saving features together, energy savings close to 31% is possible which could be termed as a big achievement. Now, in a base station most of the power is used up by the DUs and the RUs. There are two different ways to devise a plan to achieve greater energy efficiency. The first is to reduce the number of units without compromising in the performance and the other method is to reduce the energy consumption in each unit. The energy saving features used in the calculation does not affect the DUs, but only the RUs. Two different kinds of RUs have been used RUA and RUB that have different power consumption. The functionalities of these features can

be considered to be independent of each other and may not apply to all scenarios. This is best comprehended by considering each feature separately. The PSI feature is currently applied only for RUA. In regions of low activity, PSI makes it viable to reduce the number of units and almost 8% of energy is saved. Cell sleep appertains to both RUA and RUB and pitting cells to sleep mode in regions of no activity saves a whopping 13% of the energy. LC feature saves 3% of energy and Micro sleep brings about a energy savings improvement of 9.33%. 4% energy is saved using FPLC. These features cannot be compared with each other as they all serve different purposes and heavily depend on the requirements. A thorough observation suggests that major advancements need to be done in dense urban scenario with medium activity as maximum power expenditure is found here. Cell sleep is a powerful feature which saves energy astronomically, but in super dense scenarios, it is impractical to switch this feature ON as it affects the user experience adversely.

In this study, the energy savings was compared for very different environments. Also, the total subscribers was approximated and arranged uniformly for the simulation purposes. Now this project could be a good background for future studies and investigations and can be applied to generic scenarios. There could be a number of other region-activity combinations and having a common model to represent them would be a ground-breaking work. Though it is convenient to employ all the features and save energy, it needs to be understood that every feature involves resources and cost of installation might be a nuisance. So every feature needs to be adopted based on the scenario to create a proper balance.

BEZT model was adopted for the simulations but there are other propagation models, which could be more appropriate. Some are better suited to indoor propagation but it has been omitted in this study. Also, to make the results more realistic, one could run simulations with indoor floor-plans consisting of rooms and hallways etc. Talking about simulations, static simulation is an effective method for estimating the potential for energy savings in a certain type of deployment, however these types of simulations can have certain drawbacks in terms of understanding the dynamic behavior of various sleep mode algorithms. Incorporating dynamic simulation might make it more complicated but it would provide a much realistic solution.

References

- [1] Travis Madsen, Frontier Group, Frank Gorke, MASSPIRG Education Fund, Rob Sargent, National Association of State PIRGs. *Energy Efficiency: The Smart way to reduce Global warming Pollution in the Northeast* (August, 2005)
- [2] Hannah Granade, Jon Creyts, Philip Farese, and Ken Ostrowski, *Energy efficiency: A compelling global resource, McKinsey Sustainability & Resource Productivity*
- [3] Markus Gruber, Oliver Blume, Dieter Ferling, Dietrich Zeller, *Alcatel-Lucent Bell Labs*, Germany, Muhammad Ali Imran, *CCSR, University of Surrey*, UK, Emilio Calvanese Strinati, *Commissariat à l’Energie Atomique*, France
- [4] <https://www.ict-earth.eu/>
- [5] Dietrich Zeller¹, Magnus Olsson², Oliver Blume¹, Albrecht Fehske³, Dieter Ferling¹, William Tomaselli⁴, and István Gdor^{2,1} Alcatel-Lucent, ²Ericsson, ³TU Dresden, ⁴Telecom Italia, *Sustainable Wireless Broadband Access to the Future Internet - The EARTH Project*
- [6] C. E. Jones, K. M. Sivalingam, P. Agrawal, J. C. Chen, *A survey of energy efficient network protocols for wireless networks*
- [7] A. Chandrakasan and R.W. Brodersen, *Low Power Digital CMOS Design* (Kluwer Academic, Norwell, MA, 1995).
- [8] Shad Roundy, Dan Steingart, Luc Frechette, Paul Wright, and Jan Rabaey *Wireless Sensor Networks* Volume 2920 of the series Lecture Notes in Computer Science pp 1-17, Power Sources for Wireless Sensor Networks.
- [9] S. Singh, C.S. Raghavendra and J. Stephanek, *Power-aware broadcasting in mobile ad hoc networks*, Technical report, Oregon State University, Department of Electrical and Computer Engineering (1999)
- [10] J. Postel, *Transmission control protocol*, RFC 793 (1981).
- [11] R. Cáceres and L. Iftode, *Improving the performance of reliable transport protocols in mobile computing environments*, IEEE Journal on Selected Areas in Communications 13(5) (1995) 850–857
- [12] M. Zorzi and R.R. Rao, *Energy efficiency of TCP in a local wireless environment*, Mobile Networks and Applications (2000)

- [13] Vincenzo Carrubba, M.Sc, *Novel Highly Efficient Broadband Continuous Power Amplifier Modes*, Chapter 1.5 OPERA-Net
- [14] *Optimising Power Efficiency in mobile Radio Networks (OPERA-Net)* EUREKA CELTIC project, <http://opera-net.org/default.aspx>
- [15] *Thomson Broadcast partners key industry actors in OPERA-Net 2 European project for the development of fully environmental friendly 4G networks*, March 15th, 2014 by Thomson-Broadcast
- [16] <http://www.celticplus.eu/Projects/Celtic-Plus-Projects/2011/OPERA-NET2/operanet2-default.asp>
- [17] *PANAMA (Power Amplifiers aNd Antennas for Mobile Applications)*, EUREKA CATRENE project, 2009-2011
- [18] *Energy Efficiency of linear power amplifiers for mobile telecommunication base stations (ELBA)*, BMBF research project, *Förderschwerpunkt "mobile-GaN"*, 08/2006 - 07/2009. <http://www.pt-it.ptdlr.de/de/1760.php>
- [19] *Class-S*, German research project in *BMBF Förderschwerpunkt "mobileGaN"*, 09/2006 - 02/2010. <http://www.pt-it.pt-dlr.de/de/1760.php>
- [20] *Spitzencluster COOL SILICON*, www.cool-silicon.de/
- [21] *'Green Radio – Sustainable Wireless Networks'*, February 2009, Core 5, Programme of Mobile VCE, Virtual Centre of Excellence in Mobile and Personal Communications Limited.
- [22] Shad Roundy, Dan Steingart, Luc Frechette, Paul Wright, and Jan Rabaey *Wireless Sensor Networks* Volume 2920 of the series Lecture Notes in Computer Science pp 1-17, Power Sources for Wireless Sensor Networks.
- [23] Bo Berglund, Jan Johansson, and Thomas Lejon, *High efficiency power amplifiers*, https://www.ericsson.com/ericsson/corpinfo/publications/review/2006_03/01.shtml.
- [24] <http://docslide.us/documents/power-consumption-rbs-ericsson.html>.
- [25] Robert R. Schaller, *MOORE'S LAW: past, present, and future*.
- [26] Prof. David B Payne, CTVR Trinity College Dublin, Ireland and Aston University, UK *How much node consolidation and what are the challenges?*
- [27] Erik Dahlman, Stefan Parkvall, and Johan Sköld *4G LTE/LTE-Advanced for Mobile Broadband*
- [28] Chris Johnson *LTE in Bullets*
- [29] *3rd Generation Partnership Project* Technical Specification Group Radio Access Network, Evolved Universal Terrestrial Radio Access (E-UTRA), Physical channels and modulation (Release 8)
- [30] Jea-Gabriel Remy, Charlotte Letamendia *LTE Standard*

- [31] Abd-Elhamid M. Taha, and Hossam S. Hassanein, Queen’s University, Canada, Najah Abu Ali College of Information Technology, UAE University, United Arab Emirates *LTE, LTE-ADVANCED AND WiMAX TOWARDS IMT-ADVANCED NETWORKS*
- [32] Marcel Noordman, *The role of small cells in heterogeneous networks*
- [33] *Heterogeneous networks – securing excellent mobile*, ericsson White paper
- [34] *Ericsson Mobility Report*, Ericsson, June 2016 <http://www.ericsson.com/ericsson-mobility-report>
- [35] *Wi-Fi in heterogeneous networks – an integrated approach to delivering the best user experience*, Ericsson, June 2013 <http://www.ericsson.com/res/docs/whitepapers/wp-wi-fi-in-heterogeneous-networks.pdf>
- [36] Christian Hoymann, Daniel Larsson, Havish Koorapaty, and Jung-Fu (Thomas) Cheng, *A Lean Carrier for LTE*, Ericsson, *IEEE Communications Magazine (Volume: 51, Issue: 2, February 2013)*
- [37] Ran Tao, Jie Zhang, Xiaoli Chu, Department of Electronic and Electrical Engineering, University of Sheffield, UK *An Energy Saving Small Cell Sleeping Mechanism with Cell Expansion in Heterogeneous Networks*
- [38] Xin Wang, Prashant Krishnamurthy, and David Tipper, Graduate Telecommunications and Networking Program, University of Pittsburgh, *Cell Sleeping for Energy Efficiency in Cellular Networks: Is it Viable?*
- [39] *Radio network energy performance: Shifting focus from power to precision*, February 18, 2014
- [40] *3GPP TR 36.814 v9.0.0, E-UTRA: Further Advancements for E-UTRAN Physical layer aspects*, Mar, 2010
- [41] *Radio network energy performance: Shifting focus from power to precision*, February 18, 2014
- [42] Claude Desset, Björn Debaillie, Vito Giannini et al., *Flexible power modeling of LTE base stations*, Wireless Communications and Networking Conference (WCNC), 2012 IEEE
- [43] *"EARTH project under european community’s seventh framework programme FP/2007-2013, grant agreement n 247733,"*
- [44] P. Frenger et al., *Reducing energy consumption in LTE with cell DTX*, IEEE VTC Spring, Budapest, Hungary, May 2011.
- [45] Anton Blomgren ,and Kasper Ornstein Mecklenburg *Energy Optimization of NGR Micro G1 B2/B25*
- [46] *RBS Description RBS 6102 DESCRIPTION 2/1551-LZA 701 6001 Uen AM*
- [47] *Alcatel-Lucent demonstrates up to 27 percent power consumption reduction on base stations deployed by China Mobile*. Press release, Mobile World Congress, Barcelona, February 17, 2009.

-
- [48] Oliver Arnold¹, Fred Richter¹, Gerhard Fettweis¹, Oliver Blume², ¹Vodafone Chair Mobile Communications Systems, Technische Universitat Dresden, ²Alcatel-Lucent Bell Labs, Lorentz street, *Power Consumption Modeling of Different Base Station Types in Heterogeneous Cellular Networks*

Abbreviations

3GPP	3rd Generation Partnership Project
ADC	Analog-to-Digital Converter
AI	Antenna Interface
AIR	Antenna Integrated Radio
BB	Baseband
CA	Carrier Aggregation
CAPEX	Capital Expenditures
CC	Component Carriers
CDMA	Code Division Multiple Access
CMOS	Complementary Metal-Oxide Semiconductor
CRS	Cell-specific Reference Signal
DAS	Distributed Antenna System
DL	Downlink
DPD	Digital Pre-Distortion
DTX	Discontinuous Transmission
DUG	Digital Unit GSM
DUL	Digital Unit LTE
DUS	Digital Unit all Standards
DUW	Digital Unit WCDMA
DwPTS	Downlink Pilot Time Slot
EARTH	Energy Aware Radio and netWork tecHnologies
ECIs	Energy Consumption Indices
eSS	extended Synchronization Signal

FDD	Frequency Division Duplex
FDMA	Frequency Division Multiple Access
FEC	Forward Error Correction
FPLC	Fast Power Level Change
FPGAs	Field Programmable Gate Arrays
GOPS	Giga Operations Per Second
GP	Guard Period
GSM	Global System for Mobile Communication
HetNet	Heterogeneous Network
HSPA	High Speed Packet Access
IBW	Instantaneous Bandwidth
ICT	Information and Communication Technology
ISD	Inter-site Distance
LC	Lean Carrier
LNA	Low-Noise Amplifier
LTE	Long Term Evolution
MBMS	Multimedia Broadcast Multicast Service
MCPAs	Mutli-Carrier Power Amplifiers
MIMO	Multiple Input Multiple Output
MP	Multiprocessor
mRBS	micro Radio Base Stations
mRRUs	micro Remote Radio Units
MSMM	Multistandard Mixed Mode
NLOS	Non-Line of Sight
OFDM	Orthogonal Frequency Division Multiplexing
OFDMA	Orthogonal Frequency Division Multiple Access
OPERA	Optimising Power Efficiency in mobile RA
Net	Diagrams
OPEX	Operational Expenditure
PA	Power Amplifier
PDCCH	Physical Downlink Control Channel
PDSCH	Physical Downlink Shared Channel
PRACH	Physical Random-Access Channel

PRB	Physical Resource Blocks
pRBS	Pico Base Stations
PUSCH	Physical Uplink Shared Channel
PUCCH	Physical Uplink Control Channel
QoS	Quality of Service
RAN	Radio Access Network
RAT	Radio Access Technology
RB	Resource Block
RBS	Radio Base Station
RF	Radio Frequency
ROI	Return of Investment
RRH	Remote Radio Head
RRU	Remote Radio Unit
RRUS	Remote Radio Unit all Standards
RSRP	Reference Signal Receive Power
RSRQ	Reference Signal Receive Quality
RUG	Radio Unit GSM
RUS	Radio Unit all Standards
SIMO	Single Input Multiple Output
SINAD	Signal-to-Noise and Distortion Ratio
SON	Self-Organizing Network
SoTA	State of The Art
SRS	Sounding Reference Signal
TCP	Transmission Control Protocol
TCU	Transport Connectivity Units
TDD	Time Division Duplex
TDMA	Time Division Multiple Access
TRX	Transceiver
TTI	Transmission Time Interval
UL	Uplink
UMTS	Universal Mobile Telecommunications System
UpPTS	Uplink Pilot Time Slot
VGA	Variable-Gain Amplifier
WCDMA	Wideband Code Division Multiple Access