

## Design, servo motor selection and control implementation of the Agile Parallel Kinematic Manipulator

*The industry of today is yearning for faster, cheaper and more agile solutions for production and packaging. A lot of the concepts of today's robots were developed in the 80's. Since then, a lot has happened both software and hardware wise within robotics, but the base concepts have mostly been the same. The AgilePKM aims to disrupt the market with its innovative design.*

There are three basic types of robots commonly used in the industry: articulated, Selective Compliance Assembly Robot Arm (SCARA) and delta.



*Examples of articulated, SCARA and delta robot.*

The **articulated robot** has many similarities with a human arm. It has its motors working in **series** and its main advantage is having a large working space. They mostly have six axes making it possible for the robot to reach any point in any direction within the working space. One downside is that this robot carries not only the external loads, but also its own motors. This makes the robot's **moment of inertia** unnecessarily high.

The **SCARA robot** is a specific type of articulated robot with usually three axes. It is mostly used in assembly lines for tasks such as simple assembly or simple pick-and-place operations. It also carries its own motors causing a high moment of inertia.

The **delta robot** does not have its motors in series but in **parallel**. This makes it possible to place all motors in the base of the robot. Since the robot will have to move very little

of its own mass, it is very quick and particularly suited for fast pick-and-place tasks. Some of the downsides are that it has to be mounted in the ceiling taking up a lot of space and it has a limited working space.

The Agile Parallel Kinematic Manipulator (**AgilePKM**) aims to take the pros of each of these types and minimize the cons. The goal of the design is to place all motors in the base in order to keep the **moving mass low** and also keep the joints serially connected in order to **increase the working space**.

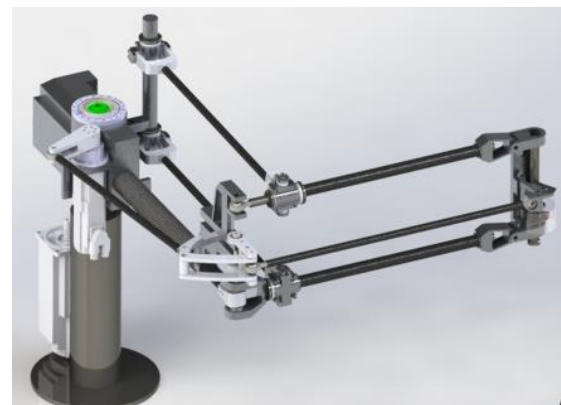

*CAD-model of the AgilePKM in its early stages*

When designing the first prototype of the AgilePKM there are many aspects to consider and they are all affecting each other. Acceleration of up to **15 g** is needed to compete with the fastest SCARA and delta robots. The high acceleration sets high demands on the mechanical components and servo motors as well as the programmer. The tasks handled in this

article are the elbow, servo motors and the automation platform.

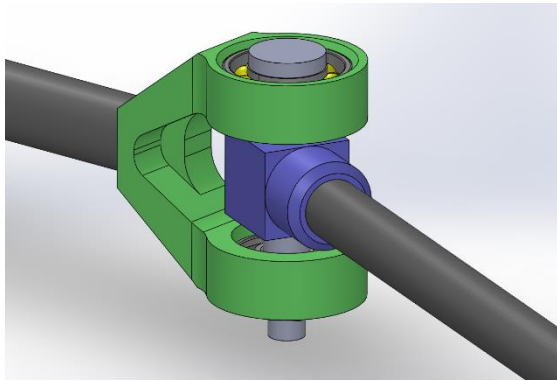

*The final design of the elbow*

The “**elbow**” is a crucial component of the AgilePKM as it actuates both vertical and horizontal movements. Its implementation is particularly interesting mechanically since the joint axle is rotated in vertical movement which is uncommon for single degree of freedom joints in robots. The task of withstanding the loads from the high accelerations of the test cycle, and at the same time incorporating a **compact** and **lightweight design**, is a challenge. An efficient design is reached by benchmarking solutions for similar hinge joints and generating new concepts adapted for the AgilePKM. The final design consists of a custom front and base designed for manufacturability, an adjusted bearing arrangement with two standard angular contact ball bearings and a precision pivot pin paired with a lock nut. The identified needs of the elbow are fulfilled but the final prototype is not physically manufactured since the AgilePKM is not fully designed yet. Instead it is verified by a finite element analysis simulating the worst case loads from the test cycle.

**Servo motors** are chosen in such a way that a standard test cycle can be completed incredibly quickly. This implies **high torque** on the servo motors. Should the test cycle be run at maximum speed multiple times in rapid succession, the motors will break due

to overheating. Hence the test cycle is only a measurement of the **maximum performance**. The chosen motor, MS2N04-D0BQ from Bosch Rexroth, will be able to complete the test cycle within competitive time frame.

When **programming** a new type of robot there are many things to consider. In the thesis the **kinematics** of the robot is calculated and explained. Kinematics is the description of motion for system of bodies, using equations to determine required joint angles to reach a certain position. Since the robot incorporates both serial and parallel kinematics, suitable kinematics does not exist and has had to be developed. The robot also has proper **restrictions** implemented in order to avoid moving outside of the mechanically restricted working space. In addition to this, restrictions for the acceleration of the end effector is also needed in order to stay within reasonable forces for the mechanical construction. There have been some problems in limiting the acceleration dynamically, which is proposed as future work.

In conclusion the project has been quite successful. The design of the elbow and the selection of servo motor have met the demands and suits current design of the AgilePKM well. The automation platform has been implemented and is able to control the AgilePKM once the prototype is built. Future work includes a redesign of the elbow and reselection of servo motors based on new loads from simulations of the test cycle. This, along the implementation of dynamic restrictions in the automation platform, will further optimize the prototype and ensure competitiveness with the exciting robots on the market.