

# Bachelor Project

Tom Lunde

2019



LUND UNIVERSITY

Framing of Clothes

Tom Lunde

Degree Project for Bachelor of Fine Arts in Design

Main field of study Industrial Design

From Lund University School of Industrial Design, Department of Design Sciences

Examiner: Professor Claus-Christian Eckhardt

Supervisors: Professor Claus-Christian Eckhardt, Lecturer Anna Persson, Senior Lecturer Jasjit Singh, Senior Lecturer Charlotte Sjödel

2020

ISRN: LUT-DVIDE/ EX--19/50440-SE



LUND UNIVERSITY

# Framing of clothes

Page	Subject	Page	Subject
05	Abstract	28	Size & dimension
06	Background	30	Materials & treatment
08	Brief	32	Details
09	Mind map	35	Add-ons
10	Research	36	Final product
18	Mood board	42	Conclusion
20	Sketching	43	Technical drawing
22	Framing	44	References
26	Mockups		



# Abstract

Det här projektet handlar om att vi ska ta tillvara på de kläder vi har och att vi ska kunna uppskatta dem, även när vi inte använder dem. Genom att ta ut plaggen från där de är förvarade och rama in dem, kan man även använda dem som en del av inredningen i våra hem. Detta har gjorts genom en designprocess där jag har undersökt och utvecklat vårt sätt att förvara kläder, grundat på den klassiska möbeln herrbetjänt. Projektet resulterade i en modern tappning av en herrbetjänt som är ett tredimensionellt ramverk som hängs på väggen, skapar en ram runt det som hängs i den och därmed riktar fokus på plagget.

This project is about taking care of the clothes we have and that we should be able to appreciate them, even when we do not use them. By bringing them out from where they are stored and frame them we can also use them as part of the interior of our homes. This has been done through a design process in which I have investigated and developed our way of storing clothes, based on the classical valet stand. The project resulted in a modern take of a valet stand, which is a three-dimensional framework that is hung on the wall and which creates a frame around the garment placed in it, focusing on the piece.

# Background

Today, clothing is a big factor in our lives. It is through clothing that we express who we are and our personality. Everyday we come across advertising, articles and social media accounts about clothes and fashion. Today people tend to view clothes as a consumable product, leading to a large impact on the climate. With that in mind,

along with the fact that good clothing management prolongs the garments life and an old valet stand the idea of creating a modern version of the valet stand, to bring life to the idea of caring for our clothes. Given that many of our garments also can cost quite a lot of money, you may also want to take good care of them.

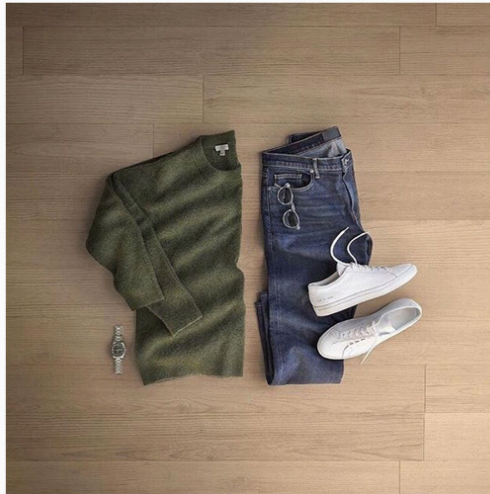

Image 1

Screenshot of Orgnals instagram page.

# Brief

“

Today we spend a lot of money on fashion and we express ourself through how we dress on the streets and in our everyday life. But when we come home we put away the clothes into a wardrobe. I want to bring out the clothes from where they are stored and make them into a part of the interior in our homes and that way being also able to show who we are in the homes.

# Mind map

I started my project with a mind map where I examined different parts of my idea and got a clearer look over what I wanted to do. In the mind map I could see that there are several different garments that may need to be evaluated. The target group, design and materials as well as functions were categories that were also covered by the mind map.

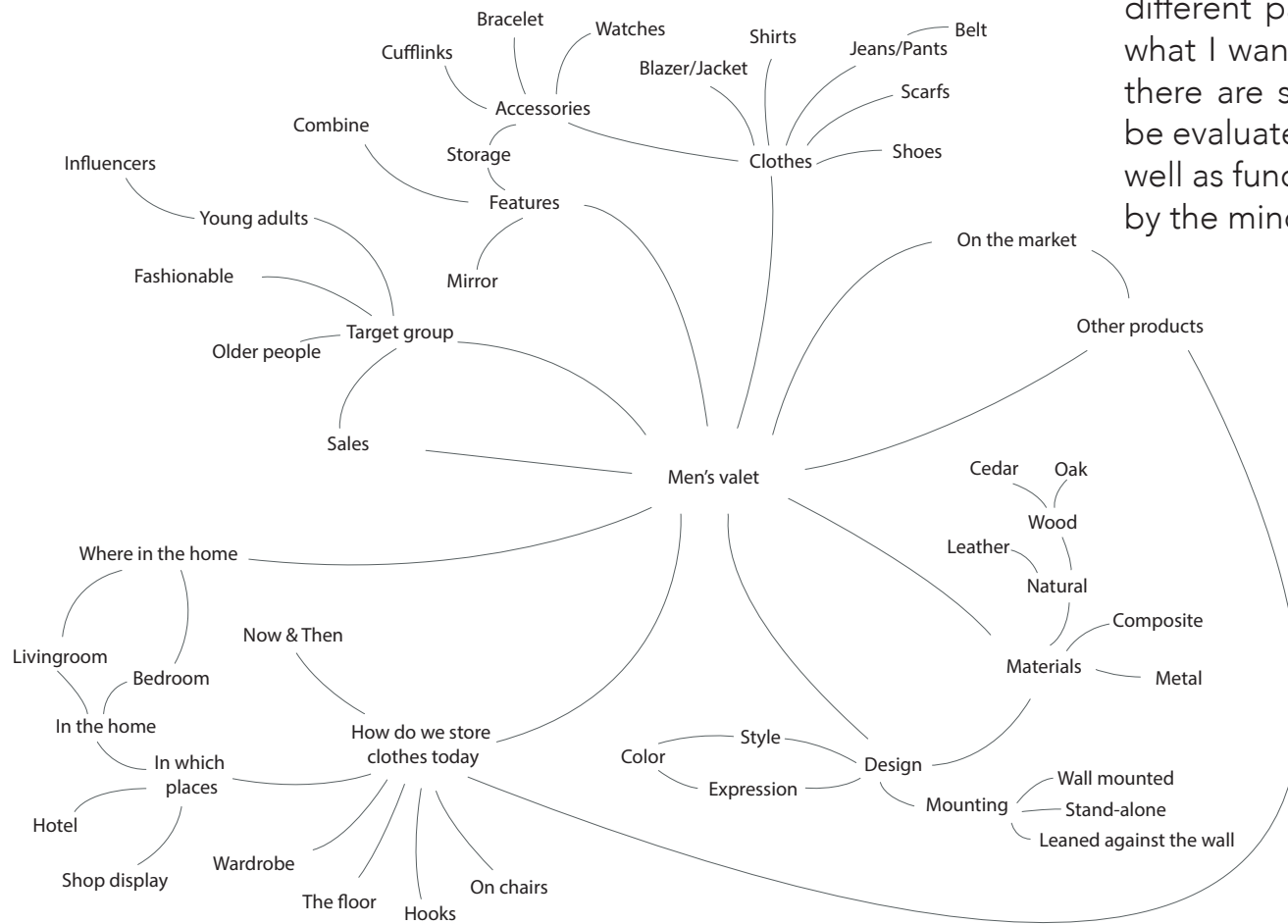



A photograph of a bedroom. In the center, a black and white French Bulldog sits on a bed with a blue and white striped duvet. To the left, a large green plant in a white pot sits on a wooden nightstand. In the background, a window with white frames looks out onto a building. On the windowsill, there are several items: a book titled 'HARUKI URAKAMI', a small potted plant, a jar, and a framed picture. The lighting is soft and natural, coming from the window.

# Research

“  
1 in 3 people all over the world say there are places where they feel more at home than the space they live in.

- IKEA life at home report 2018

10





Image 2

## IKEA Life at home report

Every year IKEA releases a report about peoples living situations around the globe and have been doing so for the past years. In the report, which has interviewed over 22 000 people, they came up to that almost one third of the people interviewed in the report said that they felt more at home in another place than where they lived<sup>1</sup>. This is something I found very interesting. I feel that ones home should reflect who you are and that is ones personal space on this earth.

# Other products

There are many different ways to store clothes outside the closet. I researched what different types of valet stands there are and also similar products. The different types range from more classic looking valet

stands to clothing racks that can accommodate many garments. There are also those who experiment with combining common things to store clothes on, such as a chair, with a valet stand.





Image 3

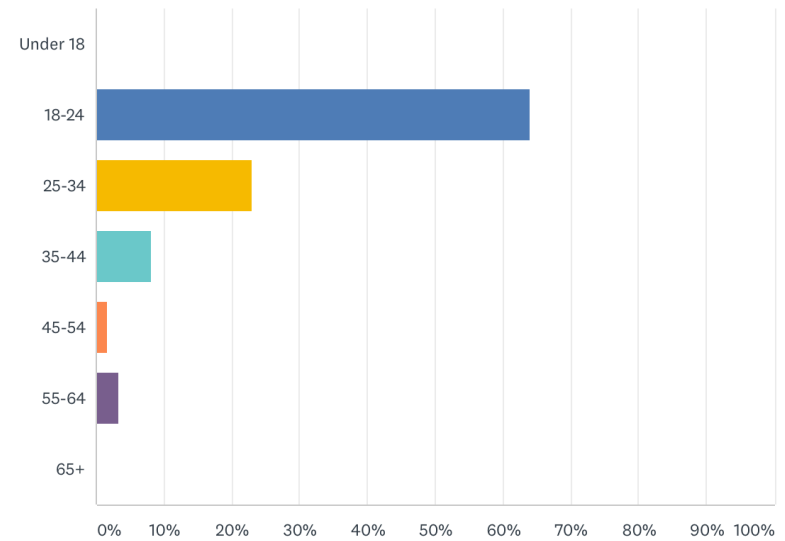

Image 4

# My survey

In order to get a picture of peoples clothing habits and how they stored their clothes I conducted a survey til which I received 61 answers. The survey consisted of a variety of questions, for example if they are required to have specific work outfit or not, and where in the home they store the most clothes outside of its original place.

What is your age?



What is your gender?

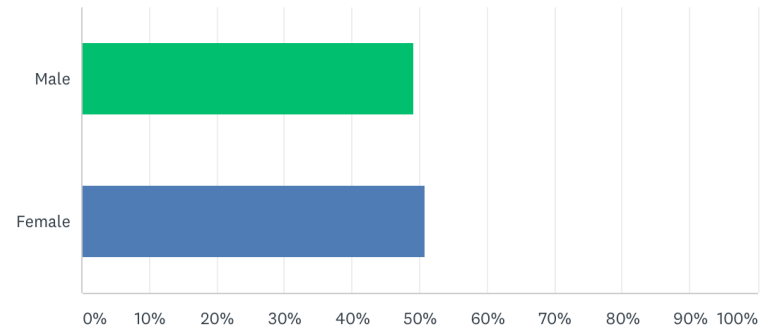

### What do you do?

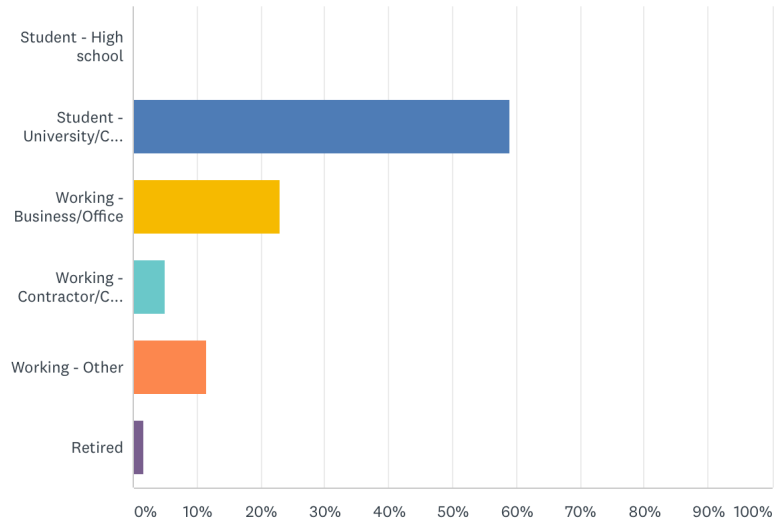

### Do you need to wear special clothes in what you do?

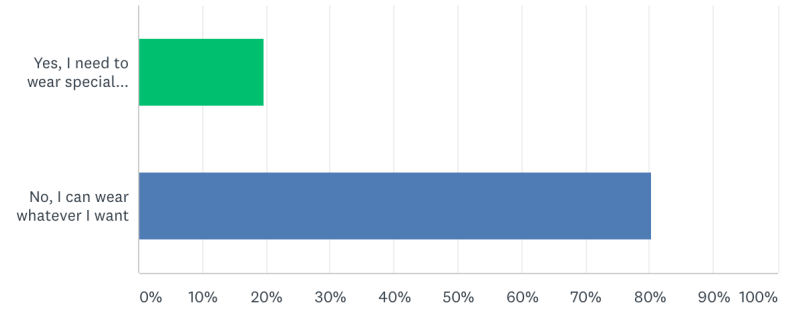

### Do you think it is important to take care of your clothes?

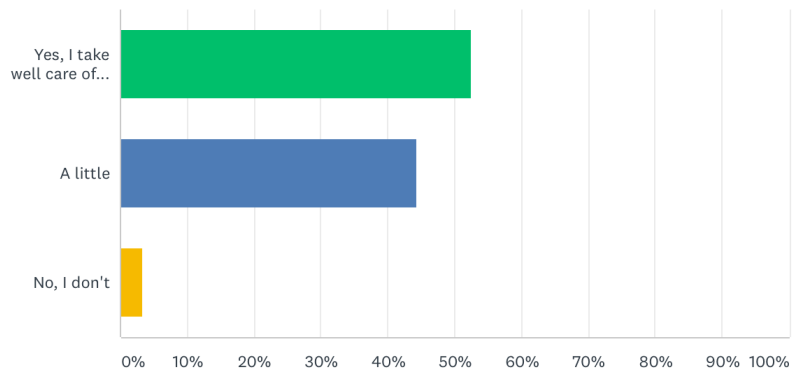

### How do you store your clothes?

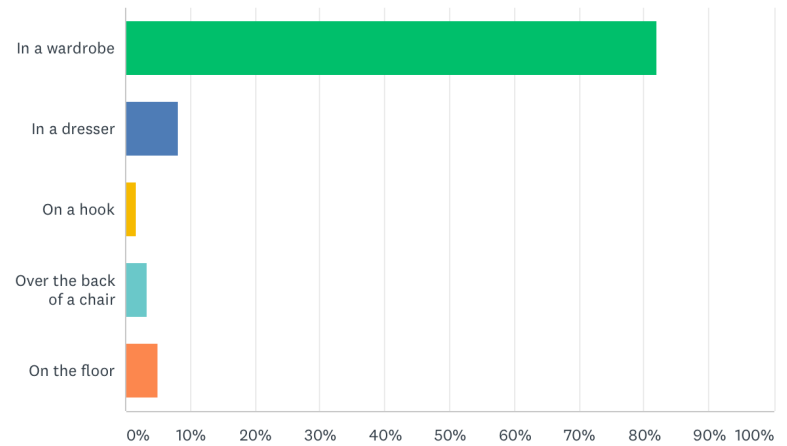

In which part of the home does the clothes that are not in the wardrobe/dresser end up?

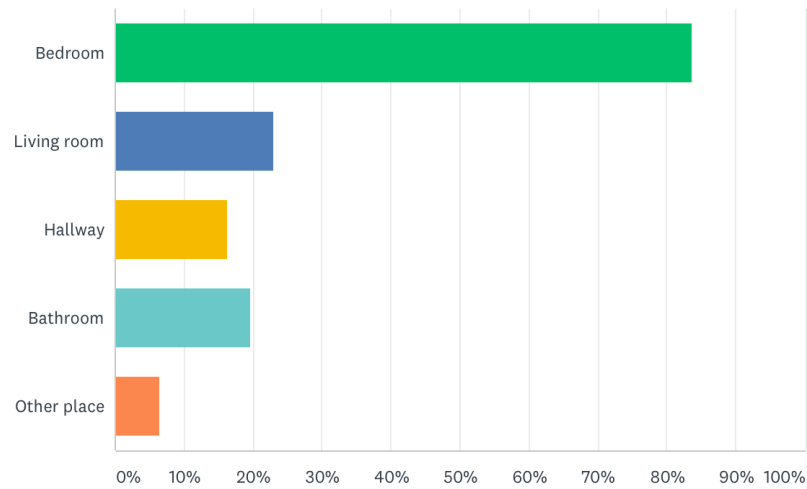

Do you test multiple combinations of clothes before you decide what to wear?

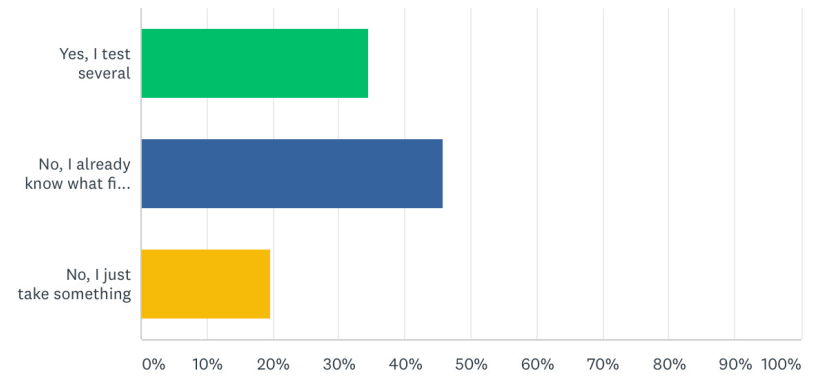

Do you hang out your clothes the day before you using them?

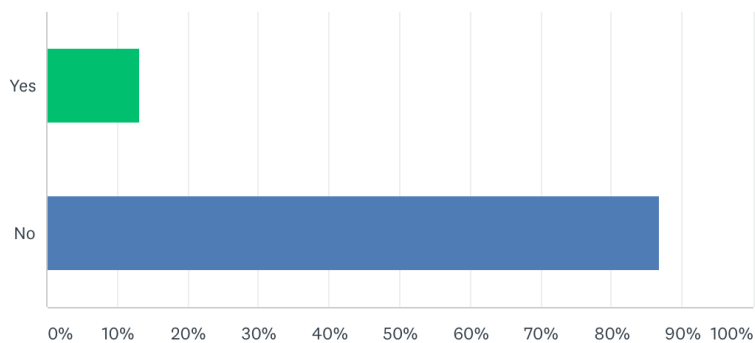

Do you have any kind of valet stand (herrbetjänt) in the home?

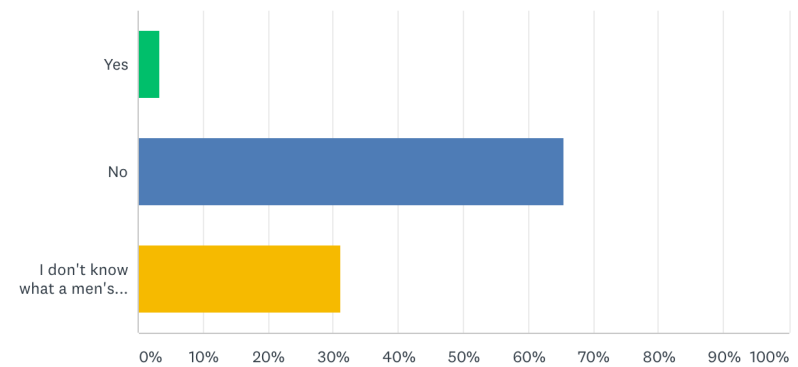

# Survey summary

From the survey I could read that the people who had answered it did not have any greater knowledge or use of a valet stand, and that most of the clothes were

stored in the bedroom. With the help from the survey I could set up a couple of criterias for the product. I could also focus on a target group of young adults.







The inspiration that I choose to continue with were more of the industrial and modern looking objects. They had a heavy yet rigid feeling to them but also very simple and sleek and which also were eye-catching.

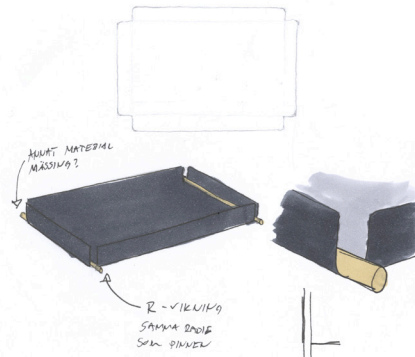
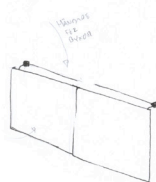
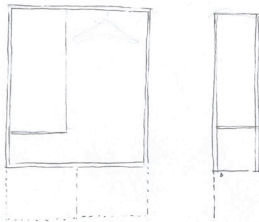
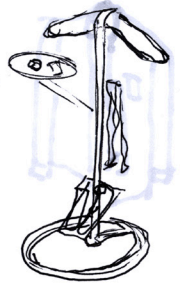
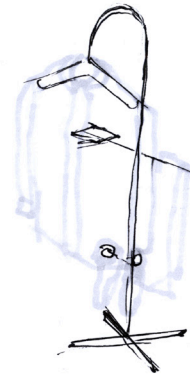
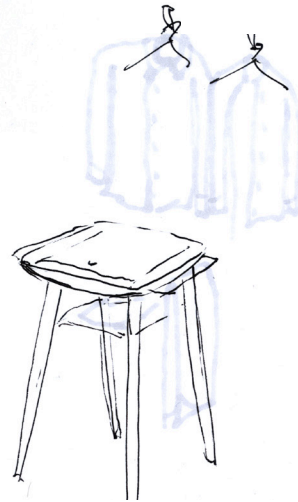
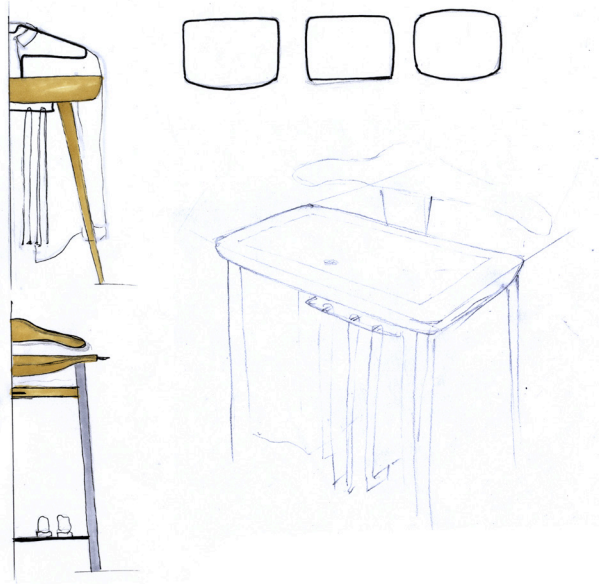
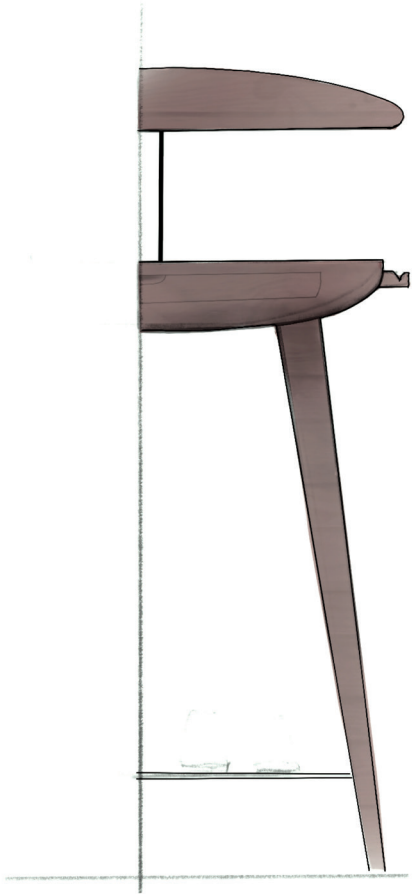



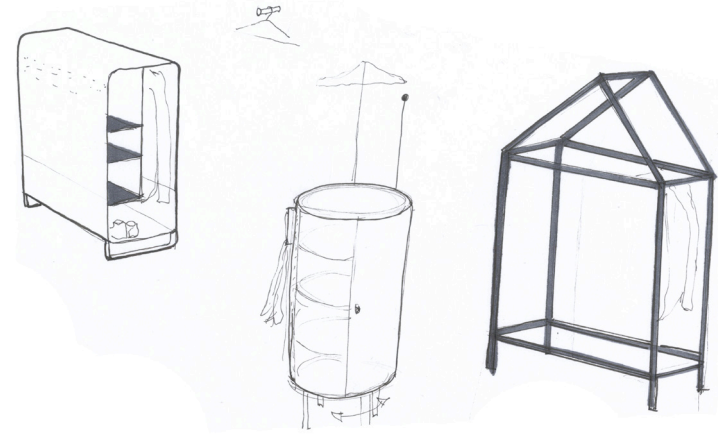
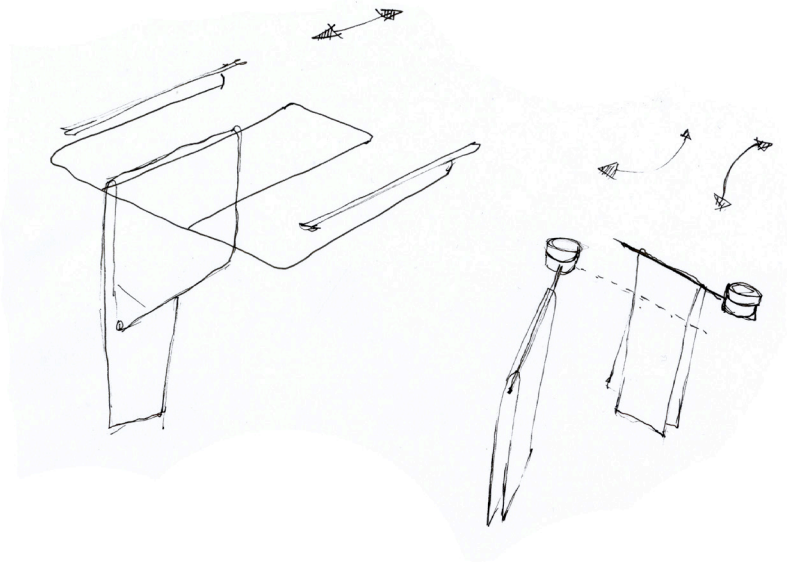

# Sketching

In the sketching process I began to explore the more traditional style of the valet stand where a shirt or jacket is ment to be hung on a fixed hanger. I added different types of features to add more usability, such as an extendible holder for jeans and trousers.

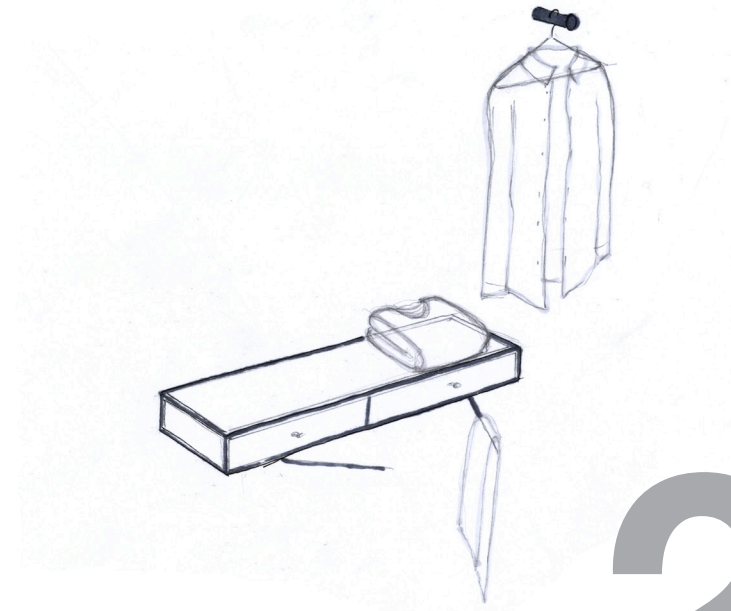

# Framing

During a discussion with a fellow student, Johan Skoogh, we discussed the concept of framing<sup>2</sup>. We talked about what we are framing, why we are framing it and how we do so. Asking questions as 'What do you want to show and what you want to hide?'

We agreed on that things that we like and have sentimental value to the user tend to get a specific placement in our homes. This lead to the idea of taking my valet stand and making it wall-hung.



As we all know, the difference in sizes in clothes can vary a lot. After deciding that it would be wall-hung because of the framing concept, I began to check what we are hanging on the walls and its sizes to have something to compare with. The most obvious are paintings and picture frames. Posters and frames come in standard sizes of up to frames of 70x100cm. To test this I taped a rectangle with the dimensions



where I hung up clothes of different sizes to see how they fitted inside the frame. If you put a frame around an object, it gets a specific place, otherwise it can have a feeling that it's "floating" when hung on the wall. As I didn't want my product to be too big and bulky but more sleek and elegant using an simple frame would be both elegant and bringing focus to the garment.

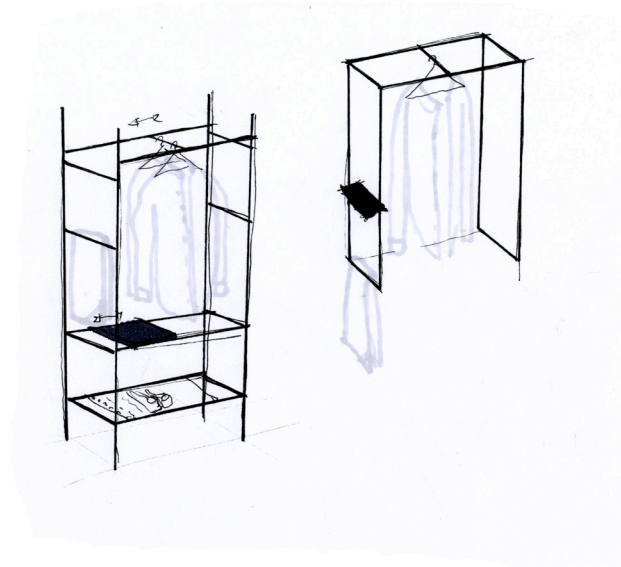
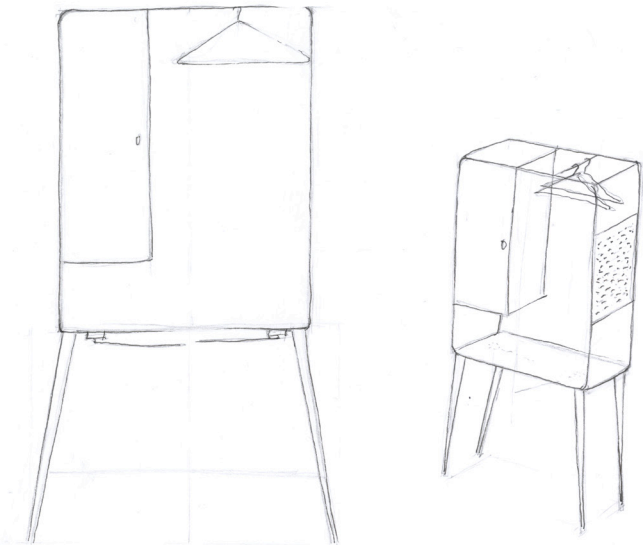

I started over with my sketching process and focused on the framing-concept.

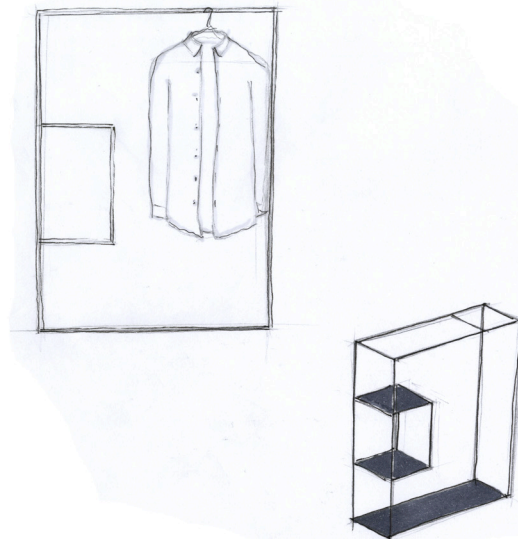

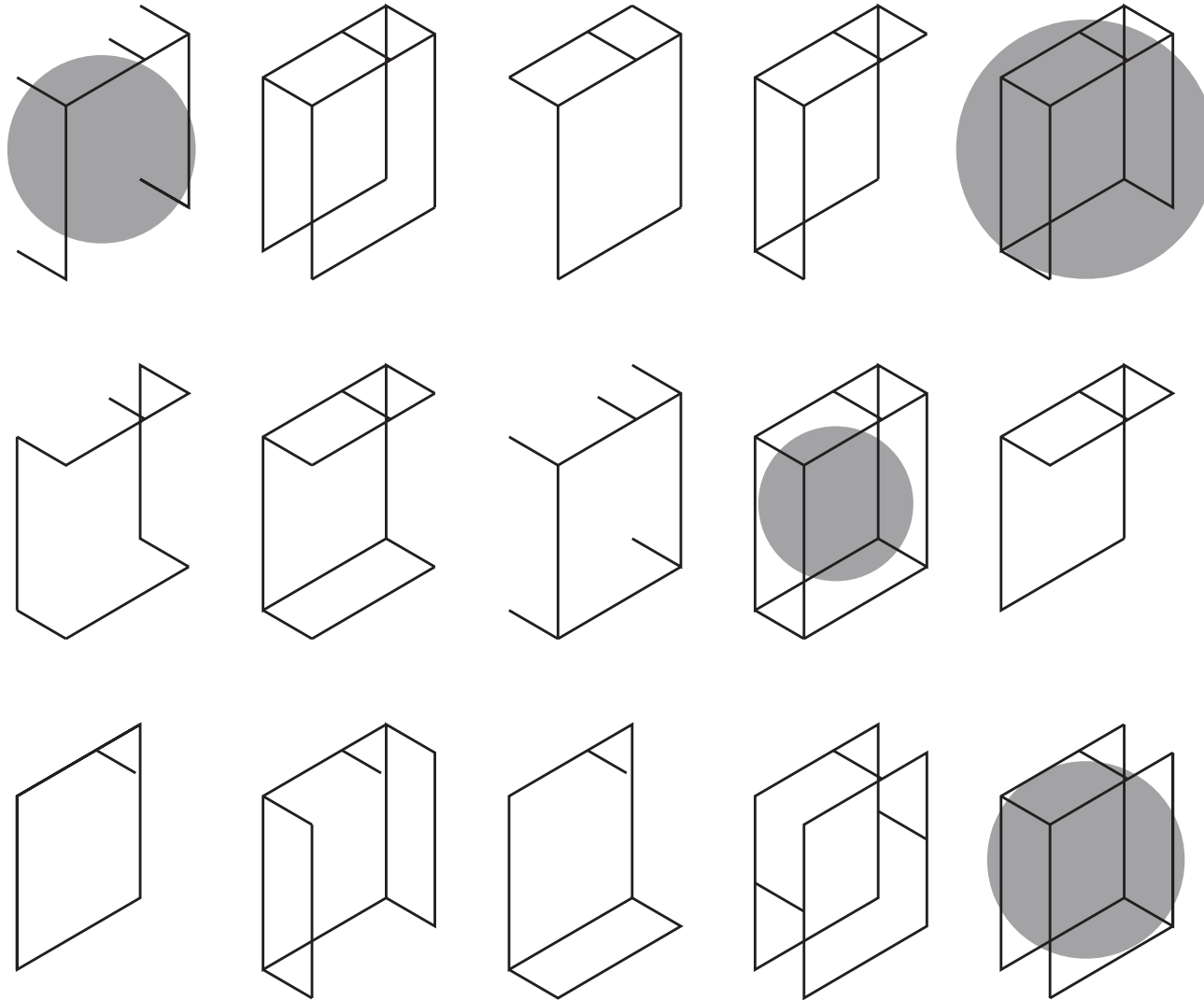

I played around with equal variations of a three-dimensional rectangle that came to be the foundation of my product.

I selected my favorite variations and brought them in to the modeling phase.



# Mockups

I started making small-scale mockups to get a better perception of the designs. I decided that alternative three would be the best design to move on with as it gave the opportunity to have the easiest access for longer garments to be hung in it and still keep the illusion off the frame.

The next step would be to make a full scale model in order to be able to test it with different features and also to get more insights on eventual improvements.



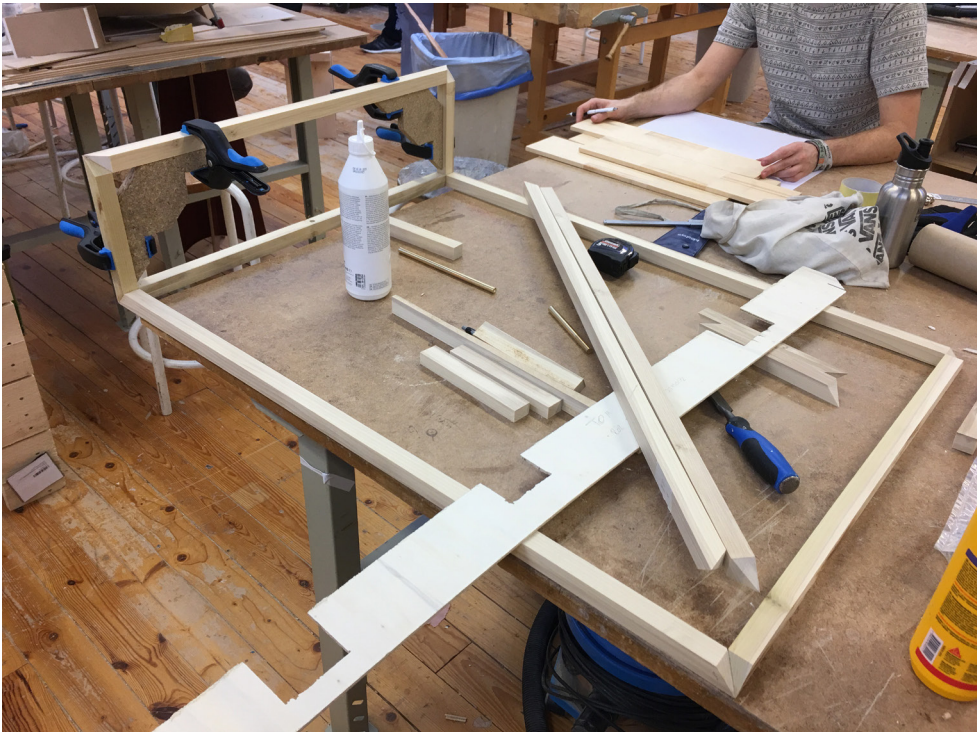

Scale 1:1 model making.







70cm

100cm



72cm

100,5cm

The hanger compared with a 70cm x 100cm frame.

28



# Size & dimension

In order for the frame not to look too big compared to other things on the walls, I chose to try to keep the dimensions of the frame so close as possible to the frames that exist. As mentioned before, the largest frames for prints usually come in the size of 70x100cm. It was this size that I started with and to test. In a frame of that size, a larger jacket could easily be fit without sticking through the frame or hanging too close to the side. The final dimension of the frame became 72cm wide, 100.5cm high and 23cm deep. The depth means that the frame is deep enough to fit two garments in the frame, but it would not protrude from the wall more than a regular shelf. The lim-

ited depth also means that there is a limited space in the frame, which means that you cannot hang too many garments in the frame because it is only intended for one or two garments to be hung in it.

Another reason I chose to use the proportions of existing frames is because the proportion of that type of rectangle is convenient for the eye to look at.

The frame consists of 24mm square sticks. 24mm was the optimum thickness I came up with. I tested similar thicknesses but they gave the impression of being either too thin or too thick.

# Material & treatment

From the beginning, my idea was that the valet stand would be made out of metal, based on the inspiration I had chosen to continue with from my mood board. The good properties of metal is that it is a strong material that can be processed and shaped in many different ways. When I made my full-scale model, I used the tree type poplar. With that, I realized several advantages of using wood over metal as material in the frame. For example, wood is much lighter which makes it much easier to hang it on the wall compared to a metal

frame. Wood is also cheaper material than metal. I chose to leave metal as a material and continue with wood.

I started to research wood and decided that I wanted to use oak as the type of tree in the frame. This is because oak is a sought after tree species that has been used for several hundred years and that I also find oak to have a very beautiful color and texture. For this reason, I also chose to leave the wood untreated just to preserve its color and texture.

I chose oak because it is a sought after material that is often used in furniture carpentry and frames. The oak's toughness also makes it very adaptable to use for the type of design the frame has.



Image 7

# Details

For the details like hooks and hangers, I chose brass as the material. This is because the gold-colored appearance of the brass fits well with the oak.

## Rod & hanger

To create a more uniform feel, I created a matching hanger for the frame in brass and oak. This is partly to give the clothes a good hanger to rest on but also that the user would not use a plastic hanger or similar in the frame which would reduce the elegance factor of the valet stand.

To indicate where to hang the hanger and to prevent it from moving, there is a clear notch that goes around the entire rod. But on the top, there are two hidden notches that allow more hangers to be hung. But since the product is intended for one garment at a time, it is the middle notch that is most obvious, but the alternative to hang additional garments is given with the hidden notches.





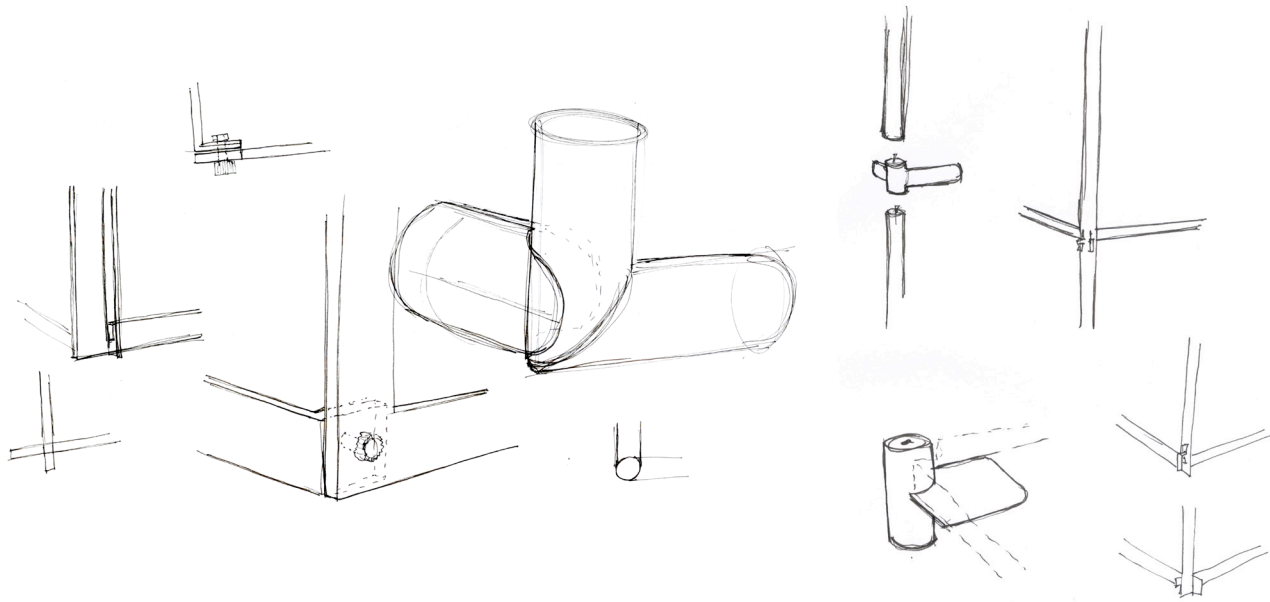

## Joinery

I sketched out many different suggestions on how to merge the different parts of the frame. At first, I tested different in metal but couldn't really find any that had not been made before or was similar to any other product. Once I had decided to move on with wood as a material, it became a new process to come up with a joint that fitted. I chose to do some tests where alternative number one became my obvious choice. This is because it is the most stylish and elegant alternative that gives stylish 45 degree corners from all directions and that it is also what would attract the least attention from the garment that should hang in the frame. The 45-45 corners also provides larger surface areas to glue on which means that there would not require any screws or bolts in the construction of the frame, only solid wood.



# Hook

During the process, I sketched out different ideas for accessories for the frame. Finally, I came to the conclusion that a couple of simple hooks were the best option. The hooks would be attached to the back of the front of the frame with keyhole shaped holes that allow the hooks to be moved if desired. By putting the hooks on the back, they do not interfere with the simple front of the frame but still provide the possibility for the user to hang, for example, jewelry or similar.

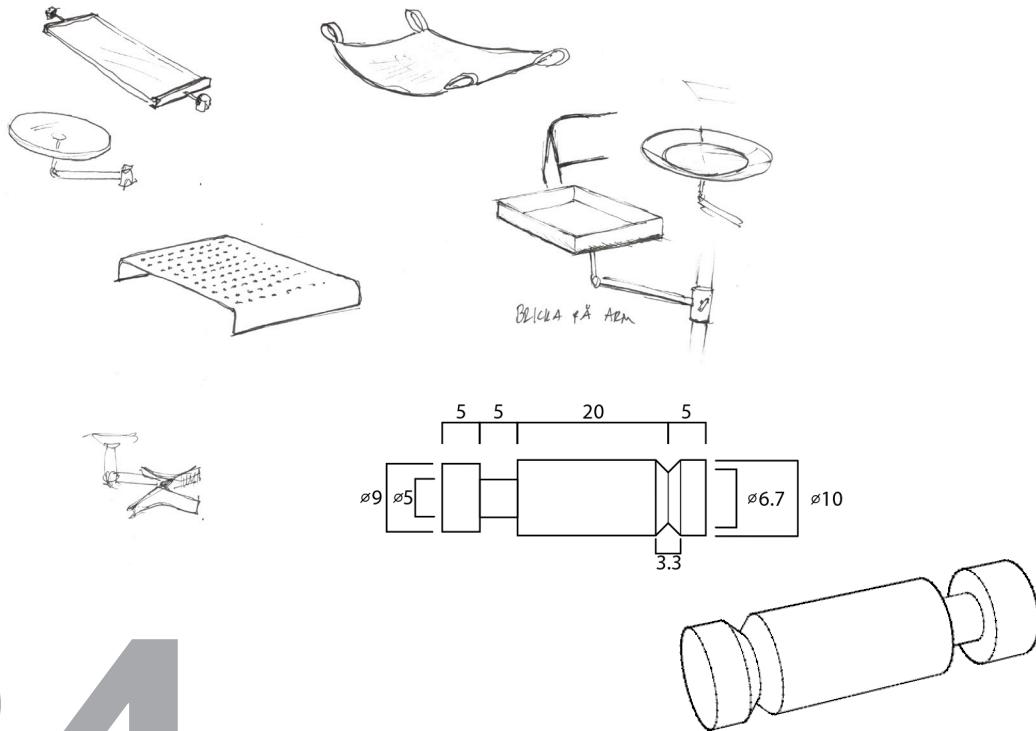

# Add-ons

In order to keep the similarity with the original valet stand I explored a variety of add-ons that could be featured on the frame. The add-ons would serve the purpose of the different features that the original valet stand has. For example there would be something that would give the user the opportunity to place its jewelry, watch, etc. One thing that all features needed to have in common was that they all fitted in the holes on the back on the front frame that allows the user to easily remove or

rearrange them. I designed several different types of add-ons where all served a different purpose. I tried having a mesh on the side in order to hang S-hooks of, many of these ideas were scrapped because they became too large and took too much of the focus away from the frame, as with the mesh. I focused on designing smaller add-ons that would disappear behind the frame. I came to the conclusion that the small hook would serve the best.

# Final product

The project resulted in a modern version of the valet stand which is wall mounted in order to be able to view the garment hung in it as a part of the interior of the home to make it more personal. The frame which the valet stand consists of is designed to respect the garment and give focus to it when placed in it. The frame is made out of solid oak which provides a beautiful color and texture with details of brass. The

details in the frame are made to make it look as seamless as possible. For example the corners which is cut into 45-45 degrees that gives beautiful corners from all angles. The valet stand is meant to hold one piece of clothing at the time but it is possible to hang more if the user wants to. The frame is open in the front bottom for longer garments to be hung in it with ease and not to interfere with the garment.





37





38





39



40







41

# Conclusion

With the process from a more complex piece of furniture to a simpler and cleaner one, it has been shown to me that with pure design one can emphasize an object's properties and value. Through my work, I have reached a product that is simpler and more resource efficient. For me, the project has meant a challenge to work with analysis and given me the opportunity to develop my knowledge and skills in furniture carpentry.

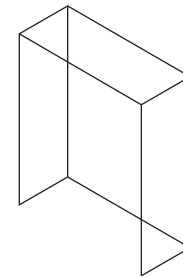
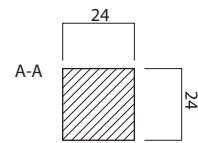
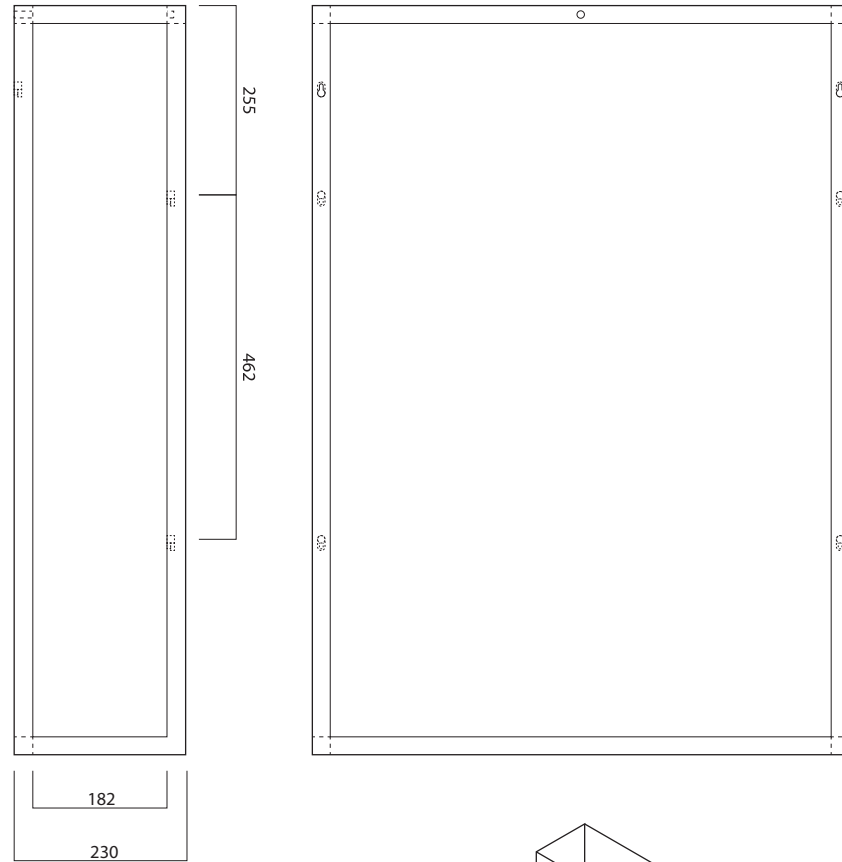
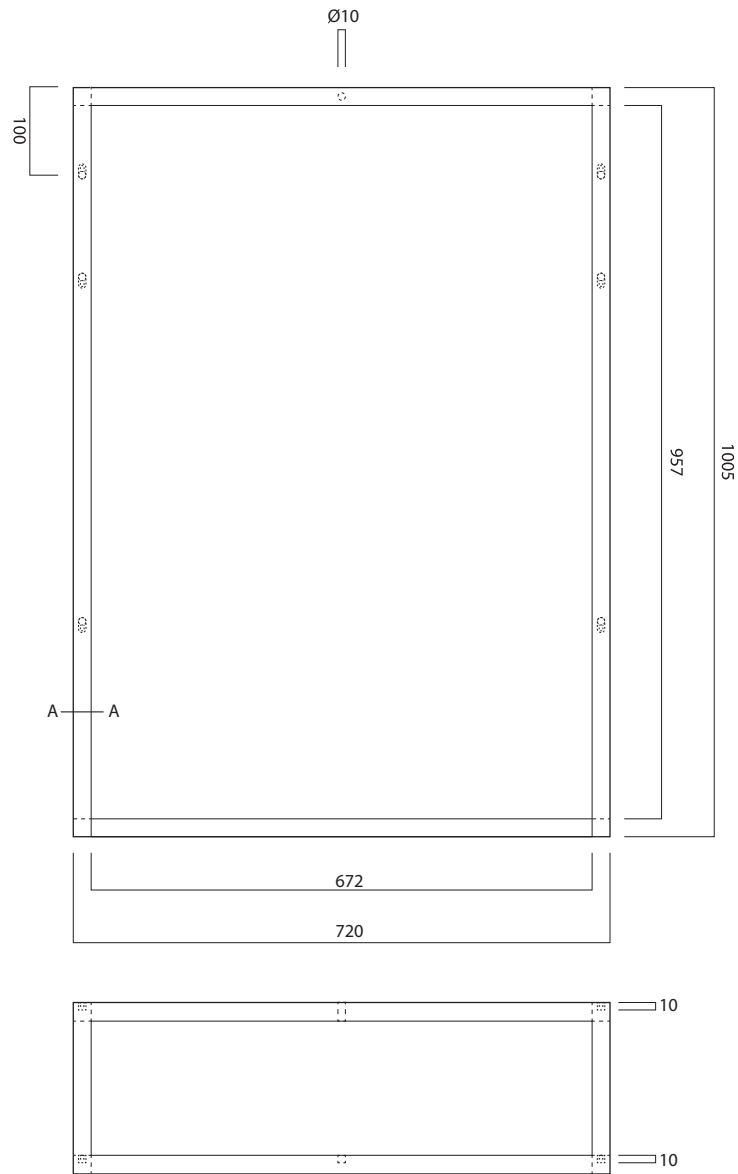

Dimensions in mm.

## References

1. IKEA Group. 2018. *Life at Home report 2018*. [https://lifeathome2018.ikea.com/wp-content/uploads/2018/09/LAHR18\\_Report\\_in\\_short.pdf](https://lifeathome2018.ikea.com/wp-content/uploads/2018/09/LAHR18_Report_in_short.pdf) (collected 2019-02-11)
2. Skoogh, Johan; student at Lund University. 2019. Conversation.

## Image references

1. Orngals, <https://www.instagram.com/orngals/> (collected 2019-06-26)
2. Mike Marquez, <https://unsplash.com/photos/A51OCdjUbxk> (collected 2019-04-05)
3. IKEA, <https://www.ikea.com/se/sv/p/turbo-klaedstaellning-inom-utomhus-svart-40177233/> (collected 2020-05-11)
4. Hildur Blad, <https://hildurblad.se/2013/12/diy-kladhangare-av-rundstav/> (collected 2020-05-22)
5. Pintrest, <https://www.pinterest.se/te11btomlunde/ba-project/> (collected 2019-04-26)
6. IKEA, <https://www.ikea.com/se/sv/p/ribba-ram-svart-50268874/>, edited (collected 2019-04-05)
7. Annie Spratt, <https://unsplash.com/photos/zqydEHovUkE> (collected 2019-04-25)
8. Desenio, <https://desenio.se/sv/monstera-one-poster>, edited (collected 2019-04-05)



**Thank You!**

