



**LUND**  
UNIVERSITY



# **ADAPTIVE SYSTEMS TO REDUCE THE MATERIAL COST OF STRUCTURES**

## **Parametric Design of Adaptive Trusses**

ERIK LUNDIN

Structural  
Mechanics

*Master's Dissertation*



DEPARTMENT OF CONSTRUCTION SCIENCES  
DIVISION OF STRUCTURAL MECHANICS

ISRN LUTVDG/TVSM--22/5261--SE (1-62) | ISSN 0281-6679

MASTER'S DISSERTATION

# ADAPTIVE SYSTEMS TO REDUCE THE MATERIAL COST OF STRUCTURES

## Parametric Design of Adaptive Trusses

ERIK LUNDIN

Supervisors: Professor **KENT PERSSON**, Division of Structural Mechanics, LTH  
and Dr **ALEXANDER SEHLSTRÖM**, WSP Sverige AB.

Examiner: Professor **ERIK SERRANO**, Division of Structural Mechanics, LTH.

Copyright © 2022 Division of Structural Mechanics,  
Faculty of Engineering LTH, Lund University, Sweden.

Printed by V-husets tryckeri LTH, Lund, Sweden, June 2022 *(Pl)*.

**For information, address:**

Division of Structural Mechanics,  
Faculty of Engineering LTH, Lund University, Box 118, SE-221 00 Lund, Sweden.

Homepage: [www.byggmek.lth.se](http://www.byggmek.lth.se)



# Abstract

Adaptive structures adapt to the changing circumstances in their environment using sensors and actuators, they may for example change their shape to be optimised for a specific load case when that load case is present. The building industry needs to reduce its climate impact, low-carbon solutions are in demand. Structures must be designed so that the design load does not cause failure, due to stresses exceeding the ultimate limit. They must also be designed so that the deflections in the serviceability limit state do not cause problems. To fulfil the requirements, a sufficient cross-section is normally chosen. Many structures are rarely exposed to the loads they are designed for, meaning the capacity is much larger than required for the vast majority of their life cycle. The material used causes emissions, the more material that is used, the larger the emissions. This thesis explores the opportunity to reduce the material cost of two-dimensional trusses by equipping them with an adaptive function. If the emissions caused by producing the energy required to activate the adaptive function, at the times large loads occur, is lower than the emissions of the material needed to fulfil the requirements without the function, emissions have been reduced. A program is created, capable of parametrically designing trusses to fulfil the serviceability limit state requirements of deflection by adaptively increasing the lengths of the struts. An analysis is performed with the program to compare alternative designs of adaptive trusses in different circumstances. The models generated in the analysis suggest that there is potential to reduce the amount of material with adaptivity. Adaptive trusses are compared to their non-adaptive counterparts, the material savings achieved range from 28 % to 89 %.



# Acknowledgements

Firstly, I would like to express my sincere gratitude for the guidance of my supervisor Alexander Sehltröm, PhD, whose advice and dedication has elevated my work to a higher level. It has been a pleasure to work with Alexander, and his mentoring has inspired beyond the limits of this thesis. I would also like to thank my supervisor prof. Kent Persson very much, especially for his vital support in understanding the most difficult theoretical areas of the thesis.

I am very grateful for the opportunity to write my thesis in collaboration with WSP. Thank you Andreas Gustafsson and Lucas Alsén for the chance to do this together. It has been a pleasure to get to know the entire structural engineering team at WSP in Malmö and I look forward to joining you this fall.

I would like to thank my examiner prof. Erik Serrano for his critique and continuous participation in the process which exceeded my expectations, thank you.

Many thanks to my opponent Calle Lind for his input on my work, for his camaraderie in writing our theses with WSP, and for being a good friend throughout these five years at Lund University.

I am delighted to have had the opportunity to go on exchange to Eindhoven University of Technology, and would like to say a special thanks to asst. prof. Arjan Habraken whose teaching in resource efficient structural engineering design inspired me to choose the subject of my thesis.

Finally, I would like to thank the whole organisation of Lund University and the faculty of engineering for my education and five wonderful years.





# Contents

<b>Abstract</b>	<b>I</b>
<b>Acknowledgements</b>	<b>III</b>
<b>Table of Contents</b>	<b>VI</b>
<b>1 Introduction</b>	<b>1</b>
1.1 Background . . . . .	1
1.2 Purpose . . . . .	3
1.3 Method . . . . .	3
1.3.1 Literature Review . . . . .	3
1.3.2 Design Concepts and Parametric Program . . . . .	3
1.3.3 Physical Model . . . . .	4
1.4 Scope and Limitations . . . . .	4
<b>2 Adaptive and Lightweight Structures</b>	<b>7</b>
2.1 Adaptive Structures . . . . .	7
2.2 The History of Lightweight Structures . . . . .	9
2.3 Material use and Energy Consumption in the Construction-Industry . .	14
2.4 Adaption to Prevent Exceeding Serviceability Limits . . . . .	17
2.5 Pre-Cambering and Pre-stress . . . . .	20
<b>3 Physical Model</b>	<b>23</b>
3.1 Material . . . . .	23
3.2 Method . . . . .	24
3.3 Results . . . . .	25
<b>4 Optimised Design, Design of Adaptive Structures, and the Finite Element Method</b>	<b>27</b>
4.1 Optimisation . . . . .	27
4.2 Design Strategy of Adaptive Structures . . . . .	29
4.2.1 Shape and Internal Load-Path Optimisation . . . . .	30
4.2.2 Actuator Layout Optimisation . . . . .	31
4.3 Finite Element Method . . . . .	31
4.3.1 Changing the Length of Elements . . . . .	33
4.3.2 Solving the Non-Linear System . . . . .	35
<b>5 The Parametric Design Program</b>	<b>39</b>
5.1 Conceptual Design . . . . .	39
5.1.1 Pratt Truss . . . . .	39

5.1.2	Truss with Crossing Diagonals and Without Bottom Chord . . .	40
5.1.3	Cable-Tensioned Beam . . . . .	40
5.2	The Program . . . . .	41
5.3	Inputs . . . . .	45
5.3.1	Material properties . . . . .	45
5.3.2	Geometry . . . . .	45
5.3.3	Loading . . . . .	45
5.3.4	Serviceability Limit State Maximum Deflection . . . . .	46
5.4	Outputs . . . . .	46
5.4.1	Program Performance . . . . .	46
5.4.2	Displacements and Activation . . . . .	47
5.4.3	Element Dimensions and Stresses . . . . .	47
5.4.4	Carbon Dioxide Emissions and Non-Adaptive Alternative . . . . .	47
<b>6</b>	<b>Using the Program</b>	<b>49</b>
6.1	Formulating the Optimisation . . . . .	49
6.2	Input Combinations . . . . .	49
6.2.1	Circumstances . . . . .	49
6.2.2	Design Alternatives . . . . .	50
6.3	Results . . . . .	51
6.3.1	CO <sub>2</sub> e Emissions . . . . .	51
6.3.2	Elongations . . . . .	52
6.3.3	Deflections . . . . .	53
6.3.4	Upwards Deflection in Unloaded State . . . . .	53
<b>7</b>	<b>Conclusion</b>	<b>55</b>
7.1	Challenges of Adaptive Structures . . . . .	55
7.2	Improvements of the Design Program . . . . .	56
7.3	Assessment of Results From Model and Analysis . . . . .	56
	<b>Bibliography</b>	<b>59</b>

# 1 Introduction

Adaptive structures have the ability to change their attributes depending on the circumstances. In nature, many examples can be found of organisms adapting to an ever-changing environment, trees shed their leaves in the winter to save energy, and they elastically deform when hit by strong winds. However, in the built environment, such adaptation is seldom utilised. Buildings are generally built to a set shape which they maintain, overlooking small displacements, no matter the circumstances. Optimising the shape of structures to best withstand design loads is an established task for structural engineers. The ability to enable a structure to adaptively change its shape to best fit the load case that is currently acting on it, provides the opportunity to save material and allows greater freedom in design. Lightweight structures are more prone to deform due to variable loads, which is the deformation that can be prevented with adaptation. Reducing the amount of material and adding adaptivity results in structures being more lightweight, leading to larger deflections should the adaptive function not be present.

This chapter presents the dilemma of buildings being required to withstand rarely occurring large loads, and not deform too much, in order to be safe. It proposes adaptivity as a means of reducing the material needed to fulfil design requirements. This proposal sets the foundation for the purpose of the thesis.

## 1.1 Background

Structures are static but the environment they are in is dynamic [1]. A structure is exposed to permanent and variable loads. The permanent load is composed of the self weight of members and other components of the building that are constant, such as surface materials. The variable load is composed of loads that differ over time. Wind load, snow load, and people walking on floors are examples of variable loads. Variable loads may differ in presence rate; load from furniture is almost constant while the load from a person walking across a floor is instantaneous. Currently, according to standards in Eurocode [2], structures are designed for a scenario in which the 50-year load of the main variable load and the 5-year value of other variable loads act simultaneously [3]. Such a scenario does not occur often. Achieving the load bearing capacity and the stiffness needed to comply with the standards requires material in terms of large cross-sections or more densely positioned members. An example of a characteristic load value used when designing a structure is  $2.0 \text{ kN/m}^2$  for a floor in a dwelling [4, p.7]. This roughly corresponds to the weight of three average Swedish people standing on every square metre of floor [5]. It is not unlikely that this happens occasionally, so it is important that the capacity is there, but it will most likely be on rare occasions.

Building materials used to achieve the required capacity causes an energy cost in

terms of excavating and producing the material and the members [6]. The energy cost is often related to emissions of carbon dioxide. Reducing the emissions of structures contributes to a more sustainable construction industry. The emissions of a building or structure should be analysed as a life cycle issue, in which all costs throughout the building's service life and beyond are measured. A way to reduce emissions of a building is to make it adaptive in different ways. A heating system for example, should be controlled to operate when the building is cold, if it would be operating at all times, it would waste a lot of energy. If the structural system is considered in a similar fashion, it can be deemed as rather wasteful that the structure always is capable of dealing with situations that are only expected to occur once every 50 years, regarding the energy cost of the material needed to achieve such capacity.

The dilemma of structures having to be designed for rarely occurring loads, leading to energy costs in terms of materials, might be solved by making the structures adaptive. Instead of using all the energy to produce structural members that are always able to withstand the design loads, material is saved in production and energy is used at the times it is needed through active adaption [6].

To determine the design of an adaptive structural system or member, it has to be designed with regards to a variety of load cases. A base geometry at the non-activated state has to be determined, it then has to be determined where actuators should be located, and how they should react when different loads are applied. The geometries that arise have to be controlled with regards to the load they are designed for. This causes a wide range of states and load cases that have to be checked and it would be virtually impossible to determine, check, and evaluate all possible designs of a system. Using a computational system can help to effectively design and control adaptive structures. Such a system has been developed by Reksowardojo et al. [7] for a planar truss with actuators that allow elements to alter their length. The method uses the information of external forces to determine target shapes and internal forces, different options for placement of actuators are compared to determine the most effective design.

When creating solutions to reduce the material consumption and make structures more resource efficient, it is important that safety is not compromised. Failures in structures leading to collapse of buildings can be devastating and put lives at risk, it must be prevented. Understanding how lightweight structures are designed to achieve safety is vital. Relying on adaptive functions to achieve the capacity required in the ultimate limit state is considered unsafe, since malfunctions in the adaptive system might lead to collapse [7]. Ensuring that the ultimate limit requirements are fulfilled without any actuation is preferred. However, relying on adaptive functions to fulfil the serviceability limit requirements does not impose the same risk, and may still provide significant material savings. An adaptive system may therefore be more suited to situations where the serviceability limit requirements are governing in design of structural members.

In summary; adapting a structure by supplying energy when it is needed has the potential of saving material compared to creating constant capacity by using more material. Designing such a system involves evaluating a vast amount of possible geometric optimisations and load cases, which calls for computational tools to aid in design. Using adaptive systems to prevent failure comes at greater risk than using it to comply with serviceability limit standards. If more elastic materials can be used because deflections

are prevented, there is more freedom of choice in terms of what materials to use.

## 1.2 Purpose

The purpose of the thesis is to:

- Increase the understanding of how resource-efficient structures can be constructed using adaptivity, and explore the material saving potential of adaptive systems by modelling adaptive trusses. As well as investigating the impact of the material choice has on carbon dioxide equivalent emissions.
- Create a parametric design program, and illustrate the benefit of it in structural design.

## 1.3 Method

The methodology of the thesis is a process consisting of three main steps that relate to the purpose; a literature review, development of design concepts, creation of a parametric program, and construction of a physical model.

### 1.3.1 Literature Review

A literature review focusing on lightweight structures, adaptivity, parametric design, optimisation, and the finite element method, was performed. History of lightweight structures is presented to show its development. Well-established methods such as pre-stressing and pre-cambering that relate to methods used in adaptive structures are explained. An existing method for designing adaptive trusses parametrically is studied and summarised.

The review explains what adaptive structures are, and how they fit the context of resource efficient structures, thus relating to the first purpose. It also provides knowledge needed to create a parametric design program.

### 1.3.2 Design Concepts and Parametric Program

Design concepts of two-dimensional, adaptive frame-based structures are developed. In this phase, alternatives for general geometries of structural systems are developed. It is determined where connections and elements are located in relation to each other.

A parametric computer program is developed to design adaptive trusses by allowing the struts to be axially elongated. The trusses are based on the design concepts developed in the earlier phase. The program illustrates the material saving potential

of adaptivity. Calfem in Python is used to perform finite element calculations needed in the parametric design program.

Analyses were made using the design program to compare how some of the different structures it can generate perform in different circumstances of span, load case and serviceability limit requirements. The results of the study aim to show both how different adaptive structures perform in terms of material consumption compared to each other, and how they compare to similar non-adaptive structures.

### 1.3.3 Physical Model

A physical model was built to demonstrate a simple two-dimensional frame based adaptive structure.

## 1.4 Scope and Limitations

The thesis is focused on exploring the opportunity to achieve material savings using adaptivity. It only regards the required element dimensions to comply with ultimate limit state and serviceability limit state requirements, connections between elements are not treated. It is also not regarded what the material and energy cost of implementing the adaptive function is. Further studies could aim at developing connections and an adaptive system consuming less energy than the energy saved by implementing it, resulting in a complete understanding of the material and emission savings achieved by the system.

Emphasis is put on understanding adaptive structures, and how they may contribute to reducing the material consumption in the building industry. Theory regarding optimisation is presented and how it can be used in parametric design of adaptive structures is explained. Optimisation is carried out to find the most efficient solution in terms of cross-sectional areas of elements. An automatic optimisation is not implemented to compare the different design concepts, however, it is discussed how this can be done.

The parametric design program is limited to two design concepts of two-dimensional trusses, a third concept is developed but not implemented in the program. The implemented concepts contain bar elements with axial forces only. Hence buckling of compressed members was not studied.

Sensor technology is a major topic in developing adaptive structures, but does not directly affect the material saving potential of adaptive structures. How it is implemented into the system controlling the adaptive structure has not been prioritised and is therefore not a topic of the report.

Aspects of an existing design method presented in [7], that was studied, was used as general guidance of how to build the design program. The theory used in the reference method was not implemented directly, the two methodologies are compared in the

conclusion.

The load that is applied in the design program is defined directly and not determined through a load combination that has been generated with the use of partial coefficients from design standards. This fits the purpose of determining the activation required to limit deflections, the system implemented to control an adaptive structure must work with numbers that represent the actual load being applied to the structure, and cannot rely on predetermined load combinations. It is also sufficient to illustrate the potential of adding adaptive struts in trusses.

The physical model is static without sensors and actuators. The load is applied and the actuation is performed manually.





# 2 Adaptive and Lightweight Structures

This chapter overviews adaptive and lightweight structures. Section 2.1 explains the basics of adaptive structures, and the possibilities they might bring. Section 2.2 is a review of the history of lightweight structures. It describes important advancements in technology that has contributed to the development of lightweight structures, as well as significant achievements made possible by lightweight structures. Section 2.3 relates carbon dioxide equivalent emissions to the choice of building material, to showcase its importance. Section 2.4 treats the goal of fulfilling serviceability limits that the design program is designed to achieve, using adaptivity. Section 2.5 explains a couple of well established methods of using internal stresses in order to improve the performance of structures.

## 2.1 Adaptive Structures

Adaptive structures is an idea proposing that buildings should be more dynamic in relation to their environment in order to be more efficient. Buildings are in many aspects static while the environment they are in is dynamic. An adaptive structural system is developed with the purpose of enabling the structure to be more efficiently configured for the current load at any given time. It is quite common that heating systems are adaptive to some extent, only being activated when the temperature in a building is lower than a certain threshold. Making components or systems in structures adaptive can be done using actuators or adaptive materials controlled by sensors [1]. Figure 2.1 illustrates the principle of adaptivity.

The adaptive system is capable of *sensing* stimulation which enables monitoring of the mechanical and thermal state, the data is mapped as a function of space and time. The system uses *actuation* to release stored or supplied energy (chemical, electrical or magnetic) into mechanical energy, in a structural system, this energy is used to control the shape of the structure or alter its stiffness. The information gathered by the sensors is processed by a *control strategy* which translates it to commands for the actuators [6]. There are different options to create an adaptive structure fit for different purposes. Teuffel [1] discusses adaptive geometry optimisation and adaptive materials further.

Geometry optimisation is a proven method to reduce the required material of structural systems. Optimising the geometry of a simply supported planar truss reduces the weight by 70 % compared to flat configuration of constant depth [7]. If the shape of a structure is adaptively optimised to the load that is currently applied to it, it can achieve the required capacity against that load at the time it is needed. It might be

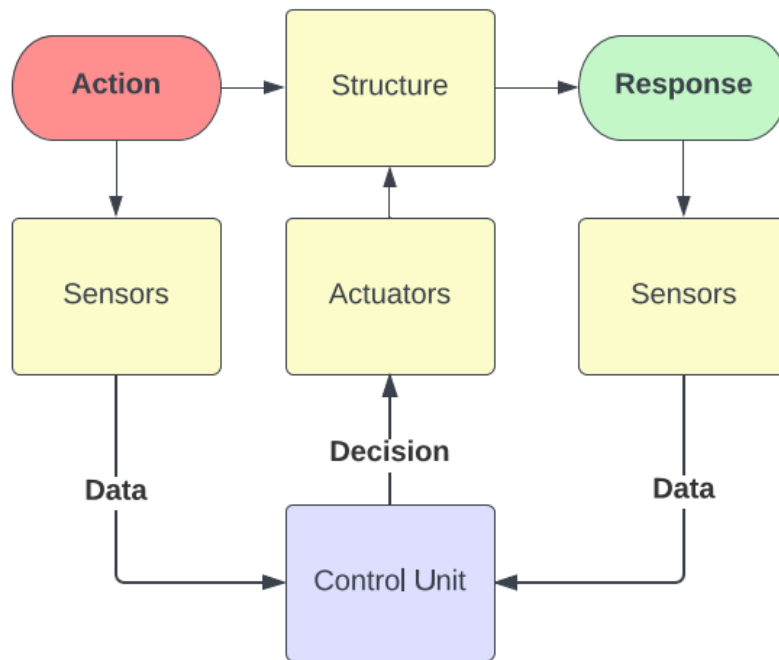

**Figure 2.1:** An adaptive structure uses sensors, actuators, and a control unit. The sensors register actions imposed on the structure. Imposed actions are registered by the sensors feeding data to the control unit, which after processing, commands the actuators to change state. The response of the structure is then measured by sensors and feedback data can be processed by the control unit to perfect the reaction of the actuators [1].

required that energy is supplied to the structure for it to be able to transform into the optimised shape.

The external load cases that a structure might be subjected to can be a starting point when determining how an adaptive system should be designed and how it should work. The system for designing an adaptive truss developed by Reksowardojo et al. [7] uses the external load cases as a governing factor. A structure that is occasionally subjected to large concentrated loads acting on different positions of the structure or in different directions can be designed to adapt its shape to best transfer the concentrated load. If the structure is subjected to varying volumes of distributed load it may adapt to higher volumes by adapting a shape that prevents the critical parts of the structure from displacing. The purpose of it can be to increase the performance or safety, the aim discussed by Reksowardojo et al. [7] is focusing on achieving energy savings. A structure is generally designed to be constantly capable of dealing with the worst imaginable load cases, meaning only a fraction of its capacity will be used at most times since buildings are designed after loads expected to occur once every 50 years [3].

The method developed by Reksowardojo et al. [7] aims to design a truss that needs less material by using adaptivity. The system is configured after a base load case, the permanent load. The actuation that transforms it to an activated state, demands energy. The energy efficiency performance of the structure is then analysed as a life

cycle issue; if the total energy cost of the actuation throughout the buildings lifespan is smaller than the cost of using additional material to satisfy the structural demands constantly, the adaptive system has saved energy. The energy cost analysis should include the costs of producing the adaptive system. Developing materials that cost less energy to produce, but can be enhanced by supplying energy to them during their service, would allow an adaptive system based on adaptive materials to save energy.

The potential efficiency based on energy consumption of implementing adaptive functions depends on the ratio between permanent and variable load. If the purpose of the structure is to carry mostly permanent load that can be determined beforehand, the gain is very small. If it is to carry a small permanent load and a large variable load, the adaptive function can enable large material savings. The presence of the variable load is crucial for the efficiency, the more frequent it is, the more energy has to be spent activating the system. The situation where it would be most effective is when the structure is mostly subjected to a certain load, but must be capable of handling much larger, rarely occurring loads. This situation is quite common in the built environment.

Because of doubts in the reliability of sensor and actuation technologies, the development of adaptive structures has mostly been limited to fulfil serviceability limit state criteria [6]. This does limit the applicability of adaptive structures, but it still provides a wide range of opportunities. In many situations, the design is governed by deflections in the serviceability limit state. Serviceability limits make it difficult to use materials that are highly flexible, they might not be close to failure, but they deflect too much.

Adaptivity is applied in structures today to control vibrations in buildings and bridges during exceptionally high loads. Hydraulic actuators have been tested as cross bracing to control the deflections. Deflection can be reduced in cable-stayed bridges if the stay-cables are active tendons. Active tendons can be used to alter prestress in concrete beams and steel trusses to reduce displacements under loading. Changing the position or angle of supports is another way to adapt a structure [6].

## 2.2 The History of Lightweight Structures

Lightweight structures are more prone to deflect by live load, and are generally more material efficient. Introducing adaptivity in lightweight structures may allow them to be used to larger extent. Since the dawn of human civilisation, lightweight structures have been applied using ropes, cloth, wood and iron chains. Examples of suspension bridges in the eastern Himalayas dating back to 285 BCE, can be found [8], Figure 2.2 shows a suspension bridge. Bridges are a natural application for lightweight structures since long spans have to be covered and a large self weight can be difficult to carry. The practical task of constructing a long span structure with heavy materials is difficult without the help of modern machinery. The Roman empire is known to have used cloths to create roofs in their amphitheatres. Cloth was hung in masts attached to the back of the stands, providing an effective solution to protect the spectators against sun light [9].



**Figure 2.2:** The Capilano suspension bridge near Vancouver, Canada.  
Photo: Björn Lundin.

The cloth roof is an early example of membrane structures, another example are tents used by nomads. Nomads require shelters that are easy to tear down, move and build up again in a new location. Light membrane structures fit the purpose well, the membrane is foldable and it can be supported by a light structure of struts and ties. Different examples of such nomad tents can be found across the world, the tipi was used by native Americans, the Bedouin tent (Figure 2.3) is from the middle east and north Africa, and yurts are from Mongolia. Tents have been used by many civilisations as temporary and moveable shelters, the combination of struts and ties to support a membrane is a common technique to make tents. Both the suspension bridges and cloth roofs can carry loads in tension but are unable to transfer loads through compression.

The development of cable structures accelerated when wrought iron with high tensile strength was developed during the industrial revolution in the United States and Europe. The development enabled larger suspension bridges to be built using chains. Pioneering engineers were Finley in the U.S.A, and Telford and Brunel in England [9]. Telford is known to have invented a chain system using flat eyebars with punched wholes. The eyebars experienced large strains at large tensile stresses, which lead to Telford determining that his chains should be designed so that the stresses never exceeded a third of the ultimate strength, this limit is similar to what is practiced in



**Figure 2.3:** A Bedouin tent.

Source: Photochrome Bedouins tent 1890-1900” by janwillemsen is licensed under CC BY-NC 2.0.

modern cable design [8]. The eyebar system dominated until flat wires were invented [8]. The first bridge using solid wires was designed by Sequin and Lame in France in 1829 [9]. The wires were cold formed, increasing the tensile strength. John August Roebling established a wire-manufacturing company in 1841 which went on to produce wires for the famous Brooklyn Bridge in New York City [8].

Severe collapses of suspension bridges have occurred. In 1940, the Tacoma bridge collapsed in Ohio just four months after its opening. The collapse was caused by heavy wind on the bridge leading to resonance. The bridge was designed based on elastic distribution theory by Moisseff and Lienhard, using a system in which the main cables were stiffened through the suspenders in order to reduce the wind load absorbed by the deck. This resulted in two and a half metre deep girders being used instead of almost eight metre deep trusses along the edges of the deck. Wind can pass through a truss between the chords, while it has to pass under or over a girder, causing the deck to sway up and down. The bridge was only built for two road lanes, it was just twelve metres wide. The combination of smaller stiffness in the bridge deck and the inability of wind to pass through the girders made the bridge vulnerable to wind. There is famous video-footage available showing the resonance and collapse of the bridge [10].

Around the year 1900, another kind of structure using cables started developing. Russian architect Vladimir Shukhov designed the first structure using cable nets for the Nizhny Novgorod exhibition in 1895. His work inspired generations of architects and engineers. ”Olympiastadion” in Munich (Figure 2.4) is perhaps one of the most iconic and influential structures in modern times. It was built for the Olympics in 1972 and was designed by German architect Frei Otto, one of the most recognised names in the field of lightweight structures together with Shukhov. The Olympic stadium was designed together with engineer Jürg Schlaich, whose engineering firm went on to become one of today’s leaders in the field of lightweight and cable structures [8].

Cables have the ability to transfer stresses in tension but cannot provide any stability in compression. A suspended structure is put in tension by gravity and will naturally find



**Figure 2.4:** "Olympiastadion" in Munich.  
 Source: Olympic Stadium, Munich" by wodka\_lemon is licensed under CC BY 2.0.

a shape were it is stable unless a large force pushes it in another direction. Prestressing the cables can be done to create cable structures in shapes that are not dependent on gravity with high stability and capacity.

Prestressing a structure means putting it in a self-equilibrated state of stress prior to it being put in service. It can, for example, be very useful when elements only may transfer stress in either compression or tension [11]. Prestressed cables are put into a system in tension, if a force acts on the system so that the reactions at the connection points of the cable changes in a direction that would put the cable out of tension, the tensile stress is reduced and the shape of the cable is maintained without sagging. The cable only deforms in axial strain determined by the Young's modulus of the cable. This can reduce the deformations caused by external forces in many structural systems. Figure 2.5 displays the displacement of a frame with non-prestressed cable cross bracing, and a frame with prestressed cable cross bracing being subjected to a horizontal force. In the non-prestressed frame, the cable that is elongated has to resist the entire horizontal force while both cables can contribute in the prestressed frame.

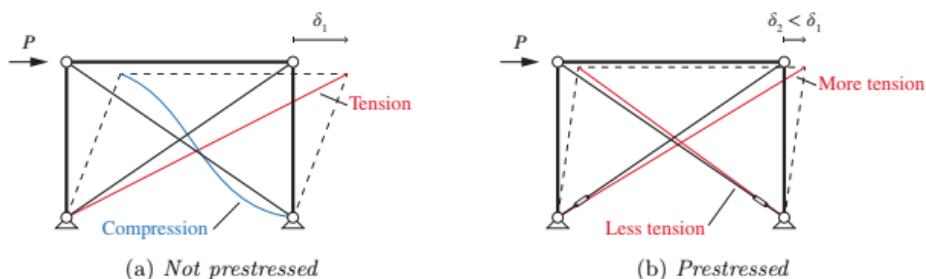

**Figure 2.5:** Two cable-braced pin-jointed frames loaded with a horizontal load  $P$  causing the top node deflection. Both are equal except that structure (a) is not pre-stressed, whereas (b) is. Sehlström [12].

Prestressing in structures date as far back as 3500 years ago when Egyptians used it to prevent boat hulls from curving. George Ferris used prestress to create the original Ferris wheel for the World's Columbian Exposition in Chicago in 1893. Between 1860 and 1880 the Pratt- and Howe-trusses were developed in the U.S.A. The Wright brothers built their planes as three-dimensional Pratt-trusses, the wings were the upper and lower chords, with vertical timber struts and prestressed tension wires as cross bracing between them. [11]. Figure 2.6 shows the Wright Flyer, the aircraft completed the first flight with an airplane ever on december 17th 1903 in North Carolina.

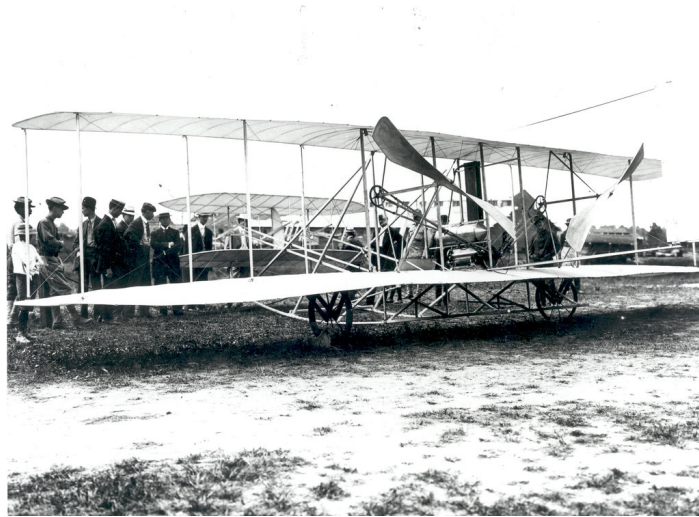

**Figure 2.6:** The "Wright Flyer" being demonstrated in Fort Myers.  
Source: "Wright Flyer demonstrations at Fort Myer" by amphalon is licensed under CC BY-NC-SA 2.0.

## 2.3 Material use and Energy Consumption in the Construction-Industry

The Paris Agreement adopted by 196 parties states that the global warming is to be kept below two degrees Celsius, preferably one and a half degrees, compared to pre-industrial levels [13]. To achieve the goal, the emissions of greenhouse gasses causing rises in temperature have to be reduced to the extent that the net-surplus of such gasses in the atmosphere is zero [13]. Carbon dioxide ( $\text{CO}_2$ ) emissions occur in relation to many human activities, it is, for example, produced when organic materials are combusted and is a by-product in the chemical reaction used to produce Portland cement [14, p.250]. In 2014 the annual greenhouse gas emissions from construction processes were almost equal to the emissions caused by all cars in Sweden, and exceeds the emissions from buses and trucks. Of the emissions caused by construction processes, 84 % can be traced back to building materials [15]. If emissions from building materials are reduced, it would have significant impact on the total emissions of greenhouse gasses. Boverket, the Swedish National Board of Housing, Building and Planning, provides a data base with information about the climate impact of different building materials [16], it is stated how much  $\text{CO}_2$  equivalent ( $\text{CO}_2\text{e}$ ) is emitted per kg of material. This data can help in making decisions that result in lower emissions from construction processes.

Choosing materials with less climate impact in relation to their strength is advantageous when designing structures with high capacity and low emissions. By comparing the  $\text{CO}_2\text{e}$  emissions per kg of material to the specific strength of different building materials the amount of  $\text{CO}_2\text{e}$  emissions in relation to the stress capacity is determined. This essentially tells us how much greenhouse gas that is being generated for every pascal of material strength. Table 2.1 shows the  $\text{CO}_2\text{e}$  emissions divided by the specific strength of common building materials. The materials have been compared with regards to tensile and compression strength, parallel to the grain for timber. Observe that these values can not be considered as a final determinant of which material is the most climate efficient in every situation, they are a first indicator that the capacity obtained with regards to climate impact can differ depending on the choice of material.

Values of  $\text{CO}_2\text{e}$  emission per kg and densities are taken from Boverkets data base for climate declaration 2022 [16]. The yield strengths of the materials are taken from Isaksson and Mårtensson [4]. The emission values of concrete are available for each strength class while the values for timber, glued timber and steel are defined for sawn timber, glued timber and construction steel respectively, meaning one value has to represent a variety of strength classes. Common strength classes of sawn timber and glue-lam are chosen to represent them in the comparison and two common strength classes of steel are considered.

Table 2.1 shows that sawn timber causes the lowest emissions with regards to both tensile and compression strength, followed by glued timber. Consider as well that the bending strength of timber is higher than the axial strength [4, p.118], the performance with regards to bending strength would be even better. As expected, the emissions of concrete is high with regards to tensile strength and significantly lower with regards to compression strength. The emissions of steel per Pa of compressive strength are 54



**Table 2.1:** CO<sub>2</sub>e emissions  $\beta$  of building materials in relation to their yield strength  $f$ ,  $\rho$  is the density of the material, ( $t/c$ ) represents (*tension/compression*). Structural properties of materials are from [4], densities and specific CO<sub>2</sub>e emissions are from [16].

Material	$f$ [MPa] $t/c$	$\rho$ [kg/m <sup>3</sup> ]	$f/\rho$ [kPa m <sup>3</sup> /kg] $t/c$	$\beta$ [kgCO <sub>2</sub> e/kg]	$\beta\rho/f$ [kgCO <sub>2</sub> e/(MPa m <sup>3</sup> )] $t/c$
<b>C25/30</b>	2.6/25	2350	1.1/10.6	0.137	124/12.9
<b>C25/30 impr.</b>	2.6/25	2350	1.1/10.6	0.103	93.3/9.70
<b>C30/37</b>	2.9/30	2350	1.2/12.8	0.153	124/12.0
<b>Timber GL30c</b>	19.5/24.5	434	44.9/56.5	0.175	3.90/3.11
<b>Timber C30</b>	18/23	455	39.6/50.6	0.105	2.66/2.09
<b>Steel S235</b>	235/235	7850	29.9/29.9	3.391	113/113
<b>Steel S355</b>	355/355	7850	45.2/45.2	3.391	75.0/75.0

times the corresponding emissions of sawn timber.

The total strength needed in a structural member is determined by a combination of the self weight and other loads acting on the structure. Just comparing how much CO<sub>2</sub>e is emitted to achieve a bearing capacity of a certain volume is therefore not relevant. It must also be considered how much self weight is required to carry the total load. Take the example of determining the CO<sub>2</sub>e emissions, bearing capacity and self weight of a circular element of C25/30 concrete, Timber C30 and Steel S355 being subjected to axial compression only. Suppose that the geometry of the loaded material is a three metre long cylinder with the surface area of 0.05 square metres. Table 2.2 compares the compression capacities and stress caused by self weight of the cylindrical elements to determine the capacity to carry additional weight and how much CO<sub>2</sub>e is emitted per kg of additional weight capacity. In the comparison, the sawn timber requires the least emissions for every kg it can be loaded with. The concrete requires 6.3 times as much emissions and the steel requires 35 times the amount of the timber.

**Table 2.2:** CO<sub>2</sub>e emissions of axially compressed elements. Structural properties of materials are from [4], densities and specific CO<sub>2</sub>e emissions are from [16].

Material	Mass [kg]	$\sigma_{sw}$ [MPa]	Strength [kN]	Imposed Capacity [kg]	CO <sub>2</sub> e/kg( <i>capacity</i> ) [kg]
<b>C25/30</b>	353	0.0705	1250	5898	0.0082
<b>Timber C30</b>	68	0.0137	1150	5682	0.0013
<b>Steel S355</b>	1178	0.2355	1775	87570	0.0456

**Table 2.3:** CO<sub>2</sub>e emissions of loaded beam. Structural properties of materials are from [4], densities and specific CO<sub>2</sub>e emissions are from [16].

Beam	Span	Mass	Strength	Imposed Load Capacity	CO <sub>2</sub> e/ $q_{imposed}$
	[m]	[kg]	[MPa]	[kN/m]	[kg/(kN/m)]
<b>C30 70x220</b>	6	42.0	30	1.16	1.36
<b>S355 HEA220</b>	6	303	355	40.1	25.6

A similar comparison determining how much emissions are produced per capacity of kN/m of linear load on a beam spanning 6 metres is performed. The comparison is made regarding to ultimate capacity with respect to bending. An HEA220 made of S355 and a 28 × 220 C30 timber are compared. Table 2.3 displays the results of the comparison. The steel beam causes 18.9 times the amount of emissions for every kN/m of imposed load compared to the timber beam, but has a much larger capacity.

The deflection in the serviceability limit state can be the governing factor for the design of a structural member. The CO<sub>2</sub>e emission were determined in relation to the linear load which causes a deflection of L/300 for the same beams as in the previous example with the span of 6 metres, with the span of 4 metres and a larger timber section spanning 6 metres. Table 2.4 shows the CO<sub>2</sub>e emissions per kN of imposed load capacity on the simply supported beams made of steel S355 and timber C30. The timber is assumed to be in climate class 1.

**Table 2.4:** CO<sub>2</sub>e emissions in relation to load capacity with regards to [4], densities and specific CO<sub>2</sub>e emissions from [16].

Beam	Span	Mass	Allowed Deflection	Imposed Load Capacity	CO <sub>2</sub> e/ $q_{imp.}$
	[m]	[kg]	[mm]	[kN/m]	[kg/(kN/m)]
<b>C30 28x195</b>	6	14.9	20	0.129	12.2
<b>C30 28x195</b>	4	9.94	13.3	0.494	2.11
<b>C30 70x220</b>	6	42.0	20	0.538	8.23
<b>S355 HEA220</b>	6	303	20	13.0	79.3
<b>S355 HEA220</b>	4	202	13.3	44.9	15.2

In Table 2.4 the longer span of 6 metres requires significantly more CO<sub>2</sub>e emissions per kN/m of imposed load than the shorter span of 4 metres, both for steel and timber. This is expected since the deflection is linearly dependent on the length of the span to the power of 4. Using a larger timber profile reduces the CO<sub>2</sub>e emissions with respect to the imposed load capacity. The CO<sub>2</sub>e emissions of the steel is higher than that of timber. The steel beams have a much larger capacity of imposed load than the timber beams, this means that there are situations where it would be difficult to use a timber beam rather than a steel beam, even though the CO<sub>2</sub>e cost of steel is larger with respect to the load capacity. If the capacities with regards to deflection are compared to the capacities with regards to ultimate strength checked in the previous example, the capacities with regards to deflection are significantly lower.

Determining that one material has the smallest climate impact in relation to its structural capabilities in every situation is perhaps not possible. In some situations, a certain material has to be used for practical reasons or because it is the only material that can provide the capacity and stability needed. A beam has to be designed with respect to more issues than bending and serviceability deflection. However, it is always possible to compare two working solutions in terms of their climate impact. Taking emissions into account when designing a structure and choosing what materials to use, can reduce the total climate impact of the building project significantly.

The ultimate limit capacity is related to the strength of the material while the serviceability limit behaviour is depending on Young's modulus. This means that if a material has a large strength compared to its Young's modulus, it will be difficult to take advantage of that material's strength in construction since members made of it will exceed serviceability limits at much smaller loads than their ultimate limit. This is a common issue with materials such as timber or high strength steel, which can have a much higher strength than normal steel, but has the same Young's modulus.

## 2.4 Adaption to Prevent Exceeding Serviceability Limits

A structure is designed with regards to the serviceability limit state to ensure that it will perform well during its service life. Meaning that the design should be carried out to ensure that deflections and displacements do not influence its ability to fulfil its purpose negatively, or damage other components of the structure. The design should not allow unpleasant oscillation. Cracking of the structure should be limited since it may have an affect on the building's function and safety [3, p.437].

When determining what load a member should be designed for, the characteristic value of the load is used and manipulated with the use of combination factors and partial coefficients. The characteristic value of a variable load is defined as the value that occurs once every 50 years. Combination factors are used to find the combination value (5 year load), the frequent value (present 1 % of the time) and the quasi permanent value [3, p. 43]. For the serviceability limit state, SS-EN 1991 Eurocode 1 [2] states load combinations in which the permanent load is combined with the main variable

load's characteristic value and other variable load's combination value [4, p.4]. The guidelines for designing with respect to deformations in the serviceability limit state vary depending on material, type of member, situation among other factors. Figure 2.7 displays the variable actions over time.

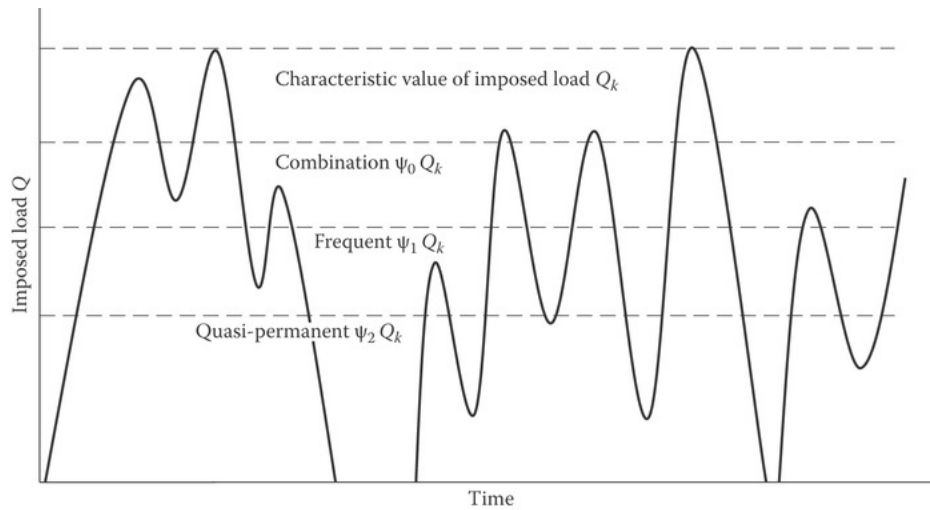

**Figure 2.7:** The variable actions over time. Elliot [17].

Design with regards to deflections is often carried out in the sense of limiting it to a certain level. The purpose is to ensure that the structure is safe and that the deflections do not cause problems with its functionality. Large deflections can cause problems with for example water runoff, uneven surfaces to place equipment or furniture on, doors being unable to open and close among other issues. Different countries treat the deflection limits differently, in Sweden, there are guidelines stating a limit of maximum deflection based on the length for different kinds of structural members, these guidelines are not to be treated as regulations, every situation is judged independently to ensure that the structure will function as intended [3, p.439.]

Deflections of a structure are highly dependent on the shape of the structure with respect to the direction of the loading. Taking the example of bending a piece of sawn timber in its stiff direction compared to its weak direction quickly proves that. The deflection of a simply supported beam being subjected to linear load or a point load is inversely dependent on the moment of inertia which in turn is linearly dependent on the height of the cross-section to the power of three [4]. A taller cross-section will have smaller deflections. The use of creating an adaptive beam with a solid cross-section that changes its height in order to reduce deflections will however be quite limited, the material enabling it to be taller still has to be there, it might as well be taller all the time.

Figures 2.8-2.10 illustrate the impact of variable loads on differently configured beams. Figure 2.8 shows a passive beam that is optimised for permanent load only and a passive beam that is optimised for permanent and variable load, the variable load requires an increase in material to decrease the deflection. Figure 2.9 shows how a prestressed beam designed to have a deflection of zero when only permanent load is applied has a deflection when variable load is acting as well, it then shows that a cable-tensioned beam that is designed to not deflect when variable load is applied will

deflect upwards when it is not applied. Figure 2.10 compares a passive cable-tensioned beam to an adaptive one, when variable load is applied to the adaptive system, the strut is elongated and the deflection is prevented.

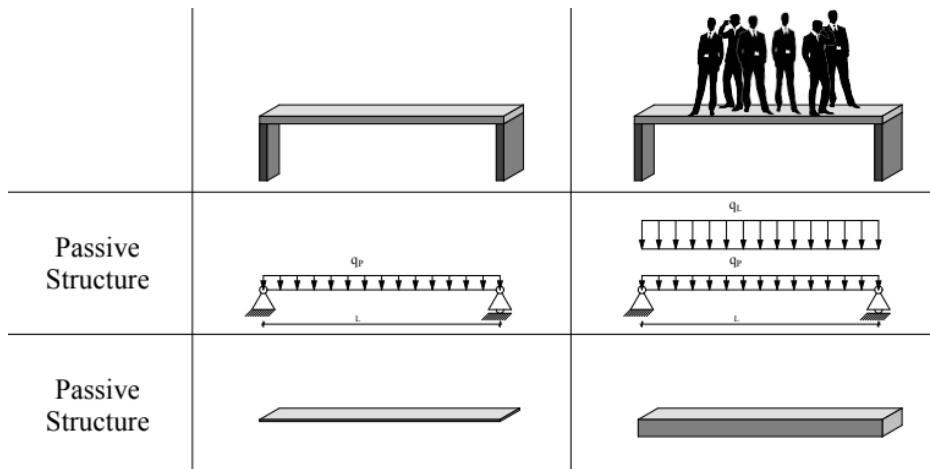

**Figure 2.8:** Load on passive structure, Rooyackers [18].

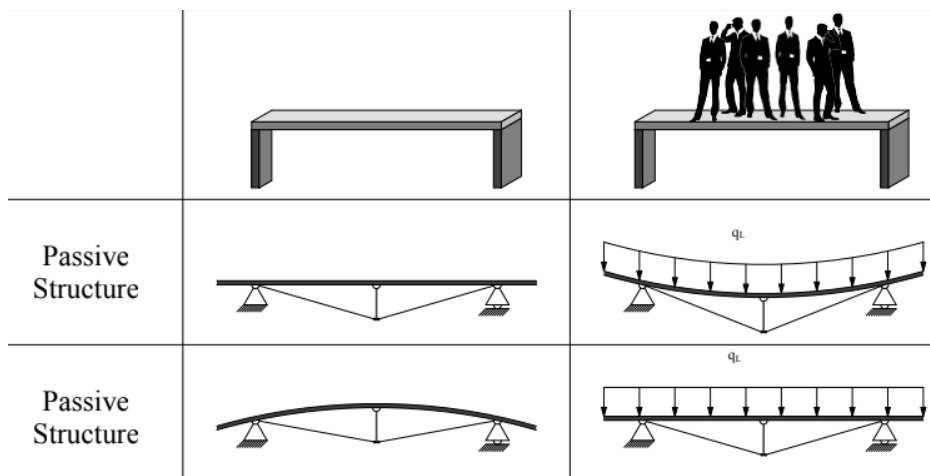

**Figure 2.9:** Deflection of passive structure, Rooyackers [18].

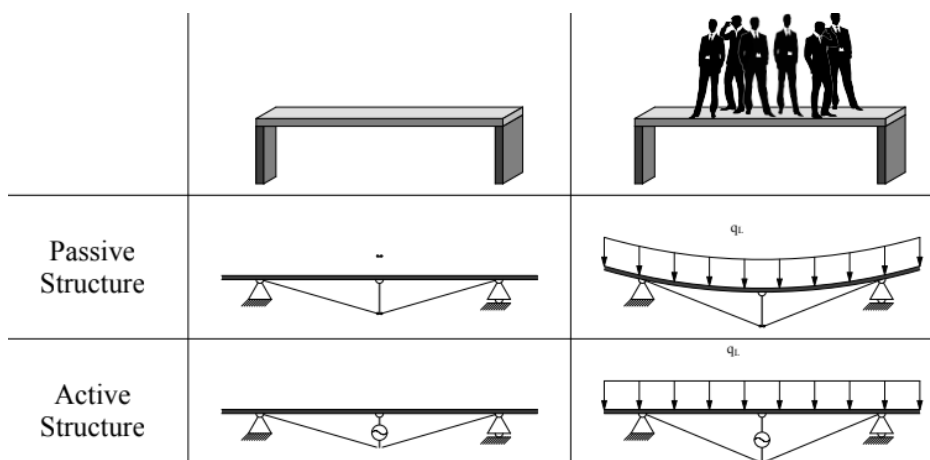

**Figure 2.10:** Deflection of passive vs. adaptive structures, Rooyackers [18].

An adaptive system enables the serviceability limit requirement to be fulfilled, using less material than a static solution but still providing sufficient capacity. When a structure is under loading that causes it to deflect too much, there is the possibility to make an adjustment of the geometry that enables internal forces to counteract the deflection caused by the external load, preventing the structure from deflecting. If the variable load is not present and the change of geometry is maintained, the structure would deflect in the opposite direction. Through adaptivity, the geometry change can be introduced when it is needed, and deflection is prevented in both direction.

Design in the serviceability limit state can be more difficult to carry out accurately than design in the ultimate limit state. This is mainly due to uncertainties in the material's behaviour, effects of time, and climate may cause unpredictable effects [3]. These uncertainties provide an additional benefit of adaptivity, the ability to measure and adapt to the structures behaviour over time means that the structure may be kept effective over its life cycle.

## 2.5 Pre-Cambering and Pre-stress

Pre-cambering and pre-stressing are methods to improve the performance of structures and are used in several applications. Attaching a tension cable underneath a beam with struts from the cable to the beam introduces stress in the system, reducing the deflection. Figure 2.11 shows an example of such a system Träguiden [19]. If the struts are actuators and can be elongated or shortened depending on the load acting on the system, the tension in the system could be controlled to reduce the deflections adaptively.



**Figure 2.11:** Cable-tensioned beam system. Träguiden [19].

Pre-cambering- *pre-camber*, 'camber' means bent in old French, is a technique where an initial deflection is introduced before or during the construction to counteract the deflection caused by self-weight and loads on the member during the life of the structure. For steel beams, pre-cambering is either achieved through mechanical bending or by heat-treatment bending whereby one side is elongated more than the other [20]. Introducing an initial bending that is then counteracted by permanent or variable loads reduces the distance between the position of the beam in service and the desirable position. Pre-cambering in combination with pre-stressing can also improve the

ultimate bending capacity. When installed, there is tension in the top of the beam and compression in the bottom. Loading will then first reduce the cambering before it starts causing bending in the other direction, leading to more load being able to be applied before the ultimate limit is reached in that direction. The pre-cambering is limited by serviceability requirements preventing it from bending the element too much in the direction it is being cambered in. Adaptively inducing more cambering that counteracts bending caused by load would enable this limit to be circumvented.

Cable-tensioned beams are similar to a truss with a top chord in compression, a bottom cable in tension and compression struts in between. They can for example be an effective solution when it is desired to use timber but a large structural height is needed to limit the deflection since timber has a fairly low Young's modulus. The top chord can be made of timber which has large compression strength. The top chord and the struts requires sufficient stiffness in all directions since elements in compression are at risk of buckling. The tension cable can be very slender since elements in tension will not buckle. The cable is connected directly to the top chord, balancing its reaction force by compressing the chord, this means that no horizontal forces need to be transferred in the supports, if the beam is simply supported [19].

The relation between the stiffnesses in the system of a cable-tensioned beam impacts how the system works. If the beam is soft, the cable is in large tension and the struts are stiff, the beam can be considered continuous over several supports. If the beam is very stiff and the tension in the cable is low, the beam will also be subjected to the tensile stresses and it will be exposed to conventional bending [19].

Special care must be taken when designing cable-tensioned beams due to stability reasons. The roof of Tarfalahallen in Kiruna (Sweden), supported by cable-tensioned beams, collapsed on the 7th of march 2020 [21]. If the connection between the struts and the beam is a hinge, it should be placed above the end connection between the beam and the truss. If it is not, there is a risk that the cable and struts are pushed out of plane when the beam is subjected to load from above. Figure ?? shows three different configurations, and the positions of the hinges where the struts and the cables connect to the beam.

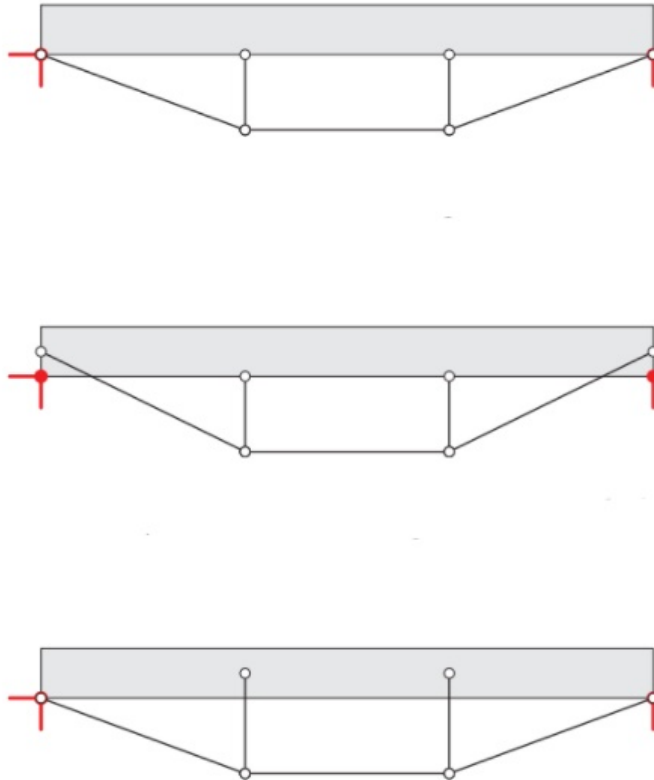

**Figure 2.12:** Three different configurations of cable tensioned beams, note the positions of the nodes in relation to each other. The two examples above are unstable while the lower example is stable. Sehlström [21].



# 3 Physical Model

A physical model was built to illustrate the principle of adaptive two dimensional simply supported horizontal structures. The model has manually controlled actuators that allow the struts to be elongated. Load was applied to the beam in the shape of weights and the struts are elongated to reduce the deflection of the top chord below a certain limit. Note that no optimisation has been carried out when choosing the material for the model, focus is just on illustrating an adaptive structure.

## 3.1 Material

The material used to build the model is displayed in Figure 3.1.

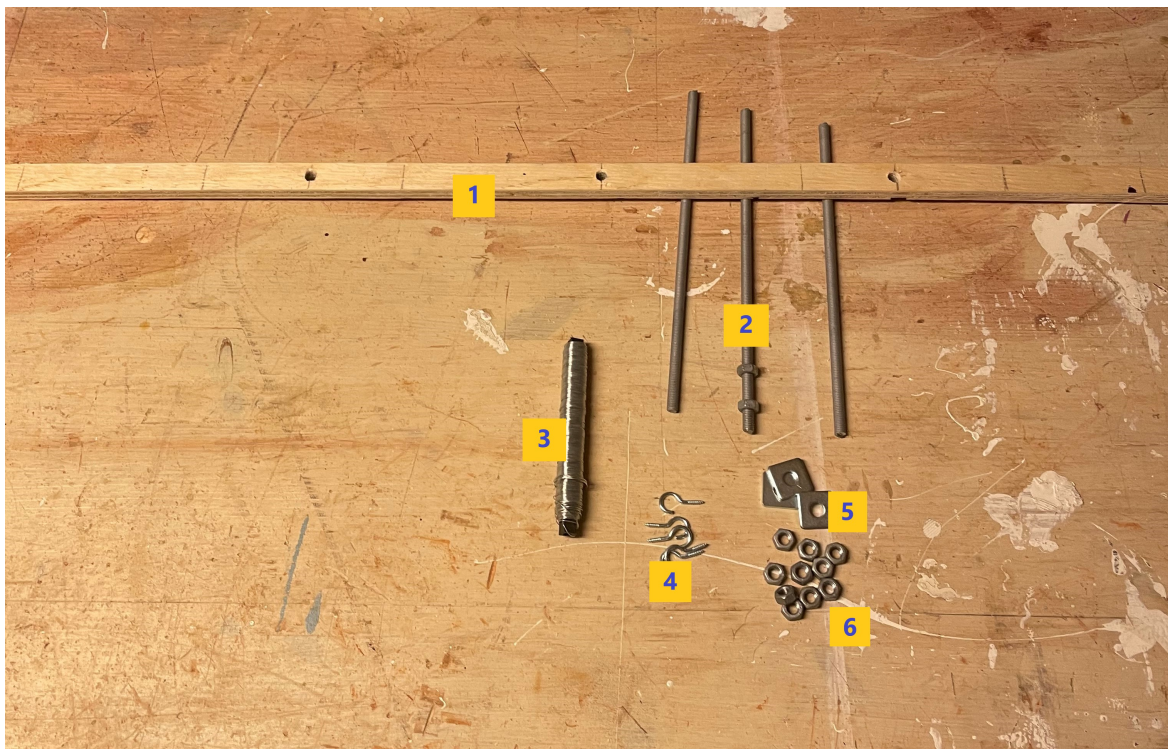

**Figure 3.1:** Materials used to build the physical model.

The highlighted objects in Figure 3.1 are:

1. 1000 mm long plywood joist with  $b \times h = 20 \times 15$  mm.
2. Three 250 mm long M8 threaded rods.
3. Steel wire.

4. Two steel hook hangers.
5. Three steel washers.
6. Twelve M8 nuts.

Tools and other material that were used to build the model and test it was a drill, a hacksaw and a wrench, tape, a weight, a whiteboard, and two magnetic whiteboard erasers.

## 3.2 Method

Figure 3.2 displays the finished model.

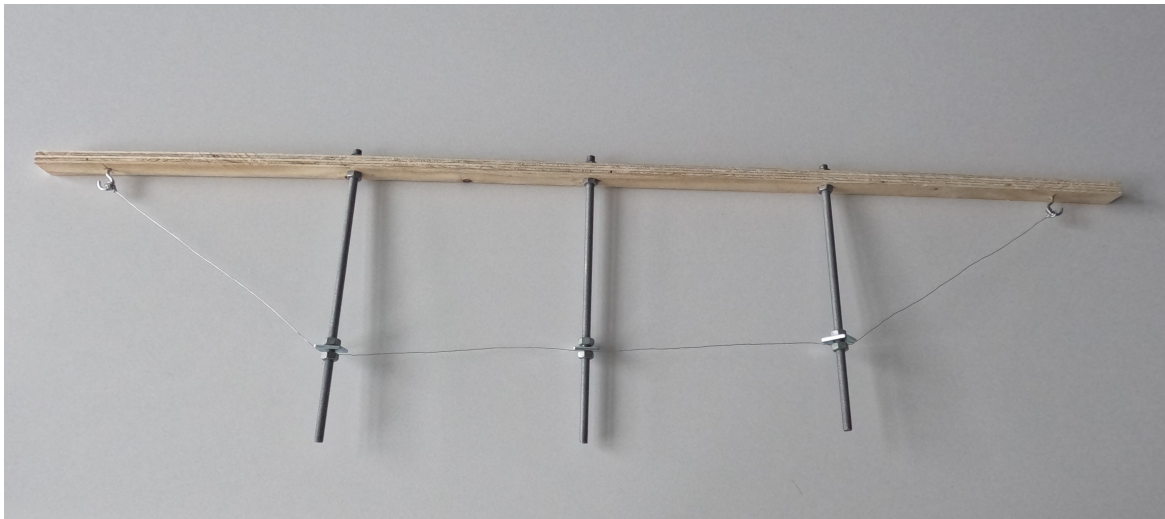

**Figure 3.2:** The physical model.

The model was built according to the following steps:

1. Three holes were drilled along the centre line of the long direction of the plywood joist, the holes are visible in Figure 3.1. Starting from one end, the holes are positioned at 275 mm, 500 mm and 725 mm.
2. The rods were threaded through the drilled holes and fastened to the joist with nuts on both sides.
3. The hook hangers were attached to the bottom of the joist. Starting from one end, the hooks are positioned at 60 and 940 mm.
4. Nuts and washers were threaded to the rods and positioned 100 mm from the bottom of the joist.
5. Wire was attached to the hooks and the washers.

The truss was placed on two tables acting as supports at its ends and taped to the tables, each support is 50 mm long. It was positioned in front of a whiteboard and the magnetic erasers are placed as references behind it. The truss was then loaded with the weight and the lengths of the struts were adjusted to counter the deflection caused by the weight.

### 3.3 Results

Figures 3.3-3.7 displays the model in different situations. Note the differences in shape and deflection. Observe that the differences are small.



**Figure 3.3:** The model when it is inactivated and unloaded.



**Figure 3.4:** The model when it is inactivated and loaded.



**Figure 3.5:** The model when it is slightly activated and loaded.



**Figure 3.6:** The model when it is activated and loaded.



**Figure 3.7:** The model when it is activated and unloaded.

# 4 Optimised Design, Design of Adaptive Structures, and the Finite Element Method

Optimised design can be applied in structural engineering to find the most material-efficient structures that fulfil the requirements with regards to structural integrity. Design of adaptive structures involves determining a solution that is effective with regards to several situations at once, why finding the optimal one often proves to be complicated. Section 4.1 introduces the principle of optimisation as a method to find the most efficient solutions of problems. A design methodology in which optimisation is used to find the most efficient design of an adaptive truss is presented in [7], a summary of the method is explained in section 4.2. In section 4.3, the finite element theory of non-linear bars that is used in the design program is presented.

## 4.1 Optimisation

Optimisation of structural models is a powerful method to evaluate design alternatives early to find efficient forms [22]. It can also be applied in late stages to select the most efficient cross-sections and materials. Structural optimisation is a proven method to reduce the required material of structural systems. Optimising the geometry of a simply supported planar truss reduces the weight by 70 % compared to flat configuration of constant depth [7, p.2]. The considerations for the structural optimisation differ in passive and adaptive structural systems. In passive systems, the geometry optimisation has to be configured in such a way that one geometry fits different load cases. Adapting the geometry to the load case enables the structure to be optimised specifically for each load case at the time the load case is present [6].

To describe a problem of structural optimisation, an objective function  $\xi$  is defined. The objective function represents a sought after attribute of the structure such as its stiffness or volume. Depending on the nature of the attribute, the objective function is either maximised or minimised in the optimisation. The objective function depends on a design parameter  $x$ , describing the design of the structure.  $x$  may, for example, describe the cross-sectional area of each bar in a truss. The objective function may also depend on additional state variables  $y(x)$  representing the structural response given design  $x$ , for example, stresses, displacements, or strains. Subjecting the objective to constraints of the design and response gives the following:

$$\left\{ \begin{array}{l} \min_x \quad \xi(x, y(x)) \\ \text{subject to} \quad \left\{ \begin{array}{l} \text{constraint of } x \\ \text{constraint of } y \\ \text{equilibrium constraint} \end{array} \right. \end{array} \right. . \quad (4.1)$$

The response can be represented by a state function  $\psi(y)$  representing for example displacement in a certain direction. This function can be incorporated as a constraint in the optimisation, in which it is formulated as a threshold, for example  $\psi(y) \leq 0$ . If  $\psi(y)$  is represented by the displacement vector in a discrete finite element problem, then  $\psi(y) = \psi(u(x))$  where  $u$  is the displacements of individual nodes. The displacement vector  $\mathbf{a}$ , containing the displacement  $u$  of all nodes, is determined by the equilibrium:

$$\mathbf{a}(x) = \mathbf{K}(x)^{-1}\mathbf{f}(x) , \quad (4.2)$$

where  $\mathbf{K}$  is the system stiffness matrix and  $\mathbf{f}$  is the system force vector. This means that the optimisation can be formulated with the equilibrium constraint incorporated in the state function

$$\left\{ \begin{array}{l} \min_x \quad \xi(x) \\ \text{subject to} \quad \psi(u(x)) \leq 0 \end{array} \right. . \quad (4.3)$$

The optimisation is solved by evaluating the derivative  $\xi'(x)$ . In the context of optimising geometry,  $x$  will represent a geometrical feature. Depending on what geometrical feature  $x$  is representing, the optimisation can be categorised as:

*Topology optimisation:*  $x$  represents the connectivity of the domain, the positioning of material in the design domain is determined.

*Shape optimisation:*  $x$  represents the limit of the state function. The limit could be defined as different parameters, some physical quantity is minimised.

*Size optimisation:*  $x$  represents a parameter such as the cross-sectional areas of members, the optimal solution is determined minimising a physical quantity, for example the deflection.

It is possible to define the objective function to incorporate several objectives. If there are  $n$  objectives, it will not be possible to find a distinct solution that optimises all objectives at the same time. The objectives are weighted using scalars, by varying the weights of the objectives, different optimal points can be determined. In these points, no objective can be improved without worsening other objectives [23].

## 4.2 Design Strategy of Adaptive Structures

Adaptive structures can be designed by determining the optimal geometry based on different load cases, and finding a configuration that enables the actuators to efficiently transform the structure into all of the determined optimal shapes. Reksowardojo et al. [7, p.2] presents an energy based design method for adaptive reticular trusses. The trusses contain linear actuators that are fitted within some elements. The method is divided in two parts:

1. Optimisation of the geometry and internal forces to find target shapes for each load case, and optimisation of the element cross-sectional areas to minimise embodied energy.
2. Optimisation of actuator placement to steer the structure into the target shapes.

Figure 4.1 illustrates how shape and load-path optimisation is used to find the optimal cross-sectional areas, followed by the the optimal layout of actuators being determined.

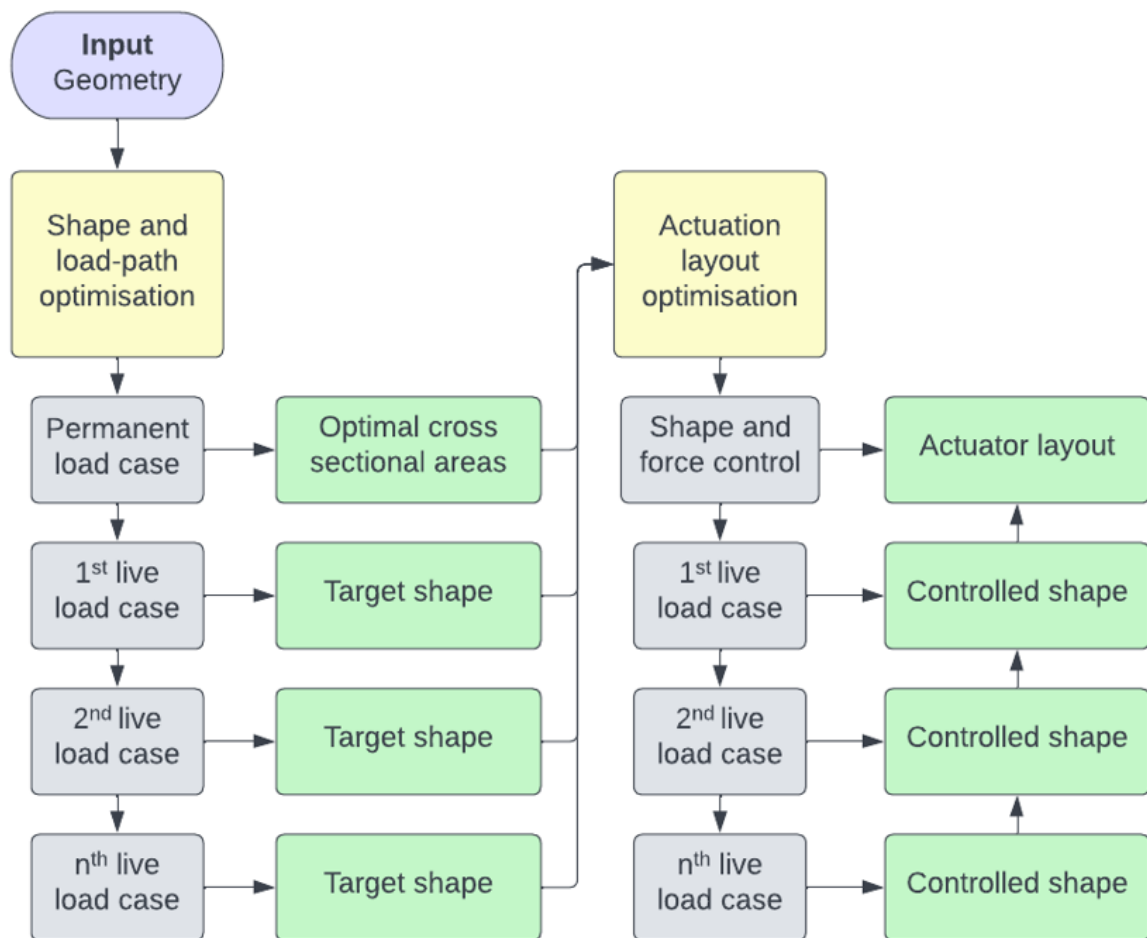

**Figure 4.1:** Design method of adaptive truss.

## 4.2.1 Shape and Internal Load-Path Optimisation

This part of the method is denoted by  $\chi$ . It is a mapping between external load  $\mathbf{p}$ , target shapes  $\mathbf{d}^t$  and internal forces  $\mathbf{f}^t$ . The subscript t stands for target.

$$\left\{ \begin{array}{l} \chi : \mathbf{p}_j \rightarrow (\mathbf{f}_j^t, \mathbf{d}_j^t) \\ \mathbf{p}_j \rightarrow \mathbf{f}_j^t(\mathbf{p}_j) \\ \mathbf{p}_j \rightarrow \mathbf{d}_j^t(\mathbf{p}_j) \end{array} \right. \quad j = 0, 1, 2, \dots, n^p \quad . \quad (4.4)$$

Inputs of structural topology,  $n^n$  nodes and  $n^e$  elements. The reticular structure can be in 2 or 3 dimensions, the amount of degrees of freedom is determined as  $n^d = n^n \times dim$  where  $dim$  is 2 or 3. An initial geometry is defined as  $\mathbf{d}^{\text{input}} \in \mathbf{R}^{n^d}$ . Design variables are the cross-section areas  $\alpha \in \mathbf{R}^{n^d}$ , the internal forces  $\mathbf{f} \in \mathbf{R}^{2 \times n^e}$  and nodal positions  $\mathbf{d}^t \in \mathbf{R}^{n^d}$ . All inputs are defined in a vector

$$\mathbf{x} = [\alpha \ \mathbf{f}_0 \ \dots \ \mathbf{f}_j \ \dots \ \mathbf{f}_{n^p} \ \mathbf{d}_0^t \ \dots \ \mathbf{d}_j^t \ \dots \ \mathbf{d}_{n^p}^t]^T, \quad (4.5)$$

where  $i$  refers to the  $i_{th}$  element and  $j$  to the  $j_{th}$  load case.  $n^p$  is the total number of load cases, which means there are also  $n^p$  nodal position vectors  $\mathbf{d}^t$  and internal force vectors  $\mathbf{f}$ . The cross-sectional areas  $\alpha$  remains the same, so there is just one vector. To avoid a direct matrix inversion,  $\mathbf{f}_j$  is composed by two vectors.

$$\mathbf{f}_j = [\mathbf{f}_j^t \ \mathbf{f}_j^0]^T. \quad (4.6)$$

$\mathbf{f}_j^t$  is the forces in equilibrium with the external load through a shape change  $\mathbf{d}_j^t$ .  $\mathbf{f}_j^0$  is the forces in equilibrium with the external load without shape control and computed on  $\mathbf{d}_0^t$ , which is the optimal shape under permanent load only. The structure is built in the shape  $\mathbf{d}_0^t$ .

Eq. (4.7) represents the embodied energy;  $g_i$  is the materials' energy intensity,  $\alpha_i$  is the cross-sectional area and  $\rho_i$  is the density of the  $i_{th}$  element.  $l_{ij}$  is the length of the  $i_{th}$  element for the  $j_{th}$  load case.

$$\sum_{i=1}^{n^e} g_i \alpha_i l_{i0} \rho_i \quad (4.7)$$

An optimisation is formulated with the objective to minimise the embodied energy given by eq. (4.7). The solution must maintain force equilibrium and fulfill ULS-constraints at all time. The optimisation is subject to several constraints. A more detailed description explaining all the constraints in the optimisation is available in Reksowardojo et al. [7].



## 4.2.2 Actuator Layout Optimisation

The actuator layout should be optimised to achieve the shapes determined by  $\chi$ . A global search method called "constrained simulated annealing" is used. Force and shape control is used to evaluate layouts. Force equilibrium, stress constraints and geometric compatibility are considered. The similarity between controlled shapes and target shapes for each load case are compared for different layouts. This is combined into a "Tanimoto Index"  $Q$ , used to evaluate the layouts:

$$Q = \frac{1}{n^p} \sum_{j=1}^{n^p} \frac{(\Delta \mathbf{d}_j^c)^T \Delta \mathbf{d}_j^t}{(\Delta \mathbf{d}_j^c)^T \Delta \mathbf{d}_j^c + (\Delta \mathbf{d}_j^t)^T \Delta \mathbf{d}_j^t - (\Delta \mathbf{d}_j^c)^T \Delta \mathbf{d}_j^t} . \quad (4.8)$$

$\Delta \mathbf{d}^t$  is the nodal displacement vector between the deformed shape and target shape,  $\Delta \mathbf{d}^c$  is the nodal displacement vector between the deformed shape and the shape controlled through actuation.  $Q$  is a value between 0 and 1; the closer it is to 1, the closer the controlled shape is to the target shape. The layout is then chosen through the optimisation

$$\min_y - Q. \quad \text{s.t. eq. (4.10)} . \quad (4.9)$$

$$f_{ij}^c \leq \sigma_i^+ \alpha_i; \quad f_{ij}^c \geq \max(\sigma_i^- \alpha_i, -\frac{\pi^2 EI_i}{l_{ij}^2}) \quad (4.10)$$

$y \in \mathbf{Z}^{n^{\text{act}}}$  is a vector of element indices that are assigned to active elements.  $n^{\text{act}}$  is the amount of actuators. The ULS is defined as a constraint for the formulation. This is a combinatorial problem with the search space

$$\frac{n^e!}{n^{\text{act}}!(n^e - n^{\text{act}})!} . \quad (4.11)$$

If the number of elements is large, the problem is computationally impossible to solve. To solve such a problem, a stochastic search based on "simulated annealing method" is formulated.

## 4.3 Finite Element Method

The parametric program utilises the finite element method to determine the displacements of the system in order to find a solution that fulfils the design criteria. The finite element method is used to numerically solve general differential equations with approximations. A region is divided into smaller *finite elements* and an approximation is carried out over each element, instead of approximating the entire region, more accurate approximations can be made when variables differ across the region [24]. The

method solves a domain of partial differential equations by discretizing a system into a finite number of elements. Element properties are defined in equations, element stiffness matrices are determined, external forces on the system are introduced and a global system is assembled. Nodal unknowns and element attributes such as forces, stresses and deflections can be determined [8].

The system is solved by the equilibrium

$$\mathbf{K}\mathbf{a} = \mathbf{f} , \quad (4.12)$$

where  $\mathbf{K}$  is the system stiffness matrix,  $\mathbf{a}$  is the nodal displacement vector, and  $\mathbf{f}$  is the force vector. The system used in the optimisation program involves non-linear bar elements. The non-linearity has to be included in the formulation of the system and accounted for in the solution.

In the parametric program created in this thesis, two-dimensional non-linear Green-Lagrange bar elements are used. The system is modelled using the total Lagrangian approach. Figure 4.2 shows a two dimensional bar element spanning from node A to node B with the length  $L$ , cross-sectional area  $A$  and Young's modulus  $E$ .



**Figure 4.2:** Two-dimensional bar.

Consider the element in Figure 4.2 The element tangent stiffness  $\mathbf{K}_t^e$  is determined by

$$\mathbf{K}_t^e = \mathbf{K}_0^e + \mathbf{K}_N^e + \mathbf{K}_u^e . \quad (4.13)$$

$\mathbf{K}_0^e$  is the global linear-elastic stiffness matrix of the element and is given by

$$\mathbf{K}_0^e = \mathbf{G}^T \bar{\mathbf{K}}^e \mathbf{G} , \quad (4.14)$$

where

$$\mathbf{G} = \frac{1}{L} \begin{bmatrix} x_2 - x_1 & y_2 - y_1 & 0 & 0 \\ -(y_2 - y_1) & x_2 - x_1 & 0 & 0 \\ 0 & 0 & x_2 - x_1 & y_2 - y_1 \\ 0 & 0 & -(y_2 - y_1) & x_2 - x_1 \end{bmatrix} , \quad (4.15)$$

and

$$\bar{\mathbf{K}}^e = \frac{EA}{L} \begin{bmatrix} 1 & 0 & -1 & 0 \\ 0 & 0 & 0 & 0 \\ -1 & 0 & 1 & 0 \\ 0 & 0 & 0 & 0 \end{bmatrix}. \quad (4.16)$$

$\mathbf{K}_N^e$  is the additional tangent stiffness caused by the normal force,  $N$ ,

$$\mathbf{K}_N^e = \frac{N}{L} \begin{bmatrix} 1 & 0 & -1 & 0 \\ 0 & 1 & 0 & -1 \\ -1 & 0 & 1 & 0 \\ 0 & -1 & 0 & -1 \end{bmatrix}. \quad (4.17)$$

$\mathbf{K}_u^e$  is the additional tangent stiffness caused by the displacements

$$\mathbf{K}_u^e = \frac{EA}{L^3} \begin{bmatrix} \mathbf{b}\mathbf{u} & -\mathbf{b}\mathbf{u} \\ -\mathbf{b}\mathbf{u} & \mathbf{b}\mathbf{u} \end{bmatrix}, \quad (4.18)$$

where

$$\mathbf{b}_u = \mathbf{b}\mathbf{u}^T + \mathbf{u}\mathbf{b}^T + \mathbf{u}\mathbf{u}^T, \quad (4.19)$$

determined by the displacements

$$\mathbf{u} = \begin{bmatrix} a_3 - a_1 \\ a_4 - a_2 \end{bmatrix} \quad (4.20)$$

and the differences of the nodal coordinates in  $x$  and  $y$

$$\mathbf{b} = \begin{bmatrix} x_2 - x_1 \\ y_2 - y_1 \end{bmatrix}. \quad (4.21)$$

### 4.3.1 Changing the Length of Elements

Changing the lengths of elements in a system of two-dimensional non linear bars impacts the equilibrium as displacements and internal forces are caused by the elongations. This must be taken into account when modelling a truss with the ability to change the lengths of the struts. In the inactive state of the truss, the base length of all the elements, with the normal force zero, is equal to the distance between the nodes that the elements span between. The forces applied in the equilibrium in combination with the system stiffness determine how the geometry changes, causing stresses and strains in the elements. Altering the length of the struts through actuation causes a change of geometry, that has an effect on the stresses and strains in the system.

Figure 4.3 illustrates an example of how elongating the struts causes internal forces in a system.

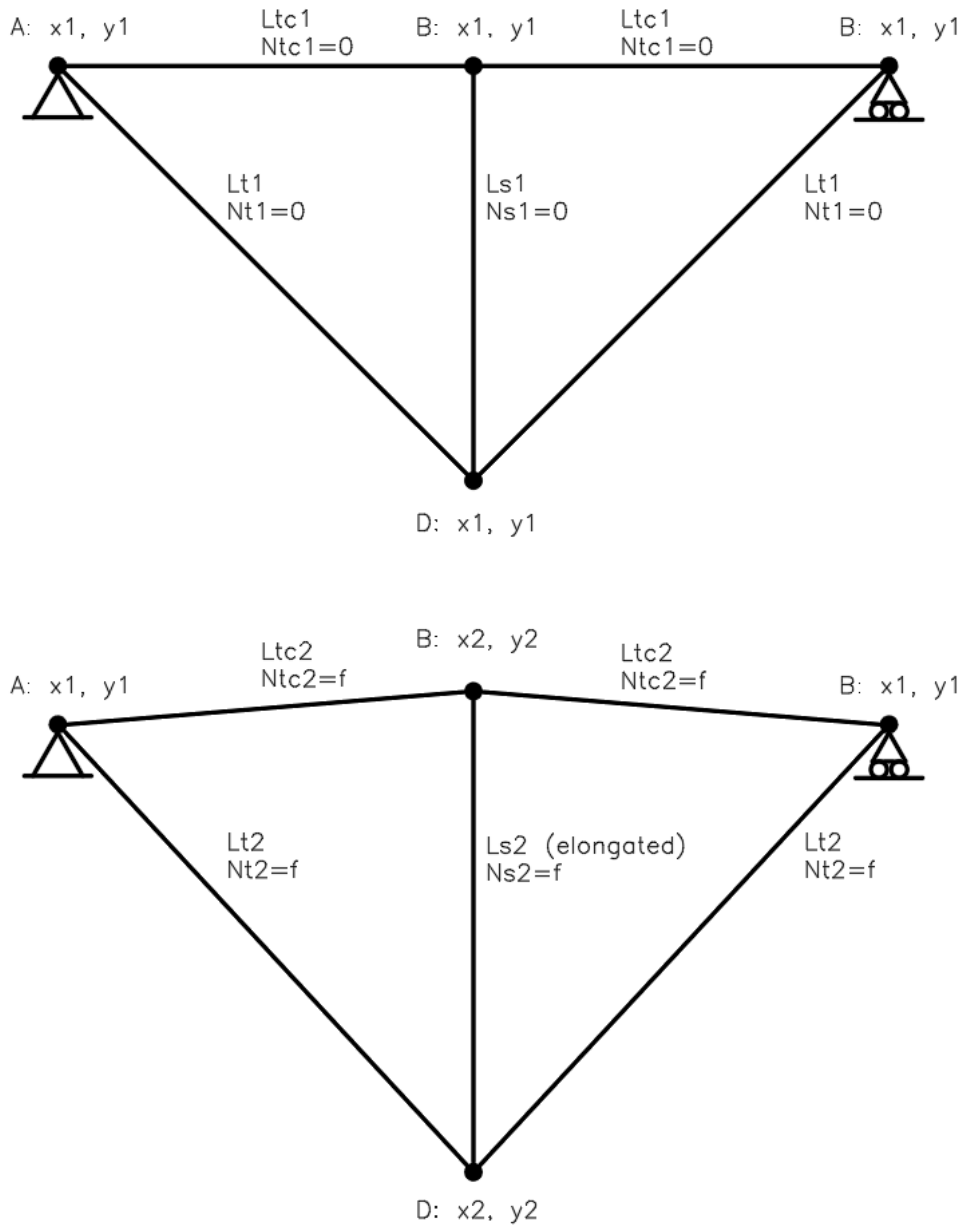

**Figure 4.3:** Upper: Geometry of a structure consisting of five bars. Lower: The same structure after the strut in the middle has been elongated. Nodes B and D are displaced by the elongation. The elongation causes strain in the rest of the elements, the corresponding normal forces cause strain in the elongated element as well.

$L_s$  = Length of strut,  $N_s$  = Normal force in strut.

$L_t$  = Length of tie,  $N_t$  = Normal force in tie.

$L_{tc}$  = Length of top chord,  $N_{tc}$  = Normal force in top chord.

$f$  = internal force caused by the change of geometry

Consider a two-dimensional bar as shown in Figure 4.2. The initial forces caused by the elongation of the struts must be determined as

$$\mathbf{f}_0 = \frac{EA\varepsilon_0}{L} \begin{bmatrix} 1 & 0 & -1 & 0 \\ 0 & 1 & 0 & -1 \\ -1 & 0 & 1 & 0 \\ 0 & -1 & 0 & 1 \end{bmatrix} \mathbf{c}_{fin}, \quad (4.22)$$

where final nodal coordinates are

$$\mathbf{c}_{fin} = \begin{bmatrix} x_1 + a_1 \\ y_1 + a_2 \\ x_2 + a_3 \\ y_2 + a_4 \end{bmatrix}, \quad (4.23)$$

and  $\varepsilon_0$  is the elongation of the struts by activation.

### 4.3.2 Solving the Non-Linear System

A non-linear system of two-dimensional bars can be solved using a modified version of the Newton Raphson method [25, ch.13]. When the tangent stiffness and initial forces caused by elongations are determined, an iterative process can be used to approximate the nodal displacement with respect to non linear effects. A modified version of the *Total Lagrangian formulation*, which is described in detail in Krenk [26, ch.2], is used. Figure 4.4 illustrates the iterative procedure.

The process starts with inserting the system tangent stiffness and the elongation of the active elements, in other words, a forced initial strain in some elements. The internal forces are determined according to eq. (4.24)-(4.29). Residual forces are determined as the difference between external forces and internal forces, only accounting for the non prescribed degrees of freedom. The displacement increments of each iteration are calculated and summarised to determine the total displacements. Because the normal forces and strains in the elements are dependent on the initial lengths, the initial lengths are updated in each iteration by updating the coordinates of the nodes. Once the residual forces are smaller than a set threshold, the solution has converged and an approximation of the total displacements has been determined.

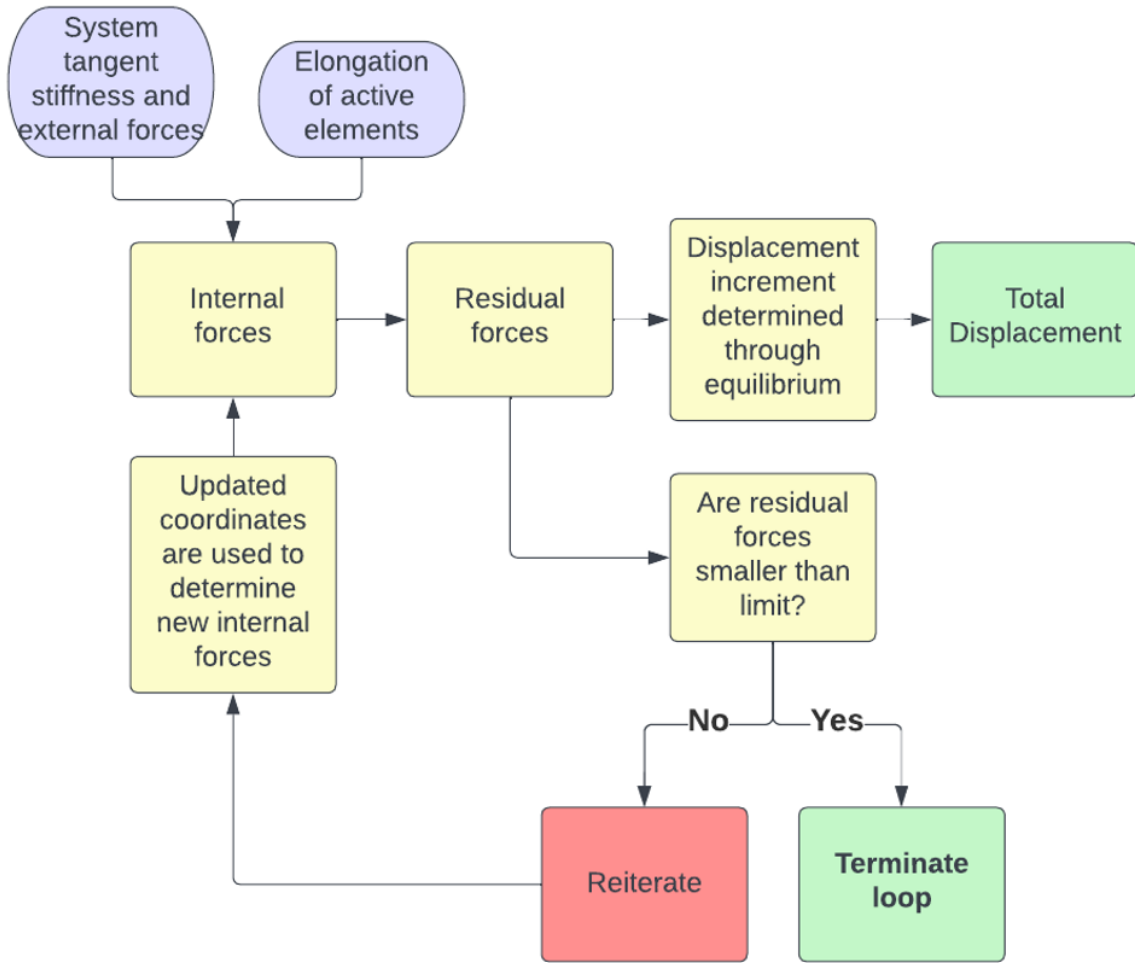

**Figure 4.4:** Solving the differential equation with the total Lagrangian formulation.

Consider a two-dimensional bar element according to Figure 4.2. The internal forces are determined as

$$\mathbf{f}_{\text{int}} = \frac{N}{\sqrt{L_{02}}} \begin{bmatrix} 1 & 0 & -1 & 0 \\ 0 & 1 & 0 & -1 \\ -1 & 0 & 1 & 0 \\ 0 & -1 & 0 & 1 \end{bmatrix} (\mathbf{c}_0 + \mathbf{a}^{eT}), \quad (4.24)$$

where the normal force is determined as

$$N = EA\varepsilon_g + EA\varepsilon_0, \quad (4.25)$$

and the Green strain is:

$$\varepsilon_g = \frac{1}{L_{02}} (\mathbf{c}_0 + 0.5 \cdot \mathbf{a}^{eT})^T \begin{bmatrix} 1 & 0 & -1 & 0 \\ 0 & 1 & 0 & -1 \\ -1 & 0 & 1 & 0 \\ 0 & -1 & 0 & 1 \end{bmatrix} \mathbf{a}^{eT}, \quad (4.26)$$

where

$$L_{02} = \mathbf{c}_0^T \begin{bmatrix} 1 & 0 & -1 & 0 \\ 0 & 1 & 0 & -1 \\ -1 & 0 & 1 & 0 \\ 0 & -1 & 0 & 1 \end{bmatrix} \mathbf{c}_0. \quad (4.27)$$

The original coordinates are

$$\mathbf{c}_0 = \begin{bmatrix} x_1 \\ y_1 \\ x_2 \\ y_2 \end{bmatrix}, \quad (4.28)$$

and the displacements are

$$\mathbf{a}^e = \begin{bmatrix} a_1 \\ a_2 \\ a_3 \\ a_4 \end{bmatrix}. \quad (4.29)$$





# 5 The Parametric Design Program

In this chapter the parametric design program is described. Section 5.1 presents three conceptual designs for adaptive two-dimensional frame structures, two of which have been chosen for implementation in the program. Section 5.2 explains the buildup of the program. Sections 5.3 and 5.4 describe the data that has to be provided by the user as input, and what the design program returns as output.

## 5.1 Conceptual Design

The configuration of the structure is determined based on it consisting of a continuous top chord, upon which load is applied, and vertical struts that may be altered in length during the lifespan of the structure. Ties are positioned to transfer tensile stresses and effectively transfers loads towards the supports, these may be diagonal or horizontal. No structural elements are placed above the load bearing top chord.

Three conceptual topologies are developed. The design program is then created for two of them, to allow results to be compared. The concepts are presented in the sections 5.1.1-5.1.3.

### 5.1.1 Pratt Truss

A Pratt truss has all vertical members in compression and all diagonal members in tension when downwards load is acting on it. It is a commonly used configuration for trusses and an effective solution for large span horizontal structures. It is considered material efficient and is simple to construct [27]. Figure 5.1 displays a Pratt truss modelled in the software "PointSketch".

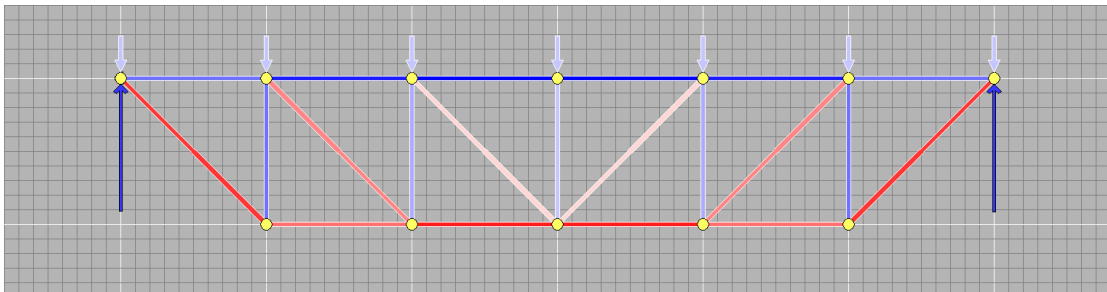

**Figure 5.1:** Pratt truss in PointSketch. The forces acting on the structure is represented by arrows and the yellow nodes are all joints. All elements are bars, bars in tension are red and bars in compression are blue.

This configuration is statically determinate in one plane. Configuring the cable-tensioned beam as a truss means all elements, including the top chord, are axially

loaded in theory. The requirement of bending stiffness in the top chord is then limited to just handle the bending caused by load applied between the nodes along the top chord. There is no need for the top chord to be continuous in a truss.

### 5.1.2 Truss with Crossing Diagonals and Without Bottom Chord

This configuration is displayed in Figure 5.2. Each strut connects to two diagonal ties at their lower end, one in each direction. The diagonal ties run from the tip of the struts to the points where the adjacent struts connect to the top chord. All diagonals are in tension, all vertical elements, and the entire top chord is in compression. This configuration is statically determinate in one plane. This is a truss as well, meaning the top chord does not have to be continuous.

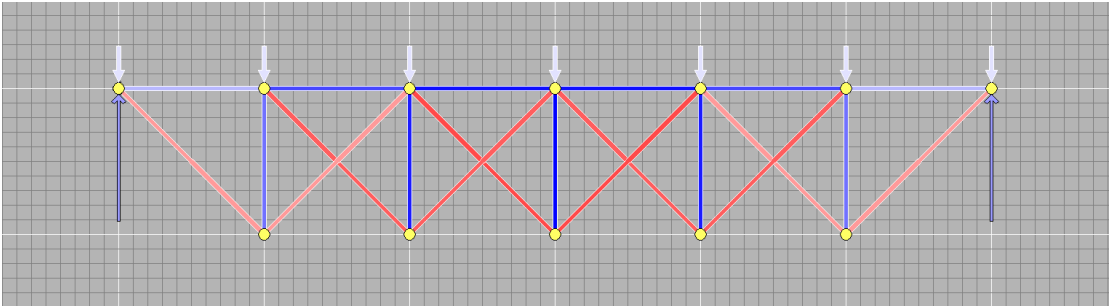

**Figure 5.2:** Truss with crossing diagonals and without bottom chord in PointSketch. Forces on the structure are represented by arrows, bars in tension are red and bars in compression are blue.

### 5.1.3 Cable-Tensioned Beam

A cable-tensioned beam has no diagonal elements apart from in the frames adjacent to the supports. The idea of the system is that tension in the strut compresses the lower part of the top chord to bend it upwards. Figure 5.3 displays a model of a cable-tensioned beam in PointSketch modelled similarly to the previously displayed trusses.

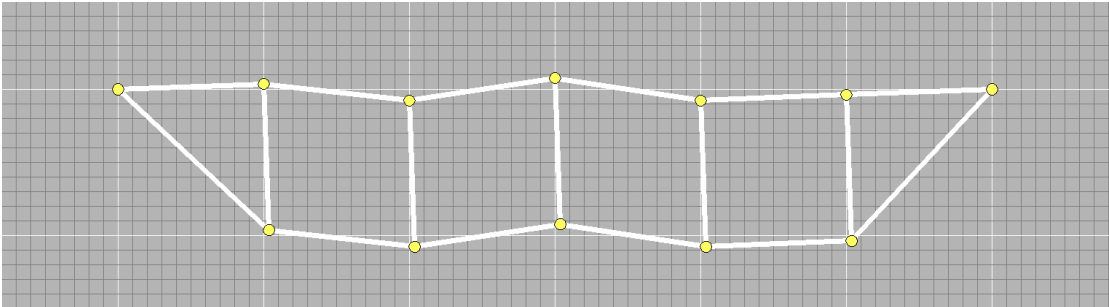

**Figure 5.3:** Conventional cable-tensioned beam modelled in PointSketch. The system displays a mechanism

If the system is modelled as it is in Figure 5.3, there can be no equilibrium of forces in several of the nodes in the undeformed shape, creating a mechanism. Loads must be able to be transferred to the supports. The system requires initial displacements of nodes in order for vertical nodal reaction forces to counter forces applied to the system, so that static equilibrium can be achieved in the nodes. If the top chord is modelled as a continuous beam, the rotational stiffness of the beam is able to transfer the loads to the supports. PointSketch does not have the ability to draw beams, this can be modelled by drawing a shallow truss representing the top chord, as displayed in Figure 5.4.

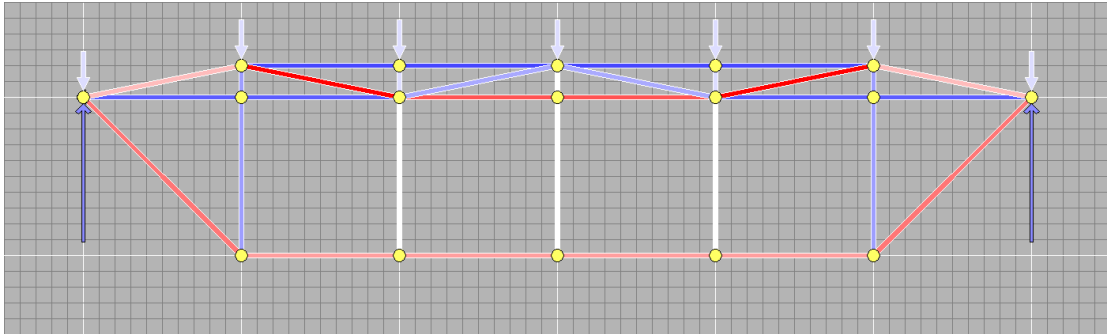

**Figure 5.4:** Conventional cable-tensioned beam modelled in PointSketch. The top chord has been modelled as a truss beam making the system statically determinate. Forces on the structure are represented by arrows, bars in tension are red and bars in compression are blue.

Since this is a cable-tensioned beam. The principle of the connections between the struts and top chord having to be positioned above the connection between the ties and the top chord explained in Section 2.5 must be applied here. This should be taken into account when determining the serviceability limit requirements since the relation must persist in the deflected state.

The illustration from PointSketch suggests that only the utmost struts are compressed, this is true in the undeformed state. In a deformed shape or a shape in which the other struts have been elongated so that the normal force in the ties may have a vertical force component acting on the node, load may be transferred through the other struts, so they are kept for now.

## 5.2 The Program

The program is created using Calfem in Python with Numpy. The program involves several iterative processes being run until convergence criteria are fulfilled. The program has been made for two different conceptual configurations of trusses. The user provides predefined information about the geometry, material properties and loads as inputs. The results provide information regarding required cross-sectional areas, and what the elongation of the struts need to be in order to fulfil the serviceability limit state criteria. Since the program is created with the purpose of illustrating the potential of adaptive structures, it is designed to present the effects of the function, as well as the potential material savings compared to a conventional solution.

The program performs two optimisations: It searches for the smallest cross-sectional areas of the members that fulfil the ultimate limit state requirements at all possible geometries from the inactivated state to the fully activated state. It also determines the minimum elongation of the struts required to prevent the serviceability limit from being exceeded. The optimisation of the cross-sectional areas can be formulated as

$$\begin{cases} \min & \sigma_e(A_{cs}, x, q, \varepsilon_0) \\ & A_{cs} \\ \text{subject to} & \sigma_e \leq f_y \end{cases}, \quad (5.1)$$

where the cross-sectional areas of the elements are  $A_{cs}$ , the base geometry of the truss is  $x$ , the stresses in the members are  $\sigma_e$ , the load is  $q$ , the elongations of the struts are  $\varepsilon_0$ , the deflections are  $u$ , the ultimate limit is  $f_y$ . Finding the smallest required elongation of the adaptive struts can be formulated as

$$\begin{cases} \min & u(A_{cs}, x, q, \varepsilon_0) \\ & \varepsilon_0 \\ \text{subject to} & u \leq u_{\max} \end{cases}, \quad (5.2)$$

and the maximum allowed deflection is  $u_{\max}$ .

"Python", a programming language which is open source and a common language known for its simple syntax, is used to script the program [28]. "Anaconda" was used for distribution of Python. "NumPy" is used, which is a package in Python used for scientific programming, allowing matrices and multi-dimensional arrays to be scripted. NumPy contains a set of functions simplifying mathematical operations [29]. For finite element calculations, "Calfem" is used, an educational program developed at the Division of Structural Mechanics at Lund University [30]. Calfem is available for python on GitHub. The code was written in the integrated development environment "Spyder", an application automatically installed with Anaconda.

The essence of the program is to determine the displacements of nodes. This is done by defining a finite element model containing two dimensional bars, formulating its stiffness matrix  $\mathbf{K}$ , the force vector  $\mathbf{f}$ , the boundary conditions and then solving the system through equilibrium to find the displacements  $\mathbf{a}$ . The displacements can then be compared to a convergence criterion. If the criterion is not fulfilled, the model is modified and recalculated. This process is done iteratively until convergence. The logic of the procedure is illustrated in Figure 5.5.

The first task for the program is to generate a model based on the inputs of nodes and topology as explained in detail in section 5.3. This is done by defining nodes and a topology. A stiffness matrix is assembled based on said topology. The force vector is determined by the inputs as well. Separate script has been formulated for each of the two design concepts since the logic used to generate the model differs, however, the procedure remains the same. By combining the two scripts a quantitative comparison can be evaluated automatically if so desired.

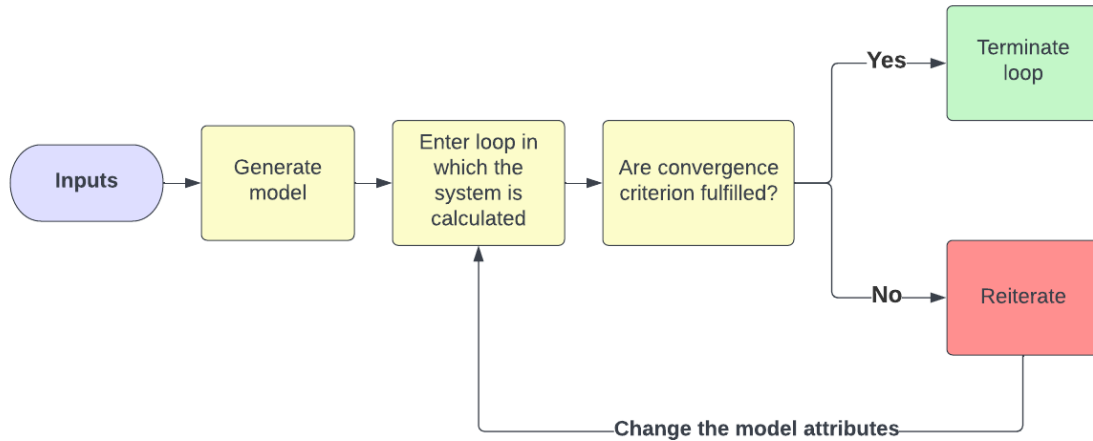

**Figure 5.5:** Program determining a system in an iterative process.

When the model is defined, the program enters a loop. Several loops are wrapped inside each other. The outer loops control the cross-sectional areas of the different element types, these loops solve the optimisation in eq. (5.1). In every iteration, the cross-sectional areas are increased in pre-defined intervals until the maximum stress is smaller than the ultimate limit capacity. An inner loop controls the adaptive elongation of the struts. Within the inner loop, the non linear system is solved according to the process described in section 4.4. Should the solution not be found within a certain number of iterations, the program will continue with a new set of cross-sectional areas. If the solution will not converge at any point within a certain limit of iterations of the outer loops, the program will terminate with an error message. The program will not present any solution with cross-sectional areas that did not converge in the inactivated state, or in a state where the elongation of the struts is smaller than the final one, as a valid setup. This is implemented to ensure that the structure will not fail at any elongations smaller than the final elongations required to reduce the deflection below the limit.

The inner loop solves the optimisation in eq. (5.2). As long as the deflection  $u$  is bigger than the limit  $u_{\max}$ , the loop continues and the base lengths of the struts are increased for every iteration. Whenever the cross-sectional areas are increased, the inner loop is reset and the elongation of the struts start increasing from zero again. The program is set up this way since larger cross-sectional areas of the bars changes the stiffness of the system and might reduce the required elongation. Figure 5.6 illustrates the iterative process of finding a combination of cross-sectional areas and elongation of the struts that fulfils the requirements.

To improve the understanding of the adaptive system, the first iteration of the inner loop determines the system when it is exposed to permanent load only, the second iteration determines it when it is exposed to permanent and variable load without activating. The first two iterations do not involve elongating the struts, the convergence criteria are blocked from converging in the first iteration.

If the convergence criteria of displacement are fulfilled and the stresses are within

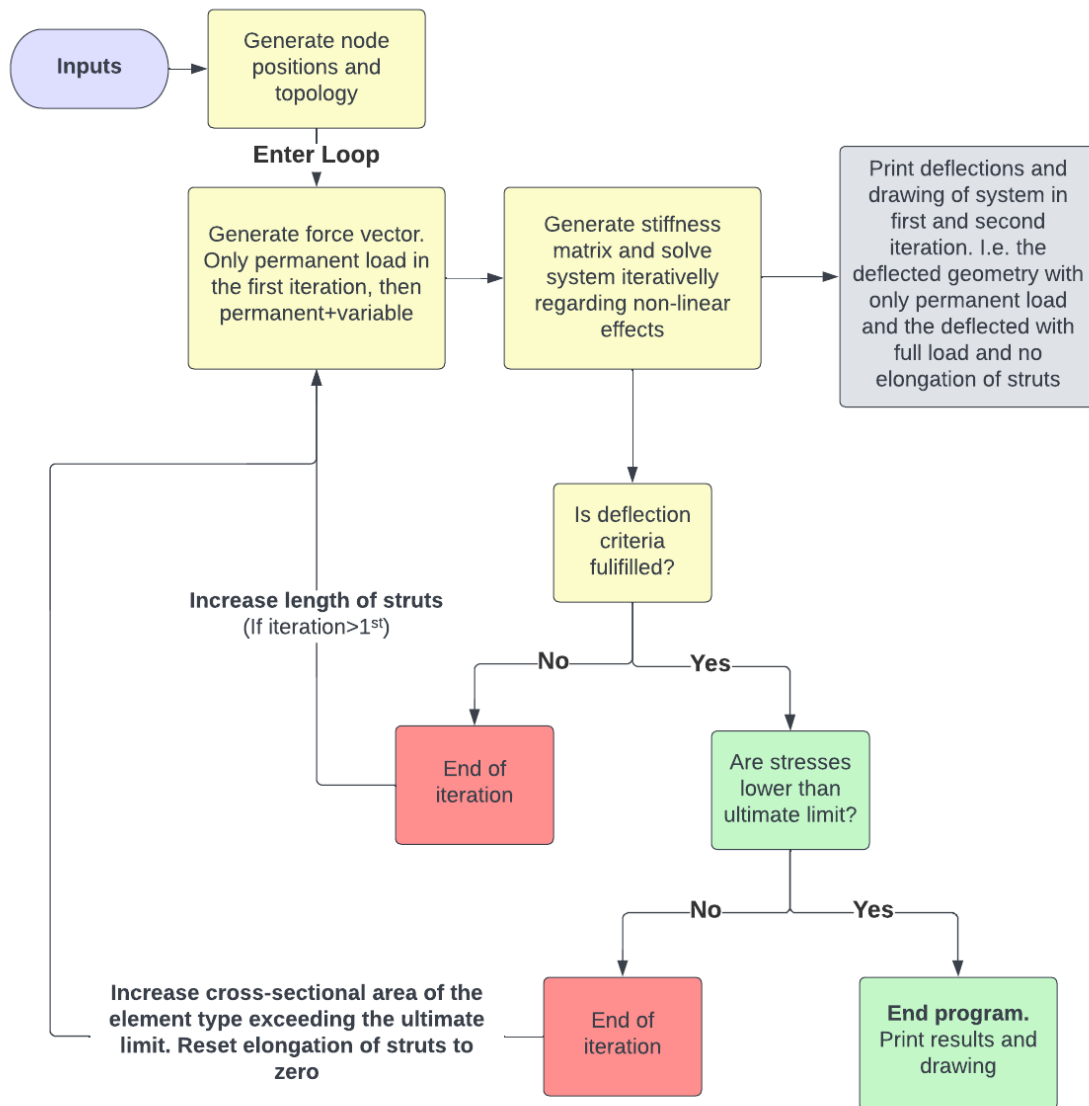

**Figure 5.6:** Program calculating a system in an iterative process.

the limits, the program terminates and a final result is presented, it has succeeded and found a solution that fulfils all stated requirements. If the program cannot find this within a set amount of iterations, it will terminate with an error message telling the user it has ran out of iterations. Another situation that terminates the program is when the permanent load causes to large displacements in the first iteration, the structure should be able to fulfil the serviceability limit requirements when exposed to permanent load without any actuation. If the program is terminated it will provide information about the reason that supports the user in altering the inputs to a setup that it will find a solution.

## 5.3 Inputs

The design program is parametric. A set of inputs are defined by the user and a solution is determined by the program. The inputs required by the program are presented in sections 5.3.1-5.3.4.

### 5.3.1 Material properties

Initial cross-sectional areas for the first iteration of the process are defined by the user. To find the optimised cross-sectional areas, the input should be very small, since the program will increase the areas until it converges. If the program is run with input areas larger than the optimised, it will still determine the elongation required to not exceed the deflection limit. When the program has been run to find the cross-sectional areas, it can be re-run with the resulting areas as input to improve the speed of the program. The Young's modulus is defined as an input, this enables the program to show results based on different materials being used. Defining the specific CO<sub>2</sub>e emissions and density of the material enables the program to determine the climate impact of the adaptive solution and compare it to a conventional alternative. A safety factor against failure that reduces the ultimate capacity of the material is defined as an input.

### 5.3.2 Geometry

The geometry of the structure is divided into frames along its length. Figure 5.7 displays a few examples of possible geometries. One frame starts and ends with a strut, except for the utmost frames which span from the utmost struts to the supports. What elements make up a frame depends on which conceptual system is being analysed. The amount of frames must be set to an even number. The height and the length of the frames are defined. Combining the parameters that determine the length of the frames and the amount of frames, allows any total length of trusses to be modelled. The height of the frames is the total original height of the system.

### 5.3.3 Loading

Permanent and variable loads are defined as uniformly distributed linear loads acting vertically downwards on the top chord. If it is desired to analyse another type of load, this can be done with slight modifications to the load input, it is then possible to add a point load or other non-uniformly distributed loads. There is the possibility to choose what portion of the variable load should be applied, changing this setting is the same as altering the input of variable load by the corresponding factor.

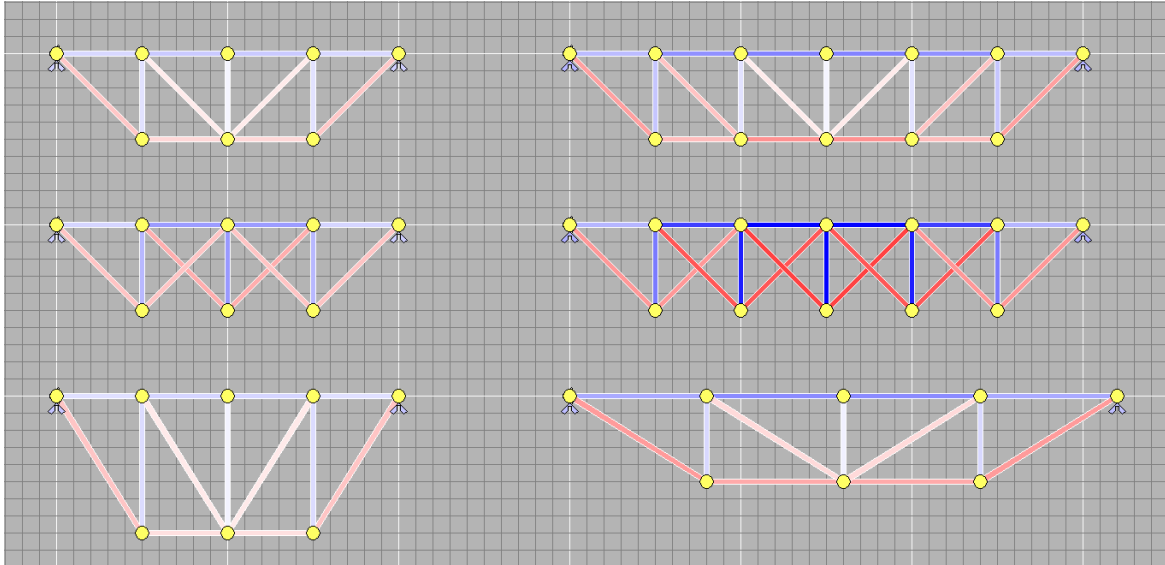

**Figure 5.7:** Examples of truss geometries drawn in PointSketch. First row: Pratt truss with four frames (left), Pratt truss with six frames (right). Second row: crossing diagonals with four frames (left), crossing diagonals with six frames (right). Third row: Pratt truss with four frames and increased height (left), Pratt truss with four frames and increased length of frames (right).

### 5.3.4 Serviceability Limit State Maximum Deflection

This is expressed as a variable that may for example be based on the length of the system. It can also be defined as a value based on a limit determined by some other requirement. This limit is the convergence criteria for the displacement of all nodes along the top chord.

## 5.4 Outputs

When the program has finished successfully, results are presented to the user. The outputs are divided into categories according to Sections 5.4.1-5.4.4.

### 5.4.1 Program Performance

The program outputs the time required to find a converging solution where the adaptive function has reduced the deflection below the limit and no stresses exceed the ultimate limit. The output provides information at which iteration it converged on with respect to cross-sectional areas and elongation of the struts. The program states a confirmation that the solution has converged on every iteration determining the elongations of the struts with the final cross-sectional areas.



### **5.4.2 Displacements and Activation**

Maximum allowed deflection (the limit) is stated as a reference. Coordinates of the nodes along the top chord and the maximum deflection, displaced by permanent load in the inactivated state, are presented. This is followed by the same information in the case when variable load is acting on the structure in the inactivated and activated state respectively. These outputs help clarify the effects of the adaptive function and a confirmation that it helps in fulfilling the serviceability requirements. The displacement when the adaptive function is activated when only permanent load is present is also presented. This data confirms whether it is required to turn off the adaptive function in order to not have a two large deflection in the other direction. The elongation of each strut that reduces the displacements of the nodes below the limit is presented.

### **5.4.3 Element Dimensions and Stresses**

Cross-sectional areas of the ties, top chord, and struts are presented. The maximum stress utilisation is presented, this is the maximum utilisation that can occur at any activation rate with the determined cross-sectional areas. The stresses might be lower in the fully activated state. The maximum normal forces of each element group is presented in the inactivated state with permanent load, and the activated state with variable load. The range of the normal forces can be used to determine the stress amplitude for fatigue analysis.

### **5.4.4 Carbon Dioxide Emissions and Non-Adaptive Alternative**

CO<sub>2</sub>e emissions caused by the material used in the determined structure is presented. The cross-sectional areas required to fulfil the serviceability limit state requirements and the maximum deflection without the elongation of the struts is then presented, together with the CO<sub>2</sub>e emissions of that configuration. This output illustrates the potential material savings and associated emission reduction potential achieved by using adaptivity.



# 6 Using the Program

This chapter illustrates how the program can be used to evaluate different design alternatives for adaptive structures. An analysis is performed, aiming to determine which design alternative, from a selection, causes the least amount of CO<sub>2</sub>e emissions. Some other data is collected and analysed as well. The analysis is performed in different circumstances regarding span, load case and serviceability limit to see if the result differs. This can be described as a manual optimisation using the program to find the most efficient solution. The program is run with different combinations of inputs to produce results that are compared to each other.

## 6.1 Formulating the Optimisation

The objective is to achieve the smallest CO<sub>2</sub>e emissions caused by the material used. The combinations of inputs are denoted as  $x$ . The structure determined by the program can be defined as  $y(x)$ . The CO<sub>2</sub>e emissions from the determined structure are  $z(y(x))$ . The solution is determined to fulfil the criteria of the maximum deflection being smaller than a certain threshold, the maximum deflection is defined as  $u(y(x))$ . The following optimisation is performed

$$\begin{cases} \min & z(y(x)) \\ \text{subject to} & u(y(x)) \leq u_{\max} \end{cases} \quad (6.1)$$

$z$  is minimised but the sought information is; which  $x$  yields the smallest  $z$ .

## 6.2 Input Combinations

The inputs can be divided into *circumstances* and *design alternatives*. The circumstances are the situations which to find the optimal solution for, while the design alternatives are features of the structure that can be changed within the optimisation. The optimisation is performed once for each combination of circumstances.

### 6.2.1 Circumstances

Circumstances that were altered in the analysis were the span, the load case and the serviceability limit state criteria, presented in Table 6.1. These were kept the same during each optimisation. Both cases were run in combination with both spans. Two

serviceability limit state criteria were tested for each combination, L/300 and L/1000, resulting in a total of eight combinations of circumstances.

**Table 6.1:** Alternative circumstances in example analysis.

<b>Span (m)</b>	16	64
<b>Permanent/Variable load (N/m)</b>	1000/3000	1000/8000
<b>SLS Max. Deflection (m)</b>	L/300	L/1000

## 6.2.2 Design Alternatives

Alternative parameters are presented in Table 6.2. The analysis was performed with the structure made entirely of steel (S355) or timber (C30). Three different conceptual designs were subjected to the analysis. Each of them were analysed with the length divided into four frames and eight frames. This results in eight design alternatives. The safety factor reducing the ultimate capacity was set to 0.7.

The analysis was ran with the height of the truss set to the length divided by 16. If a larger height was required, likely due to the permanent load causing deflections to exceed the limit, the height was increased to a maximum of the length of the frames. Another way to prevent the limit from being exceeded by permanent load would be to force larger cross-sectional areas, this was not implemented in the analysis, meaning the cross-sectional areas are always optimised with regards to stress capacity.

**Table 6.2:** Design alternative parameters in example analysis.

<b>Design Concept</b>	Pratt Truss	Crossing Diagonals
<b>Material</b>	Timber (C30)	Steel (S355)
<b>Amount of Frames</b>	4	8

Figure 6.1 shows the different alternative topologies tested in the analysis. The Figure displays them with the total length of 16 metres, they were also tested with a total length of 64 metres.

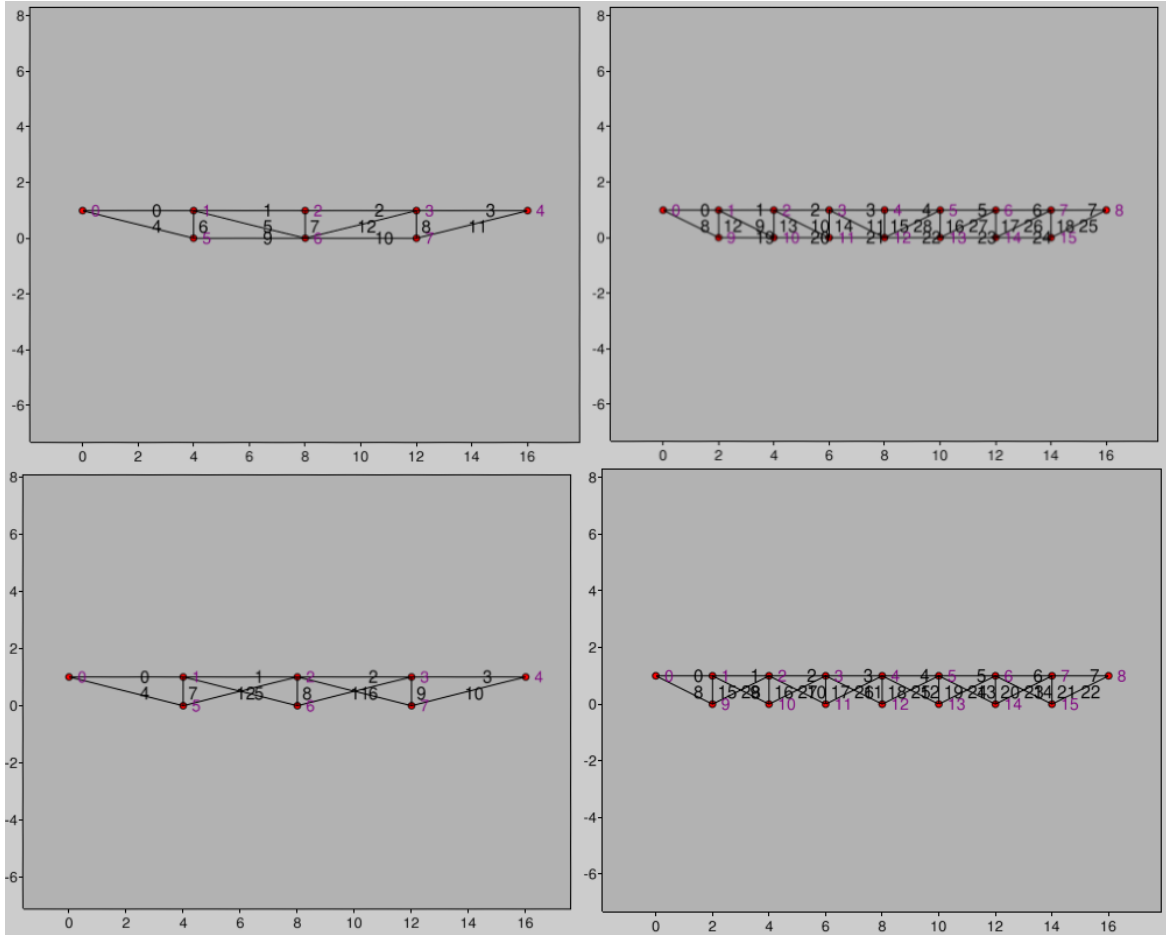

**Figure 6.1:** First row: Pratt truss with four frames (left), Pratt truss with eight frames (right). Second row: crossing diagonals truss with 4 frames (left), crossing diagonals truss with eight frames (right).

## 6.3 Results

Appendix 1 contains the full results of the analysis. Important outtakes are presented here.

### 6.3.1 CO<sub>2</sub>e Emissions

CO<sub>2</sub>e emission savings achieved by the adaptive truss compared to its corresponding non-adaptive alternative range between 28 % and 89 %. The design alternative causing the least emissions is the Pratt truss made of timber with four frames, for all eight combinations of circumstances. The worst performing design is the crossing diagonals made of steel with eight frames, it causes the most emissions in six of the circumstances and does not fulfil the deflection criteria with permanent load in the other two. For example; in the circumstances with a span of 64 meters, the load 1.0/8.0 kN and the limit criterion of L/300, the Pratt/timber/four (concept/material/frames) design causes 565 kg of CO<sub>2</sub>e emissions, while the cross/steel/eight design causes 38,690 kg of CO<sub>2</sub>e emissions.

The trend is that the Pratt truss performs better than the crossing diagonals, timber performs better than steel and four frames performs better than eight frames, with regards to CO<sub>2</sub>e emissions.

Comparing the alternative structures without the adaptive function provides the same results with the Pratt truss outperforming the crossing diagonals and timber outperforming steel. However, using eight frames in the Pratt truss slightly reduces emissions in a majority of the circumstances, the difference is very small though, and might be down to the cross iterative increment of cross-sectional areas. In the same example of circumstances, the non-adaptive Pratt/timber/eight design causes 1049 kg of emissions, the non-adaptive Pratt/timber/four design causes 1068 kg of emissions, and the non adaptive cross/steel/eight design causes 318,102 kg of emissions.

### 6.3.2 Elongations

The total elongations in all struts combined required to fulfil the serviceability limit state criteria are compared. The results are displayed in Tables 6.3 and 6.4. For all circumstances except for one, the design requiring the least elongations are crossing diagonals, and for all circumstances, the design requiring the most elongations are Pratt trusses. Timber trusses tend to require more elongation than steel trusses, and trusses with four frames tends to require more than trusses with eight frames.

**Table 6.3:** Designs requiring the least total elongations of struts to fulfil serviceability limit state criteria.

Circumstances			Design		
Span (m)	Load P/V (kN)	Max Deflection	Design Concept	Material	Amount of Frames
16	1/3	L/300	Pratt	Steel	8
16	1/3	L/1000	Cross	Steel	4
16	1/8	L/300	Cross	Steel	8
16	1/8	L/1000	Cross	Timber	8
64	1/3	L/300	Cross	Steel	4
64	1/3	L/1000	Cross	Steel	4
64	1/8	L/300	Cross	Steel	8
64	1/8	L/1000	Cross	Steel	8

**Table 6.4:** Designs requiring the most total elongations of struts to fulfil serviceability limit state criteria.

Circumstances			Design		
Span (m)	Load P/V (kN)	Max Deflection	Design Concept	Material	Amount of Frames
16	1/3	L/300	Pratt	Timber	4
16	1/3	L/1000	Pratt	Steel	8
16	1/8	L/300	Pratt	Timber	4
16	1/8	L/1000	Pratt	Timber	4
64	1/3	L/300	Pratt	Timber	4
64	1/3	L/1000	Pratt	Steel	8
64	1/8	L/300	Pratt	Timber	4
64	1/8	L/1000	Pratt	Timber	4

### 6.3.3 Deflections

The smallest deflections without activation is achieved by Pratt trusses made of steel, Crossing diagonal trusses generally deflect more than Pratt trusses in the inactivated state. The deflection in the activated state is controlled to be below the limit, this is achieved by all of the trusses that does not have a to large deflection due to permanent load.

### 6.3.4 Upwards Deflection in Unloaded State

The upwards deflection when the variable load is not acting on the structure, and the elongation of the struts is applied, might determine if the elongation should be adaptive or constant. If the deflection is larger than the limit of deflection in the upward direction, adaptivity is required, if not, it might as well be constant. In this analysis, the upwards deflection is compared to the limit of downwards deflection. The results show that the upwards deflection is always smaller than the limit for Pratt trusses subject to the limit of L/300. It is sometimes smaller than the limit for crossing diagonal trusses subjected to a the variable load of 3 kN and the limit L/300. It is always larger than the limit when the limit is L/1000.





# 7 Conclusion

The analysis of the models created with the program suggests that this adaptive system has the potential to reduce the material required in two-dimensional trusses to fulfil serviceability limit state requirements of deflection. Fairly small adjustments of the lengths of the struts have significant impact on the deflection. While the adaptivity has the potential to reduce the climate impact of structures, more simple methods such as choice of material and topology optimisation can be at least as significant.

## 7.1 Challenges of Adaptive Structures

A major difficulty of designing adaptive structures is that they must be designed with regards to different geometries and different load situations at the same time. This limits the possibilities to perform traditional hand calculations with substance for design. Computational programs are required to analyse the structures. Such programs can be created with the help of finite element modelling and optimisation.

The program created in this thesis can be used to show that the material cost of cross-sectional areas of the elements in order to fulfil serviceability limit state can be reduced with an adaptive system. It does not provide any information on the material cost of adding the adaptive system as this is beyond the scope of the thesis. It does not determine the energy consumption of the actuators, this is also beyond the scope and is highly dependent on the circumstances that the system is implemented in. Material consumption of connections has not been included in the analysis either, connections are present whether the system is adaptive or not. However, in timber trusses, connections are often made in steel, which can significantly impact the total CO<sub>2</sub>e emissions of the truss. This should be taken into account when comparing the results of the timber trusses to the results of the steel trusses. These topics are suggestions for further studies under the subject and would complement this research.

Dynamic behaviour, fatigue, design of connections, design of actuators, engines for the actuators, sensors and control are other topics that must be considered to fully develop an automatic adaptive structural system. The models created by the program in this thesis can be used as subjects for further research. The calculations used to determine elongations of struts can for example be used to create a control unit. Output of normal forces can be used to evaluate the structure with regards to fatigue. When the actuators are designed, they must be designed to withstand the same stresses as the cross-sections determined by the program. Sledden [31] treats dynamic behaviour and explores using adaptivity to reduce resonance effects in structures.

## 7.2 Improvements of the Design Program

While the design program fits the purpose of illustrating how these two to specific adaptive systems work and, an evaluation of some different alternatives using these concepts can be performed using it, there is still much potential for further development. If compared to the design system developed by Reksowardojo et al. [7]; this parametric process is much more limited and caters only to determine and optimise the predefined geometrical concepts, whereas Reksowardojo et al. [7]'s system determines a geometry within the process.

An advantage of limiting the program to work with pre-specified topologies is that the computational requirements to find a solution is significantly decreased compared to evaluating a big amount of setups. It is also worth considering that it is more convenient to streamline manufacturing for a limited amount of topologies than it would be if any topologies are allowed. Implementation of automatic comparative analyses similar to the one performed in this thesis should be performed to improve the capabilities of the program.

Currently, the load is input as a characteristic value. An improvement allowing load cases and combinations to be defined based on Eurocode should be carried out. This implementation could resemble the way loads are defined in programs such as Strusoft's Frame Analysis. Elongations should always be determined based on characteristic load values.

For the program to be independently used for design of adaptive structures, problems such as dynamic behaviour and capacity with regards to fatigue should be considered by the program, so that any solution presented by the program will fulfil requirements with regards to these issues. It is also of high interest to determine the material consumption of connections and the actuator system, as well as the energy consumption of activating the actuators, so that the system can be evaluated as a whole.

## 7.3 Assessment of Results From Model and Analysis

The physical model acted as expected. The model was slightly asymmetrical and the equipment used was not sufficient to take any measurements. It was sufficient to prove that elongating the struts indeed did counter the deflection from load. It would be desirable to build a more sophisticated model, preferably one that is built according to a design determined by the program, so that it can be used to compare with the calculated results.

Results from the analysis illustrates the potential material savings of adaptive structures. Overlooking all the results where the advantage of implementing an adaptive function is questionable due to the upwards deflection caused by increasing the length of the struts being smaller, the adaptive function allows the CO<sub>2</sub>e emissions to be reduced by 89 %. The smallest saving is 62 %.

The results clearly suggest that timber trusses cause significantly less CO<sub>2</sub>e emissions than steel trusses. For adaptive trusses, the smallest ratio between emissions from the most efficient steel truss and timber truss is 31.3 and, for non-adaptive alternatives, the corresponding ratio is 30.8. If connections with low CO<sub>2</sub>e emissions can be designed, timber structures can be built with much smaller emissions than steel structures. The choice of topology also impacts the emissions significantly, although not as much as the choice of the material. The largest ratio of emissions between the least efficient topology of adaptive trusses and the most efficient is 2.1. The same ratio for non-adaptive trusses is 3.4. Combining the least efficient material with the least efficient topology causes up to 73.4 times the amount of emissions compared to the most efficient solution in the same circumstances, the corresponding ratio for non-adaptive trusses is 107.2.

The method of increasing the height of the truss to comply with deflection limits with regards to permanent load is problematic. The results where this have been done can not be directly compared to one another as simply as the other results. Increasing the height changes the conditions since a taller truss has the advantage of greater structural height, while it increases the material cost since element lengths are increased. An alternative to this would be to increase the cross-sectional areas manually before the program is run and keep the same height. An other alternative would be to run all the design alternatives within one combination of circumstances with the same height, even if some designs could be successful with smaller height. The ideal solution would be to run an optimisation, finding the height that provides the most efficient solution, within a certain range.



# Bibliography

- [1] Patrick Teuffel. *Adaptive Systems in the Built Environment*. Resource Efficient Structural Engineering Design. Technische Universiteit Eindhoven, 2021.
- [2] Swedish Standards Institute. *SS-EN 1991-1-7:2006*. Swedish Standards Institute, 2008.
- [3] Tord Isaksson, Annika Mårtensson and Sven Thelandersson. *Byggkonstruktion*. Studentlitteratur, 2010.
- [4] Tord Isaksson and Annika Mårtensson. *Byggkonstruktion regel- och formelsamling*. Studentlitteratur, 2016.
- [5] Charlotte Samuelsson. *Varannan svensk har Övervikt eller fetma*. SCB, 2018.
- [6] Gennaro Senatore. *Designing and Prototyping Adaptive Structures - An Energy-Based Approach Beyond Lightweight Design*. Springer International Publishing, 2018.
- [7] Arka P. Reksowardojo, Gennaro Senatore and Ian F.C. Smith. *Design of Structures That Adapt to Loads through Large Shape Changes*. American Society of Civil Engineers, 2020.
- [8] Ahmad Abdul Sater and Oskar Thor. *A Computational Tool for the Design of Prestressed Cable Supported Structures*. Chalmers University of Technology, 2020.
- [9] Arjan Habraken. *Reader Resource Efficient Structural Engineering Design*. Technische Universiteit Eindhoven, 2021.
- [10] Bridge Masters. *Aeroelastic Flutter the Collapse of the Tacoma Narrows Bridge*. Bridge Masters, 2017.
- [11] Dario Gasparini. *The Prestressing of Structures: a Historical Review*. 2006.
- [12] Alexander Sehlström. *Prestress and its Application to Shell, Fabric, and Cable Net Structures*. Chalmers University of Technology, 2021.
- [13] *The Paris Agreement*. The United Nations Climate Change, 2022.
- [14] Per Gunnar Burström and Kjell Nilvér. *Byggnadsmaterial*. 3:2. 2001.
- [15] Per Westlund, Maria Brogren and i.a. *Climate impact of construction processes*. Royal Swedish Academy of Engineering Sciences, 2014.
- [16] Boverket. *Boverkets Klimatdatabas*. Boverket.se, 2022.
- [17] Kim.s Elliot. *Precast Concrete Structures*. Taylor Friends Group, 2016.
- [18] Frits Rooyackers. *Dynamic Control of Adaptive Structures*. Resource Efficient Structural Engineering Design, Technische Universiteit Eindhoven, 2019.
- [19] Träguiden. *Fackverk och underspända konstruktioner*. Svenskt Trä, 2015.
- [20] R Bancila, D Boldus, A Feier, S Hernea and M Malita. *Deflection and Precambering of Steel Beams*. International Scientific Conference CIBV, 2014.

- [21] Alexander Sehlström. *Att Fästa Punkter i Rymden*. WSP Tekniknytt, NAN.
- [22] Linwei He, Qingpeng Li, Matthew Gilbert, Paul Shepher, Catherine Rankine, Pritchard Thomas and Vincenzo Reale. *Optimization-driven conceptual design of truss structures in a parametric modelling environment*. Elsevier, 2022.
- [23] Robin Larsson. *Methodology for Topology and Shape Optimization: Application to a Rear Lower Control Arm*. Chalmers University of Technology, 2016.
- [24] Niels Saabye Ottosen and Han Petersson. *Introduction to the Finite Element Method*. Pearson Education Limited, 1992.
- [25] S.J. Garrett. *Introduction to Actuarial and Financial Mathematical Methods*. Elsevier Inc., 2015.
- [26] Steen Krenk. *Non-linear Modeling and Analysis of Solids and Structures*. Cambridge University Press, 2012.
- [27] SkyCiv. *Pratt Truss*. SkyCiv Cloud Engineering Software, 2021.
- [28] Emma Witman. *What is Python? The popular, scalable programming language, explained*. Business Insider, 2021.
- [29] Charles R Harris. *Array Programming with NumPy*. Business Insider, 2021.
- [30] P-E Austrell, Ola Dahlblom, J Lindemann, A Olsson, K-G Olsson, K Persson, H Petersson, M Ristinmaa and G an Wernberg Sandberg. *Calfem - A Finite Element Toolbox v.3.4*. Lund University, The Division of Structural Mechanics, 2004.
- [31] Wout Sledden. *Adaptive Structures - dynamic active adaptability to minimise material use*. Technische Universiteit Eindhoven, 2014.

# Appendix 1

The results of the analysis performed using the program created in the thesis is presented in the table on the second page of this appendix.

The most favourable result in each set circumstances is highlighted in green, while the least favourable is highlighted in pink. Upwards deflection that does not exceed the maximum allowed deflection in the serviceability limit state is highlighted in orange.

**CO2e** is the carbon dioxide equivalent emissions of the designed adaptive truss.

**Alt. CO2e** is the carbon dioxide equivalent emissions of the corresponding alternative non-adaptive structure.

**Max elong.** is the largest elongation of an individual strut.

**Tot elong.** is the combined elongation of all struts.

**Max def.1** is the deflection caused by permanent load in the inactivated state.

**Max def.2** is the deflection caused by permanent and variable load in the inactivated state.

**Max def.3** is the deflection of permanent and variable load when the structures is activated.

**Max def.4** is the deflection caused by permanent load when the structure is activated.

Circumstances		Design		Material consumption		Activation		Deflections				CO2e savings by Adaptive Function (%)							
Span (m)	Load (PV)/(kN)	SLS limit	Design concept	Material	Amount of frames	h (m)	CO2e (kg)	Alt. CO2e (kg)	Mass (kg)	Max elong. (%)	Tot elong. (mm)	Max def.1 (mm)	Max def.2 (mm)	Max def.3 (mm)	Max def.4 (mm)				
16	1.0/3.0	L/300	Pratt truss	C30	4	1	15.74	29.85	149.37	2.7	6.1	24.95	100	52.75	-18.98	47			
				8	1	22.02	31.36	208.88	1.5	4.5	19.29	77.23	53.01	-8.69	30				
				4	1	528.1	975.86	155.86	2.3	2.9	22.74	91.06	52.8	-13.25	46				
				8	1	681.41	944.42	200.95	1	2.7	16.92	67.71	52.3	-0.11	28				
				4	1	23.89	64.03	226.08	2.7	5.7	34.88	140.04	51.82	-48.78	63				
				8	1	32.49	98.79	308.29	0.8	4.0	38.29	157.74	47.98	-68.57	67				
				4	1	845.36	2082.85	249.29	2.3	4.7	31.12	124.85	51.62	-124.85	59				
				8	1	1154.76	3183.97	340.54	0.7	3.1	34.61	138.86	51.58	-51.33	74				
				4	1.7	9.96	38.85	94.47	1.7	4.8	81.6	15.69	62.88	14.98	-36.77	64			
				8	1.3	16.56	62.17	157.12	1.4	7.6	98.8	15.46	61.91	15.99	-40.23	73			
				4	1.5	389	1543.68	114.71	1.9	5.3	79.5	15.04	60.22	14.57	-35.7	75			
				8	1.1	646.87	2649.79	190.76	1.8	9.4	103.4	15.69	62.79	15.43	-42.33	76			
				4	3.7	11.53	50.04	109.4	0.4	1	37	15.8	63.43	11.2	-35.97	77			
				8	-	-	-	-	Permanent load causes too large deflection	-	-	-	-	-	-	-	-	-	-
				4	2.5	465.55	1864.64	134.64	0.6	1.4	35	15.55	62.39	11.89	-34.38	75			
				64	1.0/6.0	L/1000	Pratt truss	C30	4	1	35.22	66.66	334.17	2.6	6.2	11.16	100.5	53.25	-32.21
8	1	45.91	65.82					435.61	1.5	4.5	8.57	77.27	53.07	-19.19	30				
4	1	1118.72	2124.94					329.76	2.4	5.8	10.78	97.17	53.1	-29.69	47				
8	1	1442.47	2100.07					425.38	1.4	3.8	8.12	73.12	52.89	-15.68	31				
4	1	53.83	143.83					510.76	2.7	5.7	15.47	139.87	51.66	-67.35	63				
8	1	73.9	222.57					701.1	0.8	3.8	17.27	156.09	52.42	-84.3	67				
4	1	1737.48	4550.19					512.38	2.6	5.4	15.17	137.02	53.07	-63.77	62				
8	1	2454.26	7053.94					723.76	0.8	3.4	16.28	147.05	49.57	-79.32	65				
4	1	35.24	223.66					334.32	4.1	14.7	14.7	11.16	100.65	15.15	-80.1	84			
8	1	45.93	216.69					435.77	2.4	13.2	8.57	77.27	15.43	-64.55	79				
4	1	1118.78	7053.27					329.93	5.2	14.3	14.3	10.78	97.17	15.13	-77.68	84			
8	1	1443.17	6840.22					425.59	2.3	12.5	8.12	73.12	15.16	-61.1	79				
4	1	53.85	486.16					510.89	3.3	8.7	15.47	139.87	14.99	-101.97	89				
8	1.2	65.84	621.22					624.67	0.7	4.5	15.88	143.54	12.48	-113.1	89				
4	1	1738.04	15356.7					512.54	3.2	8.6	15.17	137.02	14.38	-100.36	89				
8	1.1	2247.96	21288.69					662.92	0.8	5	15.91	143.69	10.17	-115.38	89				
64	1.0/3.0	L/300	Pratt truss	C30	4	4	251.28	476.99	2384.03	2.7	6.1	100.33	402.1	212.57	-75.45	47			
				8	4	326.56	466.84	3098.32	1.5	4.5	180	77.27	212.55	-34.63	30				
				4	4	7896.84	15055.85	2328.76	2.5	5.9	236	391.79	211.22	-70.18	48				
				8	4	10317.24	14525.87	3042.54	1.4	3.8	152	73.21	293.01	-22.71	29				
				4	4	381.88	1023.23	3623.18	2.7	5.7	228	139.75	208.08	-194.93	63				
				8	4	523.46	1586.15	4966.43	0.8	3.8	152	156.26	212.48	-251.39	67				
				4	4	12456.19	32257.67	3673.31	2.6	5.6	135.25	542.67	207.03	-183.59	61				
				8	4	17224.24	49692.58	5079.4	0.8	3.4	136	148.46	205.61	-236.16	65				
				4	6.7	163.13	638.08	1547.77	1.7	5.8	388.6	62.76	251.57	61.7	-144.02	74			
				8	5.1	265.8	1023.39	2520.24	1.5	8	408	62.78	251.37	63.36	-165.9	74			
				4	6.3	5540.93	22253.38	1634.01	1.9	5.3	333.9	62.39	250.02	58	-150.72	75			
				8	4.7	9041.16	37124.9	2666.22	1.7	8.9	418.3	63.6	254.58	61.61	-170.43	76			
				4	-	-	-	-	Permanent load causes too large deflection	-	-	-	-	-	-	-	-	-	
				8	-	-	-	-	Permanent load causes too large deflection	-	-	-	-	-	-	-	-	-	
				4	14.2	5802.04	25145.49	1711.01	0.4	1	142	63.75	255.81	55.35	-134.94	77			
				64	1.0/6.0	L/1000	Pratt truss	C30	4	4	565.03	1068.05	5360.84	2.7	6.1	44.61	402.39	212.85	-128.65
8	4	733.5	1049.13					6959.18	1.5	4.5	180	34.4	309.97	-76.64	30				
4	4	22796.98	32266.59					6722.79	1.4	4	160	33.01	297.37	-66.21	29				
8	4	17704.93	33365.78					5221.15	2.5	5.9	236	43.63	393.4	-122.06	47				
4	4	860.72	2304.75					8166.18	2.7	5.7	228	61.97	560.12	-269.35	63				
8	4	1177.85	3556.72					11175.06	0.8	3.8	152	69.38	627.05	-336.92	67				
4	4	27410	72415.17					8083.38	2.6	5.6	224	61.47	555.23	-265.15	62				
8	4	38690.02	111744.5					11409.62	0.7	3.5	140	66.09	596.98	-206.97	65				
4	4	565.28	3579.98					5363.15	5.3	14.6	584	44.61	402.39	60.3	-316.8	84			
8	4	733.76	3465.95					6961.68	2.4	13.2	528	34.4	309.97	62.29	-258.12	79			
4	4	17713.43	112665.2					5223.66	5.2	14.3	45.63	393.4	63.24	-310.26	84				
8	4	22806.71	108634.77					6725.66	3.3	12.7	508	33.01	297.37	-247.86	79				
4	4	860.94	7777.91					8168.28	3.3	8.7	348	61.97	560.12	60.56	-407.8	89			
8	4.8	1045.4	9911.19					9918.37	0.7	4.5	216	63.75	576.19	51.93	-452.19	89			
4	4	27418.85	245320.08					8085.77	3.3	8.7	348	61.47	555.23	56.12	-408.27	89			
8	4.7	35512.36	318618.1					9862.74	0.7	4.5	211.5	63.77	576.05	62.75	-441.42	89			