



LUND UNIVERSITY

The variability in Salix BVOC emissions and possible consequences for managed SRC plantations

Karlsson, Tomas

2021

[Link to publication](#)

Citation for published version (APA):

Karlsson, T. (2021). *The variability in Salix BVOC emissions and possible consequences for managed SRC plantations*. [Doctoral Thesis (compilation), Dept of Physical Geography and Ecosystem Science]. Department of Physical Geography and Ecosystem Science, Lund University.

Total number of authors:

1

General rights

Unless other specific re-use rights are stated the following general rights apply:

Copyright and moral rights for the publications made accessible in the public portal are retained by the authors and/or other copyright owners and it is a condition of accessing publications that users recognise and abide by the legal requirements associated with these rights.

- Users may download and print one copy of any publication from the public portal for the purpose of private study or research.
- You may not further distribute the material or use it for any profit-making activity or commercial gain
- You may freely distribute the URL identifying the publication in the public portal

Read more about Creative commons licenses: <https://creativecommons.org/licenses/>

Take down policy

If you believe that this document breaches copyright please contact us providing details, and we will remove access to the work immediately and investigate your claim.

LUND UNIVERSITY

PO Box 117
221 00 Lund
+46 46-222 00 00



The variability in *Salix* BVOC emissions and possible consequences for managed SRC plantations

TOMAS KARLSSON

DEPARTMENT OF PHYSICAL GEOGRAPHY AND ECOSYSTEM SCIENCE | LUND UNIVERSITY





Salix plantation in Skrehalla November 2016. Even though they seem to be sad like weeping willows they are standing tall.

The variability in *Salix* BVOC emissions and possible consequences for managed SRC plantations

The variability in *Salix* BVOC emissions and possible consequences for managed SRC plantations

Tomas Karlsson



LUND
UNIVERSITY

DOCTORAL DISSERTATION

by due permission of the Faculty of Science, Lund University, Sweden.
To be defended at Lundmarksalen, Astronomihuset, Sölvegatan 27, Lund.
Friday 19 November, 2021 at 09:00.

Faculty opponent
Prof. Dr. Robert R. Junker

Organization LUND UNIVERSITY Department of Physical Geography and Ecosystem Science Author: Tomas Karlsson		Document name DOCTORAL DISSERTATION
		Date of issue 2021-11-19
		Sponsoring organization FORMAS
Title and subtitle The variability in <i>Salix</i> BVOC emissions and possible consequences for managed SRC plantations		
Abstract Willow (<i>Salix</i> spp.) trees have been used commercially since the 1980s to produce renewable energy. Some benefits with these trees are that they can clean soil from heavy metals, reduce the risk of nutrient leakage and eutrophication. They could be an alternative to reduce carbon dioxide emissions from fossil fuel, but they are known to emit high rates of biogenic volatile organic compounds (BVOCs). Many thousands of different compounds are included in this group and they can be divided into terpenes, alcohols, alkanes and esters, to mention a few. These compounds are important. For instance, BVOCs help plants to attract pollinators. They serve as a protection to different kinds of stress, e.g., herbivores, heat and pollutions. Once they are released into the atmosphere, they will be involved in many chemical processes. Hydroxyl radicals, which are known to clean the air from pollutions, are depleted by BVOCs leading to increased lifetime of methane. Emissions of BVOCs could also act as precursors for aerosol formation, which in turn might lead to changes in cloud properties and radiative forcing. Photochemical smog like ozone (O ₃) is another result of the reactions in the atmosphere where BVOCs are involved, which impairs regional air quality. The reported range of emission rates from <i>Salix</i> is wide. Details about age, canopy position of leaves and how commercially used <i>Salix</i> varieties differ in their emission potentials are lacking, which lead to large errors if modelled emissions are based on too simple assumptions. Therefore, the aim of the work in this thesis was to investigate how the emissions vary with height, age, variety and during the growing season to get more reliable emission rates that can be used in models to better assess the impacts on the regional air quality. Measurements of aerosol formation were conducted to be able to determine the potential particle production near the <i>Salix</i> site. The outcome from the <i>Salix</i> measurements was then combined with BVOC measurements on spruce to assess how an expansion of <i>Salix</i> plantations could affect the regional air quality if a conversion of the land was shifted into these plantations, e.g., by using more arable and forest land. The study between 2015 and 2016, and the measurements in 2017, showed that <i>Salix</i> mainly emitted isoprene, which peaked during summer. Emissions of monoterpenes (MTs) showed a decreasing trend through the growing season. The BVOC emission rates differed depending on if the leaves were acclimatized to sunlit or shaded conditions, where the sun-adapted leaves emitted twice as much isoprene as the shaded. There was also a significant difference among the studied varieties, where Wilhelm emitted approx. three times more isoprene than Tora. Age influenced the emission rates. The emissions of non-terpenes from younger trees were substantially higher than from the older trees. Emissions of MTs were higher from younger trees compared to older as well. When comparing isoprene emissions, the emission rates from the older trees were almost five times larger than from the younger. Induced emissions of stress-related compounds like hexanal was observed due to an outbreak of <i>Melampsora</i> in 2015. Together with some other compounds, these emissions increased several times. All these results highlight the complexity of BVOC emissions and existing models need to be improved by including parameters like season, age, microclimate adaption and stress to better predict and estimate BVOC emissions. No particle enhancement could be observed from the <i>Salix</i> plantation near the site in 2015. The explanation for this result was the lack of precursors, e.g., MTs. However, spruce trees emitted higher rates of MTs and are probably more prone to generate particles compared to <i>Salix</i> trees. The high isoprene emissions from <i>Salix</i> is more likely to produce O ₃ if sources of anthropogenic NO _x are sufficiently close. An expansion of <i>Salix</i> plantations where spruce forest and traditional agriculture are converted into willow fields would lead to considerably more regional isoprene in the atmosphere. Thus, plantations of <i>Salix</i> should be strategically located to avoid prerequisites to form O ₃ , and preferably the variety Tora should be chosen since it emitted the lowest rates of isoprene.		
Key words: <i>Salix</i> , BVOCs, varieties, age, branch chamber, leaf chamber, GC-MS, aerosols		
Classification system and/or index terms (if any)		
Supplementary bibliographical information		Language: English
ISSN and key title		ISBN (print): 978-91-89187-09-2 ISBN (PDF): 978-91-89187-10-8
Recipient's notes	Number of pages: 174	Price
	Security classification	

I, the undersigned, being the copyright owner of the abstract of the above-mentioned dissertation, hereby grant to all reference sources permission to publish and disseminate the abstract of the above-mentioned dissertation.

Signature

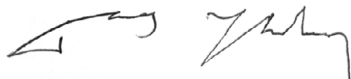

Date 2021-10-11

The variability in *Salix* BVOC emissions and possible consequences for managed SRC plantations

Tomas Karlsson



LUND
UNIVERSITY

Front and back cover photos by Tomas Karlsson

Copyright pp 1–69 (Tomas Karlsson)

Paper 1 © by the Authors (Manuscript unpublished)

Paper 2 © MDPI

Paper 3 © MDPI

Paper 4 © Elsevier

Faculty of Science

Department of Physical Geography and Ecosystem Science

ISBN (print): 978-91-89187-09-2

ISSN (pdf): 978-91-89187-10-8

Printed in Sweden by Media-Tryck, Lund University

Lund 2021



Media-Tryck is a Nordic Swan Ecolabel certified provider of printed material. Read more about our environmental work at www.mediatryck.lu.se

MADE IN SWEDEN 

*Dedicated to Kim and Gunde
(and the rest who R.I.P.,
but I dunno if they care...)*

List of papers

- I. **Karlsson, T.**, Klemedtsson, L., Rinnan, R., Holst, T. (2021). Leaf-scale Study of Biogenic Volatile Organic Compound Emissions from Willow (*Salix* spp.) Short Rotation Coppices Covering Two Seasons. *Accepted for publication in Atmosphere-Basel*.
- II. **Karlsson, T.**, Rinnan, R., Holst, T. (2020). Variability of BVOC Emissions from Commercially Used Willow (*Salix* spp.) Varieties. *Atmosphere-Basel*, 11, 356.
- III. Ahlberg, E., Ausmeel, S., Eriksson, A. C., Holst, T., **Karlsson, T.**, Brune, W. H., Roldin, P., Kristensson, A., Svenningsson, B. (2019). No Particle Mass Enhancement from Induced Atmospheric Ageing at a Rural Site in Northern Europe. *Atmosphere-Basel*, 10, 408.
- IV. van Meeningen, Y., Wang, M., **Karlsson, T.**, Seifert, A., Schurgers, G., Rinnan, R., Holst, T. (2017). Isoprenoid emission variation of Norway spruce across a European latitudinal transect. *Atmospheric Environment*, 170, 45–47.

Contributions

- I. TK contributed to the design of the study, collected all field data, performed all data analysis and led the writing of the manuscript.
- II. TK contributed to the design of the study, collected all field data, performed all data analysis and led the writing of the manuscript.
- III. TK participated in the discussion and the writing of the manuscript.
- IV. TK contributed to the design of the study, collected field data, performed data analysis, participated in the discussion and writing of the manuscript.

Abstract

Willow (*Salix* spp.) trees have been used commercially since the 1980s to produce renewable energy. Some benefits with these trees are that they can clean soil from heavy metals, reduce the risk of nutrient leakage and eutrophication. They could be an alternative to reduce carbon dioxide emissions from fossil fuel, but they are known to emit high rates of biogenic volatile organic compounds (BVOCs). Many thousands of different compounds are included in this group and they can be divided into terpenes, alcohols, alkanes and esters, to mention a few. These compounds are important. For instance, BVOCs help plants to attract pollinators. They serve as a protection to different kinds of stress, e.g., herbivores, heat and pollutions. Once they are released into the atmosphere, they will be involved in many chemical processes. Hydroxyl radicals, which are known to clean the air from pollutions, are depleted by BVOCs leading to increased lifetime of methane. Emissions of BVOCs could also act as precursors for aerosol formation, which in turn might lead to changes in cloud properties and radiative forcing. Photochemical smog like ozone (O_3) is another result of the reactions in the atmosphere where BVOCs are involved, which impairs regional air quality. The reported range of emission rates from *Salix* is wide. Details about age, canopy position of leaves and how commercially used *Salix* varieties differ in their emission potentials are lacking, which lead to large errors if modelled emissions are based on too simple assumptions. Therefore, the aim of the work in this thesis was to investigate how the emissions vary with height, age, variety and during the growing season to get more reliable emission rates that can be used in models to better assess the impacts on the regional air quality. Measurements of aerosol formation were conducted to be able to determine the potential particle production near the *Salix* site. The outcome from the *Salix* measurements was then combined with BVOC measurements on spruce to assess how an expansion of *Salix* plantations could affect the regional air quality if a conversion of the land was shifted into these plantations, e.g., by using more arable and forest land.

The study between 2015 and 2016, and the measurements in 2017, showed that *Salix* mainly emitted isoprene, which peaked during summer. Emissions of monoterpenes (MTs) showed a decreasing trend through the growing season. The BVOC emission rates differed depending on if the leaves were acclimatized to sunlit or shaded conditions, where the sun-adapted leaves emitted twice as much isoprene as the shaded. There was also a significant difference among the studied varieties, where Wilhelm emitted approx. three times more isoprene than Tora. Age

influenced the emission rates. The emissions of non-terpenes from younger trees were substantially higher than from the older trees. Emissions of MTs were higher from younger trees compared to older as well. When comparing isoprene emissions, the emission rates from the older trees were almost five times larger than from the younger. Induced emissions of stress-related compounds like hexanal was observed due to an outbreak of *Melampsora* in 2015. Together with some other compounds, these emissions increased several times. All these results highlight the complexity of BVOC emissions and existing models need to be improved by including parameters like season, age, microclimate adaption and stress to better predict and estimate BVOC emissions.

No particle enhancement could be observed from the *Salix* plantation near the site in 2015. The explanation for this result was the lack of precursors, e.g., MTs. However, spruce trees emitted higher rates of MTs and are probably more prone to generate particles compared to *Salix* trees. The high isoprene emissions from *Salix* is more likely to produce O₃ if sources of anthropogenic NO_x are sufficiently close. An expansion of *Salix* plantations where spruce forest and traditional agriculture are converted into willow fields would lead to considerably more regional isoprene in the atmosphere. Thus, plantations of *Salix* should be strategically located to avoid prerequisites to form O₃, and preferably the variety Tora should be chosen since it emitted the lowest rates of isoprene.

Populärvetenskaplig sammanfattning

Salix (vide eller pil) har använts kommersiellt sedan 1980-talet för att producera förnybar energi. Det finns många fördelar med dessa träd, bland annat kan de rena jord från tungmetaller och minska risken för kväveläckage och övergödning. De kan vara ett alternativ till fossilt bränsle men är också kända för att avge höga flöden av flyktiga organiska föreningar (eng. biogenic volatile organic compounds; BVOCs). Tusentals olika ämnen ingår i denna grupp, vilka kan delas in i terpenener, alkoholer, alkaner och estrar för att nämna några. Dessa ämnen är viktiga. Till exempel så hjälper BVOCs växterna att attrahera pollinerare men kan också skydda växterna emot olika typer av stress såsom växtätare, värme och luftföroreningar. De ingår också i många kemiska processer i atmosfären. Hydroxilradikaler, vilka kallas för luftens renare, bryts ned av BVOCs och detta i sin tur kan leda till ökad livslängd för metan. BVOCs kan också generera aerosoler, vilka påverkar egenskaper hos moln och jordens albedo. Fotokemiska föroreningar som ozon (O_3) är också ett resultat av reaktioner där BVOCs är inblandade och kan leda till försämrad luftkvalitet. Det finns mycket som påverkar BVOC emissionerna och information om ålder, lövposition och hur emissionerna varierar för de olika kommersiella salixklonerna saknas, vilket kan leda till stora fel om modellerade emissioner baseras på alltför enkla antaganden. Syftet med studierna i denna avhandling var således att undersöka hur BVOC emissionerna varierar med lövets position i trädkronan, ålder, för de olika salixsorter samt över växtsäsongen, för att få mer tillförlitliga emissionsvärden som kan användas i modeller för att bättre kunna bedöma påverkan på den regionala luftkvaliteten. Mätningar av aerosolbildning vid en av salixplanteringarna var också en del av studien. Därtill studerades även emissioner av BVOCs från gran för att bedöma hur luftkvaliteten skulle påverkas om mer landyta ändras från till exempel skogs- och åkermark till salixplantage.

Studien mellan 2015 och 2016, och mätningarna från 2017 visade att salix emitterade till största delen isoprene där de högsta värdena inträffade under sommaren. Emissioner av monoterpenener (MTs) avtog allteftersom växtsäsongen fortlöpte. BVOC emissionerna varierade beroende på om löven var acklimatiserade till solljus eller skugga där de solljusanpassade löven emitterade dubbelt så mycket isopren. Det fanns också en betydande skillnad mellan de olika salixsorterna och Wilhelm emitterade ungefär tre gånger mer isopren än Tora. Åldern påverkade också emissionerna. Både emissioner av icke-terpenener och MTs var högre från de yngre träden medan isopren var nästan fem gånger så hög från de äldre träden. Stressinducerade emissioner av ämnen som hexanal inträffade under ett utbrott av

svampen *Melampsora* 2015 och tillsammans med några andra ämnen så ökade emissionerna för dessa flertalet gånger. Alla dessa resultat understryker svårigheten med att simulera emissioner av BVOCs och nuvarande modeller behöver förbättras genom att inkludera parametrar som tid på säsongen, ålder, anpassning till rådande mikroklimat och stress för att bättre förutse och beräkna BVOC emissioner.

Ingen partikelökning kunde observeras vid salixplanteringen 2015. Förklaringen till detta var för låga halter av bland annat MTs. Däremot så emitterade gran högre halter av MTs och är förmodligen mer benägna att generera partiklar i förhållande till salix. Det är mer troligt att salix istället kan ge upphov till O₃ på grund av de höga emissionerna av isopren, om utsläpp av NO_x är tillräckligt nära. Att ändra landytans markanvändning från granskog och traditionellt jordbruk till salixplantage skulle därför kunna ge upphov till betydande högre halter av isopren lokalt. Därför behöver dessa salixplanteringar vara strategiskt placerade så att förutsättningar till O₃ produktion undviks, och sorten Tora bör därmed väljas eftersom denna emitterade de lägsta halterna av isopren.

Table of contents

List of papers	9
Contributions.....	9
Abstract	11
Populärvetenskaplig sammanfattning	13
Table of contents	15
Introduction	17
<i>Salix</i> trees	17
BVOCs	18
Why plants emit BVOCs.....	20
Production and emission of BVOCs	20
BVOCs influence on air chemistry	22
BVOC emission and climate feedback.....	23
Aims and objectives	24
Material and methods	25
Study sites	25
<i>Salix</i> sites (Paper I–III).....	25
Spruce sites (Paper IV).....	27
Plant material	28
Equipment	29
Setup of branch chamber	29
Setup of leaf chamber.....	30
Sampling of BVOCs.....	31
PTR-MS measurements.....	31
Particle measurements	32
Field measurements on <i>Salix</i>	33
Analysis of BVOC chamber measurements from <i>Salix</i>	34
GC-MS analysis.....	34
Calculations of BVOC emissions.....	34

Results and discussion	37
Phenological and genetical influences on BVOC emissions from <i>Salix</i> (Papers I and II).....	37
Comparison between different heights and light conditions (Papers I and IV)	42
Impact of age on BVOC emissions (Paper I and II).....	44
LUCC and impact on air quality from <i>Salix</i> (Paper I–IV)	46
Conclusions and outlook	49
Acknowledgments	53
References	55

Introduction

Salix trees

Because of the rapid increase of greenhouse gases (GHGs), i.e., carbon dioxide (CO₂), methane (CH₄) and nitrous oxide (N₂O), and temperature in the atmosphere (IPCC, 2014; IPCC, 2018, IPCC, 2021), mitigation strategies have been suggested to decrease the use of fossil fuel and to limit the global average temperature increase below 2°C (European Commission, 2014; Paris Agreement, 2015). In the long run, a reduction between 80–95% of GHG emissions in 2050 compared to 1990 will be necessary by the developed countries (Gupta et al., 2007; European Commission, 2014). Additionally, Sweden has the goal to achieve zero net emissions of GHGs by the year 2045 (Swedish EPA, 2019; Bonde et al., 2020). To solve the future energy demand, more focus has been put on renewable energy and one way to meet these goals could be to produce energy from plant biomass. The benefit of using plants is that they do not add any extra carbon (C) to the atmosphere compared to fossil fuel, since the C released from plants in combustion is basically the same amount that is taken up by the plants. By using biorefineries, the shift toward a more C neutral society could be achieved (Ragauskas et al., 2006).

Perennial biomass crops, also known as short rotation coppices (SRCs), are suitable for producing renewable energy and can be grown directly on agricultural land, i.e., short rotation plantations (SRPs). The SRCs do not require as much management as annually harvested crops, and trees might be one of the least nutrient-intensive bioenergy, resulting in less emitted GHGs compared to using annual crops as bioenergy (Kägi et al., 2008; Hillier et al., 2009). One suitable tree species for this purpose is willow (*Salix* spp.). However, even if it has been shown that using willow as a renewable energy source can reduce CO₂ emission compared to fossil fuel (Kimming et al., 2011; Therasme et al., 2021), it is still not clear how it will influence the concentrations of GHGs in the atmosphere. High emissions of CH₄ and N₂O from the SRPs could compensate for the uptake of CO₂ (Zenone et al., 2016), but more life cycle assessment (LCA) studies are needed, which cover the whole growing life span of the plantations.

Together with *Populus* (poplars, cottonwoods and aspens), *Salix* (willows, sallows and osiers) belong to the Salicaceae family. It is relatively easy to propagate and hybridize these plants, which have made them suitable as bioenergy crops (Isebrands and Richardson, 2014). They were probably already used more than

10 000 years ago in the Middle East for cooking, heating and construction (Stettler, 2009). *Salix* has been grown in Sweden since the early 1970s and was first used to produce new plant material for the paper industry (Hollsten et al., 2013). The research has continued since then to establish new species with desired features and since the 1980s, willow trees have been intensively used as energy crop (Lindegaard et al., 2016). The earlier *Salix* varieties used in Sweden for bioenergy production were clones from the European willow species *Salix viminalis*. Unfortunately, these older clones were susceptible to rust and new hybrids have been developed using *Salix* from, e.g., Siberia (*Salix schwerinii*) to create new varieties with improved resistance to rust and better yield (Åhman and Larsson, 1999). Currently, *Salix* plantations are growing on crop land and the majority of the plantations in Sweden are mostly located in the southern part, e.g., in Scania or near the lakes Mälaren and Hjälmaren. The current land use for SRPs in Sweden is around 10 000 ha, whereof *Salix* comprises approx. 50%, but the potential has been estimated to be between 200 000 and 300 000 ha (Fredga et al., 2008).

Managed *Salix* trees grow between 3 and 5 years before they are harvested. Compared to annual crops, *Salix* trees do not need as much management even though some fertilization is common to increase the plant growth (Kägi et al., 2008). For instance, the ratio between how much energy is put in and how much is gained is only 5–6% for *Salix*, while it is 10–17% for annual crops (SOU 2007:36). When it comes to C uptake, *Salix* trees assimilate approx. 5.5 times more C than normally managed spruce forest (Grelle et al., 2007). There are many environmental advantages with growing *Salix* (Kägi et al., 2008). Studies have shown that *Salix* could be beneficial to enhance biodiversity in arable environments (Baum et al., 2009; Karp et al., 2009). *Salix* has the ability to clean the soil by taking up heavy metals, e.g., cadmium and zinc (Landberg and Greger, 1996; Meers et al., 2007; Baum et al., 2009; Mleczek et al., 2010). *Salix* plantations can also be used to clean effluents from nitrogen and phosphorus after application of sludge and waste water treatments (SOU 2007:36; Fredga et al., 2008; McCracken and Johnston, 2015). The increase in soil C stock, mulch, and reduced risk of nutrient leakage and erosion are other positive effects on the environment with *Salix* compared to annual crops (SOU 2007:36; Fredga et al., 2008). However, like other broad leaf trees, such as oaks, aspens and eucalypti, *Salix* species have shown to be high emitters of biogenic volatile organic compounds (BVOCs) (Hakola et al., 1998; Isebrands et al., 1999; Kesselmeier and Staudt 1999; Owen and Hewitt, 2000).

BVOCs

Ever since Went (1960) stated the hypothesis about blue haze originating from plant emitted terpenes, more attention and efforts have been carried out to explain this phenomenon, leading to new discoveries and eventually to an increased

understanding of a group of compounds called volatile organic compounds (VOCs). They were believed to be involved in photochemical smog formation in the 1950s (Haagen-Smit, 1952) and their production and emission by plants were also discussed by Sanadze et al. (1956). These molecules can either come from natural sources, referred to as BVOCs, or from human activities, i.e., anthropogenic volatile organic compounds (AVOCs). Attempts have been made to estimate the global emissions of VOCs, where the natural emission is estimated to be more than 10^{15} g C a year, which is many times higher than the emissions of AVOCs (Hough and Johnson, 1991; Müller, 1992; Guenther et al., 1995; Guenther, 2002; Peñuelas and Llusà 2003; Guenther et al., 2012).

There exists no clear definition of VOCs but according to the Environmental Protection Agency (EPA) in the US, they are defined as any compound of C that participate in atmospheric photochemical reactions except carbon monoxide, CO₂, carbonic acid, metallic carbides, carbonates, and ammonium carbonate. This definition also excludes several other compounds such as CH₄, which lead to the establishment of the abbreviation NMHCs (nonmethane hydrocarbons) or NMVOCs (nonmethane VOCs) (Kesselmeier and Staudt, 1999). Attempts have been made to state a clearer definition, which resulted in that VOCs are those organic compounds with a vapour pressure >10 Pa at 25°C, a boiling point up to 260°C at atmospheric pressure and consist of not more than 15 C atoms (Williams and Koppmann, 2007). The definition has become blurred, new groups or compounds have been included and now there exist VOCs with far more than 15 C atoms.

In living organisms, more than 60 000 terpenoids have been described and plants emit more than 30 000 different BVOCs (Niinemets et al., 2004; Xie et al., 2012; Niinemets and Monson, 2013). The compounds can be divided into different groups depending on their chemical structure and characteristics. Terpenes (e.g., hemiterpenes, monoterpenes (MTs) and sesquiterpenes (SQTs)) share the same carbon and hydrogen structure, which is built up by multiples of C₅H₈. Thus, hemiterpenes contain one C₅H₈ chain, MTs contain two (i.e., C₁₀H₁₆) and so on. The group terpenes are sometimes interchangeable with terpenoids (also known as isoprenoids), although the latter contains additional functional groups like oxygen. Other groups are alkanes, alkenes, carbonyls, alcohols, ester, ethers and acids (Kesselmeier and Staudt, 1999). Green leaves volatiles (GLVs) is another important group, which can induce plant defense and help plants against herbivores and pathogens (Ameye et al., 2018). They are released when plants are hurt and damaged and originate from the lipoxygenase (LOX) pathway (Hatanaka et al., 1993; Laothawornkitkul et al., 2009; Ameye et al., 2018). Everyone that has mowed the lawn has got acquainted with this certain smell from GLVs (Olofsson et al., 2003; Watkins et al., 2006; Dombrowski et al., 2019). One of the most important and common compounds is isoprene, which belong to the group hemiterpenes. The production and emission of isoprene was first discussed by Sanadze (1956) and has been estimated to comprise around 50% or more of all emitted BVOCs (approx. 500

$\times 10^{12}$ g C year⁻¹) followed by methanol (approx. 100×10^{12} g C year⁻¹), by using the MEGAN model (Guenther et al., 2006; Guenther et al., 2012).

Why plants emit BVOCs

The reasons why plants emit BVOCs are manifold but simply put, the main reason is to help the plants to survive and reproduce themselves. These compounds serve as communication between plant-plant and plant-animal, and play critical roles in plant defense (Yuan et al., 2009). For instance, BVOCs can attract pollinators (Peñuelas and Staudt, 2010). They act as protection against biotic stress (e.g. insects and pathogens), either by direct defense (repel or deter herbivores) or by indirectly induced defense (attract parasitoids or predators of herbivores) (Dicke and Vet, 1999; Llusià and Peñuelas, 2001; Dicke et al., 2003a; Dicke et al., 2003b). They also act as protection against abiotic stress (e.g., extreme temperature, drought, intense sunlight, mechanical damage and pollutants) (Beauchamp et al., 2005; Capitani et al., 2009; Vickers et al., 2009; Loreto and Schnitzler, 2010; Brillì et al., 2012; Copolovici et al., 2012). The major part of the photosynthesized C is used in primary production and only a few percent is reemitted back to the atmosphere as, e.g., isoprene (Kesselmeier et al., 2002; Bracho-Nunez et al., 2013). However, the emission of stress-induced BVOCs can result in significantly larger fraction of reemitted C (Sharkey and Loreto, 1993; Sharkey et al., 1996).

Production and emission of BVOCs

The production of the different BVOCs in plants are complex and since it is related to secondary metabolism, the plants need to balance the investment in C between primary production, i.e., biomass, and the production of BVOCs (Paiva, 2000). The pathways are interlinked and not fully understood. In general, it starts with photosynthesis and the Calvin cycle where C atoms later on are distributed to different pathways, depending on which kind of compound that is produced in the end (Laothawornkitkul et al., 2009). There is also indication that starch and respiratory CO₂ could be an alternative C source to isoprene formation besides recently photosynthesized CO₂ (Loreto et al., 2004; Schnitzler et al., 2004). Isoprene, together with the other terpenes, share some of the similar production pathways, i.e., isoprenoid pathways. They are produced from the same substrate, isopentenyl pyrophosphate (IPP) and its isomer dimethylallyl diphosphate (DMAPP) (Vickers et al., 2009). Two different isoprenoid pathways have been found that produce IPP and DMAPP; the cytosolic mevalonic acid pathway (MVA) and the plastidic 2-C-methyl-D-erythritol 4-phosphate pathway/1-deoxy-D-

xylulose 5-phosphate pathway (MEP/DOXP) (Lichtenthaler et al., 1999; Rohmer 1999; Lange et al., 2000; Humphrey and Beale, 2006). The MEP/DOXP pathway is responsible for producing isoprene, MTs, diterpenes and other higher orders of terpenes, while homoterpenes, SQTs and triterpenes are produced through the MVA pathway (Vickers et al., 2009) (Figure 1). Compounds that are released directly after they are produced, such as isoprene, are emitted from de novo synthesis. Other compounds are stored in pools, e.g., in resin ducts and glandular trichomes (Kesselmeier and Staudt, 1999), and emitted when they are needed.

The emissions of BVOCs can be divided into two categories; constitutive and induced emissions. The former is considered as normal state emissions, which continuously occurs to build up a barrier against herbivore attacks (Paiva 2000; Walling, 2000). Constitutive production and emissions of BVOCs are sensitive and influenced by different stress factors, such as temperature, light, herbivores and pathogens (Ninemetts et al., 2004; Loreto et al., 2006; Loreto and Schnitzler, 2010, Joó et al., 2011). Induced emissions, on the other hand, are a response to a direct impact from, e.g., herbivores causing wounds on the leaf tissue (Loreto and Schnitzler, 2010; Possell and Loreto, 2013).

Instantaneous emission rates of BVOCs are mainly controlled by temperature and sunlight. Thus, the two of the most commonly used models that describe the emissions for many terpenes are based on the temperature-dependent algorithm (used for, e.g., for MTs and SQTs that are stored in pools) or the light- and temperature-dependent algorithm (used for, e.g., isoprene) (Guenther et al., 1991; Guenther et al., 1993; Helmig et al., 2007). But these algorithms poorly reflect long-term effects (e.g., phenological changes) and they also do not include stress-induced emissions of BVOCs. The algorithms also rely on emission potentials, which varies a lot among and within species (Kesselmeier and Staudt, 1999). This diversity points out the need for accurate and representative emission potentials when scaling up the BVOC emissions.

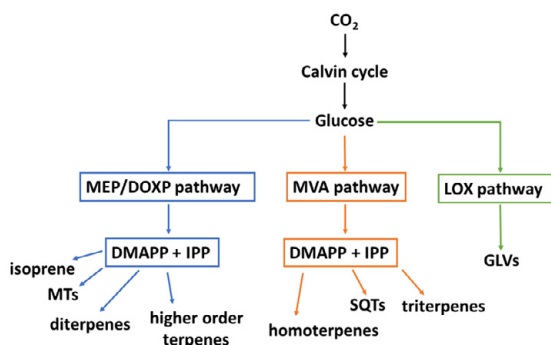

Figure 1. A simplified description of the production pathways for terpenes (blue and orange arrows) and green leaf volatiles (GLVs, green arrows). Redrawn from Laothawornkitkul et al. (2009) and Vickers et al. (2009).

BVOCs influence on air chemistry

Even though the concentration of BVOCs in the atmosphere is much lower than, e.g., CO_2 , they play an important role for atmospheric chemistry and oxidation processes since they are very reactive (Monks et al., 2010).

The most crucial initiators for oxidation reactions in atmosphere are hydroxyl (OH) radicals produced by photochemical processes (Olofsson et al., 2005). Many BVOCs react with OH radicals (Atkinson and Arey, 2003), but depending on which compound that is involved in the reaction, both production and consumption of OH are possible. For instance, isoprene and MTs are possible consumers of OH whilst alkenes could be a source (Paulson and Orlando, 1996; Atkinson, 1997; Folberth et al., 2005; Olofsson et al., 2005). When OH radicals are consumed, they will not be able to react with CH_4 and consequently, a depletion of these radicals will lead to a prolonged atmospheric lifetime of CH_4 and increased global warming (Folberth et al., 2006; Kaplan et al., 2006; Arneth et al., 2008).

Oxidation of BVOCs can also lead to production of ozone (O_3) and peroxyacetyl nitrates (PANs) in the troposphere (Roselle et al., 1991; Ryerson et al., 2001; Kleinman et al., 2002; Atkinson and Arey, 2003; Watson et al., 2006; Pike and Young, 2009). High concentrations of O_3 and PAN can be harmful for humans and vegetation (Lovelock, 1977; Temple and Taylor, 1983; Sakaki, 1998; Vyskocil et al., 1998; Fumigalli et al., 2001; Ashmore, 2005; Sun et al., 2014; Emberson et al., 2018). The prevailing conditions in the atmosphere determine if there will be a production or a depletion of O_3 . The chemical reaction that produces O_3 occurs via formation of nitrogen dioxide (NO_2) (Kleinman et al., 2002; Atkinson and Arey, 2003). If the concentrations of NO_x (NO and NO_2) are sufficiently high, then this process will lead to enhanced levels of tropospheric O_3 (Ryerson et al., 2001; Kleinman et al., 2002; Calfapietra et al., 2013). On the other hand, when NO_x concentrations are too low, O_3 will react directly with BVOCs and a depletion of O_3 will instead occur (Fehsenfeld et al., 1992; Laothawornkitkul et al., 2009). Since O_3 is a GHG, increased concentrations of O_3 will enhance global warming. Increased concentrations of O_3 could also result in a reduced plant productivity and indirectly lead to more CO_2 in the atmosphere and to an increased radiative forcing (Sitch et al., 2007; Wittig et al., 2009).

Another important mechanism that BVOCs are responsible for is the formation of secondary organic aerosols (SOAs). Aerosols, which are airborne particles suspended in the atmosphere, affect the climate by scattering and absorbing radiation from the sun (Kulmala et al., 2004). These particles are produced in two different ways. The first one occurs via gas-phase oxidation products, which condensate onto pre-existing particles. The other alternative is via nucleation, or new particle formation. To be able to quantify the SOA formation, these processes need to be modelled and one way to do it is to divide them into the following steps: gaseous emissions, gas-phase chemistry, nucleation/gas-particle partitioning and aerosol-phase/aqueous phase chemistry/cloud processing (Kanakidou et al., 2005).

Many studies have shown that oxidation products from isoprene, MTs and SQTs act as precursors for condensable products that are required to create SOAs (Pandis et al., 1991; Hoffmann et al., 1997; O'Dowd et al., 2002; Clayes et al., 2004; Kulmala et al., 2004; VanReken et al., 2006; Ehn et al., 2014). Aerosols in turn, can lead to enhanced cloud condensation nuclei (CCN) production (O'Dowd et al., 2002; Paasonen et al., 2013; Ehn et al., 2014) and have an impact on cloud formation and precipitation, and thereby change the properties of the clouds (Kulmala et al., 2004; Holzinger et al., 2005; Spracklen et al., 2008; Paasonen et al., 2013). More SOAs and CCN will consequently lead to an increased albedo, which in turn is believed to counteract global warming (Kulmala et al., 2004; Peñuelas and Staudt 2010; Boucher et al., 2013).

Although the overall agreement is that SOAs and CCN cool the earth, all the mechanisms behind these processes are complicated and not completely understood (Boucher et al., 2013; Rosenfeld et al., 2014; Fan et al., 2016; Seinfeld et al., 2016). This uncertainty is represented by the large error bar in the estimation of the radiative forcing from aerosols by IPCC (Stocker et al., 2013). In addition, atmospheric aerosols are considered to impair human health and together with other pollutions, they cause several millions premature deaths globally (Pope and Dockery, 2006; Kuehn, 2014; Landrigan et al., 2017).

BVOC emission and climate feedback

The global warming during the last 30 years could be responsible of 10% additional BVOC emissions (Peñuelas and Llusia, 2003). Increased global temperatures will likely result in longer plant growing season (Peñuelas and Filella, 2001). Phenological events such as leafing, flowering and senescence are plant processes that will be affected by a changed climate and could contribute to changed BVOC emissions. A temperature increase between 2 and 3°C could generate additional 30–45% BVOC emissions globally (Peñuelas and Llusia, 2003), but these estimations are based on models with fixed emission factors and could overestimate regional emissions. The net effect of BVOC emissions on the climate is difficult to quantify because of all the complex feedback processes. Elevated atmospheric concentrations of CO₂ and extreme weather events add complexity to the emissions but need to be considered to better estimate future BVOC emission scenarios (Llusia and Peñuelas, 1998; Staudt et al., 2008; Taylor et al., 2008; Peñuelas et al., 2009). A simplified description of how increased BVOC emissions could affect the global warming can be seen in Figure 2, where depletion of OH and production of O₃ (in high NO_x areas) are believed to enhance global warming, whereas increased consumption of O₃ (in low NO_x areas), production of SOAs and CCN may reduce global warming.

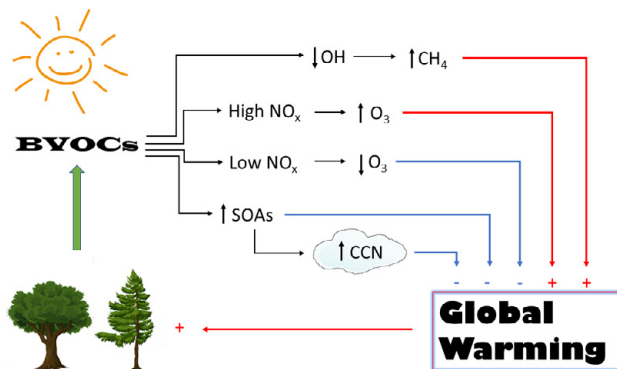

Figure 2. Schematic picture on how emission of BVOCs are coupled to climate warming by processes in the atmosphere. Redrawn from Laothawornkitkul et al. (2009) and Peñuelas and Staudt, 2010.

Aims and objectives

While a large expansion of *Salix* plantations may be good for mitigating climate change, local air quality could be negatively affected. Due to the wide range of published emission potentials among *Salix* species, new reliable emission potentials are needed to better estimate the emission on an ecosystem scale. The newer *Salix* varieties that are used commercially might differ in their emission rates and compound mixture compared to the reported older species.

The overarching aim of the work presented in this thesis was to study some of the important factors that influence the emission rates from managed *Salix* trees. These results are then combined with measurements on aerosol formation near a *Salix* plantation, and with BVOC emissions from spruce, to assess what the possible outcome could be for the regional air quality if land use and cover change (LUCC) shifts the current land use into SRPs with *Salix* in areas like Sweden.

The specific objectives were:

- To study and quantify how seasonality and different varieties influence BVOC emissions from commercial *Salix* trees (Paper I and II).
- To study and quantify how position within canopy height influences the BVOC emissions (Paper I and IV).
- To study and quantify how the age of the *Salix* trees influences the BVOC emissions (Paper I and II).
- To investigate how BVOC emissions from *Salix* plantations could impact the local air quality compared to traditional agriculture and spruce forest (Paper I–IV).

Material and methods

Study sites

The study sites can be divided into two categories, the first one contains sites that have been subjected to BVOC measurements at *Salix* plantations and these are located in Sweden (Skrehalla and Billeberga). The second has been related to BVOC measurements from spruce and these sites were found both in Sweden (Hyltemossa, Skogaryd and Norunda), and in other parts of Europe (Ljubljana (Slovenia), Grafrath (Germany), Taastrup (Denmark) and Piikkiö (Finland)), whereof these four latter sites were a part of the International Phenological Garden (IPG).

***Salix* sites (Paper I–III)**

Skrehalla

Most of the *Salix* measurements were done in Skrehalla, which is located in the municipality of Grästorps and about 80 km north-east of Gothenburg. Two plots were chosen at this site (plot 1 (P1), 58°16'55'' N 12°46'20'' E and plot 2 (P2), 58°17'09'' N 12°45'31'' E) (Figure 3). Mean annual temperature was 6.1°C (1961–1990) and annual precipitation was 683 mm (1961–1990) (Karlsson et al., 2020). An older variety of *S. viminalis* was established in 1994 on P1 but was replaced with a new one called Wilhelm in 2017, which means that measurements in 2015 (Paper I and III) was conducted on two older varieties in their third growing season after the last harvest, and measurements in 2017 (Paper II) was conducted on Wilhelm (first growing season). On P2, a variety called Tora was planted in 2003 and in 2016 they had their fourth growing season after the last harvest. The area of P1 was approx. 6 ha and P2 was around 5 ha. All trees on P1 and P2 were planted in double rows, separated with 1.25 m. The distance between the rows in each double row was 0.75 m and the trees were planted with 0.4 m intervals in the rows.

Billeberga

This site is located approx. 300 km south of Skrehalla, outside a community called Billeberga in the municipality of Svalöv. Two plots were studied at this location (plot 3 (P3), 55°52'32.9'' N 13°1'18.2'' E and plot 4 (P4), 55°52'11.7'' N 13°1'33.3'' E) (Figure 3). *Salix* trees growing here were used in field trails for

producing new commercial varieties suitable for biomass production. These field trials were run by a commercial company (European Willow Breeding AB). Mean annual temperature and precipitation for this site were 7.7°C (1961–1990) and 687 mm (1961–1990), respectively (Karlsson et al., 2020). Several different *Salix* varieties were growing on P3 and P4 but the ones chosen to be studied were Wilhelm, Tora, Inger and Ester. On P3, the varieties were planted in 2014 and cut down before growing season in 2016, which implies that these trees had their second growing season in 2017 (Paper II). The varieties on P4 were planted in 2017 and had their first growing season when measurements were done in 2017. Each variety on P3 and P4 was growing in approx. 5 m long rows and the rows were separated by approx. 0.7 m. In the rows, trees had been planted at 0.5 m intervals.



Figure 3. The two sites (black circles) in Sweden represent Skrehalla (P1 and P2) and Billeberga (P3 and P4) where measurements on *Salix* trees were performed. The picture is taken and modified from Lantmäteriet.

Spruce sites (Paper IV)

Hyltemossa

Hyltemossa is a site run by the Integrated Carbon Observation System (ICOS) in Sweden (<http://www.icos-sweden.se/hyltemossa>) and is located in the southern part of Sweden (56°06' N 13°25' E) (Figure 4). This site is a forest dominated by Norway spruce (*Picea abies*) but it also contains small amounts of other species such as birch (*Betula* sp.) and Scots pine (*Pinus sylvestris*). When the BVOC measurements were done here in 2016, the age of the trees was around 30 years. Annual mean temperature and precipitation (1961–1990) for the area was 6.9°C and 831 mm, respectively (Alexandersson and Eggertsson Karlström, 2000).

Skogaryd

Skogaryd research site is a part of the Swedish Infrastructure for Ecosystem Science (SITES), established in 2013 (<https://www.gu.se/en/earth-sciences/skogaryd-research-catchment-0>). It is located in the south-western part of Sweden (58°23' N 12°09' E) and about 40 km west of Skrehalla (Figure 4). The measurements were done on subsite F (Forest on mineral soils) according to the classification on the webpage. The forest contained mainly coniferous trees, dominated by Norway spruce and Scots Pine with a stand age of approx. 50 years old trees. The mean annual temperature was 6.2°C and mean annual precipitation was 709 mm (1961–1990) (Alexandersson and Eggertsson Karlström, 2000).

Norunda

The location of Norunda (60°05' N 17°29' E) is around 30 km north of Uppsala (Figure 4). It is part of the ICOS network in Sweden (<http://www.icos-sweden.se/norunda>). It was established in 1994 and the forest is dominated by Norway spruce and Scots pine but with some deciduous trees like birch. The age of the trees varies mostly between 60 and 110 years. Annual temperature and precipitation were 5.6°C and 544 mm (1961–1990), respectively.

IPG sites

The four remaining sites were located in Ljubljana (Slovenia, 46°04' N 14°30' E), Grafrath (Germany, 48°18' N 11°17' E), Taastrup (Denmark, 55°40' N 12°18' E) and Piikkiö (Finland, 60°23' N 22°30' E) (Figure 4). The advantage with these IPG sites is that they contain clones of different species, which makes it possible to exclude the genetic influence and consequently, study the impact of climate change and environmental adaption in the species (Chmielewski et al., 2013). The sites were established more than 50 years ago. Since they are located in a wide latitudinal range, mean annual temperature and precipitation varied from 5.9–10.9°C and 583–1362 mm, respectively (van Meeningen et al., 2017).



Figure 4. The black circles mark the Norway spruce sites where BVOC measurements were done 2014–2016. Image from van Meening et al. (2017).

Plant material

The older varieties used for biomass production originated from species such as *S. viminalis* and the names usually contained letters followed by digits. Since commercial willow varieties are easy to breed, many new clones have been propagated the last decades. A short description of the four varieties studied in 2016 and 2017 is given below. The family tree for these varieties can be seen in Figure 5.

Tora was produced in 1989 from the clone L 79069 (*S. schwerinii* originating from Siberia) and the variety Orm, and is a female hybrid. Tora is one of the most successful varieties growing in northern latitudes since it is resistance to frost and rust.

Inger was produced in 1994 and is a female hybrid cross between the clone SW 911096 (*S. triandra* originating from Siberia) and the variety Jorr. Inger is suitable for mild or warm climates with normal water supply.

Wilhelm is a male hybrid and a cross between the varieties Sherwood and Björn. Wilhelm was produced in 2011. The biomass productivity from Wilhelm is somewhere between Tora and Inger.

Ester is a female hybrid and was produced in 2012 from the variety Linnéa and a clone of “Shrubby willow” (*S. miyabeana*). The yield from Ester is similar to Inger and it is suited for dry and hot climates. Among these four varieties, Ester is the only one that is almost completely free from leaf beetle attacks.

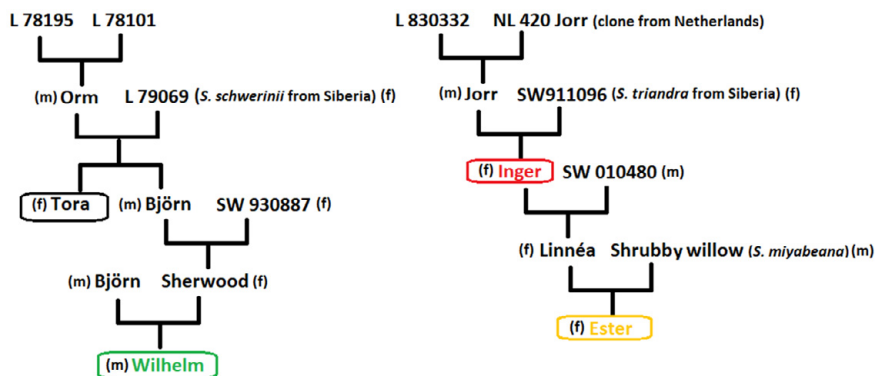

Figure 5. Family tree for the produced *Salix* varieties studied on P1 (Wilhelm), P2 (Tora) and P3–P4 (Tora, Inger, Wilhelm and Ester). Letters in parentheses represent gender; male (m) or female (f).

Equipment

Measuring volatile organic compounds can be done in different ways. One common approach is to use vegetation enclosures (e.g., bags or chambers). From these enclosures, samples can be taken by using adsorbent cartridges, which are later on analyzed with gas chromatography mass spectrometry (GC-MS). This method has high spatial resolution but lacking in the temporal resolution. Instead, using a technique based on proton transfer reaction mass spectrometry (PTR-MS) makes it possible to directly monitor and observe the emissions in the field. Additionally, when using vegetation enclosures, two techniques can be used, static (no purge flow) or dynamic (flow-through). In case of static, CO₂ concentration together with temperature could change dramatically resulting in non-realistic conditions, making this technique less preferably (Ortega and Helmig, 2008). The dynamic enclosure makes it easier to keep the conditions closer to ambient and this technique has been used throughout all manual measurements between 2015 and 2017. Two types of chambers were used, a leaf chamber and branch chamber.

Setup of branch chamber

The branch chamber had a cylindrical shape. It was made of stainless steel, Teflon (PFA) and covered with a transparent PFA film (Figure 6A). The volume was approx. 13 l. The day before the measurements started, the tip of the tree branch was inserted into the chamber. The chamber was closed and flushed one hour before the measurements started. Purge air was continuously flowing into the chamber. The purge air passed through a hydrocarbon trap (Alltech, Associates Inc., US), containing activated carbon and MnO₂-coated copper nets, providing BVOC- and

O₃-free air entering the chamber. Air temperature (T, °C) and relative humidity (RH) were measured inside (chamber T and RH denoted as T_C and RH_C) and outside of the chamber (CS215, Campbell Scientific, UT, US). Measurements of photosynthetically active radiation (PAR, μmol m⁻² s⁻¹) was measured close to the chamber (PAR_C) and at canopy level (Li-190, LI-COR, NE, US) and recorded together with T and RH on a data logger (CR1000, Campbell Scientific, UT, US). Only one branch chamber was used in 2015, but from June–October in 2016, two identical branch chambers were used in parallel at different heights.

Setup of leaf chamber

The leaf chamber system consisted of two parts, a portable photosynthesis system (LI-6400XT, LI-COR, NE, US) and a leaf chamber with a LED source (6400-02B) (Figure 6B). One advantage with this system is that it is possible to control PAR, T, RH and CO₂ while doing measurements. To control RH, water vapor is removed by using Drierite. Soda lime, a mixture of calcium oxide and sodium hydroxide, was used to remove CO₂. Using cartridges of CO₂ then made it possible to regulate concentration of incoming CO₂ into the chamber. Purge air into the leaf chamber passed through a similar hydrocarbon trap as in the branch chamber setup. The leaf chamber system was modified to be able to measure BVOCs by adding an extra outlet between the leaf chamber and the infra-red gas analyzer (IRGA). The maximum leaf area that is possible to measure with the leaf chamber is 6 cm² (2x3 cm²). While doing measurements, ambient conditions were maintained inside the chamber of CO₂ (400 ppm), T (20–25°C) and RH (30–70%). Emissions of BVOCs were measured at different light levels and changed in the following order 0, 150, 300, 450, 600, 1000 and 1500 μmol m⁻² s⁻¹. Along with BVOC emissions, net assimilation (A, μmol CO₂ m⁻² s⁻¹), transpiration (Tr, mmol H₂O m⁻² s⁻¹) and stomatal conductance (g_s, mol H₂O m⁻² s⁻¹) were measured.

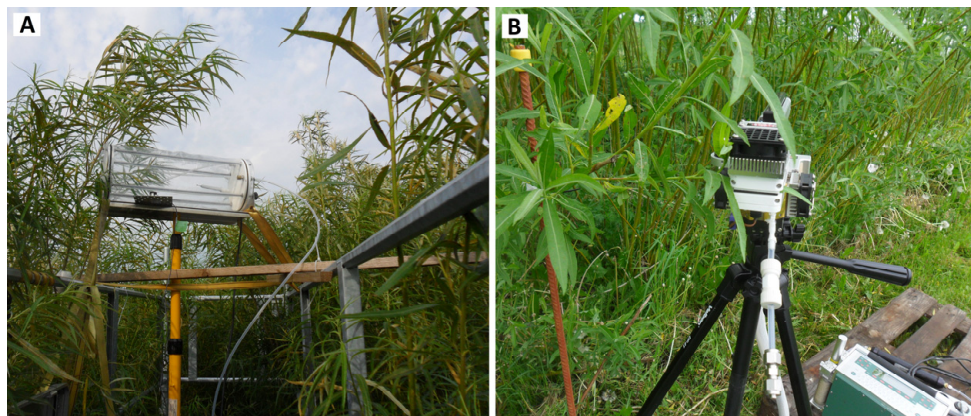

Figure 6. A) Setup of branch chamber measurements on P1 in Skrehalla 2015. B) Setup of leaf chamber measurements on P3 in Billeberga 2017.

Sampling of BVOCs

All samples were taken by using a flow-controlled pump (Pocket Pump, SKC Ltd., Dorset, UK). Sample air was pulled from the chambers and through an adsorbent cartridge containing Tenax TA (a porous organic polymer) and Carbograph 1TD (graphitized black carbon) (Markes International Ltd., Mid Glamorgan, UK) during 20 min with a flow rate of 0.2 l min^{-1} . Samples were taken during daytime (8:00–18:00) with approx. one-hour intervals. In the case of the leaf chamber, measurements started one hour after the insertion of the leaf into the chamber, to avoid any stress-induced BVOC emissions. After each new light level was set in the leaf chamber, 30 min passed before the measurement started to provide time for the leaf to acclimatize to the new conditions. To acknowledge possible contamination from the instruments, background samples were taken each day from the purge air in the branch chamber system and from the empty leaf chamber. All sample cartridges were sealed with caps made of Teflon-coated brass and stored at 3°C until analysis. At the end of each campaign, the measured leaves were collected and dried at 75°C for two days to measure dry weight.

PTR-MS measurements

A convenient way to measure BVOCs with high temporal resolution is to use PTR-MS technique. This method results in a fast response on-line measurement. By combining a time-of-flight (TOF) detector, i.e., PTR-TOF-MS, the time resolution is further improved. This instrument is capable of measuring full mass spectra 10 Hz time series, which is necessary for combining PTR-MS with direct eddy covariance technique (Müller et al., 2010; Ruuskanen et al., 2011). During field

campaigns in 2015, a PTR-TOF-MS (8000, Ionicon Analytik GmbH, Tyrol, Austria) was used to measure emissions of BVOCs on an ecosystem scale from P1. The idea behind PTR-MS technique is that it requires an ionization of the studied compound, which can be done by producing hydronium (H_3O^+) from pure water vapor in high voltage (Hansel et al., 1995; Lindinger et al., 1998; Ammann et al., 2004). Detection of masses and raw data analysis were done by the software PTRwid (Holzinger, 2015).

Particle measurements

Measurements of SOAs have traditionally been made by using larger smog chambers but during the last decades more attention has been put on the oxidation flow reactor (OFR). Compared to the smog chambers, OFRs are smaller, which make them suitable for field measurements. The smaller volume in OFRs, which could lead to more wall losses, is compensated with a shorter residence time in the chamber and studies have shown that measurements of chemical composition and mass yield by OFRs agree well to smog chambers (Bruns et al., 2015).

Oxidation flow reactor

A common OFR is the potential aerosol mass (PAM) reactor (designed at Pennsylvania State University), and in 2015 this type reactor was used to measure aerosol formation from P1 in Skrehalla. This PAM reactor consisted of a horizontal aluminum cylinder with a volume of approx. 13 l. An ultraviolet lamp produced OH and O_3 from oxygen and water, which later on oxidize incoming air. This process makes it possible to study aging of the atmospheric composition in a faster manner than it would take in the atmosphere.

Scanning mobility particle sizer

After the oxidative aging in the PAM reactor, the air flow from the reactor entered a scanning mobility particle sizer (SMPS) (Wiedensohler et al., 2012) and a high-resolution time-of-flight aerosol mass spectrometer (AMS) (Aerodyne Research Inc., MA, US) (DeCarlo et al., 2006). The SMPS measured the particle number size distribution in the range 11–600 nm (electrical mobility diameter). The SMPS consisted of a differential mobility analyzer (DMA) (TSI 3071, TSI Inc., MN, US) and a condensation particle counter (CPC) (TSI 3775, TSI Inc., MN, US). The AMS measured chemically resolved mass concentration in the interval of approx. 50–1000 nm (vacuum aerodynamic diameter).

Field measurements on *Salix*

Measurements of BVOC emissions from *Salix* trees were done between 2015 and 2017 (Table 1). The measurements in 2015 started in July and ended in September. In total, 142 samples were taken with the branch chamber during this growing season, where the major part of the measurements was done on an unknown variety of *S. viminalis* growing on P1. Campaigns done during 2016 were performed from May to October at different heights with both branch and leaf chambers on the variety Tora, growing on P2. Measurements with branch chambers resulted in 427 samples, and with the leaf chamber, 94 samples were taken and used for further analysis. The heights of the leaves were divided into three categories, lower (z_L , up to approx. 70% of the total canopy height (TCH) and representing shade-adapted leaves), higher (z_H , leaves growing above z_L and representing sun-adapted leaves) and middle (z_M , up to approx. 70% of TCH but growing at the edge of the plantation and assumed to experience similar conditions as z_H).

From May to September in 2017, 299 leaf chamber measurements were performed on P1–P4. The varieties studied in 2017 were Wilhelm, Tora, Inger and Ester.

Table 1. Details about field campaigns with leaf and branch chambers on *Salix* trees including year, period, height, location, plots, varieties, number of samples and in which paper they were used.

Year	Campaigns	Heights	Location	Plots/varieties	Chamber	Samples	Paper
2015	16–17 July	z_H	Skrehalla/	P1 & P2/ unknown <i>S.</i> <i>viminalis</i> and Tora	Branch	142	I
	28–31 July	z_H	58°16'55"N				
	4–7 Aug.	z_H	12°46'20"E				
	18–21 Aug.	z_H	and				
	1–4 Sep.	z_H	58°17'09"N				
	8 & 10–11 Sep.	z_M ; z_H	12°45'31"E				
2016	4–5 May	z_M	Skrehalla/	P2/Tora	Branch & leaf	427+94	I
	24 May	z_H	58°17'09"N				
	6–10 June	z_M ; z_H	12°45'31"E				
	19–23 June	z_M ; z_H					
	11–15 July	z_M ; z_H					
	26–29 July	z_L ; z_M ; z_H					
	15–17 Aug.	z_L ; z_M ; z_H					
	6–9 Sep.	z_L ; z_M ; z_H					
	10–13 Oct.	z_M ; z_H					
	2017	29 & 31 May					
2 & 5 June			and				
13 & 15 June			Billeberga/				
28 June			58°16'55"N				
5–6 & 9–10 July			12°46'20"E				
12–14 & 15 July			and				
22, 25–26 & 28 July			58°17'09"N				
1–2 Aug.			12°45'31"E				
28–31 Aug.			and				
5 & 7 Sep.			55°52'32.9"N				
			13°1'18.2"E				
			and				
			55°52'11.7"N				
		13°1'33.3"E					

Analysis of BVOC chamber measurements from *Salix*

GC-MS analysis

Adsorbent cartridge samples from the chamber measurements were analyzed with thermal desorption GC-MS (TD-GC-MS) instrument (UNITY2 thermal desorber, Markes International Ltd., Mid Glamorgan, UK) in combination with an ULTRA autosampler and GC-MS (7890A Series GC coupled with a 5975C inert MSD/DS Performance Turbo EI System, Agilent Technologies Inc., CA, US). Helium was used as carrier gas. Analysis of BVOCs was done using the software Enhanced ChemStation (MSD ChemStation E.02.01.1177, Agilent Technologies Inc., CA, US). Identification of the peaks in the mass spectra were done by injected pure standards or by the NIST 8.0 database. Concentrations of measured BVOCs were calculated by using ratios between the sample peak areas and standard peak areas. Only compounds with at least an area twice as large as the area in the background samples were included for further analysis.

Calculations of BVOC emissions

BVOC emission rates E ($\mu\text{g g}_{\text{dw}}^{-1} \text{h}^{-1}$) was calculated as (Ortega and Helmig, 2008):

$$E = \frac{C_2 - C_1}{m} \times Q \quad (1)$$

where C_2 ($\mu\text{g l}^{-1}$) is the concentration of the compounds taken out from the chamber, C_1 ($\mu\text{g l}^{-1}$) is the concentration of the compounds entering the branch chamber or in the empty leaf chamber, Q (l h^{-1}) is the flow rate of the purge air and m (g_{dw}) is the dried mass of the leaves.

Standardization of compounds that are dependent on both T and PAR were calculated according to Guenther et al. (1993). Standardized (STD) values for T and PAR were 303.15 K and $1000 \mu\text{mol m}^{-2} \text{s}^{-1}$ respectively:

$$E = E_s \times C_T \times C_L \quad (2)$$

where E ($\mu\text{g g}_{\text{dw}}^{-1} \text{h}^{-1}$) is the measured emission at T (K) and PAR ($\mu\text{mol m}^{-2} \text{s}^{-1}$) inside the chamber. E_s ($\mu\text{g g}_{\text{dw}}^{-1} \text{h}^{-1}$) is the STD emission, C_T and C_L are correction factors for temperature and light, which are defined by

$$C_L = \frac{\alpha C_{L1} PAR}{\sqrt{1 + \alpha^2 PAR^2}} \quad (3)$$

where α (=0.0027) and C_{L1} (=1.066) are empirical coefficients (Guenther et al., 1993), and

$$C_T = \frac{\exp\left(\frac{C_{T1}(T-T_s)}{RT_s T}\right)}{1 + \exp\left(\frac{C_{T2}(T-T_M)}{RT_s T}\right)} \quad (4)$$

where C_{T1} (=95 000 J mol⁻¹), C_{T2} (=230 000 J mol⁻¹) and T_M (=314 K) are empirical coefficients (Guenther et al., 1993). The parameter T_s (=303.15 K) is STD temperature and R (=8.314 J K⁻¹ mol⁻¹) is the universal gas constant.

Standardization of temperature-dependent compounds were done as

$$E = E_s \times e^{\beta(T-T_s)} \quad (5)$$

where E (μg g_{dw}⁻¹ h⁻¹) is the measured emission rate and E_s (μg g_{dw}⁻¹ h⁻¹) is the STD emission rate at temperature T (K). The parameter T_s (=303.15 K) is STD temperature and β (=0.09 K⁻¹ for MTs and 0.17 K⁻¹ for SQTs) is an empirical constant (Guenther et al., 1993; Helmig et al., 2007).

Results and discussion

Phenological and genetical influences on BVOC emissions from *Salix* (Papers I and II)

As studies have pointed out, many factors are involved when it comes to affect the BVOC emission rates from plants (Guenther et al., 1997; Laothawornkitkul et al., 2009). For *Salix*, a mix of different STD emission factors exist in the published literature. The STD emission factor for isoprene, which has so far been the most studied compound from *Salix*, varies almost 20-fold when considering *Salix* varieties used in biofuel plantation (Olofsson et al., 2005; Copeland et al., 2012; Morrison et al., 2016). The average STD isoprene emission for the study in 2015 and 2016 was $45.2 (\pm 42.9) \mu\text{g g}_{\text{dw}}^{-1} \text{h}^{-1}$, which is almost twice as much as the highest reported value from commercial *Salix* trees (Copeland et al., 2012). The STD emission for the varieties in 2017 was $33.2 (53.4 \pm \mu\text{g g}_{\text{dw}}^{-1} \text{h}^{-1})$. One reason to the variability in the STD emission rates can be related to the different technique employed (e.g., leaf-scale or canopy-scale) for measuring the fluxes. Further, the physiological changes in the plants related to different phenological stages is another factor that influence the emission rates. The development for isoprene emission has been suggested to vary in at least four stages (Monson et al., 1994; Guenther et al., 1997; Pétron et al., 2001), which is one of explanations for how the average STD isoprene emission varied during 2016 at P2 for the different months ($1.6\text{--}42.4 \mu\text{g g}_{\text{dw}}^{-1} \text{h}^{-1}$). The summer months (June–August) had similar average STD emission rates and the autumn months (September–October) had considerably lower STD emission rates (Table 2). A decreasing isoprene trend for the STD emission was also observed between July and September at P1 during 2015. The plant physiological processes behind the isoprene emissions are suggested to depend on isoprene synthase activity (Monson et al., 1992; Kuzma and Fall, 1993). This synthase activity changes through the season (Schnitzler et al., 1997), and long-term predictions should be corrected for this influence. Even though T and PAR were the main factors that influenced the isoprene emissions and is the reason why eq. 2 has been widely used to describe these emissions, this equation cannot explain why average STD isoprene emission was lower in May compared to June and July, despite that T_{C} and PAR_{C} were higher in May. An additional correction factor in eq. 2 has been applied by, e.g., Guenther et al. (1997) and Schnitzler et al. (1997), which takes long-term processes into account. But since this factor could be species-

dependent, more emphasis needs to be put on how it varies for different plants, and conducted in natural growing conditions.

The STD MT emission at P2 in 2016 decreased from May ($0.590 \pm 0.306 \mu\text{g g}_{\text{dw}}^{-1} \text{h}^{-1}$) to October ($0.022 \pm 0.028 \mu\text{g g}_{\text{dw}}^{-1} \text{h}^{-1}$) and a decreasing trend was found in 2017 for the other site (P3–P4) as well. Studies conducted on *Salix* have shown that close after budbreak, enhanced emissions of MTs have been observed (Hakola et al., 1998; Hakola et al., 1999), but since the budbreak was not recorded in these years, it is difficult to confirm this result. No SQTs were emitted in May and October at P2 in 2016, which indicates that these compounds are emitted during a shorter season compared to, e.g., isoprene and MTs, and also points out the need for a parameter that takes the seasonality into account.

Table 2. Average emission (mean and standard deviation, $\mu\text{g g}_{\text{dw}}^{-1} \text{h}^{-1}$) for isoprene, monoterpenes (MTs), sesquiterpenes (SQTs) and other VOCs, and average standardized (STD) emission (mean and standard deviation, $\mu\text{g g}_{\text{dw}}^{-1} \text{h}^{-1}$) for isoprene, MTs and SQTs during 2015 and 2016. Average T_c ($^{\circ}\text{C}$) and PAR_c ($\mu\text{mol m}^{-2} \text{s}^{-1}$) together with standard deviation for each month.

	2015			2016					
	July	Aug.	Sep.	May	June	July	Aug.	Sep.	Oct.
Isoprene	38.3 (43.3)	49.8 (37.2)	5.1 (5.4)	17.4 (12.4)	26.0 (21.5)	16.2 (16.9)	34.4 (34.9)	7.3 (9.5)	0.1 (0.3)
MTs	0.317 (0.228)	0.219 (0.145)	0.068 (0.045)	0.305 (0.140)	0.291 (0.209)	0.129 (0.078)	0.051 (0.020)	0.063 (0.037)	0.003 (0.004)
SQTs	0.031 (0.024)	0.035 (0.033)	0.023 (0.014)	0 (0)	0.003 (0.005)	0.015 (0.018)	0.084 (0.057)	0.001 (0.002)	0 (0)
other VOCs	0.441 (0.039)	1.640 (0.149)	0.207 (0.021)	0.330 (0.034)	0.114 (0.016)	0.499 (0.083)	0.398 (0.052)	0.232 (0.033)	0.092 (0.017)
STD isoprene	74.8 (42.8)	70.4 (43.0)	19.2 (16.1)	29.9 (20.4)	42.4 (23.5)	35.8 (25.4)	42.0 (35.0)	13.8 (12.9)	1.6 (4.8)
STD	0.580 (0.292)	0.268 (0.163)	0.286 (0.182)	0.590 (0.306)	0.488 (0.330)	0.257 (0.186)	0.065 (0.032)	0.139 (0.075)	0.022 (0.028)
STD	0.076 (0.044)	0.040 (0.038)	0.171 (0.113)	0 (0)	0.004 (0.007)	0.021 (0.026)	0.054 (0.046)	0.003 (0.009)	0 (0)
T_c	23.2 (4.7)	28.9 (2.9)	19.3 (3.4)	26.1 (2.5)	25.1 (5.8)	24.2 (4.5)	31.1 (6.8)	25.0 (4.6)	8.7 (2.7)
PAR_c	562 (397)	467 (230)	329 (192)	951 (448)	710 (479)	461 (354)	704 (459)	403 (307)	89 (125)

Previous studies have put little focus on finding emission potentials for non-terpenes, and how they differ through the season since their emission rates only have been less significant when studying SRCs (Copeland et al., 2012). Grouped together as other VOCs, the average emission during the different months in 2015 and 2016 were usually lower than $0.500 \mu\text{g g}_{\text{dw}}^{-1} \text{h}^{-1}$ for this group, except in the beginning of August 2015 (Table 2 and Figure 7). During this month, emissions of compounds like benzaldehyde, hexanal and nonanal increased approx. 4-fold. Due to the outbreak of *Melampsora* in 2015, it is likely that the fungus influenced the emission rates of these compounds. Many studies have shown that stress-induced compounds, such as benzaldehyde, nonanal, octanal, decanal and hexanal have been emitted when the plants were suffering from abiotic and biotic stresses (Hilderbrand, 1989; Andersen et al., 1994; Wildt et al., 2003; Misztal et al., 2015; Jiang et al., 2016). Especially, nonanal and hexanal have been observed from many plant species

affected by pathogens (Hilderbrand 1989; Andersen et al., 1994; Wildt et al., 2003). Green leaf volatiles (e.g., hexanal) are known to act as a defense against pathogens (Hilderbrand, 1989), and Toome et al. (2010) showed that willow trees emitted GLVs when they were infected by *Melampsora*. Besides this, it was harder to relate the emissions of other VOCs to a seasonal trend but like the terpenes, other VOCs had substantially lower emissions in the late growing season. This was also the case in 2017 for P3 and P4, where the emissions of other VOCs were many times lower in September compared to May. *Melampsora* was believed to have caused the higher emissions of caryophyllene in August 2015, and may have suppressed the isoprene emissions (Toome et al., 2010). Stress-induced emission is harder to include in algorithms but would be required to better estimate the emissions from vegetation.

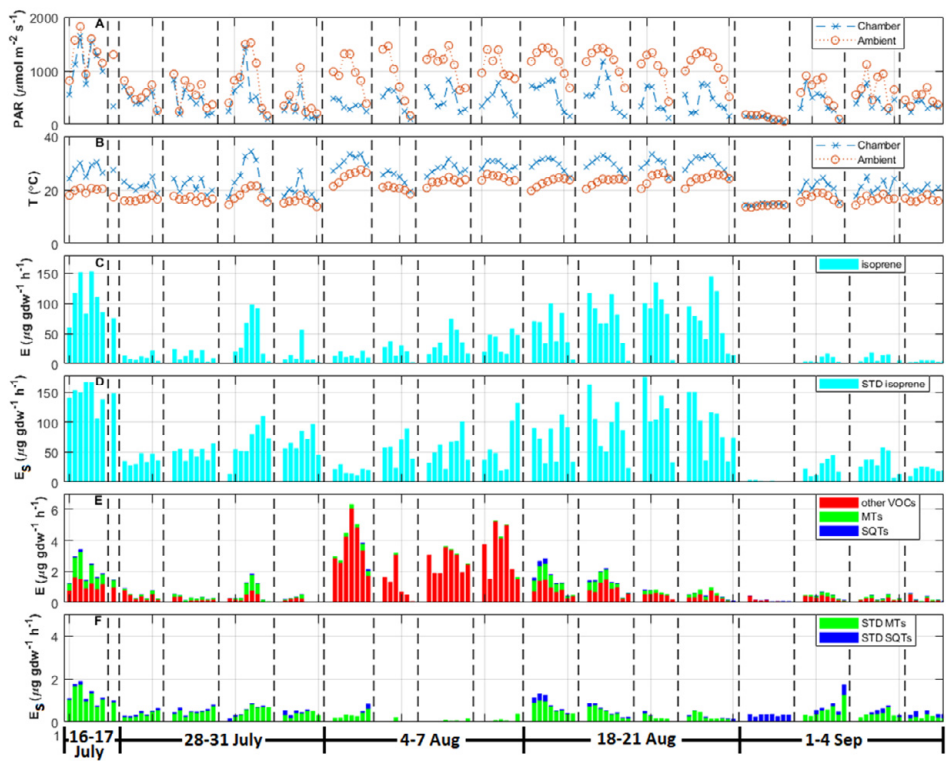

Figure 7. Measurements from P1 in 2015. A) PAR ($\mu\text{mol m}^{-2} \text{s}^{-1}$) values for chamber condition (PAR_c , blue cross and dashed line) and ambient condition (red circle and dotted line). B) Temperature ($^{\circ}\text{C}$) values for chamber condition (T_c , blue cross and dashed line) and ambient condition (red circle and dotted line). C) Emission rates ($\mu\text{g g}_{\text{dw}}^{-1} \text{h}^{-1}$) for isoprene (cyan). D) Standardized (STD) emission rates ($\mu\text{g g}_{\text{dw}}^{-1} \text{h}^{-1}$) for isoprene (cyan). E) Emission rates ($\mu\text{g g}_{\text{dw}}^{-1} \text{h}^{-1}$) of other VOCs (red), monoterpenes (MTs, green) and sesquiterpenes (SQTs, blue). F) STD emission rates ($\mu\text{g g}_{\text{dw}}^{-1} \text{h}^{-1}$) for monoterpenes (MTs, green) and sesquiterpenes (SQTs, blue). Vertical dashed lines separate the different days. Each bar represents individual measurements.

A clear difference was observed when comparing the different varieties in 2017. The STD isoprene emission from Wilhelm (50.33 ± 72.63 μg g_{dw}⁻¹) was almost three times higher and statistically significant compared to Tora (17.99 ± 27.18 μg g_{dw}⁻¹) (Table 3). The STD average isoprene emissions from Ester and Inger differed less, and their emission rates followed the same curve up to 450 μmol m² s⁻¹, thereafter emissions from Ester levelled out faster than for Inger (Figure 8 A,B). Isoprene emission from Wilhelm showed a strong increase for the measured light levels and no tendency of leveling out, even after 1000 μmol m² s⁻¹. In this sense, Wilhelm are the least appropriate variety for SRPs among these four varieties if planted near pollution sources (e.g., trafficked roads or industrial areas) because of the higher risk to produce O₃ and PAN (Folberth et al., 2005; Watson et al., 2006).

Table 3. Isoprene, monoterpenes (MTs), sesquiterpenes (SQTs) and total terpenoid emissions (μg g_{dw}⁻¹ h⁻¹, mean and standard deviation) for the different *Salix* varieties. Standardized (STD) emission rates for isoprene, MTs and SQTs (μg g_{dw}⁻¹ h⁻¹, mean and standard deviation) for the different varieties. Average and standard deviation for temperature (T_c, °C), photosynthetically active radiation (PAR_c, μmol m⁻² s⁻¹) and relative humidity (RH_c, %) in the leaf chamber.

	Tora, n = 90	Wilhelm, n = 104	Ester, n = 53	Inger, n = 52
isoprene (μg g _{dw} ⁻¹ h ⁻¹)	4.00 (7.05)	12.66 (20.63)	6.11 (9.06)	7.77 (11.65)
MTs (μg g _{dw} ⁻¹ h ⁻¹)	1.56 (0.62)	0.80 (0.28)	1.25 (1.01)	1.87 (1.24)
SQTs (μg g _{dw} ⁻¹ h ⁻¹)	0.40 (0.28)	0.22 (0.24)	0.57 (0.44)	0.56 (0.26)
Sum (μg g _{dw} ⁻¹ h ⁻¹)	5.96 (2.06)	13.68 (5.84)	7.93 (2.73)	10.02 (3.32)
STD isoprene (μg g _{dw} ⁻¹ h ⁻¹)	17.99 (27.18)	50.53 (72.63)	25.84 (34.36)	32.75 (47.82)
STD MTs (μg g _{dw} ⁻¹ h ⁻¹)	5.84 (1.90)	3.09 (0.99)	3.44 (2.35)	6.00 (3.21)
STD SQTs (μg g _{dw} ⁻¹ h ⁻¹)	2.43 (1.63)	1.30 (1.53)	3.76 (3.20)	3.71 (1.91)
T _c (°C)	19.0 (2.1)	19.0 (2.0)	18.9 (2.2)	19.0 (2.3)
PAR _c (μmol m ⁻² s ⁻¹)	571 (487)	551 (477)	561 (477)	573 (494)
RH _c (%)	61.5 (13.0)	53.9 (16.9)	48.2 (9.5)	51.4 (8.9)

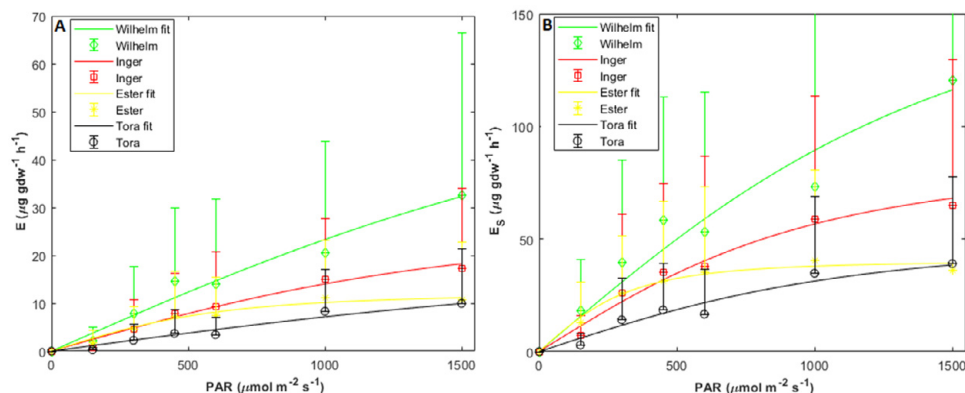

Figure 8. A) Isoprene emission rates (μg g_{dw}⁻¹ h⁻¹, mean + standard deviation, n = 7–16) and fitted curves for Wilhelm (green diamonds and line), Inger (red boxes and line), Ester (yellow stars and line) and Tora (black circles and line) at different PAR values (μmol m² s⁻¹). B) Standardized isoprene emission rates (μg g_{dw}⁻¹ h⁻¹, mean + standard deviation, n = 7–16) and fitted curves for Wilhelm (green diamonds and line), Inger (red boxes and line) and Tora (black circles and line) at different PAR (μmol m² s⁻¹) values.

Average measured MT emission (0.8 ± 0.3 μg g_{dw}⁻¹ h⁻¹) and SQT emission (0.2 ± 0.2 μg g_{dw}⁻¹ h⁻¹) from Wilhelm were lower than from the other varieties (1.25–1.87

$\mu\text{g g}_{\text{dw}}^{-1} \text{h}^{-1}$ (MTs) and $0.40\text{--}0.57 \mu\text{g g}_{\text{dw}}^{-1} \text{h}^{-1}$ (SQTs)). This was also the case for the average STD MT and SQT emissions. Ocimene was a dominant MT for all varieties except for Ester. Instead, camphene and limonene were the dominantly emitted MTs from this variety (Figure 9A). Limonene was also the most abundant MT from Inger. Emissions of linalool was abundant from Wilhelm and Tora but not from Ester and Inger. No caryophyllene was observed from Wilhelm (Figure 9B). Response to light for MTs and SQTs varied as well for the varieties. No correlation between PAR and the compounds ocimene and linalool was seen for Ester, but all the other varieties showed an increasing emission rate trend with PAR. Inger was the only variety that showed a clear light response for the emission of caryophyllene. These results point out how important the genetical influence can be for BVOC emissions even within the same genus or species, which has been reported previously (Staudt et al., 2004). Genetical influence on BVOC emission has been found for other deciduous and coniferous trees, and plants with same provenances do not necessarily respond in the same way. For instance, oak species have been considered mainly as isoprene emitters but some can be significant MT emitters (Pio et al., 1993; Kesselmeier et al., 1996). How the emission is influenced by light is another trait that can differ within the same species. According to Evans et al. (1985), MT emission from spruce was little influenced by PAR, whilst Steinbrecher et al. (1993) reported a significant dependence. Tingey et al. (1980) found no influence of PAR on MT emissions from pine but Tarvainen et al. (2005) reported that 1,8-cineole was affected by light. Extrapolating emissions among species must be done prudently and based on representative measurements (Kesselmeier et al., 1996).

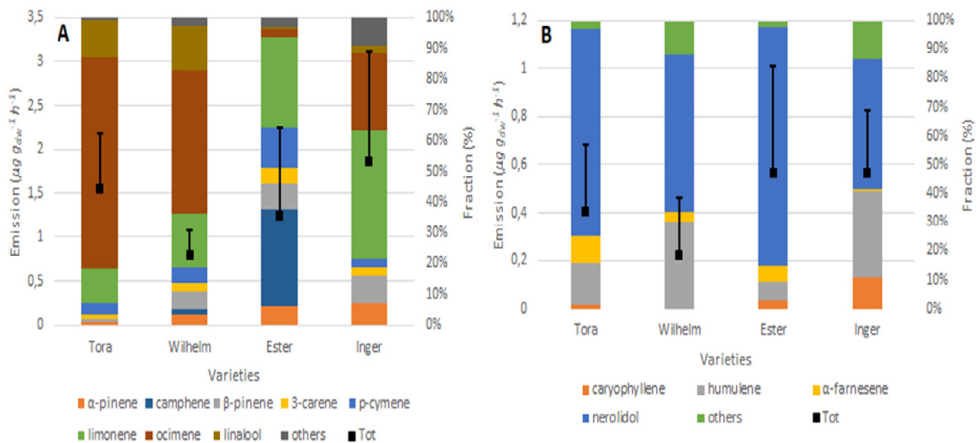

Figure 9. A) Total MT emissions (black square, $\mu\text{g g}_{\text{dw}}^{-1} \text{h}^{-1}$, mean + standard deviation, $n = 52\text{--}104$) and the contribution from each MT for the different varieties. Others includes eucalyptol, d-phellandrene, terpinolene, γ -terpinene and one unknown compound. B) Total SQT emissions (black square, $\mu\text{g g}_{\text{dw}}^{-1} \text{h}^{-1}$, mean + standard deviation, $n = 52\text{--}104$) and the contribution from each SQT for the different varieties. Others includes copaene and one unknown compound.

Comparison between different heights and light conditions (Papers I and IV)

Light response curves during 2016 showed that the height within the canopy had a large impact on the BVOC emission rates. The emission of isoprene, both measured and STD, differed a factor two when comparing more sun-adapted leaves (z_H and z_M) to shade-adapted leaves (z_L). This light response resulted in that the average STD isoprene emission rate was $96.1 (\pm 64.6) \mu\text{g g}_{\text{dw}}^{-1} \text{h}^{-1}$ (or $5.47 \pm 0.26 \text{ mgC g}_{\text{dw}}^{-1} \text{h}^{-1}$) at z_H and $51.8 (\pm 32.9) \mu\text{g g}_{\text{dw}}^{-1}$ (or $2.88 \pm 1.57 \text{ mgC g}_{\text{dw}}^{-1} \text{h}^{-1}$) at z_L . The difference between the emission rates was especially pronounced for the lower PAR values, and the emissions at z_H increased all the way up to $1000 \mu\text{mol m}^{-2} \text{s}^{-1}$ (Figure 10A,B). This pattern has been reported by others (Sharkey et al., 1991; Niinemets et al., 2010), which points out that light acclimatization is an important factor for emissions of, e.g., isoprene. Therefore, estimating isoprene emissions on a landscape or regional level can be misleading if simulations are based on an emission potential that represents only one height level. The shape of the isoprene curves followed a hyperbolic curve similar to the one that can be observed for A (Monson and Fall, 1989), but since the ratio between emitted isoprene and A (E/A) increased with PAR (Figure 11), the leaves lost more C as isoprene for the higher PAR values compare to the lower PAR values. Moreover, leaves at z_H had a higher E/A ratio compared to leaves at z_L , showing that the light-adapted leaves in the upper part of the canopy lost more C as isoprene than less light adapted leaves.

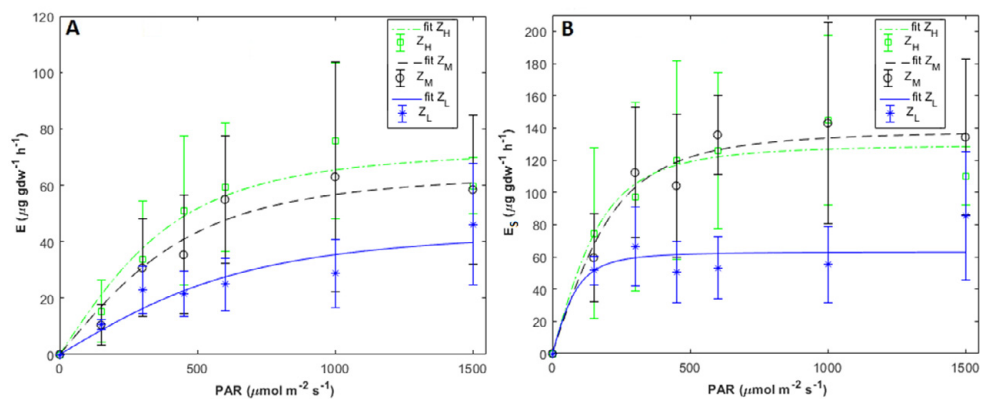

Figure 10. A) Average isoprene emissions rates ($\mu\text{g g}_{\text{dw}}^{-1} \text{h}^{-1}$, mean \pm standard deviation, $n = 3-6$) and fitted curves for different PAR values ($\mu\text{mol m}^{-2} \text{s}^{-1}$) from the different height levels, z_H (green boxes and dot-dashed line), z_M (black circles and dashed line) and z_L (blue stars and line). B). Average standardized isoprene emission rates ($\mu\text{g g}_{\text{dw}}^{-1} \text{h}^{-1}$, mean \pm standard deviation, $n = 3-6$) and fitted curves for different PAR ($\mu\text{mol m}^{-2} \text{s}^{-1}$) values from the different height levels, z_H (green boxes and dash-dotted line), z_M (black circles and dashed line) and z_L (blue stars and line).

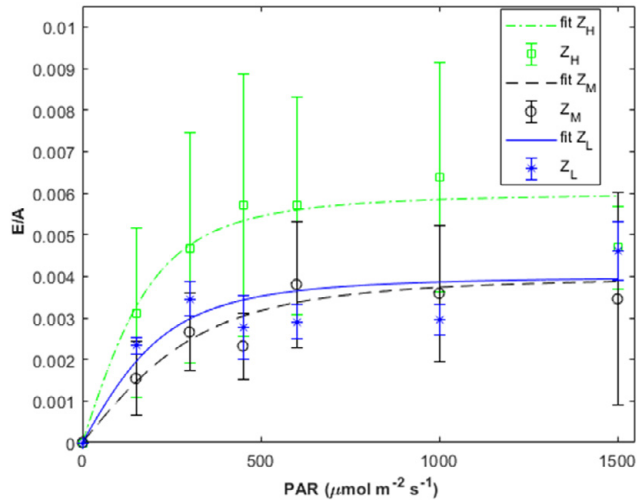

Figure 11. Ratio between isoprene emission and net assimilation (E/A , dimensionless, mean \pm standard deviation, $n = 3-5$) and fitted curves at different height levels, z_H (green boxes and dot-dashed line), z_M (black circles and dashed line) and z_L (blue stars and line) for the measured PAR ($\mu\text{mol m}^{-2} \text{s}^{-1}$) values.

Another strong evidence that emissions of terpenes are adapted to different light conditions was seen when comparing MT and SQT emissions between shaded and sun-adapted leaves. Shade-adapted *Salix* leaves emitted less MTs than sun-adapted leaves and only limonene was seen from the former, while α -pinene, limonene, p-cymene, ocimene and 3-carene were observed from the latter. The total average MT emission from z_H ($0.078 \pm 0.085 \mu\text{g g}_{\text{dw}}^{-1}$ or $0.004 \pm 0.005 \text{ mgC m}^{-2} \text{ h}^{-1}$) was almost twice as high than from z_L ($0.045 \pm 0.029 \mu\text{g g}_{\text{dw}}^{-1}$ or $0.002 \pm 0.002 \text{ mgC m}^{-2} \text{ h}^{-1}$). Further, no SQTs were emitted from the shaded leaves but four (α -farnesene, caryophyllene, humulene and nerolidol) were emitted from the sun-adapted leaves. Ocimene and α -farnesene showed an increasing emission trend for some of the PAR values (Figure 12), but this pattern was only observed from the sun-adapted leaves, since the shade-adapted did not emit these compounds.

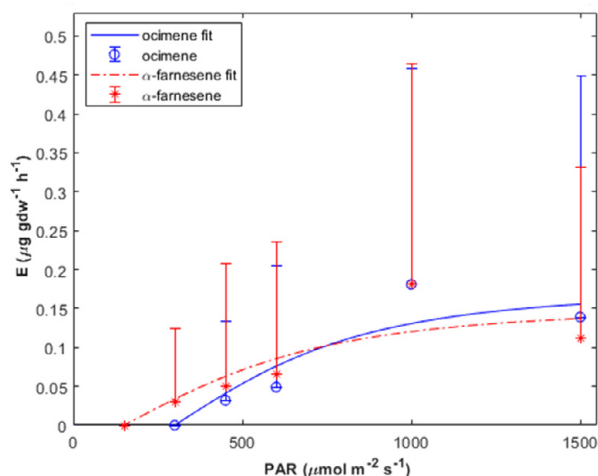

Figure 12. Average emission ($\mu\text{g g}_{\text{dw}}^{-1} \text{h}^{-1}$, mean + standard deviation, $n = 11$) and fitted curves for ocimene (blue circles and line) and α -farnesene (red stars and dot-dashed line) for the sun-adapted leaves (Z_M and Z_H) and different PAR ($\mu\text{mol m}^{-2} \text{s}^{-1}$) values.

When grouping non-terpenes together, higher emissions were observed from the lower height (Z_M) compared to the higher (Z_H), despite the similar light conditions for these locations. This result indicates that the difference is not a result to light adaption.

The height comparison for the BVOC emission from spruce showed that there was a significant difference for the emissions of camphene and limonene in Taastrup. The reason why other compounds (e.g., ocimene and isoprene) did not differ could be due to the wide spacing and consequently similar irradiation conditions for all heights (2 m, 5.5 m and 12.5 m). In Norunda, all the emissions for isoprene, MTs and SQTs differed when comparing the lowest (3 m) and the highest (20 m) height. Emissions of isoprene and MTs were even higher at 3 m compared to 20 m. Different explanations were found, e.g., the lower height had in periods higher irradiance than at 20 m (Wang, 2018), and the needles at 3 m were older with a low percentage of newly produced shoots, which can influence the concentrations of terpenes in needles (Merk et al., 1988).

Impact of the surrounding area (e.g., dense or sparse forest), shape of the canopy, phenological stages of the leaves and needles add complexity to acquire reliable height emission factors on an ecosystem-scale.

Impact of age on BVOC emissions (Paper I and II)

A comparison between the first and second growing year trees showed that all varieties in their first growing season emitted a substantially higher average emission of other VOCs ($15.70\text{--}46.74 \mu\text{g g}_{\text{dw}}^{-1} \text{h}^{-1}$) than during the second growing

season ($2.46\text{--}4.70 \mu\text{g g}_{\text{dw}}^{-1} \text{h}^{-1}$). The average emissions of some of the most emitted other VOCs from the first growing year trees were hexanal ($0.826\text{--}4.920 \mu\text{g g}_{\text{dw}}^{-1} \text{h}^{-1}$), benzaldehyde ($0.436\text{--}3.204 \mu\text{g g}_{\text{dw}}^{-1} \text{h}^{-1}$), octanal ($0.354\text{--}3.149 \mu\text{g g}_{\text{dw}}^{-1} \text{h}^{-1}$), furfural ($0.148\text{--}3.069 \mu\text{g g}_{\text{dw}}^{-1} \text{h}^{-1}$) and acetophenone ($0\text{--}2.462 \mu\text{g g}_{\text{dw}}^{-1} \text{h}^{-1}$). Many of these were less common for the one year older trees. One explanation for this difference could be that the saplings need a stronger defense before they have reached a growing stage, which provides a better prerequisite for establishment and survival. Mature trees might be less affected by damage than young trees and more capable to survive (Palo, 1984). The average emission of other VOCs from Tora on P2 in 2016 (fourth growing season) was also three times lower than the average emission from first growing season Tora on P2. Compounds other than terpenes (e.g., GLVs) have usually been studied when considering stress. Even if non-terpenes serve as protection for the plants, they can also contribute to formation of aerosols (Pandis et al., 1992 and references therein; Misztal et al., 2015; Palm et al., 2018).

The STD isoprene emission results from fourth growing season Tora at P2 in 2016 ($95.0 \pm 63.2 \mu\text{g g}_{\text{dw}}^{-1} \text{h}^{-1}$) and the first growing season Tora at P2 in 2017 ($20.9 \pm 33.5 \mu\text{g g}_{\text{dw}}^{-1} \text{h}^{-1}$), showed that the former emitted around five times more isoprene and that the older trees reached almost the same rate ($66.4 \mu\text{g g}_{\text{dw}}^{-1} \text{h}^{-1}$) at $150 \mu\text{mol m}^2 \text{s}^{-1}$ as the younger ($55.1 \mu\text{g g}_{\text{dw}}^{-1} \text{h}^{-1}$) did at $1500 \mu\text{mol m}^2 \text{s}^{-1}$ (Figure 13). Comparing STD MT emissions from Tora between the first and the fourth growing season showed that the emission rates from the younger trees ($5.240 \pm 2.272 \mu\text{g g}_{\text{dw}}^{-1} \text{h}^{-1}$) were several times higher than the older trees ($0.359 \pm 0.184 \mu\text{g g}_{\text{dw}}^{-1} \text{h}^{-1}$). More MTs were emitted from the younger trees (9 MTs: α -pinene β -pinene, d-phellandrene, eucalyptol, limonene, linalool, ocimene, p-cymene and 3-carene) compared to the older (5 MTs: α -pinene, limonene, ocimene, p-cymene and 3-carene). The STD SQT emissions for Tora differed as well and the younger trees emitted approx. 2.5 times higher average emission rate compared to the fourth growing season trees. The response to light also showed that linalool increased with PAR but only for the younger trees, whereas α -farnesene increased with PAR but only for the older trees.

From the literature, it is not clear how the age influences the emission rates. Although studies including age when measuring BVOC emissions are limited, some have reported that the age can influence the emission rates. For instance, Kim et al. (2005) and Lim et al. (2008) showed that the age had a significant impact on the MT emission rates from conifers. Nuñez and Pio (2001) reported that isoprene emission differed between young and adult eucalyptus trees. But it is likely that the impact of age is species-dependent and for some plants it might not change the BVOC emissions considerably.

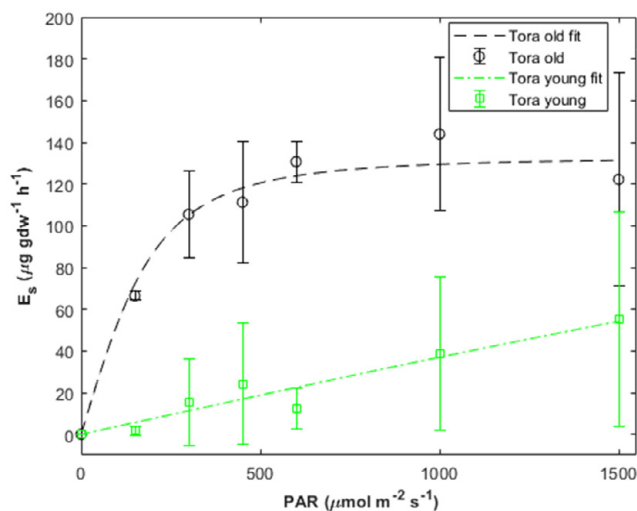

Figure 13. Standardized isoprene emission rates ($\mu\text{g gdw}^{-1} \text{h}^{-1}$, mean \pm standard deviation, $n = 7\text{--}16$) and fitted curves for first growing season (green boxes and dash-dotted line) and fourth growing season (black circles and dashed line) trees belonging to Tora on P2 at different PAR ($\mu\text{mol m}^{-2} \text{s}^{-1}$) values.

LUCC and impact on air quality from *Salix* (Paper I–IV)

The measurements performed from July 2015 to September 2017, showed a high contribution of isoprene to the atmosphere from *Salix* trees even if the rates differed among varieties. Higher emissions of isoprene were observed from late spring to early autumn. Emissions of other compounds were in general minor compared to isoprene with some exceptions, e.g., for saplings and during early season. The landcover is crucial for what kind of BVOC that will be emitted to the atmosphere. The Swedish landcover is dominated by boreal forest (68.8%), containing approx. 40.3% Norway spruce, 39.3% Scots pine, 12.4% birch and minor fractions of some others species (Skogsdata, 2020). Norway spruce trees are known to emit terpenes and particularly MTs, but they can also emit isoprene up to about the same rates as MTs (Kesselmeier and Staudt, 1999). Studies conducted in boreal forest have shown that the major part of the emitted terpenoids is made up by MTs (Rinne et al., 2000; Tarvainen et al., 2007; Rinne et al., 2009). The contribution to this MT emission is essentially from spruce and pine, although deciduous trees can contribute to the emission and especially depending on the season (Tarvainen et al., 2007; Rinne et al., 2009). The latitudinal study of Norway spruce in Sweden and Europe (Paper IV), showed that emission rates were similar but with some emission profile variability, regardless of the adaption to different environmental growing conditions at each location. However, comparing compounds separately resulted in different results. For example, limonene was a major emitted MT from the trees on all sites except in Skogaryd. Contribution from 3-carene was minor in Norunda, but in

Piikkiö it was significant, despite the similar latitude at these sites. The genetical influence among the different studied spruce trees was more important to the emission profile than climatic adaptation. Compared to *Salix* trees, all spruce sites had considerably lower emissions of isoprene and the average STD isoprene emission for the spruce sites was $<1 \mu\text{g g}_{\text{dw}}^{-1} \text{h}^{-1}$. Different species of pine have been reported as negligible isoprene emitters as well (Kesselmeier and Staudt, 1999). A LUCC, where coniferous forest such as spruce or pine is converted into SRC fields with *Salix* would drastically change the atmospheric concentrations of isoprene. This LUCC would in turn increase the risk of production of regional pollutions, e.g., O_3 and PAN, if anthropogenic sources of NO_x are sufficiently close to the plantation (Wang and Shallcross, 2000; Ryerson et al., 2001; Atkinson and Arey, 2003; Folberth et al., 2005). On the other hand, the spruce trees emitted more MTs than the older *Salix* trees and especially α -pinene, β -pinene and limonene were some of the most abundant MTs emitted by spruce. The average emission of α -pinene was approx. 4–60 times higher from spruce compared to the *Salix* trees studied 2015–2017. Spruce trees in Norunda have shown to be able to emit both α -pinene and β -pinene up to approx. $60 \mu\text{g g}_{\text{dw}}^{-1} \text{h}^{-1}$ (Wang et al., 2017), which is about the same magnitude as isoprene emitted from *Salix*. Monoterpenes are able to foster SOA production and in particular α -pinene, β -pinene and limonene have been reported to act as precursors for aerosol formation (Paulson et al., 1990; Pandis et al., 1992; Zhang et al., 1992; Ehn et al., 2014; Mutzel et al., 2016). Therefore, replacing spruce forest with *Salix* trees could reduce the number of particles and diminish the albedo in the atmosphere, which might lead to a reinforced effect on global warming (Boucher et al., 2013).

The measurements executed with the PAM reactor was unable to produce any aerosols at P1 during the summer 2015 (Paper III). The simulated aging in the reactor could neither increase the mass nor the number concentration significantly. The explanation for this was the lack of precursors, such as MTs. Ecosystem scale measurements of MTs concentrations by the PTR-TOF-MS gave an average value of approx. 140 ppt and for the MTs, and the sum of benzene, toluene and xylenes (BTX) was even lower (96 ppt). The concentration of MTs and BTX would have needed to be around one order of magnitude higher to result in a visible mass increase in the reactor. Manual measurements during daytime from the ambient air close to the inlet of the PAM reactor also confirmed the low MT concentration, which was 28 ppt (not published data). Since no measurements with the PAM reactor was made in spring, it is not possible to exclude any particle formation during this time of the year, because higher MTs emission during early growing season might increase the precursors needed for generating SOAs. Also, since the young *Salix* trees were able to emit higher rates of MTs and other VOCs, it is more likely to find increased production of aerosols from saplings or during the first growing season than from older trees.

No measurements of O_3 were performed between 2015 and 2017 but a study done about 15 km away from P1, measured isoprene from a willow coppice plantation

and their measurements could not reproduce any O₃ in their chemistry model that they used (Olofsson et al., 2005). Nevertheless, *Salix* trees exceed by far the terpene emissions from crops and grassland. Many studies have presented substantially lower emission rates of isoprene (0–0.5 μg g_{dw}⁻¹ h⁻¹) from, e.g., grassland, wheat, oat, rape, sugar beet and potato, compared to *Salix* (Winer et al., 1992; König et al., 1995; Karl et al., 2009; Morrison et al., 2016). Due to the low isoprene from traditional crops, O₃ formation is considerably higher in areas where both pollutions and isoprene are abundant (Ryerson et al., 2001). An expansion of SRPs with fast-growing plants, like *Salix* or other species with high isoprene emission (e.g., *Populus*), have to be strategically located to assure that the prerequisites for O₃ production are minimized. If not, large upscaling of SRPs could result in an increase of photochemical smog pollutions, which in turn could lead to reduced biomass production, additional premature deaths and economical costs (Fumigalli et al., 2001; Ryerson et al., 2001; Van Dingenen et al. 2009; Ashworth et al., 2012; Wagg et al., 2012; Ashworth et al., 2013; Beltman et al., 2013; Calvete-Sogo et al., 2014; Fann et al., 2015).

Conclusions and outlook

The aim of the work presented in this thesis was to study BVOC emissions from *Salix* trees that are commercially used for producing renewable energy. The influence by different factors such as seasonality, genetic diversity, height and age were studied in order to investigate the variability in the emissions. All the manual BVOC measurements were done on a leaf scale by using leaf and branch chambers combined with GC-MS analysis. Measurements of particle formation near the *Salix* SRP, and BVOCs measurements from spruce, were a part of the thesis work to assess how an expansion of *Salix* plantations could influence the air quality locally.

The measurements in 2015, 2016 and 2017 showed that isoprene was the major compound throughout the most of the growing season (Papers I and II), in accordance to what have been found in previous studies. Isoprene emissions peaked between June and August. High emissions were observed already in the beginning of May and until September, but in October the emissions were negligible. The driving factors for the isoprene emissions were mainly temperature and PAR but the phenological related changes in the leaves was also believed to influence the emissions. The seasonal trend for MTs seemed to decline from spring to autumn. Ocimene was normally the dominant MT compound emitted but was not observed in October. Caryophyllene dominated among the SQTs but this group contributed with the lowest amount to the total BVOC emission. Emissions of SQTs peaked in August and enhanced emissions of caryophyllene during summer was likely a response to biotic stress caused by *Melampsora*. No SQTs were observed in May and October 2016, which indicated that the season for these compounds were shorter than for isoprene and MTs. Non-terpenes did not show any clear seasonal pattern but there was a substantially increase for some of the other VOCs in August 2015, which was explained by the rust infestation (*Melampsora*). Compounds like nonanal, benzaldehyde and hexanal increased up to four times during this month. Stress-induced BVOC emissions are hard to predict and implement in models, since the response of the plants are probably species-specific and related to how severe the damage is. Another crucial factor that makes it difficult to estimate these impacts depends on the ability for pathogens and herbivores to adapt to the climate change. Nevertheless, it is clear that stress leads to elevated emissions and needs to be included in models to better estimate regional atmospheric BVOC budgets.

Studies have revealed that the genetical influence on the BVOC emission is important. Emission rates and blend can differ, both inter- and intraspecifically, which was also the case for the different varieties (Paper II). The variety called

Wilhelm emitted the highest rate of isoprene, which was approx. 3 times larger than for Tora. Tora, which is closer related to Wilhelm in the breeding program compared to Ester and Inger, had the lowest isoprene emission. These results emphasize the importance of making measurements. A preconception would have been that Tora and Wilhelm had similar isoprene emission rates, but they differed the most. Therefore, using emission factors from Tora to scale up isoprene emission from SRPs with Wilhelm (or vice versa), would lead to large errors. On the contrary, Ester and Inger, which were related in the breeding program, showed similar average isoprene and SQT emission rates although the terpene blend differed a bit. Interestingly, all the female varieties (Tora, Ester and Inger) seemed to have lower isoprene emission rates than the male variety (Wilhelm), but no conclusion can be made on the scarce basis from the study in 2017. Hence, more studies involving more male (and female) varieties would be needed to confirm this observation. Further, the high isoprene emission from Wilhelm makes this variety less preferable to grow in large quantities close to sources of NO_x, on account of the risk to produce photochemical pollutions such as O₃ and PAN.

Measurements at different heights for the *Salix* trees showed that sun-adapted leaves emitted higher rates of isoprene, MTs and SQTs (Paper I). Less various compounds of MTs and SQTs were also emitted by the shade-adapted leaves. In fact, no SQTs were seen from the shade-adapted leaves. The isoprene emission rate was approx. twice as high from the more sun-adapted leaves compared to the shaded leaves. Ocimene and α -farnesene, together with isoprene, increased with light intensity. However, this increase for ocimene and α -farnesene was only observed for sun-adapted leaves. None of the other VOCs had any clear correlation with light. On the other hand, emissions of these non-terpenes were higher from the lower canopy height, which indicates that there are other factors than light that influence these emissions. The sun-adapted leaves in the upper part of the canopy lost more of the photosynthesized C as isoprene compared to the shaded leaves. Even though these sun-adapted leaves showed higher net assimilation rates for most of the light levels compared to the shade-adapted leaves, they were less efficient in utilizing C from photosynthesis to primary production because they reemitted more of this C as isoprene.

To better understand how BVOC emissions are developing, stand age of plants is an adequate factor to study. To my knowledge, less focus has been on age even if there exist studies that include this factor. It might not always be easy to know the specific age (without cutting down the trees) in a study when measuring in a forest, since forest ecosystems are a mix of species with different ages. These kinds of studies are better suited for managed plants. Comparing the age and the BVOC emissions between the *Salix* trees showed that saplings and first year growing trees emitted substantially higher rates of other VOCs, probably because they need to strengthen their defense system and make them more resistance to stress. Tora was the only variety that was measured both the first growing year and before harvest (fourth growing year). The results from these measurements showed that isoprene

emission was almost five times as large from the older trees compared to the younger. Contrarily, the emissions of MTs were several times lower from the older trees compared to the younger trees. Only five MTs were seen from the older trees whilst nine were emitted from the younger. This outcome indicates that the age of the plants has an impact on the emissions and younger and mature trees can differ in both their emission rates and compound mixture.

The lack of elevated particle formation at the *Salix* site points out that these trees are not able to emit sufficiently high rates of precursors needed to produce SOAs (Paper III). The low concentration of, e.g., MTs was not enough to generate any particles in the PAM reactor. The MTs constituted only a minor fraction of the BVOC emission. However, compounds that have been reported to cause SOAs, e.g. α -pinene, β -pinene and limonene, were many times higher from the young *Salix* trees. Therefore, it is more likely to find SOAs near saplings and young trees compared to older *Salix* trees. The emission of isoprene was considerably higher from the *Salix* trees compared to the spruce trees (Paper IV). Changing from traditional spruce forest would shift the regional BVOC composition towards more isoprene and less MTs. In addition, a LUCC from annual crops or grasslands to SRPs with *Salix* would also alter the atmospheric concentrations of isoprene, since annual crops and grass are low emitters of isoprene. Consequently, an expansion of SRC fields with willow would need to be located at a sufficient distance far away from anthropogenic pollution, which could otherwise promote the production of O₃ and PAN.

The goal to counteract emissions of GHGs and preventing global warming is far away from completed. Reducing fossil fuel by renewable energy from SRCs could be one part of the solution. However, to estimate the environmental impact on the climate, long-term studies where measurement of CO₂, CH₄, N₂O and aerosols during a complete life span of the plantation (20–25 years) would be needed. Although the results presented in this thesis suggest that BVOC emissions from *Salix* plantation is not jeopardizing air quality, measurements of O₃ near a *Salix* site should also be done since studies mostly model the production of O₃ based on BVOC emission factors. Life cycle assessments of SRPs usually exclude air quality and subsequent health effects, which could be included if there existed representative measurements of, e.g., O₃. Combining leaf scale measurements with PTR-TOF-MS ecosystem scale measurements is needed as well, since these would be an appropriate method to evaluate and improve the emission models, and to investigate the impact from BVOCs if there was a substantial expansion of *Salix* plantations. The outcome from this thesis also highlights that upscaling emissions by modelling is difficult since many factors affect the emission, such as variety, height, age, season and stress. Currently, all these are not represented in the models but may be possible to incorporate in the future.

Acknowledgments

There are many people that I would like to thank and I apologize if I forget anyone.

First of all, the person responsible (a.k.a. partner in crime) for making this to come true is my SUPERvisor, **Thomas Holst**. Thank you so much for believing in me (especially when I did not believe in myself). You have an unprecedented skill in flipping disasters into something constructive and useful, this is a super-skill in particular since I managed to screw up all the time (the big question is, did I ever learn how to pack a truck safely). Without you it would not be possible to finish this.

Ylva van Meeningen and **Min Wang**, thank you very much for all the help, especially with introducing me to the methods. But even more, to welcome me to the BVOC group and taking care of this lost soul. I never had to worry when you were around. Better colleagues are hard to find.

Patrik Vestin, you have always been like a mentor to me. With your guidance, I always got back on the right track and you have probably (unofficially) supervised more people in our department than anyone else.

Leif Klemedtsson and **Paul Miller**, the positive attitude you conveyed is beyond what is possible to measure. I always looked forward to meet you since I knew I became a completely new optimistic person.

Riikka Rinnan, thanks for all the help with organizing the lab analysis. It was always nice to visit you and your team in Copenhagen. Seems like the sun is always shining in that city as long as you are there.

Adam Kristensson, Erik Ahlberg, Stina Ausmeel and Birgitta Svenningsson (a.k.a. the aerosol group), the site never became the same after you left. I really enjoy meeting you and I wished we could have done more collaboration. But I'm still wrestling with the conundrum, who wrote "I need to be washed" in the dirt on the rear window on my mother's car?

David Allbrand, working together with you was like a party. All the problems disappeared. I hope that we can do it again and meeting your family (including the dogs) was an honor.

Geert Hensgens, Olive Niyomubyeyi, Pearl Mzobe, Klas Lucander, Altaaf Mechiche-Alami, Yanzi Yan, Enass Said Al-Kharusi, Sofia Junttila, Joel White, Ehsan Abdolmajidi, Cecilia Olsson, Jalisha Theanutti, Erica Jaakkola and Yun Liu, thank you for all nice memories and activities we did, and for making this department a fun place to work in.

Majia Marushchak, to share the office with you was a lot of fun. Despite your Finish genes, you had a good sense of humor.

Johan Wallerstein, you have always inspired me and you are a true role model.

I also would like to thank **Zhanzhang Cai, Adrian Gustafson, Tetiana Svystun, Fabien Rizinjirabake, Norbert Pirk, Ana Soares, Nitin Chaudhary, Jeppe Ågård Kristensen, Augustus Aturinde, Finn Hedefalk, Oskar Löfgren, George Oriangi, Zhendong Wu, Wilhelm Dubber, Jan Blanke, Niklas Boke-Olén, Abdulhakim M. Abdi, Balathandayuthabani Panneer Selvam, Christian Stiegler, Jing Tang, Ross Petersen** and all the other PhD students that supported me.

Big thanks to **Paul Hedberg, Margareta Hellström, Meelis Mölder, Michal Heliasz, Tobias Biermann, Sachin Patade, Cecilia Akselsson, Jonas Ardö, Mats Lindeskog, Harry Lankreijer, Jonathan Seaquist, Petter Pilesjö, Maj-Lena Linderson, Anna-Maria Jönsson, Stefan Olin, Sadegh Jamali, Jörgen Olofsson, Britta Smångs, Janne Rinne, Abdulghani Hasan, Roger Groth, Per-Erik Fahlén, Oleg Mirzov, Jutta Holst, Rafael Przybyszewski, Ricardo Guillén, Marcin Jackowicz-Korczynski, Jonathan Thiry** and all the rest in the department. One never knows what kind of interesting discussions that pops up when bumping into each other.

Anders Jonsson, Stig Larsson, Sven-Elof Andersson, Sten Segerslätt and Per-Olof Andersson, thank you for all the support and help at the sites, which really facilitated doing the measurements.

Oscar Möllerström and Andreas Petersson, you are the persons that followed me through this journey (read: had to hear me whine all the time). You have been priceless and helped me to focus in a positive manner.

Niclas Arnesen and Malin Persson, thanks for hosting me during my courses in Gothenburg. It was a great memory to spend the time with you.

Lars Axelsson, Enar Karlsson and Trollhättan FIK, thank you for helping me to dispel my thoughts during fieldwork.

Lastly, I thank my family for all their support. Working and training retreats in the forest where you live, helped a lot to cross the finish line.

References

- Alexandersson, H. and Eggertsson Karlström, C., 2001. Temperaturen och nederbörden i Sverige 1961–90: Referensnormaler—utgåva 2 (in Swedish). Meteorologi 99, Swedish Meteorological and Hydrological Institute, Norrköping.
- Ameye, M., Allmann, S., Verwaeren, J., Smaghe, G., Haesaert, G., Schuurink, R. C. and Audenaert, K., 2018. Green leaf volatile production by plants: a meta-analysis. *New Phytol.*, 220, 666–683.
- Ammann, C., Spirig, C., Neftel, A., Steinbacher, M., Komenda, M. and Schaub, A., 2004. Application of PTR-MS for Measurements of Biogenic VOC in a Deciduous Forest. *Int. J. Mass Spectrom.*, 239, 87–101.
- Andersen, R.A., Hamilton-Kemp, T.R., Hildebrand, D.F., McCracken, C.T., Collins, R.W. and Fleming, P.D., 1994. Structure-Antifungal Activity Relationships among Volatile C6 and C9 Aliphatic Aldehydes, Ketones, and Alcohols. *J. Agric. Food Chem.*, 42, 1563–1568.
- Arneth, A., Monson, R. K., Schurgers, G., Niinemets, Ü. and Palmer, P. I., 2008. Why are estimates of global terrestrial isoprene emissions so similar (and why is this not so for monoterpenes)? *Atmos. Chem. Phys.*, 8, 4605–4620.
- Ashmore, M. R., 2005. Assessing the future global impacts of ozone on vegetation. *Plant, Cell and Environ.*, 28, 949–964.
- Ashworth, K., Folberth, G., Hewitt, C. N., and Wild, O., 2012. Impacts of near-future cultivation of biofuel feedstocks on atmospheric composition and local air quality. *Atmos. Chem. Phys.*, 12, 919–939.
- Ashworth, K., Wild, O. and Hewitt, C., 2013. Impacts of biofuel cultivation on mortality and crop yields. *Nature Clim. Change*, 3, 492–496.
- Atkinson, R., 1997. Gas-phase tropospheric reactions of volatile organic compounds: 1. Alkanes and alkenes. *J. Phys. Chem. Ref. Data*, 26, 215–290.
- Atkinson, R. and Arey, J., 2003. Gas-phase tropospheric chemistry of biogenic volatile organic compounds: A review. *Atmos. Environ.*, 37, 197–219.
- Baum, C., Leinweber, P., Weih, M., Lamersdorf, N. and Dimitriou, I., 2009. Effects of short rotation coppice with willows and poplar on soil ecology. *Landbauforschung Volkenrode*, 59, 183–196.
- Beauchamp, J., Wisthaler, A., Hansel, A., Kleist, E., Miebach, M., Niinemets, Ü., Schurr, U. and Wildt, J., 2005. Ozone induced emissions of biogenic VOC from tobacco: relations between ozone uptake and emission of LOX products. *Plant Cell Environ.*, 28, 1334–1343.
- Beltman, J. B., Hendriks, C., Tum, M. and Schaap, M., 2013. The impact of large scale biomass production on ozone air pollution in Europe. *Atmos. Environ.*, 71, 352–363.

- Bonde, I., Kuylenstierna, J., Bäckstrand, K., Eckerberg, K., Kåberger, T., Löfgren, Å., Rummukainen, M. and Sörlin, S., 2020. Report of the Swedish Climate Policy Council. Rapport nr 3, ISBN 978-91-984671-4-7.
- Boucher, O., D. Randall, P. Artaxo, C. Bretherton, G. Feingold, P. Forster, V.-M. Kerminen, Y. Kondo, H. Liao, U. Lohmann, P. Rasch, S.K. Satheesh, S. Sherwood, B. Stevens and X.Y. Zhang, 2013: Clouds and Aerosols. In: *Climate Change 2013: The Physical Science Basis. Contribution of Working Group I to the Fifth Assessment Report of the Intergovernmental Panel on Climate Change* [Stocker, T.F., D. Qin, G.-K. Plattner, M. Tignor, S.K. Allen, J. Boschung, A. Nauels, Y. Xia, V. Bex and P.M. Midgley (eds.)]. Cambridge University Press, Cambridge, United Kingdom and New York, NY, USA.
- Bracho-Nunez, A., Knothe, N.M., Welter, S., Staudt, M., Costa, W.R., Liberato, M.A.R., Piedade, M.T.F. and Kesselmeier, J., 2013. Leaf level emissions of volatile organic compounds (VOC) from some Amazonian and Mediterranean plants. *Biogeosciences*, 10, 5855–5873.
- Brilli, F., Hörtnagl, L., Bamberger, I., Schnitzhofer, R., Ruuskanen, T.M., Hansel, A., Loreto, F. and Wohlfahrt, G., 2012. Qualitative and quantitative characterization of volatile organic compound emissions from cut grass. *Environ. Sci. Technol.*, 46, 3859–3865.
- Bruns, E.A., El Haddad, I., Keller, A., Klein, F., Kumar, N.K., Pieber, S.M., Corbin, J.C., Slowik, J.G., Brune, W.H, Baltensperger, U., et al., 2015. Inter-comparison of laboratory smog chamber and flow reactor systems on organic aerosol yield and composition. *Atmos. Meas. Tech.*, 8, 2315–2332.
- Calfapietra, C., Fares, S., Manes, F., Morani, A., Sgrigna, G. and Loreto, F., 2013. Role of biogenic volatile organic compounds (BVOC) emitted by urban trees on ozone concentration in cities: A review. *Environ. Pollut.*, 183, 71–80.
- Calvete-Sogo, H., Elvira, S., Sanz, J., Gonzalez-Fernandez, I., Garcia-Gomez, H., Sanchez-Martin, L., Alonso, R. and Bermejo-Bermejo, V., 2014. Current ozone levels threaten gross primary production and yield of Mediterranean annual pastures and nitrogen modulates the response. *Atmos. Environ.*, 95, 197–206.
- Capitani, D., Brilli, F., Mannina, L., Proietti, N. and Loreto F., 2009. In situ investigation of leaf water status by portable unilateral nuclear magnetic resonance. *Plant Physiol.*, 149, 1638–1647.
- Chmielewski, F.-M., Heider, S. and Moryson, S., 2013. International phenological observation networks: concept of IPG and GPM. In: Schwartz, M.D. (ed.), *Phenology: An Integrative Environmental Science*, 4th ed., Springer Science+Business Media B.V, 137–153.
- Claeys, M., Wang, W., Ion, A.C., Kourtchev, I., Gelencsér, A. and Maenhaut, W., 2004. Formation of secondary organic aerosols from isoprene and its gas-phase oxidation products through reaction with hydrogen peroxide. *Atmos. Environ.*, 38, 4093–4098.
- Copeland, N., Cape, J.N. and Heal, M.R., 2012. Volatile organic compound emissions from *Miscanthus* and short rotation coppice willow bioenergy crops. *Atmos. Environ.*, 60, 327–335.

- Copolovici, L., Kännaste, A., Pazouki, L. and Niinemets, Ü., 2012. Emissions of green leaf volatiles and terpenoids from *Solanum lycopersicum* are quantitatively related to the severity of cold and heat shock treatments. *J. Plant Physiol.*, 169, 664–672.
- DeCarlo, P.F., Kimmel, J.R., Trimborn, A., Northway, M.J., Jayne, J.T., Aiken, A.C., Gonin, M., Fuhrer, K., Horvath, T., Docherty, K.S., et al., 2006. Field-deployable, high-resolution, time-of-flight aerosol mass spectrometer. *Anal. Chem.*, 78, 8281–8289.
- Dicke, M. and Vet, L.E.M., 1999. Plant-carnivore interactions: evolutionary and ecological consequences for plant, herbivore and carnivore. In: Olf, H., Brown, V.K. and Drent, R.H. (eds) *Herbivores: Between Plants and Predators*. Blackwell Science Oxford, UK, 483–520.
- Dicke, M., van Poecke, R.M.P. and de Boer, J.G., 2003a. Inducible indirect defence of plants: from mechanisms to ecological functions. *Basic Appl. Ecol.*, 4, 27–42.
- Dicke, M., de Boer J.G., Höfte, M. and Rocha-Granados, M.C., 2003b. Mixed blends of herbivore-induced plant volatiles and foraging success of carnivorous arthropods. *Oikos*, 101, 38–48.
- Dombrowski, J.E., Kronmiller, B.A., Hollenbeck, V.G., et al., 2019. Transcriptome analysis of the model grass *Lolium temulentum* exposed to green leaf volatiles. *BMC Plant Biol.*, 19, 1–17.
- Emberson, L., Pleijel, H., Ainsworth, E.A., Berg, M.V.D., Ren, W., Osborne, S., Mills, G., Pandey, D., Dentener, F., Büker, P., et al., 2018. Ozone effects on crops and consideration in crop models. *Eur. J. Agron.*, 100, 19–34.
- Ehn, M., Thornton, J.A., Kleist, E., Sipilä, M., Junninen, H., Pullinen, I., Springer, M., Rubach, F., Tillmann, R., Lee, B., Lopez-Hilfiker, F., Andres, S., Acir, I.-H., Rissanen, M., Jokinen, T., Schobesberger, S., Kangasluoma, J., Kontkanen, J., Nieminen, T., Kurtén, T., Nielsen, L.B., Jørgensen, S., Kjaergaard, H.G., Canagaratna, M., Maso, M.D., Berndt, T., Petäjä, T., Wahner, A., Kerminen, V.-M., Kulmala, M., Worsnop, D.R., Wildt, J. and Mentel, T.F., 2014. A large source of low-volatility secondary organic aerosol. *Nature*, 506, 476–479.
- European Commission, 2014. A policy framework for climate and energy in the period from 2020 up to 2030. Brussels, European commission
- Evans, R.C., Tingey, D.T. and Gumpertz, M.L., 1985. Interspecies variation in terpenoid emission rates from Engelmann and Sitka Spruce seedlings. *Forest Sci.*, 13, 132–142.
- Fan, J., Wang, Y., Rosenfeld, D. and Liu, X., 2016. Review of aerosol-cloud interactions: Mechanisms, significance, and challenges. *J. Atmos. Sci.*, 73, 4221–4252.
- Fann, N., Nolte, C.G., Dolwick, P., Spero, T.L., Curry Brown, A., Phillips S. and Anenberg, S., 2015. The geographic distribution and economic value of climate change-related ozone health impacts in the United States in 2030. *J. Air Waste Manag. Assoc.*, 65, 570–580.
- Fehsenfeld, F., Calvert, J., Fall, R., Goldan, P., Guenther, A. B., Hewitt, C. N., et al., 1992. Emissions of volatile organic compounds from vegetation and the implications for atmospheric chemistry. *Global Biogeochem. Cycles*, 6, 389–430.
- Folberth, G. A., Hauglustaine, D. A., Lathièrre, J. and Brocheton, F., 2005. Impact of biogenic hydrocarbons on tropospheric chemistry: results from a global chemistry-climate model. *Atmos. Chem. Phys. Discuss.*, 5, 10517–10612.

- Folberth, G. A., Hauglustaine, D. A., Lathière, J. and Brocheton, F., 2006. Interactive chemistry in the Laboratoire de Météorologie Dynamique general circulation model: model description and impact analysis of biogenic hydrocarbons on tropospheric chemistry. *Atmos. Chem. Phys.*, 6, 2273–2319.
- Fredga, K., Danell, K., Frank, H., Hedberg, D. and Kullander, S., 2008. Bioenergy – Opportunities and constraints. Energy Committee Report, June 2008, Kungliga Vetenskapsakademin.
- Fumagalli, I., Gimeno, B.S., Velissariou, D., De Temmerman, L. and Mills, G., 2001. Evidence of ozone-induced adverse effects on crops in the Mediterranean region. *Atmos. Environ.*, 35, 2583–2587.
- Grelle, A., Aronsson, P., Weslien, P., Klemetsson, L. and Lindroth, A., 2007. Large carbon-sink potential by Kyoto forests in Sweden – a case study on willow plantations. *Tellus B Chem. Phys. Meteorol.*, 59, 910–918.
- Guenther, A.B., 1997. Seasonal and spatial variations in natural volatile organic compound emissions. *Ecol. Appl.*, 7, 34–45.
- Guenther, A.B., Monson, R.K. and Fall, R., 1991. Isoprene and monoterpene emission rate variability: Observations with eucalyptus and emission rate algorithm development. *J. Geophys. Res.*, 96, 10799–10808.
- Guenther, A.B., Zimmerman, P., Harley, P.C., Monson, R.K. and Fall, R., 1993. Isoprene and monoterpene emission rate variability: Model evaluations and sensitivity analyses. *J. Geophys. Res.*, 98, 12609–12617.
- Guenther, A., Hewitt, C.N., Erickson, D., Fall, R., Geron, C., Graedel, T., Harley, P., Klinger, L., Lerdau, M., McKay, W.A., Pierce, T., Scholes, B., Steinbrecher, R., Tallamraju, R., Taylor, J. and Zimmerman, P., 1995. A global model of natural volatile organic compound emissions. *J. Geophys. Res.*, 100, 8873–8892.
- Guenther, A., 2002. The contribution of reactive carbon emissions from vegetation to the carbon balance of terrestrial ecosystems. *Chemosphere*, 49, 837–844.
- Guenther, A. B., Karl, T., Harley, P., Wiedinmyer, C., Palmer, P. I. and Geron, C., 2006. Estimates of global terrestrial isoprene emissions using MEGAN (Model of Emissions of Gases and Aerosols from Nature). *Atmos. Chem. Phys.*, 6, 3181–3210.
- Guenther, A. B., Jiang, X., Heald, C. L., Sakulyanontvittaya, T., Duhl, T., Emmons, L. K. and Wang, X., 2012. The Model of Emissions of Gases and Aerosols from Nature version 2.1 (MEGAN2.1): an extended and updated framework for modeling biogenic emissions. *Geosci. Model Dev.*, 5, 1471–1492.
- Gupta, S., Tirpak, D.A., Burger, N., Gupta, J., Höhne, N., Boncheva, A.I., Kanoan, G.M., Kolstad, C., Kruger, J.A., Michaelowa, A., Murase, S., Pershing, J., Saijo, T. and Sari, A. 2007: Policies, Instruments and Co-operative Arrangements. In *Climate Change 2007: Mitigation. Contribution of Working Group III to the Fourth Assessment Report of the Intergovernmental Panel on Climate Change* [B. Metz, O.R. Davidson, P.R. Bosch, R. Dave, L.A. Meyer (eds)], Cambridge University Press, Cambridge, United Kingdom and New York, NY, USA.
- Haagen-Smit, A.J., 1952. Chemistry and physiology of Los-Angeles smog. *Ind. Eng. Chem. Res.*, 44, 1342–1346.

- Hakola, H., Rinne, J. and Laurila, T., 1998. The hydrocarbon emission rates of tea-leaved willow (*Salix phylicifolia*), silver birch (*Betula pendula*) and European aspen (*Populus tremula*). *Atmos. Environ.*, 32, 1825–1833.
- Hakola, H., Rinne, J. and Laurila, T., 1999. The VOC Emission Rates of Boreal Deciduous Trees. European Commission: Biogenic VOC emissions and photochemistry in the boreal regions of Europe - Biphorep, 3, 21–28.
- Hansel, A., Jordan, A., Holzinger, R., Prazeller, P., Vogel, W. and Lindinger, W., 1995. Proton transfer reaction mass spectrometry: on-line trace gas analysis at the ppb level. *Int. J. Mass Spectrom. Ion Processes*, 149/150, 605–619.
- Hatanaka, A., 1993. The biogeneration of green odour by green leaves. *Phytochemistry*, 34, 1201–1218.
- Helmig, D., Ortega, J., Duhl, T., Tanner, D., Guenther, A., Harley, P., Wiedinmyer, C., Milford, J. and Sakulyanontvittaya, T., 2007. Sesquiterpene Emissions from Pine Trees – Identifications, Emission Rates and Flux Estimates for the Contiguous United States. *Environ. Sci. Technol.*, 41, 1545–1553.
- Hildebrand, D. F., 1989. Lipoxygenases. *Physiol. Plant.*, 76, 249–253.
- Hillier, J., Whittaker, C., Dailey, A.G., Aylott, M., Casella, E., Richter, G.M., Riche, A., Murphy, R., Taylor, G. and Smith, P., 2009. Greenhouse gas emissions from four bio-energy crops in England and Wales: integrating spatial estimates of yield and soil C balance in life cycle analyses. *GCB Bioenergy*, 1, 267–281.
- Hoffmann, T., Odum, J. R., Bowman, F., Collins, D., Klockow, D., Flagan, R. C. and Seinfeld, J. H., 1997. Formation of organic aerosols from the oxidation of biogenic hydrocarbons. *J. Atmos. Chem.*, 26, 189–222.
- Hollsten, R., Arkelöv, O. and Ingelman, G., 2013. Handbok för Salixodlare (in Swedish), Jordbruksverket, 2:a utgåvan
- Holzinger, R., 2015. PTRwid: A new widget tool for processing PTR-TOF-MS data. *Atmos. Meas. Tech.*, 8, 3903–3922.
- Holzinger, R., Lee, A., Paw U, K.T. and Goldstein, A. H., 2005. Observations of oxidation products above a forest imply biogenic emissions of very reactive compounds. *Atmos. Chem. Phys.*, 5, 67–75.
- Hough, A. M. and Johnson, C. E., 1991. Modelling the role of nitrogen oxides, hydrocarbons and carbon monoxide in the global formation of tropospheric oxidants. *Atmos. Environ.*, 25A, 1819–1835.
- Humphrey, A.J. and Beale, M.H., 2006. Terpenes. In: Crozier A., Clifford M.N. and Ashihara, H. (eds). *Plant secondary metabolites, occurrence, structure and role in the human diet*. Blackwell Publishing Ltd, Oxford, 47–101.
- IPCC, 2014: *Climate Change 2014: Synthesis Report*. Contribution of Working Groups I, II and III to the Fifth Assessment Report of the Intergovernmental Panel on Climate Change [Core Writing Team, R.K. Pachauri and L.A. Meyer (eds.)]. IPCC, Geneva, Switzerland, 151 pp.

- IPCC, 2018: Summary for Policymakers. In: Global warming of 1.5°C. An IPCC Special Report on the impacts of global warming of 1.5°C above pre-industrial levels and related global greenhouse gas emission pathways, in the context of strengthening the global response to the threat of climate change, sustainable development, and efforts to eradicate poverty [V. Masson-Delmotte, P. Zhai, H. O. Pörtner, D. Roberts, J. Skea, P. R. Shukla, A. Pirani, W. Moufouma-Okia, C. Péan, R. Pidcock, S. Connors, J. B. R. Matthews, Y. Chen, X. Zhou, M. I. Gomis, E. Lonnoy, T. Maycock, M. Tignor, T. Waterfield (eds.)]. World Meteorological Organization, Geneva, Switzerland, 32 pp.
- IPCC, 2021: Summary for Policymakers. In: *Climate Change 2021: The Physical Science Basis. Contribution of Working Group I to the Sixth Assessment Report of the Intergovernmental Panel on Climate Change* [Masson-Delmotte, V., P. Zhai, A. Pirani, S. L. Connors, C. Péan, S. Berger, N. Caud, Y. Chen, L. Goldfarb, M. I. Gomis, M. Huang, K. Leitzell, E. Lonnoy, J.B.R. Matthews, T. K. Maycock, T. Waterfield, O. Yelekçi, R. Yu and B. Zhou (eds.)]. Cambridge University Press. In Press.
- Isebrands, J., Guenther, A., Harley, P., et al., 1999. Volatile organic compound emission rates from mixed deciduous and coniferous forests in Northern Wisconsin, USA. *Atmos. Environ.*, 33, 2527–2536.
- Isebrands, J.G. and Richardson, J., 2014. Introduction. In: Isebrands, J.G., Richardson, J. (eds.), *Poplars and Willow – Trees for Society and the Environment*. The Food and Agriculture Organization of United States (FAO) and CABI, ISBN (FAO): 978 92 5 107185 4, ISBN (CABI): 978 1 78064 108 9, 1–7.
- Jiang, Y., Ye, J., Linda-Liisa Veromann, L.-L. and Niinemets, Ü., 2016. Scaling of photosynthesis and constitutive and induced volatile emissions with severity of leaf infection by rust fungus (*Melampsora larici-populina*) in *Populus balsamifera* var. *suaveolens*. *Tree Physiol.*, 36, 856–872.
- Joó, É., Dewulf, J., Amelynck, C., Schoon, N., Pokorska, O., Šimpraga, M., Steppe, K., Aubinet, M. and Van Langenhove, H., 2011. Constitutive versus heat and biotic stress induced BVOC emissions in *Pseudotsuga menziesii*. *Atmos. Environ.*, 45, 3655–3662.
- Kanakidou, M., Seinfeld, J. H., Pandis, S. N., Barnes, I., Dentener, F. J., Facchini, M. C., Van Dingenen, R., Ervens, B., Nenes, A., Nielsen, C. J., Swietlicki, E., Putaud, J. P., Balkanski, Y., Fuzzi, S., Horth, J., Moortgat, G. K., Winterhalter, R., Myhre, C. E. L., Tsigaridis, K., Vignati, E., Stephanou, E. G. and Wilson, J., 2005. Organic aerosol and global climate modelling: a review. *Atmos. Chem. Phys.*, 5, 1053–1123
- Kaplan, J. O., Folberth, G. and Hauglustaine, D. A., 2006. Role of methane and biogenic volatile organic compound sources in late glacial and Holocene fluctuations of atmospheric methane concentrations. *Glob. Biogeochem. Cycles*, 20, 1–16.
- Karl, M., Guenther, A., Köble, R., Leip, A. and Seufert, G., 2009. A new European plant specific emission inventory of biogenic volatile organic compounds for use in atmospheric transport models. *Biogeosciences*, 6, 1059–1087.
- Karlsson, T., Rinnan, R. and Holst, T., 2020. Variability of BVOC Emissions from Commercially Used Willow (*Salix* spp.) Varieties. *Atmosphere-Basel*, 11, 346.

- Karp, A., Haughton, A.J., Bohan, D.A., et al., 2009. Perennial energy crops: implications and potential. In: Winter, M., Lobley, M. (eds.), *What is Land For? The Food, Fuel and Climate Change Debate*. London, UK: Earthscan. 3–71.
- Kesselmeier, Ciccioli, P., J., Kuhn, U., et al., 2002. Volatile organic compound emissions in relation to plant carbon fixation and the terrestrial carbon budget. *Global Biogeochem. Cycles*, 16, 73-1–73-9.
- Kesselmeier, J., Schäfer, L., Ciccioli, P., Brancaleoni, E., Cecinato, A., Frattoni, M., Foster, P., Jacob, V., Denis, J., Fugit, J.-L., Dutaur, L., and Torres, L., 1996. Emission of monoterpenes and isoprene from a Mediterranean oak species *Quercus ilex* L. measured within the BEMA (Biogenic Emissions in the Mediterranean Area) project. *Atmos. Environ.*, 30, 1841–1850.
- Kesselmeier, J. and Staudt, M., 1999. Biogenic volatile organic compounds (VOC): An overview on emission, physiology and ecology. *J. Atmos. Chem.*, 33, 23–88.
- Kim, J.C., Kim, K.J., Kim, D.S. and Han, J.S., 2005. Seasonal variations of monoterpene emissions from coniferous trees of different ages in Korea. *Chemosphere*, 59, 1685–1696.
- Kimming, M., Sundberg, C., Nordberg, Å., Baky, A., Bernesson, S., Norén, O. and Hansson, P.A., 2011. Biomass from agriculture in small-scale combined heat and power plants - a comparative life cycle assessment. *Biomass Bioenergy*, 35, 1572–1581.
- Kleinman, L., Daum, P.H., Imre, D., Lee, Y.-N., Nunnermacker, L.J., Springston, S., Weinstein-Lloyd, J. and Rudolph, J., 2002. Ozone production rate and hydrocarbon reactivity in 5 urban areas: A cause of high ozone concentration in Houston. *Geophys. Res. Lett.*, 29, 105-1–105-4.
- Kuehn, B.M., 2014. WHO: More Than 7 Million Air Pollution Deaths Each Year. *JAMA.*, 311, 1486.
- Kulmala, M., Suni, T., Lehtinen, K.E.J., Maso, M.D., Boy, M., Reissell, A., Rannik, Ü., Aalto, P., Keronen, P., Hakola, H., et al., 2004. A new feedback mechanism linking forests, aerosols, and climate. *Atmos. Chem. Phys. Discuss.*, 4, 557–562.
- Kuzma, J. and Fall, R., 1993. Leaf isoprene emission rate is dependent on leaf development and the level of isoprene synthase. *Plant Physiol.*, 101, 435–440.
- Kägi, T., Deimling, S., Knuchel, R. F., Gaillard, G., Hölscher, T. and Müller-Sämman, K., 2008. Environmental impacts of annual and perennial energy crops compared to a reference food crop rotation. Empowerment of the rural actors: a renewal of farming systems perspectives: 8th European IFSA Symposium, Clermont-Ferrand, France, 6–10 July 2008, 675–681.
- König, G., Brunda, M., Puxbaum, H., Hewitt, C. N., Duckham, S. C. and Rudolph, J., 1995. Relative contribution of oxygenated hydrocarbons to the total biogenic VOC emissions of selected mid-European agricultural and natural plant species. *Atmos. Environ.*, 29, 861–874.
- Landberg, T. and Greger, M., 1996. Differences in uptake and tolerance to heavy metals in *Salix* from unpolluted and polluted areas. *Appl. Geochem.*, 11, 175–180.
- Landrigan, P.J., Fuller, R., Acosta, N.J.R., Adeyi, O., Arnold, R., Basu, N., B., et al., 2017. *The Lancet Commission on pollution and health*. 1–51.

- Lange, B.M., Rujan, T., Martin, W. and Croteau, R., 2000. Isoprenoid biosynthesis: the evolution of two ancient and distinct pathways across genomes. *Proc. Natl. Acad. Sci. USA*, 97, 13172–13177.
- Laothawornkitkul, J., Taylor, J.E., Paul, N. and Hewitt, C.N., 2009. Biogenic volatile organic compounds in the Earthsystem. *New Phytol.*, 183, 27–51.
- Lichtenthaler, H.K., 1999. The 1-deoxy-D-xylulose-5-phosphate pathway of isoprenoid biosynthesis in plants. *Annu. Rev. Plant Physiol.*, 50, 47–65.
- Lim, J.H., Kim, J.C., Kim, K.J., Son, Y.S., Sunwoo, Y. and Han, J.S., 2008. Seasonal variations of monoterpene emissions from *Pinus densiflora* in East Asia. *Chemosphere*, 73, 470–478.
- Lindinger, W., Hansel, A. and Jordan, A., 1998. On-line monitoring of volatile organic compounds at pptv levels by means of Proton-Transfer-Reaction Mass Spectrometry (PTR-MS) Medical applications, food control and environmental research. *Int. J. Mass Spectrom. Ion Process*, 173, 191–241.
- Lindgaard, K.N., Adams, P.W., Holley, M., Lamley, A., Henriksson, A., Larsson, S., von Engelbrechten, H.G., Esteban Lopez, G. and Pisarek, M., 2016. Short rotation plantations policy history in Europe: lessons from the past and recommendations for the future. *Food and energy security*, 5, 125–152.
- Loreto, F., Pinelli, P., Brancaleoni, E. and Ciccioli, P., 2004. ¹³C labelling reveals chloroplastic and extrachloroplastic pools of dimethylallyl pyrophosphate and their contribution to isoprene formation. *Plant Physiol.*, 135, 1903–1907.
- Loreto, F., et al., 2006. On the induction of volatile organic compound emissions by plants as consequence of wounding or fluctuations of light and temperature. *Plant Cell Environ.*, 29, 1820–1828.
- Loreto, F. and Schnitzler J-P., 2010. Abiotic stresses and induced BVOCs. *Trends Plant Sci.*, 15, 154–166.
- Lovelock, J.E., 1977. PAN in the natural environment, its possible significance in the epidemiology of skin cancer. *Ambio*, 6, 131–133.
- Llusià, J. and Peñuelas, J., 1998. Changes in terpene content and emission in potted Mediterranean Woody plants under severe drought. *Can. J. Bot.*, 76, 1366–1373.
- Llusià, J. and Peñuelas, J., 2001. Emission of volatile organic compounds by apple trees in response to spider mite attack and attraction of predatory mites. *Experimental and Applied Acarology*, 25, 65–77.
- van Meeningen, Y., et al., 2017. Isoprenoid emission variation of Norway spruce across a European latitudinal transect. *Atmos. Environ.*, 170, 45–57.
- McCracken, A.R. and Johnston, C.R., 2015. Potential for wastewater management using energy crops. *Sci. Papers, Ser. Manag. Econom. Eng. Agric. Rural Dev.*, 15, 275–284.
- Meers, E., Vandecasteele, B., Ruttens, A., Vangronsveld, J. and Tack, F.M.G., 2007. Potential of five willow species (*Salix* spp.) for phytoextraction of heavy metals. *Environ. Exp. Bot.*, 60, 57–68.
- Merk, L., Kloos, M., Schönwitz, R. and Ziegler, H., 1988. Influence of various factors on quantitative composition of leaf monoterpenes of *Picea abies* (L.) Karst. *Trees*, 2, 45–51.

- Misztal, P.K., Hewitt, C.N., Wildt, J., Blande, J.D., Eller, A., Fares, S., Gentner, D., Gilman, J., Graus, M., Greenberg, J., et al., 2015. Atmospheric benzenoid emissions from plants rival those from fossil fuels. *Sci. Rep.*, 5, 12064.
- Mleczek, M., Rutkowski, P., Rissmann, I., Kaczmarek, Z., Golinski, P., Szentner, K., Strażyńska, K. and Stachowiak, A., 2010. Biomass productivity and phytoremediation potential of *Salix alba* and *Salix viminalis*. *Biomass Bioenergy*, 34, 1410–1418.
- Monks, P. S., Granier, C., Fuzzi, S., Stohl, A., Williams, M. L., et al., 2010. Atmospheric composition change - global and regional air quality. *Atmos. Environ.*, 43, 5268–5350.
- Monson, R.K. and Fall, R., 1989. Isoprene emission from aspen leaves. *Plant Physiol.*, 90, 267–274.
- Monson, R.K., Harley, P.C., Litvak, M.E., Wildermuth, M., Guenther, A.B., Zimmerman, P.R. and Fall, R., 1994. Environmental and developmental controls over the seasonal pattern of isoprene emission from aspen leaves. *Oecologia*, 99, 260–270.
- Monson, R.K., Jaeger, C.H., Adams, W., Driggers, E., Silver, G. and Fall, R., 1992. Relationships among isoprene emission rate, photosynthesis rate, and isoprene synthase activity, as influenced by temperature. *Plant Physiol.*, 92, 1175–1180.
- Morrison, E. C., Drewer, J. and Heal, M.R., 2016. A comparison of isoprene and monoterpene emission rates from the perennial bioenergy crops short-rotation coppice willow and *Miscanthus* and the annual arable crops wheat and oilseed rape. *GCB. Bioenergy*, 8, 211–225.
- Mutzel, A., Rodigast, M., Iinuma, Y., Böge, O. and Herrmann, H. 2016. Monoterpene SOA – Contribution of first-generation oxidation products to formation and chemical composition, *Atmos. Environ.* 130, 136–144.
- Müller, J. F., 1992. Geographical distribution and seasonal variation of surface emissions and deposition velocities of atmospheric trace gases. *J. Geophys. Res.*, 97, 3787–3804.
- Müller, M., Graus, M., Ruuskanen, T. M., Schnitzhofer, R., Bamberger, I., Kaser, L., Titzmann, T., Hörtnagl, L., Wohlfahrt, G., Karl, T. and Hansel, A., 2010. First eddy covariance flux measurements by PTR-TOF. *Atmos. Meas. Tech.*, 3, 387–395.
- Niinemets, Ü., Loreto F. and Reichstein, M., 2004. Physiological and physico-chemical controls on foliar volatile organic compound emissions. *Trends Plant Sci.*, 9, 180–186.
- Niinemets, Ü., Copolovici, L. and Hüve, K., 2010. High within-canopy variation in isoprene emission potentials in temperate trees: implications for predicting canopy-scale isoprene fluxes. *J. Geophys. Res.-Biogeo.*, 115, G04029
- Niinemets, Ü. and Monson, R. K., 2013. Carbon Utilization and Dry Matter Production. In: *Biology, Controls and Models of Tree Volatile Organic Compound Emissions*, volume 5, *Tree Physiol.*, Springer Dordrecht Heidelberg New York London, ISBN 978-94-007-6605-121–46.
- Nuñez, T. and Pio, C., 2001. Emission of volatile organic compounds from Portuguese eucalyptus forests. *Chemosphere – Global Change Science*, 3, 239–248.

- O'Dowd, C. D., Jimenez, J. L., Bahreini, R., Flagan, R. C., Seinfeld, J. H., Hämeri, K., Pirjola, L., Kulmala, M., Jennings, S. G. and Hoffmann, T., 2002. Marine aerosol formation from biogenic iodine emissions. *Nature*, 417, 497–501.
- Olofsson, M., Ek-Olausson, B., Ljungström, E. and Langer, S., 2003. Flux of organic compounds from grass measured by relaxed eddy accumulation technique. *J. Environ. Monitor.*, 5, 963–970.
- Olofsson, M., Ek-Olausson, B., Jensen N.O., Langer S. and Ljungström E., 2005. The flux of isoprene from a willow plantation and the effect on local air quality. *Atmos. Environ.*, 39, 2061–2070.
- Ortega, J. and Helmig, D., 2008. Approaches for quantifying reactive and low-volatility biogenic organic compound emissions by vegetation enclosure techniques – Part A. *Chemosphere*, 72, 343–364.
- Owen, S. M. and Hewitt C. N., 2000. Extrapolating branch enclosure measurements to estimates of regional scale biogenic VOC fluxes in the north-western Mediterranean basin. *J. Geophys. Res.*, 105, 11573–11583.
- Paasonen, P., Asmi, A., Petäjä, T., Kajos, M.K., Äijälä, M., Junninen, H., Holst, T., Abbatt, J.P.D., Arneth, A., Birmili, W., van der Gon, H.D., Hamed, A., Hoffer, A., Laakso, L., Laaksonen, A., Leaitch, W.R., Plass-Dülmer, C., Pryor, S.C., Räisänen, P., Swietlicki, E., Wiedensohler, A., Worsnop, D.R., Kerminen, V.-M. and Kulmala, M., 2013. Warming-induced increase in aerosol number concentration likely to moderate climate change. *Nat. Geosci.*, 6, 438–442.
- Paiva, N.L., 2000. An introduction to the biosynthesis of chemicals used in plant-microbe communication. *J. Plant Growth Regul.*, 19, 131–143.
- Palm, B.B., Sá, S.S.D., Day, D.A., Campuzano-Jost, P., Hu, W., Seco, R., Sjostedt, S.J., Park, J.H., Guenther, A.B., Kim, S., et al., 2018. Secondary organic aerosol formation from ambient air in an oxidation flow reactor in central Amazonia. *Atmos. Chem. Phys. Discuss.*, 18, 467–493.
- Palo, T., 1984. Distribution of birch (*Betula* SPP.), willow (*Salix* SPP.), and poplar (*Populus* SPP.) secondary metabolites and their potential role as chemical defense against herbivores. *J. Chem. Ecol.*, 10, 499–520.
- Pandis, S.N., Harley, R.A., Cass, G.R. and Seinfeld, J.H., 1992. Secondary organic aerosol formation and transport. *Atmos. Environ.*, 26A, 2269–2282.
- Pandis, S.N., Paulson, S.E., Seinfeld, J.H., and Flagan, R.C., 1991. Aerosol formation in the photooxidation of isoprene and β -pinene. *Atmos. Environ.*, 25A, 997–1008.
- Paulson, S.E., Pandis, S.N., Baltensperger, U., Seinfeld, J.H., Flagan, R.C., Palen, E.J., Allen, D.T., Schaffner, C., Giger, W. and Protmann, A., 1990. Characterization of photochemical aerosols from biogenic hydrocarbons. *J. Aerosol Sci.*, 21, 245–248.
- Paulson, S. E., and Orlando, J. J., 1996. The reactions of ozone with alkenes: An important source of HO_x in the boundary layer. *Geophys. Res. Lett.*, 23, 3727–3730.
- Peñuelas, J. and Filella, I., 2001. Phenology: responses to a warming world. *Science*, 294, 793–795.
- Peñuelas, J. and Llusià, J., 2003. BVOCs: plant defence against climate warming?. *Trends Plant Sci.* 8, 105–109.
- Peñuelas, J., et al., 2009. Phenology feedbacks on climate change. *Science*, 324, 887–888.

- Peñuelas, J. and Staudt, M., 2010. BVOCs and global change. *Trends Plant Sci.*, 15, 133–144.
- Pétron, G., Harley, P., Greenberg, J. and Guenther, A., 2001. Seasonal temperature variations influence isoprene emission. *Geophys. Res. Lett.*, 28, 1707–1710.
- Pike, R. C. and Young, P. J., 2009. How plants can influence tropospheric chemistry: the role of isoprene emissions from the biosphere. *Weather*, 64, 12, 332–336.
- Pio, C., Nunes T. and Brito, S., 1993. Volatile hydrocarbon emissions from common and native species of vegetation in Portugal. In: Slanina, J., Angeletti G., Beilke, S. (eds.), *General Assessment of Biogenic Emissions and Deposition of Nitrogen Compounds, Sulphur compounds and Oxidants in Europe*, CEC Air Pollution Research Report 47, Brussels, Belgium, Guyot SA, 291–298.
- Pope, C. A., and Dockery, D. W., 2006. Health effects of fine particulate air pollution: Lines that connect. *J. Air Waste Manag. Assoc.*, 56, 709–742.
- Possell, M. and Loreto, F., 2013. The role of volatile organic compounds in plant resistance to abiotic stresses: responses and mechanisms. In: Niinemets Ü. and Monson R.K. (eds), *Biology, Controls and Models of Tree Volatile Organic Compound Emissions, Tree physiology 5*, Springer, Dordrecht Heidelberg New York London, 209–235.
- Ragauskas, A.J., Williams, C.K., Davison B.H., Britovsek, G., Cairney, J., Eckert, C.A, Frederick, W.J., Hallett, J.P., Leak, D.J., Liotta, C.L., Mielenz, J.R., Murphy, R., Templer, R. and Tschaplinski, T., 2006. The path forward for biofuels and biomaterials. *Science*, 311, 484–489.
- Rinne J., Tuovinen, J.P., Laurila, T., Hakola, H., Aurela, M. and Hypén, H., 2000. Measurements of isoprene and monoterpene fluxes by a gradient method above a northern boreal forest. *Agric. For. Meteorol.*, 102, 25–37.
- Rinne, J., Bäck, J. and Hakola, H., 2009. Biogenic volatile organic compound emissions from the Eurasian taiga: current knowledge and future directions. *Boreal Environ. Res.*, 14, 807–826.
- Rohmer, M., 1999. The discovery of a mevalonate-independent pathway for isoprenoid biosynthesis in bacteria, algae and higher plants. *Nat. Prod. Rep.*, 16, 565–574.
- Roselle, S. J., Pierce, T. E. and Schere, K. L., 1991. The sensitivity of regional ozone modeling to biogenic hydrocarbons. *J. Geophys. Res.*, 96, 7371–7394.
- Rosenfeld, D., Sherwood, S., Wood, R. and Donner, L., 2014. Climate effects of aerosol-cloud interactions. *Science*, 343, 379–380.
- Ruuskanen, T. M., Müller, M., Schnitzhofer, R., Karl, T., Graus, M., Bamberger, et al., 2011. Eddy covariance VOC emission and deposition fluxes above grassland using PTR-TOF. *Atmos. Chem. Phys.*, 11, 611–625.
- Ryerson, T.B., Trainer, M., Holloway, J.S., Parrish, D.D., Huey, L.G., Sueper, D.T., Frost, G.J., Donnelly, S.G., Schauffler, S., Atlas, E., et al., 2001. Observations of Ozone Formation in Power Plant Plumes and Implications for Ozone Control Strategies. *Science*, 292, 719–723.
- Sakaki T., 1998. Photochemical oxidants: toxicity. In: De Kok LJ, Stulen I, eds. *Responses of plant metabolism to air pollution and global change*. Leiden, The Netherlands: Backhuys Publishers, 117–129.

- Sanadze, G.A., 1956. Emission of gaseous organic substance from plants. *Repertuar Akademiia Nauk Gruzinskoi SSR*, 17, 429–433.
- Schnitzler, J-P., Graus, M., Kreuzwieser, J., Heizmann, U., Rennenberg, H., Wisthaler, A. and Hansel, A. 2004. Contribution of different carbon sources to isoprene biosynthesis in poplar leaves. *Plant Physiol.*, 135, 152–160.
- Seinfeld, J.H., Bretherton, C., Carslaw, K.S., et al., 2016. Improving our fundamental understanding of the role of aerosol-cloud interactions in the climate system. *Proc. Natl. Acad. Sci. USA*, 113, 5781–5790.
- Sharkey, T.D., Loreto, F. and Delwiche, C.F., 1991. High carbon dioxide and sun/shade effects on isoprene emission from oak and aspen tree leaves. *Plant Cell Environ.*, 14, 333–338.
- Sharkey, T. D. and F. Loreto., 1993. Water stress, temperature, and light effects on the capacity for isoprene emission and photosynthesis of kudzu leaves. *Oecologia*, 95, 328–333.
- Sharkey, T.D., Singsaas, E.L., Vanderveer, P.J. and Geron, C.D., 1996. Field measurements of isoprene emission from trees in response to temperature and light. *Tree Physiol.* 16, 649–654.
- Sitch S., Cox P.M., Collins W.J. and Huntingford C., 2007. Indirect radiative forcing of climate change through ozone effects on the land-carbon sink. *Nature*, 448, 791–794.
- Skogsdata, 2020. Skogsdata 2020 – Aktuella uppgifter om de svenska skogarna från SLU Riksskogstaxering, Tema: Den döda veden (in Swedish). Institutionen för skoglig underhållning, SLU Umeå, ISSN 0280-0543.
- SOU 2007:36. Bioenergi från Jordbruket—en Växande Resurs; Statens Offentliga Utredningar; Edita Sverige AB, Stockholm, Sweden, 2007. ISBN 978-91-38-22751-0
- Spracklen, D.V., Bonn, B. and Carslaw, K.S., 2008. Boreal forests, aerosols and the impacts on clouds and climate. *Phil. Trans. R. Soc. A.*, 366, 4613–4626.
- Staudt, M., Mir, C., Joffre, R., Rambal, S., Bonin, A., Landais, D. and Lumaret, R., 2004. Isoprenoid emissions of *Quercus* spp. (*Q. suber* and *Q. ilex*) in mixed stands contrasting in interspecific genetic introgression. *New Phytol.*, 163, 573–584.
- Staudt, M., et al., 2008. Do volatile organic compound emissions of Tunisian cork oak populations originating from contrasting climatic conditions differ in their responses to summer drought?. *Can. J. For. Res.* 38, 2965–2975.
- Steinbrecher, R., Schfirmann, W., Schreiner, A. M. and Ziegler, H., 1993. Terpenoid emissions from common oak (*Quercus robur* L.) and Norway spruce (*Picea abies* L. Karst.). In *General Assessment of Biogenic Emissions and Deposition of Nitrogen Compounds, Sulphur Compounds and Oxidants in Europe*, CEC Air Pollution Research Report 47 (edited by Slanina J., Angeletti G. and Beilke S.), ISBN 2-87263-095-3, E. Guyot SA, Brussels, 251–259.
- Stettler, R.F., 2009. The farers tree. In: Stettler, R.F., *Cottonwood and the River of Time: On Trees, Evolution and Society*. University of Washington Press, Seattle, Washington; London, 161–172.

- Stocker, T.F., D. Qin, G.-K. Plattner, L.V. Alexander, S.K. Allen, N.L. Bindoff, F.-M. Bréon, J.A. Church, U. Cubasch, S. Emori, P. Forster, P. Friedlingstein, N. Gillett, J.M. Gregory, D.L. Hartmann, E. Jansen, B. Kirtman, R. Knutti, K. Krishna Kumar, P. Lemke, J. Marotzke, V. Masson-Delmotte, G.A. Meehl, I.I. Mokhov, S. Piao, V. Ramaswamy, D. Randall, M. Rhein, M. Rojas, C. Sabine, D. Shindell, L.D. Talley, D.G. Vaughan and S.-P. Xie, 2013. Technical Summary. In: *Climate Change 2013: The Physical Science Basis. Contribution of Working Group I to the Fifth Assessment Report of the Intergovernmental Panel on Climate Change* [Stocker, T.F., D. Qin, G.-K. Plattner, M. Tignor, S.K. Allen, J. Boschung, A. Nauels, Y. Xia, V. Bex and P.M. Midgley (eds.)]. Cambridge University Press, Cambridge, United Kingdom and New York, NY, USA.
- Sun, J., Feng, Z. and Ort, D.R., 2014. Impacts of rising tropospheric ozone on photosynthesis and metabolite levels on field grown soybean. *Plant Sci.* 226, 147–161.
- Swedish EPA, 2019. Underlag till regeringens klimatpolitiska handlingsplan - Redovisning av Naturvårdsverkets regeringsuppdrag (in Swedish). Rapport 6879, ISBN 978-91-620-6879-0, ISSN 0282-7298.
- Tarvainen, V., Hakola, H., Hellén, H., Bäck, J., Hari, P. and Kulmala, M., 2005. Temperature and light dependence of the VOC emissions of Scots pine. *Atmos. Chem. Phys.* 5, 989–998.
- Tarvainen, V., Hakola, H., Rinne, J., Hellén, H. and Haapanala, S., 2007. Towards a comprehensive emission inventory of terpenoids from boreal ecosystems. *Tellus*, 59B, 526–534.
- Taylor, G., Tallis, M.J., Giardina, C.P., Percy, K.E., Miglietta, F., Gupta, P.S., Gioli, B., Calfapietra, C., Gielen, B., Kubiske, M.E., Scarascia-Mugnozza, G.E., Kets, K., Long, S.P. and Karnosky, D.F., 2008. Future atmospheric CO₂ leads to delayed autumnal senescence. *Global Change Biol.*, 14, 264–275.
- Temple, P. and Taylor, O., 1983. World-wide ambient measurements of peroxyacetyl nitrate (PAN) and implications for plant injury. *Atmos. Environ.*, 17, 1583–1587.
- Therasme, O., Volk, T.A., Eisenbies, M.H., et al., 2021. Life cycle greenhouse gas emissions of ethanol produced via fermentation of sugars derived from shrub willow (*Salix* ssp.) hot water extraction in the Northeast United States. *Biotechnol. Biofuels*, 14, 52.
- Tingey, D.T., Manning, M., Grothaus, L.C. and Burns, W. F., 1980. Influence of light and temperature on monoterpene emissions from slash pine. *Plant Physiol.*, 65, 797–801.
- Toome, M., Randjärv, P., Copolovici, L., Niinemets, Ü., Heinsoo, K., Luik, A. and Noe, S.M., 2010. Leaf rust induced volatile organic compounds signalling in willow during the infection. *Planta*, 232, 235–243.
- Van Dingenen, R., et al., 2009. The global impact of ozone on agricultural crop yields under current and future air quality legislation. *Atmos. Environ.*, 43, 604–618.
- VanReken, T. M., Greenberg, J. P., Harley, P. C., Guenther, A. B. and Smith, J. N., 2006. Direct measurement of particle formation and growth from the oxidation of biogenic emissions. *Atmos. Chem. Phys.*, 6, 4403–4413
- Vickers, C.E., Gershenzon, J., Lerdau, M.T. and Loreto, F., 2009. A unified mechanism of action for volatile isoprenoids in plant abiotic stress. *Nat. Chem. Biol.*, 5, 283–291.

- Vyskocil, A., Viau, C. and Lamy, S., 1998. Peroxyacetyl nitrate: Review of toxicity. *Hum. Exp. Toxicol.*, 17, 212–220.
- Wagg, S., Mills, G., Hayes, F., Wilkinson, S., Cooper, D. and Davies, W.J., 2012. Reduced soil water availability did not protect two competing grassland species from the negative effects of increasing background ozone. *Environ. Pollut.*, 165, 91–99.
- Walling L.L., 2000. The myriad plant responses to herbivores. *J. Plant Growth Regul.*, 19, 195–216.
- Wang, K.-Y. and Shallcross, D.E., 2000. Modelling terrestrial biogenic isoprene fluxes and their potential impact on global chemical species using a coupled LSM–CTM model. *Atmos. Environ.*, 34, 2909–2925.
- Wang, M., 2018. Characteristics of BVOC emissions from a Swedish boreal forest: Using chambers to capture biogenic volatile organic compounds (BVOCs) from trees and forest floor. Thesis, Department of Physical Geography and Ecosystemscience, Lund University.
- Wang, M., Schurgers, G., Arneth, A., Ekberg, A. and Holst, T., 2017. Seasonal variation in biogenic volatile organic compound (BVOC) emissions from Norway spruce in a Swedish boreal forest. *Boreal Environ. Res.*, 22, 353–367.
- Watkins, E., Gianfagna, T.J., Sun, R. and Meyer, W.A., 2006. Volatile compounds of tufted hairgrass. *Crop Sci.*, 46, 2575–2580.
- Watson, L.A., Wang, K.-Y., Paul, H. and Shallcross, D.E., 2006. The potential impact of biogenic emissions of isoprene on urban chemistry in the United Kingdom. *Atmos. Sci. Lett.*, 7, 96–100.
- Went, F.W., 1960. Blue hazes in the atmosphere. *Nature*, 187, 641–643.
- Wiedensohler, A., Birmili, W., Nowak, A., Sonntag, A., Weinhold, K., Merkel, M., Wehner, B., Tuch, T., Pfeifer, S., Fiebig, M., et al., 2012. Mobility particle size spectrometers: Harmonization of technical standards and data structure to facilitate high quality long-term observations of atmospheric particle number size distributions. *Atmos. Meas. Tech.*, 5, 657–685.
- Wildt, J., Kobel, K., Schuh-Thomas, G., et al., 2003. Emissions of Oxygenated Volatile Organic Compounds from Plants Part II: Emissions of Saturated Aldehydes. *J. Atmos. Chem.*, 45, 173–196.
- Williams, J. and Koppmann, R., 2007. Introduction. In: Koppmann, R. (ed.), *Volatile Organic Compounds in the Atmosphere*, Blackwell Publishing Ltd, Oxford, UK, ISBN: 978-1-4051-3115-5, 1–32.
- Winer, A.M., Arey, J., Atkinson, R., Aschmann, S.M., Long, W.D., Morrison, C.L. and Olszyk, D.M., 1992. Emission rates of organics from vegetation in California's central valley. *Atmos. Environ.*, 26A, 2647–2659.
- Wittig, V.E., Ainsworth, E.A., Naidu, S.L., Karnoski, D.F. and Long, S.P., 2009. Quantifying the impact of current and future tropospheric ozone on tree biomass, growth, physiology and biochemistry: a quantitative meta-analysis. *Global Change Biol.*, 15, 396–424.
- Xie, X., Kirby, J. and Keasling, J.D., 2012. Functional characterization of four sesquiterpene synthases from *Ricinus communis* (castor bean). *Phytochemistry*, 78, 20–28.

- Yuan, J.S., Himanen, S.J., Holopainen, J.K., Chen, F. and Stewart Jr., C.N., 2009. Smelling global climate change: mitigation of function for plant volatile organic compounds. *Trends Ecol. Evol.*, 24, 323–331.
- Zenone, T., Zona, D., Gelfand, I., Gielen, B., Camino-Serrano, M. and Ceulemans, R., 2016. CO₂ uptake is offset by CH₄ and N₂O emissions in a poplar short-rotation coppice. *GCB Bioenergy*, 8, 524–538.
- Zhang, S.H., Shaw, M., Seinfeld, J.H. and Flagan, R.C., 1992. Photochemical aerosol formation from alpha-pinene and beta-pinene. *J. Geophys. Res.*, 97, 20717–20729.
- Åhman, I. and Larsson, S., 1999. Breeding for resistance in willow for energy production (in Swedish). *Växtnotiser*, 63, 17–19.

Web references

- Paris Agreement, 2015 <https://unfccc.int/process-and-meetings/the-paris-agreement/the-paris-agreement> (last accessed 2021-07-20)
- Lantmäteriet (<https://minkarta.lantmateriet.se/> (accessed 2021-03-30)).

