



LUND UNIVERSITY

Experimental and numerical investigation on the shear strength of glulam

Crocetti, Roberto; Gustafsson, Per-Johan; Danielsson, Henrik; Emilsson, Arne; Ormarsson, Sigurdur

Published in:

Proceedings of International Council for Research and Innovation in Building and Construction, Working Commission W18 - Timber Structures, CIB-W18

2010

Document Version:

Publisher's PDF, also known as Version of record

[Link to publication](#)

Citation for published version (APA):

Crocetti, R., Gustafsson, P.-J., Danielsson, H., Emilsson, A., & Ormarsson, S. (2010). Experimental and numerical investigation on the shear strength of glulam. In R. Görlacher (Ed.), *Proceedings of International Council for Research and Innovation in Building and Construction, Working Commission W18 - Timber Structures, CIB-W18* Article CIB-W18/43-12-2 (CIB-W18 Meeting). Lehrstuhl für Ingenieurholzbau und Baukonstruktion, Universität Karlsruhe.

Total number of authors:

5

General rights

Unless other specific re-use rights are stated the following general rights apply:

Copyright and moral rights for the publications made accessible in the public portal are retained by the authors and/or other copyright owners and it is a condition of accessing publications that users recognise and abide by the legal requirements associated with these rights.

- Users may download and print one copy of any publication from the public portal for the purpose of private study or research.
- You may not further distribute the material or use it for any profit-making activity or commercial gain
- You may freely distribute the URL identifying the publication in the public portal

Read more about Creative commons licenses: <https://creativecommons.org/licenses/>

Take down policy

If you believe that this document breaches copyright please contact us providing details, and we will remove access to the work immediately and investigate your claim.

LUND UNIVERSITY

PO Box 117
221 00 Lund
+46 46-222 00 00

Experimental and numerical investigation on the shear strength of glulam

Roberto Crocetti¹, Per Johan Gustafsson², Henrik Danielsson², Arne Emilsson³, Sigurdur Ormarsson⁴

¹Division of Structural Engineering, Lund University, Sweden

²Division of Structural Mechanics, Lund University, Sweden

³Limträtenik AB, Falun, Sweden

⁴Department of Civil Engineering, DTU, Denmark

1 Introduction

According to EC5, the shear resistance of a structural timber element should be determined on the basis of the characteristic shear strength of the material, along with classical beam theory. For glulam, the characteristic strength values are given by the European standard EN 1194 [3], which assumes a direct relationship between tensile strength and shear strength of the lamination

$$f_{v,k} = 0.32 \cdot (f_{t,0,k})^{0.8}$$

As an example, the characteristic shear strength of glulam class GL28c, consisting of inner laminations with characteristic tensile strength $f_{t,0,k} = 14.5$ MPa, would be $f_{v,k} = 0.32 \cdot (14.5)^{0.8} = 2.9$ MPa.

However, recent investigations both on glulam members [4] and on timber members [5] have shown that the shear strength of spruce is higher than the shear strength obtained by means of the model proposed by EN1194. Moreover, the studies show that the shear strength is nearly constant, regardless the strength class of the timber material.

1.1 Objective

The general objective of this study is to gain a better knowledge on the shear strength of glulam subjected to predominant shear loading and with different boundary conditions. Specific objectives include the following:

- Propose a practical setup for testing glulam in shear which does not generate too large secondary stresses in the specimen, e.g. perpendicular to the grain stresses.
- Investigate the shear strength of glulam specimens both with I-cross section and with rectangular cross section.
- Investigate the influence of growth ring orientation on the shear strength of glulam

1.2 Background

The European standard EN 408 [6] gives indications for the determination of shear strength of timber. The loading arrangement according to EN 408 involves gluing of steel plates to the timber specimens. This method is rather unpractical and it often leads to failure in the glued area at the interface between the steel plate and the timber specimen, due to high perpendicular-to-grain stresses in the vicinity of the point of application of the load, resulting in invalid shear strength values [5]. There are also indications that the shear strength obtained by testing according to EN 408 is lower than the shear strength obtained by means of ordinary beam test methods [10].

Several authors have investigated on the shear strength of timber.

H. Granholm [7] conducted shear tests on I-beams in four-point bending. Totally 19 beams were tested, divided in four main groups. The first three groups consisted of I-beams with nominally identical flanges with cross section $152 \times 25 \text{ mm}^2$. The results showed that I-

beams with webs consisting of boards placed edgewise (i.e. primarily subjected to shear in radial plane) had considerably greater strength than the I-beams with webs consisting of boards flatwise placed (i.e. primarily subjected to shear in tangential plane). In particular, the I-beams with webs consisting of three edgewise placed boards, showed shear strength values about 70% larger than the shear strength of I-beams with webs consisting of flatwise glued boards.

J.K.Denzler et al. [5] presented the results of 382 shear tests carried out according to EN 408, with specimen size 32 x 55 x 300 mm³. The main results of this research are: *i)* mean shear strength is significantly lower when failure occurs in tangential direction as compared to shear failure in radial direction across the growth rings (radial direction); *ii)* knots do not have remarkable influence on shear strength; *iii)* correlation between density and shear strength; *iv)* no evidence of an increase of characteristic shear strength for higher strength classes.

B. Madsen [8] conducted shear tests on hundreds of timber specimens. The specimens were boards with realistic dimensions (cross section 35x140 mm², and different lengths up to 560 mm). The specimens were loaded by a direct application of a moment couple created by two parallel forces applied to the edge of the specimens. The main results obtained by the author are: *i)* the stressed volume has influence on the shear strength; *ii)* shear strength strongly decreases with increasing moisture content; *iii)* shear strength of specimens loaded in tangential direction is similar to shear strength of specimens loaded in radial direction across the growth rings.

D.R.Rammer [9] investigated the behaviour of glulam beams with rectangular cross section tested in a five-point beam configuration to determine the shear strength capacity. A total of 200 specimens were tested, 100 loaded edgewise about the strong axis (shear in the radialplane) and 100 loaded flatwise about the weak axis (shear in the tangential plane). The specimens had all the same width but different depths, in order to investigate the influence of volume on the shear strength. The main findings obtained by this research are: *i)* shear strength decreases with increasing specimen volume; *ii)* flatwise loaded specimens showed higher shear strength than edgewise loaded specimens, due to “system effect”.

M. Poussa et al. [10] performed some 280 shear tests, of which 200 were performed according to the European standard EN-408, and 80 on beams with I-cross section loaded in a three-point beam configuration. The main result of this research is that the shear strength of beam specimens was about two times that of shear specimens.

K. B. Dahl [11] investigated the shear behaviour of some 83 small scale specimens loaded in different planes: The authors used the so called “Arcan specimen” for their investigations. Such a specimen is butterfly shaped and has the peculiarity of generating a shear distribution that is nearly uniform over the critical cross section. The authors found that the shear strength of specimens loaded in the tangential plane was about 50% higher than the shear strength of specimens loaded in the radial plane.

G. Schickhofer et al [4] conducted tests on glulam beams with I-cross section loaded in a three-point beam configuration to determine the shear strength capacity. Totally, 24 specimens were tested. Different glulam classes, from GL24 to GL36 were used for the manufacture of the specimens. The main findings are: *i)* no clear evidence of relationship between glulam strength class and shear strength; *ii)* a number of failure occurred due to high perpendicular to grain compression between web and flange at the support.

Sundström et al [12] conducted shear tests on 104 glulam beam in a three-point beam configuration to determine the shear strength under varying humidity conditions. The main finding of this research is that variation of humidity does not considerably affect the shear strength of glulam.

2 Test methods and material

Two kinds of specimens were used in the present shear strength tests: specimens similar to those defined in EN408 (here denoted “modified EN408 tests”) and beams. The test setup and test results are in greater detail presented in [1] and [2], respectively. All tests were made as short time ramp loading tests with time to failure in the order of 5 minutes.

The tested specimens were made of glulam “L40”. The raw material used for the laminations was Norway spruce, with characteristic tensile strength $T \geq 22$ MPa and with nominal thickness $t=45$ mm. The mean density and moisture content was 471 kg/m^3 and 11.1%, respectively, for the material used in EN408-test, and 464 kg/m^3 and 10.7%, respectively, for the material in tested beams. The EN408 specimens were conditioned at 60% RH and the beams indoors under plastic cover. The specimens were randomly cut from different beams.

2.2 Modified EN408 test method and test specimens

The test setup and specimen geometry of the modified EN408 tests are shown in Figure 1. These tests comprised 9 test series with 4 nominally equal tests in each series. The test specimen is attached to the two steel parts by a large number of screws, not by glue as proposed in the EN-standard. The use of screws was mainly due to practical reasons. However, the use of screws - instead of glue - may also contribute to a more uniform distribution of the shear load. The use of knee-shaped steel parts, instead of use of straight steel plates and inclined application of the load is partly due to practical reasons and partly to avoid compressive load across the fracture section. The specimens were moreover given a 115 mm long centric cut of width 3 mm in each end. It is believed that this cut is important for the test results. Initial tests of specimens without the cut showed fracture at low load due to significant tensile stress perpendicular to grain at two of the corners of the specimen. Fracture did not develop as a shear failure along the centre line of the specimen, but instead as a combined tensile and shear failure starting in the vicinity of a corner. This experimental observation was verified by finite element stress analysis, showing significant perpendicular to grain tensile stresses in the corner regions. Along the centerline of the specimen is, on the contrary, a stress state with almost pure shear stress due to symmetry. A drawback of the end-cuts could be that they may give shear stress concentration and a more non-uniform shear stress distribution. This is analyzed by non-linear finite element analysis in a following section.

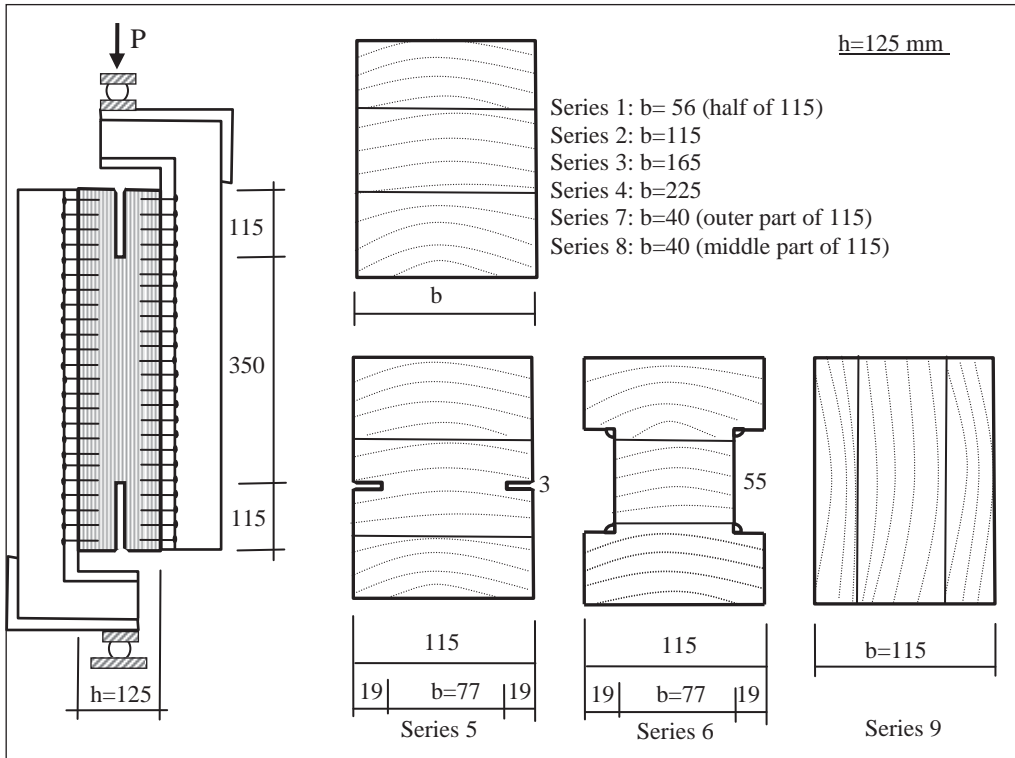

Figure 1. Shear tests by modified EN408 test method: setup and specimens for 9 test series

2.3 Beam test method and test specimens

The beam tests comprised 6 test series with 4 nominally equal tests in each series. Series 1 related to a rectangular beam cross section and series 2-6 to various support and loading conditions for beams with an I-shaped cross section, manufactured by cutting of beams with a rectangular section. Cross sections and loading conditions are shown in Figure 2 and 3. The length of the decisive shear span was in all tests 787 mm, i.e. 2.5 times the beam height, 315 mm. Series 3 related to possible influence of an overhang at support. Series 4 and 5 related to possible influence of increased and decreased perpendicular to grain compressive stress in the wood in the vicinity of the support. The additional compressive and tensile loads were created by a steel beam loading arrangement. The tensile load was applied to the upper surface of the beam by means of a number of screws. Series 6 related to the shear strength of a continuous beam where the bending moment is large at the support. The beam in series 6 is statically indeterminate and the ratio between the recorded load P and the shear force V was calculated by conventional beam theory, giving $V=0.815 P$. Consideration to shear deformation by Timoshenko beam theory would indicate a slightly lower shear force at given recorded load, $V=0.794 P$.

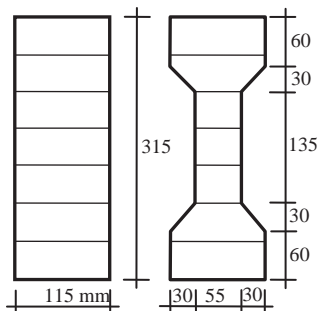

Figure 2 (left). Cross sections of tested beams

Section data:

Section	A, mm^2	I, mm^4	$S_{h/2}, \text{mm}^3$
Rectangular	36225	$299.5 \cdot 10^6$	$1.426 \cdot 10^6$
I-shape	26325	$276.3 \cdot 10^6$	$1.220 \cdot 10^6$

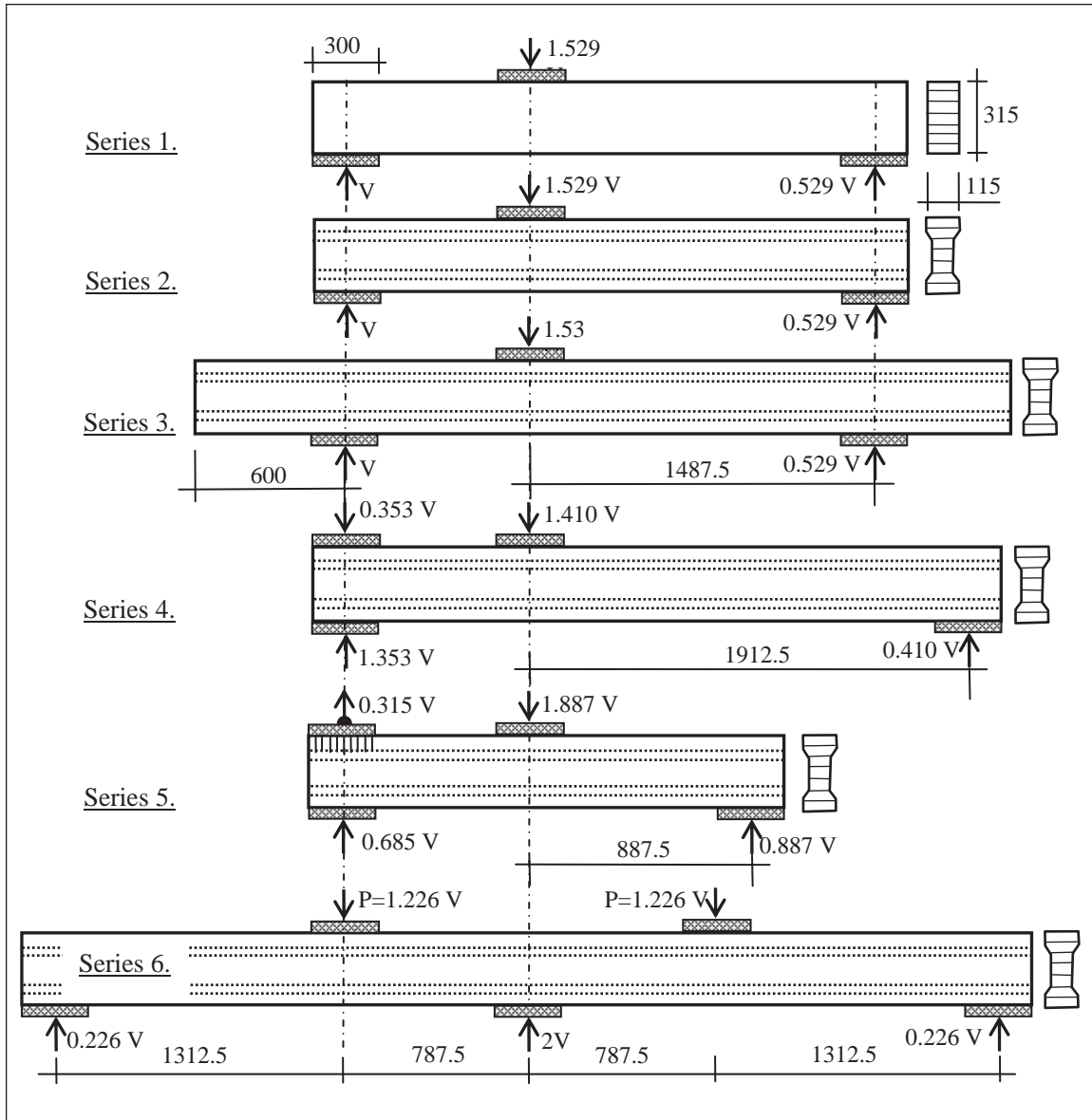

Figure 3. Beam tests

3 Test results

3.1 Modified EN408 test results

Table 1 shows the test results for the modified EN408 tests. The size of the fracture section is denoted A , i.e. $A=350 \times 77 \text{ mm}^2$ for series 5 and 6, and $350 \times 115 \text{ mm}^2$ for the other series. This means that the indicated strength value, P_f/A , is the mean shear stress at failure. Also density and annual ring thickness was measured for the individual specimens, giving average results as indicated in the table. The results show no consistent influence of glulam width and no significant difference between rectangular and I-shaped cross sections. The specimens with a slit similar to a drying crack showed about 10% increase in shear strength. Comparison between series 2 and 9 shows that flatwise loading with standing orientation of the annual rings in shear section gives about 15% decrease in shear strength. Series 2, 7 and 8 shows that sawing of a wide section into thinner sections can reduce the strength by about 10%, but no difference between the middle part and the edge parts was found. Correlation between density and strength was found. Out of the 32 specimens tested, it was found that the two specimens with lowest strength were the two specimens with lowest density. Figure

4 shows strength versus density. Linear regression analysis for all tests considered as one group gave the upper line shown in the figure, which is: $f_v = 0.17 + 0.0102\rho$

where $f_v = P_f/A$ is the shear strength in MPa and ρ the density in kg/m^3 at 11% MC. No correlation between strength and annual ring thickness was found. Mean strength and standard deviation for all 32 specimens were 4.96 MPa and 0.73 MPa, respectively, which gives a coefficient of variation $\text{CoV} = 0.73/4.96 = 15\%$. At the assumption of normal distribution, this gives an estimated 5% fractile characteristic strength $f_{v,k} = 4.96 - 1.64 \cdot 0.73 = 3.76$ MPa.

Table 1. Modified EN408 shear strength test results, density ρ and annual ring width t_a

Test series	Cross section width, mm	Individual test results				Mean results				
		P_f/A , MPa				P_f/A	Std	CoV	ρ , kg/m^3	t_a , mm
1	56	5.05	-	-	-	5.05	-	-	496	1.0
2	115	5.56	5.47	5.79	3.60	5.11	1.01	20%	461	2.7
3	165	5.32	6.23	5.35	5.49	5.60	0.43	8%	477	3.0
4	215	4.94	4.19	5.16	5.25	4.89	0.48	10%	459	2.5
5	77 (115), slit	6.23	6.12	4.53	5.49	5.59	0.78	14%	474	3.0
6	77 (115), I	5.60	4.56	4.82	5.23	5.05	0.46	9%	468	2.3
7	40	4.22	5.38	3.83	-	4.48	0.81	18%	478	2.3
8	40	4.91	4.60	4.09	4.19	4.45	0.38	9%	481	2.0
9	115,	4.15	4.70	3.45	5.07	4.34	0.70	16%	463	2.7
Overall average						4.96	0.63	13%	471	2.5

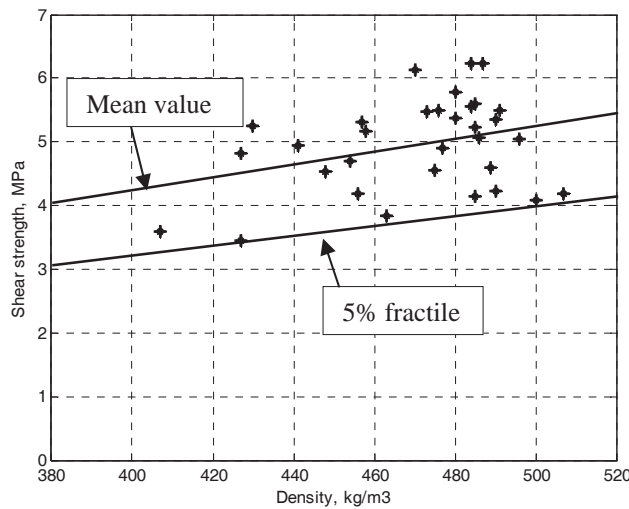

Figure 4. Shear strength, P_f/A , versus density from modified EN408 test results

3.2 Beam test results

The beam shear strength test results are shown in Table 2. The shear strength f_v was calculated according to conventional beam theory from the recorded failure value of the shear force, V_f . Also the compressive stress σ_c perpendicular to grain at the supports is calculated according to conventional Bernoulli-Euler beam theory. All beams failed in a sudden manner and most of them due to sudden development of a shear crack along the beam. Some of the beams did, however, fail in bending or in a combination of shear and bending. These beams are indicated with * in Table 2. For these cases the true shear strength would be equal to or greater than the recorded shear stress at failure. These perhaps somewhat too low recorded shear failure stresses were not excluded when calculating mean strengths and standard deviations. Series 1 and 2 show significantly higher strength for the

I-shaped cross sections than for the rectangular cross section. From series 3 it seems that increased beam length at support has no or only some small beneficial influence. Comparison between series 2, 4 and 5 suggest that increased compressive stress perpendicular to grain may give a slight increase of the shear strength. Comparison between series 2 and 6 suggests that the shear force capacity at an inner support of a continuous beam is greater than shear capacity of a support at the end of a beam. Taking the test results of series 2, 3, 4 and 5 as one group, the mean strength is 6.27 MPa and the estimated 5% fractile characteristic strength $6.76-1.64\cdot0.76=5.51$ MPa. The corresponding figures for the rectangular beams, series 1, are 4.57 MPa and $4.57-1.64\cdot0.41=3.90$ MPa, respectively. For the continuous beams, series 6, the corresponding figures are 7.22 MPa and $7.22-1.64\cdot0.44=6.50$ MPa.

Table 2. Beam shear strength test results

Test series	Test series characteristic	Individual test results				Mean shear strength			Mean σ_c , MPa
		f_v , MPa				f_v	std	cov	
1	Rectan.	4.24 *	4.22 *	4.77	5.06	4.57	0.41	9.0%	1.60
2	I-section	5.86	6.43 *	6.63	5.31	6.06	0.60	9.9%	2.28
3	Overhang	5.42	6.84 *	4.78 *	7.78	6.21	1.36	21.9%	2.33
4	Compression	6.71 *	6.32	6.41	7.06	6.63	0.33	5.0%	4.25
5	Tension	6.30	-	6.57	5.66	6.18	0.47	7.6%	0.87
6	Cont. beam	7.59	6.58	7.37	7.34 *	7.22	0.44	5.4%	5.42
Overall average						6.14	0.58	9.4%	2.78

* bending failure or combined bending and shear failure

4 Stress and strength analysis

4.1 Stress and strength analysis of modified EN408 specimen

Two dimensional plane stress linear elastic finite element analysis of the modified EN408 test setup in Figure 1 was performed, with glulam specimen geometry according to series 2. Both the glulam specimen and the knee-shaped steel parts were included in the model, however ignoring the compliance of the screw connection and instead assigning full interaction between the glulam and steel parts. Stress components $\sigma_{||}$, σ_{\perp} and τ in the glulam specimen are illustrated in Figure 5, for specimens with and without centric end-cuts. Applied external load corresponds to a mean shear stress of 5.0 MPa in the fracture sections. The results are based on material stiffness parameters $E_{||}=13\ 700$ MPa, $E_{\perp}=460$ MPa, $G_{||\perp}=850$ MPa, $\nu_{||\perp}=0.46$ for glulam and $E=210\ 000$ MPa, $\nu=0.3$ for steel parts. As indicated by preliminary tests of specimen without the end-cuts, the modified EN408 test setup results in significant perpendicular to grain tensile stress σ_{\perp} in two corner regions of the specimen. This stress is reduced by introducing the cuts, but instead stress concentrations arise at the ends of the cuts.

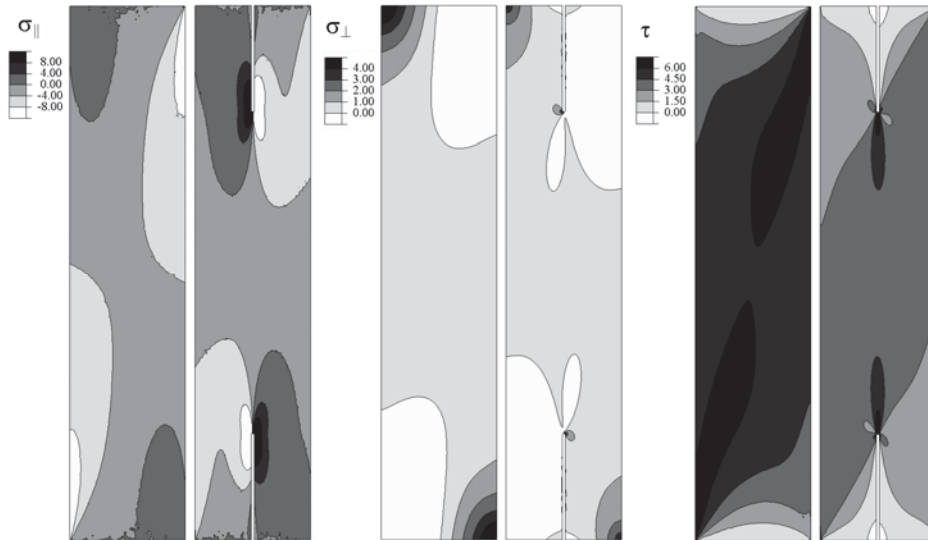

Figure 5. Stress $\sigma_{||}$, σ_{\perp} and τ for modified EN408 specimen with and without end-cuts

Nonlinear fracture course analysis of the specimen with centric end-cuts was also performed using cohesive spring elements in the fracture section with a piecewise linear shear stress-displacement relationship to represent the strain softening properties. The initial stiffness was adjusted to represent linear elastic behaviour up to maximum stress, i.e. local material strength. For increasing displacement, the ability to transfer stress diminishes and the (negative) stiffness is adjusted to represent the fracture energy of the material. Nonlinear stress-strain performance outside the fracture process region contributes however to a more uniform shear stress distribution. The volume of material exposed to the high local stress is furthermore very small: only about 1% of the volume has reached shear stress greater than 95% of the local material strength at maximum load P_f/A . This means that the test results P_f/A may be a reasonably relevant measure of for the actual specimen volume. The mean stress in the fracture area at maximum load P_f/A was by the nonlinear fracture course analysis found to be 60-70% of the local material strength for fracture energies in the range 0.600-1.200 Nmm/mm².

4.2 3D stress analysis of beams

To study how shear stresses vary over cross-sections of the studied glulam beams three dimensional finite element simulations were performed. To illustrate how the simulation results can be presented, Fig. 6 shows deformed geometry of the beams, mesh pattern, load distribution (corresponds to 147.7 kN), boundary conditions, annual ring pattern, colour plots and path plots for the global shear stress τ_{yz} . The wood material is assumed to be an orthotropic material with stiffness parameters: $E_r = 800$, $E_t = 500$, $E_l = 14000$, $G_{rt} = 60$, $G_{rl} = 600$, $G_{tl} = 700$, $\nu_{rl} = 0.02$, $\nu_{tl} = 0.02$, $\nu_{tr} = 0.3$. The pith is assumed to be a straight line along the centre of the bottom surface of each wood member. The interaction between the steel plates and the wood material is modelled as a full contact interaction based on penalty formulation.

The simulation results show clearly how the global shear stress τ_{yz} varies over the cross sections. For the rectangular beam the largest shear stresses occur at the neutral axis, close to the side surfaces whereas for the I-beam they occur in the inner corners where the web and the flange are connected. These results have been compared with hand calculations. The maximum shear stresses became 5% and 9% larger than the hand calculated values for the rectangular respective I-beams. The main reason for this discrepancy is that the simulation takes into account the curved annual rings and it generates stress concentrations in the inner corners of the I-beams.

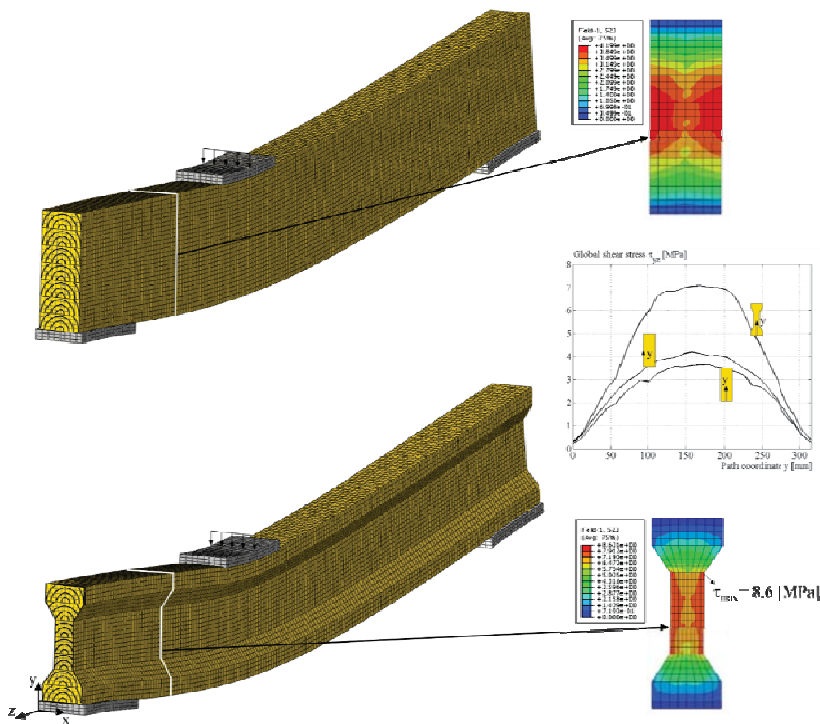

Figure 6. Illustration of bending deformations and related shear stress distribution over a critical cross section (all deformations are magnified 8 times).

5 Discussion and conclusions

The proposed test method, i.e. the modified EN 408 with two 115 mm cuts at the bottom part and at the upper part has the advantage, that it allows for a state of stress in the region between the cut tips characterized by predominant longitudinal shear (i.e. shear parallel to the grain). Moreover, the presence of the cuts significantly reduces the tension perpendicular to grain at the corners of the specimen. The disadvantage of such a test method could be the high stress concentration that occurs at the cut tips, which may *negatively* influence the shear strength of the timber. On the other hand, the cuts “oblige” the failure surface to occur at a given plane, which may *positively* influence the shear strength of timber. Specimens with width between 40 mm and 215 mm were shear tested according to modified EN 408. Similar shear strengths were achieved for all these specimens, indicating that the width of the specimen does not have a remarkable influence on shear strength.

In general it can be stated that testing according to modified EN 408 gives shear strength lower than shear strength obtained by beam testing. However, if the beam specimens with applied compression at the top of the support and the beam specimens on three supports were excluded, the characteristic shear strengths obtained by the two methods would become comparable.

For the modified EN 408 tests, no remarkable shear strength differences between specimens with rectangular cross section and specimens with I-cross section could be observed. On the other hand higher shear strength could be observed for beams with I-cross section than for beams with rectangular cross section. The reason for such a discrepancy could be the possible beneficial influence of higher perpendicular to grain compression in the web of the I-beams. Moreover, it should be observed that 50% of the beam specimens with rectangular cross section failed in bending. Perhaps, if bending failure had been prevented, shear

strength similar to that for I-beams could have been achieved also for beams with rectangular cross section.

Four specimens were tested according to modified EN 408 method, loading in the radial direction instead of loading in the tangential direction – as occurred in all other cases. It was observed that the shear strength in the radial direction was slightly lower than the shear strength for specimens loaded in the tangential direction. This is in line with the results by Dahl et al, but not with the results obtained by all the other authors cited in this paper. However, the number of specimens loaded in the radial direction is too low for drawing any relevant conclusions.

Overhangs do not seem to have any evident effect on the shear strength for the tested timber beams. Neither, has the action of an external tension applied on the upper part of the beam at the support, in the direction perpendicular to grain. On the other hand, external perpendicular to grain compression stress applied on the upper part of the beam at the support seem to affect the shear strength positively. However, this conclusion cannot be extended to cases where the applied external tension or compression are higher than those used for these experiments.

In the case of beam with three supports higher shear strength than the shear strength for simply supported beams was observed. This may be due to the fact that at the intermediate support the transmission of internal forces occurs in a great extent by “strut action” and the zones with pure shear action are rather small.

Acknowledgments

The authors gratefully acknowledge the financial support of the Swedish Glulam Association.

References

- [1] Gustafsson, P.J., Emilsson, E., Crocetti, R. and Ormarsson, S.: ”Provningar av limträskjuvhållfasthet hösten 2009”, Report TVSM-7158, Div. of Struct. Mech., Lund University, Sweden, 2009
- [2] Andersson, D. and Odén, J.: “Träs skjuvhållfasthet och limträbalkars tvärkraftskapacitet – provningar och beräkningar”, Master’s Dissertation, Report TVSM-5159, Div. of Struct. Mech., Lund University, Sweden, 2009
- [3] EN 1194:1999, “Glued laminated timber – Strength classes and determination of characteristic values”, 1999
- [4] Schinkhofer, G and Obermayr, B.: “Development of an optimized test configuration to determine shear strength of glued laminated timber”, ,CIB-W18/31-21-1
- [5] Denzler, J. K. and Glos, P.: “Determination of shear strength values according to EN 408”, Material and Structures, 2007
- [6] prEN 408:2003 “Timber Structures – Structural Timber and Glued Laminated Timber – Determination of Some Physical and Mechanical Properties”, 2003
- [7] Granholm, H. “Armerat trä”. Transactions of Chalmers University of Technology, Göteborg, 1954
- [8] Madsen, B. “Structural Behaviour of Timber”. Amer Society of Civil Engineers ISBN -10: 0969616201, 1995
- [9] Rammer, D.: “Shear strength of glued-laminated timber beams and panels”. Madison, Forest Products Laboratory, USDA Forest Service. 1996
- [10] Poussa M., Tukiainen P.: “Experimental Study of Compression and Shear Strength of Spruce Timber”, CIB- W18/40-6-2, Bled, Slovenia, 2007
- [11] Dahl, K. “Mechanical properties of clear wood from Norway spruce”. Department of Structural Engineering, Norwegian University of Science and Technology. ISBN 978-82-471-1911-2, 2009
- [12] Sundström, T. Kevarinmäki, A. Toratti, T.: “ Shear strength of Glulam beams under varying humidity conditions, WCTE 2010, Riva del Garda, Italy, 2010